

SNAPPER®

21" STEEL DECK WALK BEHIND

SERIES 0 & 1

MODELS

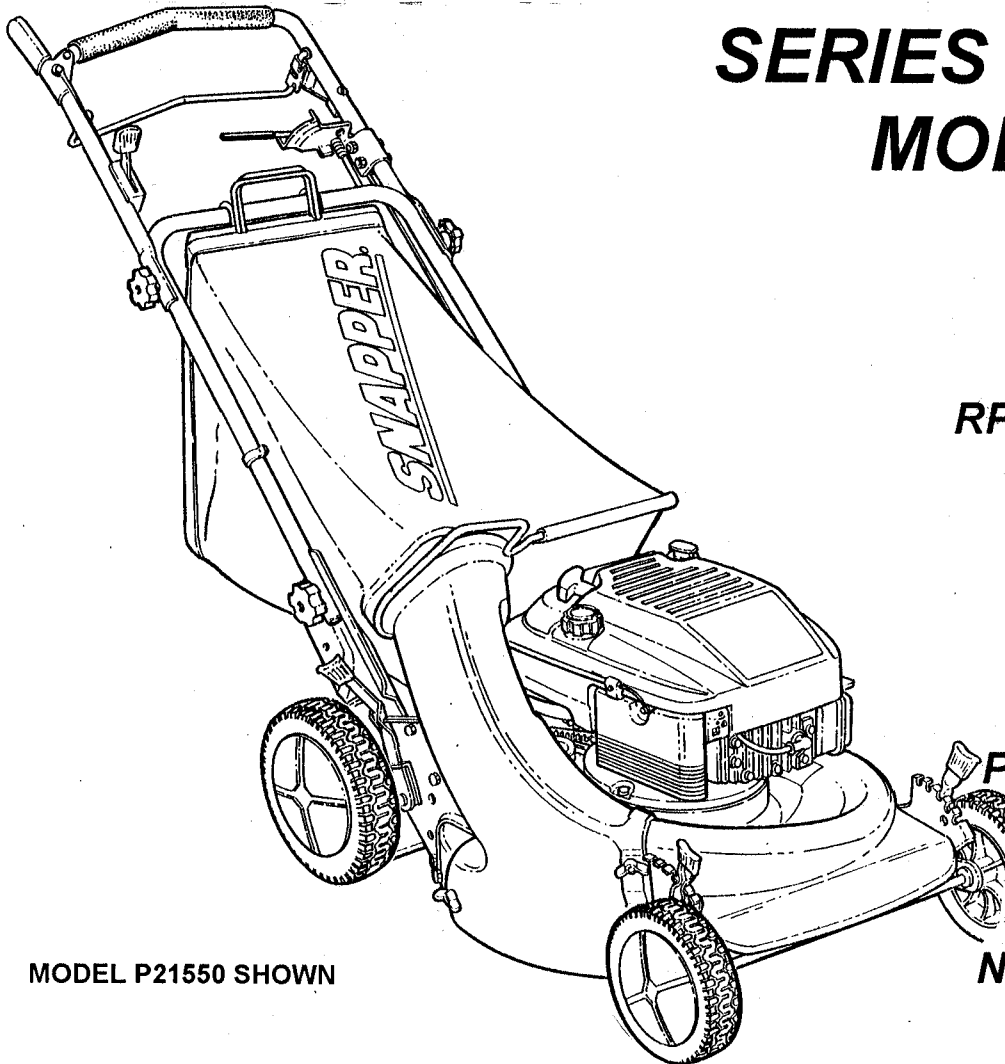

MODEL P21550 SHOWN

- 21500
- R21500
- P21550
- RP21550
- RP21550T2
- EP21450
- EP21550
- D21500
- DP21500
- RP21600
- EP21600
- P21600TV
- R21501
- RP21501
- NR21501
- NRP21501

MODEL NUMBER EXPLANATION

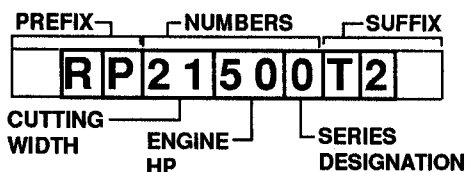

PREFIX EXPLANATION

R-Recycling Mower
 P-Self-Propelled Mower
 C-Commercial Mower
 E-European Market Mower
 D-Side Discharge Mower
 N-California Only

NUMBERS EXPLANATION

21-Cutting Width
 40-4hp Engine
 45-4-1/2hp Engine
 50-5hp Engine
 55-5-1/2hp Engine
 0-Series Designation
 1-Series Designation

SUFFIX EXPLANATION*

T-Tecumseh Engine
 R-Robin Engine
 KW-Kawasaki Engine
 E-Electric Start
 V-Overhead Valve Engine
 2-2-Cycle Engine

* No Suffix for models powered by Briggs & Stratton Engines

Thank you for buying a SNAPPER Product! Before operating your mower, read this manual carefully and pay particular attention to the "IMPORTANT SAFETY INSTRUCTIONS" on page 2. Remember that mowers and all power equipment can be dangerous if used improperly and keep in mind that safety requires careful use in accordance with the operating instructions and common sense!

SNAPPER® McDonough, GA., 30253 U.S.A.

IMPORTANT SAFETY INSTRUCTIONS

WARNING: This powerful machine is capable of amputating hands and feet and can throw objects that can cause injury and damage! Failure to comply with the following instructions may result in serious injury to the operator or other persons. The owner of the mower must understand these instructions and, furthermore, must allow only persons who understand these instructions to operate mower. Each person operating the mower must be of sound mind and body and must not be under the influence of any substance which might impair vision, dexterity, or judgment. If you have any questions pertaining to your mower which your dealer cannot answer to your satisfaction, call or write the Customer Service Department at SNAPPER, McDonough, Georgia, 30253. Phone: (770) 954-2500.

PROTECTION FOR CHILDREN

1. DO NOT allow children in area when mower is being operated.
2. DO NOT allow pre-teenage children to operate mower.
3. Allow only responsible teenagers or adults with mature judgment to operate mower and only under close supervision.
4. Keep the area clear of all persons, particularly small children, and pets.

PREPARATION

1. Never operate mower without proper guards, plates, safety switches, or other safety protective devices in place and properly connected. Inspect to determine that these safety devices are installed properly, are in good repair, and operate properly. If the condition or operation of these devices are questionable, they must be repaired or replaced before using the mower. Be thoroughly familiar with the controls and proper use of the equipment.
2. Thoroughly inspect the area where the mower is to be used and remove all stones, sticks, wire, bones and other foreign objects. Also note the location of holes, stumps, and other possible hazards.
3. DO NOT operate mower when barefoot or wearing open sandals. Always wear substantial footwear and long pants.
4. Fill fuel tank before starting engine. Use approved fuel container. DO NOT smoke near open fuel container. DO NOT fill fuel tank indoors or when engine is running. Allow engine to cool for at least ten minutes before refilling. Wipe off any spilled fuel before starting engine. DO NOT run engine indoors.
5. Make sure that the wheel drive clutch control is disengaged before starting engine.
6. Never attempt to make a cutting height adjustment while the engine is running.
7. When mowing over rough ground or in tall grass, mower must be set at highest cutting position.
8. Mow only in daylight or in good artificial light.
9. Never operate mower in wet grass. Always be sure of your footing; keep a firm hold on the handle and walk; never run!
10. DO NOT operate mower without the grass bag (and adapter), side chute, mulch cover or adapter plug in place.

OPERATION

1. DO NOT change engine governor settings or over speed engine.
2. DO NOT put hands or feet near or under rotating parts. Keep clear of discharge area while engine is running.
3. STOP engine when crossing gravel drives, walks, or roads, and under any conditions where thrown objects might be a hazard.
4. After striking a foreign object or if mower vibrates abnormally, STOP the engine, disconnect and secure spark plug wire. Inspect the mower for any damage and repair the damage.
5. STOP blade and engine whenever you leave the operating position behind the handle for any reason, including clearing grass, emptying grass bag and making any adjustments, repairs, or inspections.
6. Before cleaning, repairing or inspecting, make certain blade and all moving parts have STOPPED. Disconnect and secure spark plug wire away from plug to prevent accidental starting.
7. STOP engine and wait until the blade comes to complete STOP before removing grass bag and/or clearing grass.
8. Mow across slopes, never up-and-down. Exercise CAUTION when changing directions on slopes. DO NOT mow steep slopes or other areas where stability or traction is in doubt.

MAINTENANCE AND STORAGE

1. Keep all nuts, bolts, and screws tight to be sure mower is in safe operating condition.
2. Never store mower with fuel in tank inside of a building where fumes may reach an open flame or spark. Allow engine to cool before storing in any enclosure.
3. To reduce fire hazard, keep mower free of grass, leaves, spilled fuel or excessive grease.
4. Check grass bag assembly frequently for wear or deterioration. Replace with new bag if loose seams or tears are evident. Replace slider or bag adapter if broken or cracked.
5. Have your mower inspected and serviced each year by an authorized Snapper dealer. Determine if any additional devices are available which might upgrade the safety of your mower.
6. Factory specified Snapper replacement parts must be used to assure adequate protection against injury.

Section I - FAMILIARIZATION

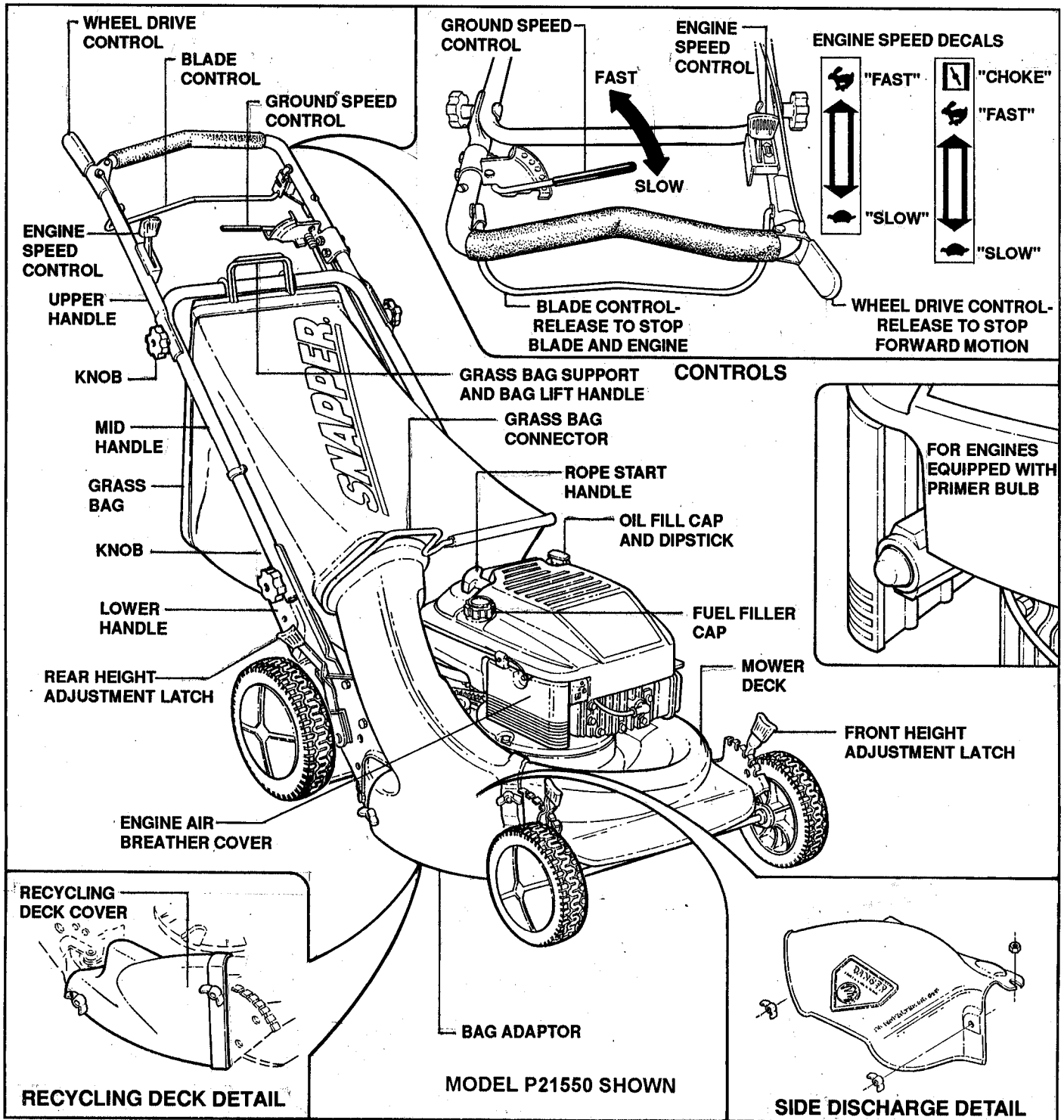

FIGURE 1.1

1.1 INTRODUCTION

This manual has been prepared for the operators of the SNAPPER Series 0 WALK BEHIND MOWERS. Its purpose, aside from recommending operating and routine service requirements, is to promote safety through the use of accepted operating practices. **Read, Understand and Follow** the "IMPORTANT SAFETY INSTRUCTIONS" on Page 2 of this manual and all safety messages on the mower and attachments before operating the mower.

1.2 NOMENCLATURE

The nomenclature drawing above, Figure 1.1, shows the essential parts of the SNAPPER Series 0 WALK BEHIND MOWERS. It is recommended that all operators of the mower become thoroughly familiar with the controls, parts and operation of the mower before operating. Specific details involving the engine are found in the separate engine owner's manual. Study these manuals before operating and keep both handy for future reference.

Section II - OPERATING INSTRUCTIONS

2.1 PRE-START CHECK LIST

Make the following checks and perform the service as required before each startup.

- A. Check guards, grass bag, bag adapter and deck cover for tightness. Make sure they are secure.
- B. Check engine oil and add oil as needed to bring level up to the full mark. Refer to Engine Manual for oil specifications.
- C. Check blade control to insure it works freely.
- D. Check cutting height. Adjust to desired height.
- E. Clean exterior surfaces of cutting deck and engine of any accumulation of dirt, grass, oil, etc. Keep engine air intake screen and cooling fins clear at all times.
- F. Add fuel to tank after pushing the mower outside where fumes can be safely dissipated. Make sure cap is tightened after refueling. Refer to Engine Manual for specifications. Use correct fuel to oil ratio as specified in Engine Manual for 2-cycle engines.

2.2 STARTING

A. ENGINE & BLADE

1. Move engine speed control lever to the "FAST" (⚡) or "CHOKE" (☒) position. Refer to Figure 2.1.

NOTE: Stop the engine (and blade) by releasing the blade control.

B. FORWARD MOTION OF MOWER

Stop forward motion of mower by releasing the wheel drive control. Refer to Figure 2.1.

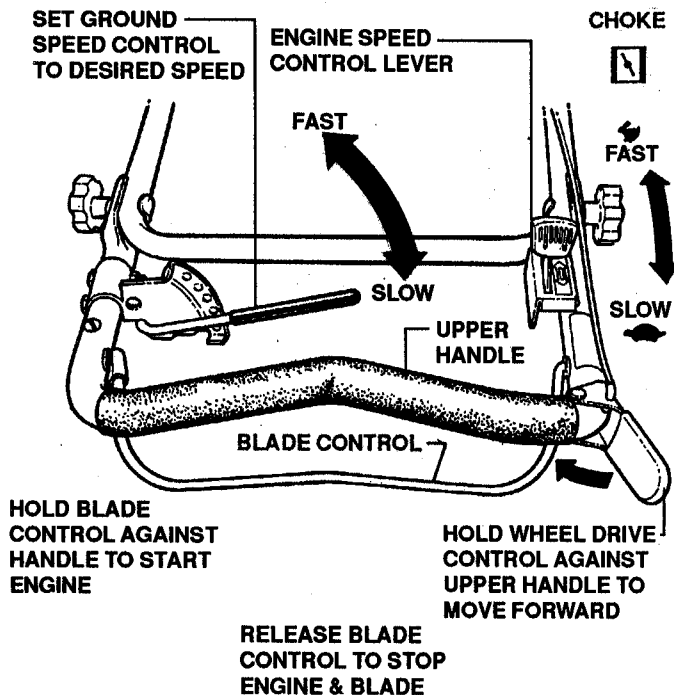

FIGURE 2.1

NOTE

If engine is equipped with a primer, move the engine speed control lever to "FAST" (⚡) position and push the primer button two times before starting a cold engine.

2. Hold blade control against upper handle.
3. Place left foot on top of left tire to steady mower.
4. Bend at waist to reach rope start handle. See Figure 2.2.

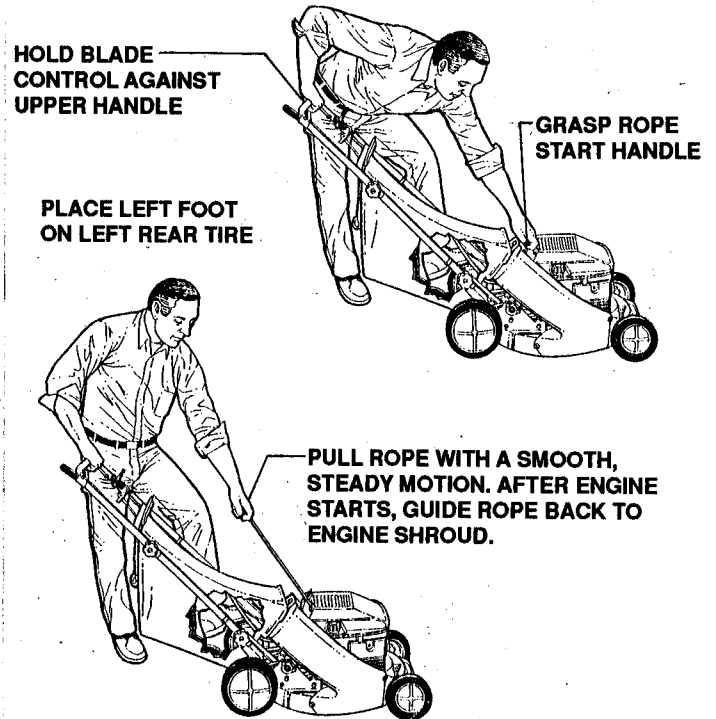

FIGURE 2.2

5. Pull rope start handle until engine starts. Guide rope slowly back into engine shroud to prevent rope or shroud breakage.
6. Move engine speed control lever to desired position.

NOTE

If engine is equipped with a choke, allow the engine to warm up before moving the engine speed control lever to desired position.

B. FORWARD MOTION OF MOWER

1. Move the ground speed control lever to the desired position. Refer to Figure 2.1.
2. Hold the wheel drive control against the upper handle to start forward motion of mower. Forward speed can be adjusted while the mower is moving by changing position of the ground speed control lever.

2.3 STOPPING

- A. Stop engine and blade by releasing the blade control. See Figure 2.1.

Section II - OPERATING INSTRUCTIONS

2.5 HANDLE HEIGHT ADJUSTMENT

The height of the upper mower handle can be adjusted for the operator's comfort as follows:

1. Loosen the lower nuts on each lower handle as shown in Figure 2.3.

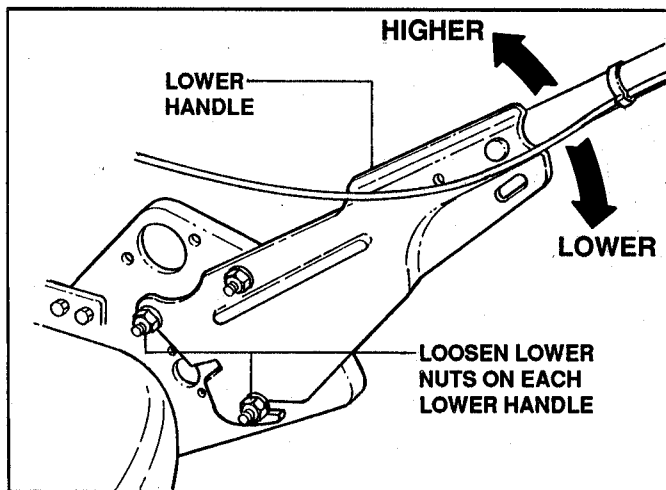

FIGURE 2.3

2. Move upper mower handle up or down until it is at a comfortable operating position.
3. Tighten the lower nuts on each lower handle to maintain adjustment.

2.6 CUTTING HEIGHT ADJUSTMENT



WARNING!



Stop engine and mower blade before adjusting cutting height.

- A. Pull the height adjusting latch outward towards the wheel and move to desired notch. See Figure 2.4.

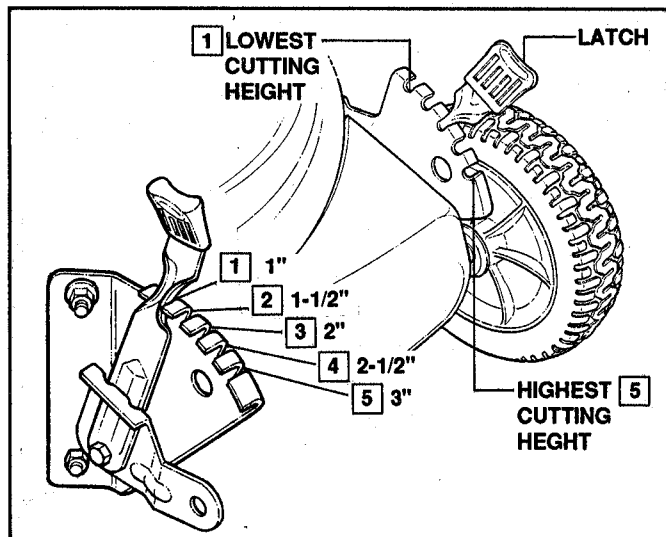

FIGURE 2.4

- B. Set all wheels at same cutting height. The highest cutting position is Notch 5; the lowest cutting position is Notch 1. See Figure 2.5 for example of cutting height settings.

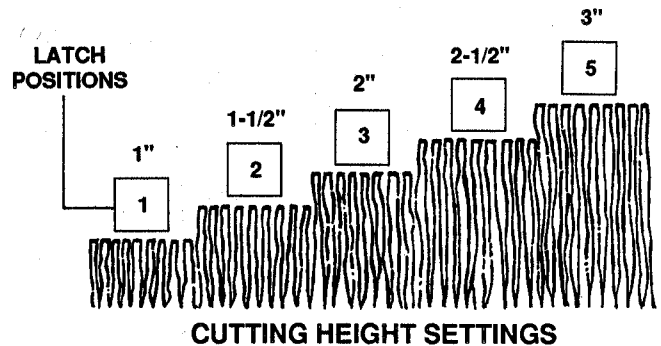

FIGURE 2.5

2.7 RECYCLING OPERATION

NOTE

For best recycling results, cut up to a maximum of 1" from grass and recycle **ONLY** when grass is dry.

- A. Set all wheels in the highest cutting position (Notch 5).
- B. Move engine speed control lever to "FAST" (⚡) position.
- C. Move ground speed control lever to lowest setting.
- D. Proceed mowing slowly. If grass is very dense, lower each rear wheel latch one notch lower than the front wheel latches to improve recycling performance.



WARNING



Stop engine and mower blade before adjusting cutting height.

2.8 MOWING PROCEDURE

A. PUSH MODEL MOWERS

1. Start engine.
2. Push mower forward at a speed best suited for the lawn being mowed.
3. Stop engine by releasing the blade control.

B. SELF-PROPELLED MOWERS

1. Start engine.
2. Set the ground speed control lever at the desired speed. See Figure 2.6.

Section II - OPERATING INSTRUCTIONS

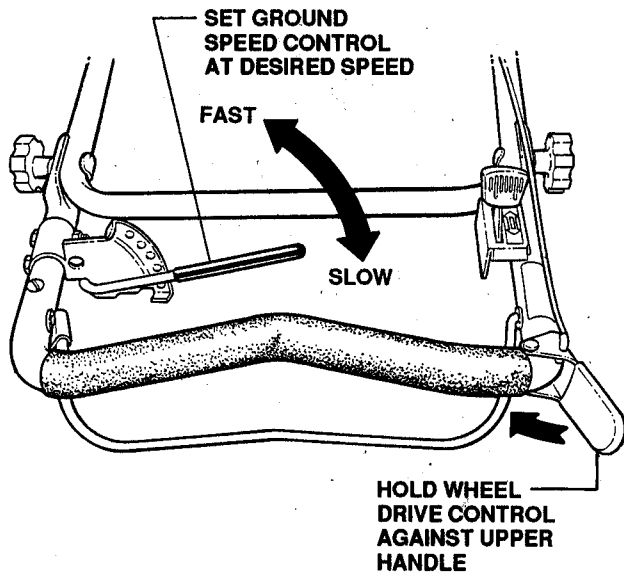

FIGURE 2.6

3. Hold the wheel drive control against the upper handle. The mower will now begin to move forward. To stop forward motion, release the wheel drive control. The mower can then be pushed forward or pulled backward for trimming. Refer to Figure 2.6.
4. Release blade control to stop engine and blade.

2.8 EMPTYING GRASS BAG

- A. Stop engine.
- B. Lift rear of bag up and over the lower handle. See Figure 2.7.

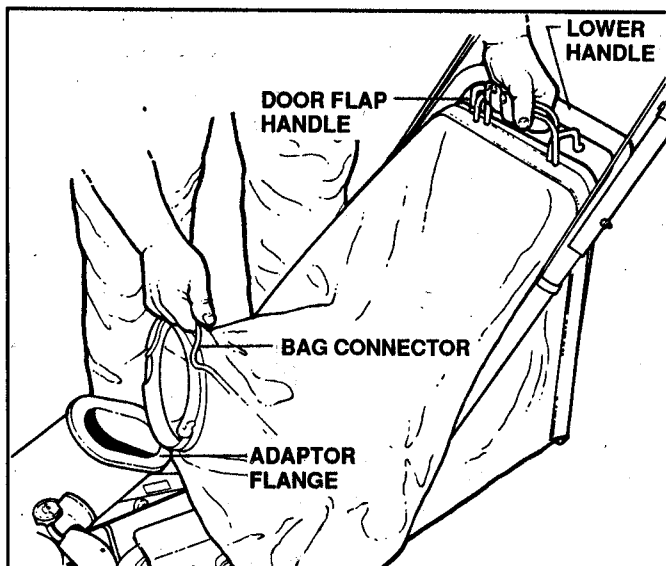

FIGURE 2.7

- C. Lift the bag connector off the adaptor flange.
- D. Lift bag up and move bag forward until it clears the mower.
- E. To empty the bag, raise the connector end up and release the handle of the door flap.
- F. Shake the bag to dump the grass clippings.
- G. Close the door flap.

2.9 INSTALLING GRASS BAG

- A. Slide the bag connector down over the adaptor flange.
- B. Lower the bag wire support hooks onto the lower handle.

Section III - MAINTENANCE

3.1 INTRODUCTION

To retain the quality of the mower, use genuine SNAPPER replacement parts only. Contact a local SNAPPER dealer for parts and service assistance. For the correct part or information for a particular mower, always mention model and serial number. SNAPPER recommends returning the mower to an authorized SNAPPER dealer on a yearly basis for inspection and addition of any new devices which might upgrade the safety of the mower. For the nearest SNAPPER dealer, check the yellow pages under the heading LAWN MOWERS. For engine parts and service, look for the engine manufacturer's dealers under the heading ENGINES - gasoline.

3.2 SERVICE - AFTER FIRST 5 HOURS

A. CHANGE ENGINE OIL

1. Disconnect spark plug wire and secure end away from plug.
2. Tilt mower up on its rear wheels for access to the oil drain plug located underneath the mower deck. Do not tilt mower with spark plug or carburetor down. See Figure 3.1

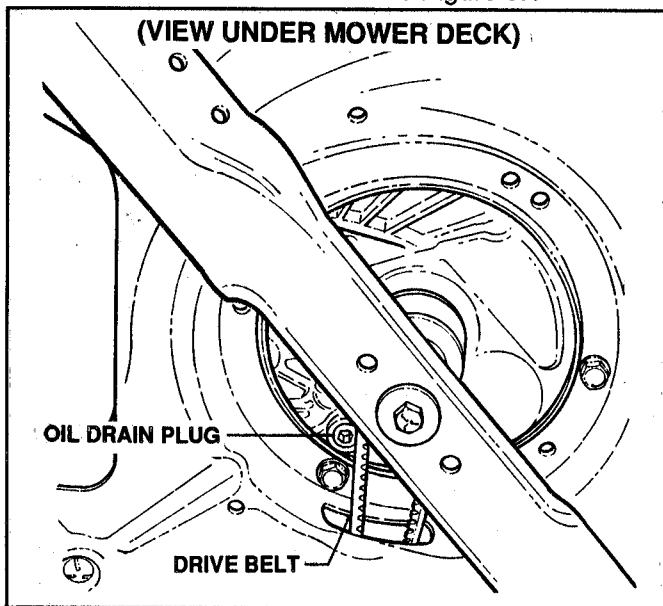

FIGURE 3.1

3. Place a flat, two-quart container underneath the approximate center of the oil drain plug.
4. Place a protective cover over drive belt (self-propelled models) to protect the belt from oil, then remove oil drain plug.
5. Lower mower over container and remove oil fill cap and dipstick from engine.
6. Allow oil to drain completely.
7. Tilt mower up and replace oil drain plug.
8. Wipe away any excess oil and remove protective cover from drive belt.

9. Fill engine with oil as specified in Engine Owner's Manual. Thereafter, change oil after each 25 hours of use.

B. CHECK LEVEL OF GREASE IN TRANSMISSION

1. Remove transmission fill plug. See Figure 3.2.

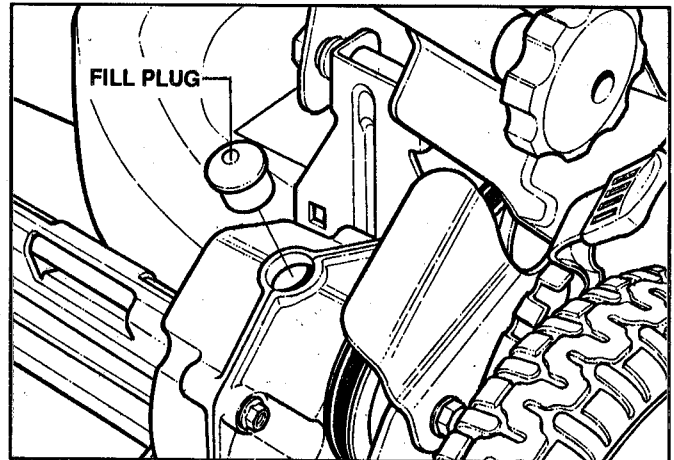

FIGURE 3.2

2. Look into plug hole. If grease IS NOT visible on the input gear (the small gear below the plug hole), add a small amount of SNAPPER "00" grease.

NOTE

SNAPPER "00" Grease (Part No. 6-1017) is available at your SNAPPER dealer.

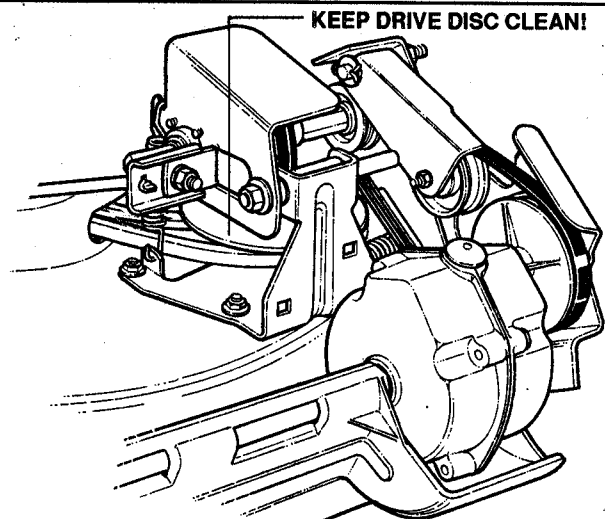
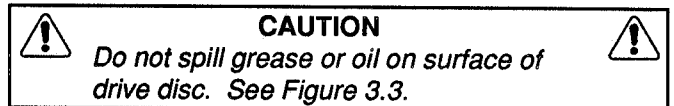

FIGURE 3.3

3. Reinstall transmission plug.
4. Thereafter, check grease level after each 25 hours of operation.

Section III - MAINTENANCE

C. CHECK TORQUE OF BLADE CAPSCREW

1. Disconnect spark plug wire and secure end away from plug.
2. Tilt mower up on its rear wheels for access to the blade capscrew. Do not tilt mower with spark plug or carburetor down. See Figure 3.4
3. Check torque value of blade retaining capscrew. It should be 30 ft. lbs. torque. See Figure 3.4

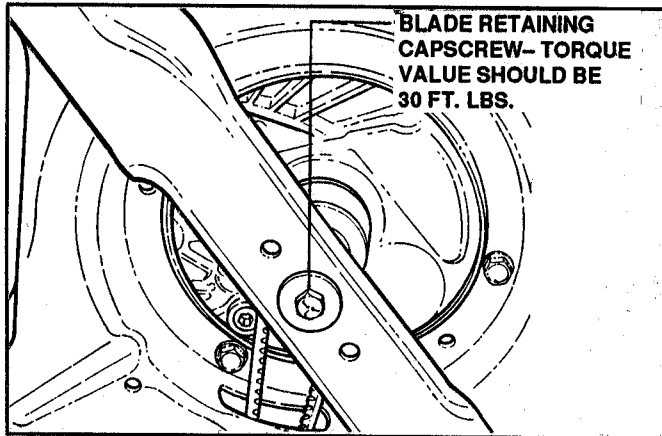

FIGURE 3.4

4. Thereafter, check torque value of blade retaining capscrew after each 25 hours of use.

3.3 MOWER BLADE REPAIR/REPLACEMENT

A. STANDARD BLADE WEAR LIMIT

1. Inspect blade frequently for signs of wear or damage. See Figure 3.5.

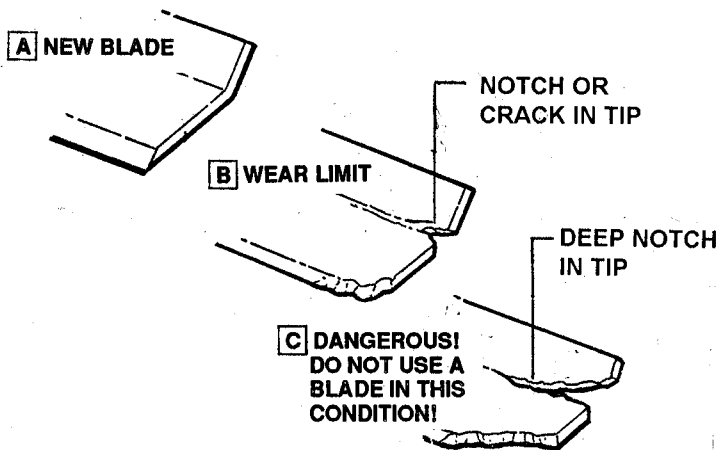

FIGURE 3.5

2. Refer to Figure 3.5 to determine blade condition. Replace the blade if it is badly chipped, bent, noticeably out of balance or has cracks or notch in either tip as shown in example B above. Replace with new blade Part No. 2-6691.

WARNING

Never operate the mower with a blade worn to the extent shown in example "C", the "tip" could fly off and cause personal injury or property damage.

B. RECYCLING (NINJA) BLADE WEAR LIMIT

1. Figure 3.6 shows some examples of wear conditions found on SNAPPER's special blade (NINJA) for recycling model mowers. This blade should be inspected more often than standard blades and special attention should be taken to make sure that the blade is kept in good condition.

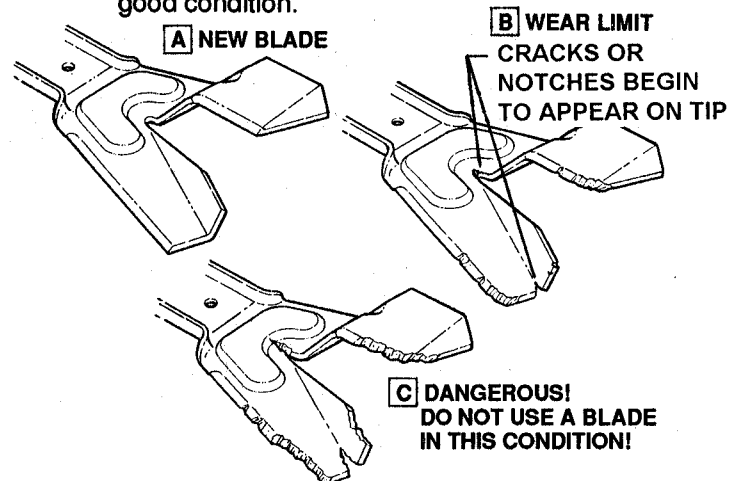

FIGURE 3.6

2. Refer to Figure 3.6 to determine blade condition. Replace the blade if it is badly chipped, bent, noticeably out of balance or has cracks or notch in either tip as shown in example B above. Replace with new blade Part No. 2-4234.

C. BLADE SHARPENING

1. Disconnect spark plug wire and secure end away from plug.
2. Tilt mower up on its rear wheels. Do not tilt mower with spark plug or carburetor down.
3. Remove blade. See Figure 3.7

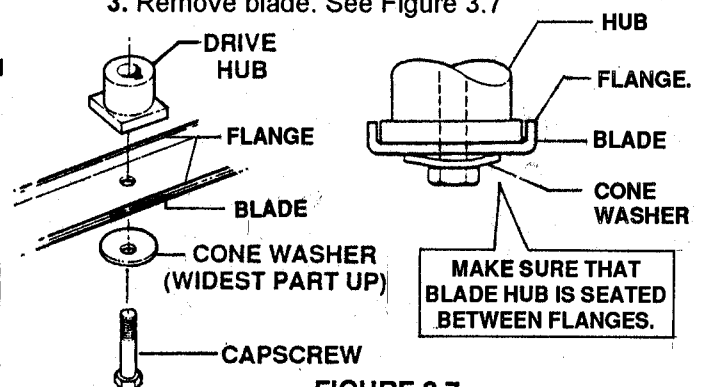

FIGURE 3.7

4. Sharpen blade on a grinding wheel at an angle of 22 to 28 degrees. The cutting surface should extend inward about 3 1/2" from the tip. See Figure 3.8.

Section III - MAINTENANCE

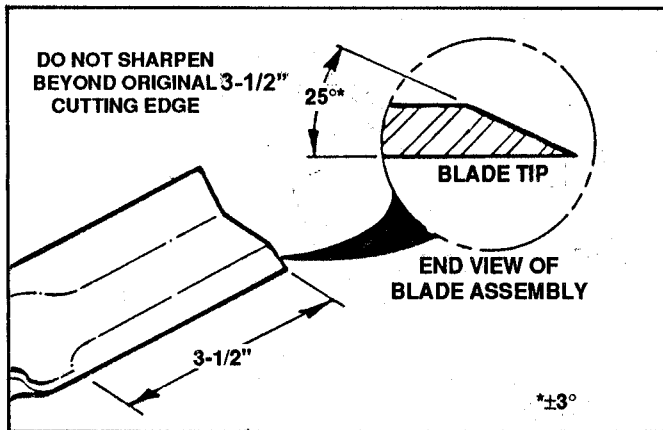

FIGURE 3.8

5. Check blade for balance. If necessary, correct balance by grinding heavy end of blade.
6. Reinstall blade. Refer to Figure 3.7. Torque blade mounting capscrew to 30 ft. lbs.

3.4 WHEEL DRIVE CONTROL ADJUSTMENT

- A. The wheel drive control is properly adjusted when there is 1/16" to 1/8" clearance between the inside of the spring hook and the inside of the clutch cable eye with the wheel drive control released. See Figure 3.9.

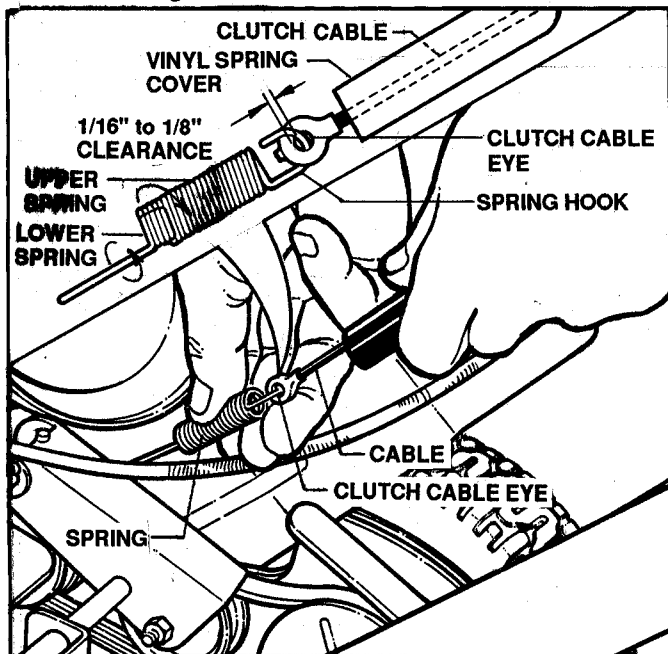

FIGURE 3.9

- B. To adjust, unhook upper spring from cable eye and rotate spring in direction required to extend or shorten spring length.
- C. Rehook upper spring to cable eye and check clearance. Repeat procedure if required.

NOTE

The vinyl spring cover should be kept over the spring at all times except for adjustments.

- D. If the wheel drive control fails to return quickly to the "OFF" position when released, check for binding at the cable holdings located on the side of the right handle. The upper clip should be located 2" below the center of the upper knob; the lower clip should be 4" above the center of the lower knob. The cable should slide freely with the clips installed at these locations. See Figure 3.10.

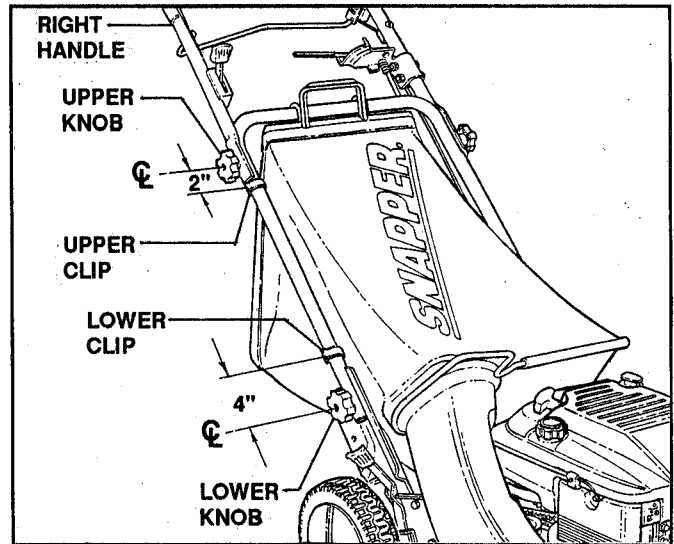

FIGURE 3.10

3.5 DRIVEN DISC SERVICE

If the mower does not pull properly, refer to Figure 3.11, and check for the following problems:

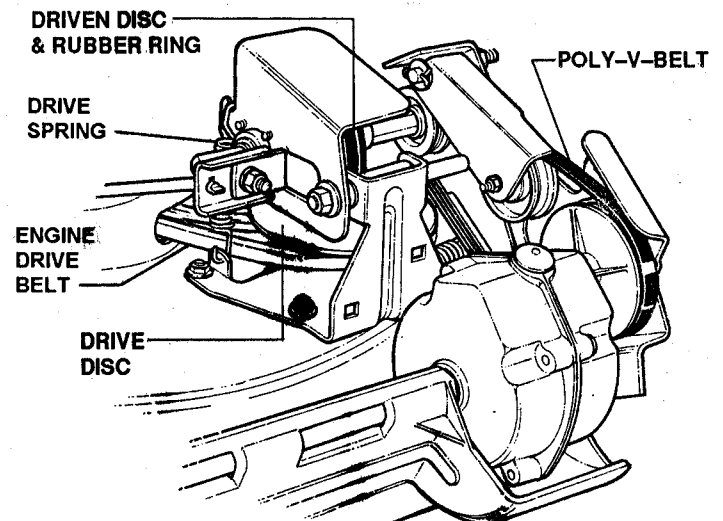

FIGURE 3.11

- A. Grease on drive disc causing slippage.
 - B. Broken or disconnected drive spring.
 - C. Driven disc is out of adjustment.
 - D. Driven disc rubber ring is worn - does not contact drive disc properly.
 - E. Worn poly-v-belt or engine drive belt.
- If any of the above (A thru E) are causing problems, service as follows:

Section III - MAINTENANCE

1. Cleaning Drive Disc & Driven Disc.

If oil or grease on the drive disc or driven disc is causing slippage, stop the engine and clean discs as follows:

- (a) Wipe away any oil or grease with a clean cloth.
- (b) Use either an approved grease solvent or hot, soapy water to clean drive disc or driven disc.
- (c) Rinse components with clean water.
- (d) Dry components with a clean cloth.

2. Drive Spring Repair/Replacement

If drive spring is loose, reconnect as shown in Figure 3.12. If spring is broken, replace with new spring, Part No. 1-7326.

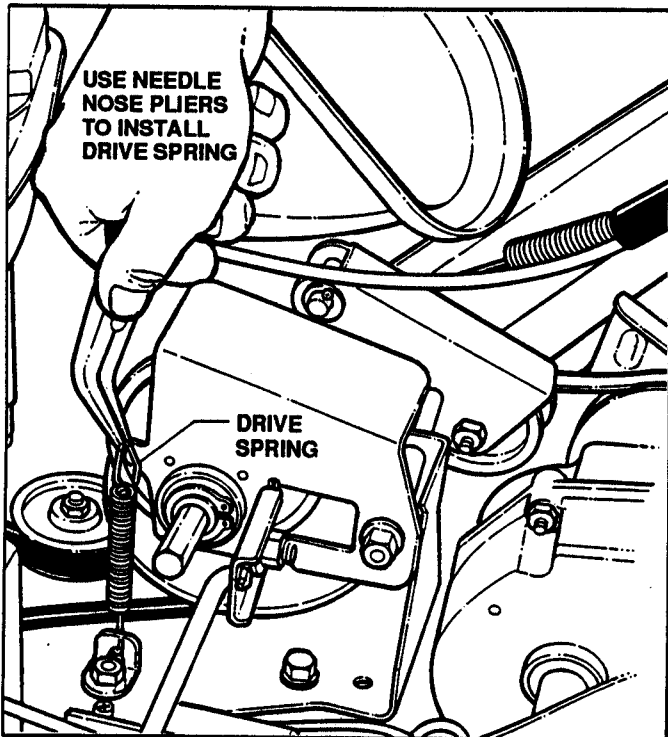

FIGURE 3.12

3. DRIVEN DISC ADJUSTMENT

If the drive disc and driven disc are clean and the mower drive is not making correct drive disc and driven disc contact, adjust the driven disc as follows:

- (a) Place ground speed control in the number six speed position. See Figure 3.13.

MOVE GROUND SPEED CONTROL TO SIX SPEED POSITION

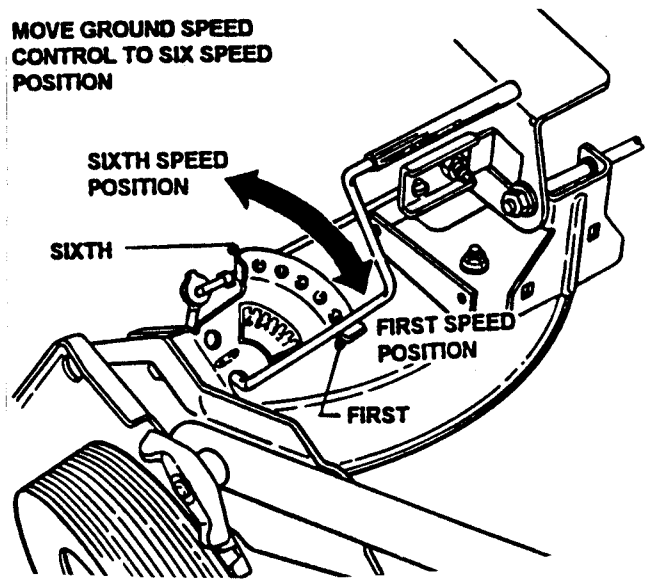

FIGURE 3.13

- (b) Remove driven disc spring from driven disc assembly. Loosen connector hex nut. See Figure 3.14.A.

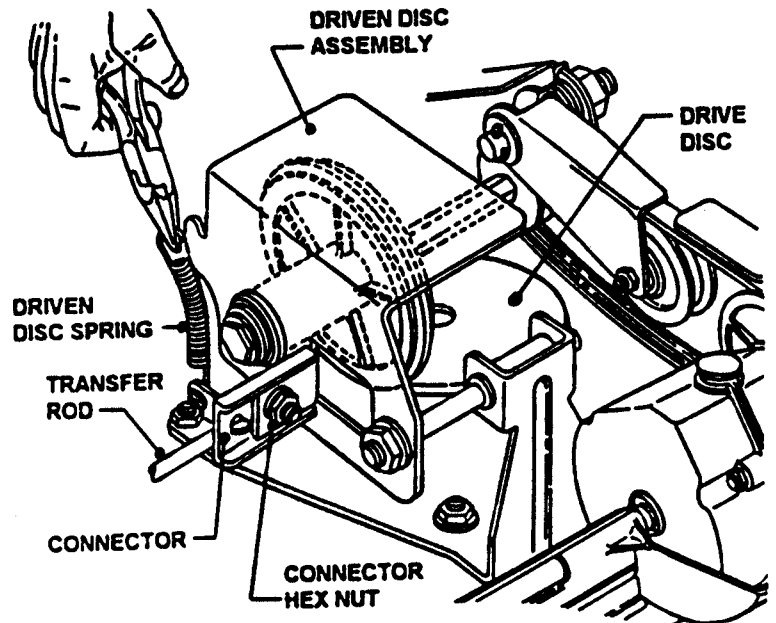

FIGURE 3.14.A

- (c) Slide driven disc assembly over to 1/8" from outside edge of drive disc. Maintaining the 1/8" measurement, remove any looseness from the linkage. This can be done by holding the transfer rod and applying pressure to the left (as viewed from operators position). Then retighten the connector hex nut securely. See Figure 3.14.B. Move ground speed control to the first speed position, then back to the sixth speed position. Recheck the 1/8" measurement described previously. Reinstall driven disc spring to driven disc assembly.

Section III - MAINTENANCE

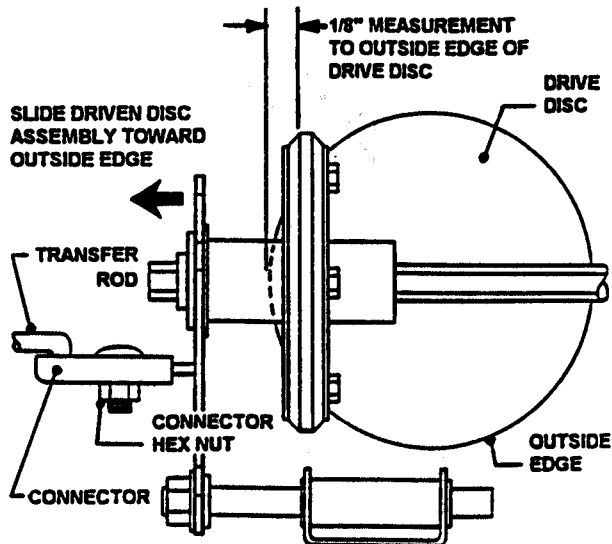

FIGURE 3.14.B

4. Replacing Driven Disc Rubber Ring

If the rubber ring is badly chunked or worn down to within 1/16" of the metal rim of the driven disc hub, it must be replaced. Install new rubber ring as follows:

- (a) Using a small flat blade screwdriver, free the clip from the transfer rod. Then remove the transfer rod from the clip and the speed control rod. See Figure 3.15

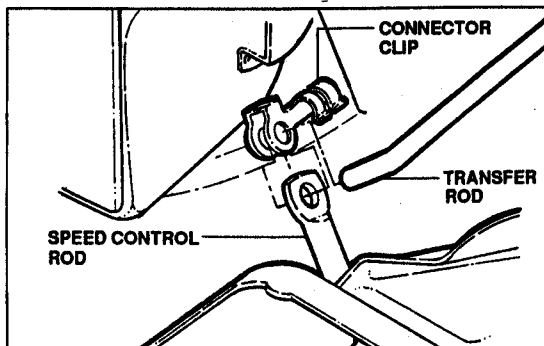

FIGURE 3.15

- (b) Using needle nose pliers, unhook the drive spring and slide the driven disc assembly off the hex shaft. See Figure 3.16.

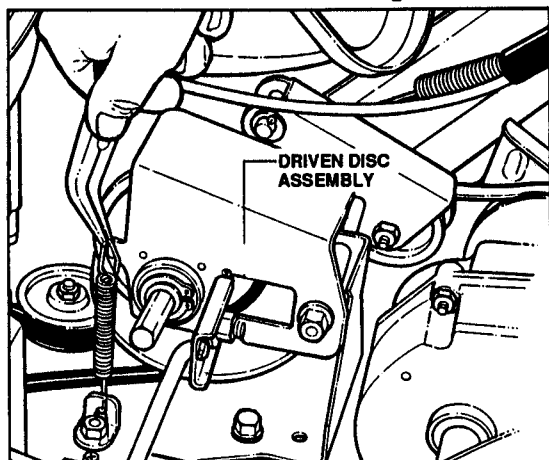

FIGURE 3.16

- (c) Remove the five machine screws and plate which secure the rubber ring to the driven disc hub. See Figure 3.17.

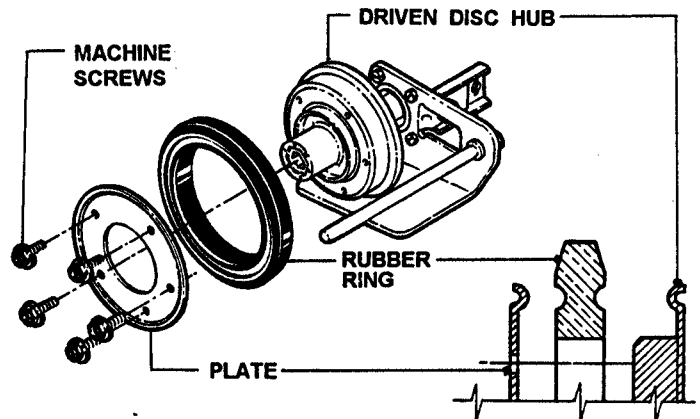

FIGURE 3.17

- (d) Install new rubber ring, Part No. 2-3364.

- (e) Reverse above procedures for reassembly and installation.

5. Replacing Bearing in Driven Disc

If the driven disc bearing fails, remove the driven disc assembly as described above and replace bearing as follows:

- (a) Remove snap ring. See Figure 3.18.

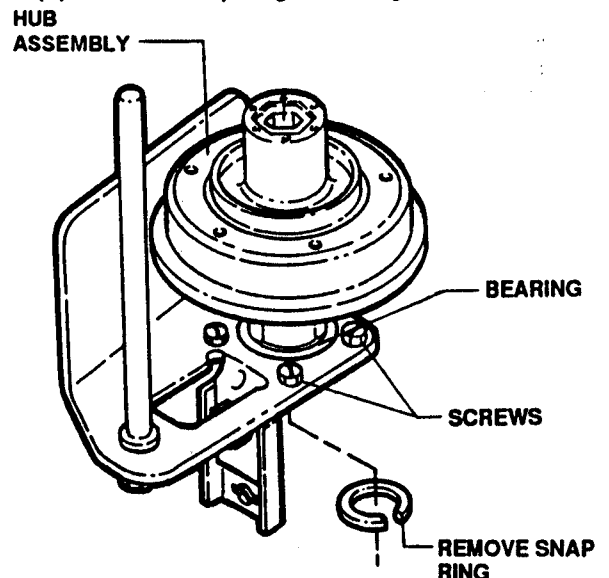

FIGURE 3.18

- (b) Slide the hub assembly out of the bearing.

- (c) Remove the four screws.

- (d) Remove bearing and replace with new bearing, Part No. 1-5474.

- (e) Reassemble components in reverse order.

Section III - MAINTENANCE

6. Replacement of Bearing on Pulley End of Hex Shaft

To replace the bearing on the pulley end of the hex shaft, proceed as follows:

- (a) Hold the hex shaft with an adjustable wrench held next to the pulley.
- (b) Remove the 3/8" hex lock nut which is located on the outside of the right wheel bracket. See Figure 3.19.

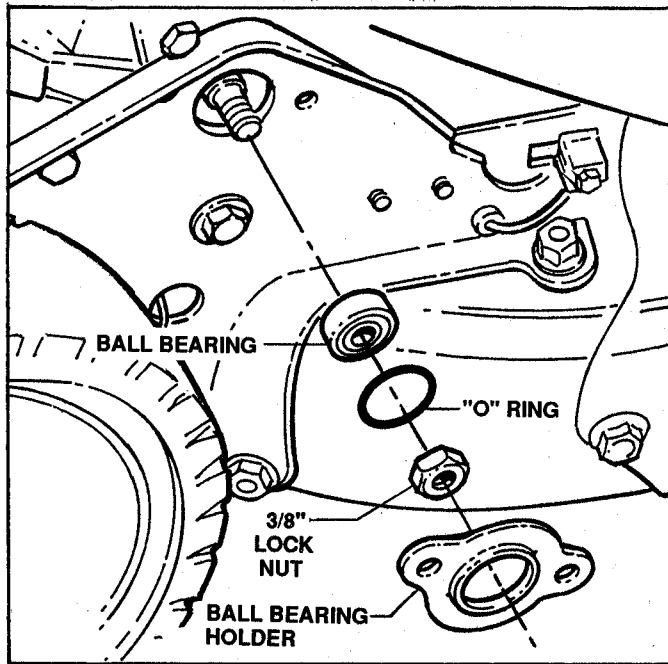

FIGURE 3.19

- (c) Remove holder, o-ring and bearing.
- (d) Install new bearing, Part No. 2-8014.
- (e) Carefully install new o-ring, Part No. 1-1025, over the outside of the new bearing.
- (f) Install bearing holder and secure with screws.
- (g) Install 3/8" hex lock nut.

3.6 BELT SERVICE

On self-propelled mowers, the engine belt transmits power to the Poly-V-Belt, which in turn, engages the clutch to drive the transmission and rear drive wheels. Should these belts become worn, they could cause slippage which would impair mower performance. The condition of the engine belt and Poly-V-Belt should be checked after every 25 hours of mower operation.

A. ENGINE DRIVE BELT REPLACEMENT

1. Disconnect spark plug wire and empty the fuel tank.
2. Unhook the idler spring from the right rear wheel bracket. See Figures 3.20 and 3.21.

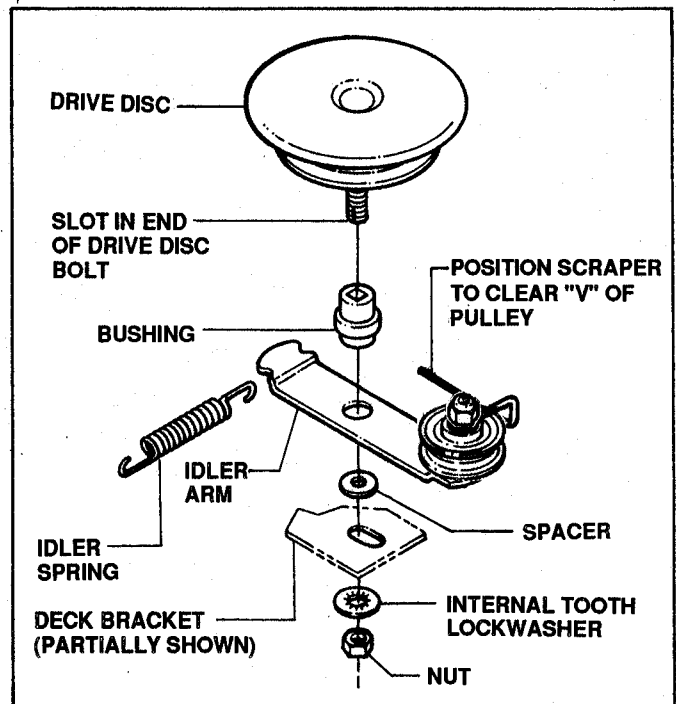
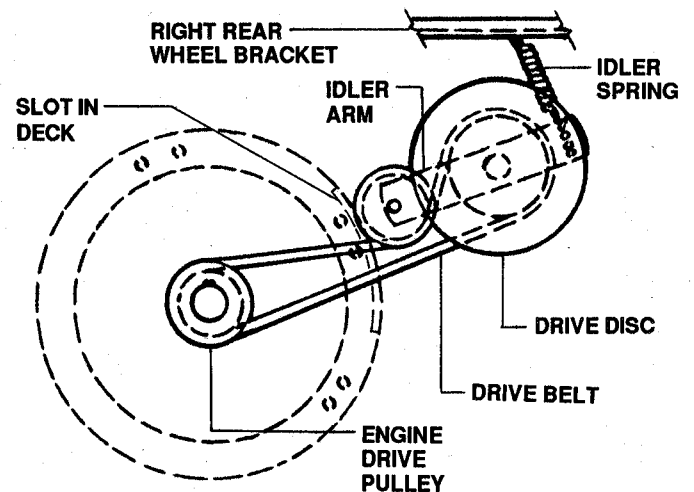

FIGURE 3.20

3. Remove the driven disc. Refer to "4. REPLACING DRIVEN DISC RUBBER RING" for driven disc removal procedure.
4. Tilt mower up on its rear wheels and remove blade and blade hub. Do not tilt mower with spark plug or carburetor down.
5. Hold the slotted end of the drive disc bolt with a screwdriver and remove the nut and internal tooth lockwasher. Refer to Figure 3.20.
6. Lift the drive disc off the idler arm and remove worn belt.
7. Loop one end of new belt, Part No. 1-2353, over engine pulley and insert the other end through slot in deck. See Figure 3.21.



TOP VIEW OF ENGINE BELT ROUTING

FIGURE 3.21

Section III - MAINTENANCE

8. Loop the belt around the pulley on the bottom of the drive disc.
9. Reinstall drive disc and other components as shown in Figure 3.20.
10. Reinstall cutter blade. Torque retaining capscrew to 30 ft. lbs.
11. Use a stiff wire, such as a coat hanger, with a hook fashioned on one end to pull the hooked end of the idler spring through the large hole in the right wheel bracket.
12. If the Poly-V-Belt is NOT going to be replaced at this time, reinstall the driven disc assembly.

B. POLY-V-BELT REPLACEMENT

1. Remove driven disc assembly. Refer to "4. Replacing driven disc rubber ring" for procedure.
2. Note the routing of the old belt around the three pulleys before cutting and removing it. See Figure 3.22.

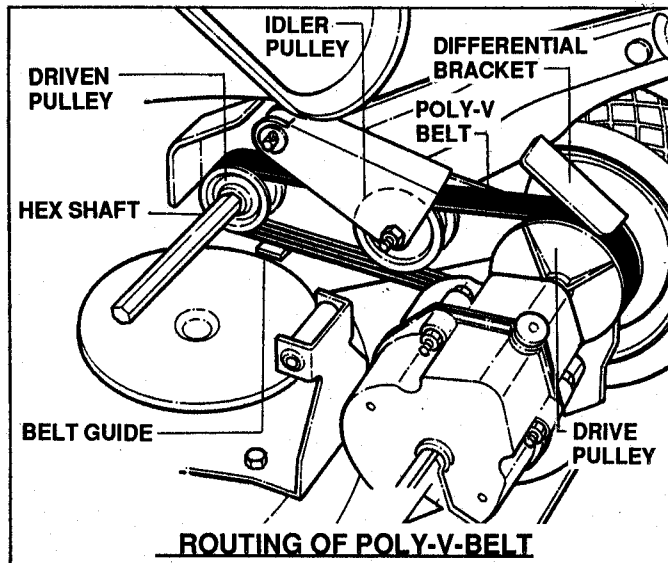

FIGURE 3.22

3. Place new Poly-V-Belt, Part No. 1-2354, over end of hex shaft and onto driven pulley.
4. Work belt onto top of idler pulley.
5. Twist belt sideways and pull it upward between the differential bracket and drive pulley and then down into the pulley groove. Make sure poly-v belt is above belt guide. See Figure 3.22.

8.7 STORAGE PROCEDURE

- A. Refer to the engine manual for directions regarding engine storage preparations.
- B. Prepare the mower for "end of season" storage as follows:

1. **DISCONNECT THE SPARK PLUG WIRE BEFORE ANY OTHER PREPARATIONS ARE MADE!**
2. Tape all openings closed to prevent spraying water into exhaust or air intakes during washing.
3. Tilt mower up on its rear wheels and thoroughly clean the underside of the deck. Do not tilt mower with spark plug or carburetor down. Scrape away any accumulation of grass with a putty knife and or wire brush.
4. Lubricate all exposed metal with a light coating of oil to prevent corrosion.
5. If so equipped, empty the grass bag to prevent decay of debris and formation of mold while in storage. The grass bag may be washed in detergent, but allow it to dry thoroughly.
6. Store the mower in a shed or other dry area, protected from weather.
7. Handles may be folded forward AFTER loosening both lower knobs. Grass bags and adapters do not need to be removed.
 - (a) Prior to folding handles on self-propelled models, disconnect the transfer rod clip. See Figure 3.15.
 - (b) Carefully fold the handles forward, "flexing" the control cables to prevent cable damage.

SNAPPER®

2 YEAR LIMITED WARRANTY

For two (2) years from purchase date for the original purchaser's residential, non-commercial use, SNAPPER, through any SNAPPER dealer will replace, free of charge, any part or parts found upon examination by the factory at McDonough, Georgia, to be defective in material or workmanship or both.

For ninety (90) days from purchase date for the original purchaser's commercial, rental, or other non-residential use, SNAPPER, through any SNAPPER dealer will replace, free of charge, any part or parts found upon examination by the factory at McDonough, Georgia, to be defective in material or workmanship or both.

All transportation costs incurred by the purchaser in submitting material to a SNAPPER dealer for replacement under this warranty must be paid by the purchaser.

This warranty does not apply to engines and their components, or, Peerless® Transaxles, as these items are warranted separately by their manufacturers. This warranty does not apply to parts that have been damaged by accident, alteration, abuse, improper lubrication, normal wear, or other cause beyond our control.

There is no other express warranty.

Implied warranties, including those of merchantability and fitness for a particular purpose, are limited to two (2) years from purchase date for the original purchaser's residential, non-commercial use [ninety (90) days from purchase for the original purchaser's commercial, rental or other non-residential use], and to the extent permitted by law, any and all implied warranties are excluded. This is the exclusive remedy. Liabilities for consequential damages, under any and all warranties are excluded.

Some states do not allow limitations on how long an implied warranty lasts, or do not allow the exclusion or limitation of incidental or consequential damages, so the above limitation or exclusion may not apply to you.

This warranty gives you specific legal rights, and you may also have other rights which vary from state to state.

WARNING: THE USE OF REPLACEMENT PARTS OTHER THAN GENUINE SNAPPER PARTS MAY IMPAIR THE SAFETY OF SNAPPER PRODUCTS AND WILL VOID ANY LIABILITY AND WARRANTY BY SNAPPER ASSOCIATED WITH THE USE OF SUCH PARTS.

IMPORTANT: Please fill out the attached SNAPPER Product Registration Card immediately and mail to:
SNAPPER, McDONOUGH, GEORGIA 30253

Safety Instructions & Operator's Manual for

SNAPPER®

21" STEEL DECK WALK BEHIND MOWER - SERIES 0 & 1 MODELS

21500, R21500, P21550, RP21550, RP21550T2, EP21450, EP21550, D21500
DP21500, RP21600, EP21600, P21600TV, R21501, RP21501, NR21501, NRP21501

ACCESSORIES

Below is a list of popular accessories for the SNAPPER Series 0 Walk Mowers. Contact an authorized SNAPPER dealer under Lawnmowers in the yellow pages to obtain any of these accessories.

SNAPPER WALK BEHIND MOWER ACCESSORIES 21" STEEL DECK

PART NO.	DESCRIPTION	MODELS USED ON
6-0791	GRASS CATCHER (Slider Door)	21" MODELS
6-0856	GRASS CATCHER (w / Adapter) (Kwik-N-Ezy)	21" MODELS
6-0932	GRASS CATCHER (Kwik-N-Ezy)	21" SERIES 4, 5, 6, 7, 8, 9
6-0935	GRASS CATCHER (w / Adapter) (Kwik-N-Ezy)	21" SERIES 4, 5, 6, 7, 8, 9
6-1238	GRASS CATCHER (w / Adapter) (Kwik-N-Ezy)	21" SERIES 0
6-1280	GRASS CATCHER (Kwik-N-Ezy)	21" (RO21380 Models Only)
6-0933	GRASS CATCHER (Kwik-N-Ezy)	21" (Commercial Models Only)
6-0936	GRASS CATCHER (Slider Door)	21" (Commercial Models Only)
6-1006	GRASS CATCHER (w / Adapter) (Slider Door)	21" (Commercial Models Only)
6-1153	GRASS CATCHER	21" (OPP Models Only)
6-1003	GRASS CATCHER BAG LINERS (10 to a Pack)	21" MODELS
6-1030	RECYCLING KIT (Cover) (Below 4 HP Engines)	21" MODELS (Series 9)
6-1032	RECYCLING KIT (Plug) (Below 4 HP Engines)	21" MODELS (Series 9)
6-1200	RECYCLING KIT (Ninja Cover) (4 HP Engines & Above)	21" MODELS (Series 0)
6-1201	RECYCLING KIT (Ninja Plug) (4 HP Engines & Above)	21" MODELS (Series 0)
6-0440	SNAPPERIZER KIT	21" MODELS
6-0960	THATCHERIZER KIT	21" MODELS
6-0965	THATCHERIZER ADAPTER KIT	21" SERIES 6, 7
6-0955	SIDE DISCHARGE CHUTE KIT	21" MODELS
6-1302	SIDE DISCHARGE CHUTE KIT (w / Blade)	21" (RO21380 Models Only)
6-0785	AIR LIFT KIT	21" MODELS
6-0658	ELECTRIC START KIT	MODEL YEAR 1971 TO 1976
6-0766	BATTERY CHARGER KIT	21" SERIES 5, 6, 7
6-1188	BATTERY CHARGER KIT	21" SERIES 9, 0
6-7012	BATTERY KIT (WET CELL)	21" SERIES 5, 6, 7, 8, 9, 0
6-1152	CROSSBAR KIT	21" SERIES 0

WARNING: The engine exhaust from this product contains chemicals known to the State of California to cause cancer, birth defects or other reproductive harm.

SNAPPER® McDonough, GA., 30253 U.S.A.