

Safety Instruction & Operator's Manual

SNAPPER 21" HI-VAC

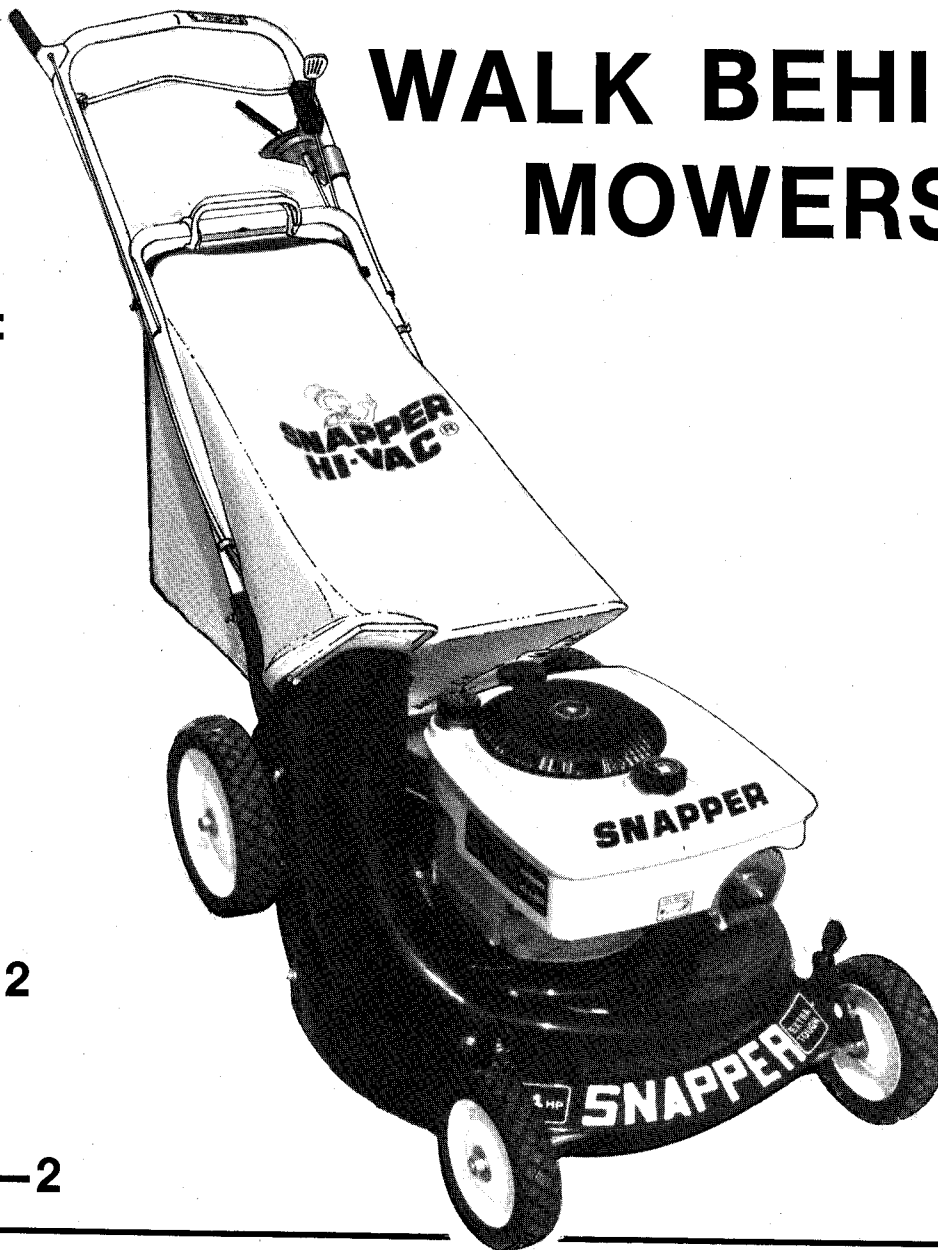

WALK BEHIND MOWERS

MODELS:

21351
21351D
21351PD

21401
21401S
21401P
21401PS
21401PD

214X1
214X1R
214X1R-2
214X1P
214X1PS
214X1PR
214X1PR-2

*Thank you for buying a SNAPPER product! Before operating your mower, read this manual carefully and pay particular attention to the **Important Safety Instructions** on page 2. Remember that mowers and all power equipment can be dangerous if used improperly and keep in mind that safety requires careful use in accordance with the instructions and . . . common sense!*

This manual covers all Snapper 21" design series 1 (last numeral in the five digit model designation) walk behind mowers. Models without letter suffixes following the five digit designation are push models equipped with Kwik-N-Ezy grass catcher. The letter suffix **D** indicates side discharge, **P** indicates self-propelled, **S** indicates electric start, **R** indicates a premium engine and **X** in the fourth digit indicates an **extra tough** version. The **-2** suffix indicates the unit is powered by a 2-cycle engine. Differences are pointed out wherever pertinent throughout the manual.

SNAPPER POWER EQUIPMENT

McDonough, GA • 30253



MANUAL 1-4322
REVISION 4 (7/86)

IMPORTANT SAFETY INSTRUCTIONS

WARNING: Failure to comply with the following instructions may result in serious injury to the operator or other persons. The owner of the mower must understand these instructions and, furthermore, must allow only persons who understand these instructions to operate the mower. Each person operating the mower must be of sound mind and body and must not be under the influence of any substance which might impair vision, dexterity, or judgement. If you have any questions pertaining to your mower which your dealer cannot answer to your satisfaction, call or write the Customer Service Department at SNAPPER POWER EQUIPMENT, McDonough Georgia, 30253. (Phone 404-957-9141).

TRAINING

1. Read this Manual carefully and question your dealer if something is not clear. Should the dealer be unavailable or unable to answer to your satisfaction, write or call our Customer Service Department at the factory. Be thoroughly familiar with the controls and proper use of the equipment.
2. DO NOT allow children in yard when mower is operated.
3. DO NOT allow pre-teenager children to operate mower.
4. Only responsible teenagers with mature judgement shall be allowed to operate mower and only under close supervision.
5. Keep the area clear of all persons, particularly small children, and pets.

PREPARATION

1. Never operate mower without proper guards, plates, safety switches, or other safety protective devices in place and properly connected. Inspect to determine that these safety devices are installed properly, are in good repair, and operate properly. If the condition or operation of these devices are questionable, they must be repaired or replaced before using the mower.
2. Thoroughly inspect the area where the mower is to be used and remove all stones, sticks, wire, bones and other foreign objects. Also note the location of holes, stumps, and other possible hazards.
3. Do not operate mower when barefoot or wearing open sandals. Always wear substantial footwear and long pants.
4. Fill gasoline tank before starting engine. Use approved gasoline container. Do not smoke near open gasoline container. Do not fill gasoline tank indoors or when engine is running. Allow engine to cool for at least ten minutes before refilling. Wipe off any spilled gasoline before starting engine. Do not run engine indoors.
5. Make sure that the traction drive clutch control is disengaged before starting engine.
6. Never attempt to make a wheel height adjustment while the engine is running.
7. When mowing over rough ground or in tall grass, mower must be set in highest cutting position.
8. Mow only in daylight or in good artificial light.
9. Never operate mower in wet grass. Always be sure of your footing; keep a firm hold on the handle and walk; never run.

OPERATION

1. Do not change engine governor settings or overspeed engine.
2. Do not put hands or feet near or under rotating parts. Keep clear of discharge area while engine is running.
3. Stop engine when crossing gravel drives, walks, or roads, and under any conditions where thrown objects might be a hazard.
4. After striking a foreign object or if mower vibrates abnormally, stop the engine, disconnect and secure spark plug wire. Inspect the mower for any damage and repair the damage.
5. Stop engine whenever you leave the operating position behind the handle for any reason, including emptying grass bag and making any adjustments, repairs, or inspections.
6. Before cleaning, repairing or inspecting, make certain blade and all moving parts have stopped. Disconnect and secure spark plug wire away from plug to prevent accidental starting.
7. Stop engine and wait until the blade comes to complete stop before removing grass bag and/or unclogging adapter.
8. Mow across steep slopes, never up-and-down. Exercise caution when changing directions on slopes. Do not mow excessively steep slopes.

MAINTENANCE AND STORAGE

1. Keep all nuts, bolts, and screws tight to be sure mower is in safe operating condition.
2. Never store mower with gasoline in the tank inside of a building where fumes may reach an open flame or spark. Allow engine to cool before storing in any enclosure.
3. To reduce fire hazard, keep mower free of grass, leaves or excessive grease.
4. Check grass bag assembly frequently for wear or deterioration. Replace with new bag if loose seams or tears are evident. Replace slider or bag adapter if broken or cracked.
5. Have your mower inspected and serviced each year by an authorized Snapper dealer. Determine if any additional devices are available which might upgrade the safety of your mower.
6. Factory specified Snapper replacement parts must be used to assure adequate protection against injury.

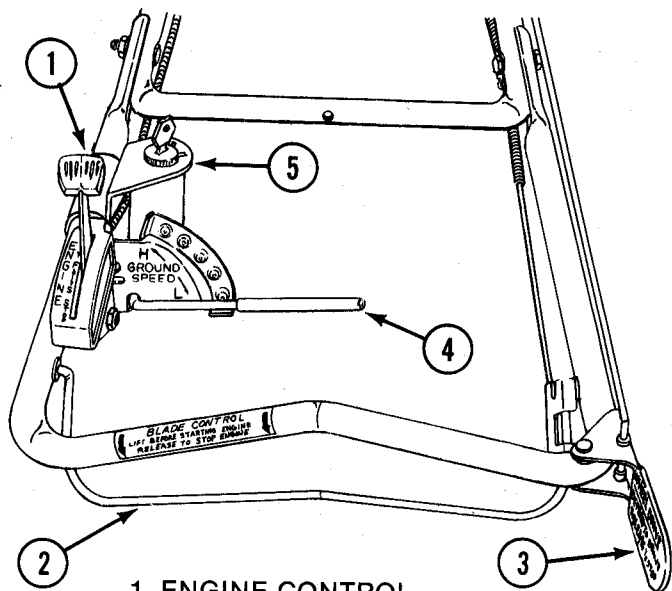

1. ENGINE CONTROL
2. BLADE CONTROL
3. WHEEL DRIVE CONTROL
4. GROUND SPEED CONTROL
5. ELECTRIC START KEYSWITCH

FIGURE 1 - LOCATION OF CONTROLS

OPERATING PROCEDURE

Keep the important safety instructions in mind when operating the mower. For easier starting, move the mower to an area where the cutting blade can turn free of tall grass. Know beforehand how to stop the mower in preparation for possible emergencies. The engine (and blade) is stopped by releasing the BLADE CONTROL or by pulling the ENGINE CONTROL rearward to STOP position. Forward motion of self-propelled models is stopped by releasing the WHEEL DRIVE control. Refer to figure 1 for location of these controls.

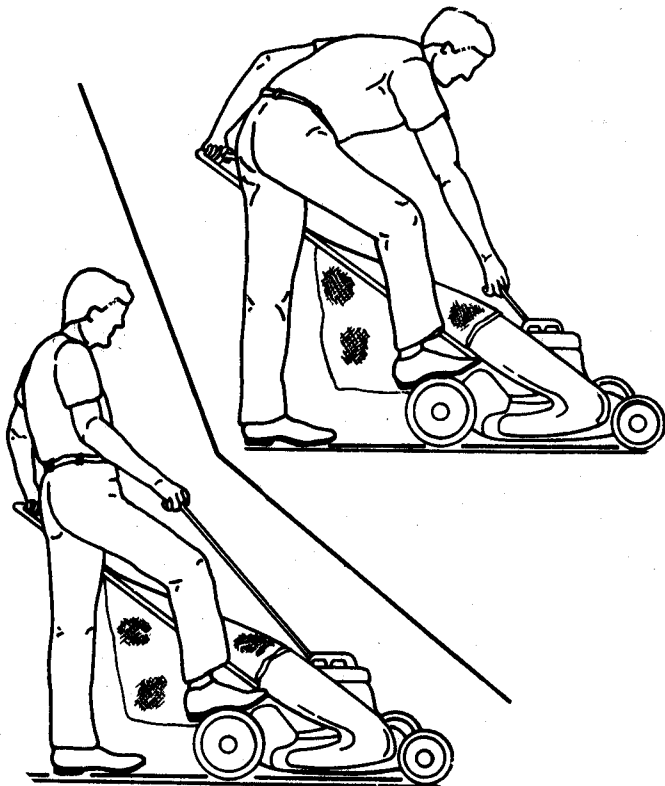

FIG 2 - MANUAL START PROCEDURE

PRE-START CHECKS

Before each start-up, check the following and/or perform the service specified as needed.

- CHECK guards, grass bag and adapter or side discharge chute to make sure these items are in proper position and securely tightened. NOTE: The tab on inside rear edge of the adapter or side chute must push the interlock spring in toward the center of the mower. If improperly installed, the engine cannot be started.

- CLEAN surfaces to remove dust, dirt, clippings particularly from cooling air intake screen on engine to prevent overheating.

- CHECK oil level in 4-cycle engine and add oil as needed to bring the level up to, but not over, full mark.*

- CHECK cutting height and adjust, as needed, to suit prevailing grass conditions before starting (Refer to height adjusting procedure on page 4).

- FILL FUEL TANK after pushing mower outdoors where fumes will be safely dissipated. On 2-cycle engine, use the correct fuel to oil ratio.*

*See engine manual for fuel & oil specifications.

STARTING-STOPPING ENGINE

Stop engine (& blade) by releasing the BLADE CONTROL or pulling the ENGINE CONTROL rearward to STOP position.

ROPE START: Since the engine cannot be started unless the BLADE CONTROL is held against the upper handle, use the following steps to rope start the engine. If the engine is cold, push primer button if so equipped. Also turn fuel valve on beforehand on engines so equipped.

1. Set ENGINE CONTROL in START or CHOKE position.
2. Place foot with toe pointing forward on top of rear tire.
3. Hold BLADE CONTROL firmly to handle.
4. Bend at waist to reach ROPE STARTER.
5. Pull rope as you straighten up to use your back more than arm muscles.
6. Repeat pulling until engine starts, guide rope slowly back to engine (the rope may break if allowed to snap back), continue holding Blade Control and move behind handles to operator's position.

ELECTRIC START: The keyswitch on electric start models has two positions which are RUN and START. The engine **cannot** be stopped at the keyswitch. Stopping is accomplished by either releasing the BLADE CONTROL or by moving the ENGINE CONTROL to STOP position. To start the engine electrically, proceed as follows: If the engine is cold, push primer button if so equipped. Also turn fuel valve on beforehand on engines so equipped.

1. Move ENGINE CONTROL to START or CHOKE position.
2. Hold BLADE CONTROL firmly to handle.
3. Insert key and turn KEYSWITCH to START position and hold until engine starts then release.

NOTE: To avoid depleting battery energy and/or overheating the starting motor, do not crank the engine continuously for more than 5 seconds at a time. Allow brief period between cranking attempts. If the battery charge is too low for cranking the engine, use the rope starter. The electric start engines have alternators to maintain sufficient battery charge when the mower is used frequently. See charging instructions on next page.

BATTERY CHARGING: A plug in battery charger is provided which operates off 120V/60hz household current. When recharging, disconnect battery from wiring harness, install charger in household outlet and connect battery to charger. If battery is weak charge for 48 hours. Charge battery for 72 hours if completely discharged.

Note: Continuous charging will not damage battery.

MOWING PROCEDURE

Vary speed to suit grass conditions. Set the engine speed high for tall, thick grass or lower for sparse grass. Push hand propelled models at a speed that is comfortable but will allow even cutting without stalling. On self propelled models, set ground SPEED CONTROL lever in desired forward speed setting, then grip the WHEEL DRIVE control and hold against handle to engage clutch for forward motion. Releasing the WHEEL DRIVE control stops forward motion. The mower can be hand pushed forward or in reverse for trimming with the WHEEL DRIVE control released. The ground speed can be changed to a new setting at any time when in motion. Use low speed setting and clutch for down-hill braking.

MOWING/VACUUMING HINTS: The cutting deck should be level under all conditions. As a general rule, never cut more than 1/3 off the height of the grass. If for example, the grass has grown to 4 inches tall, set the mower height latches in the lowest position which establishes the cutting height at approximately 3" (see cutting height chart) thereby cutting about 7/8" off the grass and staying well within the 1/3 off limit. If you want the grass shorter, wait a few days then recut to the lower height. If cut too short, the grass will expend more energy for development of new leaf structures and less for a healthy root system and will be more subject to burning. On the other hand, if allowed to grow too long, the lower portion will be shaded and, as a result will discolor. In dry periods, allow the grass to grow longer than you normally would. **NOTE:** Do not mow across an area where dry type fertilizer has just been spread as most of the fertilizer will be vacuumed up.

Change your mowing pattern from time to time for a smoother cut lawn. Finely chopped clippings add nutrients to the soil to promote grass growth, however if the clippings become too heavy, they mat to form thatch which prevents proper breathing and holds moisture. If thatch is particularly heavy, the Thatcherizer accessory described on the back page will do an effective job of dislodging the decaying matter. To prevent grass disease from thatch, vacuuming and bagging is recommended for most cuttings along with an occasional broadcasting of the clippings into the lawn for nutritive value. Your Snapper can be quickly converted back and forth from bagging to side discharge with the accessories.

EMPTYING GRASS CATCHER BAG

To install the KWIK-N-EZY grass catcher on the mower, slide the connector down over the adapter flange then lower the support frame hooks onto the middle handle (see figure 4). When the catcher becomes full, stop engine and lift the support hooks up over the handle then lift the connector off and continue lifting while moving the catcher forward until the bag clears the mower. To empty the bag, raise the connector end up and release the handle of the door flap. Shake the catcher back and forth to dump the clippings.

TO EMPTY IN TRASH BAG: Use the following procedure to empty clippings in trash bag. After removing catcher from mower, place connector end on ground, open door flap, slip trash bag over the catcher, turn catcher over so that large opening is down inside bag, lift catcher by connector and door handles and shake until clippings are dumped in the trash bag.

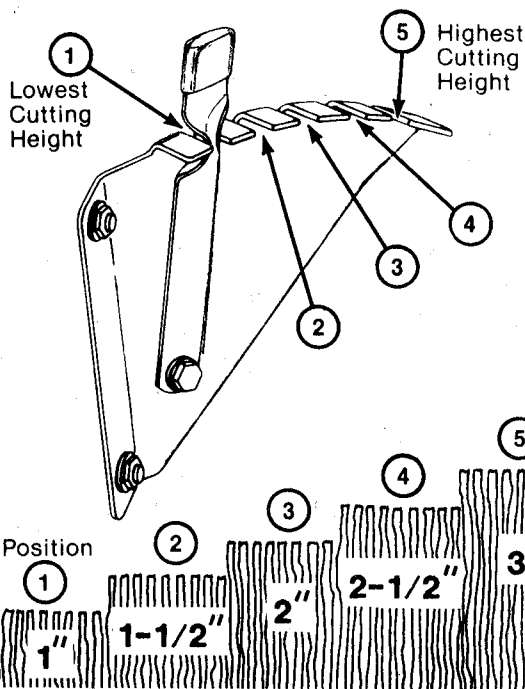

FIG. 3 - CUTTING HEIGHT SETTINGS

CUTTING HEIGHT ADJUSTMENT

Always stop the engine and wait until the mower blade comes to a complete halt before readjusting the cutting height! To readjust, move the height adjusting latch on each wheel outward and slide each, one notch at a time, to the position desired. Positioning the latches in the highest notch sets the mower at the lowest cutting height while the lowest notches sets it in the highest cutting position. Refer to figure 3 for the approximate cutting height afforded by each of the five latch positions. For best results, set both latches on one side first, then go to the other side and set these latches into corresponding notches. Before resetting the rear latches into lower notches, lift the weight of mower off the rear wheels first by pulling up on the handle, then reset.



FIG. 4 - REMOVING GRASS CATCHER

SERVICE PROCEDURE

The mower itself requires very little service, however, it is important that the engine be serviced at the intervals specified in the engine manual furnished with your mower. When performing any services on the mower, always disconnect the spark plug wire from the spark plug to prevent unintentional starting. When tipping the mower to work on the underside, always tilt with spark plug up to prevent flooding the engine with gasoline and oil which would cause hard starting after servicing. NOTE: On Tecumseh powered units, comply with the following rules to prevent oil from entering the air cleaner and ruining the dry element (1) **DO NOT** keep engine in tilted position for more than 5 minutes. (2) **DO NOT** crank engine or turn blade while tilted (3) **DO NOT** tilt plug up more than 90 degrees.

To retain the quality of your mower, use Genuine Snapper Replacement Parts only. To obtain the correct part for your particular mower, always specify model and serial number as found on nameplate. Contact your local Snapper Dealer for parts and service assistance. We recommend returning your mower to an authorized Snapper Dealer on a yearly basis for inspection and addition of any new devices which might upgrade the safety of your mower. For the nearest Snapper Dealer, check the yellow pages under the heading LAWN MOWERS.

LUBRICATION SERVICES

ENGINE - Change oil every 25 hours as specified in engine manual.

TRANSMISSION (Self-Propelled Models) - Remove plug and check every 25 hours of operation. If grease is not visible on the input gear, add small amount of Snapper "OO" grease, CAUTION: Avoid over lubricating - capacity not to exceed 2 ounces of grease. Snapper "OO" grease is available in a convenient quart size container (Part No. 1-1050) at your Snapper dealer. Replace plug after servicing transmission.

MOVING PARTS - Occasionally put a few drops of oil on movable surfaces of components such as the height adjusting levers, wheel axles, shift levers, etc. Be careful not to spill oil on surface of drive disc on self-propelled models.

CUTTING BLADE SERVICE

CAUTION: Before checking or doing any work on the blade, disconnect the spark plug wire and secure it away from the plug to prevent unintentional starting.

CHECK at frequent intervals to make sure the blade is securely tightened and that it is in good condition.

REPLACE blade if badly chipped, bent, out of balance or as soon as a notch starts wearing in the tip between the flat surface and upturned lift as depicted in View B, Figure 6. This type wear pattern occurs more rapidly under sandy soil conditions. **CAUTION:** Never operate the mower with blade worn to the extent shown in View C as the tip could fly off causing personal injury or property damage.

SHARPEN blade when the cutting edges become dull if the blade is in otherwise good condition. Sharpen blade on a grinding wheel at a angle of 22 to 28 degrees. The cutting surface should extend in about 3 1/2" from the tips. Check the blade after sharpening to determine that it is still balanced. It will cause excessive vibration if unbalanced. **BE CAREFUL: AVOID CUTTING YOURSELF ON SHARP BLADE!** Protect your hands from cuts while handling blade

INSTALL blade with components in sequence shown in Figure 7. Make sure that the turned-up rims in the center of the blade fit over the edges of the blade drive hub when installing. Do not substitute any components here. Tighten the blade retaining capscrew 20 to 30 foot pounds torque value.

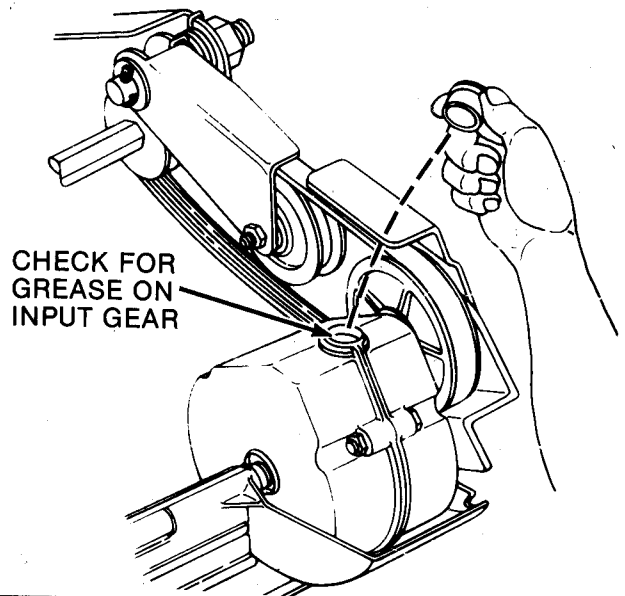

FIG. 5 - CHECKING TRANSMISSION

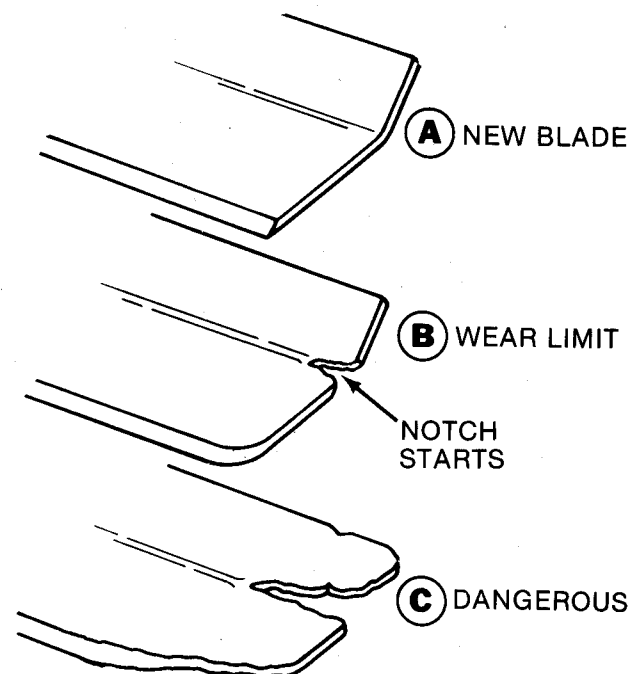

FIG 6 - BLADE WEAR PATTERNS

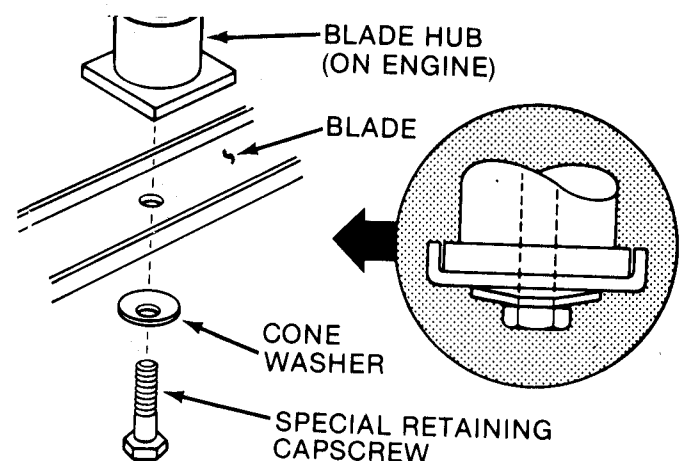

FIG 7 - BLADE RETENTION DETAIL

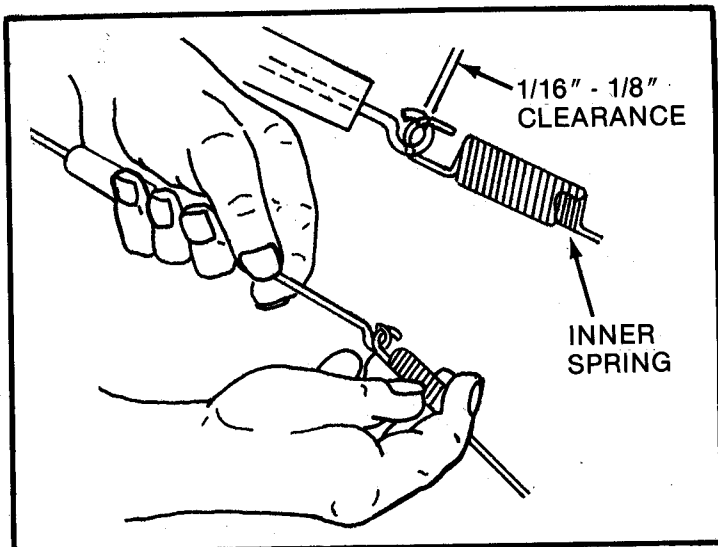

FIG 8 - CLUTCH LINKAGE ADJUSTMENT

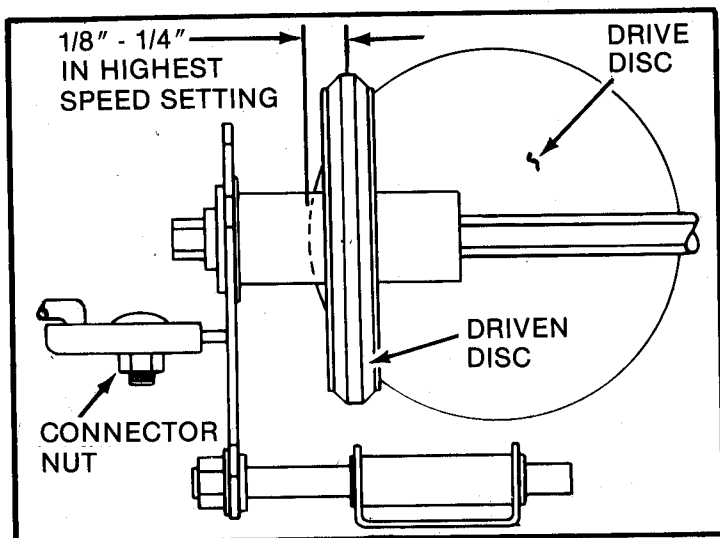

FIG 9 - DRIVEN DISC COMPONENTS

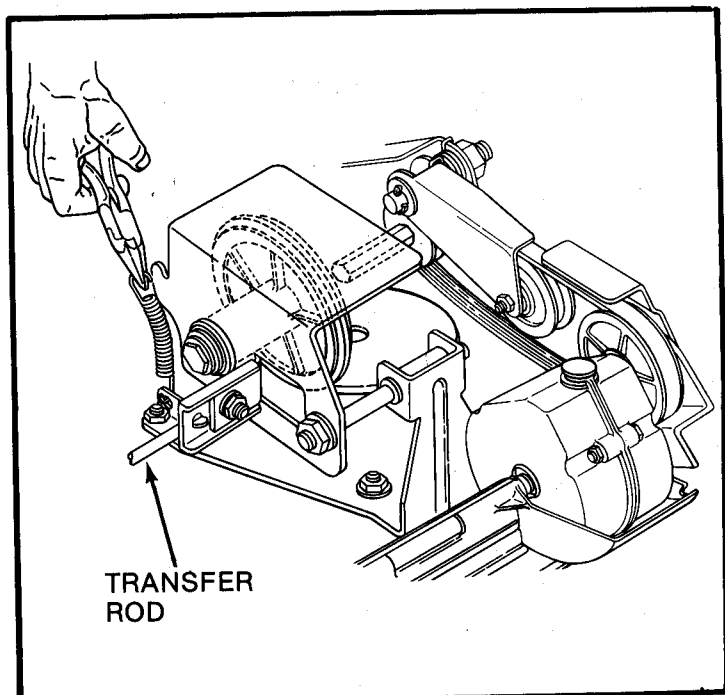

FIG 10 - UNHOOKING DRIVE SPRING

CLUTCH LINKAGE (Self-Propelled)

Make sure the vinyl cover remains over the spring(s) connecting the clutch pull rod to the clutch idler components (see Figure 8). This not only keeps the spring clean but prevents it from rubbing against and wearing a hole in the grass bag on mowers so equipped.

ADJUSTMENTS: If excessive pressure is required to hold the wheel drive clutch lever in the engaged or drive position, the clutch pull rod springs are probably out of adjustment. This is checked with the engine stopped and the clutch handle released. When properly adjusted there should be 1/16" to 1/8" clearance between the inside hook of the spring and inside eye of the push rod as shown in Figure 8. To adjust, unhook and rotate the inner and outer springs in opposite direction, rehook and check clearance. Repeat this procedure until the clearance is correct. If the wheel drive control does not snap back to disengage the drive when the handle is released, check the clip holding the pull rod to the handle bar for binding. Position this clip about 5" from the upper handle and rotate to best position to allow the rod to slide without interference.

DRIVEN DISC SERVICE

If the mower does not pull properly with the wheel drive clutch engaged, check for the following: Grease on drive disc causing slippage, broken or disconnected driven assembly spring (see Figure 10), driven disc too worn to contact the drive disc properly, driven disc out of adjustment. This condition could also be caused by worn belts. If the belts are in good condition and the clutch is properly adjusted, service the drive system as follows:

DRIVEN DISC ADJUSTMENT: With the engine stopped and the speed lever shifted into highest speed setting, the driven disc should be 1/8" to 1/4" from the center of the drive disc as illustrated in Figure 9. Readjust with engine stopped as follows: Shift the speed selector into the highest speed setting, loosen the connector hex nut and slide the driven disc assembly inward or outward until the center is 1/8" to 1/4" from the edge of the drive disc. Retighten connector nut to lock at new setting.

DRIVEN DISC REPLACEMENT: If the rubber of driven disc is badly chunked or worn down to within 1/16" of the metal rim, remove the driven disc assembly and replace the driven disc as follows: Remove the clip and detach the transfer rod from the speed control lever (Figure 10). Using a pair of needle nose pliers, unhook the drive spring and slide the driven disc assembly off as shown in Figure 11. Remove the five machine screws securing the rubber driven disc and separate the worn disc from the hub. Reverse this procedure to install the replacement disc and to reconnect the drive components.

BEARING REPLACEMENT: If the bearing fails, remove the driven disc assembly as described above and replace the bearing as follows: Remove the snap ring using special snap ring pliers. Slide the driven ring, hub and bushing out of the bearing. Remove the four screws and bearing. Reverse this procedure to install the replacement bearing and reconnect the drive components.

BELT SERVICE

Slippage of worn belts will cause self-propelled models to pull poorly. On these the engine belt transmits this power to the poly-V-belt which, in turn, engages the clutch to drive the transmission and rear drive wheels.

ENGINE BELT REPLACEMENT: Disconnect the spark plug wire and empty the fuel tank or tape the vents in the filler cap to prevent fuel spillage then proceed as follows: Unhook the idler arm spring from the right rear wheel bracket and remove the driven disc assembly as described under DRIVEN DISC service. Tilt the mower up on its right wheels and remove the cutting blade and hub, then remove the drive disc retaining nut and internal tooth lockwasher. Lift the drive disc-idler assembly off the deck and remove faulty belt. Loop end of replacement belt over engine drive

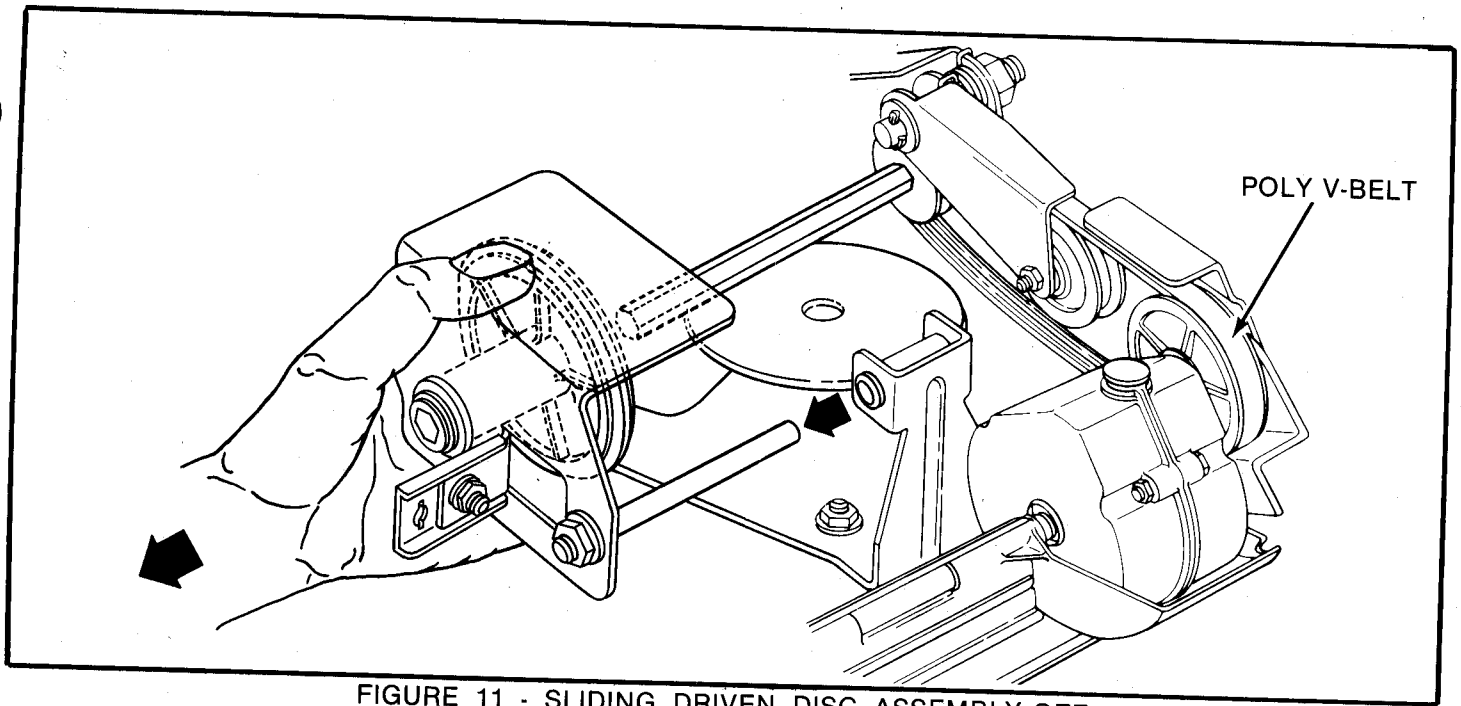

FIGURE 11 - SLIDING DRIVEN DISC ASSEMBLY OFF

pulley and insert other end through deck opening. Loop belt around driven pulley then push the drive disc-idler assembly down into position on the deck. Install the internal tooth lockwasher and disc retaining nut on the drive disc stud and securely tighten these. Test to make sure the idler arm is free to pivot without interference then reinstall the cutting blade components (refer to **BLADE SERVICE**), driven disc assembly, then using a stiff wire (Hint: coat hanger) with hooked end, pull the hooked end of the idler arm spring through the larger hole in the right wheel bracket and hook the end through the smaller hole.

POLY V-BELT REPLACEMENT: This belt can be replaced after removing the driven disc assembly as described earlier. Note the arrangement of old belt around pulleys before cutting and removing it. Slip the replacement belt over the end of hex shaft pulley and work over idler pulley. Twist the belt sideways and pull it upward between the differential bracket and transmission pulley. Slip belt over grooves in the hex shaft, clutch idler and transmission pulleys. **Note:** When properly installed, the lower span of the Poly V-Belt will be **above** the belt guide.

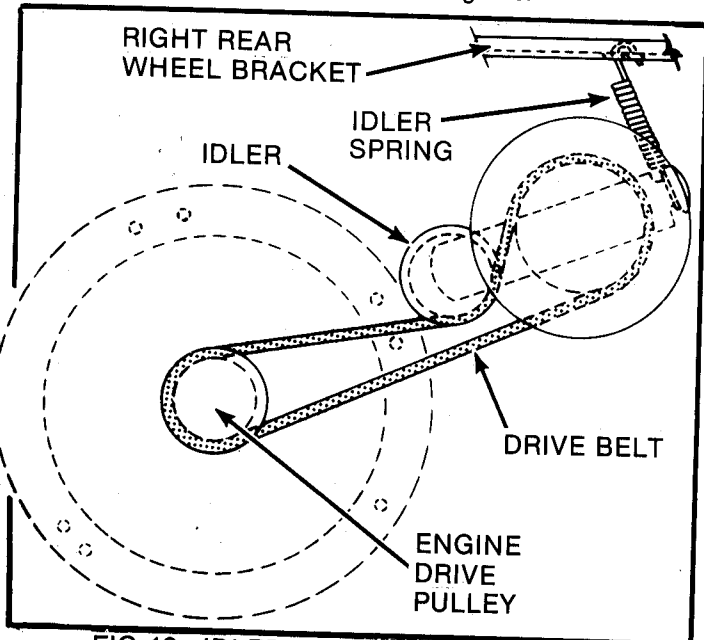

FIG 12 - IDLER & ENGINE BELT DETAIL

STORAGE PROCEDURE

Prepare your mower for storage at the end of the mowing season as follows. (Refer to the engine manual for directions for preserving engine). With the spark plug wire disconnected, turn the mower on its side and thoroughly clean underside of deck. Scrape away grass with putty knife and/or wire brush then wash down with water from a hose. **WARNING:** Tape openings closed to prevent spraying water into exhaust or air intake while washing. Clean external surfaces of mower and allow to dry, then lubricate all exposed metal with a light coating of oil to prevent corrosion. Make sure grass bag is completely emptied to prevent decay and formation of mold while in storage. The grass bag may be washed in detergent but allow it to dry thoroughly. Store mower during off season in a storage shed or dry area protected from weather. Handles on push models can be tilted forward for storage by loosening wingnuts--do not kink cables!

HANDLE HEIGHT ADJUSTMENT

To raise or lower handle, loosen the adjusting locknuts on both sides as shown below, reset handle to desired position and retighten the locknuts.

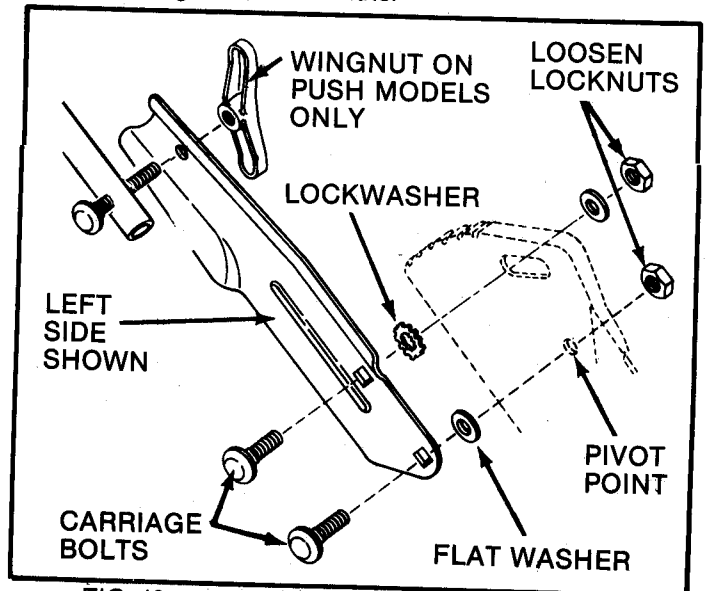

FIG. 13 - HANDLE HEIGHT ADJUSTMENT

SNAPPER 21" HI-VAC WALK MOWERS

POPULAR ACCESSORIES

Depending on how your mower is originally equipped, it can be converted to perform other lawn care duties with the kits described below.

SNAPPERIZER KIT: Converts mower into an outdoor vacuum and shredder to broadcast shredded clippings and leaves with side discharge chute or for bagging with the grass catcher. Specify model mower when ordering.

SNAPPERIZER
KIT #6-0440

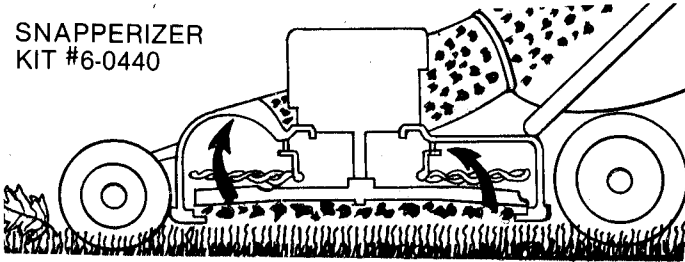

GRASS CATCHER BAG KIT: If your mower is equipped with side discharge chute, it can be converted for bagging operation whenever desired with a grass bag kit. Specify model when ordering.

SIDE CHUTE KIT: If your mower is equipped with the grass catcher, it can be quickly converted to side discharge with a side chute kit to broadcast clippings and eliminate bagging whenever desired, and to quickly convert back to bagging operation. Specify model when ordering.

MULCHERIZER
KIT #6-0420

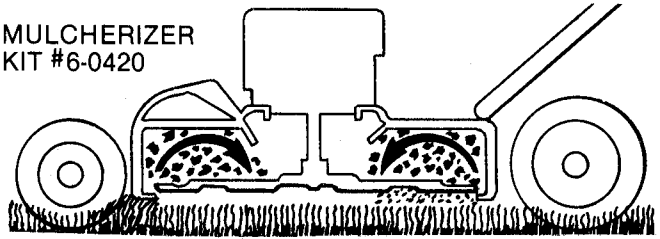

MULCHERIZER KIT: Converts mower into effective mower/mulcher to cut and chop the grass before blowing clippings directly into the lawn as nutritive mulch. Specify model when ordering.

THATCHERIZER KIT: Attaches to front of self-propelled models to dislodge thatch for vacuuming into grass catcher. One kit fits all 21" models.

THATCHERIZER
KIT #6-0476

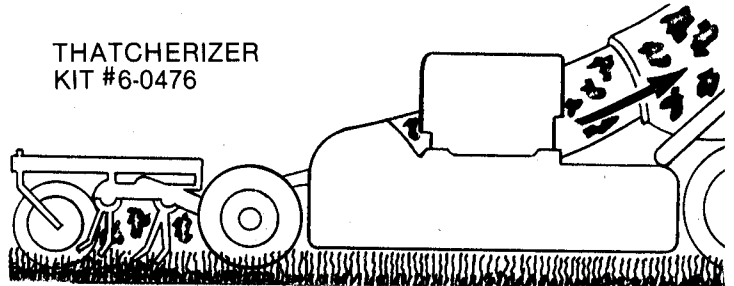

MANUFACTURER'S 2 YEAR LIMITED WARRANTY

For two (2) Years from purchase date for the original purchaser's residential, non-commercial use [ninety (90) days from purchase date for the original purchaser's commercial, rental, or other non-residential use], SNAPPER POWER EQUIPMENT, through any SNAPPER dealer will replace, free of charge, any part or parts found upon examination by the factory at McDonough, Georgia, to be defective in material or workmanship or both.

All transportation cost incurred by the purchaser in submitting material to a SNAPPER dealer for replacement under this warranty must be borne by the purchaser.

This warranty does not apply to engines and their components, as these items are warranted separately by their manufacturers, and does not apply to batteries which are covered separately. This warranty does not apply to parts that have been damaged by accident, alteration, abuse, improper lubrication, normal wear, or other cause beyond our control.

There is no other express warranty.

Implied warranties, including those of merchantability and fitness for a particular purpose, are limited to two (2) years from purchase date for the original purchaser's residential, non-commercial use [ninety (90) days from purchase for the original purchaser's commercial, rental or other non-residential use], and to the extent permitted by law any and all implied warranties are excluded. This is the exclusive remedy. Liabilities for consequential damages, under any and all warranties are excluded.

Some states do not allow limitations on how long an implied warranty lasts, or do not allow the exclusion or limitation of incidental or consequential damages, so the above limitation or exclusion may not apply to you.

This warranty gives you specific legal rights, and you may also have other rights which vary from state to state.

WARNING: THE USE OF REPLACEMENT PARTS OTHER THAN GENUINE SNAPPER PARTS MAY IMPAIR THE SAFETY OF SNAPPER PRODUCTS AND WILL VOID ANY LIABILITY AND WARRANTY BY SNAPPER ASSOCIATED WITH THE USE OF SUCH PARTS.

IMPORTANT: Please fill out the attached SNAPPER Product Registration Card immediately and mail to:

SNAPPER POWER EQUIPMENT

McDonough, Georgia 30253