

PARTS MANUAL FOR

SNAPPER®

21" SERIES 8* BLADE BRAKE CLUTCH WALK BEHIND MOWERS

*NOTE: THE SERIES NUMBER IS THE
LAST NUMBER IN THE FIVE DIGIT
MODEL DESIGNATION.



<u>INDEX-GROUP</u>	<u>(SECTION)</u>	<u>PAGE(S)</u>
HANDLES, CONTROLS	(ONE)	1.1-1.3
ENGINE SPECIFICATIONS	(ONE)	1.3
SIDE CHUTES, ADAPTERS	(TWO)	2.1
CUTTING DECK, BLADES	(THREE)	3.1-3.2
DRIVE SYSTEM-(SELF PROPELLED)	(FOUR)	4.1-4.4
WHEELS, BRACKETS, LATCHES	(FIVE)	5.1-5.4
ACCESSORIES	(SIX)	6.1-6.4
GRASS CATCHER	(SIX)	6.1-6.2
DECALS	(SIX)	6.2

SNAPPER POWER EQUIPMENT

McDonough, GA., 30253 U.S.A.



(Rev. 1, 6/96)

MANUAL #06133

HANDLES & CONTROLS

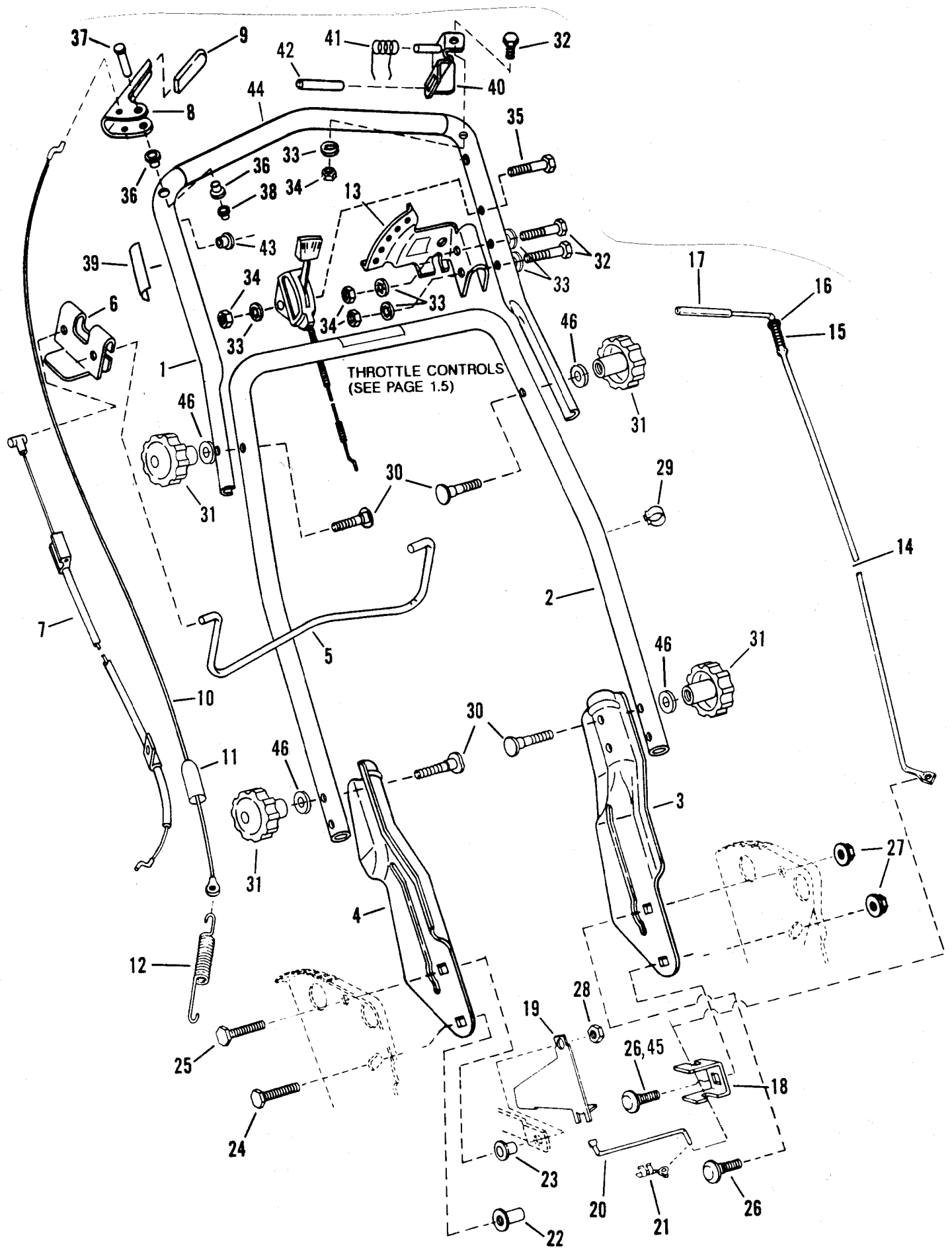

ITEM	PART NO.	DESCRIPTION
1	3-3445	HANDLE, Upper
2	3-6350	HANDLE, Middle
3	3-8467	HANDLE, Lower Left Hand
4	3-8466	HANDLE, Lower Right Hand
5	1-9762	CONTROL, Blade
6	3-2445	CLIP, Blade Control
7	1-9255	CABLE, Blade Control
8	3-2826	HANDLE, Wheel Drive
9	1-4307	GRIP, Wheel Drive Handle
10	2-3134	CABLE, Clutch Pull (Z-BEND)
11	1-2121	COVER, Vinyl
12	1-2122	SPRING, Clutch
13	3-8478	SECTOR, Speed
14	2-3795	LEVER, Speed Control
15	1-2093	SPRING, Speed Control
16	9-0188	WASHER, 3/8 Flat
17	2-3801	GRIP, Speed Control Handle
18	3-2830	ANCHOR, Speed Control
19	3-2408	GUIDE, Lower V-Belt
20	2-3790	ROD, Transfer
--	5-1698	ASSEMBLY, Transfer Rod (Euro) (Not Shown)
21	1-0937	CLIP, Transfer Rod
22	9-0895	TEE-NUT, 5/16-18
23	1-2114	BUSHING, Differential
24	9-0595	BOLT, 5/16-18x3/4 Flange Lock
25	9-0238	CAPSCREW, 5/16-24x1
26	9-1026	BOLT, 5/16-18x5/8 Carriage
27	9-0585	NUT, 5/16-18 Hex Flange Lock
28	9-0222	NUT, 5/16-24 Center Lock
29	2-3813	CLIP, Cable/Wiring
30	9-1013	SCREW, 5/16-18x1-7/8 Curved Head
31	2-3735	KNOB, 5/16-18
32	9-1025	CAPSCREW, 1/4-28x1-3/8
33	9-1023	LOCKWASHER, 1/4 Internal Tooth
34	9-1024	NUT, 1/4-20 Hex
35	9-1022	CAPSCREW, 1/4-28x1-3/4
36	1-4343	BUSHING
37	2-3792	PIN, Clutch Handle
38	9-1020	PUSH-NUT (for handle pin)
39	2-4089	DECAL, Blade Control (R.H. Side)
39	2-3886	DECAL, Wheel Control (Euro)(R.H. Side)
--	2-3893	DECAL, Blade Control (on mid handle)
40	5-1904	ASSEMBLY, Blade Control Bracket
41	1-5108	SPRING, Blade Control
42	1-4946	GRIP, Pivot
43	1-5092	BUSHING
44	2-2460	GRIP, Foam
45	2-4087	DECAL, Speed Sector
--	2-4446	DECAL, Speed Selector (Euro)
46	9-1068	LOCKWASHER, 5/16 Internal Tooth

THROTTLE CONTROLS

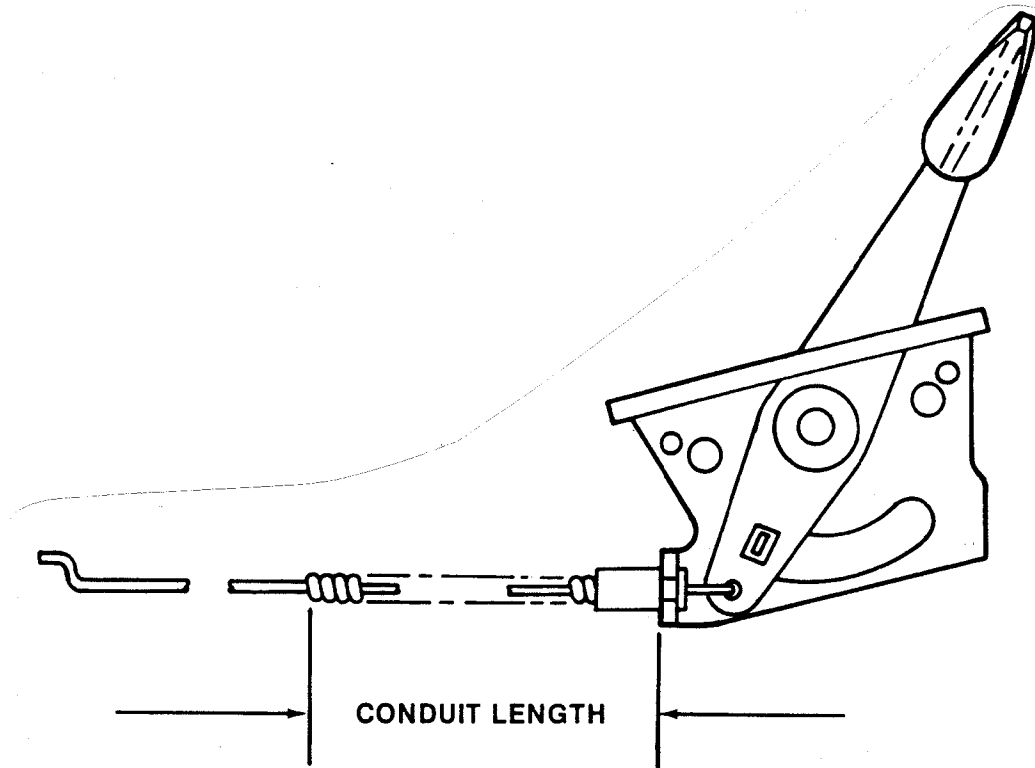

1992 MODELS

ENGINE/MODEL	(CYCLE)	PART NO.	CONDUIT LENGTH
BRIGGS	(4)	2-4476	58-1/4"

ENGINE SPECIFICATIONS

ENG. H.P.	START TYPE	SNAPPER #	ENG. MFGR.	MFGR. MODEL	MFGR. TYPE
5.5	ROPE	2-2737	BRIGGS	99772	0110-01
5.0	ROPE	2-2536	BRIGGS	124802	0210-01

NOTE: PURCHASE ENGINE PARTS FROM ENGINE MANUFACTURER'S DEALER.

SIDE CHUTE, ADAPTER

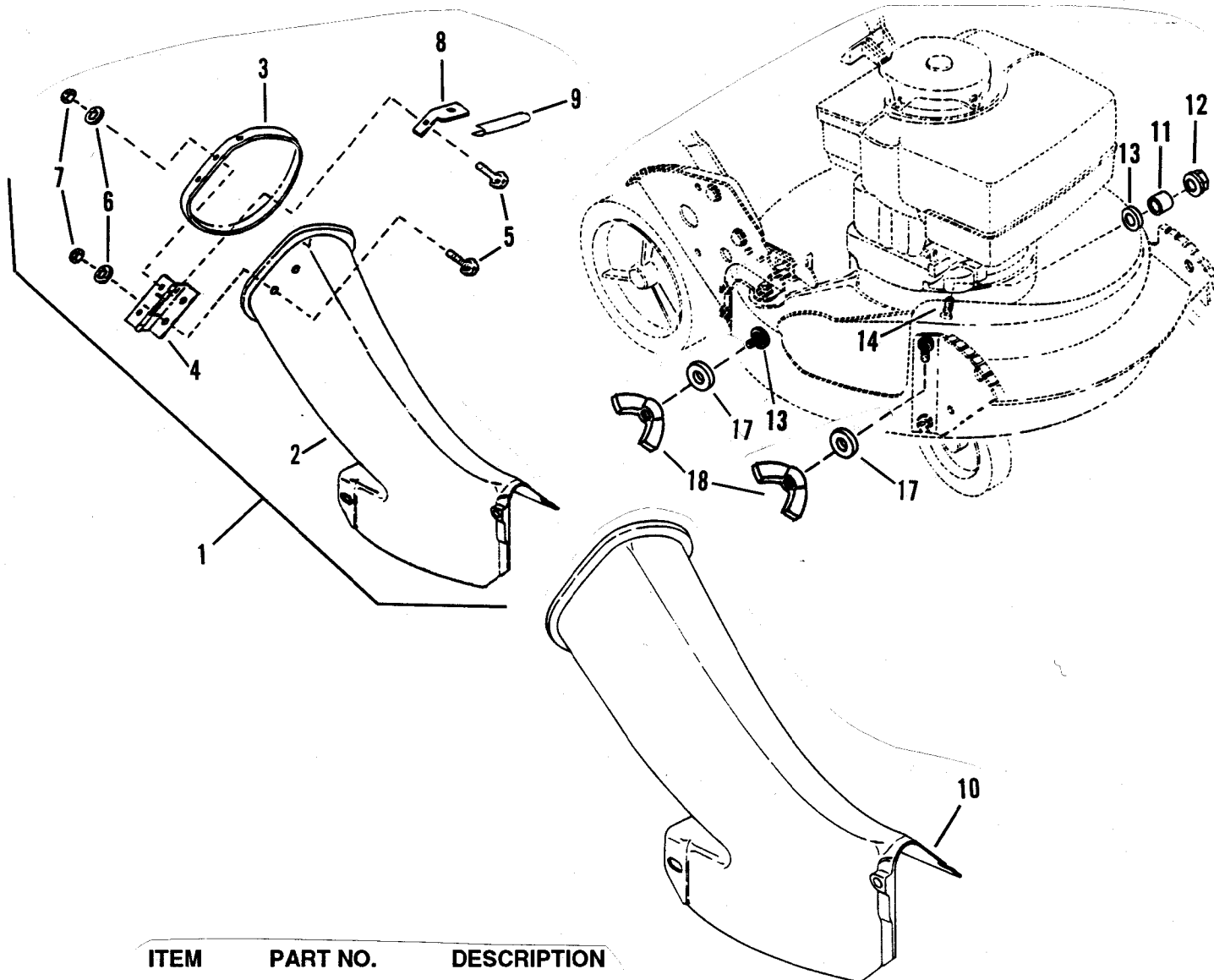

ITEM	PART NO.	DESCRIPTION
1	5-1951	ASSEMBLY, Bag Adapter & Cover (European Models Only) (Includes Items 2 Thru 9)
2	1-6107	ADAPTER, Grass Bag
3	1-9287	COVER, Bag Adapter
4	2-3000	HINGE, Chute Cover
5	9-0005	BOLT, 1/4-20 x 1/2" Short Neck Carriage (5)
6	9-1023	WASHER, 1/4 Internal Tooth Lock (5)
7	9-0063	NUT, 1/4-20 Hex (5)
8	3-2661	STOP, Cover
9	2-3042	MOLDING, Trim
10	1-6050	ADAPTER, Grass Bag
11	2-4340	SPACER
12	9-0951	NUT, 5/16-18 Hex Flange
13	1-1791	RETAINER, 5/16 Bolt
14	9-0001	BOLT, 5/16-18 x 3/4 Short Neck Carriage
15	6-0955	KIT, Side Chute
16	1-6090	CHUTE, Side
17	9-1076	WASHER, 5/16 Flat
18	2-4085	WING NUT, 5/16-18

PAC-N-SAC components found in separate manual #06121.

CUTTING DECK, BLADE, INTERLOCK

REAR WHEEL BRACKETS
See Pages 5.1-5.2.

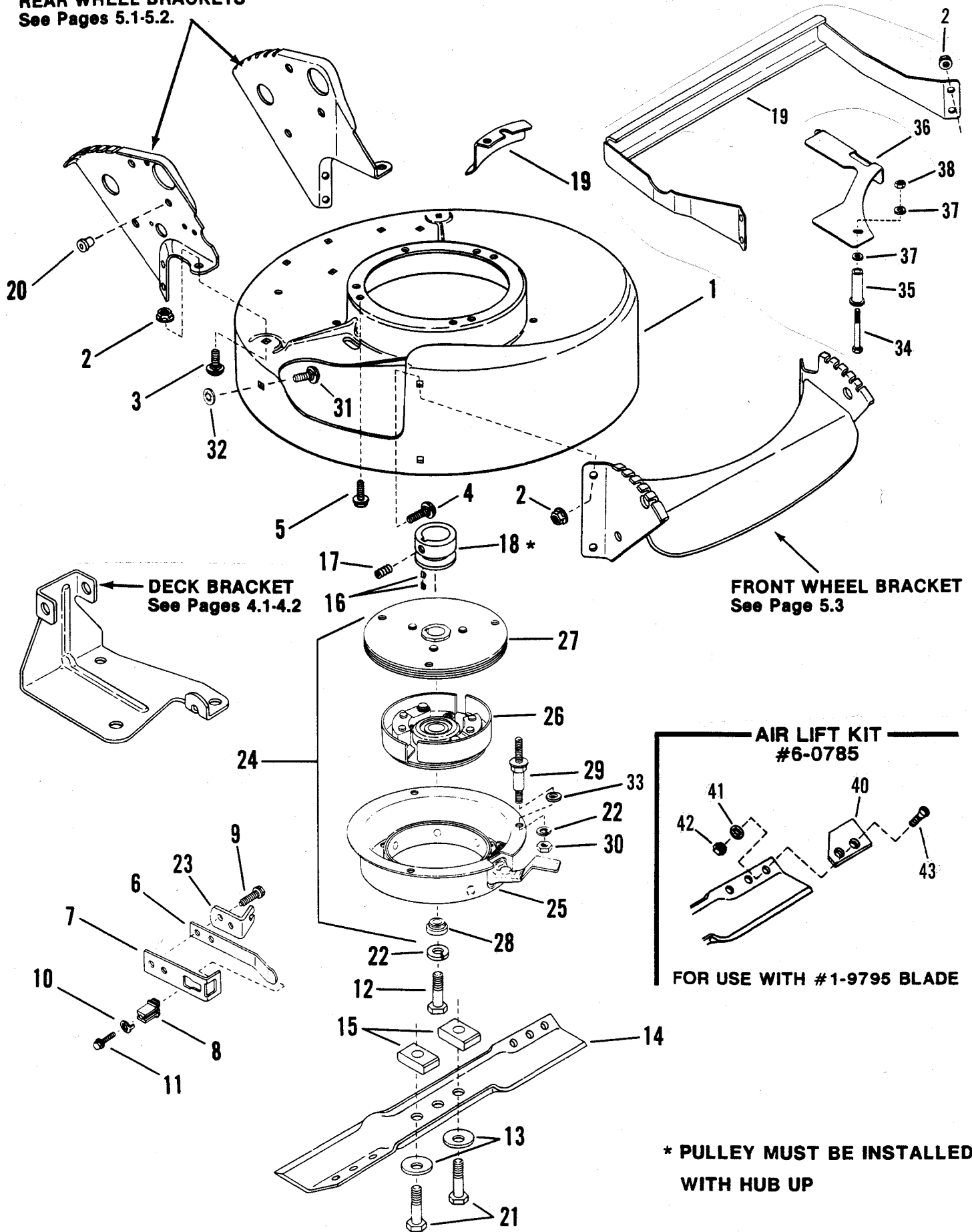

CUTTING DECK, BLADE, INTERLOCK

ITEM	PART NO.	DESCRIPTION
1	5-1598	DECK, Mower (Includes painted Deck)
2	9-0585	NUT, Hex Flanged Lock (10)
3	9-0731	BOLT, 5/16-18 x 1/2" Short Neck Carriage Gr. 5 (9)
4	9-1169	BOLT, Bolt 5/16-18 x 1-1/8" Short Neck Carriage
5	9-0324	SCREW, 3/8-16X1" Self-tapping (Engine Mounting)(3)
6	3-2417	SPRING, Wheel Bracket Type Interlock
7	3-2416	BRACKET, Wheel Bracket Type Interlock
8	1-2048	INSULATOR, Interlock
9	9-0539	SCREW, 1/4-20x1/2" Hex Self-tapping (2)
10	9-0385	WASHER, No. 8 Tab Int. Tooth Lock
11	9-0379	SCREW, #8-18 x 3/4" Hex Head Machine
12	9-0167	SCREW, 3/8-24 x 2.0" Hex Head Cap
13	1-2063	WASHER, Cone (2)
14	1-9795	BLADE, Cutter
15	3-2175	SPACER, Blade (2)
16	1-0783	KEY, Hi-Pro
--	1-5894	KEY, Woodruff
17	9-0201	SCREW, 5/16-18 x 5/16" Hex Socket Set
18	1-5780	PULLEY, Engine (25mm I.D. x 2-1/8" O.D.)
19	4-9755	STRUCTURE, Fender (Euro)
20	1-2135	BUSHING, Interlock Wire
21	9-0503	SCREW, 3/8-16 x 1-3/4" Hex Head Cap (2)
22	9-0118	LOCKWASHER, 3/8 Split
23	3-2421	BRACKET, CABLE-BBC
24	5-2818	ASSEMBLY, Blade Clutch (Includes items 25 thru 28)
25	1-6582	ASSEMBLY, Bowl & Brake
26	1-4178	ASSEMBLY, Clutch Bearing
27	2-4349	ASSEMBLY, Flywheel
28	1-4176	WASHER, Blade
29	1-5095	STAND-OFF (3)
30	9-0613	NUT, 3/8-16 Hex Flange Lock (3)
31	9-0799	BOLT, 5/16-18 x 1" Short Neck Carriage (3)
32	1-1791	RETAINER, 5/16 Bolt (3)
33	1-2316	WASHER, 3/8 Flat (3)
34	9-0702	BOLT, 5/16-18 x 2-1/4" Hex Flange Lock
35	1-3320	BUSHING
36	3-6240	COVER, Belt (European Only)
37	9-0187	LOCKWASHER, 5/16 Split (3)
38	9-0196	NUT, 5/16-18 Hex (2)
39	9-0534	SCREW, 5/16-18 x 1/2" Hex Head Cap
-	6-0785	KIT, Air Lift. (Includes items 40 thru 43)
40	3-2558	LIFT, Air (2)
41	9-0391	WASHER, 5/16 Internal Tooth Lock (4)
42	9-0223	NUT, 5/16-24 Hex (4)
43	9-0228	SCREW, 5/16-24 x 21/32" Machine (4)

DRIVE SYSTEM SELF-PROPELLED

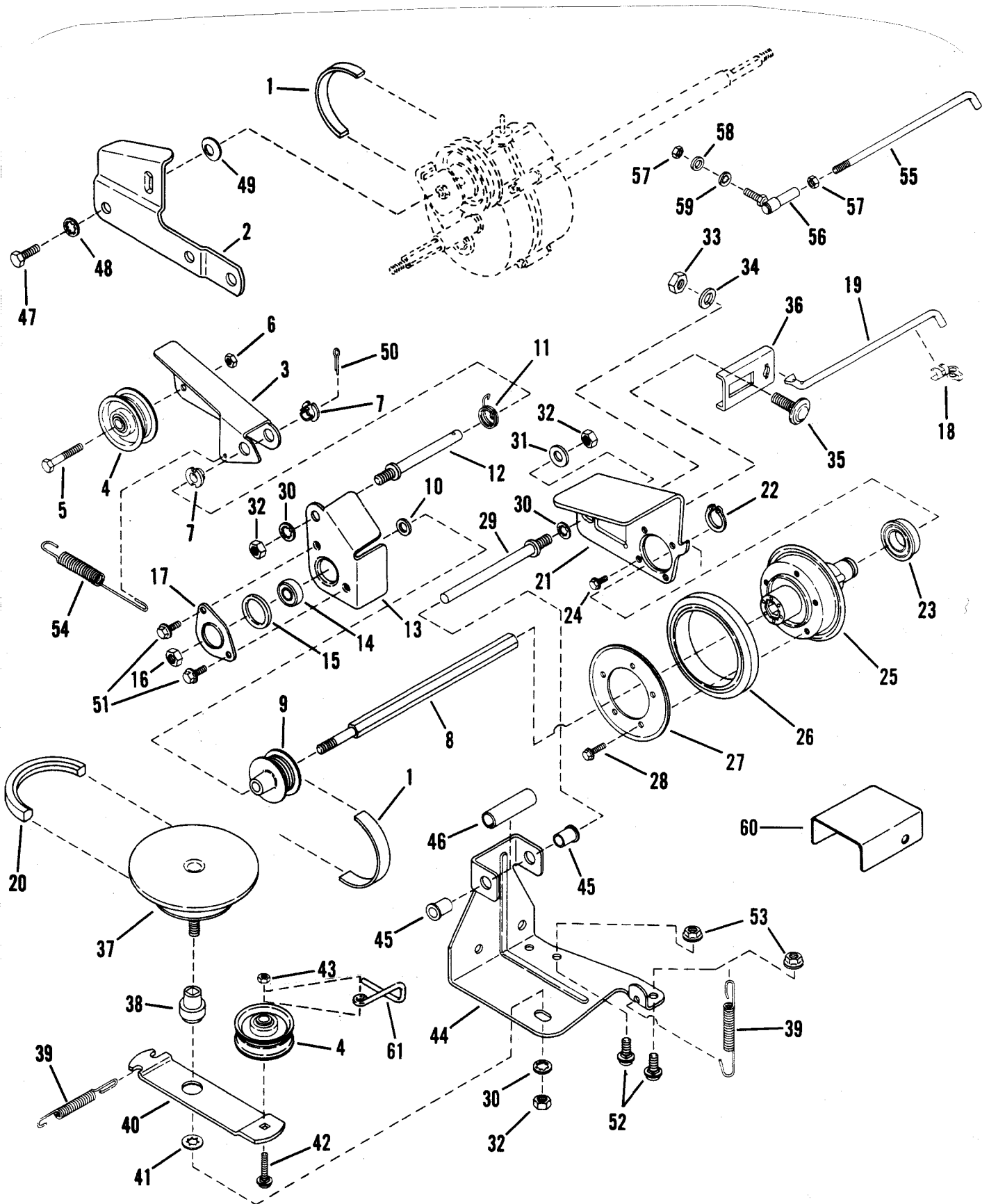

ITEM	PART NO.	DESCRIPTION
1	1-2354	BELT, Poly-Vee
2	3-1880	LINK, Differential
-	5-1921	ASSEMBLY, Clutch Idler (Includes items 3 thru 7)
3	3-2832	ARM, Clutch Idler
4	1-2124	PULLEY, Idler (2)
5	9-0552	SCREW, 1/4-28x1-3/8" Hex Head Cap
6	9-0303	NUT, 1/4-28 Hex Lock
7	1-2117	BUSHING, 3/8 I.D. Nylon (2)
8	2-3744	SHAFT, Hex
9	1-9383	PULLEY, Poly-V
10	1-2316	WASHER, 3/8 Flat
11	1-2126	SPRING, Torsion
12	1-2111	STUD
13	3-1873	HOLDER, Bearing (Inner Half)
14	1-2304	BEARING, Ball
15	1-1025	O-RING
16	9-0289	NUT, 3/8-24 Hex Center Lock
17	3-1809	HOLDER, Bearing (Outer Half)
18	1-0937	CLIP, 1/4 Right Arc (Transfer Rod)
19	2-3790	ROD, Transfer (Standard Models)
20	1-2508	BELT, Engine Drive
--	5-7444	ASSEMBLY, Driven Disc (Includes items 21 thru 28)
21	3-8486	PLATE, Thrust
22	1-0746	RING, Retaining
23	1-5474	BEARING, Ball
24	9-0981	SCREW, #10-32x1/4" Self-Tapping Machine (4)
25	5-1616	ASSEMBLY, Hub (Includes 1-1108 Bushing & Two 9-0913 Screws)
26	2-3364	RING, Driven
27	3-1013	PLATE, Ring Retaining
28	9-0913	SCREW, #10-24x1/2" Self-Tapping Machine (5)
29	1-2125	GUIDE, Thrust Plate
30	9-0390	WASHER, 3/8 Internal Tooth Lock (3)
31	9-0122	WASHER, 3/8 Flat
32	9-0155	NUT, 3/8-24 Hex (3)
33	9-0196	NUT, 5/16-18 Hex (Standard Models)
34	9-0187	WASHER, 5/16 Split Lock (Standard Models)
35	9-1097	BOLT, 5/16-18x3/4" Carriage (Standard Models)
36	3-2831	CONNECTOR, Transfer Rod (Standard Models)
37	*	ASSEMBLY, Drive Disc
38	*	BUSHING
39	1-7326	SPRING (Wheel Drive & Idler) (2)
40	3-2116	ARM, Idler
41	1-3847	RETAINER, 3/8 Bolt
42	9-0947	BOLT, 1/4-20x1-1/2" Carriage
43	9-0372	NUT, 1/4-20 Hex Center Lock
-	5-0751	ASSEMBLY, Deck Bracket (Includes items 44 thru 46)
44	3-1919	BRACKET, Deck
45	1-2306	BUSHING, Flange (2)
46	2-1758	SPACER
47	9-0534	SCREW, 5/16-18x1/2" Hex Head Cap
48	9-0391	WASHER, 5/16 Internal Tooth Lock
49	1-1079	WASHER, Spring
50	9-0555	PIN, 3/32x1/2" Cotter
51	9-0539	SCREW, 1/4-20x1/2" Self-Tapping
52	9-0731	BOLT, 5/16-18x5/8" Short neck Carriage (2)
53	9-0585	NUT, 5/16-18x5/8" Hex Flange Nut
54	1-2122	SPRING, Clutch
**55	1-5752	LINK, Transfer
**56	1-5753	JOINT, Ball (Commercial Models)
**57	9-0095	NUT, 1/4-28 Hex (Commercial Models)
**58	9-0055	WASHER, 1/4 Flat (Commercial Models)
**59	9-0053	WASHER, 1/4 Internal Tooth Lock (Commercial Models)
**60	3-2664	SHIELD, Hex Shaft
61	1-6380	SCRAPER, Drive Pulley

****NOTE: Used on European Models Only.**
***NOTE: Order Kit #6-0710 for Replacement**

TRANSMISSION (DIFFERENTIAL)

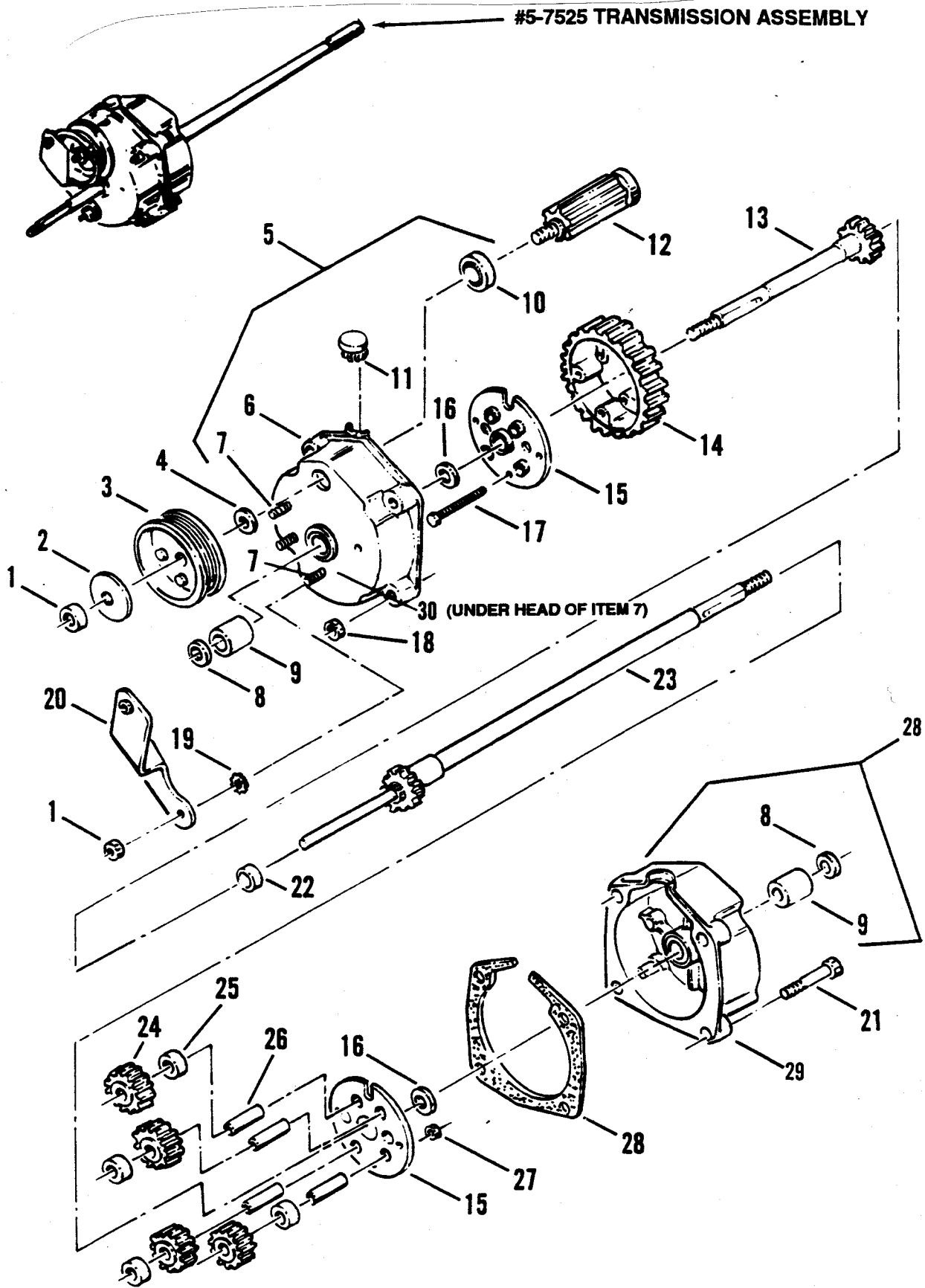

TRANSMISSION (DIFFERENTIAL)

ITEM	PART NO.	DESCRIPTION
-	5-7525	ASSEMBLY, Transmission (Includes items 1 thru 30)
1	1-1201	NUT, 5/16-24 Hex Lock (4)
2	1-4263	WASHER, Spring
3	1-9213	PULLEY, Poly-Vee Belt
4	1-1724	WASHER, Spring
5	5-9794	ASSEMBLY, Housing Right (Includes items 6 thru 10)
6	1-7080	HOUSING, Right Side
7	1-4155	SCREW, 5/16-24x1-1/8" Rib Neck (3)
8	1-2314	SEAL, 5/8 I.D. (2)
9	1-2507	BEARING, Differential (2)
10	1-1767	BEARING, Ball
11	1-6544	PLUG, Housing
12	5-0767	GEAR, Input
13	5-0830	AXLE, Short
14	1-2495	GEAR, Differential (46 Tooth)
15	3-1970	PLATE (2)
16	3-1965	WASHER, Thrust (2)
17	9-0557	SCREW, #10-32x1-1/2" Hex Head Cap (4)
18	1-1774	GASKET, Housing
19	9-0189	WASHER, 5/16 Internal/External Tooth Lock (3)
20	5-1903	BRACKET, Differential
21	9-0911	SCREW, 1/4-20x1-1/4" Self-Tapping (4)
22	1-2543	SPACER, Axle Gear
23	5-0831	AXLE, Long
24	2-1115	GEAR, Pinion (12 Tooth) (4)
25	1-2500	SPACER, Pinion Gear (4)
26	1-1110	SHAFT, Pinion (4)
27	9-0376	NUT, #10-32 Hex Lock (4)
28	5-7523	ASSEMBLY, Housing Left (Includes items 8,9 & 29)
29	1-7015	HOUSING, Left Side
30	2-4442	GASKET, 5/8 O.D.

REAR WHEEL BRACKETS, LATCHES

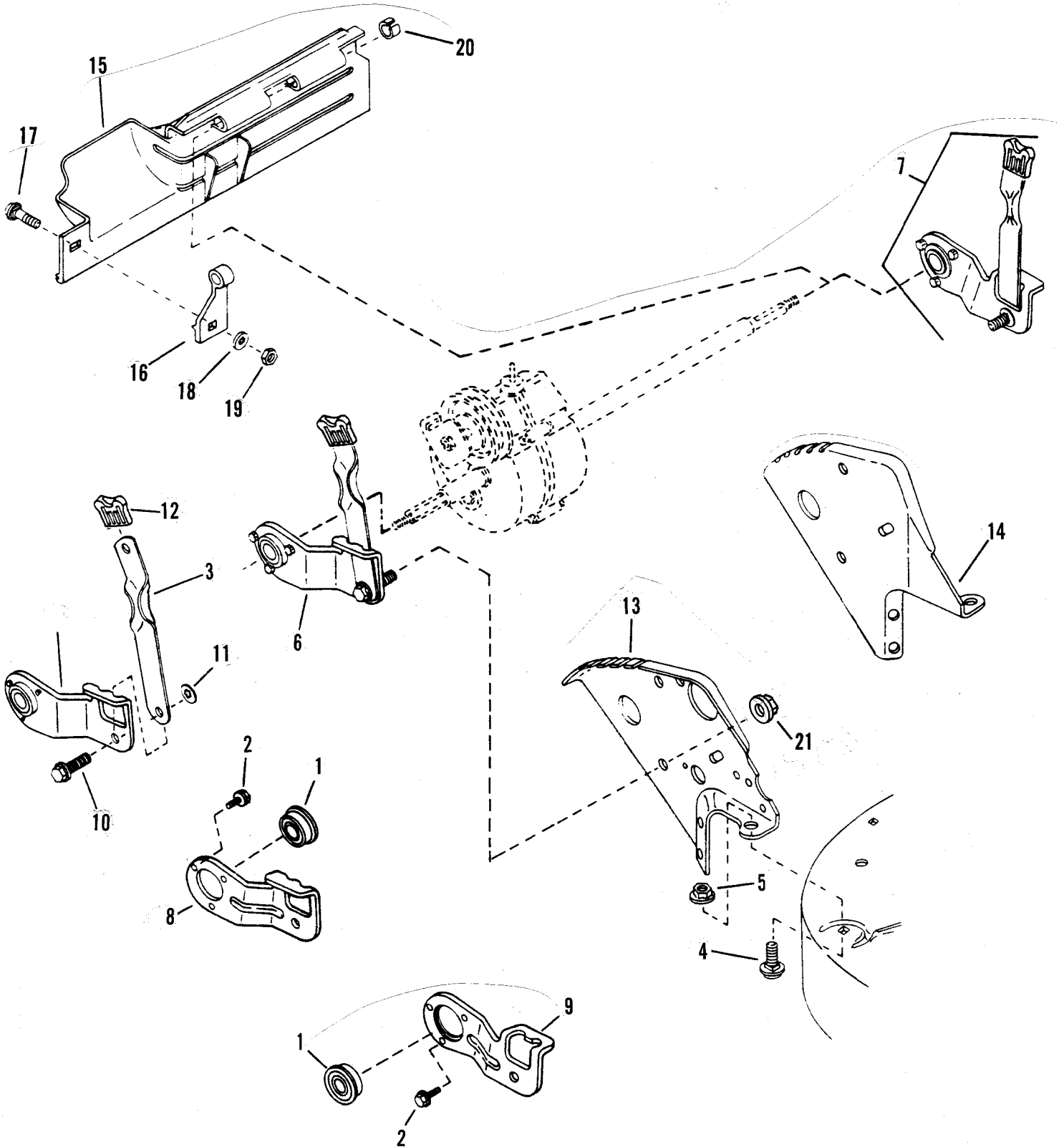

REAR WHEEL BRACKETS, LATCHES

ITEM	PART NO.	DESCRIPTION
1	1-8767	BEARING
2	9-1012	SCREW, #10-32 x 3/8" Self-Tapping (3)
3	1-9218	LATCH, Height Adjusting (Long)
4	9-0001	BOLT, 5/16-18 x 3/4" Short Neck Carriage
5	9-0585	NUT, 5/16-18 Hex Flange Lock (6)
6	5-1814	ASSEMBLY, Wheel Arm (Includes items 1, 2, 3, 8, 10, 11, 12)
7	5-1815	ASSEMBLY, Wheel Arm (Includes items 1, 2, 3, 9, 10, 11, 12)
8	3-2722	ARM, Right Rear Wheel, "P" Models
9	3-2723	ARM, Left Rear Wheel, "P" Models
10	1-5761	BOLT, 5/16-18 x 3/4" Shoulder
11	1-1791	RETAINER, 5/16 Bolt
12	2-7702	GRIP, Latch
13	3-3494	BRACKET, Right Rear Wheel (Self-Propelled "P" Models)
14	3-3495	BRACKET, Left Rear Wheel (Self-Propelled "P" Models)
15	1-9522	GUARD, Rear Foot (Self-Propelled "P" Models)
-	1-7010	GUARD, Rear Foot (Euro Models)
16	1-2616	SUPPORT, Foot Guard
17	9-0005	BOLT, 1/4-20 x 1/2" Short Neck Carriage, Grade 5
18	9-1023	WASHER, 1/4 Internal Tooth Lock
19	9-0063	NUT, 1/4-20 Hex
20	2-3791	RING, Black
21	9-0585	NUT, 5/16-18 Hex Flange Lock

REAR WHEELS

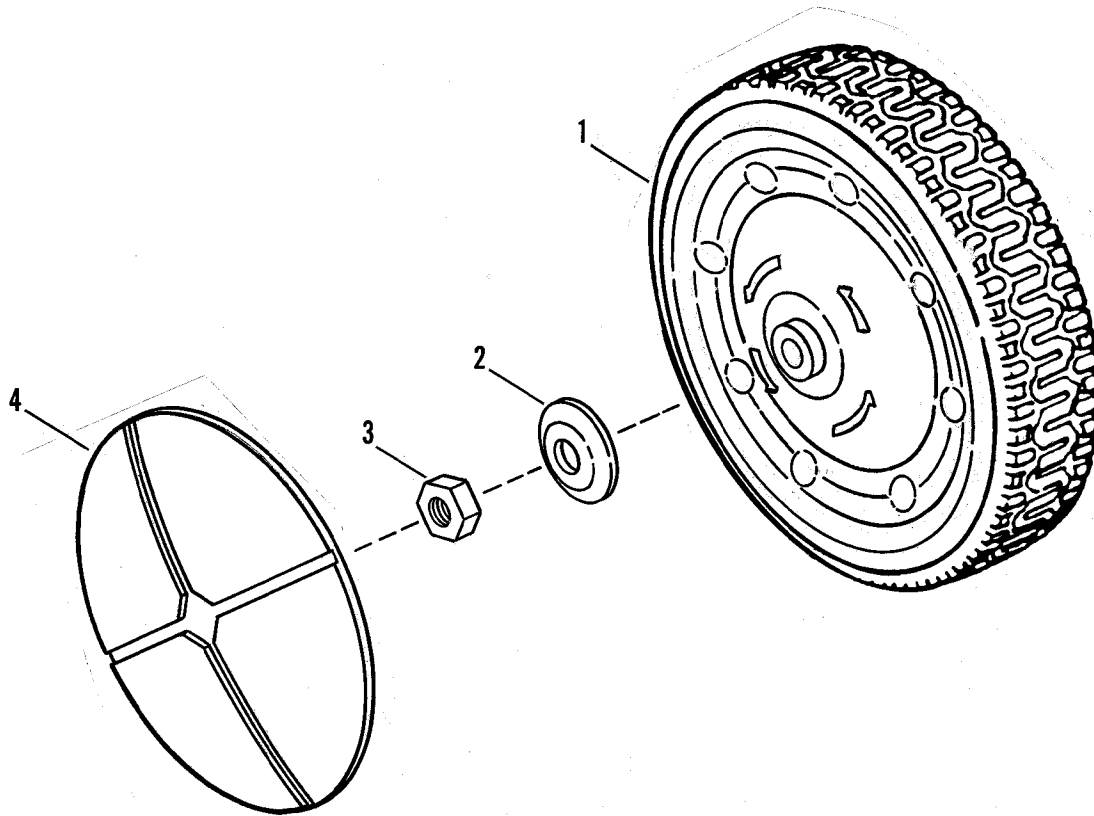

ITEM	PART NO.	DESCRIPTION
1	2-2798	WHEEL, 9 x 2.00, Steel
2	3-1960	HUB-CAP
3	9-0377	NUT, 7/16-20 Hex (Thin)
4	1-9349	WHEEL COVER, 9"

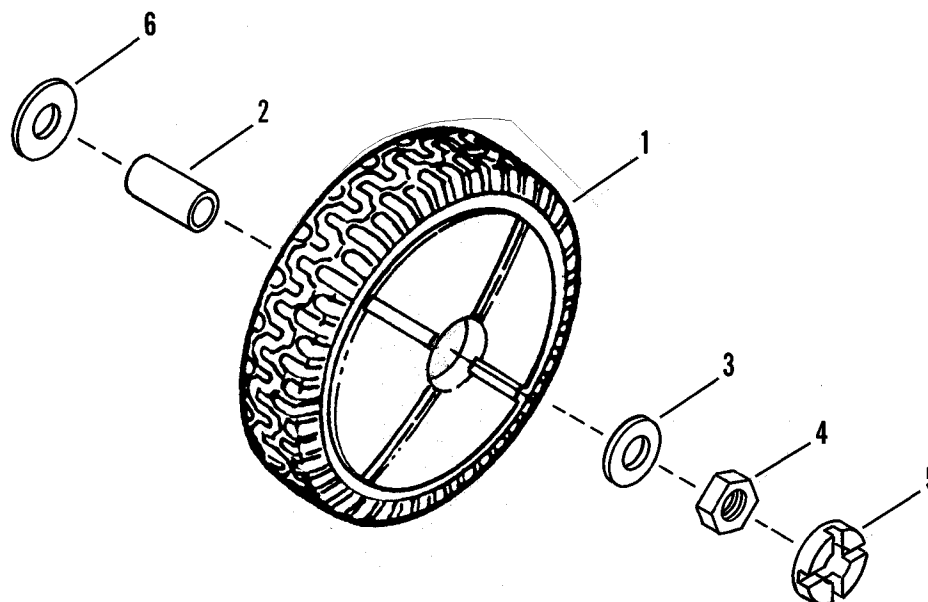

ITEM	PART NO.	DESCRIPTION
1	1-9419	WHEEL, 7 x 1.75, Plastic
2	1-2309	BUSHING, Axle
3	9-1172	WASHER, 7/8" O.D., Flat
4	9-0377	NUT, 7/16-20 Hex (Thin)
5	1-7829	PLUG, Wheel
6	3-1961	WASHER, 1" O.D., Flat

FRONT WHEEL BRACKET, LATCHES

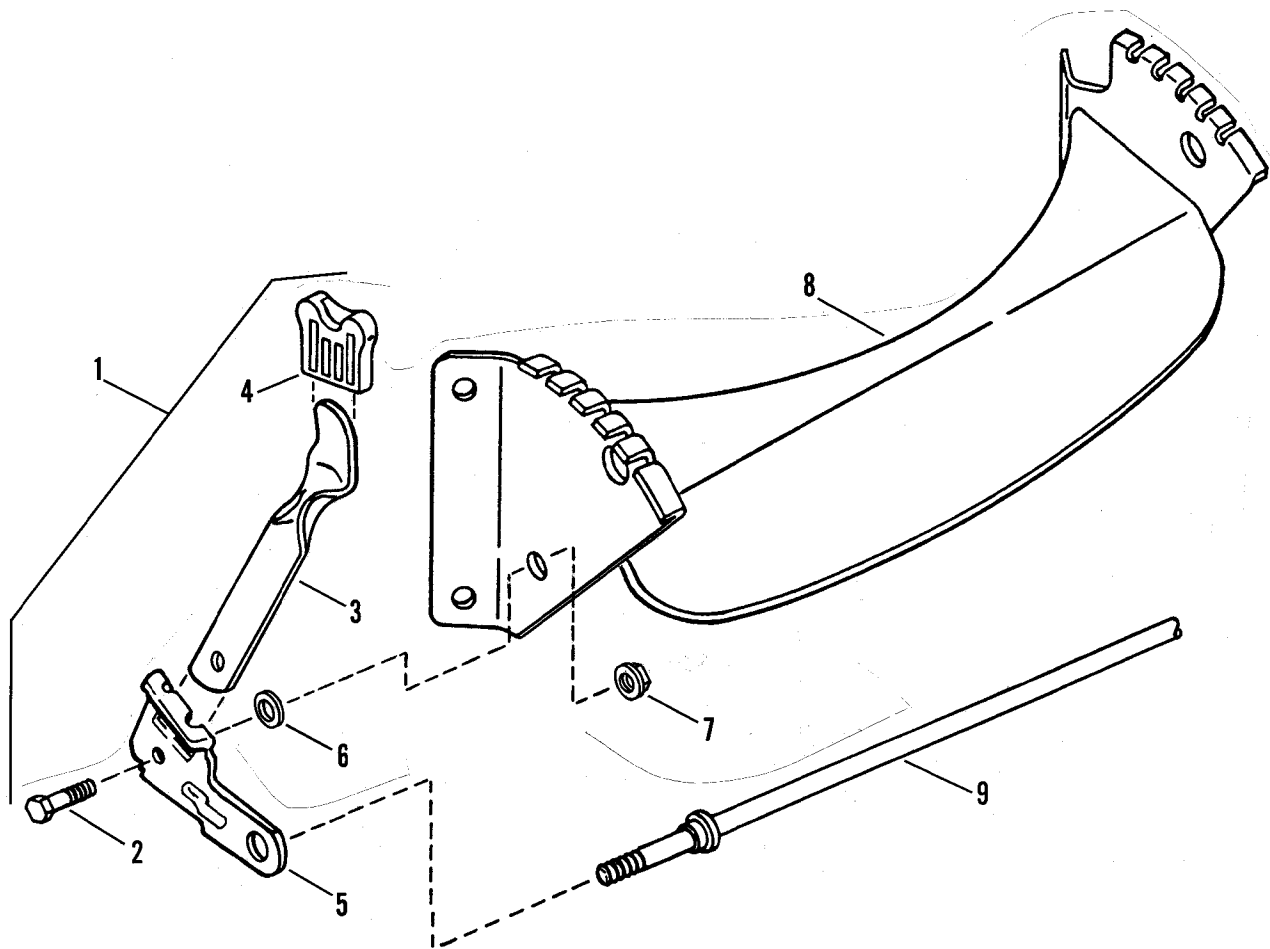

ITEM	PART NO.	DESCRIPTION
------	----------	-------------

1	5-1885	ASSEMBLY, Arm, Left Wheel (Includes items 2 thru 6)
-	5-1886	ASSEMBLY, Arm (Shown), Right Wheel (Includes items 2 thru 6)
2	1-5761	BOLT, 5/16-18 x 3/4" Shoulder
3	1-2325	LATCH, Height
4	2-7702	GRIP, Latch
5	3-1016	ARM, Left Wheel
-	3-1017	ARM, Right Wheel (Shown)
6	1-1791	RETAINER, 5/16 Bolt
7	9-0585	NUT, 5/16-18 Hex Flange Lock
8	4-1328	BRACKET, Front Wheel
9	2-1119	AXLE

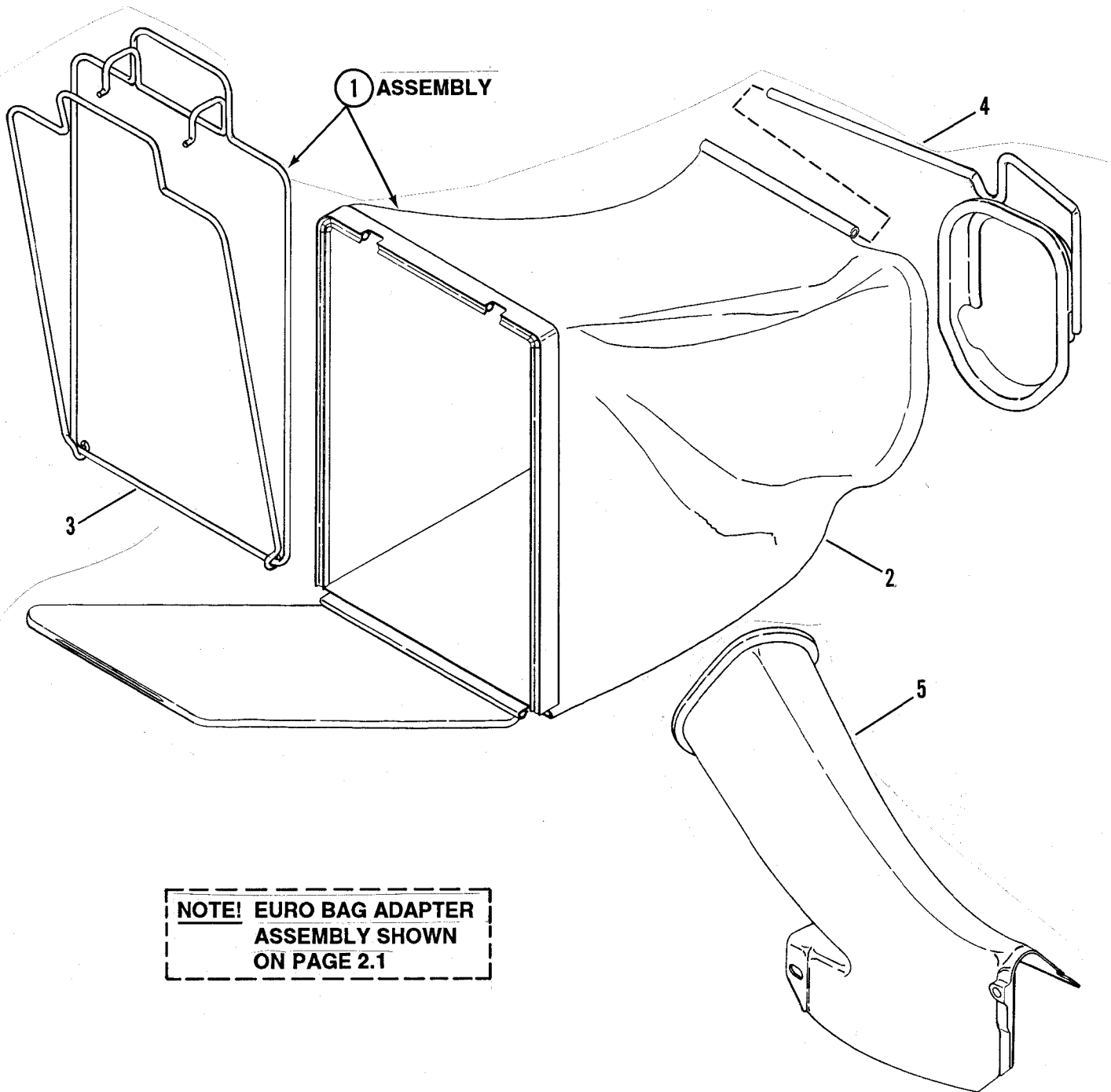

**NOTE! EURO BAG ADAPTER
ASSEMBLY SHOWN
ON PAGE 2.1**

ITEM PART NO. DESCRIPTION

-	6-0935	KIT, Grass Bag Catcher (Includes items 2 thru 5)
1	5-1899	ASSEMBLY, Grass Bag (Includes items 3 & 4)
2	1-7069	BAG, Door Type (Charcoal color)
3	5-1906	ASSEMBLY, Bag Wire
4	4-7969	CONNECTOR, Grass Bag
5	1-6050	ADAPTER, Bag

ACCESSORY, SNAPPERIZER

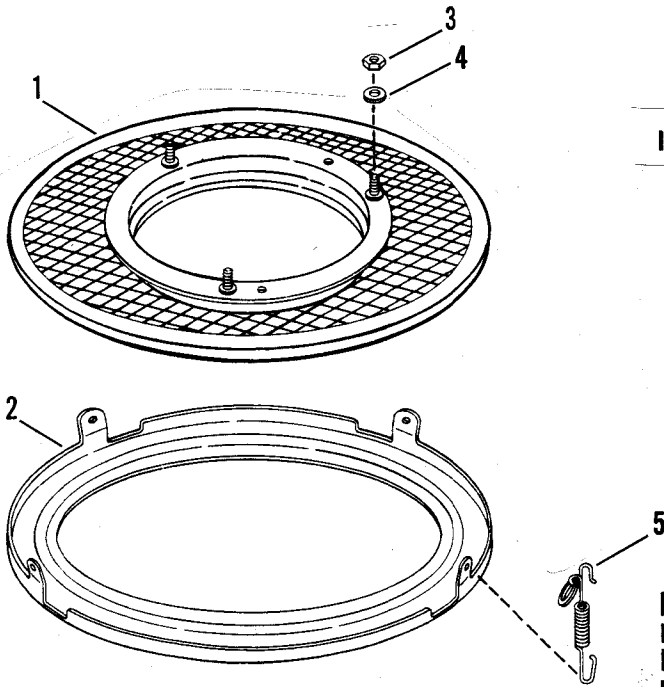

ITEM	PART NO.	DESCRIPTION
-	6-0440	KIT, Snapperizer (Includes items 1 thru 6)
1	5-1243	SCREEN, Fastener Assembly
2	3-9759	RING, Bottom
3	9-0223	NUT, 5/16-24 Hex (3)
4	9-0187	WASHER, 5/16 Split Lock (3)
5	1-2587	SPRING (3)
6	9-0122	WASHER, 3/8 Flat

NOTE! Install 3/8 Flat Washer Between The Screen And The Deck On The Discharge Area Mounting Stud On BBC Models ONLY.

DECALS

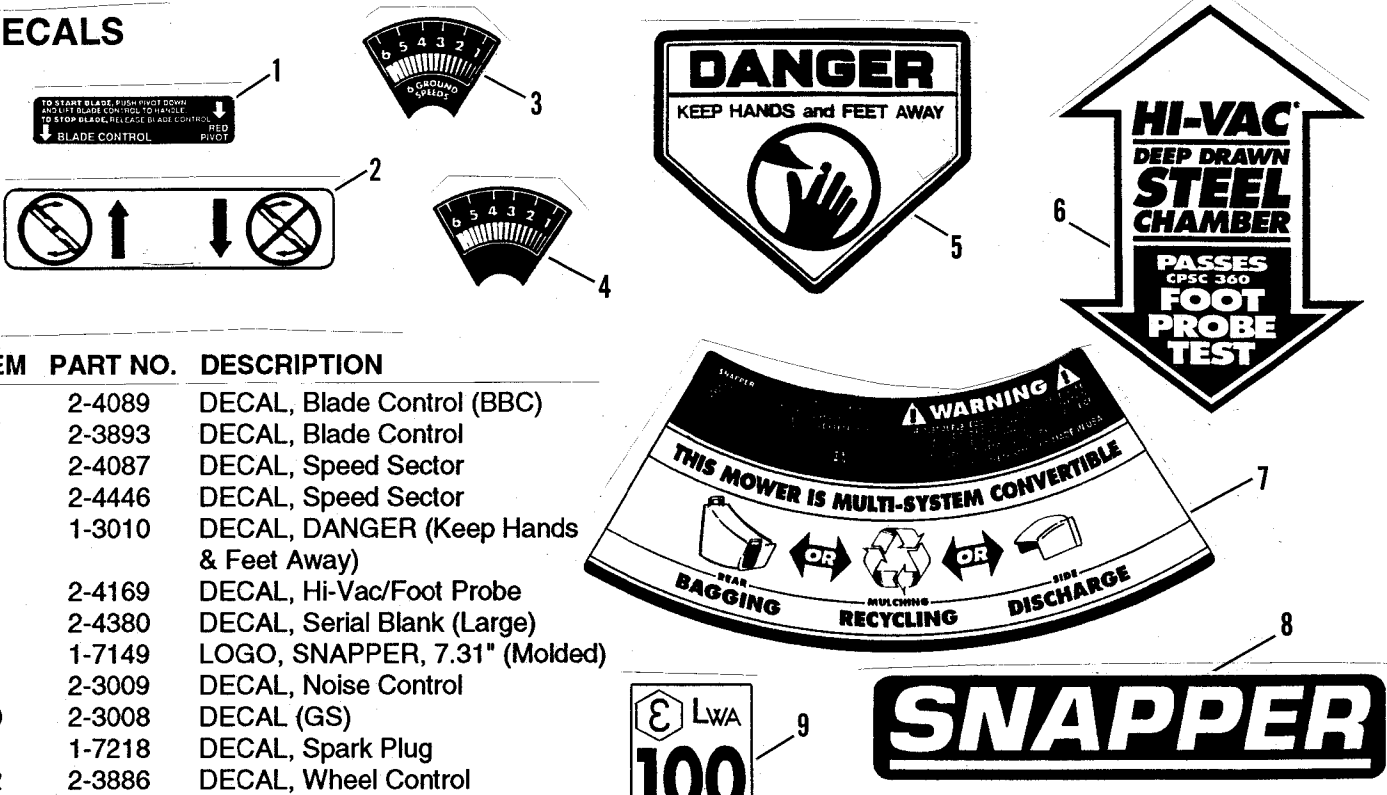

ITEM	PART NO.	DESCRIPTION
1	2-4089	DECAL, Blade Control (BBC)
2	2-3893	DECAL, Blade Control
3	2-4087	DECAL, Speed Sector
4	2-4446	DECAL, Speed Sector
5	1-3010	DECAL, DANGER (Keep Hands & Feet Away)
6	2-4169	DECAL, Hi-Vac/Foot Probe
7	2-4380	DECAL, Serial Blank (Large)
8	1-7149	LOGO, SNAPPER, 7.31" (Molded)
9	2-3009	DECAL, Noise Control
10	2-3008	DECAL (GS)
11	1-7218	DECAL, Spark Plug
12	2-3886	DECAL, Wheel Control

DECALS 2, 4, 9, 10, 11 & 12 ARE FOR EUROPEAN MOWERS ONLY.

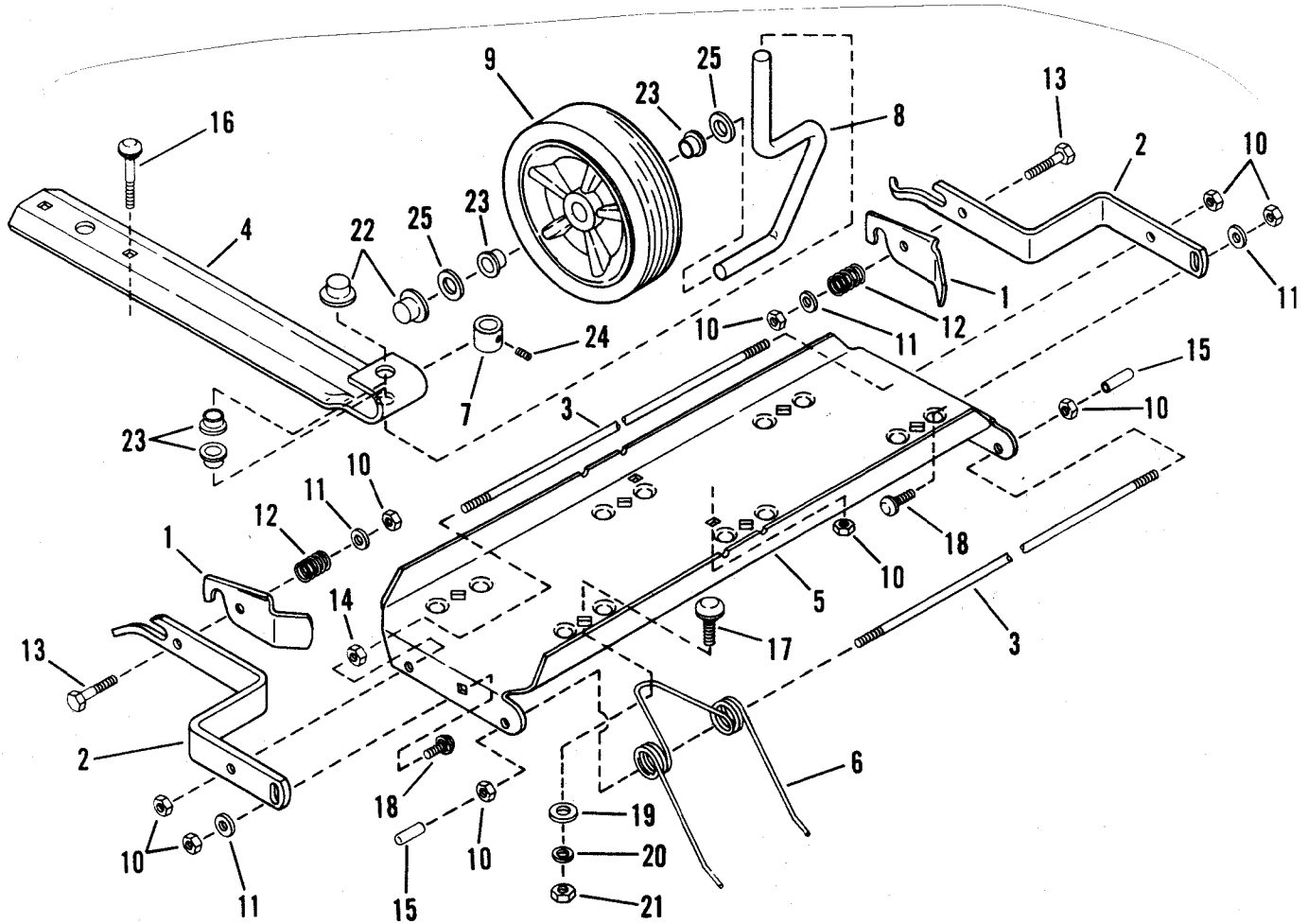

ITEM	PART NO.	DESCRIPTION	ITEM	PART NO.	DESCRIPTION
-	6-0476	KIT, Thatcherizer (Includes 1 Thru 27)	14	9-0063	NUT, 1/4-20 Hex (2)
1	1-4113	LATCH, Frame Attachment (2)	15	2-2424	CAP, Vinyl (2)
2A	1-8497	BAR, Mount (Right Hand)	16	9-0798	BOLT, 1/4-20 x 2-1/2" Carriage (2)
2B	1-8498	BAR, Mount (Left Hand)	17	9-0383	BOLT, 5/16-18 x 1" Carriage (6)
3	1-8499	ROD, Tine (2)	18	9-0074	BOLT, 1/4-20 x 3/4" Carriage (2)
4	1-8700	SUPPORT, Wheel	19	1-4098	WASHER, Reinforcing (6)
5	1-9948	TRAY, Tine	20	9-0187	WASHER, 5/16 Split Lock (6)
6	1-8496	SPRING, Tine Thatching (6)	21	9-0196	NUT, 5/16-18 Hex (6)
7	1-4100	BUSHING, Wheel Adjuster	22	1-4101	NUT, 1/2 Push (2)
8	1-8493	AXLE, Wheel	23	1-4342	BEARING, Nyliner (4)
9	1-8189	WHEEL, 7.00 x 1.50 Gage	24	1-4103	SCREW, 5/16-18 x 1/4" Set
10	9-0761	NUT, 1/4-20 Hex Lock (10)	25	9-0250	WASHER, 1/2 Flat (2)
11	9-0055	WASHER, 1/4 Flat (4)	26	1-4115	DECAL, Adjustment (Not Shown)
12	2-2425	SPRING, Compression (2)	27	1-4062	DECAL, Thatcherizer (Not Shown)
13	9-0825	BOLT, 1/4-20 x 1-1/4" Hex	-	6-0965	KIT, Adapter (Includes Items 1, 2 & 10 Thru 13)

PARTS MANUAL FOR

SNAPPER®

**21" SERIES 8
BLADE BRAKE CLUTCH
WALK BEHIND
MOWERS**

IT IS THE POLICY OF SNAPPER POWER EQUIPMENT TO IMPROVE ITS PRODUCTS WHENEVER IT IS POSSIBLE AND PRACTICAL TO DO SO. WE RESERVE THE RIGHT TO MAKE CHANGES OR ADD IMPROVEMENTS AT ANY TIME WITHOUT INCURRING ANY OBLIGATION TO MAKE SUCH CHANGES ON PRODUCTS MANUFACTURED PREVIOUSLY.

SNAPPER POWER EQUIPMENT
McDonough, GA., 30253 U.S.A.



(Rev. 1, 6/96)

MANUAL #06133