



Cuisine Series Heavy Duty Combination Top Range

Item: _____
 Quantity: _____
 Project: _____
 Approval: _____
 Date: _____

Cuisine Series Heavy Duty Combination Top Range

Models:

- C836-11 C0836-11 C0836-11M C836-11R C0836-11R C0836-11RM

Range with
18" Front Fired Hot Top &
18" Even Heat Hot Top



Model C386-11

Note: Range-based convection oven models can be located in the middle of a battery, banked back-to-back with other equipment, and can be positioned against a wall

Standard Features:

- 18" (457mm) even heat hot top section, 32,500 BTUs
- 18" (457mm) front fired hot top section 37,500 BTUs
- Full-range burner valve control
- Removable lids and rings on front fired hot top section
- Stainless steel front and sides
- Stainless steel front rail w/ position adjustable bar
- 1-1/4" NPT front gas manifold
- Can be connected individually or in a battery
- Automatic lighting - all burners
- 6" (152mm) H stainless steel stub back
- 6" (152mm) chrome steel adj. legs
- Stainless steel oven interior w/ removable porcelain bottom
- 40,000 BTU oven burner
- Chrome plated rack with four positions, 1 per oven
- Fully insulated oven interior
- 100% safety oven pilot
- Oven thermostat control - 150°-500°F (66°-260°C)

- Porcelain oven interior in lieu of stainless steel interior - NC
- Single or double deck high shelf or back riser
- Modular unit w/ legs & shelf (suffix M)
- Modular unit w/o legs on Refrig. Base (change suffix M to PC)
- Stainless steel intermediate shelf for cabinet base
- Stainless steel door(s) for cabinet base units
- Stainless steel back
- Continuous plate shelf, 48-72" for battery installations
- Gas shut-off valves - 3/4", 1", 1 1/4" NPT (Specify)
- Gas regulator: 3/4"- 1 1/4" NPT (Specify)
- Gas flex hose w/ quick disconnect 3/4", 1", 1 1/4" (Specify)
- Stainless steel legs (set of four)
- Flanged feet set of four
- Swivel casters (4) w/ front locking
- Casters w/ polyurethane wheels - non marking
- Extra oven rack
- Rear Gas Connection; 3/4" NPT (max 250,000 BTU's) or 1-1/4" NPT

Optional Features:

- Range base convection oven (add RC)

Specifications:

U.S. Range Cuisine 36" (914mm) wide Heavy Duty Range Series. Model _____ with total BTU/hr rating of _____ when used with natural/propane gas. Stainless steel front and sides. 6" (152mm) legs with adjustable feet.

Ovens - One piece oven door. Stainless steel oven interior with a heavy-duty, "keep-cool" door handle. Standard oven comes with a thermostat with a temperature range from 150° (low) to 500°F (66°-260°C). One chrome plated oven rack for standard ovens and three for convection ovens.

18" (457mm) Section Front-Fired Hot Tops - 12,500 BTU/hr each burner with three per section.

18" (457mm) Section Even Heat Hot Tops - 32,500 BTU/hr each burner with one per plate.



NOTE: Ranges supplied with casters must be installed with an approved restraining device.

Garland Commercial Industries, LLC
 185 East South Street
 Freeland, PA 18224
 Phone: (570) 636-1000
 Fax: (570) 636-3903

Garland Commercial Ranges Ltd
 1177 Kamato Road,
 Mississauga, Ontario
 L4W 1X4 CANADA
 Phone: 905-624-0260
 Fax: 905-624-5669

Enodis UK LTD
 Swallowfield Way,
 Hayes, Middlesex
 UB3 1DQ ENGLAND
 Telephone: 081-561-0433
 Fax: 081-848-0041

Enodis

Model #	Description	Total BTU (NAT. Gas)
C836-11*	(1) FFHT & (1) EHHT(Left) - Standard Oven	110,000
C0836-11	(1) FFHT & (1) EHHT(Left) - Cabinet	70,000
C0836-11M	(1) FFHT & (1) EHHT(Left) - Modular	70,000
C386-11R	(1) FFHT & (1) EHHT(Right) - Standard Oven	110,000
C0836-11R	(1) FFHT & (1) EHHT(Right) - Cabinet	70,000
C0836-11RM	(1) FFHT & (1) EHHT(Right) - Modular	70,000

Individual Burner Ratings (BTU/hr)		
Burner	NAT.	Pro.
18" Front Fired Hot Top	12,500 (3 per 18" Section)	
18" Hot Top	32,500	32,500
Std. Oven	40,000	35,000
Conv. Oven	37,000	35,000

FFHT = Front Fired Hot Top

EHHT = Even Heat Hot Top

* Add Suffix "RC" for Convection Oven Base

Interior Dimensions: In (mm)			
Product	Height	Width	Depth
Standard Oven	13-1/2(323)	26-1/4 (667)	29 (737)
Convection Oven	13-1/2(323)	26-1/4 (667)	25 (635)
Cabinet Base	20-1/2 (521)	32-1/4 (819)	31 (787)

Gas Pressure	NAT.	PRO.
Minimum Supply	7" WC	11" WC
Manifold Operating Pressure	6" WC	10" WC

Gas Manifold 1-1/4" NPT

Model C836-11

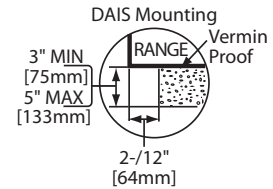
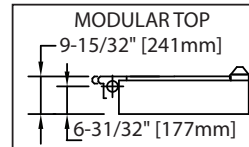
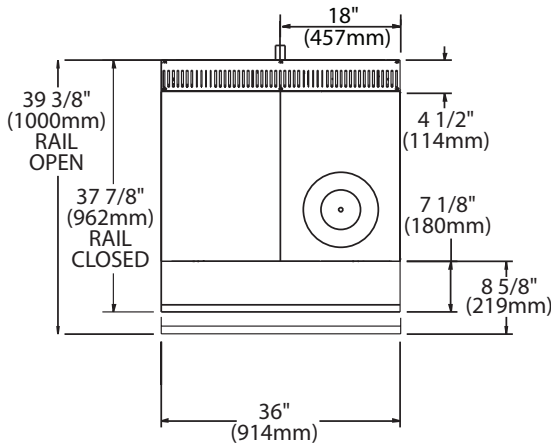

Model C336-11R

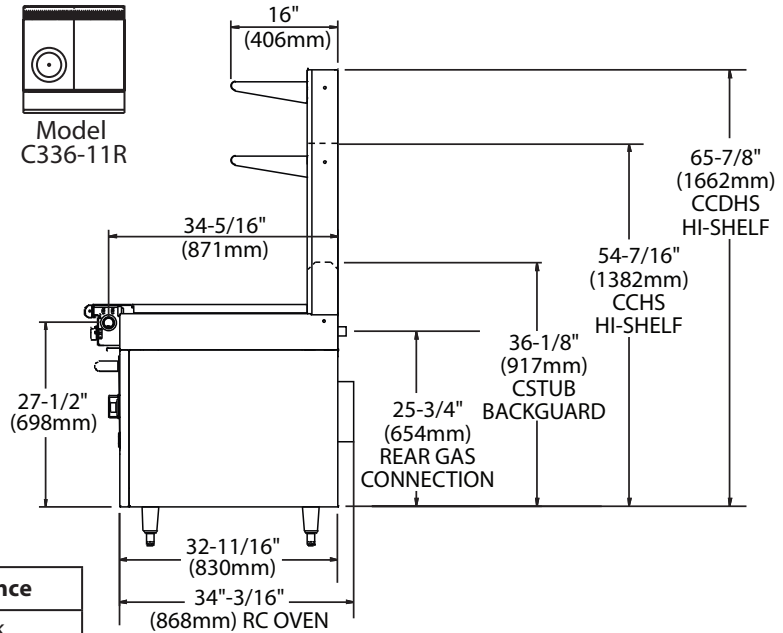
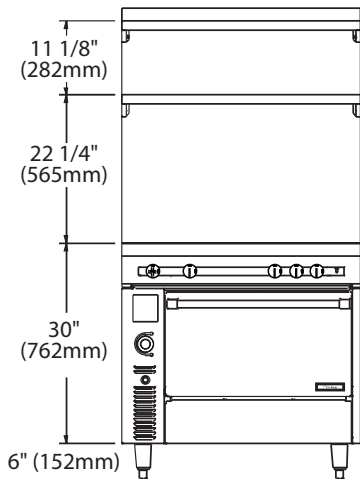

Combustible Wall Clearance	
Sides	Back
6" (152mm)	6" (152mm)

Form# C836-11 (08/07)