

OPERATOR'S MANUAL TWIN BAG GRASS CATCHER

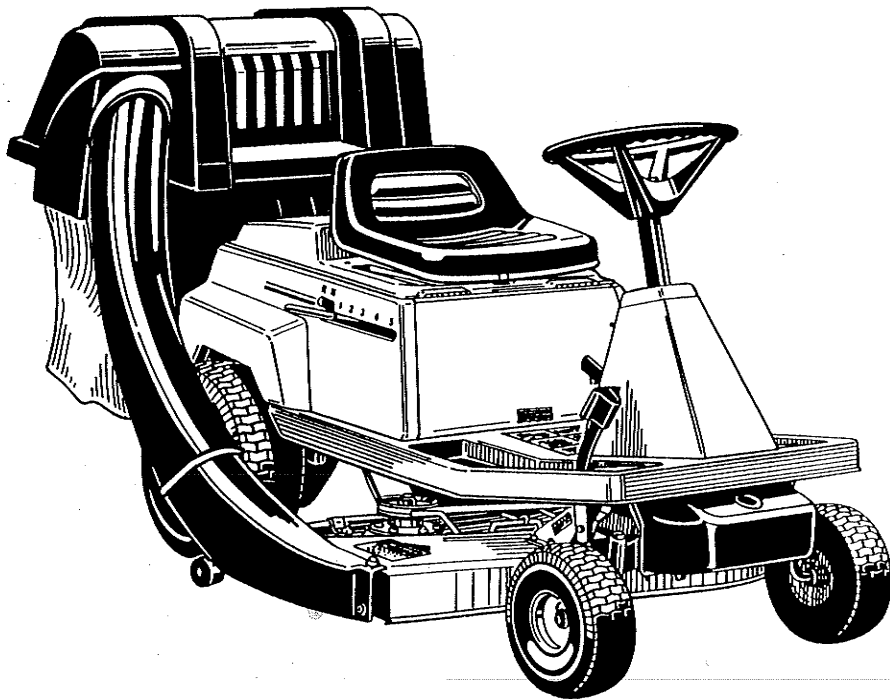

GRASS CATCHER
FOR REAR ENGINE RIDER

30" MOWER

MFG. NO. 1691789

36" MOWER

MFG. NO. 1691790

FORM - 1704956
PRINTED IN U.S.A.
4/90

STANDARD FASTENER IDENTIFICATION CHART

Hardware sizes are given in the illustrations throughout this manual.

If a washer or nut is identified as "washer, 1/2" or "nut, 1/2", this means the inside diameter is 1/2 inch.

If a screw is identified as "screw, 1/2 x 2", this means the shaft diameter is 1/2 inch and the shaft of the screw is 2 inches long. If a screw is identified as "screw, 1/2-16 x 2", the number "16" means that the screw has 16 threads per inch.

SAMPLE: SCREW IDENTIFICATION

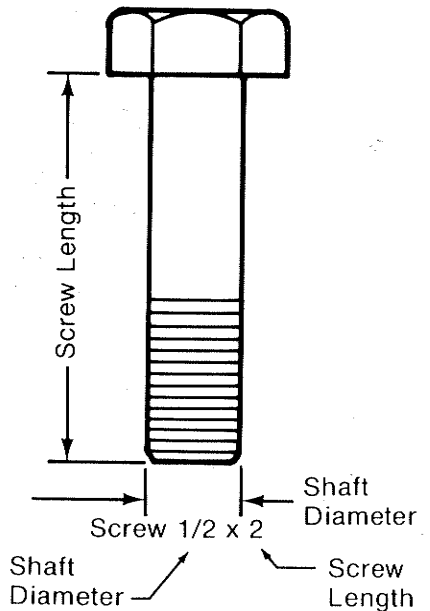

SAMPLE: NUT IDENTIFICATION

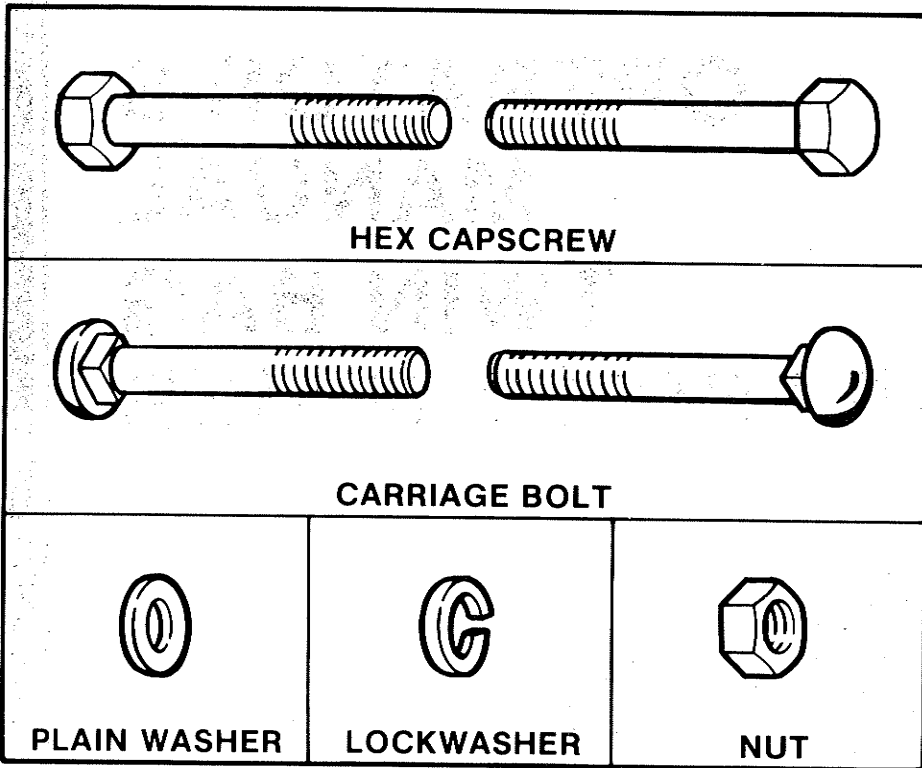
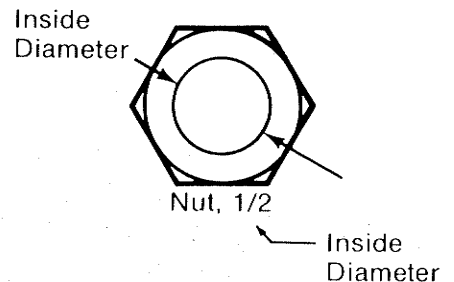

HEX CAPSCREW IDENTIFICATION

Shown below are actual size hex heads for standard screw sizes. Example: a 1/4" screw has a 7/16 head and thus requires a 7/16 wrench. To measure length, use the scale below.

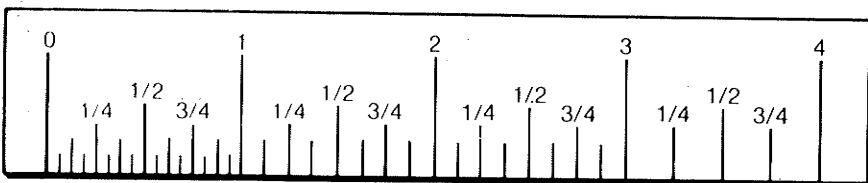
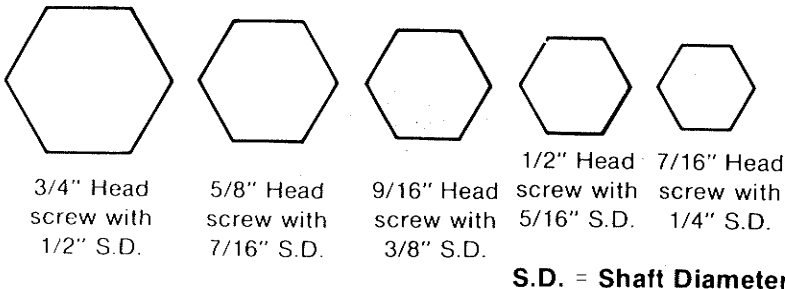

WASHER AND NUT IDENTIFICATION

Place the washer or nut on the above scale to determine the inside diameter. The actual inside diameter can vary 1/16 inch. Use the scale for comparison.

Table of Contents

STANDARD FASTENERS	Inside Front Cover
SAFETY DECALS	1
SAFETY RULES	2
ASSEMBLY INSTRUCTIONS	3
ADAPTER & BLADE ASSEMBLY - 30" Mowers	3
ADAPTER, BAFFLE & BLADE ASSEMBLY - 36" Mowers	5
FRAME AND BAGGER SUPPORT ASSEMBLY	8
GRASS CATCHER ASSEMBLY	10
COUNTERWEIGHT ASSEMBLY	13
OPERATION AND STORAGE	14
BEFORE OPERATION	14
OPERATION	14
EMPTYING THE BAGS	14
REMOVAL	14
STORAGE	14
TROUBLESHOOTING	15
TORQUE SPECIFICATIONS	Inside Rear Cover

Safety Decals

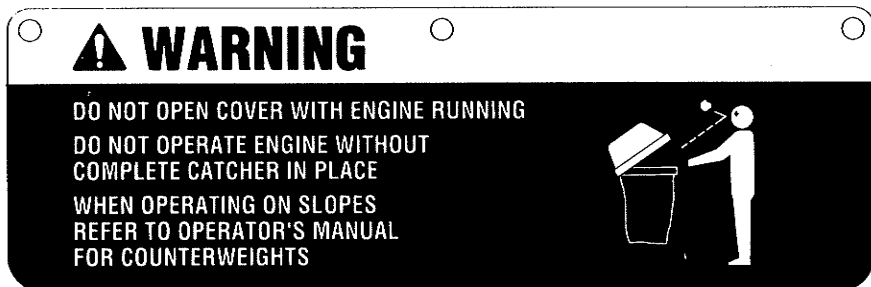

This bag is subject to deterioration and wear during normal usage. Inspect the bag periodically for tears, holes or weak spots and replace with a new bag meeting manufacturers durability requirements.



Safety Rules



Read these safety rules and the safety rules in your Operator's Manual and follow them closely. Failure to obey these rules could result in loss of control of vehicle, severe personal injury to yourself, or damage to property or equipment. The triangle  in the text signifies important cautions or warnings which must be followed.

ATTENTION SETUP PERSONNEL:

As setup personnel you have the obligations to know the product better than the customer. This includes safety related items. Prior to setup, thoroughly familiarize yourself with the Operator's Manual. Pay special attention to all safety warnings. Remember, it is your responsibility to set up the product safely and to know it well enough to be able to instruct a customer in the safe use of this power unit.

It is possible during setup to place yourself in a position which is more hazardous than when the unit is in operation. Safety is a matter of common sense . . . A matter of thinking before acting. Most shops have specific safety practices. Follow them. The precautions listed in the Operator's Manual should not supersede existing practices but should be considered as supplemental information.

1. Know the controls and how to stop the rider quickly. READ THE RIDER'S OPERATOR'S MANUAL.
2. Shut the engine (motor) off before attaching, adjusting or disconnecting the collection system.
3. Check the grass catcher frame to make sure it is attached securely to rider.
4. Look behind to make sure the area is clear before backing up.



WARNING

Do not operate the rider unless the entire grass catcher system or mower discharge deflector is properly installed.

5. **CAUTION:** For added rider stability and to prevent tipping or loss of control;
 - a. DO drive in reduced speed on uneven ground and when turning corners.
 - b. Reduce loads on hillsides. It is recommended that the Collection System be kept only half full when negotiating any slopes. Start mowing on slopes when the Collection System is empty.
 - c. Mow up and down the face of slopes: **never across the face of any slope.**
6. **CAUTION:** Objects may be thrown from mower. For your safety:
 - a. DO NOT open the cover while the mower blades are turning. Shut off the engine before removing the grass chute.
 - b. Be sure the complete Collection System is in place (cover secure and grass chute connected) before operating the mower.
 - c. DO check the cover and bags frequently for wear and tear. Replace with new bags for safety protection.
7. For best results when mowing grass: Set the mower to cut off from 1 to 2 inches of grass. If grass is exceptionally tall, set your mower as high as possible for first cutting. Lower cutting height at succeeding cuttings until proper height is reached. It may be necessary to mow tall grass at a slower rider ground speed.



WARNING

Before raising cover, disengage mower, turn off engine and remove the key. Do not remove catcher tube from adapter or cover while mower is running.

Assembly Instructions

ADAPTER & BLADE ASSEMBLY - 30" MOWER

NOTE

For 36" mower decks, go to step 9.

1. Place the mower in highest cutting height. Set the parking brake. Tape the deflector to side of rider.
2. Place wood blocks (2" x 4" or 4" x 4") under the front tires to provide more clearance to install the lifts. Place a wood block under the front edge of mower deck to prevent mower from falling in case height control lever is accidentally knocked out of latched position.
3. Install the lifts on blade on discharge side as shown in figure 1. Then, remove the wood blocks.
4. Locate two holes at top of opening. In rear hole, insert 5/16-18 x 3/4 carriage bolt (E, figure 2) from bottom and install 5/16 jam nut (F, figure 2) on top of deck to hold carriage bolt in place.
5. Install steel plate (A, figure 2) on underside of adapter with two 10-24 x 5/8" flathead screws (B) and secure with flat washers (C) and 10-24 nyloc nuts (D).
6. If there is no hole to front of adapter opening, a 13/32 inch hole must be drilled and then filed square. To locate the hole, mount the adapter on carriage bolt and mark the location of the front hole.

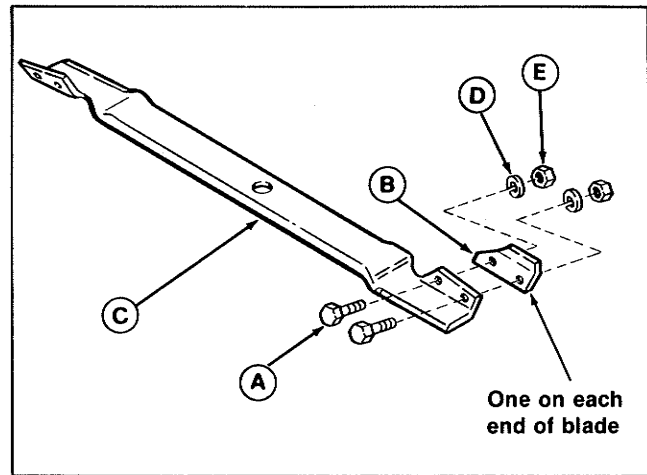

Figure 1.

- A. Capscrew, 1/4-20 x 5/8"
- B. Lift
- C. Blade
- D. Lockwasher, 1/4
- E. Nut, 1/4

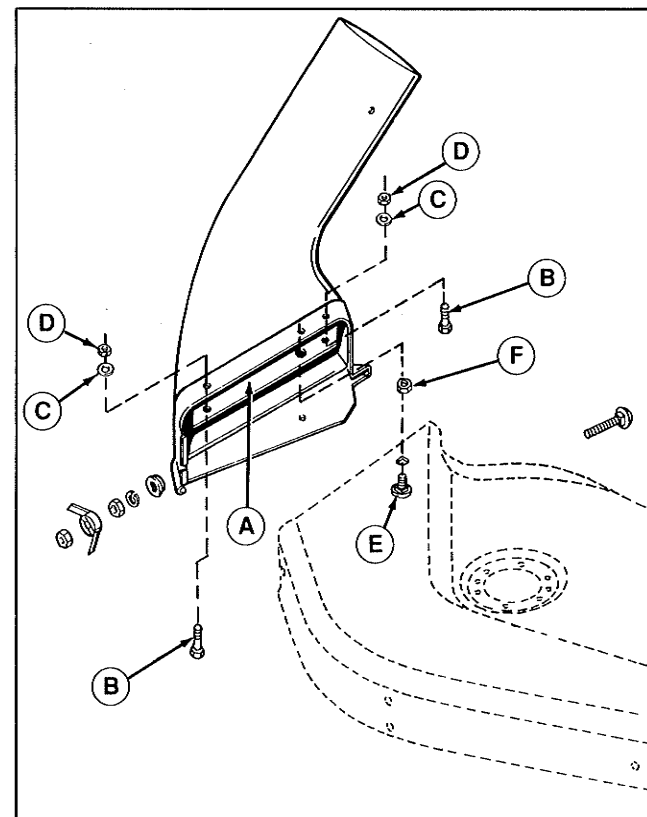

Figure 2.

- A. Steel Plate
- B. Flathead Screw, 10-24 x 5/8"
- C. Flat Washer
- D. Nyloc Nut
- E. Carriage Bolt, 5/16-18 x 3/4
- F. Jam Nut

7. Install carriage bolt (B, figure 3) through front hole in deck and install wing nut assembly (A). Install cup (small end towards deck), lockwasher, nut, wing nut, and centerlock nut. Lockwasher and nut must be seated inside cup and centerlock nut should be flush with end of carriage bolt.

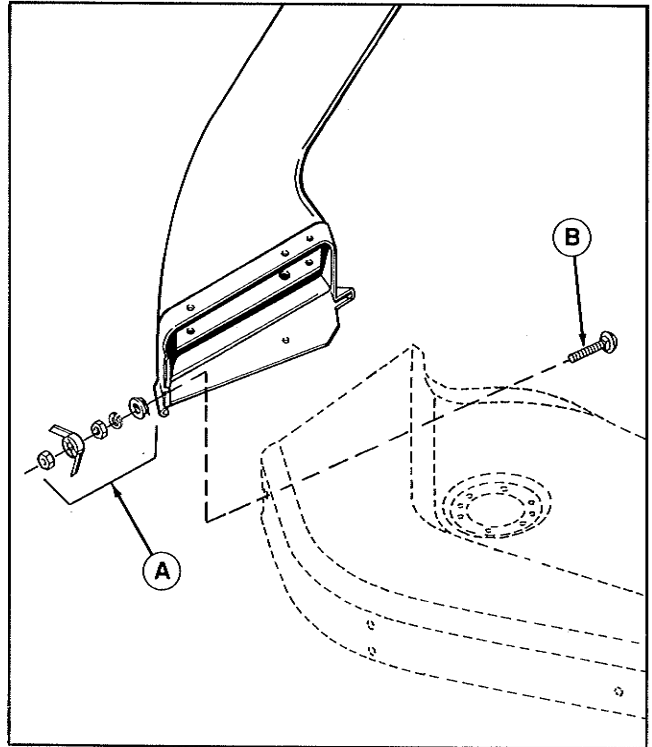

Figure 3.
A. Wing Nut Assembly
B. Carriage Bolt, 5/16-18 x 2-1/4"

8. Place adapter over rear carriage bolt (A, figure 4). Position front slot between mower deck and wing nut (B) and tighten wing nut.

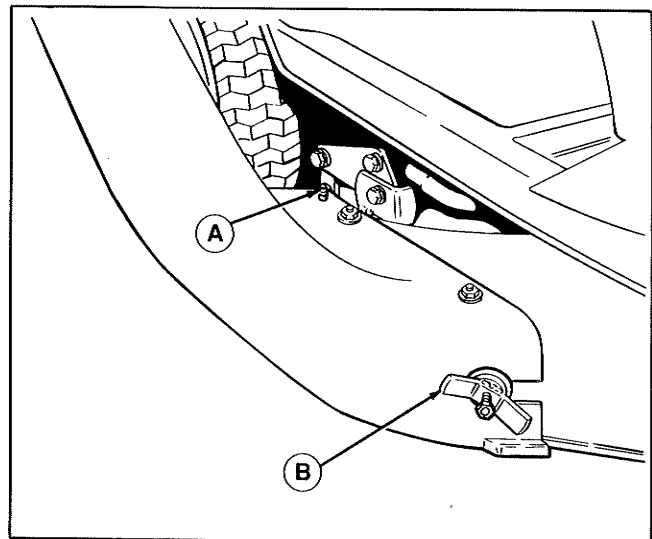

Figure 4.
A. Carriage Bolt
B. Wing Nut

**ADAPTER, BAFFLE AND BLADE ASSEMBLY -
36" MOWER**

NOTE

For 30" mower, continue assembly at step 18.

9. Remove mower from rider. Remove the mower discharge deflector. Carriage bolts will be reinstalled.
10. For early model mowers without mounting holes for the baffle, drill a 9/32" hole in housing 1/2" from edge of opening and 1-3/8" from bottom as shown in figure 5. (The second hole will be drilled later).

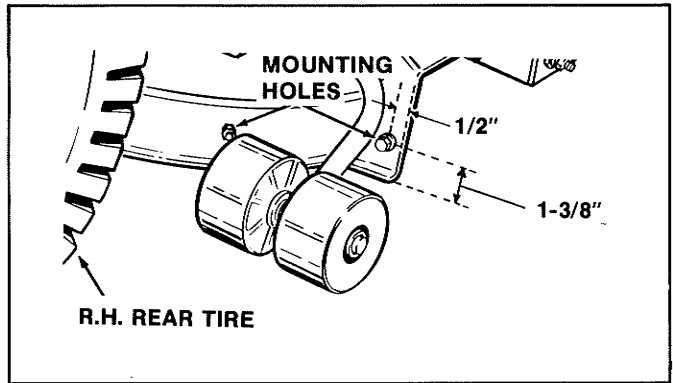

Figure 5.

11. Make sure the retainer nut (A) is in the baffle.
12. Install the baffle into deck with the whizlock screw (B). If the second hole must be drilled, position the baffle parallel with bottom edge of mower deck. Also turn blade to make sure there is no interference. Mark the spot and drill a 9/32" hole as shown in figure 6.
13. Install the carriage bolt (E), lockwashers and nut.

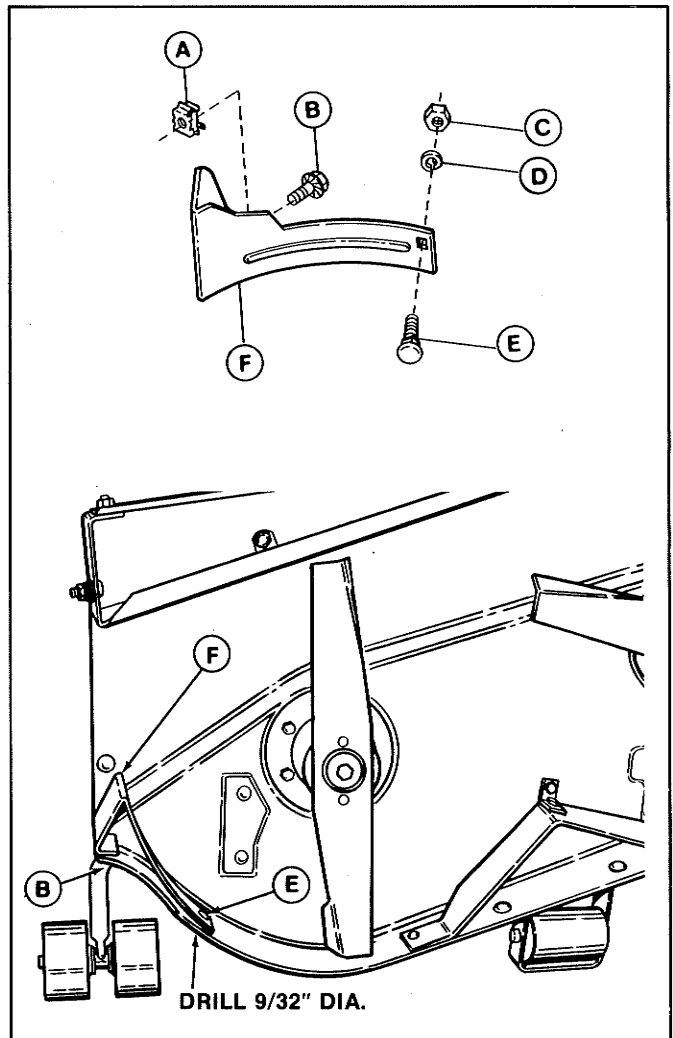

Figure 6.

- A. Retainer Nut
- B. Whizlock Screw
- C. Nut
- D. Lockwasher
- E. Carriage Bolt
- F. Deflector Baffle

14. Install the discharge baffle (A) as shown. Insert bolt (L) and install push nut (K) fully onto threads to hold bolt (L) in place. (The lockwasher (F), washer (H) and nut (J) will be used to install adapter.

Figure 7.

- A. Baffle
- B. Screw, Self Tapping, 5/16-18 x 1/2
- C. Carriage Bolt, 3/8-16 x 3/4
- D. Carriage Bolt, 5/16-18 x 3/4
- E. Washer, 1/4
- F. Washer, 3/8
- G. Lockwasher, 5/16
- H. Lockwasher, 3/8
- I. Nut, 5/16-18
- J. Nut, 3/8-16
- K. Push Nut
- L. Carriage Bolt, 3/8-16 x 3/4

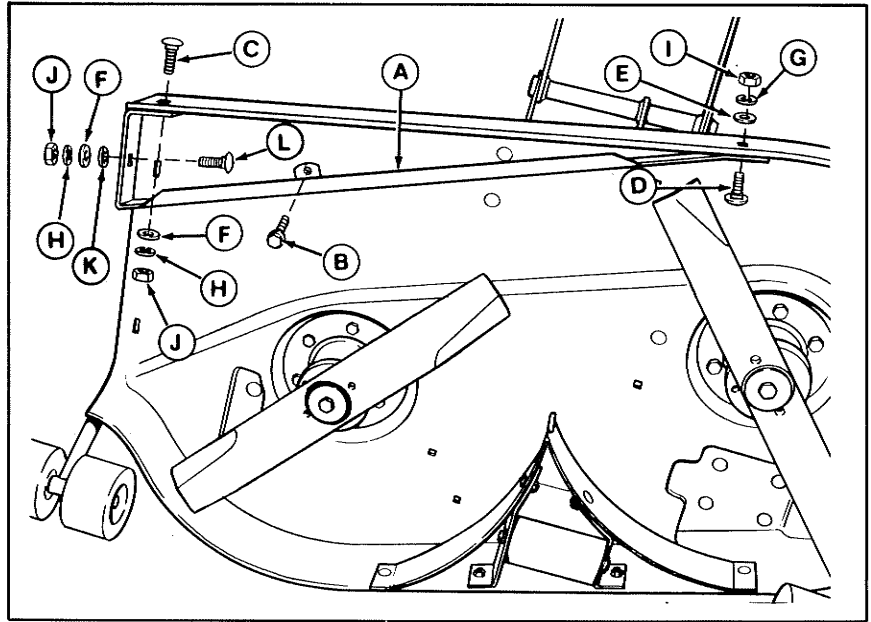

WARNING

Blade mounting capscrews must be installed with the cup washer and spline washer and then securely tightened. Torque blade mounting capscrews to 50-70 ft. lbs. (68-76 Nm).

WARNING

Do not handle the mower blades with bare hands. Avoid touching the cutting edge. Careless or improper handling may result in serious injury.

15. Remove the mower blades and install the new blades with tabs pointing up (toward mower deck). Install the washers and capscrew. Make sure the spline washer engages the shaft splines. Make sure the cup washer is installed concave side up (toward mower deck). Block the blade and torque capscrew to 50-70 ft. lbs. (68-76 Nm). Note the difference between the left-hand and right-hand blades.

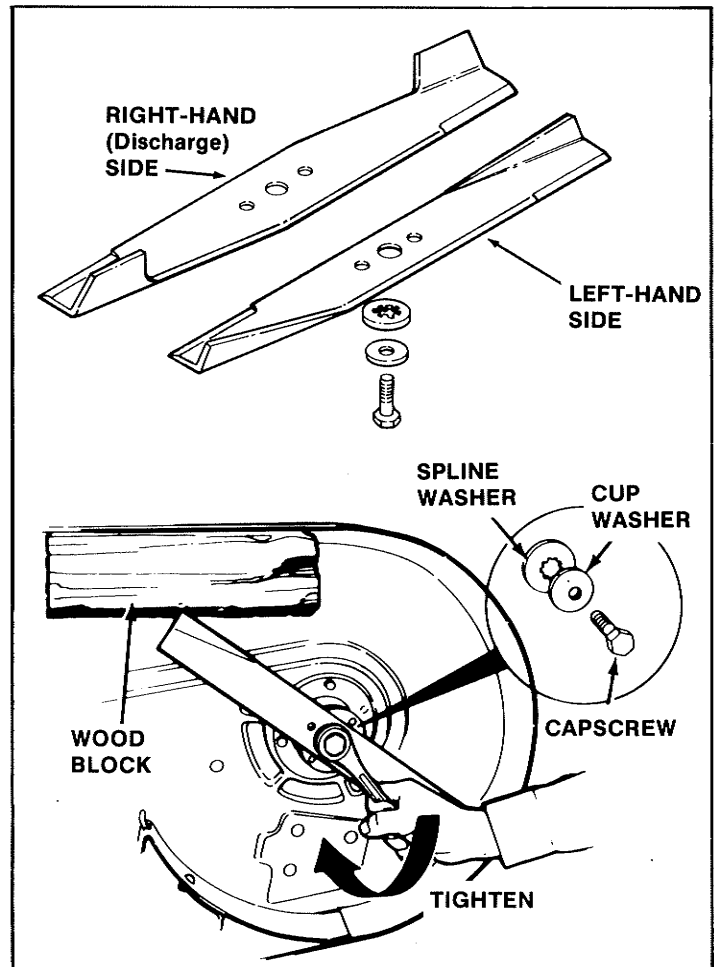

Figure 8.

16. Reinstall the deflector carriage bolts (B, figure 9) and the supplied push nuts (A);

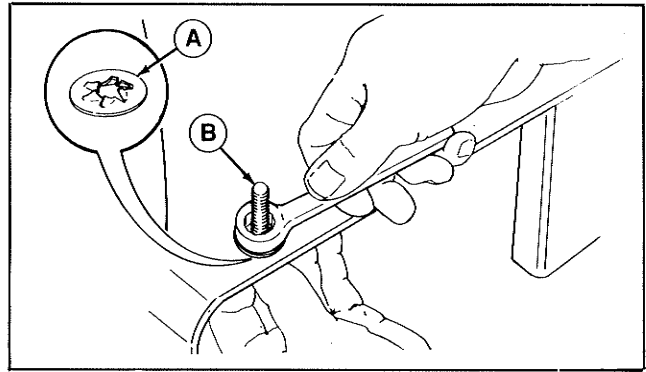

Figure 9.
A. Push Nut
B. Carriage Bolt

17. Place the adapter onto the three screws and install 3/8 plain washers, 3/8 lockwashers and 3/8 nuts.

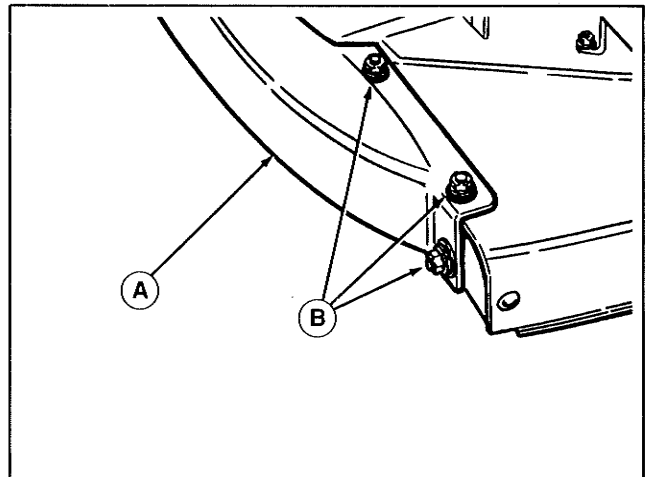

Figure 10.
A. Adapter
B. Hardware

FRAME AND BAGGER SUPPORT ASSEMBLY

18. Attach support to each side of frame. (Discard the original self-tapping screws).

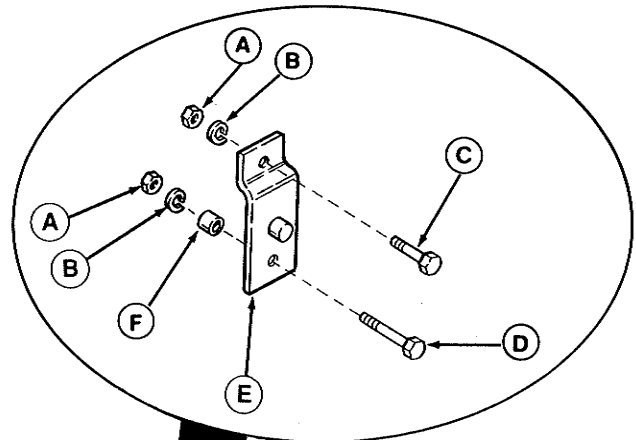
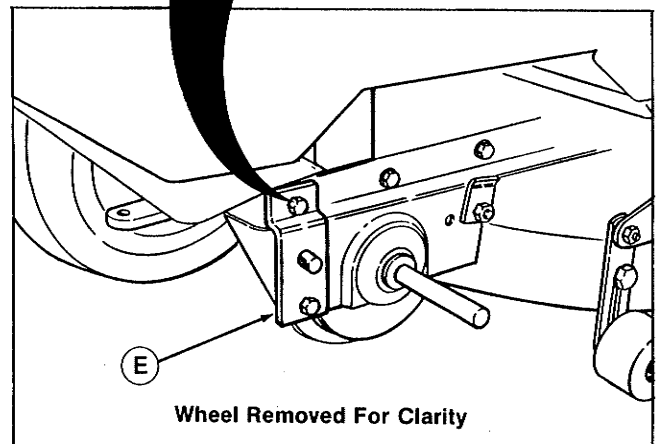

Figure 11.

- A. Nut, 5/16
- B. Lockwasher, 5/16
- C. Capscrew, 5/16 x 1
- D. Capscrew, 5/16 x 1-1/2
- E. Support
- F. Spacer



19. Assemble the side plates (A, figure 12) to the drawbar (B) support with four 5/16-18 x 3/4" flange capscrews (C), lockwashers (D), and nuts (E). Leave hardware loose until after drawbar is installed to frame supports.

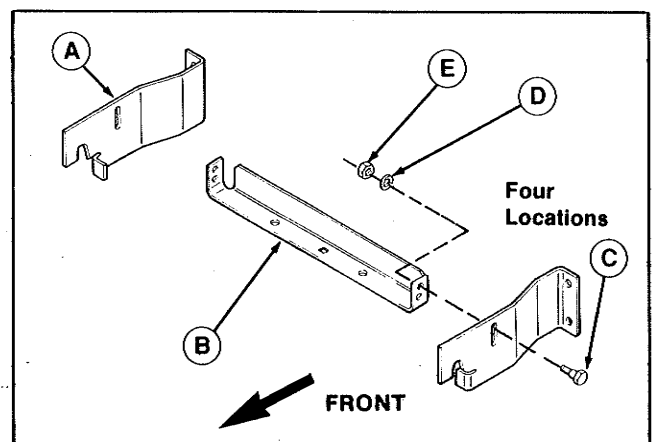

Figure 12.

- A. Side Plate
- B. Drawbar Support
- C. Flange Capscrews, 5/16-18 x 3/4"
- D. Lockwasher
- E. Nut

20. Align the four middle holes of rear (horizontal) support (A, figure 13) onto back plate (B) and vertical support (C). Install four 3/8-16 x 1" capscrews (D, from rear) and secure with lockwashers (E) and nuts (F). Leave hardware loose.

NOTE

Decal should face toward front of rider.

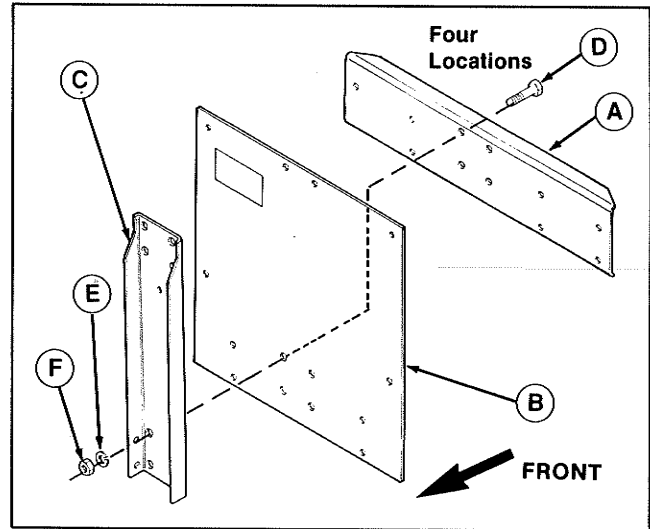

Figure 13.

- A. Horizontal Support
- B. Back Plate
- C. Vertical Support
- D. Capscrew, 3/8-16 x 1"
- E. Lockwasher
- F. Nut

21. Slide heat shield (A, figure 14) over top of vertical support (B) and align holes with back plate (C). At left side, install 5/16-18 x 5/8" capscrew (D, from rear) and secure with lockwasher (E) and nut (F).

22. On right hand side, install vertical heat shield (G, figure 14) between back plate (C) and horizontal heat shield (A). Align the holes between the three plates and install 5/16-18 x 5/8" capscrew (D), lockwasher (E), and nut (F). All top holes in plates and vertical support (B) must be aligned before tightening hardware.

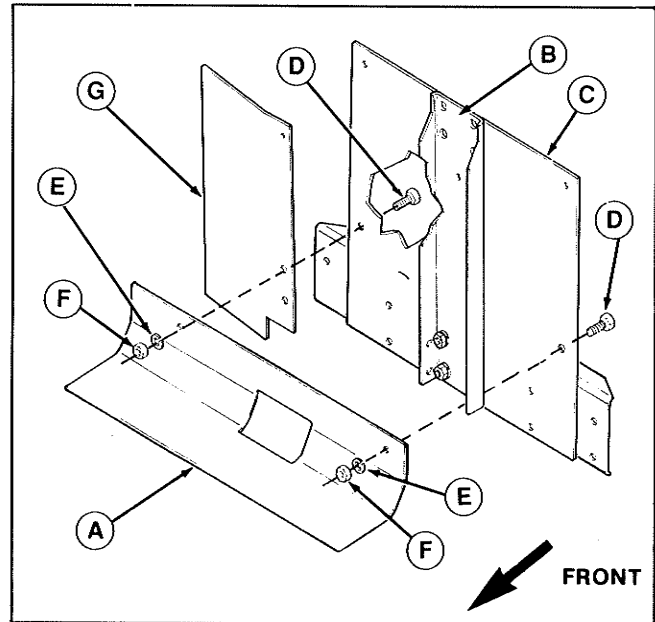

Figure 14.

- A. Heat Shield
- B. Vertical Support
- C. Back Plate
- D. Capscrew, 5/16-18 x 5/8"
- E. Lockwasher
- F. Nut
- G. Heat Shield

23. The drawbar bracket is assembled to the rear support/back plate/heatshield assembly according to mower deck application.
- For 36" mowers, use the outside left hand holes and the inside right hand holes for capscrew location. Refer to figure 15.
 - For 30" mowers, use the outside right hand holes and inside left hand holes for capscrew location. Refer to figure 16.
 - Assemble drawbar to rear support assembly with four 5/16-18 x 3/4" capscrews (A, figure 15 or 16), lockwashers (B), and nuts (C).

- At inside hole location not used, install 5/16-18 x 5/8" capscrews (D) through rear support and back plate. Secure with lockwashers (E) and nuts (F).
 - Tighten all hardware.
24. Install assembled drawbar/rear support to frame supports. Install 5/16-18 x 1" carriage bolt through drawbar support and rider drawbar and secure with wingnut. Tighten wingnut. Make sure that slots in side brackets fit snug over support pins. With side brackets seated correctly, tighten four capscrews.

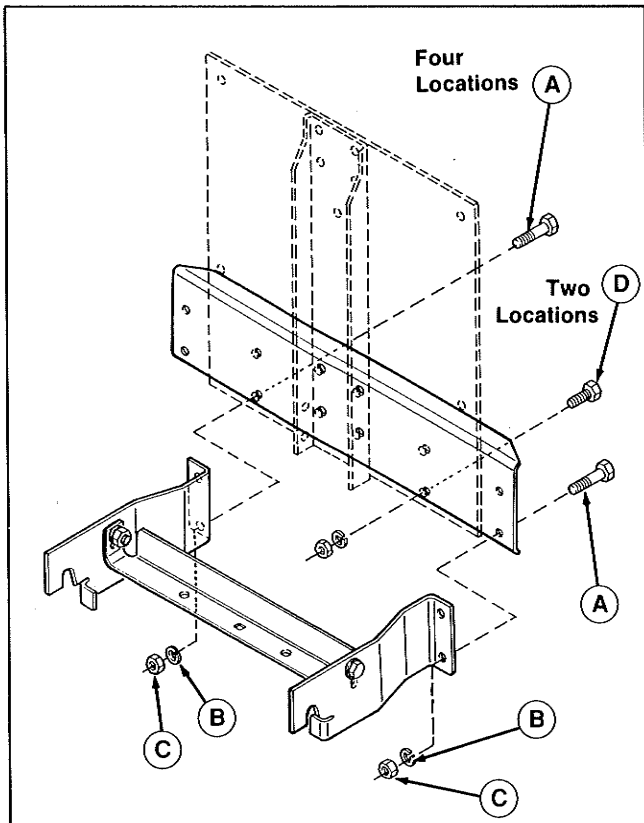

Figure 15. 36" Deck

- A. Capscrew, 5/16-18 x 3/4"
- B. Lockwasher
- C. Nut
- D. Capscrew, 5/16-18 x 5/8"
- E. Lockwasher
- F. Nut

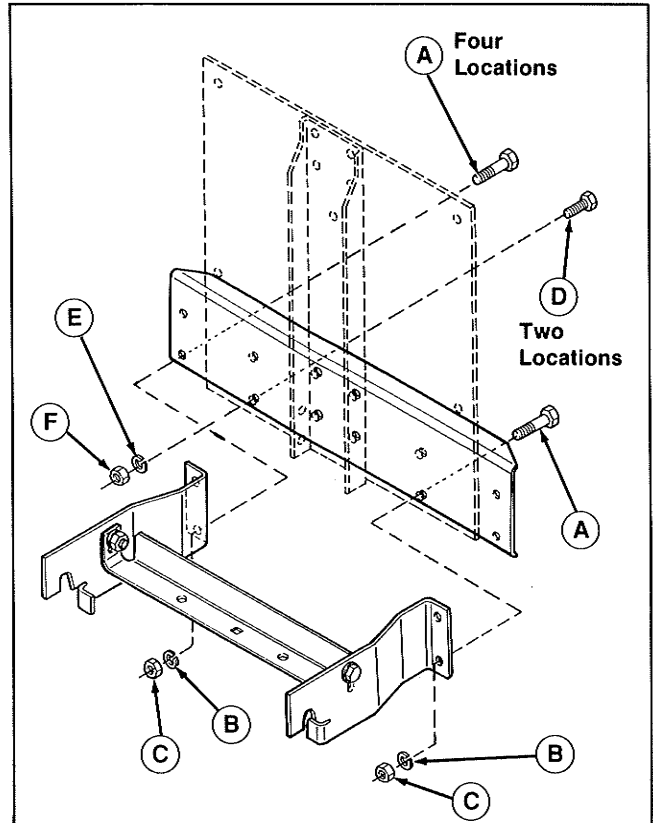

Figure 16. 30" Deck

- A. Capscrew, 5/16-18 x 3/4"
- B. Lockwasher
- C. Nut
- D. Capscrew, 5/16-18 x 5/8"
- E. Lockwasher
- F. Nut

GRASS CATCHER ASSEMBLY

NOTE

Cover and bag support are packaged as an assembly with long clevis pins and clips. It may be easier to separate components for the following step.

25. Install horizontal bag support (A, figure 17) to upright (B) with four 3/8-16 x 7/8" capscrews (C, from front) and flange locknuts. Install 5/16 x 3/8" taptite screws (from front) into top holes in heat shield and bag support (E). Tighten taptite screws securely. Tighten capscrews (C) when upright and support are square. Note that the open set of holes (D) is toward the discharge side of mower.

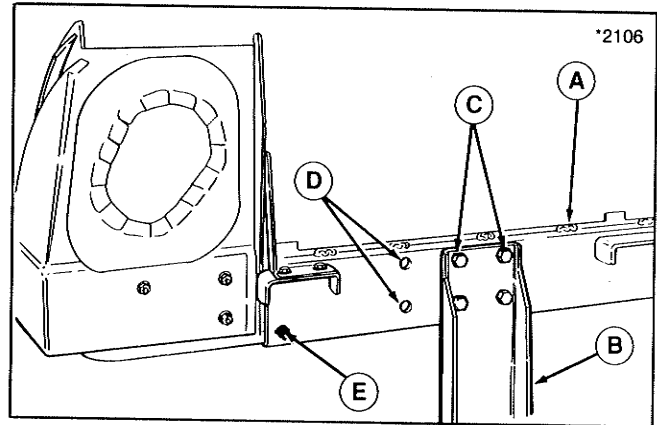

Figure 17.

- A. Bag Support
B. Upright
C. Capscrews, 3/8-16 x 7/8
D. Open Set of Holes
E. Taptite Hole

26. Reinstall grass catcher cover (A, figure 18) to support (B) and secure with clevis pins (C) and clips (D).

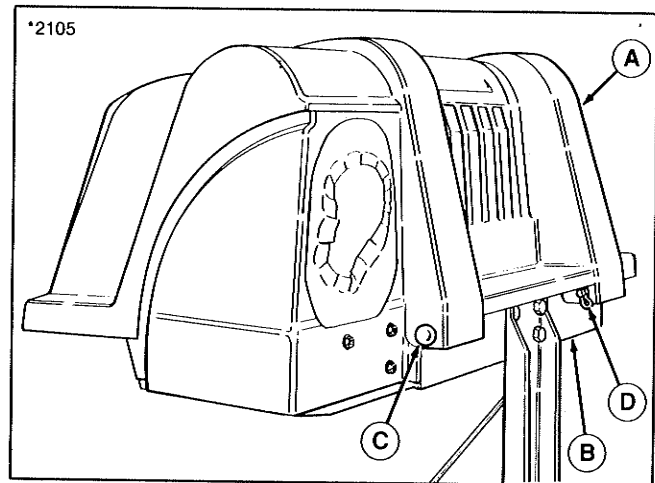

Figure 18.

- A. Cover
B. Support
C. Clevis Pin
D. Clip

27. Install handle (A, figure 19) to rear surface of lid with offset toward the rear. Secure with two 10-32 x 1/2 truss screws (B) and 10-32 nut/washer assemblies (C).

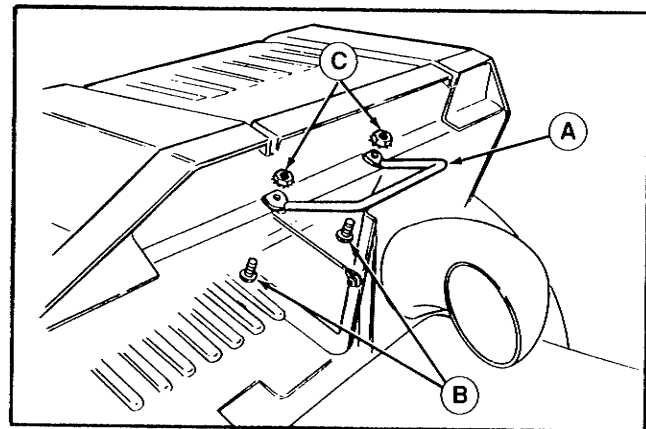

Figure 19.

- A. Handle
B. Truss Screw
C. Nut/Washer Assembly

28. Open cover and fasten cable (A, figure 20) to tube support (B) to prevent cover from going overcenter when opened. Loop end of cable fits over washer (C).

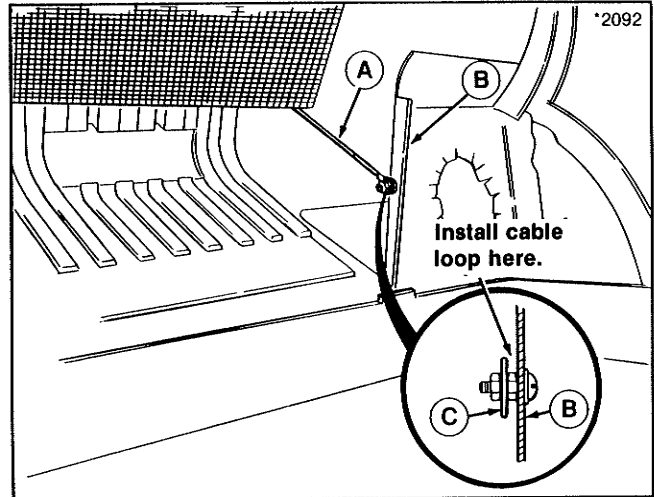

Figure 20.
A. Cable
B. Support
C. Washer

29. Open grass bag cover and install grass bag frames (A, figure 21) to support brackets (B). Make sure cover handle latches to grass bag frames.

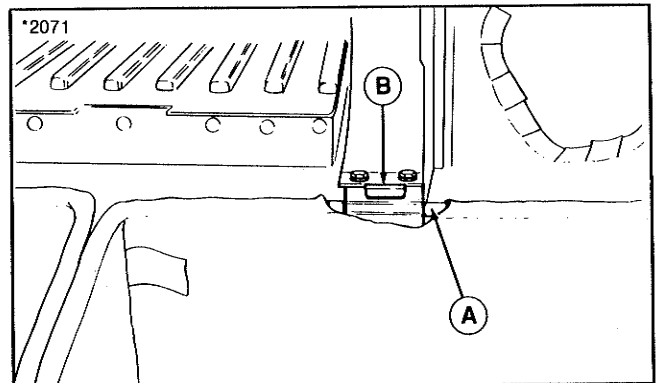

Figure 21.
A. Grass Bag Frame
B. Support Frame

30. Apply dry talc powder to rubber seal at cover opening. Install tube (A, figure 22) as far as possible into opening to clear adapter and install over adapter.

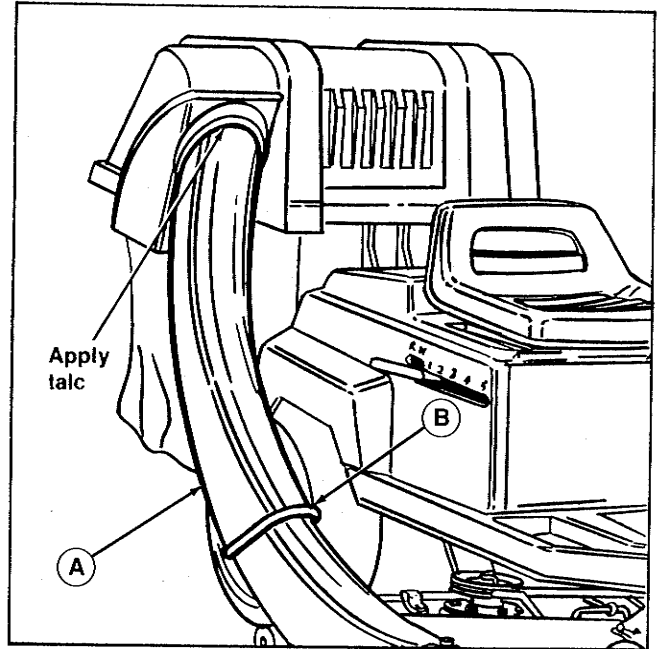

Figure 22.
 A. Tube
 B. Wire Form Location

31. Secure tube by moving wire form (A, figure 23) down over round cup (B) on adapter surface.

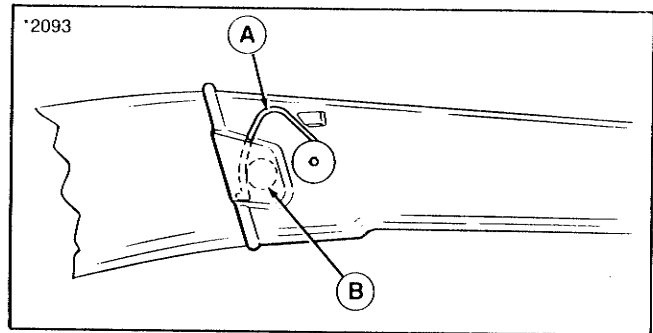

Figure 23.
 A. Wire Form
 B. Round Cup

COUNTERWEIGHT ASSEMBLY

32. The counterweight must be filled with wet sand. To do this, remove the plug (D). Fill the counterweight with sand and add water till full. Reinstall the plug. The counterweight should weight at least 20 lbs. There are two holes in the front frame. Use hardware shown to install counterweight to frame. Do not overtighten bolts.

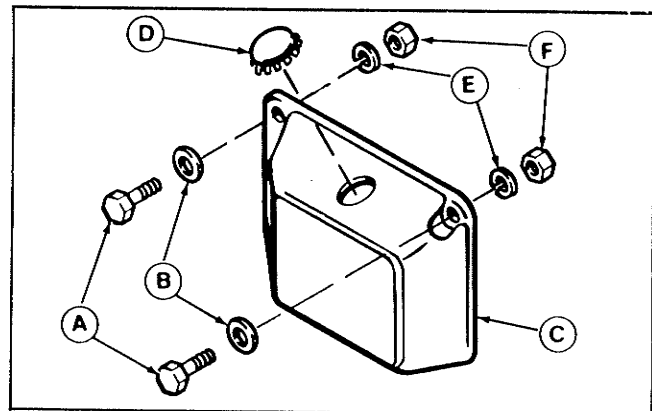

Figure 24.
 A. Capscrew, 5/16-18 x 1
 B. Washer, 11/32 x 1
 C. Counterweight
 D. Plug
 E. Lockwashers, 5/16
 F. Nut, 5/16

Operation and Storage



WARNING

For safety reasons grass and debris are to be removed only after engine is shut off, key removed, and all moving parts stopped.



WARNING

Before raising cover, shut off engine, remove key, and set parking brake.

BEFORE OPERATION

Clear the lawn of all sticks, stones, wire and other debris which may be caught or thrown by the mower blades.

Clean the tube with mild detergent (other products may damage tube). Inspection windows can be removed to be cleaned. Make sure windows are securely in place before operating.

Check grass condition. If wet, wait until later in the day. If grass is wet plugging may occur.

For efficient bagging air circulation under the mower deck, through the chute and into the bag is very important. For this reason, you should remove grass and debris from underside of mower deck, discharge chute and screen inside cover.

The adapter and tube can be removed for cleaning. Remove the nuts and washers that hold the adapter to mower deck and unhook the latch securing tube to adapter.

If desired, the bags can be lined with 30 gallon trash bags for easy disposal.

OPERATION

Grass should be cut often, and not too short. If grass is too long or lush it may be necessary to keep ground speed to a minimum or to cut only half the width to prevent clogging. If grass is high, operate with mower in high cutting position. Cut the grass again in lower cutting position, if desired.

Always operate with throttle at full speed.

EMPTYING THE BAGS

Raise the cover. If a plastic liner was not used, unhook the bag and turn upside down to empty (use handle on bottom).

If plastic liner was used, first tie up top of liner. Then, either pull the liner out, or, turn the bag upside down and allow the filled liner to slide out.

REMOVAL

If grass catcher is removed, original deflector must be installed on 36" mower. Blade and baffles can be left installed on mower deck. Follow these steps to remove grass collection system:

1. Remove adapter from mower deck. For 30" mowers, refer to step 8, page 4. For 36" mower, refer to step 17, page 7.
2. Remove the tube from the adapter and cover (refer to step 30, page 13).
3. Remove the grass bags from support frame (refer to step 29, page 12.)
4. Remove the cover from the support frame (refer to step 26, page 11).
5. To remove the support frame assembly from the frame spacers, remove wing nut and carriage bolt from drawbar (refer to step 24, page 10). Hardware securing rear support bracket to drawbar plates may need to be loosened in order to remove support assembly.
6. On 36" mower, reinstall deflector over carriage bolts and secure with original hardware (refer to step 9, page 5).

STORAGE

1. Clean the grass catcher thoroughly.
2. If paint has been scratched on metal parts, coat with paint or oil.
3. Store in a dry area. Hang the bags to dry. Always store away from moisture.

Troubleshooting

This section provides troubleshooting instructions for the more common and easily corrected problems. See Table 1. For problems not covered, see your dealer.



WARNING

To avoid serious injury, perform maintenance on the grass catcher only after stopping the rider engine and waiting for all moving parts to come to a complete stop. Always remove the ignition key before beginning the maintenance to prevent accidental starting of the engine. Disconnect the spark plug wire and fasten away from plug.

Problem	Cause/Remedy
<p>1. Leaves and grass not being completely picked up.</p>	<ul style="list-style-type: none"> A. Engine speed too slow. Run at full throttle. B. Ground speed too fast. Use lower speed. C. Mower drive belt slipping. Increase belt tension per rider Operator's Manual. D. Discharge tube plugged. Stop engine and remove key. Then remove and unplug discharge tube. E. Using wrong mower blades. See Setup Instructions. F. Blades not tight. Torque to 50-70 ft. lbs. (68-76 Nm). G. Mower not level. See Operator's Manual to level.
<p>2. Grass catcher discharge tube or mower plugs easily.</p>	<ul style="list-style-type: none"> A. Bags full. Empty bags. B. Grass too high. Reduce rider ground speed, reduce cutting width or raise mower adjustment for the first pass, lower it for the second pass. C. Grass or leaves too wet. Wait for drier conditions. D. Build-up of cut grass in mower or adapter. Clean thoroughly. E. Screen in grass bag clogged. Remove cover and clean screens. F. Using wrong mower blades. See Setup Instructions.

Table 1. Troubleshooting

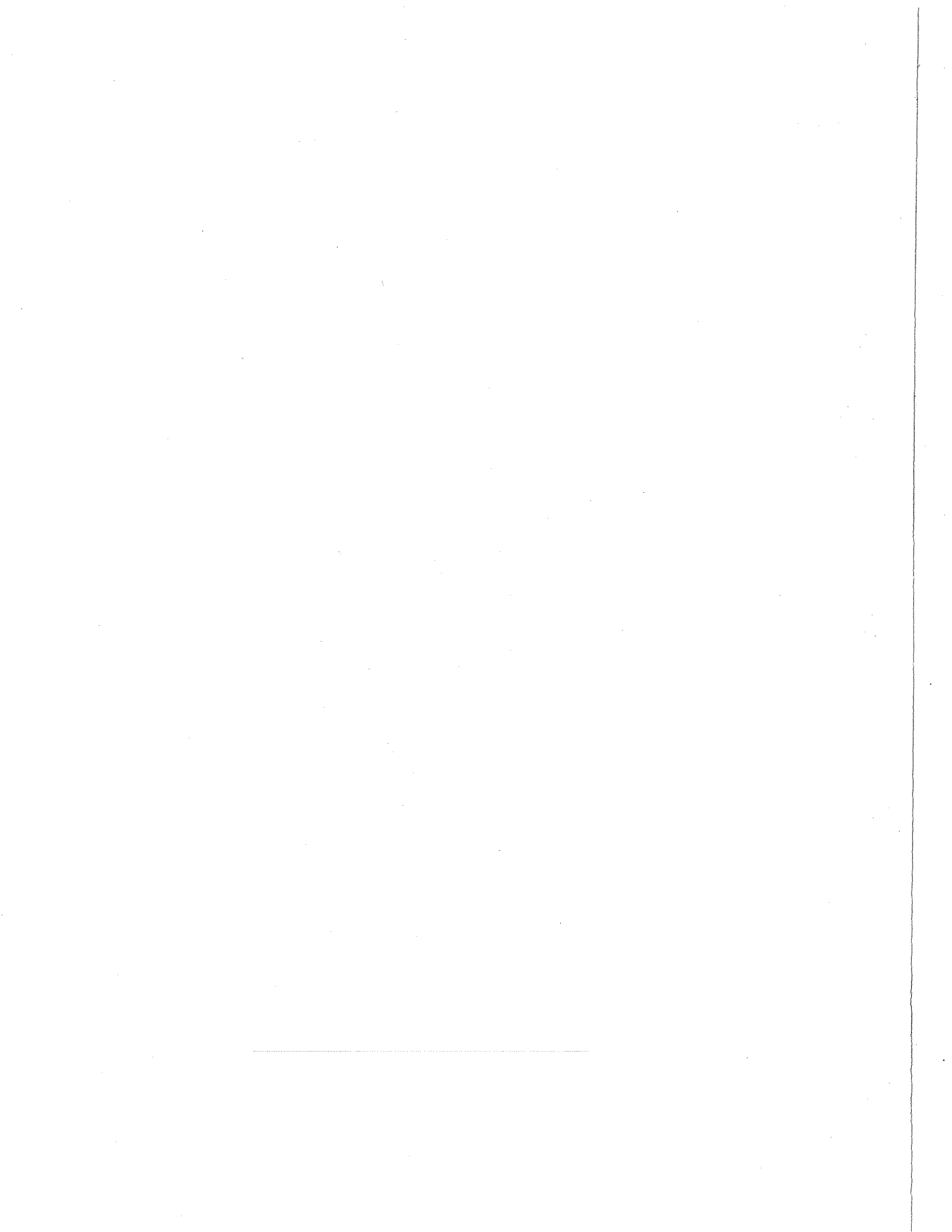

Supplement to Operator's Manual

*Twin Bag Grass Catcher
for Rear-Engine Rider*

Mfg. No. 1691789 - 30" Mower

1. Decal Installation - Refer to figure 1

After assembling the heat shields, the enclosed "Warning - Hot Surfaces" decal must be applied to the front surface (facing the operator) as shown in figure 1 (approximately 1 1/2" down from top of shield and 1/12" from upright support).

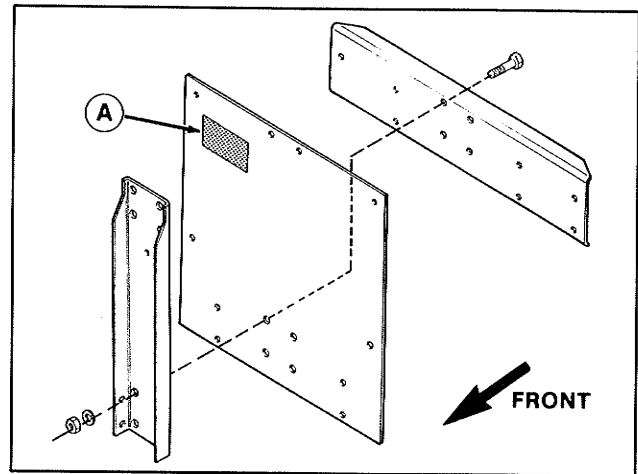

Figure 1. Decal Installation

a. Decal

2. Adapter Installation - Refer to figure 2

a. Page 3, Step 4: In rear hole of mower deck, install 5/16-18 x 1 1/4" carriage bolt provided (rather than 3/4" carriage bolt) and secure with 5/16" jam nut.

b. Page 4, Step 8: Place adapter over rear carriage bolt and secure with knob provided (P/N 1670578). Position front slot between mower deck and wing nut and tighten the wing nut and knob.

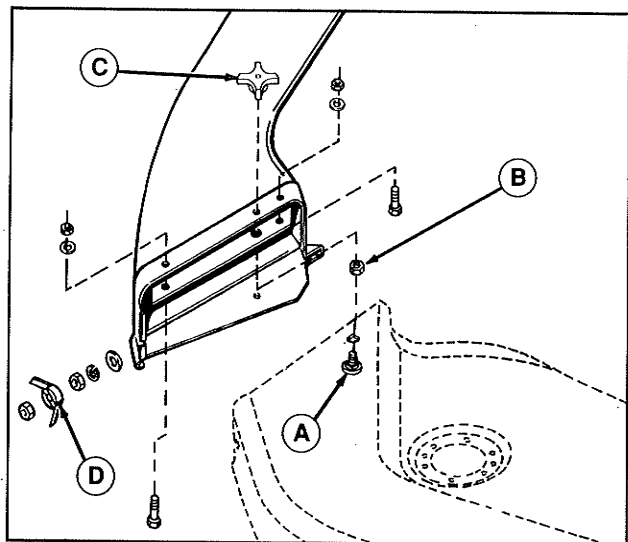
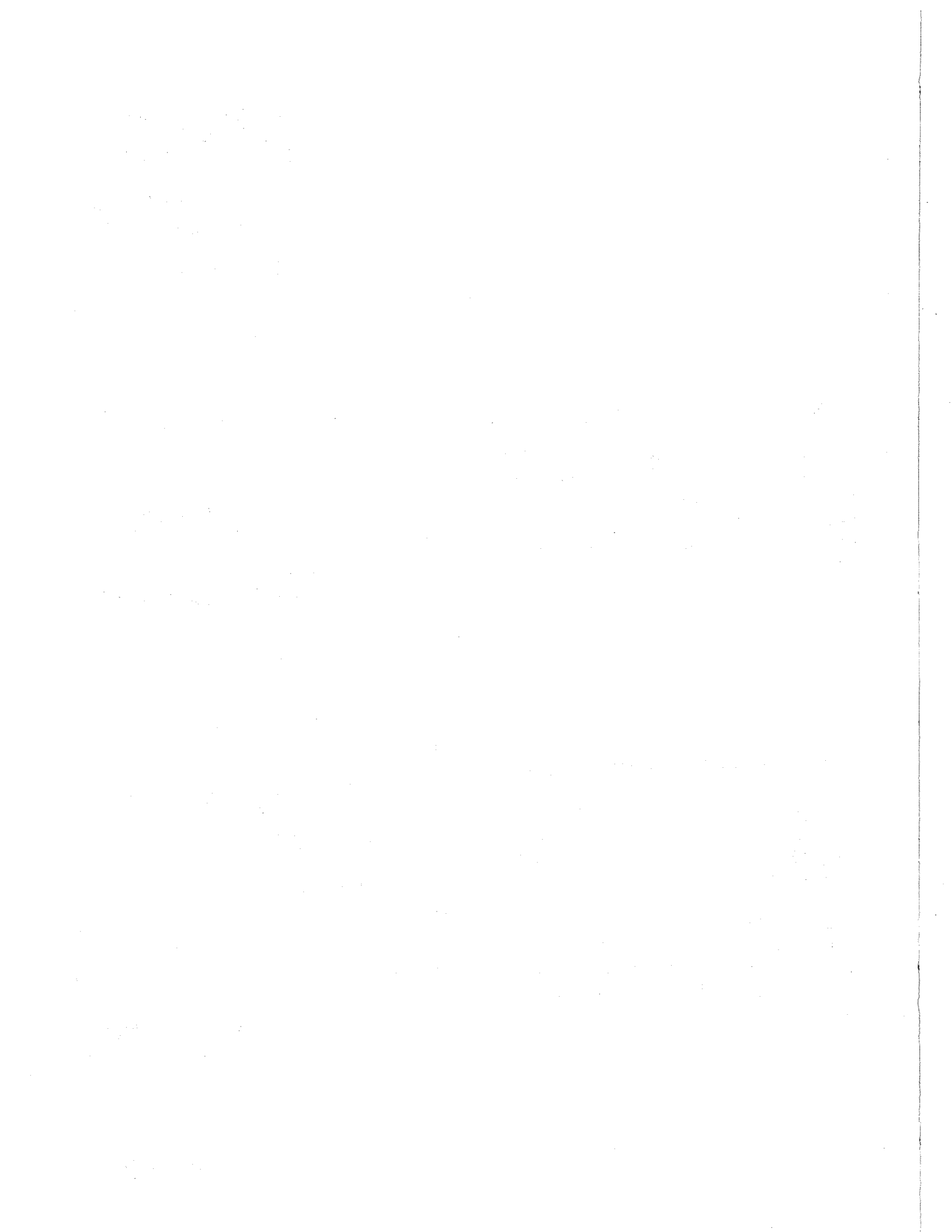





Figure 2. Adapter Installation

- a. Carriage Bolt, 5/16-18 x 1 1/4"
- b. Jam Nut
- c. Knob
- d. Wing Nut



**TORQUE SPECIFICATIONS FOR
STANDARD MACHINE HARDWARE
TOLERANCE $\pm 20\%$**

SIZE	SAE GRADE #2 		SAE GRADE #5 		SAE GRADE #8 	
8-32	19	In. Lbs.	30	In. Lbs.	41	In. Lbs.
8-36	20	"	31	"	43	"
10-24	27	"	43	"	60	"
10-32	31	"	49	"	68	"
1/4-20	66	"	8	Ft. Lbs	12	Ft. Lbs.
1/4-28	76	"	10	"	14	"
5/16-18	11	Ft. Lbs	17	"	25	"
5/16-24	12	"	19	"	25	"
3/8-16	20	"	30	"	45	"
3/8-24	23	"	35	"	50	"
7/16-14	30	"	50	"	70	"
7/16-20	35	"	55	"	80	"
1/2-13	50	"	75	"	110	"
1/2-20	55	"	90	"	120	"
9/16-12	65	"	110	"	150	"
9/16-18	75	"	120	"	170	"
5/8-11	90	"	150	"	220	"
5/8-18	100	"	180	"	240	"
3/4-10	160	"	260	"	386	"
3/4-16	180	"	300	"	420	"
7/8-9	140	"	400	"	600	"
7/8-14	155	"	440	"	660	"
1-8	220	"	580	"	900	"
1-12	240	"	640	"	1,000	"

NOTE:

1. These torque values are to be used for all *Simplicity* hardware excluding: locknuts, self-tapping screws, thread forming screws, sheet metal screws and socket head setscrews.
2. Recommended seating torque values for locknuts:
 - a. For prevailing torque locknuts - use 65% of grade 5 torques.
 - b. For flange whizlock nuts (and screws) - use 135% of grade 5 torques.
3. Unless otherwise noted on assembly drawings all torque values must meet this specification.

BOLT HEAD MARKING

S.A.E. GRADE:

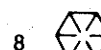
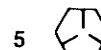
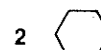

PHOTO

PHOTO