

MASSEY FERGUSON
LAWN & GARDEN EQUIPMENT

OPERATOR'S MANUAL

2800 SERIES

18 HP Hydro
Mfg. No. 1692503
Mfg. No. 1692849

48" Mower Deck
Mfg. No. 1691221

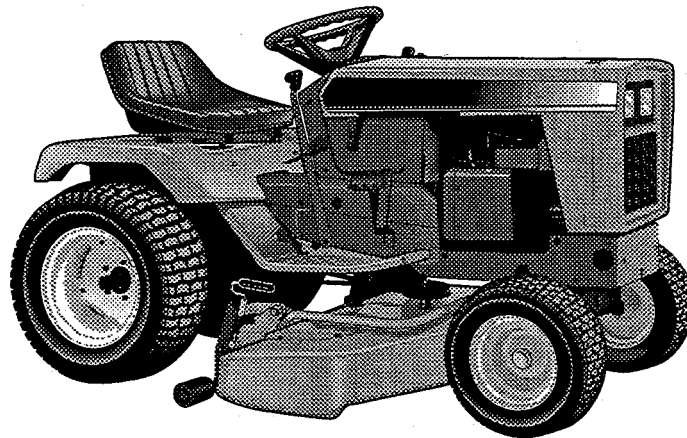

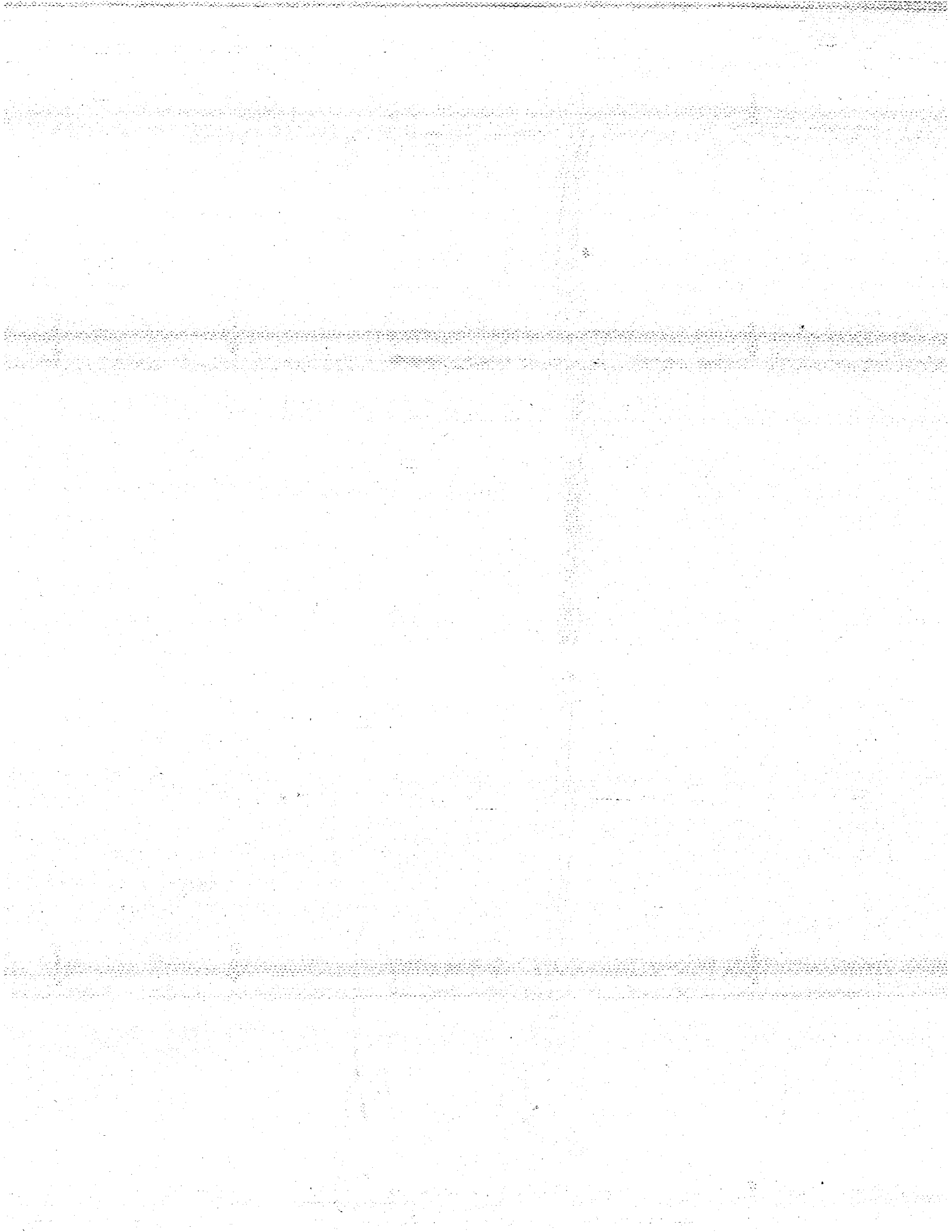



Table Of Contents

| | | | |
|---|----|--|----|
| TRACTOR & MOWER IDENTIFICATION | 2 | Troubleshooting The Tractor | 20 |
| SAFETY RULES | 3 | Troubleshooting The Mower | 21 |
| SAFETY DECALS | 5 | Checking the Battery | 21 |
| FEATURES & CONTROLS | 6 | Charging A Completely Discharged Battery | 22 |
| Tractor Controls | 6 | Jump Starting with Auxiliary (Booster) Battery | 22 |
| Safety Interlock System | 7 | Headlight Bulb Replacement | 23 |
| OPERATION | 8 | ADJUSTMENTS | 24 |
| General | 8 | Seat Adjustment | 24 |
| Mower Installation & Removal | 8 | PTO Clutch Adjustment | 24 |
| Checks Before Starting | 10 | Parking Brake Adjustment | 24 |
| Starting The Engine | 10 | Clutch/Brake Pedal Adjustment | 25 |
| Clutch/Brake Pedal Operation | 10 | Neutral Adjustment | 25 |
| Stopping the Tractor | 11 | Leveling the Mower | 26 |
| Pushing the Tractor by Hand | 11 | Blade Brake Adjustment | 26 |
| MOWING PATTERN & TIPS | 12 | BELT REPLACEMENT | 27 |
| NORMAL CARE | 13 | Tractor Drive Belt | 27 |
| Schedule | 13 | Mower Belt | 27 |
| Raising the Hood | 13 | SPECIFICATIONS | 28 |
| Checking/Adding Gasoline | 13 | PARTS & ACCESSORIES | 29 |
| Checking Tire Pressure | 13 | Common Replacement Parts | 29 |
| Checking the Fuel Filter | 13 | Maintenance Items | 29 |
| Lubrication | 14 | Optional Accessories | 30 |
| Checking Transmission Fluid | 15 | Technical Literature | 30 |
| Changing Transmission Fluid & Filter | 16 | INTERNATIONAL SYMBOLS | 31 |
| Check Bevel Gear Box Fluid | 16 | <i>NOTE: In this manual, "left" and "right" are referred to as seen from the operating position.</i> | |
| Battery Maintenance | 16 | | |
| Servicing the Mower Blades | 17 | | |
| STORAGE | 18 | | |
| Temporary Storage | 18 | | |
| Long Term Storage | 18 | | |
| Starting After Storage | 19 | | |
| TROUBLESHOOTING & REPAIR | 20 | | |
| General | 20 | | |

 WARNING

Engine exhaust from this product contains chemicals known, in certain quantities, to cause cancer, birth defects, or other reproductive harm.

Tractor & Mower Identification

Record your model number, manufacturer number and engine serial number in the space provided for easy reference. The models and manufacturer numbers covered in this manual are listed on the front cover.

The tractor I.D. tag is located on the left-side, front of the frame, as shown below. The mower deck I.D. tag is also on the left side, on top of the mower deck, towards the rear.

| MODEL REFERENCE | |
|-----------------------------|-------|
| Model Number: | _____ |
| Manufacturer Number: | _____ |
| Engine I.D. Number: | _____ |
| Dealer Name/Date Purchased: | _____ |

Refer to the engine Owner's Manual for location of engine serial number.

Be sure to fill out and return the Warranty Registration Card supplied with your tractor.

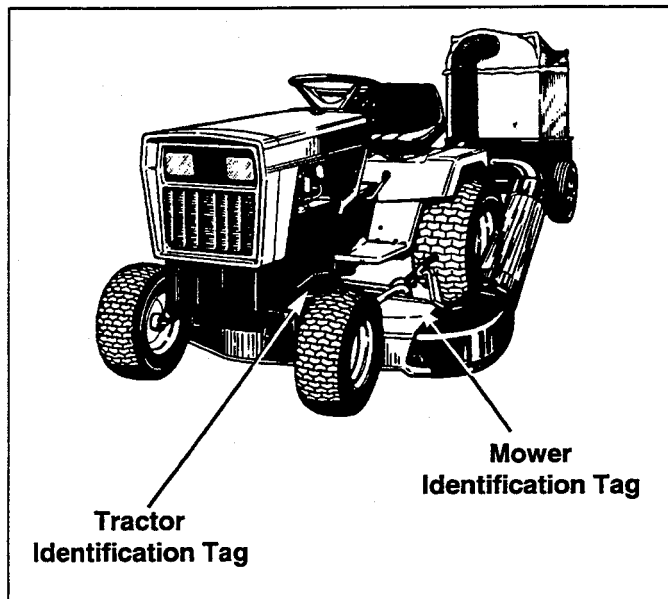



Figure 1. Tractor & Mower Identification Tags



Read these safety rules and follow them closely. Failure to obey these rules could result in loss of control of rider, severe personal injury or death to you, or bystanders, or damage to property or equipment. **This mowing deck is capable of amputating hands and feet and throwing objects.** The triangle  in text signifies important cautions or warnings which must be followed.

GENERAL OPERATION

- Read, understand, and follow all instructions in the manual and on the unit before starting.
- Only allow responsible adults, who are familiar with the instructions, to operate the unit.
- Clear the area of objects such as rocks, toys, wire, etc., which could be picked up and thrown by the blade(s).
- Be sure the area is clear of other people before mowing. Stop unit if anyone enters the area.
- Never carry passengers.
- Do not mow in reverse unless absolutely necessary. Always look down and behind before and while travelling in reverse.
- Be aware of the mower discharge direction and do not point it at anyone. Do not operate the mower without either the entire grass catcher or the deflector in place.
- Slow down before turning.
- Never leave a running unit unattended. Always disengage the PTO, set parking brake, stop engine, and remove keys before dismounting.
- Turn off the PTO to disengage the blades when not mowing.
- Stop engine before removing grass catcher or unclogging chute.
- Mow only in daylight or good artificial light.
- Do not operate the unit while under the influence of alcohol or drugs.
- Watch for traffic when operating near or crossing roadways.
- Use extra care when loading or unloading the unit into a trailer or truck.

SLOPE OPERATION

Slopes are a major factor related to loss-of-control and tip-over accidents, which can result in severe injury or death. All slopes require extra caution. If you cannot back up the slope or if you feel uneasy on it, do not mow it.

WARNING - SLOPE OPERATION

Never operate on slopes greater than 30 percent (16.7°) which is a rise of three feet vertically in 10 feet horizontally. When operating on slopes that are greater than 15 percent (8.5°) but less than 30 percent use front counterweights and rear wheel weights (see your dealer). Select slow ground speed before driving onto slope. In addition to front and rear weights, use extra caution when operating on slopes with rear-mounted grass catcher. Mow UP and DOWN the slope, never across the face, use caution when changing directions and DO NOT START OR STOP ON SLOPE.

Do

- See your authorized dealer for recommendations of wheel weights or counterweights to improve stability.
- Mow up and down slopes, not across.
- Remove obstacles such as rocks, tree limbs, etc.
- Watch for holes, ruts, or bumps. Uneven terrain could overturn the unit. Tall grass can hide obstacles.
- Use slow speed. Choose a low gear so that you will not have to stop or shift while on the slope.
- Use extra care with grass catchers or other attachments. These can change the stability of the unit.
- Keep all movement on the slopes slow and gradual. Do not make sudden changes in speed or direction.

Do Not

- *Do not* start or stop on a slope. If tires lose traction, disengage the blade(s) and proceed slowly straight down the slope.
- *Do not* turn on slopes unless necessary, and then, turn slowly and gradually downhill, if possible.
- *Do not* mow near drop-offs, ditches, or embankments. The mower could suddenly turn over if a wheel is over the edge of a cliff or ditch, or if an edge caves in.
- *Do not* mow on wet grass. Reduced traction could cause sliding.
- *Do not* try to stabilize the unit by putting your foot on the ground.
- *Do not* use grass catcher on steep slopes.

Safety Rules

CHILDREN

Tragic accidents can occur if the operator is not alert to the presence of children. Children are often attracted to the unit and the mowing activity. Never assume that children will remain where you last saw them.

- Keep children out of the mowing area and under the watchful care of another responsible adult.
- Be alert and turn unit off if children enter the area.
- Before and when backing, look behind and down for small children.
- Never carry children. They may fall off and be seriously injured or interfere with safe unit operation.
- Never allow children to operate the unit.
- Use extra care when approaching blind corners, shrubs, trees, or other objects that may obscure vision.

TRANSPORTING AND STORAGE

- Always observe safe refueling and fuel handling practices when refueling the tractor after transportation or storage.
- Always follow the engine manual instructions for storage preparations before storing the tractor for both short and long term periods.
- Always follow the engine manual instructions for proper start-up procedures when returning the unit to service.
- Never store the unit or fuel container inside where there is an open flame or pilot light, such as in a water heater. Allow unit to cool before storing.

SERVICE AND MAINTENANCE

- Use extra care in handling gasoline and other fuels. They are flammable and vapors are explosive.
 - a) Use only an approved container.
 - b) Never remove gas cap or add fuel with the engine

running. Allow engine to cool before refueling. Do not smoke.

c) Never refuel the unit indoors.

- Never run a unit inside an enclosed area.
- Keep nuts and bolts, especially blade attachment bolts, tight and keep equipment in good condition.
- Never tamper with safety devices. Check their proper operation regularly.
- Keep unit free of grass, leaves, or other debris build-up. Clean up oil or fuel spillage.
- Stop and inspect the equipment if you strike an object. Repair, if necessary, before restarting.
- Never make adjustments or repairs with the engine running unless specified otherwise in the engine manufacturer's manual.
- Grass catcher components are subject to wear, damage, and deterioration, which could expose moving parts or allow objects to be thrown. Frequently check components and replace with manufacturer's recommended parts, when necessary.
- Mower blades are sharp and can cut. Wrap the blade(s) or wear gloves, and use extra caution when servicing them.
- Check brake operation frequently. Adjust and service as required.
- Use only factory authorized replacement parts when making repairs.
- Always comply with factory specifications on all settings and adjustments.
- Only authorized service locations should be utilized for major service and repair requirements.
- Never attempt to make major repairs on this unit unless you have been properly trained. Improper service procedures can result in hazardous operation, equipment damage and voiding of manufacturer's warranty.

Safety Decals

This unit has been designed and manufactured to provide you with the safety and reliability you would expect from an industry leader in outdoor power equipment manufacturing.

Although reading this manual and the safety instructions it contains will provide you with the necessary basic knowledge to operate this equipment safely and effectively, we have placed several safety labels on the unit to remind you of this important information while you are operating your tractor.

All WARNING, CAUTION and instructional messages on

your tractor and mower should be carefully read and obeyed. Personal bodily injury can result when these instructions are not followed. The information is for your safety and it is important! The safety decals shown below are on your tractor and mower.

If any of these decals are lost or damaged, replace them at once. See your local dealer for replacements.

These labels are easily applied and will act as a constant visual reminder to you, and others who may use the equipment, to follow the safety instructions necessary for safe, effective operation.

CHOKER

LIGHTS

IGNITION SWITCH OFF ON START

WARNING

AVOID SERIOUS INJURY OR DEATH

- READ OPERATOR'S MANUAL(S).
- KNOW LOCATION AND FUNCTION OF ALL CONTROLS.
- KEEP SAFETY DEVICES (GUARDS, SHIELDS, AND SWITCHES) IN PLACE AND WORKING.
- REMOVE OBJECTS THAT COULD BE THROWN BY THE BLADE.
- DO NOT MOW WHEN CHILDREN OR OTHERS ARE AROUND.
- NEVER CARRY CHILDREN.
- LOOK DOWN AND BEHIND BEFORE AND WHILE BACKING.
- AVOID SUDDEN TURNS.
- IF YOU CANNOT BACK UP A HILL, DO NOT OPERATE ON IT.
- GO UP AND DOWN SLOPES, NOT ACROSS.
- IF MACHINE STOPS GOING UPHILL, STOP BLADE AND BACK DOWN SLOWLY.
- BE SURE BLADE(S) AND ENGINE ARE STOPPED BEFORE PLACING HANDS OR FEET NEAR BLADE(S).
- WHEN LEAVING MACHINE, SHUT OFF ENGINE, REMOVE KEY, AND SET PARKING BRAKE.

BRAKE-CLUTCH PEDAL

ENGAGE CLUTCH APPLY BRAKE

PARKING BRAKE LEVER

ON OFF

CAUTION: DO NOT TOW TRACTOR. DAMAGE WILL RESULT TO HYDROSTATIC TRANSMISSION.

↑ CENTER PTO ENGAGE
↓ DISENGAGE

Part No. 1708283

WARNING

DISCONNECT GROUND (-) TERMINAL WHEN WORKING ON ELECTRICAL SYSTEM TO PREVENT SHORT CIRCUIT

Part No. 1676933

DANGER

ROTATING CUTTING BLADE DO NOT PUT HANDS OR FEET UNDER MOWER DECK WHILE BLADE IS ROTATING.

Part No. 1704276

DANGER

ROTATING CUTTING BLADE DO NOT OPERATE MOWER WITHOUT DEFLECTOR OR ENTIRE GRASS CATCHER IN PLACE.

Part No. 1704277

WARNING

TO AVOID INJURY DO NOT RUN ENGINE WITH SEAT DECK RAISED

Part No. 1676934

Features & Controls

TRACTOR CONTROLS

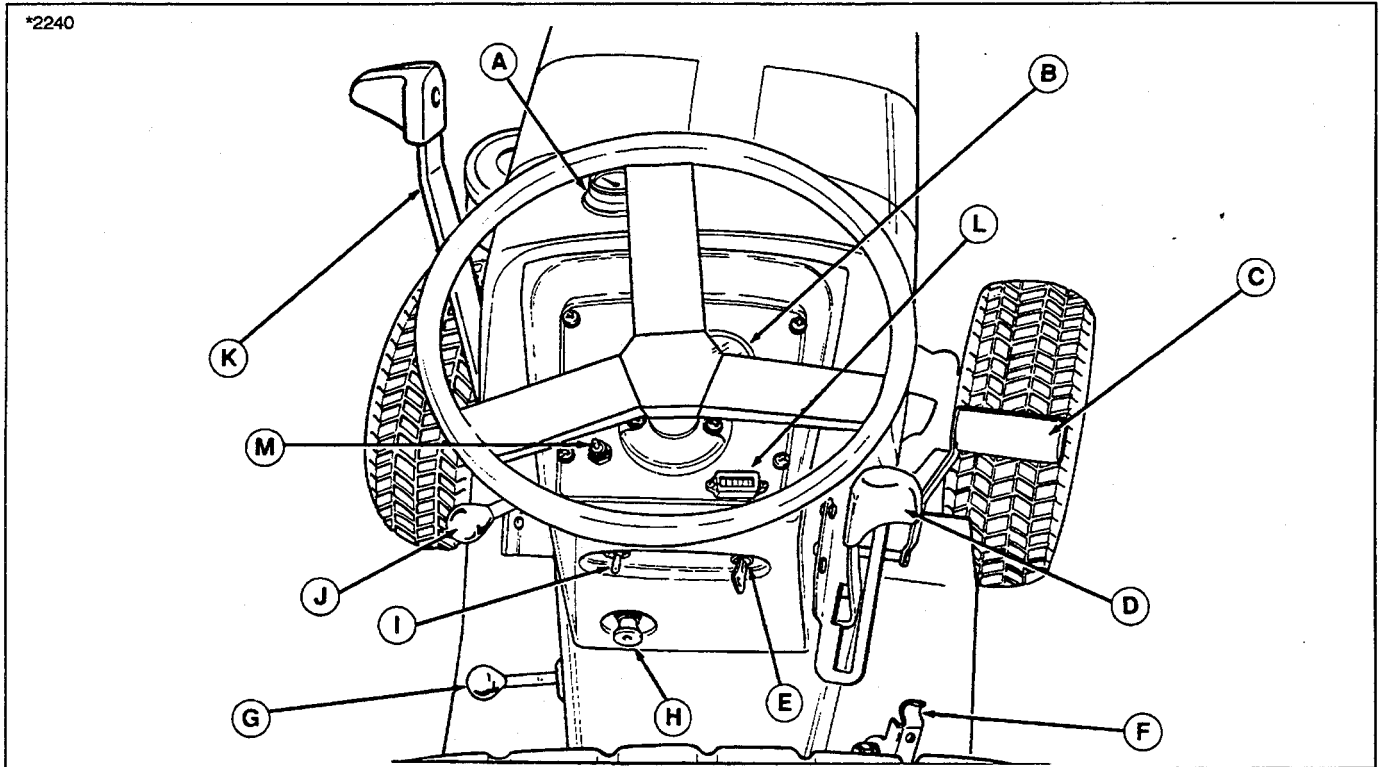

Figure 2. Tractor Controls

| REF | NAME | FUNCTION |
|-----|----------------------------|--|
| A | Gasoline Gauge | Shows gasoline level and serves as a tank cap |
| B | Ammeter | Shows when battery is being charged or discharged. |
| C | Clutch/Brake Pedal | Disengages clutch when depressed at least halfway. Applies brake when fully depressed. |
| D | Ground Speed Control Lever | Controls forward and reverse ground speeds. |
| E | Ignition Switch & Key | Starts and stops engine. |
| F | Parking Brake Lever | Locks brakes to hold tractor in parked position. |
| G | PTO Lever | Engages and disengages power to attachments. |
| H | Choke Knob | When pulled out, closes engine choke for cold weather starting. |
| I | Light Switch | Switches headlights on and off. |
| J | Engine Speed Control | Controls engine speed. |
| K | Hydraulic Lift | Lifts attachments to transport position. |
| L | Hourmeter | Optional accessory to record number of hours engine has run. |
| M | Spout Rotator | Optional accessory used to rotate spout on snowthrower. |

SAFETY INTERLOCK SYSTEM

Your tractor is equipped with a seat switch safety system that will automatically shut the engine off when the operator leaves the seat with the ground speed control lever in gear or with the PTO engaged. Once the engine has stopped, the electric PTO switch must be turned off after operator returns to the seat in order to start the engine.

Check the seat switch (A, figure 3) every fall and spring with the following four tests:

Test 1 - Engine should NOT crank if:

- A. seat is not occupied or
- B. ground speed control lever out of neutral or
- C. PTO lever is engaged.

Test 2 - Engine should crank if:

- A. seat is occupied and
- B. ground speed control lever is in neutral and
- C. PTO lever is disengaged.

Test 3 - Engine should shut off if:

- A. operator rises off seat with ground speed control lever in gear.
- B. operator rises off seat with PTO engaged.

NOTE: If operator returns to seat before engine stops, the engine will re-start and PTO clutch will re-engage.

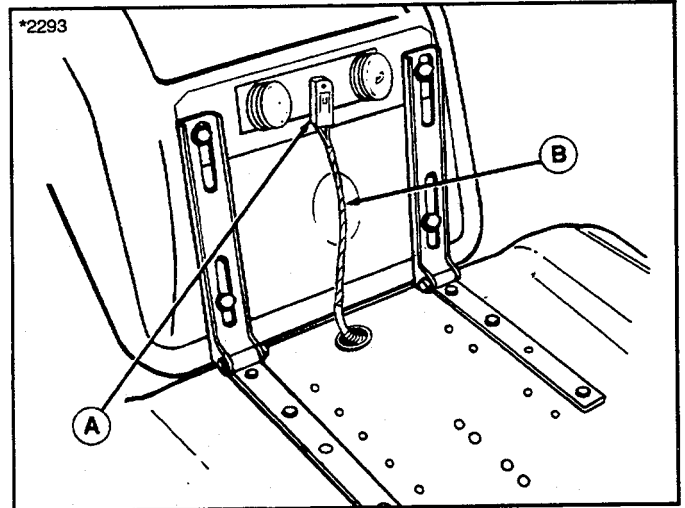

Figure 3. Seat Switch

A. Switch

B. Wiring Harness

Test 4 - PTO will disengage if:

- A. operator rises off seat with engine running.

NOTE: If operator returns to seat before engine stops, the engine will re-start and PTO clutch will re-engage.

⚠ WARNING

If the tractor does not pass the test, do not operate tractor. See your authorized dealer. Under no circumstances should you attempt to defeat the purpose of the safety system.

Operation

GENERAL

Before operating this tractor for the first time, the owner should operate in an open area without mowing, to become accustomed to the unit. The right side of the mower can be used to trim close to objects. Be sure to read all information in the Safety and Operation sections before attempting to operate this tractor and mower.

⚠ WARNING - SLOPE OPERATION

Never operate on slopes greater than 30 percent (16.7°) which is a rise of three feet vertically in 10 feet horizontally. When operating on slopes that are greater than 15 percent (8.5°) but less than 30 percent use front counterweights and rear wheel weights (see your dealer). Select slow ground speed before driving onto slope. In addition to front and rear weights, use extra caution when operating on slopes with rear-mounted grass catcher. Mow UP and DOWN the slope, never across the face, use caution when changing directions and DO NOT START OR STOP ON SLOPE.

⚠ WARNING

Never allow passengers to ride on the unit.

⚠ CAUTION

Towing the tractor will cause transmission damage. Do not use another vehicle to push or pull tractor.

⚠ WARNING

The interlock safety switches are for your safety. Do not attempt to bypass them.

⚠ WARNING

To reduce fire hazard, keep the engine and mower free of grass, leaves and excess grease.

⚠ CAUTION

Do not attempt to move the ground speed control lever when the parking brake is engaged or the service brakes are being applied. Equipment damage will occur.

MOWER INSTALLATION

⚠ WARNING

It will be necessary to start the engine to raise or lower the lift cable. Before starting the engine, always seat yourself in the operator's position. Before leaving the operator's position, stop engine and remove key. Do not engage PTO until mower is completely installed and operator is seated.

NOTE: Perform mower installation on a hard, level surface such as a concrete floor.

Refer to figure 4.

1. Park the tractor to the right of the mower and turn the tractor front wheels fully to the right.
2. Make sure the front idler pulley (L) is installed in top mounting tab for mower installation. Bottom mounting tab is used for snowthrower operation.
3. Start the engine. With ground speed control lever in NEUTRAL, release the clutch/brake pedal. Push the lift lever forward to lower the cable. Shut off the engine.
4. Reach under the tractor to grasp the lift cable and pull it straight down. The lift cable will not lower without weight on it.
5. Slide the mower under the tractor, then turn the front wheels to face straight ahead. Use the lift cable pin and spring clip to attach the tractor lift cable clevis (F,) to the mower lift anchor (E). Use the lower hole on top lift cable clevis (not shown) for a higher transport position.
6. Start the engine and raise the mower halfway using the lift lever. Be sure to shut off tractor engine before leaving the seat.
7. Lift the front of the mower and attach the mower hitch arms (I) to the tractor hitch (J) using two pins and safety clips. Install the pins from the outside. It is easier to install the left-hand pin first.
8. Lower the mower fully using the lift lever.
9. Push the belt tensioning lever (C) fully down and forward.
10. Raise the tractor seat to gain access to the PTO pulley.
11. Install the mower drive belt on the mower pulley and tractor pulleys. The belt must be seated in the inner groove of the drive pulley (B). Make sure that flat side of the belt contacts the front idler pulley (L).
12. Pull the belt tensioning lever (C) fully back and up to put tension on the mower drive belt.
13. When installing belt, the rear edge of the idler bracket

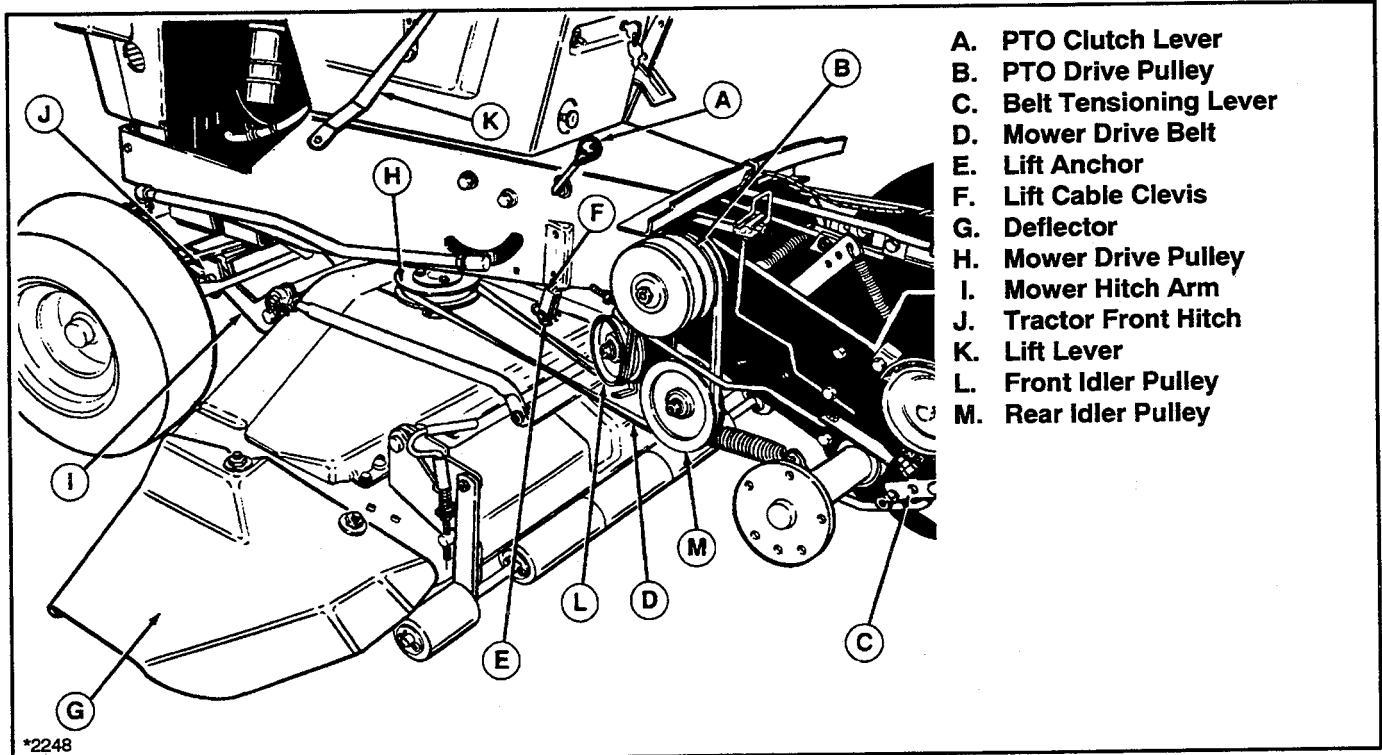

*2248

Figure 4. Mower Installation & Removal

(A, figure 5) should be aligned with the front edge of the green zone shown in figure 5. The distance between idler bracket (A) and stop (C) will be approximately 1-3/16" (30 mm).

14. Push the belt tensioning lever down to release belt tension. Loosen the nut that secures the rear idler pulley (D, figure 5) in the slot. To move the idler bracket (A) forward, move rear idler pulley (D) rearward. Tighten the nut to secure pulley. Pull the belt tensioning lever up and check position of idler bracket (A). Readjust as necessary.
15. Operate the tractor with mower engaged for 15 - 30 minutes with a new belt; about two minutes with a used belt. Disengage the PTO, stop the engine, remove the key, shift into neutral and set the parking brake. Check position of the idler bracket (A, figure 5). If the rear edge of the bracket is not aligned with front edge of green zone, repeat step 14.

Check adjustment periodically. If rear edge of idler bracket moves into red, repeat step 14.

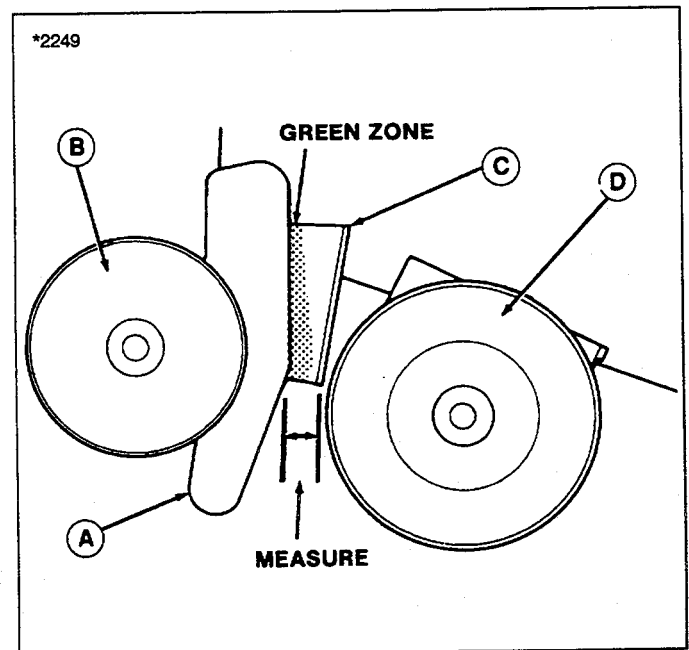

Figure 5. Mower Belt Adjustment

Operation

16. If a new belt or mower was installed, level the mower as described in the Adjustments section.

NOTE: Check belt adjustment periodically during mower season. Drive belt must be readjusted when rear edge of idler bracket aligns with rear edge of green zone or goes into the red zone.

MOWER REMOVAL

WARNING

It will be necessary to start the engine to raise or lower the lift cable. Before starting the engine, always seat yourself in the operator's position. Before leaving the operator's position, stop engine, remove key disengage power to attachments and set the parking brake.

NOTE: Perform mower removal on a hard, level surface such as a concrete floor. Make sure there is room on the left side of tractor to remove mower.

Refer to figure 4.

1. Push the belt tensioning lever (C) fully down and forward to release mower belt tension.
2. Raise the tractor seat deck and remove the mower drive belt from the mower and tractor pulleys. Close the seat deck.
3. Use the tractor lift lever to raise the mower halfway.
4. Remove the safety clips and pins to detach the mower hitch from the tractor hitch. Remove the right-hand side pin first. Reinstall the pins and safety clips in the mower hitch for storage.
5. Lower mower fully.
6. Remove the spring clip and pin to detach the lift cable from the mower. Reinstall the pin and spring clip in the lift cable for storage.
7. Turn tractor wheels fully right and slide the mower out the left side.
8. Pull the belt tensioning lever fully back and up out of the way to prevent damaging it when using the tractor without the mower.

CHECKS BEFORE STARTING

1. Make sure you have proper wheel or counterweights if required. See SLOPE OPERATION in the Safety Rules section. Make sure any slopes are within required limits.
2. Check that crankcase is filled to full mark on dipstick. See the engine Operator's Manual for instructions and oil recommendations.

3. Make sure all nuts, bolts, screws and pins are in place and tight.
4. Make sure you can reach all controls from operator's positions. If not, see SEAT ADJUSTMENT.
5. Fill the gasoline tank with fresh gasoline. Fill to bottom of filler neck to avoid spillage and overflow. **DO NOT** mix oil with gasoline. Refer to engine manual for gasoline recommendations.

WARNING

Gasoline is highly flammable and must be handled with care. Never fill the tank when the engine is still hot from recent operation. Do not allow open flame, smoking or matches in the area. Avoid over-filling and wipe up any spills.

CLUTCH/BRAKE PEDAL OPERATION

1. See figure 6. Depressing the pedal from position A to B disengages transmission drive belt and applies tractor brake.
2. To apply the parking brake pull up on the parking brake lever (F, figure 2).

STARTING THE ENGINE

Refer to figure 2.

1. Operator must be seated.
2. Place ground speed control lever (D) in neutral. Set parking brake. To set, depress pedal, pull parking brake lever (F) up, then release pedals.
3. PTO lever (G) must be in OFF position.
4. On a cold engine, pull out choke knob (H). On a warm engine, push choke knob in.
5. Place engine speed control (J) midway between slow and fast (Start/Stop position).
6. Turn key (E) to start engine. Push choke in as engine warms up.
7. Allow engine to warm up for a couple of minutes before applying load. Do not idle engine for prolonged periods or carbon buildup may occur.

WARNING

Make sure desired direction of travel is clear of objects, people and animals.

OPERATION

Refer to figure 2.

1. Push parking brake lever down to release parking brake.
2. Move ground speed control lever (D) to forward or reverse to start into motion. The farther lever is moved, the faster the ground speed. Place throttle lever in forward (fast) position.
3. Push the hydraulic lift lever (K) forward to lower the attachment. Pull lever back to raise the attachment.
4. Use the PTO lever (G) to engage or disengage the attachment..

STOPPING THE TRACTOR

Refer to figure 2.

1. Move ground speed control lever (D) to neutral and depress brake pedal.
2. Switch PTO to off.
3. Move throttle midway between slow and fast position before shutting off engine.
4. To set parking brake depress brake pedal and pull parking brake lever (F) up.
5. Push hydraulic lift lever forward to lower attachment.
6. Turn ignition off and remove key to prevent unauthorized use.

WARNING

Before leaving operator's position for any reason, engage the parking brake, disengage the PTO(s), stop the engine and remove the key.

PUSHING THE TRACTOR BY HAND

1. To push tractor by hand, the release lever (A, figure 7) must be engaged (pushed all the way down). Do not push the tractor with the engine running.
2. To drive the tractor, the release lever must be pulled all the way up.

WARNING

Do not tow the tractor. Damage will result to the transmission/transaxle.

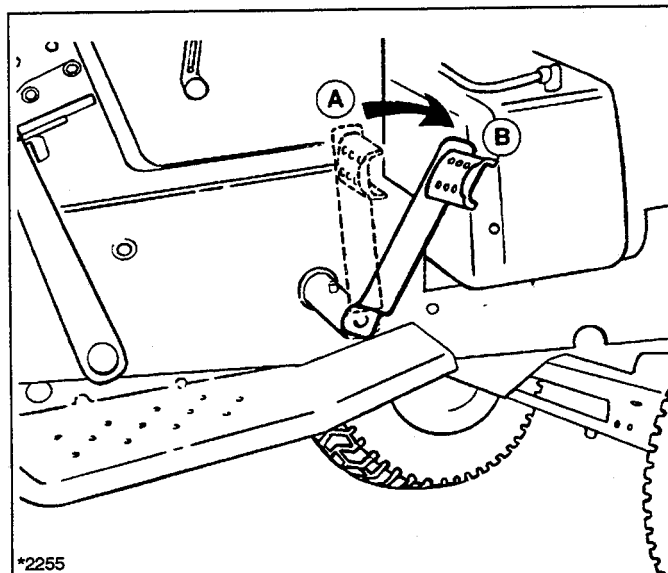

Figure 6. Clutch/Brake Pedal

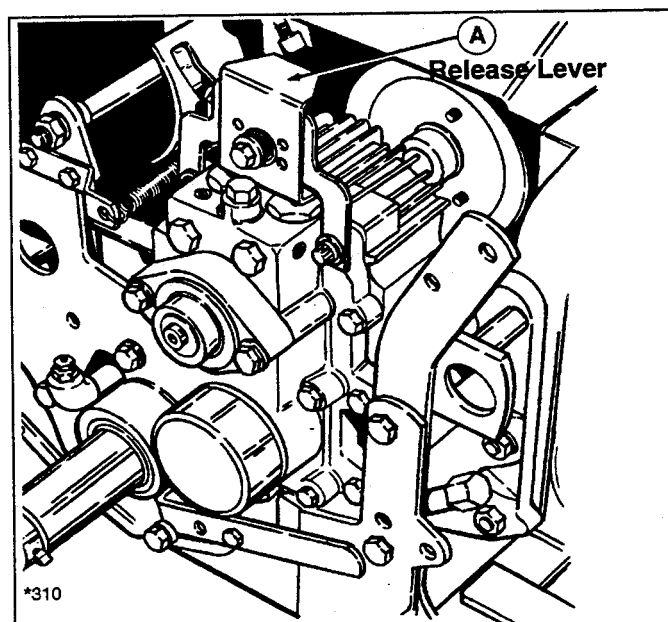

Figure 7. Transmission Release Lever

Mowing Patterns & Tips

For the first use of the mower, choose a smooth level area. Cut long straight strips overlapping slightly.

The size and type of area to be mowed determines the best mowing pattern to use. Obstructions such as trees, fences and buildings must also be considered. Where possible, make one or two passes in a counterclockwise direction around the outside of the area to keep the cut grass off fences and walks. The remainder of the mowing should be done in a clockwise direction so the clippings are dispersed on the cut area.

Keep in mind the following lawn care and mowing tips:

- Too much maintenance is as detrimental to your lawn as neglect.
- Mow when grass is 3-5 inches tall. Don't cut shorter than 2 to 2-1/2 inches. Cut only the top one-third of the grass blade. Cutting below this level can lead to thatch problems. Your mower has a cutting height adjustment that can help you maintain a proper length.
- For extremely tall grass, set the cutting height at maximum for the first pass, and then reset to the desired height and mow again.
- Mow often. Short clippings of an inch or less decompose more quickly than longer blades.
- Keep the blades on your mower sharp for finer clippings.
- Let grass grow a bit longer when it is hot to reduce heat build-up and protect grass from heat damage.
- Use slow-release fertilizer for slow, even growth.
- Don't cover grass surface with a heavy layer of clippings. Consider using a grass collection system and starting a compost pile.
- Aerate lawn in spring, consider renting an aerator which removes cores of soil from the lawn. This increases the speed of clipping decomposition and deep root growth by opening up the soil and permitting greater movement of water, fertilizer and air.
- Don't over-water. Too much water can encourage disease development.
- Mow when the grass is dry, preferably in the late afternoon when the temperatures are cooler.
- Where possible, change patterns occasionally to eliminate matting, graining or a corrugated appearance.
- For wet grasses, grasses prone to wheel tracking and for collecting clippings:
 - a. Use sharp blades.
 - b. Raise deck 1/4" higher in front than in rear.
 - c. Run at maximum engine speed but slow ground speed.
 - d. Clean deck of built-up material/caked-on grass.
 - e. Check for free movement of mower idler pulley.
- For dry conditions where grass blow-out is a problem:
 - a. Use sharp blades.
 - b. Raise deck so the front is even with, or 1/8" lower than, rear.
 - c. Use 3/4 engine speed.
 - d. Clean deck of built-up material/caked-on grass.

SCHEDULE

The following schedule should be followed for normal care of your tractor and mower. You will need to keep a record of your operating time.

| Safety Items | See Page | Every 5 Hours | Every 25 Hours | Every 100 Hours *Or Yearly |
|--|----------|---|----------------|-------------------------------|
| Check safety interlock system. | 7 | | | ● |
| Check tractor brakes. | 24 | | | ● |
| Normal Care Items | | | | |
| Check tractor & mower for loose hardware. | - | ● | | |
| Lubricate tractor and mower. | - | | ● | |
| Check tires. | 13 | | ● | |
| Oil Pivot points. | 15 | | ● | |
| Check transmission fluid. | 15 | ● | | |
| Change transmission fluid & filter. | 16 | Trans. service only or every 400 hours. | | |
| Check and clean battery. | 16 | | ● | |
| Clean, sharpen and balance blades. | 17 | | | ● |
| Clean and repack front wheel bearings. | - | | | ● |
| See engine manual for engine care & maintenance. | | | | |

* or as needed.

RAISING THE HOOD

To gain access to the engine compartment, release the rubber strap on each side of the hood and raise the hood.

CAUTION

Do not run the engine with the hood raised. Engine heat will cause damage to the headlight bezel and hood.

CHECKING/ADDING GASOLINE

Check the gas gauge/cap to be sure there is enough gasoline to complete the job. To add gasoline, remove the gas gauge/cap. Do not overfill. Leave room in the tank for fuel expansion. Refer to your engine manual for gasoline recommendations. Install and hand tighten the gas gauge/cap.

CAUTION

Never use gasoline containing METHANOL, gasoline containing more than 10% ethanol, gasoline additives, premium gasoline, or white gas because engine/fuel system damage could result.

CHECKING TIRE PRESSURE

Front tire pressure should be 12 to 15 psi (82 to 103 kPa). Rear tire pressure should be 6 to 8 psi (41 to 55 kPa).

CHECKING FUEL FILTER

WARNING

Do not remove fuel filter when engine is hot, as spilled gasoline may ignite. DO NOT spread hose clamps further than necessary. Ensure clamps grip hoses firmly over filter after installation.

The fuel filter is located in fuel line between fuel tank and carburetor. If filter is dirty or clogged, replace as follows. Place a container below filter to catch spilled gasoline.

- Using a pliers, open and slide hose clamps from fuel filter.
- Remove hoses from filter.
- Install new filter in proper flow direction in fuel line. Secure with hose clamps. See warning at beginning of procedure.

Normal Care

LUBRICATION

Tractor Lubrication

Lubricate the tractor as shown in figures 8 -10. When a grease gun is shown, wipe the fitting clean, apply two or three shots of lithium base automotive grease, and wipe off excess grease. When an oil can is shown, wipe the area clean, apply a few drops of oil (SAE 30), then wipe up drips or spills.

Mower Lubrication

1. Remove mower from tractor.
2. Remove cotter pins in order to lift the bail assembly.
3. See figure 11. Remove the taptite screws to remove the R.H. cover. Both covers can be removed to check/clean mower deck.
4. Apply a few drops of oil or one or two shots of grease (if equipped with grease fitting) to idler pulley pivot fitting and wipe off excess oil or grease. Do not get oil or grease on mower belt. Idler pulley pivot should be lubricated yearly.
5. Install cover and taptite screws. Be sure the belt fits inside of the belt guide which is located on bottom of cover.
6. Install bail assembly and secure with cotter pins. Be sure to spread cotter pins.
7. Lubricate the mower arbors as shown in figure 12.

CHECKING BEVEL GEAR BOX FLUID

1. Remove the fill plug (A, figure 13) and wipe oil off attached pin.
2. Insert the fill plug loosely in hole (do not screw it in). In this position, the fluid should just touch the bottom of the pin.
3. Add multi-purpose powertrain oil if required and install plug. Do not overfill.
4. To drain gear box, loosen the capscrews at the rear cover plate.

CHECKING TRANSMISSION FLUID

1. Park the tractor on a flat, level surface.
2. Wipe the transmission fill cap (C, figure 14) and fill tube (D) clean, then remove the cap.
3. Lift and hold the relief valve (E) open. Fluid should be at top of filler pipe. If not, add multi-purpose hydraulic transmission fluid oil. Relief valve must be held firmly up when adding oil.

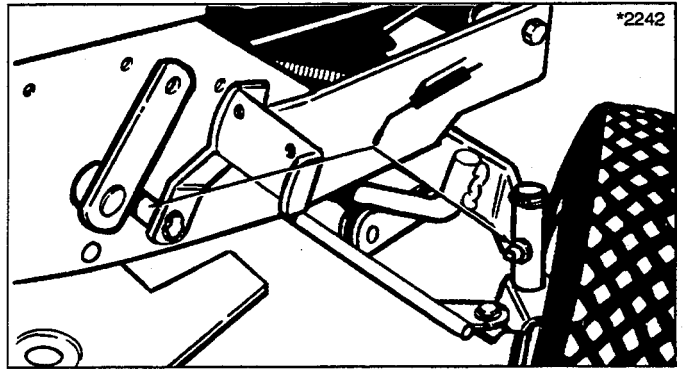

Figure 8. Clutch/Brake Pedal Grease Fitting

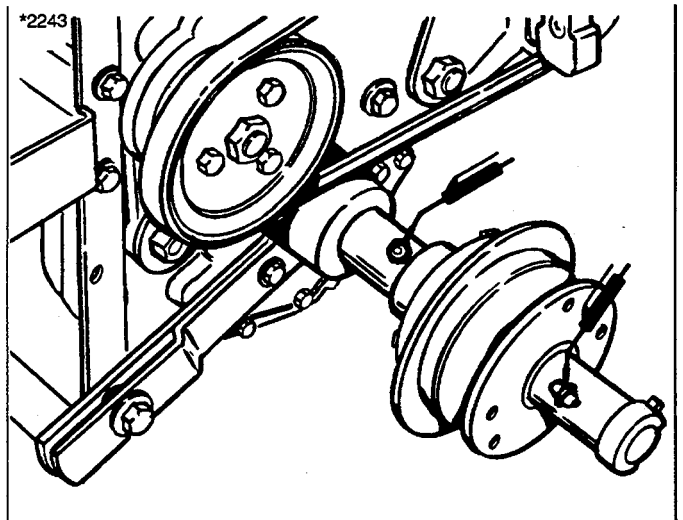

Figure 9. R.H. Rear Axle Grease Fittings (Two)

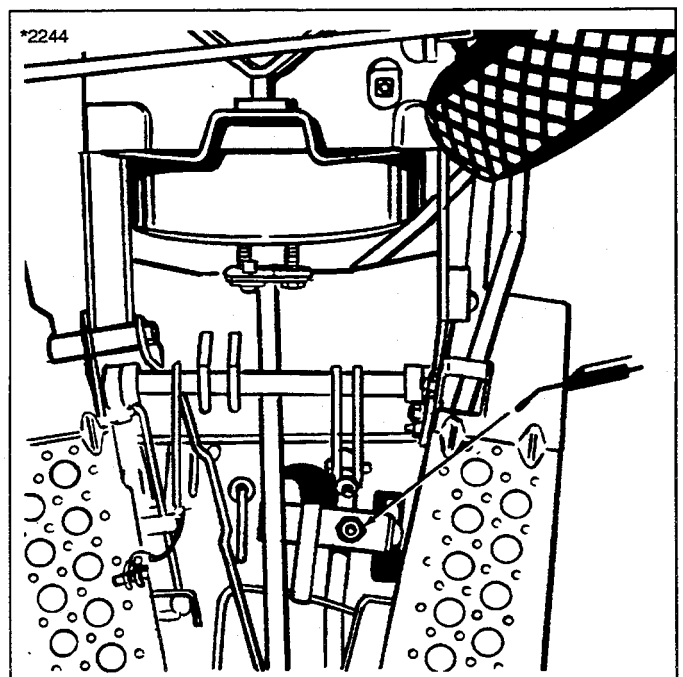

Figure 10. Steering Gear Grease Fitting

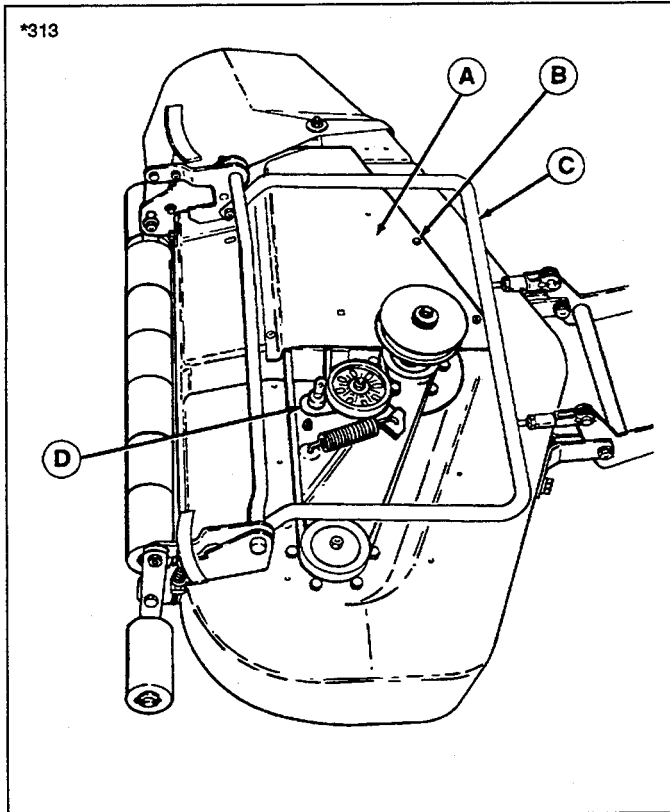

Figure 11. Idler Pulley Pivot
A. Cover **C. Bail Assembly**
B. Taptite Screws **D. Idler Pulley Pivot**

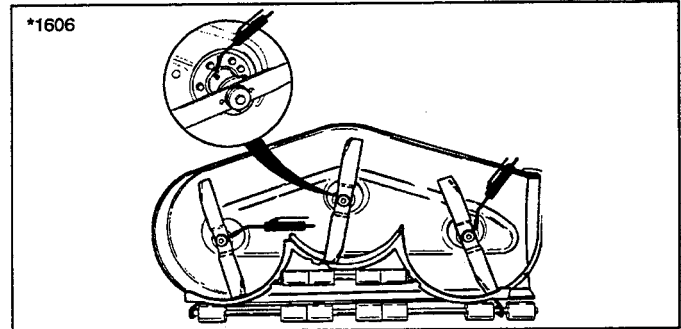

Figure 12. Mower Arbor

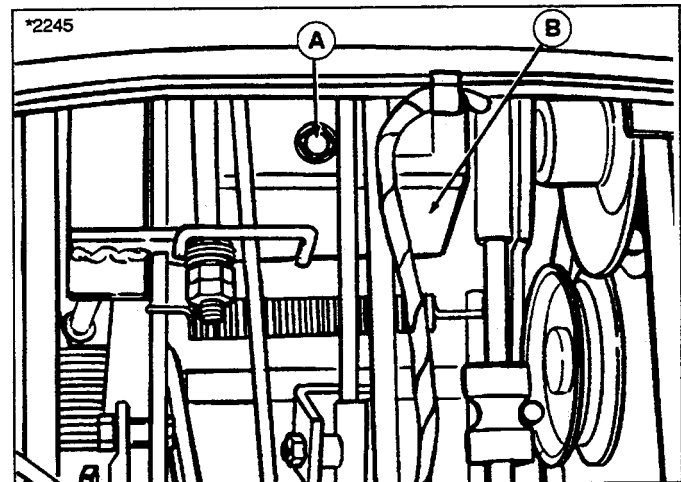

Figure 13. Bevel Gear Box
A. Oil Fill/Check Plug **B. Bevel Gear Box**

CHANGING TRANSMISSION FLUID & FILTER

NOTE: The filter is shown in figure 14. Replace the filter every 400 hours of operation or whenever changing transmission fluid. Transmission fluid should be changed only when performing repair work on transmission or hydrostatic unit, or if it becomes discolored from overheating.

1. With hydrostatic transmission fluid hot, park tractor on a hard, level surface. Place ground speed control lever in neutral, place PTO lever in disengaged position, engage the parking brake and then stop the engine.
2. Press transmission release lever (A, figure 14) down firmly to disengage the hydrostatic pump.
3. Remove hydrostatic transmission drain plug (B, figure 15) from lower right-hand side. Remove dirt from around the fill cap (C, figure 14) and loosen cap to permit air to enter transmission.
4. Clean dirt from the transmission filter and filter holder into which it is mounted. Remove and discard filter.

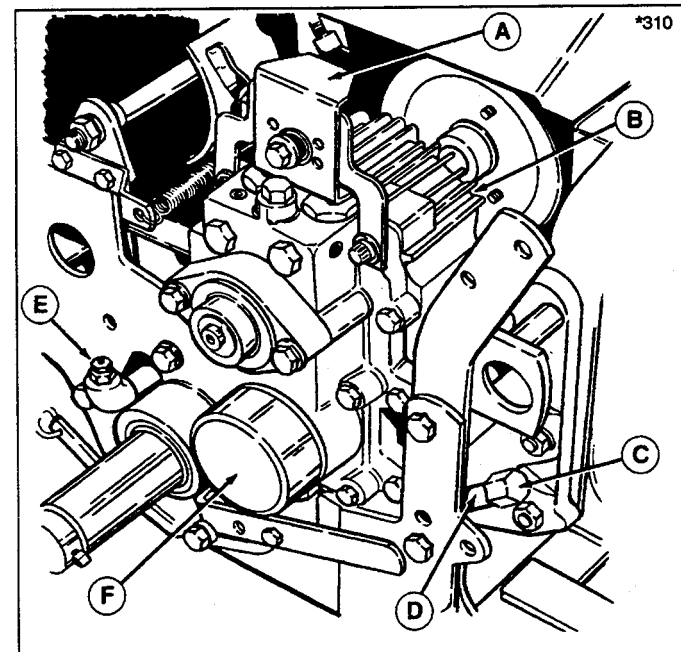

Figure 14. Hydrostatic Transmission
A. Release Lever **D. Fill Tube**
B. Cooling Fins **E. Relief Valve**
C. Fill Cap **F. Filter**

Normal Care

- When fluid has drained out of transmission, install new filter. Coat gasket on filter with transmission fluid. Screw filter on until it contacts base, then tighten 1/2 - 3/4 turn more. Do not use any tools to tighten filter. Turn by hand only.
- Install and tighten drain plug.
- Remove the fill cap (C, figure 14) and clean dirt away from relief valve (E). Using a clean funnel, add multi-purpose hydraulic transmission fluid into the fill tube while holding the relief valve up, until fill tube is full. Install fill tube and hand tighten.
- Start engine and set it at idle speed, or slightly above. Let engine run at least five minutes, then stop engine and immediately lift relief valve and remove fill tube cap. While relief valve is up, pour more fluid into the fill tube until level reaches the "run over" point of the tube.

WARNING

Make sure transmission release lever is firmly down and that parking brake is engaged before starting the engine.

- Install and tighten the fill tube cap. Be extremely careful to keep all dust and dirt out of transmission while changing oil and filter. Check filter and drain plug for leaks.

BATTERY MAINTENANCE

Checking the Battery Fluid

WARNING

Be careful when handling the battery. Avoid spilling electrolyte. Keep flames and sparks away from the battery.

- Raise the hood.
- Remove battery filler cap. Fluid must be even with split ring full mark. If not, add distilled water.
- Reinstall filler cap.

Cleaning the Battery and Cables

WARNING

When removing or installing battery cables, disconnect the negative cable FIRST and reconnect it LAST. If not done in this order, the positive terminal can be shorted to the frame by a tool.

- Disconnect the cables from the battery, negative cable first (B, figure 16).

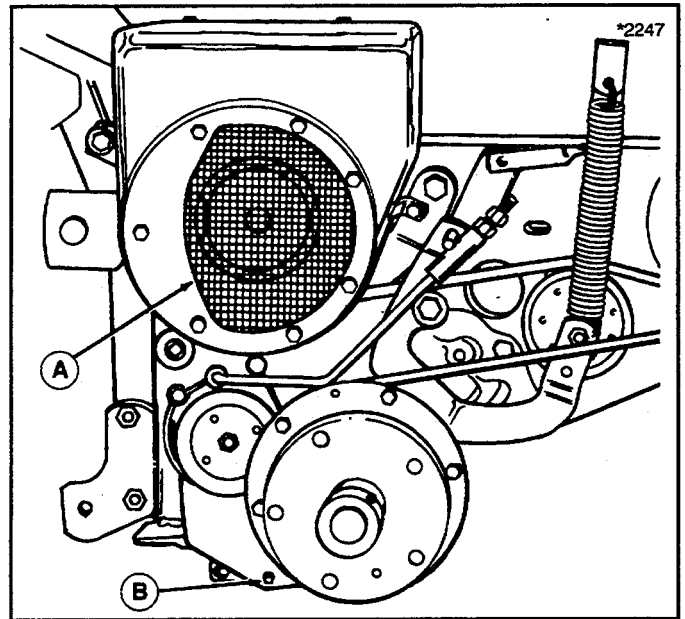

Figure 15. Hydrostatic Transmission
A. Cooling Fan Screen B. Drain Plug

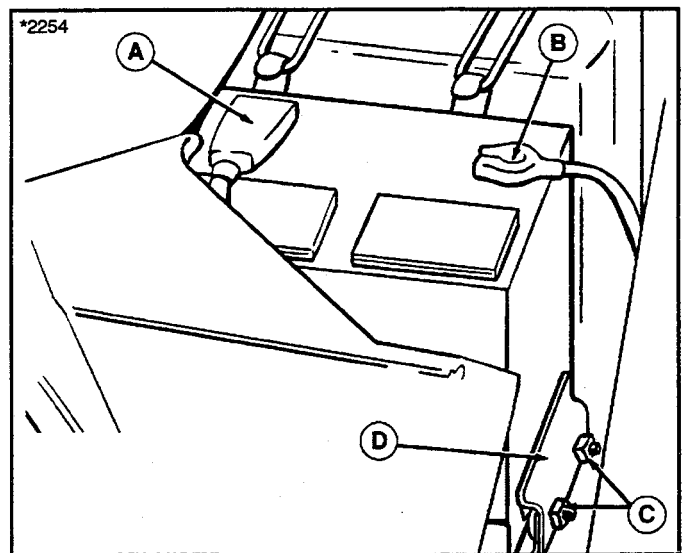

Figure 16. Battery Compartment
A. Positive Battery Terminal C. Locknuts
B. Negative Battery Terminal D. Battery Clamp

- Remove the battery clamp, then remove the battery.
- Scrub the battery, cables and battery compartment with baking soda and water.
- Clean the battery terminals and cable clamps with a wire brush and battery post terminal cleaner.
- Reinstall battery and clamp.
- Connect cables, positive cable first.
- Coat cable clamps and terminals with grease or petroleum jelly.

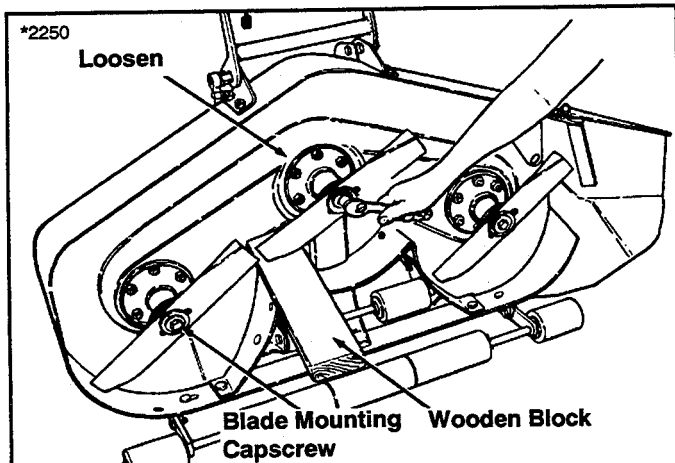

Figure 17. Removing The Blade

SERVICING THE MOWER BLADES

1. Remove mower from the tractor.
2. Blades should be sharp and free of nicks and dents. If not, sharpen blades as described in following steps.
3. To remove blade for sharpening, use wooden block to hold blade while removing the blade mounting cap screw (figure 17).
4. Use a file to sharpen blade to fine edge. Remove all nicks and dents in blade edge. If blade is severely damaged, it should be replaced.
5. Balance the blade as shown in figure 18. Center the blades' hole on a nail lubricated with a drop of oil. A balanced blade will remain level.
6. Reinstall each blade with the tabs pointing up toward deck as shown in figure 19. Secure with a cap screw (D), cup washer (C) and spline washer (B). Use a wooden block to prevent blade rotation and torque cap screws to 50-70 ft.lbs. (67-95 Nm.).

⚠ WARNING

For your personal safety, do not handle the sharp mower blades with bare hands. Careless or improper handling of blades may result in serious injury.

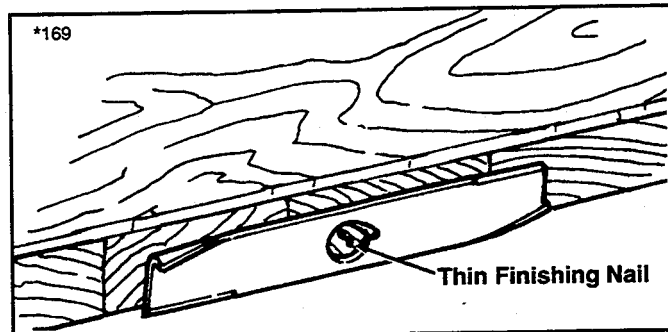

Figure 18 Balancing The Blade

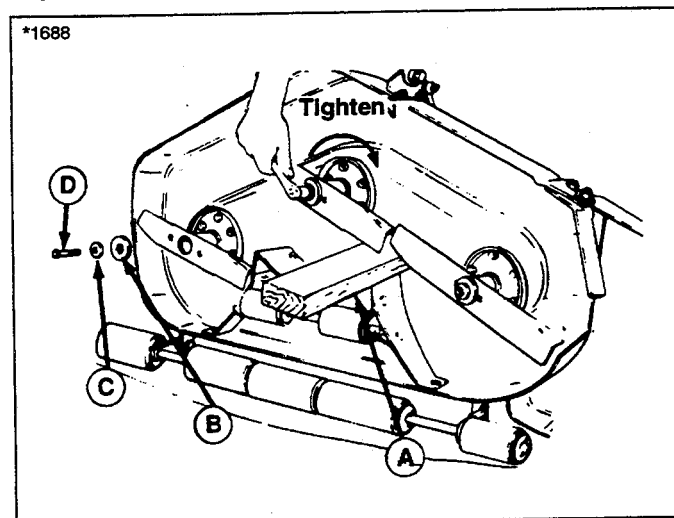

Figure 19. Installing The Blade

- | | |
|------------------|---------------|
| A. Wooden Block | C. Cup Washer |
| B. Spline Washer | D. Capscrew |

⚠ WARNING

For your personal safety, blade mounting cap screws must each be installed with a cup washer and spline washer, then securely tightened. Torque blade mounting cap screw to 50-70 ft.lbs. (67-95 N.m.)

Storage

WARNING

Never store the tractor, with gasoline in engine or fuel tank, in a heated shelter or in enclosed, poorly ventilated enclosures. Gasoline fumes may reach an open flame, spark or pilot light (such as a furnace, water heater, clothes dryer, etc.) and cause an explosion.

Handle gasoline carefully. It is highly flammable and careless use could result in serious fire damage to your person or property.

Drain fuel into an approved container outdoors away from open flame or sparks.

TEMPORARY STORAGE (30 Days Or Less)

Remember, the fuel tank will still contain some gasoline, so never store the tractor indoors or in any other area where fuel vapor could travel to any ignition source. Fuel vapor is also toxic if inhaled, so never store the tractor in any structure used for human or animal habitation.

Here is a checklist of things to do when storing your tractor temporarily or in between uses:

- Keep the tractor in an area away from where children may come into contact with it. If there's any chance of unauthorized use, remove the spark plug (s) and put in a safe place. Be sure the spark plug opening is protected from foreign objects with a suitable cover.
- If the tractor can't be stored on a reasonable level surface, chock the wheels.
- Clean all grass and dirt from the mower.

NOTE: If storing your tractor between winter snow removal jobs in a cold area, we suggest that you fill the fuel tank at the completion of each job to prevent water condensation in the fuel tank. Wait for engine to cool before filling tank.

LONG TERM STORAGE (Longer Than 30 Days)

Before you store your tractor for the off-season, read the Maintenance and Storage instructions in the Safety Rules section, then perform the following steps:

1. Drain crankcase oil while engine is hot and refill with a grade of oil that will be required when tractor is used again.
2. Prepare the mower deck for storage as follows:
 - a. Remove mower deck from the tractor.

- b. Clean underside of mower deck.
 - c. Coat all bare metal surfaces with paint or light coat of oil to prevent rusting.
3. Clean external surfaces and engine.
 4. Prepare engine for storage. See engine owner's manual.
 5. Clean any dirt or grass from cylinder head cooling fins, engine housing and air cleaner element.
 6. Cover air cleaner and exhaust outlet tightly with plastic or other waterproof material to keep out moisture, dirt and insects.
 7. Completely grease and oil tractor as outlined in the Normal Care section.
 8. Clean up tractor and apply paint or rust preventative to any areas where paint is chipped or damaged.
 9. Be sure the battery is filled to the proper level with water and is fully charged. Battery life will be increased if it is removed, put in a cool, dry place and fully charged about once a month. If battery is left in tractor, disconnect the negative cable.
 10. Drain fuel system completely or add a gasoline stabilizer to the fuel system. If you have chosen to use a fuel stabilizer and have not drained the fuel system, follow all safety instructions and storage precautions in this manual to prevent the possibility of fire from the ignition of gasoline fumes. Remember, gasoline fumes can travel to distant sources of ignition and ignite, causing risk of explosion and fire.

NOTE: Gasoline, if permitted to stand unused for extended periods (30 days or more), may develop gummy deposits which can adversely affect the engine carburetor and cause engine malfunction. To avoid this condition, add a gasoline stabilizer to the fuel tank or drain all fuel from the system before placing unit in storage.

11. Transport the tractor to a suitable, dry, indoor location. If the tractor is to be stored 6 months or longer, block the tractor up off the wheels to relieve weight and also to keep the tires off a damp floor. Protect tires from prolonged exposure to direct sunlight.

STARTING AFTER LONG TERM STORAGE

Before starting the tractor after it has been stored for a long period of time, perform the following steps.

1. Remove the blocks from under the tractor.

2. Install the battery if it was removed.
3. Unplug the exhaust outlet and air cleaner.
4. Fill the fuel tank with fresh gasoline. See engine manual for recommendations.
5. Check crankcase oil level and add proper oil if necessary.
6. Inflate tires to proper pressure. Check fluid levels.
7. Start the engine and let it run slowly. **DO NOT** run at high speed immediately after starting. Be sure to run engine only outdoors or in well ventilated area.

Troubleshooting & Repair

GENERAL

WARNING

To avoid serious injury, perform maintenance on the tractor or mower only when the engine is stopped and the parking brake engaged. Always remove the ignition key, disconnect spark plug wire and fasten away from the plug before beginning the maintenance, to prevent accidental starting of the engine.

This section of the manual provides troubleshooting and repair instructions for the more common and easily corrected problems. For other problems, it is recommended that you contact your dealer. Locate the problem that best describes the trouble that you have encountered. Check the possible causes one at a time, in the order that they are listed.

TROUBLESHOOTING THE TRACTOR

Engine will not turnover or start.

1. Ground speed control lever not in neutral-start position. Shift into neutral.
2. PTO lever in ON position. Place in OFF position.
3. Out of fuel. If engine is hot, allow it to cool, then refill the fuel tank.
4. Engine flooded. Push choke knob in.
5. Circuit breaker tripped. Wait one minute for automatic reset. Replace if defective (see your dealer).
6. Battery terminals require cleaning. See Normal Care section.
7. Battery discharged or dead. Recharge or replace.
8. Wiring loose or broken. Visually check wiring & replace broken or frayed wires. Tighten loose connections.
9. Solenoid or starter motor faulty. Repair or replace.
10. Safety interlock switch or module faulty. Replace if needed (see your dealer.)
11. Operator not in seat.

Engine cranks but will not start.

1. Out of gasoline.
2. Engine flooded. Push in choke and attempt to start. Hold throttle wide open.
3. Crankcase oil too heavy. See engine manual.
4. Water in gasoline or gasoline is stale. Drain and fill with fresh gasoline.
5. Faulty engine electrical or fuel system. See engine manual or your dealer.

Engine starts hard or runs poorly.

1. Fuel mixture too rich. Clean air filter. Check choke adjustment (engine speed control). See engine manual.
2. Carburetor adjusted incorrectly. See engine manual.
3. Spark plug(s) faulty, fouled, or incorrectly gapped. Clean and gap or replace. See engine manual.
4. In hot weather, fuel may evaporate from carburetor when engine is shut off, causing engine to run rough for a few minutes after starting. Do not shut off; allow engine to clear itself.
5. Start engine with throttle midway between slow and fast.

Engine knocks.

1. Low oil level. Check/add oil as required.
2. Using wrong grade oil. See engine manual.
3. Wrong grade of gasoline. Use fresh, regular grade of gasoline.

Excessive oil consumption.

1. Engine running too hot. Clean engine fins, blower screen and air cleaner.
2. Using wrong weight oil. See engine manual.
3. Too much oil in crankcase. Drain excessive oil.

Engine exhaust is black.

1. Dirty air filter. Clean air filter. See engine manual.
2. Check engine speed control adjustment (choke). See engine manual.
3. Carburetor adjustment is incorrect. See engine manual or your dealer.

Tractor creeps in neutral.

1. Tractor creeps forward or backward with ground speed control lever in neutral gate. Perform Neutral Adjustment.

Engine runs, but tractor will not drive or lacks power.

1. Ground speed control lever in neutral. Shift in forward or reverse.
2. Transmission oil cold. Allow 3 minutes for warm-up.
4. Transmission fluid low. Add as required. Check for leaks.
5. Transmission oil too hot. Check transmission cooling fins for grass or clippings and clean with brush or compressed air. Do not use water.

6. Belt is broken. See Drive Belt Replacement.
7. Brake is not fully released. See Brake Adjustment.

Brake will not hold.

1. Brake is incorrectly adjusted. See Brake Adjustment.
2. Brake lining worn. Replace.

Engine backfires when shut off.

1. Engine backfire may occur when shut off hot. To reduce backfiring, move throttle lever midway between fast and slow for a couple seconds before shut off.
2. Carburetor solenoid not functioning. See your dealer.

TROUBLESHOOTING THE MOWER

Mower will not raise.

1. Lift mechanism not attached or broken. Attach or replace as necessary.
2. Hydraulic lift system faulty. See your dealer.

Mower cut is uneven.

1. Mower not leveled properly. See Mower Adjustment.
2. Tractor tires not inflated equally or properly. See Normal Care.
3. Missing pin on mower hitch. Install pin.

Mower cut is rough looking.

1. Engine speed too slow. Set for full throttle speed.
2. Ground speed too fast. Set ground speed control lever at a slower ground speed.
3. Blades dull and require sharpening. See Servicing the Mower Blades.
4. Mower arbor belt slipping. Belt oily or worn. Clean or replace belt as necessary.
5. Mower idler pulley pivot sticking. Check/lubricate as necessary. See Normal Care.
5. Check PTO Adjustment. Clutch may need to be adjusted.
6. Blades not properly fastened to arbors or bent. See Servicing the Mower Blades.

Engine stalls easily with mower engaged.

1. Engine speed too slow. Set for 3/4 to full throttle.
2. Ground speed too fast.
3. Engine cold. Allow warm-up period.
4. Cutting height set too low when mowing tall grass.

Cut tall grass at maximum cutting height during first pass.

5. Discharge chute jamming with cut grass. Cut grass with discharge pointing toward previously cut area.

Excessive mower vibration.

1. Blade mounting screws are loose. Tighten to 50-70 ft.lbs. (74 Nm.).
2. Mower blades, arbors, or pulleys are bent. Check and replace as necessary.
3. Mower blades are out of balance. Remove, sharpen and balance blades. See Servicing the Mower Blades.

Excessive belt breakage.

1. Incorrect belt. Use belt designed for your mower.
2. Bent, loose or rough pulleys. Repair or replace.
3. Damaged mower pulley. See your dealer.

Mower drive belt slips or fails to drive.

1. Pulleys or belt greasy or oily. Clean.
2. Belt stretched. Replace belt.
3. Mower idler pulley pivot sticking. Check/lubricate as necessary.

CHECKING THE BATTERY

A dead battery or one too weak to start the engine may not mean the battery needs to be replaced. It may, as an example, mean that the alternator is not charging the battery properly. If there is any doubt about the cause of the problem, see your dealer. If you need to replace the battery, follow the steps under Cleaning the Battery & Cables in the Normal Care Section.

CHARGING A COMPLETELY DISCHARGED BATTERY

⚠ WARNING

Do not attempt to charge a frozen battery. Allow the battery to warm to 60° F (15.5° C) before placing on charge.

1. Be aware of all the safety precautions you should observe during the charging operation. If you are unfamiliar with the use of a battery charger and hydrometer, have the battery serviced by your dealer.
2. Add water sufficient to cover the plate (fill to the proper level near the end of the charge). If the battery is extremely cold, allow it to warm before adding water

Troubleshooting & Repair

because the water level will rise as it warms. Also, an extremely cold battery will not accept a normal charge until it becomes warm.

3. Always unplug or turn the charger off before attaching or removing the clamp connections.
4. Carefully attach the clamps to the battery in proper polarity (usually red to [+] positive and black to [-] negative).
5. While charging, periodically measure the temperature of the electrolyte. If the temperature exceeds 125° F (51.6° C), or if violent gassing or spewing of electrolyte occurs, the charging rate must be reduced or temporarily halted to prevent battery damage.

WARNING

Keep open flames and sparks away from the battery; the gasses coming from it are highly explosive. Ventilate the battery well during charging.

6. Charge the battery until fully charged (i.e. until the specific gravity of the electrolyte is 1.250 or higher and the electrolyte temperature is at least 60° F). The best method of making certain a battery is fully charged, but not over charged, is to measure the specific gravity of a cell once per hour. The battery is fully charged when the cells are gassing freely at low charging rate and less than 0.003 change in specific gravity occurs over a three hour period.

JUMP STARTING WITH AUXILIARY (BOOSTER) BATTERY

WARNING

For your personal safety, use extreme care when jump starting. Never expose battery to open flame or electric spark – battery action generates hydrogen gas which is flammable and explosive. Do not allow battery acid to contact skin, eyes, fabrics, or painted surfaces. Batteries contain a sulfuric acid solution which can cause serious personal injury or property damage.

CAUTION

To avoid engine damage, do not disconnect battery while engine is running. Be sure terminal connections are tight before starting.

Jump starting is not recommended. However, if it must be done, follow these directions. Both booster and discharged batteries should be treated carefully when using jumper cables. Follow the steps below EXACTLY, being careful not to cause sparks. Refer to figure 20.

1. Both batteries must be of the same voltage (6, 12, etc.).
2. Position the vehicle with the booster battery adjacent to the vehicle with the discharged battery so that booster cables can be connected easily to the batteries in both vehicles. Make certain vehicles do not touch each other.
3. Wear safety glasses and shield eyes and face from batteries at all times. Be sure vent caps are tight. Place damp cloth over vent caps on both batteries.
4. Connect positive (+) cable to positive post of discharged battery (wired to starter or solenoid).
5. Connect the other end of same cable to same post marked positive (+) on booster battery.
6. Connect the second cable negative (-) to other post of booster battery.
7. Make final connection on engine block of stalled vehicle away from battery. Do not lean over batteries.
8. Start the engine of the vehicle with the booster battery. Wait a few minutes, then attempt to start the engine of the vehicle with the discharged battery.
9. If the vehicle does not start after cranking for thirty seconds, STOP PROCEDURE. More than thirty seconds seldom starts the engine unless some mechanical adjustment is made.
10. After starting, allow the engine to return to idle speed. Remove the cable connection at the engine or frame. Then remove the other end of the same cable from the booster battery.

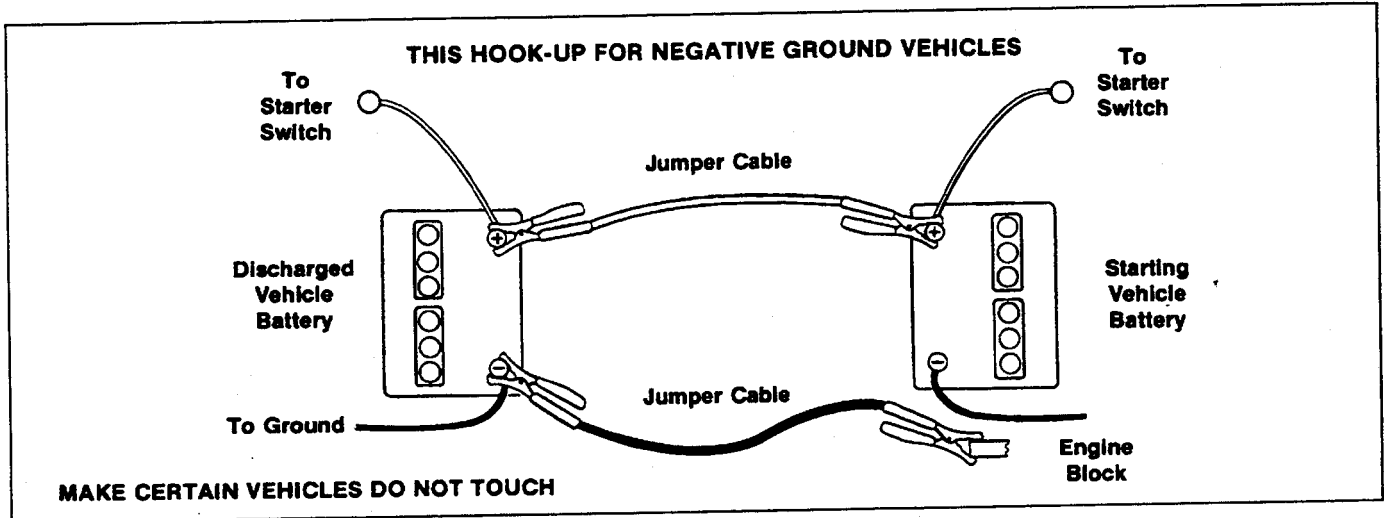

Figure 20. Jump Starting Diagram

⚠ WARNING

Any procedure other than the preceding could result in: (1) personal injury caused by electrolyte squirting out the battery vents, (2) personal injury or property damage due to battery explosion, (3) damage to the charging system of the booster vehicle or of the immobilized vehicle.

Do not attempt to jump start a vehicle having a frozen battery because the battery may rupture or explode. If a frozen battery is suspected, examine all fill vents on the battery. If ice can be seen or if the electrolyte fluid cannot be seen, do not attempt to start with jumper cables as long as the battery remains frozen.

HEADLIGHT BULB REPLACEMENT

1. Disconnect the two wires from back of headlight. Note position to reconnect to same terminals.
2. Turn socket to left to disconnect and pull out.
3. Replace the bulb.
4. Align the two tabs and insert socket. Turn to the right to lock. Terminals will be at 12 o'clock and 6 o'clock positions.

Adjustments

⚠ WARNING

To avoid serious injury, perform adjustments only with engine stopped, key removed and tractor on level ground.

SEAT ADJUSTMENT

SEAT-SLIDE EQUIPPED MODELS

For units equipped with a Seat Slide, See Figure 21. Use the lever under the front of the seat to adjust the seat forward or rearward for best rider comfort.

STANDARD MODELS

1. See Figure 22. Lift up the seat and loosen the four capscrews.
2. Slide the seat forward or back and tighten the capscrews.

PTO ADJUSTMENT

See Figure 23.

The PTO clutch is properly adjusted when the clutch pulley (C) moves away from clutch cone (D) $1/16''$ (1.5 mm) when clutch is disengaged. To adjust, proceed as follows:

1. Loosen the rear nut (B).
2. Turn the front nut slightly clockwise to increase pulley travel or counterclockwise to decrease pulley travel.
3. Tighten the rear nut against the front nut and check the measurement again.
4. Adjust locknut (E) so there is $1/8''$ (3 mm) between locknut (E) and pivot arm when clutch is disengaged.

PARKING BRAKE ADJUSTMENT

See Figure 24.

1. Loosen jam nut (E) at parking brake rod end. Rotate the parking brake handle (B) clockwise until it is tight and pulled up against fender as shown.
2. Operate the brake handle to see if it is too loose or too tight. It should be tight against fender when set but not too tight to operate.
3. When proper adjustment is achieved, tighten jam nut.

NOTE: It will be easier to apply the parking brake when the clutch/brake pedal is fully engaged.

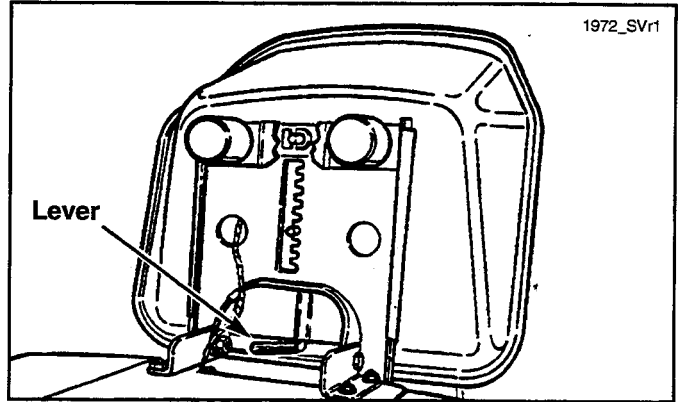

Figure 21 Seat Adjustment

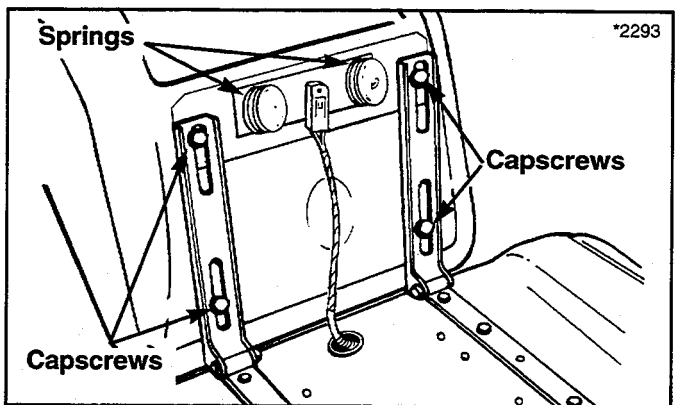

Figure 22 Seat Adjustment

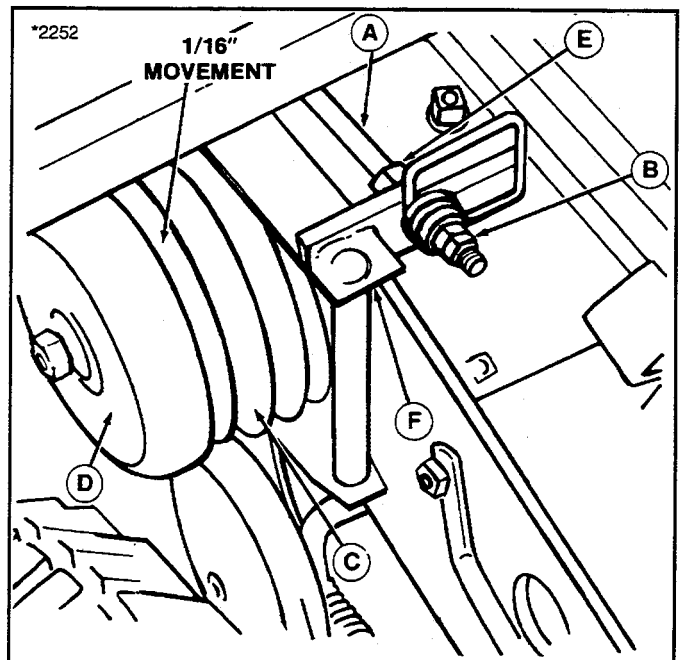

Figure 23. PTO Clutch Adjustment

- | | |
|-------------------|----------------|
| A. PTO Clutch Rod | D. Clutch Cone |
| B. Jam Nuts | E. Locknut |
| C. Clutch Pulley | F. Pivot Arm |

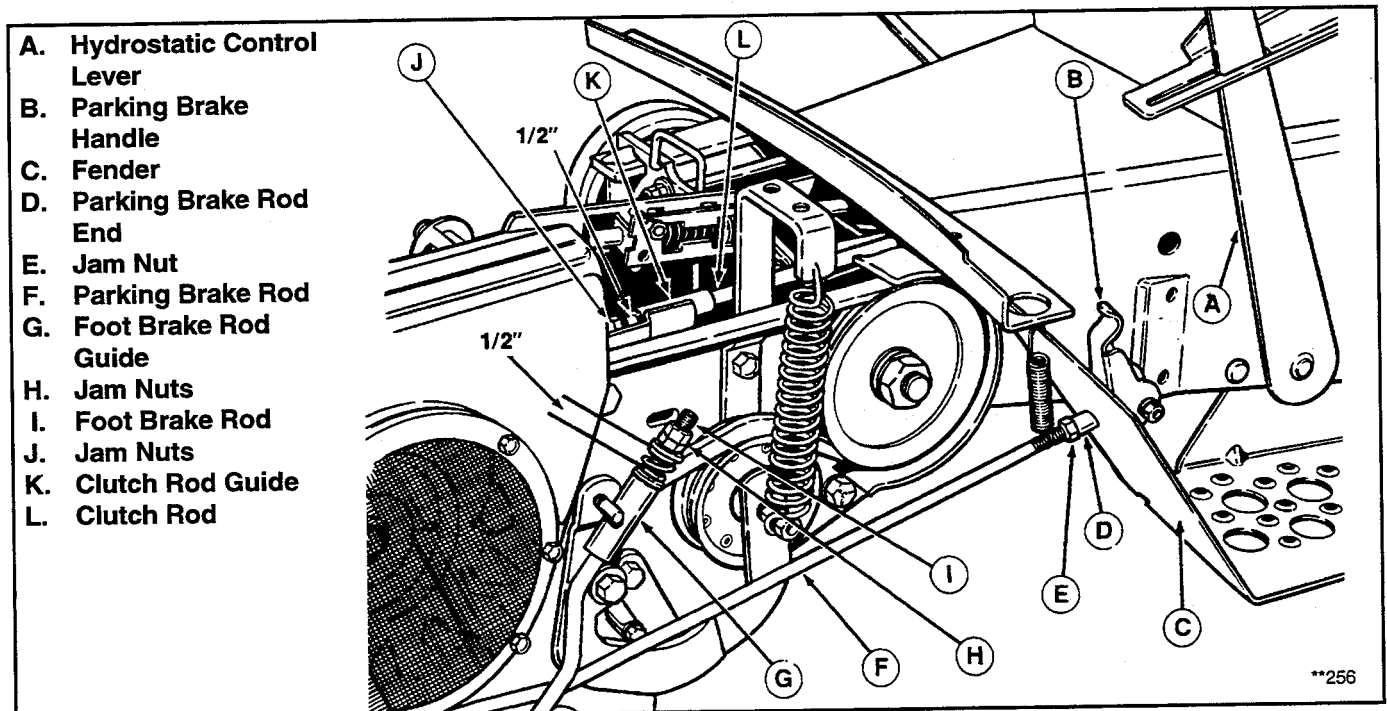

Figure 24. Clutch/Brake Adjustment

CLUTCH/BRAKE ADJUSTMENT

See Figure 24.

1. Engage the parking parking brake. Adjust jam nuts (H) on end of foot brake rod to provide 1/2" (12.7 mm) spring length between washers.
2. Depress the pedal to engage the brake. The drive belt should be slack and free of idler pulley. If not, perform step 3. Test operate the tractor. If brake does not stop the tractor, see your dealer.
3. To adjust tractor clutch, adjust jam nuts (J) on clutch rod so there is 1/2" (12.7 mm) spring length between washers with clutch/brake pedal in up position.

NEUTRAL ADJUSTMENT

See Figure 25.

If tractor creeps forward or back when ground speed control lever is in neutral, adjust as follows:

1. Park tractor on level ground. Make sure ground speed control lever is firmly seated in the neutral gate. Stop engine and set parking brake. 2. Raise the seat deck and check if the pump control arm roller (E) is exactly centered with the centering mark (D). If not, loosen bolt (C) and move the control cam (B) until centering mark (D) is centered on roller (E). Tighten the bolt (C).
3. Lower the seat deck, get in operator's seat, start engine and release parking brake. If tractor still

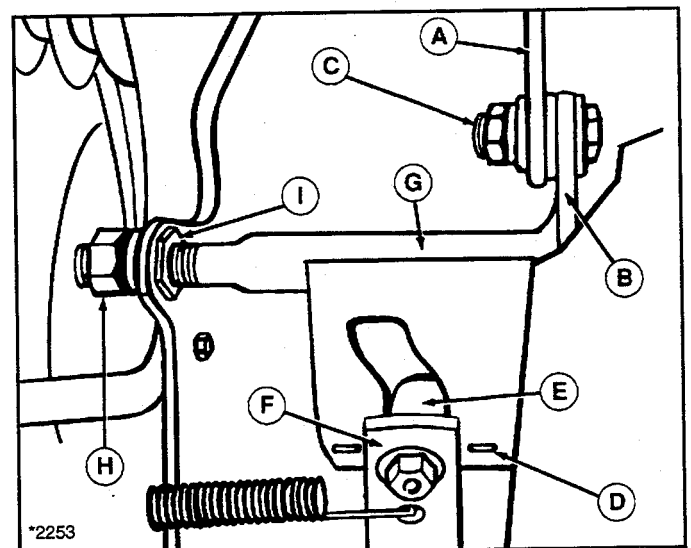

Figure 25. Neutral Adjustment

- | | |
|----------------------------|---------------------|
| A. Control Strap | F. Pump Control Arm |
| B. Control Cam Assy. | G. Cam Pivot Shaft |
| C. Bolt | H. Jam Nut |
| D. Centering Mark | I. Adjusting Nut |
| E. Pump Control Arm Roller | |

Adjustments

creeps with the ground speed control lever in neutral,

⚠ WARNING

Before checking mower, shut off PTO and engine. Allow all moving parts to stop. Remove ignition key, then disconnect the spark plug wire and fasten it away from the spark plug.

proceed to step 4.

4. Stop the engine, set the parking brake and raise the seat deck. Loosen the jam nut (H) on end of cam pivot shaft (G). If tractor creep had been in reverse, turn adjusting nut (I) 1/8 - 1/4 turn clockwise when viewed from right side of tractor.

If tractor was creeping forward, turn nut 1/8 - 1/4 turn counterclockwise and lock jam nut

5. Lower seat deck and get in operator's seat. Start engine and release parking brake. If tractor still creeps, repeat step 4, turning adjusting (I) until creeping stops.

LEVELING THE MOWER

If the cut is uneven, the mower may need leveling. Unequal or improper tire pressure may also cause an uneven cut. Make sure tire pressure is correct as specified in Checking Tire Pressure.

See Figure 26.

1. Turn both height adjustment handles (A) fully clockwise to the highest cutting height position.
2. Rotate the mower blades so the tips point straight forward and backward.
3. Measure and note the distance from the front tip of the center blade to the ground.
4. Measure the distances from the rear tips of the two outside blades to the ground. They should be the same. The rear measurement of the outside blades should be 1/8" - 1/4" (3 - 6 mm) less than the measurement for the front tip of the center blade. IF the measurements are not correct, proceed to step 5.
5. Loosen the jam nuts (B). Remove the cotter pins and then disconnect the eyebolts or yokes (C) from the mower hitch.
6. Turning the eyebolts to change the length of the bail assembly arms. Shorten the arms to decrease the front height of the mower; lengthen the arms to increase the front height of the mower. Be sure to turn both yokes an equal number of turns for front-to-back leveling.

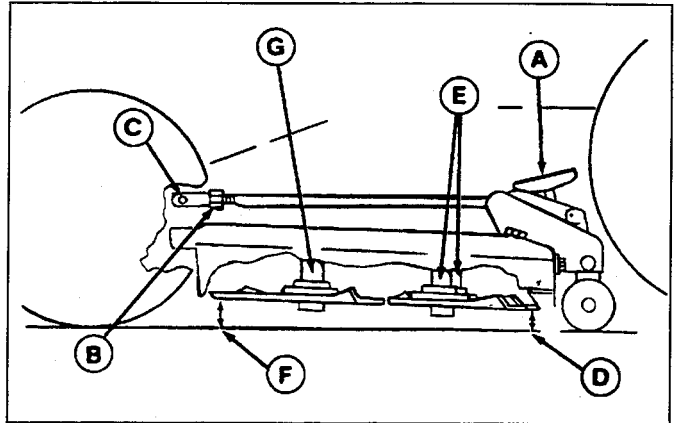

Figure 26. Mower Leveling

- A. Height Adjustment Handle**
- B. Jam Nut**
- C. Yoke**
- D. Height of Side Blades**
- E. Side Blades**
- F. Height of Center Blade**
- G. Front Blade**

7. Reinstall the yokes on the hitch. It is not necessary to install the cotter pins yet. Check the blade tip measurements as described in steps 3 & 4. Continue adjusting the yokes until the front tip of the center blade is 1/8" - 1/4" (3 - 6 mm) higher than the rear tips of the side blades.
8. Reinstall the cotter pins securing the yokes to the hitch. Spread the cotter pin legs, then tighten the jam nuts (B).

BLADE BRAKE ADJUSTMENT

Mower blades and mower drive belt should come to a complete stop within five seconds after front PTO is turned off.

1. With tractor in neutral, PTO disengaged and operator in seat, start the tractor engine.
2. Look over the left-hand footrest at the mower drive belt. Engage the PTO and wait several seconds. Disengage the PTO and check the amount of time it takes for the mower drive belt to stop.
3. If mower drive belt does not stop within five seconds, perform the steps described under PTO Clutch Adjustment. Repeat steps 1 and 2. If belt still does not stop within 5 seconds, see your dealer.

CAUTION

To avoid damaging belts, do not pry belts over pulleys.

TRACTOR DRIVE BELT

See Figure 27.

1. Park the tractor on a smooth, level surface such as a concrete floor. Disengage the PTO, turn off the engine and lock the parking brake. Remove the key.
2. Tie the clutch/brake pedal down in the disengaged position.
3. Raise the tractor seat deck. Remove the capscrew (C) and belt guard assembly (B).
4. Remove the two capscrews (D) and the taptite screw (E) in order to remove the fan guard assembly.
5. Remove the old belt and install the new one. Make sure the belt is in all pulley grooves and is not twisted.
6. Reinstall the fan guard with the capscrews (D) and the taptite screw (E).
7. Release the clutch/brake pedal and check to be sure belt is still seated in all pulleys.
8. Reinstall the belt guard (B) so the bracket on the back side almost touches the pulley hub. Hold the guard in place and tighten the capscrew (B).
9. Check and adjust the tractor clutch according to the instructions in the Adjustment section.
10. Lower and latch the seat deck when finished.

MOWER BELT

See Figure 28.

1. Set the parking brake, disengage the PTO, turn off engine and remove the key.
2. Remove mower from the tractor.
3. Lift the bail assembly (D) slightly to provide access for cover removal. Then lift the inner edge of the right-hand cover up over the lift anchor (F) and slide it out.
4. Clean the interior of the mower housing.
5. The idler pulley arm pivots at the lift anchor. Make sure the arm pivots freely. Lubricate the idler pivot fitting as necessary with a drop of oil. Do not get oil on the mower belt.

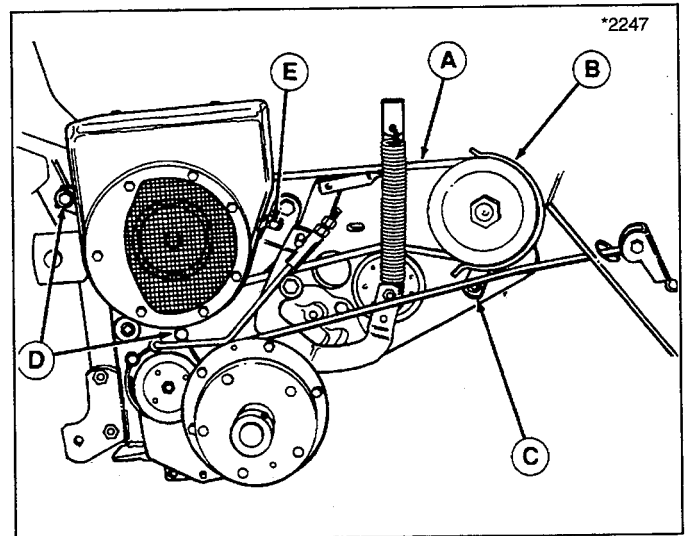

Figure 27. Drive Belt Replacement

- | | |
|---------------|---------------------|
| A. Belt | D. Fan Guard Screws |
| B. Belt Guard | E. Taptite Screw |
| C. Capscrew | |

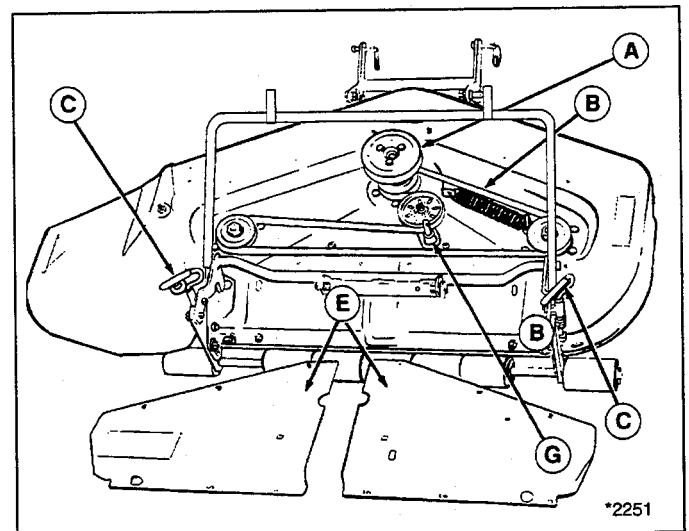

Figure 28. Mower Belt

- | | |
|------------------------------|-----------------------------------|
| A. Idler Pulley | D. Bail Assembly |
| B. Mower Belt | E. Belt Covers (Shown Removed) |
| C. Height Adjusting Lever | F. Lift Anchor |
6. Unhook the idler spring (B) from the idler (A). Remove the old belt from the pulleys. Install the new belt and attach the idler spring (B).
 7. Install the belt covers and connect the bail assembly. When installing the right-hand belt cover, be sure the belt is positioned in the belt guide which is located on the bottom of the belt cover.

Specifications

NOTE: Specifications are correct at time of printing and are subject to change without notice.

ENGINE

18 HP Kohler

| | |
|--------------------------|--|
| Model | Command OHV |
| Horsepower | 18 HP @ 3600 rpm |
| Cylinders | 2 |
| Bore | 3.03 In. (77 mm) |
| Stroke | 2.64 In. (67 mm) |
| Displacement | 38 Cu. In. (624 cc) |
| Construction | Cast Iron Sleeves, Aluminum Crankcase |
| Electrical System | 12 Volt, 15 Amp Alternator Regulated Battery: 296 Cold Cranking Amps, 60 min. Reserve Capacity, Industrial Rated Starter Motor |
| Ignition | Electronic Ignition |
| Governor | Internal Flyweight with external Adjustment |
| Air Cleaner | Dual Element |
| Lubrication | Full Pressure Lube with Oil Filter |
| Oil Capacity | 2 Quarts (1.9 L) |
| Fuel Tank | Material: Non-Corrosive Polyethylene Fuel Tank, Capacity: 3 Gallons (11.4 L) |
| Muffler | Quiet Compact, Low Back Pressure |

TRANSMISSION

| | |
|------------------------|---|
| Type | Hydrostatic Pump & Motor Air Cooled W/Fan |
| Pump | Variable Displacement Axial Type |
| Motor | Fixed Displacement Reversible Axial Type |
| Hydraulic Fluid | Simplicity Multi-Purpose Hydro Transmission Oil Reservoir: 3 Qt. Capacity (2.8 L) Filter: Cartridge w/25 Micron Rating Full Flow w/o Anti-Drain Back |
| Control | Spring Dampened Single Lever Free Wheeling Valve for Manual Tractor Movement |
| Speeds | Forward: 0 - 7 MPH (0 - 11.3 km/h) |
| @3400 RPM | Reverse: 0 - 4 MPH (0 - 6.4 km/h) |
| Differential | Planetary Spur Gear, Controlled Traction Type |
| Final Drive | Hardened Spur Gears Rolling Contact Bearings |

CONTROLS

| | |
|---------------------|---|
| Steering | Full Circle Steering Wheel 4.14 to 1 Ratio, Gear and Sector |
| Clutch/Brake | Location Right Front; Clutch is soft action, V-belt Clutch, Brake is external band type |
| Location | Implement Lift Lever: Left side (Hydraulic) PTO Clutch Lever: Left side Ground Speed Control Lever: Right Side Ignition Key: On Dash Light Switch: On Dash Throttle Control: On Dash, Left Side Choke Control: On Dash Ammeter: On Dash Parking Brake: Lower Right Side of Seat |

CHASSIS

| | |
|---------------------------|---|
| Frame | Channel Electrically Welded Heavy Gauge Steel Power Take-Off Points: Front, Center & Rear Engine Mounting Above Front Axle Pivot Point Location: double Pivoting Heavy Duty Cast Front Axle |
| Rear Wheels | Tire Size 23 x 10.5-12 Pneumatic Inflation Pressure 6-8 psi (41-55 kPa) |
| Front Wheels | Tire Size 16 x 6.50-8 Pneumatic Inflation Pressure 12-15 psi (82-103 kPa) |
| Accessibility Seat | Hood Tips Forward Type Bucket, High Back, Adjustable w/ Spring Suspension |
| Turning Radius | Inside Rear Tire 32 In. (81 cm) |

DIMENSIONS

| | |
|-----------------------------------|--|
| Overall Length | 70 In. (178 cm) |
| Overall Width | 36.9 In. (94 cm) |
| Height | To Top of Steering Wheel 39.7 In. (101 cm) |
| Wheel Base | 50.7 In. (127 cm) |
| Weight (approx.) w/o mower | 689 lbs. |
| w/mower | 956 lbs. |

COMMON REPLACEMENT PARTS

Listed below are the more common replacement parts. Only genuine factory replacement parts will assure optimum performance and safety. Do not attempt repairs or maintenance unless proper procedures and safety precautions are followed. For assistance in any area, see your dealer.

| QTY. | DESCRIPTION | PART NO. |
|------|--------------------------|----------|
| 3 | Mower Blade (48" Mower) | 1679916 |
| 1 | Mower Belt (48" Mower) | 1657044 |
| 1 | Tractor PTO Belt | 1713515 |
| 1 | Oil Filter - Hydro Pump | 1709322 |
| 1 | Ignition Key Set | 1714054 |
| 1 | Battery | 1685058 |
| 2 | Mower Hitch Pins | 156306 |
| 2 | Clips for Mower Pins | 176012 |
| 2 | Headlamp Bulb | 1677371 |
| 1 | Clevis Pin - Lift Cable | 153058 |
| 1 | Cotter Pin - Lift Cable | 1918447 |
| 1 | Spring Clip - Lift Cable | 1918196 |

**USE ONLY GENUINE
FACTORY REPLACEMENT PARTS**
Available Through Your Local
Authorized Dealer

MAINTENANCE ITEMS

- **Simplicity Engine Oils**
Case of 12 qts. (Your dealer has 1 qt. cans)
-SAE 5W-30 SF/CD (Cold Weather 30° & under) 1685576
-SAE 30W 3G/CC (Warm weather 32° & up) 1685659
- **Simplicity Hydro Transmission Oil**
Case of 12 qts. (Your dealer has 1 qt. cans) 1685516
- **Touch-Up Paint**
Deep Orange Spray Paint, 13 oz. Can 1685611
Deep Orange Paint, 1 qt. 1685612
Black Spray Paint, 13 oz. Can 1685639
Red Spray Paint, 13 oz. Can 1685722
Metallic Gray, 13 oz. Can (Wheels) 1685718
- **Touch-Up Daubers**
Deep Orange 1/2 oz. w/Brush Cap 1685615
- **Grease Gun Kit w/8 oz. Grease Tube** 1685510
Replacement 8 oz. Grease Tube for above 103077
- **Tire Sealant-Stops Tire Leaks. Prevents Flats.**
11 oz. Tube 1685523
- **Gas Can-No Tip Design. Durable Polyethylene.**
1 gallon 1685587
2-1/2 gallon 1685555
5-1/4 gallon 1685556
- **Cleaner, Polish, Sealant & Protectant** 1685696
8 oz. Bottle
- **Degreaser/Degreaser**
32 oz. Bottle w/Trigger Spray 1685619
1 gallon 1685621

Parts & Accessories

OPTIONAL ACCESSORIES

See your dealer to purchase these items.

- Dump Cart
- 36" & 42" Snowthrower
- PTO Driven Vacuum Collector
- 38" Tiller
- Tire Chains
- Snow Cab
- Wheel Weights

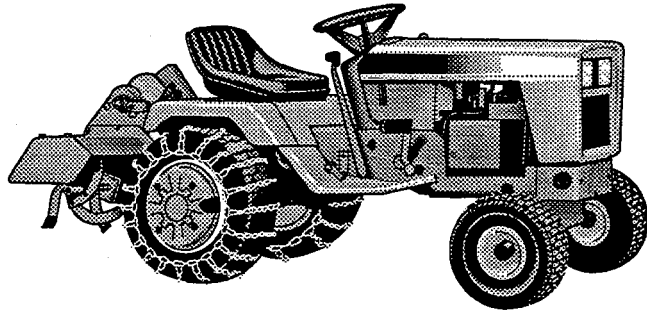

TECHNICAL LITERATURE

Manuals are fully illustrated. All of the assemblies are shown in exploded views which show the relationship of the parts and how they go together. Important assembly notes and special torque values are included in the illustrations. Standard hardware and torque specification charts are also included.

For the manuals applicable for your model, contact the Customer Publications Department at 414-284-8519. Have the following information available when phoning in your request.

Model: _____
Mfg. No.: _____
Your Name: _____
Address: _____
City, State, Zip: _____
Visa/Mastercard No.: _____
Card Expiration Date: _____



International Symbols



Fast



Slow



Operator Present
Switch (Seat)



PTO Engaged



Lights



Oil Pressure



Forward



Reverse



Parking Brake



Choke



Engine Running

Notes

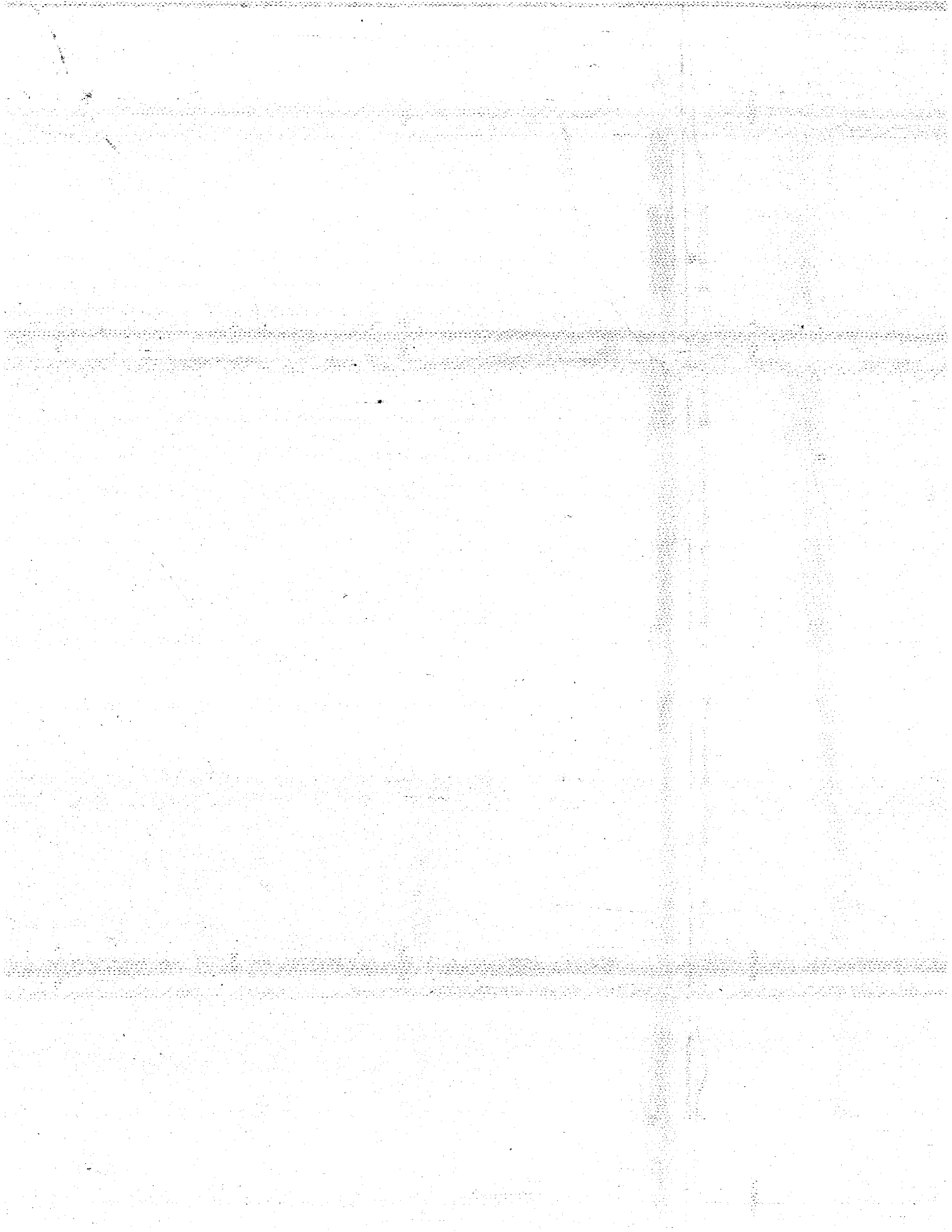



MASSEY FERGUSON
LAWN & GARDEN EQUIPMENT

Massey Ferguson Lawn & Garden Equipment
is Manufactured and Distributed by Simplicity Manufacturing, Inc.
500 N. Spring Street • P.O. Box 997 • Port Washington, WI 53074-0997 USA

Form Nos. 1715791-00
1714410-01

Rev. 5/96
© Copyright 1996 Simplicity Manufacturing, Inc.
All Rights Reserved. Printed In USA.
TP 100-2004-02-SV-M