



# MODEL T10252 DUST PORT FOR G1183/G1276 INSTRUCTIONS

## Introduction

The Model T10252 Dust Port helps capture dust from the disc sander on the G1183/G1276 Combination Sanders that were manufactured before August, 2010.

### NOTICE

The installation of the dust port requires that you remove the lower disc guard from the sander and modify it. Read through this entire document before beginning the installation procedure on the next page.

## Shipping Inventory (Figure 1)

- A. Dust Chute ..... 1
- B. Phillips Head Screws #10-24 x 3/8" ..... 2
- C. Hose Clamps 1 1/2" ..... 2
- D. Dust Hose 1 1/2" x 10" ..... 1
- E. Hose Adapter 2 1/2" x 1 1/2" ..... 1
- F. Cover Plate ..... 1
- G. Flat Washers 5/16" ..... 2
- H. Hex Bolts 5/16-18" x 12" ..... 2

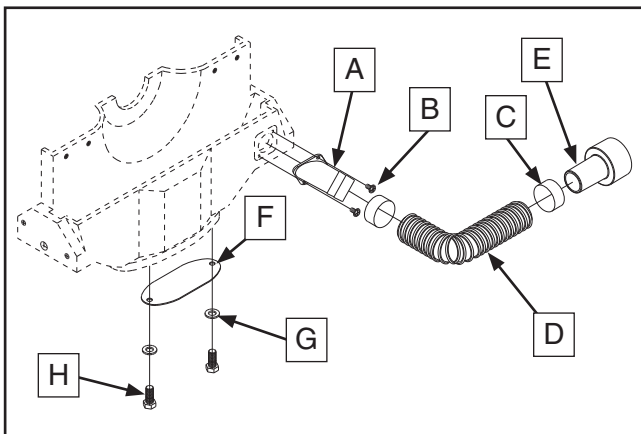


Figure 1. Model T10252 shipping inventory.

## Dust Collection

The included dust collection hose assembly has a 2 1/2" adapter for connection to your dust collection system.

### CAUTION

DO NOT operate the Model G1183/G1276 sander without an adequate dust collection system. This sander creates substantial amounts of wood dust while operating. Failure to use an adequate dust collection system can result in short and long-term respiratory illness.

### Recommended CFM at Dust Port: 150 CFM

Do not confuse this CFM recommendation with the rating of the dust collector. To determine the CFM at the dust port, you must consider these variables: (1) CFM rating of the dust collector, (2) hose type and length between the dust collector and the machine, (3) number of branches or wyes, and (4) amount of other open lines throughout the system. Explaining how to calculate these variables is beyond the scope of this manual. Consult an expert or purchase a good dust collection "how-to" book.

If you need help with your dust port, call our Tech Support at: (570) 546-9663.

COPYRIGHT © NOVEMBER, 2010 BY GRIZZLY INDUSTRIAL, INC.  
WARNING: NO PORTION OF THIS MANUAL MAY BE REPRODUCED IN ANY SHAPE  
OR FORM WITHOUT THE WRITTEN APPROVAL OF GRIZZLY INDUSTRIAL, INC.

#TS13350 PRINTED IN TAIWAN

## Installation

In order to attach the dust port, you need to remove the cast aluminum lower disc guard, create a  $1\frac{3}{8}$ " hole in it, and tap two #10-24 holes near this hole for attaching the dust port. If you are not experienced with these tasks, get assistance from someone who is to reduce the risk of personal injury or damaging the lower disc guard.

Tools Needed	Qty
Another Person.....	1
Phillips Screwdriver .....	1
Dead Blow Hammer or Rubber Mallet .....	1
Open-End Wrench 10mm.....	1
Wrench or Socket $\frac{1}{2}$ " .....	1
Hex Wrench 3mm.....	1
Hex Wrench 6mm.....	1
Hex Wrench 8mm.....	1
Electric Drill .....	1
Bi-Metal Hole Saw $1\frac{3}{8}$ " .....	1
Marker .....	1
Drill Bit #25.....	1
Tap #10-24.....	1

**Note:** Go to [Grizzly.com](http://Grizzly.com) or call Customer Service at (800) 523-4777 to order the following tools:

**H0886—Bi-Metal Hole Saw  $1\frac{3}{8}$ "**

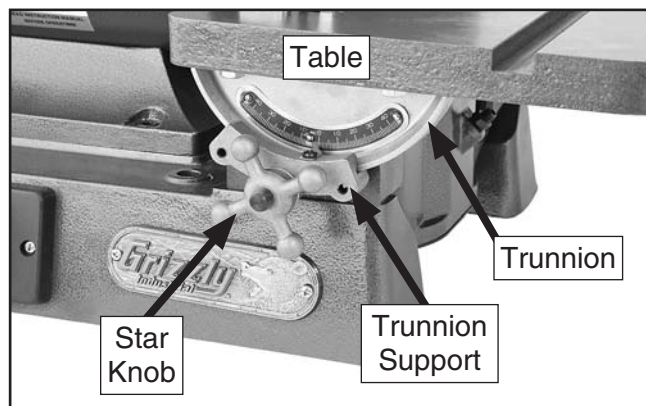
**H0904—Hole Saw Arbor  $\frac{5}{8}$ "**

**T20680—Irwin 3-Pc. Tap Set #10-24**

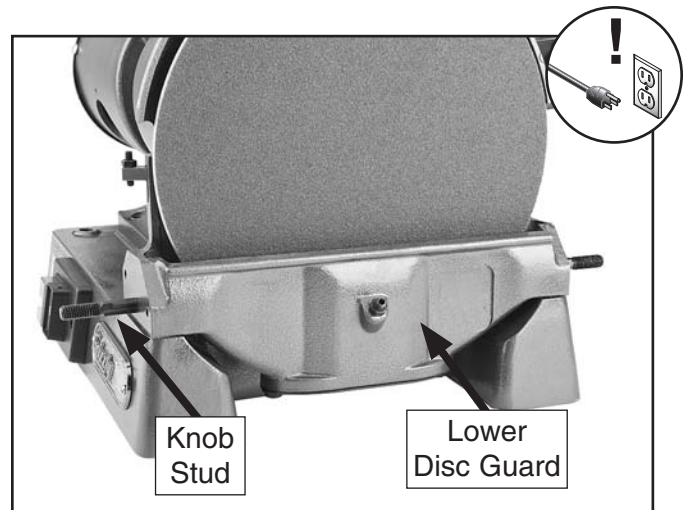
**H2717—2-Pc. Mini Tap Handle Set**

**To install the dust port onto the sander:**

1. DISCONNECT SANDER FROM POWER!
2. Remove both star knobs that secure the disc sander table (see **Figures 2–3**), slide the trunnion supports off the knob studs, then remove the table.

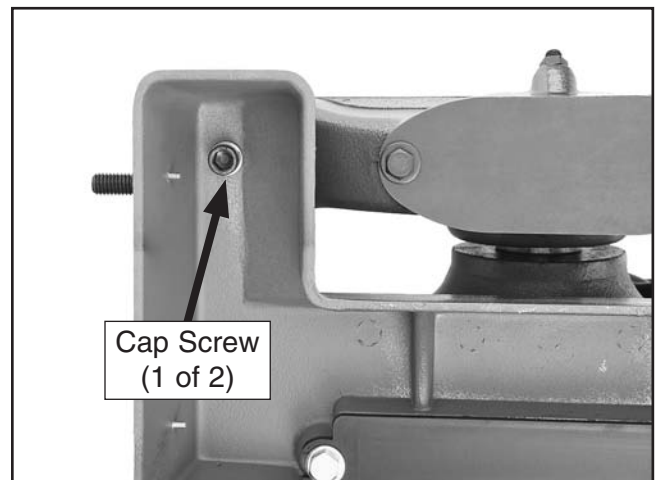


**Figure 2.** Disc sander table support components.



**Figure 3.** Disc sander table removed to expose the lower disc guard.

3. With the help from another person to steady the sander, tip it back to gain access to the two cap screws underneath the base that secure the lower blade guard, then remove these cap screws (see **Figure 4**).

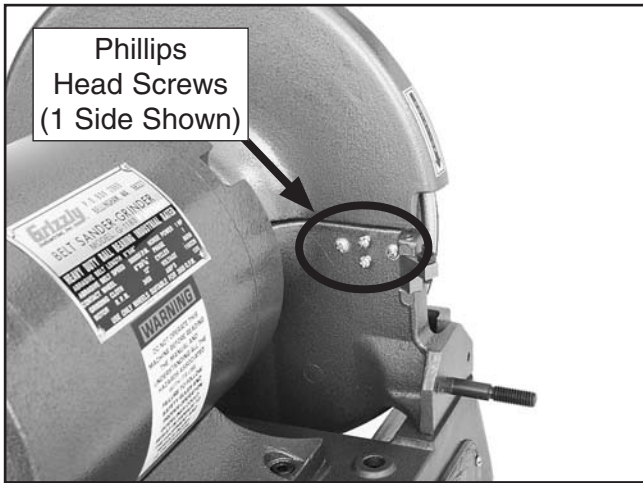


**Figure 4.** One of two cap screws that secures the lower disc guard.

4. Remove the eight Phillips head screws behind the guard that secure and adjust the upper disc guard to the lower guard, then lift the upper guard up and off (see **Figures 5–6**).

**Note:** The two inner screws of the four-screw set on either side of the disc are for adjusting the alignment of the upper guard with the lower guard. The outer screws join the guards together.





**Figure 5.** Phillips head screws that secure and adjust the guard sections.

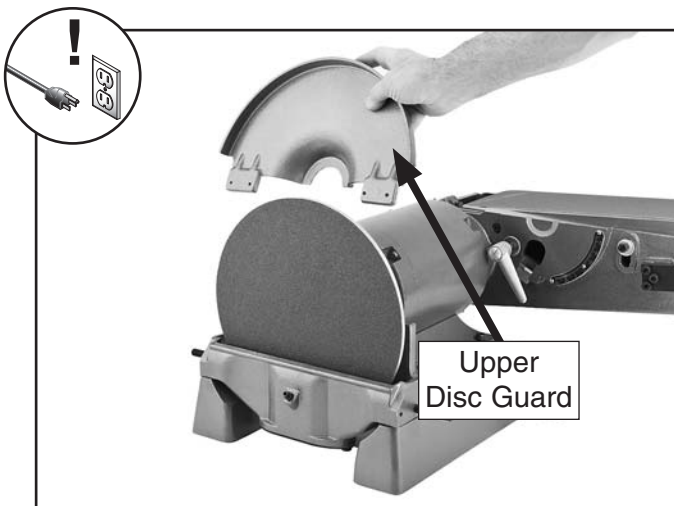
6. Take care to retain the motor shaft key, then slide the disc off the shaft. This will also remove the lower disc guard.

**Note:** It may be necessary to gently tap on the back of the disc with a dead blow hammer or rubber mallet to aid in removing it from the shaft.

7. Refer to **Figures 8–9** for the location of the 1 3/8" hole for the dust chute, then mark the location of the hole on the guard and use the bi-metal hole saw to make the hole.

**Important:** Make sure the center of this hole is 2 1/8" above the bottom of the guard, as illustrated in **Figure 9**.

**Note:** Do not drill and tap the #10-24 holes until the next step.

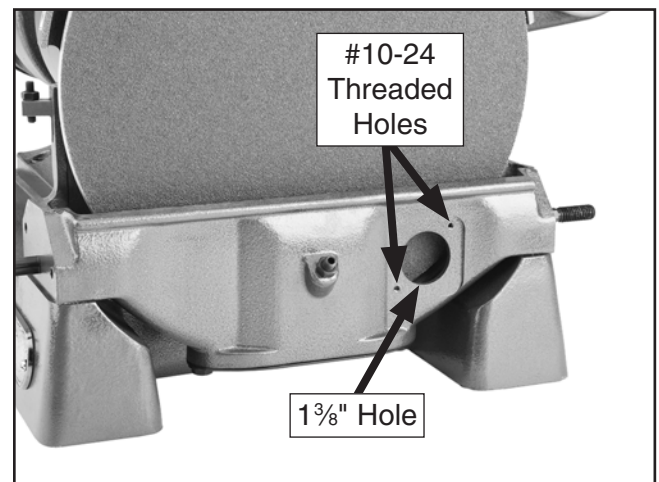


**Figure 6.** Removing the upper disc guard.

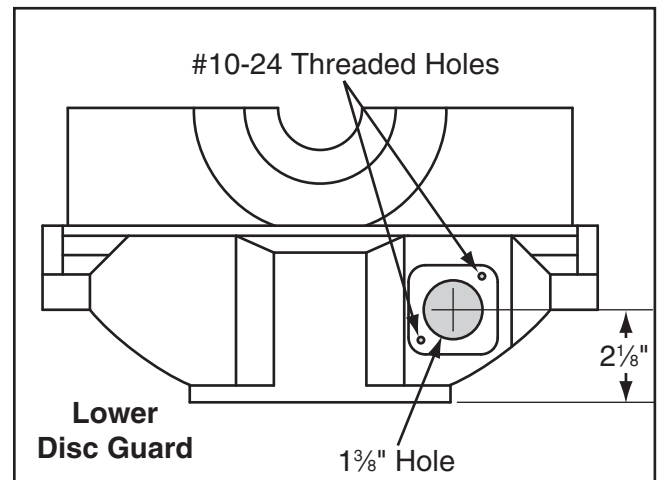
5. Fully loosen the two set screws that secure the disc to the motor shaft, as shown in **Figure 7**.



**Figure 7.** Disc set screws.



**Figure 8.** Example of hole placement with lower disc guard installed.



**Figure 9.** Illustration displaying hole locations on the lower disc guard.



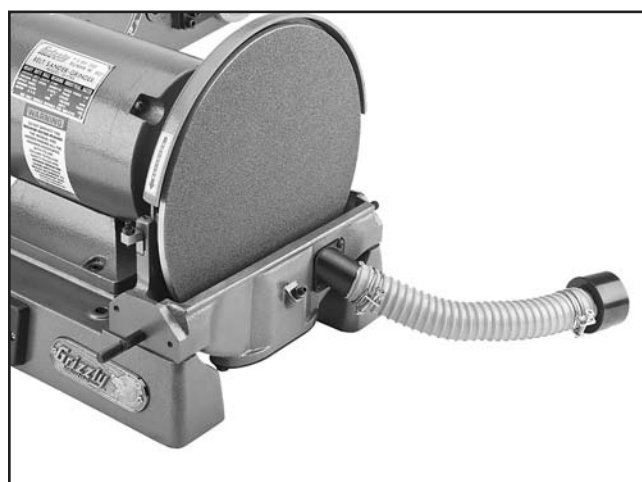
8. Position the dust chute over the hole you made in **Step 7** so that it completely covers it and is facing down and to the right, then mark the locations of the #10-24 mounting holes.
9. Remove the dust chute, then drill and tap the two #10-24 holes.
10. Secure the included cover to the bottom of the disc guard, as shown in **Figure 10**, with the (2)  $\frac{5}{16}$ "-18 x  $\frac{1}{2}$ " hex bolts and  $\frac{5}{16}$ " flat washers. This will keep the dust from escaping through the bottom of the guard.



**Figure 10.** Bottom cover installed on the lower disc guard.

11. Place the disc in the lower guard in the same manner as it was before you removed it from the sander, orient the disc bore with the shaft key, then slide it back onto the motor shaft as you position the guard over its mounting holes.
12. With the help of another person, tip the sander back until you can re-install the cap screws you removed in **Step 3** to secure the lower guard to the base.

13. Make sure the disc is fully seated on the motor shaft, then re-tighten both set screws to secure it.
14. Re-install the upper disc guard with the eight Phillips head screws that you removed in **Step 4**.
15. Thread the inner two screws from **Step 10** in or out to adjust the upper guard so that it is even with the lower guard (see **Figure 5** on the previous page).
16. Attach the dust hose assembly to the lower guard with the two #10-24 x  $\frac{3}{8}$ " Phillips head screws, as shown in **Figure 11**.



**Figure 11.** Dust hose assembly attached to the lower disc guard.

17. Re-install the disc sander table in the reverse order from which you removed it.
18. Attach the dust hose assembly to an adequate dust collection system before beginning operations.

