

INSTALLATION INSTRUCTIONS

POWER LIFT ACTUATOR ATTACHMENT
MFG. NO. 1690392

To install the Power Lift Actuator Attachment, proceed as follows:



WARNING

For your personal safety, stop tractor engine, set parking brake, and remove key to prevent accidental starting.

1. Remove tractor steering wheel (capscrew, flange locknut, and, on some units, the spacing washers).
2. Raise hood and disconnect negative battery cable. Fasten negative cable away from battery.
3. Remove the upper dash assembly (4 phillips head screws). See figure 1.

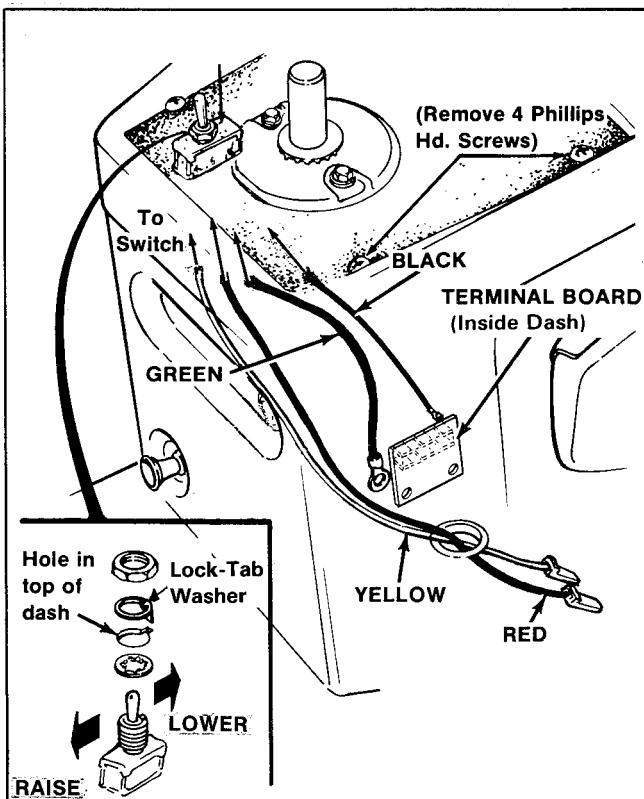

Figure 1.

4. Remove the rear-most plug from top of dash. Install the toggle switch so the black and green wires are toward rear of tractor (figure 1). Use the starwasher and nut as shown in box in figure 1. Some switches also have a lock-tab washer; install it so tab fits in slot as shown.
5. Connect dark green wire (ground wire) from toggle switch to mounting hardware for the terminal board inside the dash. Connect black wire from switch to any open post on terminal board.
6. Route red and yellow wires down through hole in tractor frame. See figure 1.
7. Attach the power lift support assembly to underside of frame with four 3/8"-16 x 3/4" self tapping screws. See figure 2. The capscrews and lockwashers are installed from outside of frame into threaded holes of support assembly.

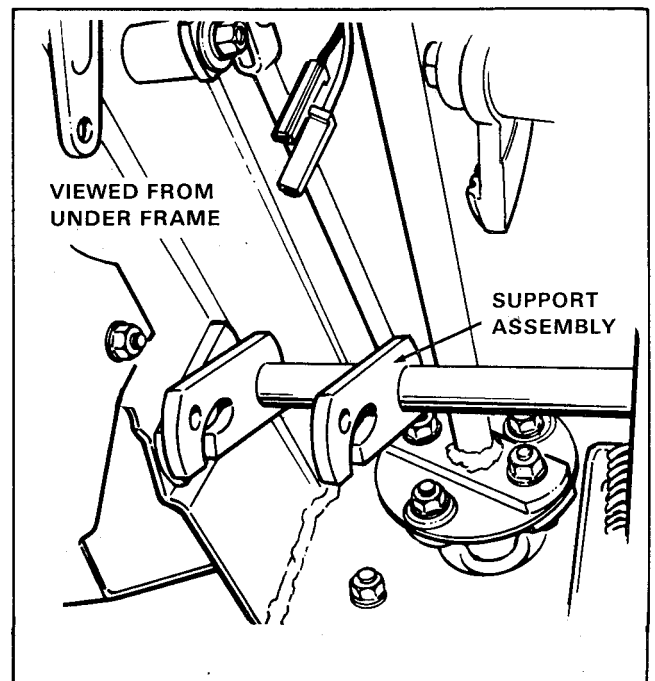

Figure 2.

8. Slip the studs of power actuator assembly into the curved slots of the support assembly just installed. See figure 3.
9. Secure the actuator assembly to the support assembly with the 5/16"-18 x 3-1/4" capscREW and locknut provided.

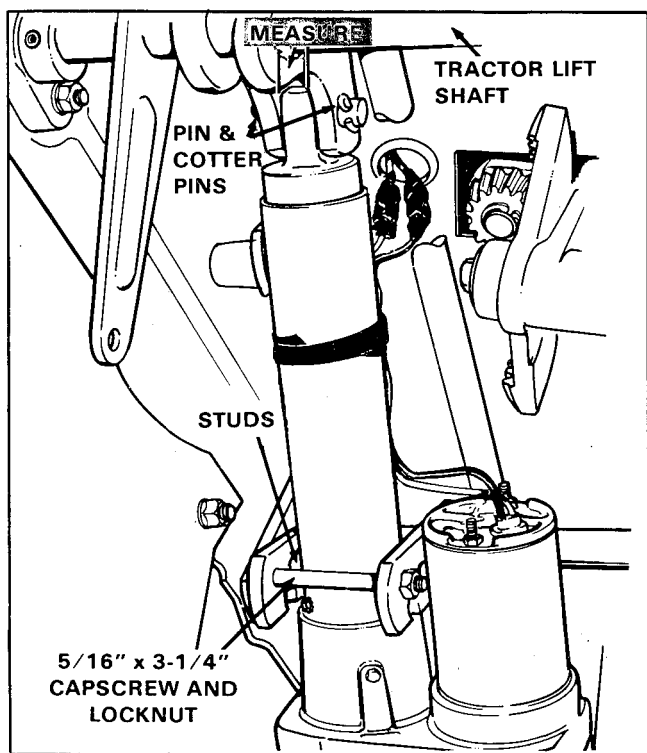

Figure 3.

10. Two pins (items J & K, figure 6) are included in the kit. Only one will be used. To determine which pin to use, measure the distance between the ears on the tractor lift shaft shown in figure 3. If the distance measures approx. 1-1/8", use pin no. 171690 which has only one hole. If the distance measures approx. 1 1/16", use pin no. 171025 which has a hole in each end. To install pin 171690, perform step "a". To install pin 171025, perform step "b".
 - a. Connect the actuator ram to the ears of the tractor lift shaft by inserting the pin from the right-hand side. See figure 3. Install the cotter pin and bend the legs fully.
 - b. Connect actuator ram to the ears of the tractor lift shaft with pin and two cotter pins. See figure 3.

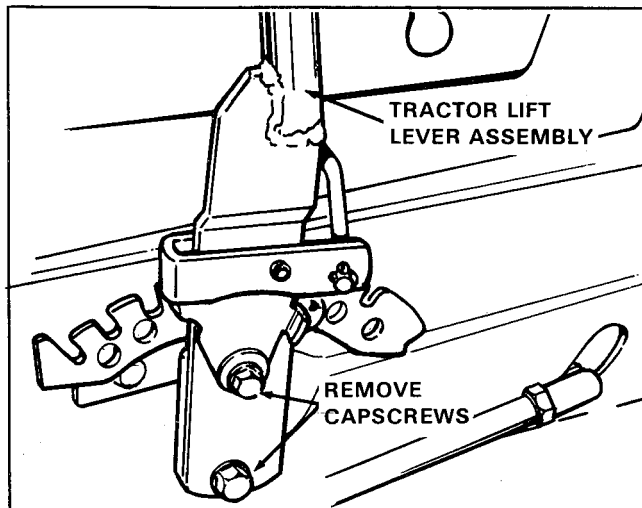

Figure 4.

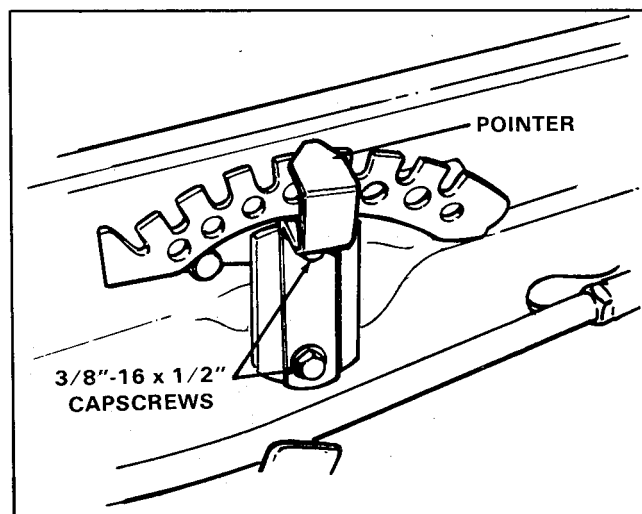

Figure 5.

11. Connect the red wire from the switch harness to the red wire from the actuator motor. Connect the yellow wire from the switch harness to the remaining wire from the actuator motor.
12. Tape wires to actuator cylinder so they will not tangle in any mechanism. See figure 3.
13. Remove the tractor lift lever assembly. See figure 4.
14. Replace the lift lever with the pointer provided (see figure 5). Install pointer with two 3/8"-16 x 5/8" cap screws provided (use lockwashers from lift lever removal). During operation, the pointer allows you to determine lift movement and position and also acts as a stop.

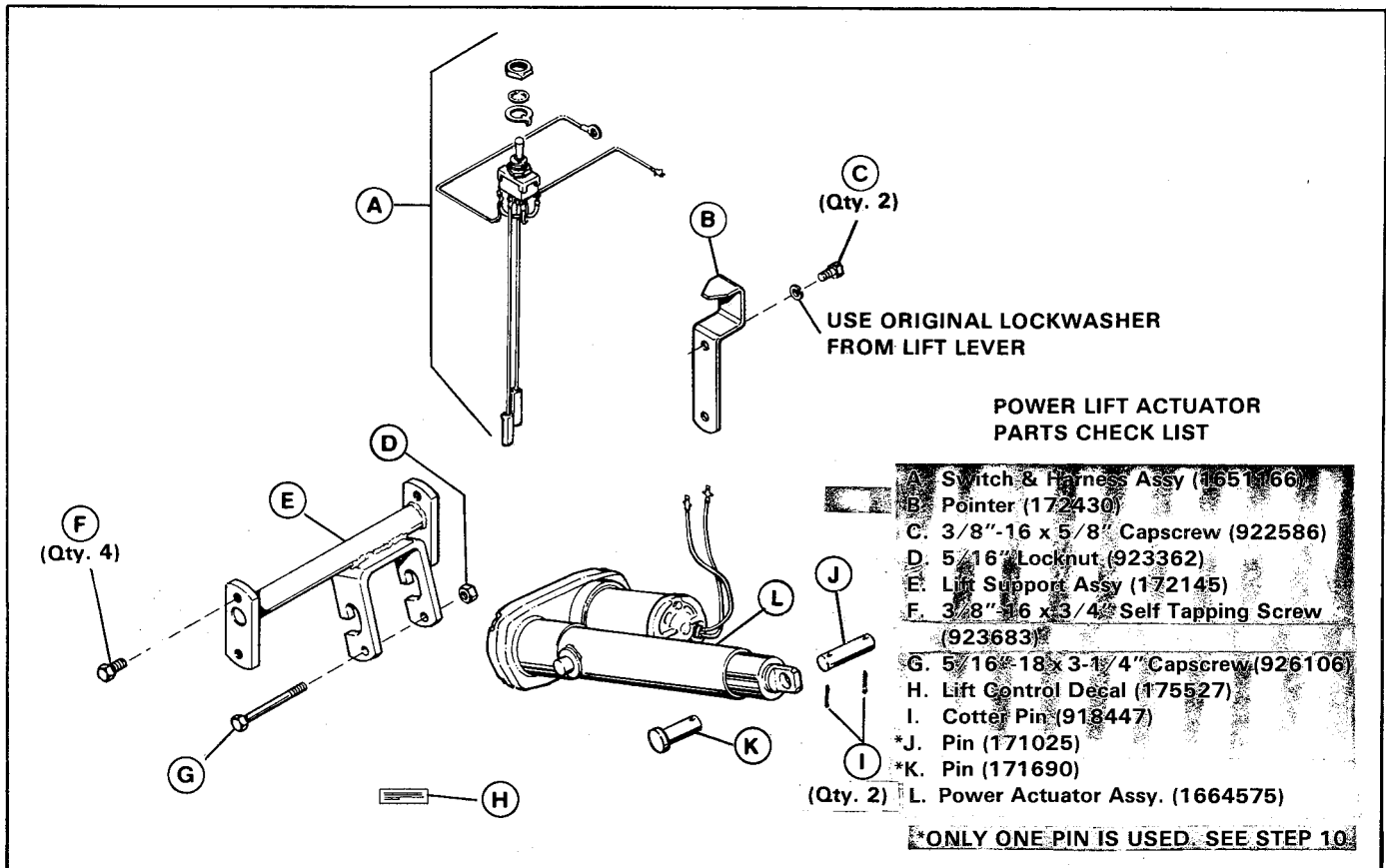

Figure 6.

15. Reinstall negative battery cable.
16. Turn ignition key to accessory position.
17. Test operate power lift to be sure of wiring connections. Actuation of control switch by moving toggle lever toward operator should cause pointer in figure 5 to move toward rear of quadrant. If pointer moves toward front, reverse wire connections to actuator motor made in step 11. **Remove key after test.**
18. Reinstall upper dash and steering wheel.
19. Apply "Lift Control" decal at power lift toggle switch. Be sure surface is clean and dry.