

INSTALLATION INSTRUCTIONS

36 INCH MOWER BAFFLE KIT

MFG. NO. 1685188

REPLACES BAFFLE 1654551



WARNING

To prevent personal injury, avoid contact with the cutting edge of the blades.

KIT PARTS

This kit consists of the following parts.

Part Name	Part Number	Qty.
"L" Bracket	1668500	1
Baffle	1668362	1
Roller Bracket	1668361	1
Capscrew, 5/16x1.25	921977	1
Lockwasher, 5/16	917356	1
Nut, 5/16	917372	1
Screw, Taptite 1/4x3/4	925592	1
Lockwasher, 1/4	916964	1
Nut, 1/4	916622	1

PROCEDURE

NOTE

In these instructions, "rear" always refers to the side opposite the hitch. "Top" always refers to the side with pulleys.

1. Remove the mower from the vehicle. Follow the removal procedure in the Operator's Manual, if necessary.
2. For mowers with manufacturer's number 1690274 or 1690627 only, remove the eight carriage bolts, lockwashers and nuts which hold the support assembly to the mower deck (figure 1). (This will provide clearance to remove baffle hook screw in next step.)

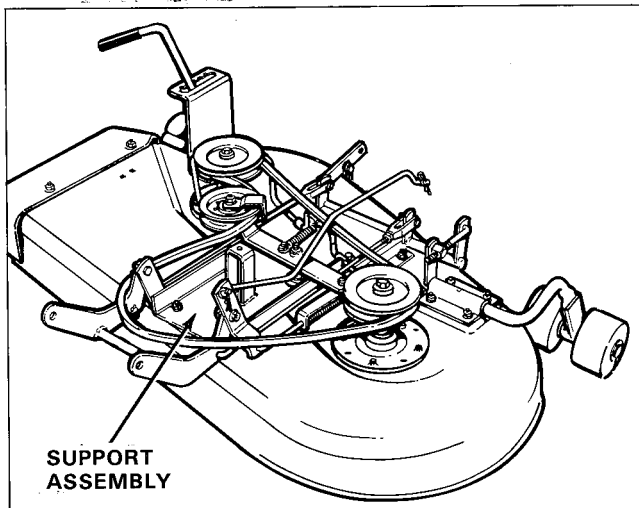

Figure 1. Mower Support Assembly,
Mfg. No. 1690274 Only

3. Remove the old baffle assembly as follows.
 - a. Remove the four carriage bolts, lockwashers and nuts which hold the baffle assembly to rear of mower deck. (These fasteners will be used to install the new baffle.)
 - b. Remove the locknut and washer from the baffle hook screw which holds front end of baffle to mower deck. (For mowers with mfg. no. 1690274 or 1690627, raise the support assembly enough to remove locknut and washer.)
4. Remove the roller from the baffle by prying off the E-ring from each end of shaft. Push the shaft out of the roller and bracket. (The roller, shaft and E-rings will be installed in the new baffle.)
5. Assemble the "L" bracket (A, figure 2) and roller bracket (B) to the baffle (C) as shown with one 1/4 inch taptite screw, lockwasher and nut supplied with kit.
6. Position the roller in the bracket (B) and slide the shaft (D) thru the bracket and roller. The shaft will fit only one way due to hole with flat side (F). Install an E-ring in each end of shaft, making sure the E-rings are fully seated in grooves.

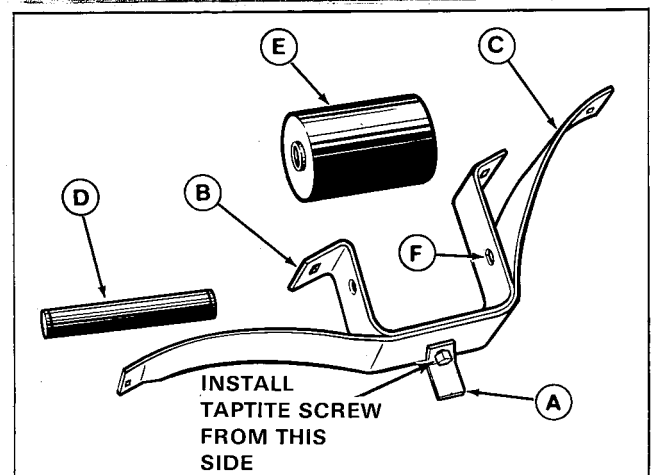

Figure 2. Baffle Assembly

- A. "L" Bracket
- B. Roller Bracket
- C. Baffle
- D. Roller Shaft
- E. Roller
- F. Hole with flat side

7. Position the baffle assembly in the mower as shown in figure 3. Align the four mounting holes with the four holes in the rear side of the mower deck. If the "L" bracket aligns with a bolt already installed, perform step "a". If there is no hole in the deck for the "L" bracket, perform step "b".
 - a. Remove the bolt, lockwasher and nut which aligned with the "L" bracket. Reposition the baffle and attach the "L" bracket to the deck with the fasteners just removed. Install the baffle to rear of mower deck with the four carriage bolts, lockwashers and nuts that were removed in step 3a.
 - b. Install the baffle to rear of the mower deck with the four carriage bolts, lockwashers and nuts removed in step 3a. Mark the mower deck thru center of hole in "L" bracket and then drill a 11/32 inch (8.7 mm) hole. To secure the "L" bracket to the deck, insert the 5/16 inch cap-screw from kit thru the "L" bracket and deck. Install the lockwasher and nut from top of the deck.

8. For mowers with mfg. no. 1690274 or 1690627 only, reinstall the support assembly with the eight carriage bolts, lockwashers and nuts. Be sure to install bolts from bottom. Install the front two bolts first. To install the rear most bolts, the baffle or roller will need to be removed for clearance. Do not remove the roller which holds the "L" bracket (C, figure 3) to the deck. After installing the support assembly, reinstall any removed parts.
9. Make sure all nuts are securely tightened.

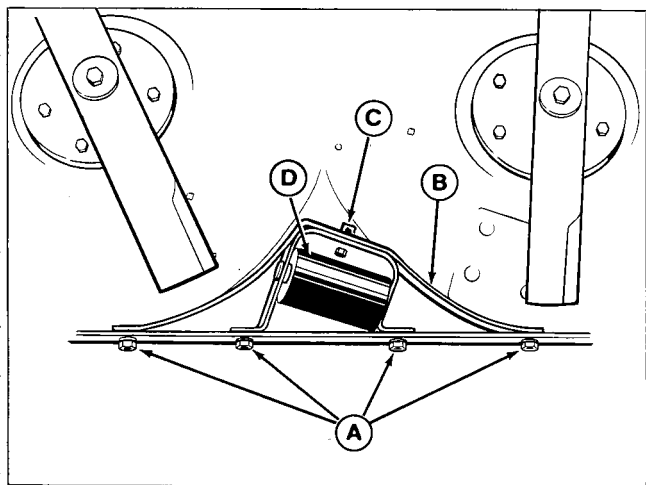

Figure 3. Baffle Positioned in Mower

- A. Nuts & Lockwashers
- B. Baffle
- C. "L" Bracket
- D. Roller