

1300 SERIES

Front-Cut
Riding Mowers

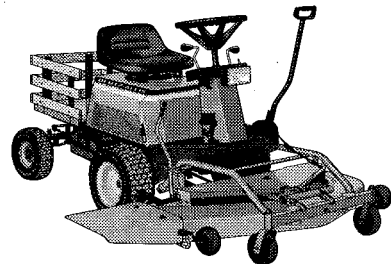

AGCO ALLIS

This manual covers the following Manufacturer's Numbers:

1312G42: 12 HP GEAR
Mfg. No. 1691658

42" MOWER
Mfg. No. 1691665

1312H42: 12 HP HYDRO
Mfg. No. 1691659

42" MOWER
Mfg. No. 1691665

1313H42: 12.5 HP HYDRO
Mfg. No. 1692021

42" MOWER
Mfg. No. 1691665

1316H48: 16 HP HYDRO
Mfg. No. 1691660

48" MOWER
Mfg. No. 1691666

Contents

SAFETY RULES	2	TROUBLESHOOTING	34
DECALS	4	Battery Replacement	38
OPERATION	6	Jump Starting with Auxiliary Battery	38
Controls	6	Mower Belt Replacement	40
Engine Compartment	10	Power Unit Belts	41
Safety Interlock System	12	ADJUSTMENTS	46
Checks Before Starting	13	Seat Adjustment	46
Starting and Stopping	14	Neutral Adjustment - Hydro	47
Clutch/Brake Pedal Operation	15	Clutch/Brake Adjustment - Hydro	48
Mowing Pattern & Tips	16	Clutch/Brake Adjustment - Gear	49
Pushing Rider By Hand	16	Chain Adjustment - Gear	49
NORMAL CARE	10	PTO Clutch Adjustment	50
Normal Care Schedule	18	Mower Leveling	52
Storage	19	SPECIFICATIONS	54
Lubrication	19	COMMON REPLACEMENT PARTS	56
Tire Pressure	24	OPTIONAL ATTACHMENTS & ACCESSORIES	57
Battery Maintenance	24	PARTS MANUAL AVAILABLE	59
Check Transmission Fluid Level	26		
Mower Removal & Installation	27		
Servicing the Mower Blades	32		

NOTE

In this manual, "left" and "right" are referred to as seen from the operating position.

Safety Rules



Read these safety rules and follow them closely. Failure to obey these rules could result in loss of control of vehicle, severe personal injury to yourself or bystanders, or damage to property or equipment. The triangle  in text signifies important cautions or warnings which must be followed.

- Know the controls and how to stop quickly. **READ THIS OPERATOR'S MANUAL** and instructions furnished with attachments.
- Do not allow children to operate the machine. Do not allow adults to operate it without proper instruction.
- Do not carry passengers. Do not mow when children and others are around.
- Clear the work area of objects (wire, rocks, etc.) that might be picked up and thrown.
- Operator must be in seat with transmission in neutral and PTO disengaged before attempting to start rider engine.
- Disengage power to attachments and stop the engine (motor) before leaving the operator's position.
- Disengage power to attachments and stop the engine (motor) before making any repairs or adjustments.
- Disengage power to attachments when transporting or not in use.
- Take all possible precautions when leaving the vehicle unattended, such as disengaging the power-take-off, lowering the attachments, setting the parking brake, stopping the engine, and removing the key.
- Do not stop or start suddenly when going uphill or downhill. Mow up and down the face of steep slopes; never across the face.
- Reduce speed and exercise extreme caution on slopes and in sharp turns to prevent tipping or loss of control. Be especially cautious when changing direction on slopes.
- Stay alert for holes, rocks, and roots in the terrain and other hidden hazards. Keep away from drop-offs.
- Do not use machine to pull loads, loss of steering could occur.
- Use care when carrying loads.
 - a. limit loads to those you can safely control.
 - b. Do not turn sharply. Use care when backing.
 - c. Use counterweights or wheel weights when suggested in this Operator's Manual or Attachment Operator's Manual.
- Watch out for traffic when crossing or near roadways.

- When using any attachments, never direct discharge of material toward bystanders or allow anyone near the vehicle while in operation.
- Handle gasoline with care — it is highly flammable.
 - a. Use approved gasoline container.
 - b. Never remove the fuel cap of, or add gasoline to, a running or hot engine or an engine that has not been allowed to cool for several minutes after running. Never fill the tank indoors and always clean up spilled gasoline.
 - c. Open doors if the engine is run in the garage — exhaust fumes are dangerous. Do not run the engine indoors.
- Keep the vehicle and attachments in good operating condition, and keep safety devices in place and in working condition.
- Keep all nuts, bolts, and screws tight to be sure the equipment is in safe working condition.
- Never store the equipment with gasoline in the tank inside a building where fumes may reach an open flame or spark. Allow the engine to cool before storing in any enclosure.
- To reduce fire hazard, keep the engine free of grass, leaves, or excessive grease.
- The vehicle and attachments should be stopped and inspected for damage after striking a foreign object, and the damage should be repaired before restarting and operating the equipment.
- Do not change the engine governor settings or overspeed the engine.
- Follow these guidelines for safe operation:
 - a. Mow only in daylight or in good artificial light.
 - b. Never make a cutting height adjustment while the engine (motor) is running if the operator must dismount to do so.
 - c. Shut the engine (motor) off when removing the grass catcher or unclogging chute.
 - d. Check the blade mounting bolts for proper tightness at frequent intervals.
- Under normal usage, the grass catcher bag material is subject to deterioration and wear. Check bag frequently for deterioration and wear and replace worn bags. Check that replacement bags comply with the original manufacturer's recommendations or specifications.
- Disengage electric PTO clutch before backing up. Do not mow in reverse unless absolutely necessary and then only after observation of the entire area behind the mower.



WARNING

Do not stop or start suddenly when operating uphill or downhill. Mow up and down the face of steep slopes; never across the face. Select slow ground speed before driving onto a slope. Never operate on slopes greater than 16° which is a rise of 3 feet (0.91 meters) vertically in 10 feet (3.1 meters) horizontally.

MOWER LIFT

PULL TO
LIFT MOWER

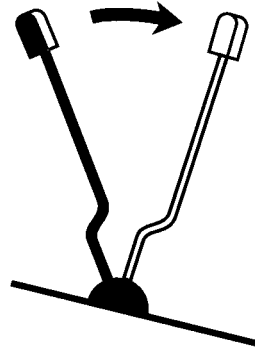

WARNING

AVOID SERIOUS INJURY OR DEATH

- READ OPERATOR'S MANUAL(S).
- KNOW LOCATION AND FUNCTION OF ALL CONTROLS.
- KEEP SAFETY DEVICES (GUARDS, SHIELDS, AND SWITCHES) IN PLACE AND WORKING.
- REMOVE OBJECTS THAT COULD BE THROWN BY THE BLADE.
- DO NOT MOW WHEN CHILDREN OR OTHERS ARE AROUND.
- NEVER CARRY CHILDREN.
- LOOK DOWN AND BEHIND BEFORE AND WHILE BACKING.
- AVOID SUDDEN TURNS.
- IF YOU CANNOT BACK UP A HILL, DO NOT OPERATE ON IT.
- GO UP AND DOWN SLOPES, NOT ACROSS.
- IF MACHINE STOPS GOING UPHILL, STOP BLADE AND BACK DOWN SLOWLY.
- BE SURE BLADE(S) AND ENGINE ARE STOPPED BEFORE PLACING HANDS OR FEET NEAR BLADE(S).
- WHEN LEAVING MACHINE, SHUT OFF ENGINE, REMOVE KEY, AND SET PARKING BRAKE.

IGNITION SWITCH

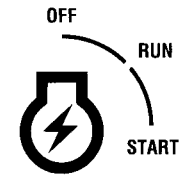

CLUTCH & BRAKE

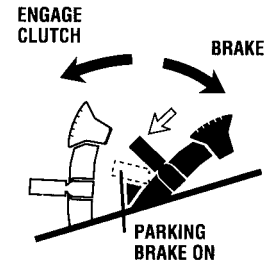

NO RIDERS

⚠ WARNING



- DO NOT STOP OR START SUDDENLY WHEN OPERATING UPHILL OR DOWNHILL
- MOW UP AND DOWN THE FACE OF STEEP SLOPES; NEVER ACROSS THE FACE
- SELECT SLOW GROUND SPEED BEFORE DRIVING ONTO A SLOPE
- NEVER OPERATE ON SLOPES GREATER THAN 16° WHICH IS A RISE OF 3 FEET (0.9 METERS) VERTICALLY IN 10 FEET (3.1 METERS) HORIZONTALLY

⚠ DANGER



**ROTATING CUTTING BLADE
DO NOT PUT HANDS
OR FEET UNDER
MOWER DECK WHILE
BLADE IS ROTATING.**

⚠ DANGER



**ROTATING CUTTING BLADE
DO NOT OPERATE MOWER
WITHOUT DEFLECTOR
OR ENTIRE GRASS
CATCHER IN PLACE.**

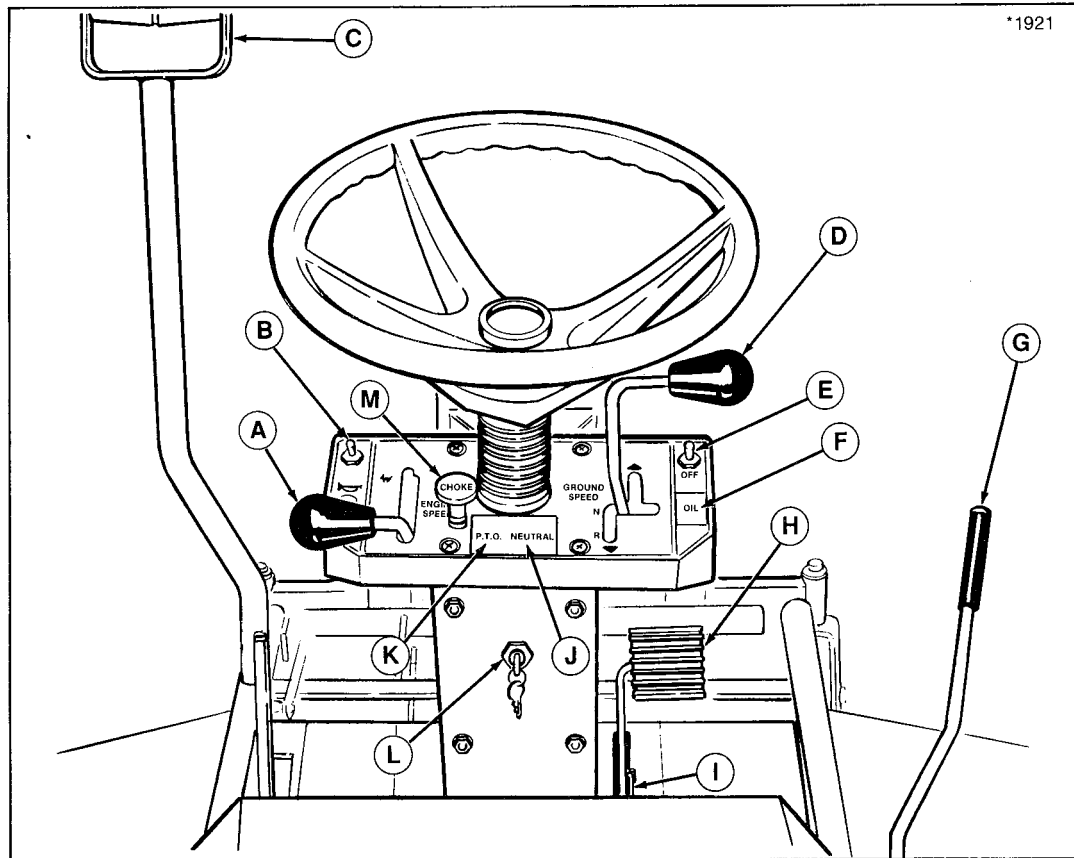

6

Figure 1. Controls - Hydrostatic Drive

Operation

ITEM	NAME	FUNCTION
A	Engine Speed Control Lever	Controls engine speed. On 12 HP, push fully forward to close choke.
B	Headlight Switch	Push forward to turn headlight on, pull back to turn headlight off.
C	Traction/Mower Transport Lever	Raises mower for transport. Pull back slightly to transfer weight of mower deck onto front drive wheels for additional traction.
D	Transmission Control Lever	Controls ground speed and forward/reverse motion. Push forward to go forward. Pull back to go in reverse. Ground speed is controlled by how far lever is in forward or reverse gate.
E	Electric PTO Switch	Controls PTO clutch for mowing. Pull up and push forward to engage mower, pull backwards to disengage. Activates PTO light, item K.
F	Oil Pressure Light (Red) (16 HP Only)	Indicates low oil pressure (when engine is running). Lights up with ignition key (L) turned on. Should go out immediately after engine starts.
G	Mower Height Adjustment Lever	Controls height of mower cut. Seven cutting heights from 1-1/4" to 4". Place in forward slot for lowest cut.
H	Clutch/Brake Pedal	Press down to disengage drive and engage brake. Release to engage drive.
I	Parking Brake Lever	Locks brake. Depress pedal (H), then latch lever over edge of frame.
J	Neutral Light (Green)	Indicates transmission lever (D) is in neutral gate. Must be lit for engine to start.
K	PTO Light (Red)	Indicates electric PTO switch (E) is on. Must be off for engine to start.
L	Ignition Switch	Starts and stops engine.
M	Choke (16 HP Only)	Pull out to close choke. Aids in starting a cold engine.

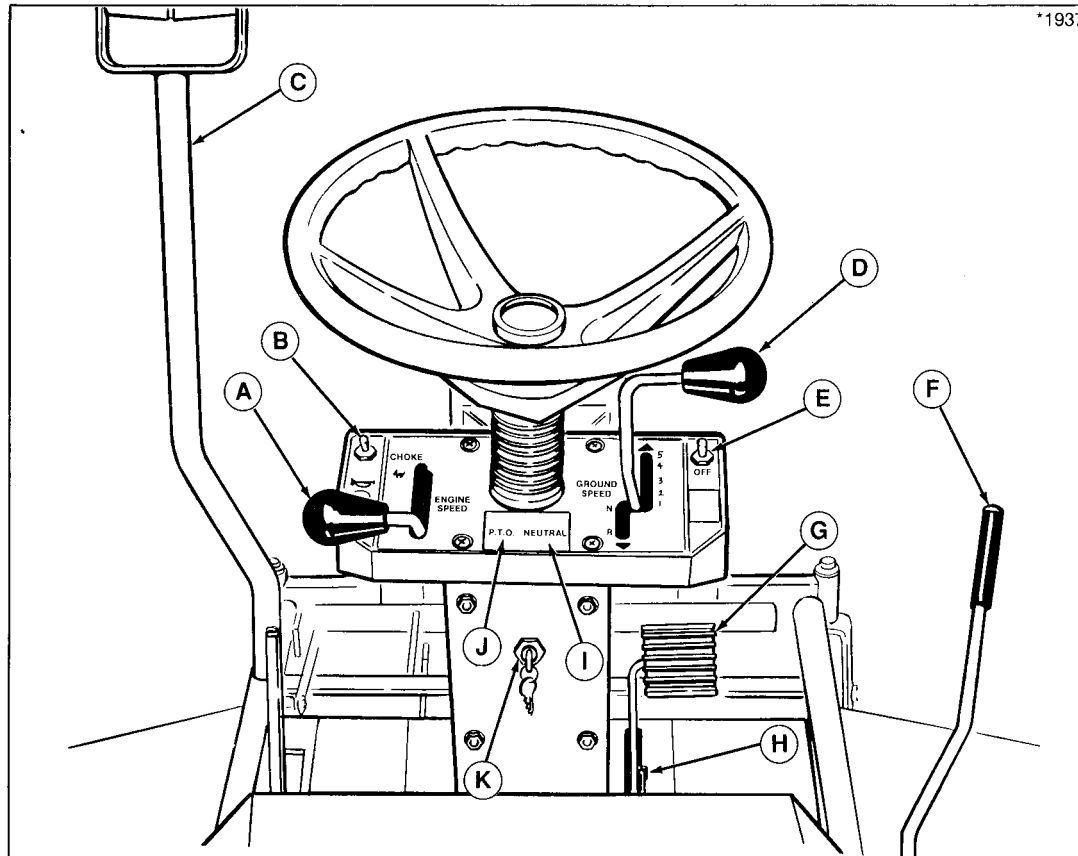
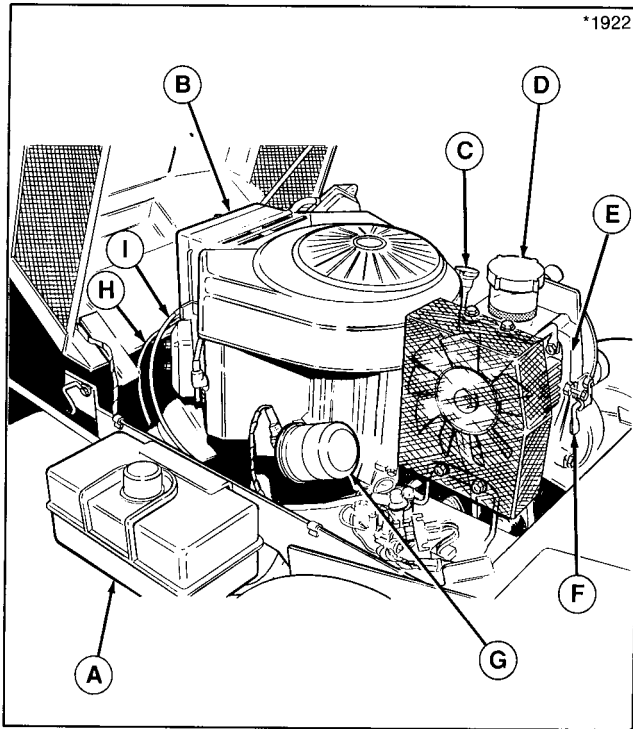

Figure 2. Controls - Gear Drive

Operation

ITEM	NAME	FUNCTION
A	Engine Speed Control Lever	Controls engine speed. Push fully forward to close choke.
B	Headlight Switch	Push forward to turn headlight on, pull back to turn headlight off.
C	Traction/Mower Transport Lever	Raises mower for transport. Pull back slightly to transfer weight of mower deck onto front drive wheels for additional traction.
D	Transmission Lever	Gear lever controls ground speed and forward/reverse motion. Depress clutch pedal (G) and push forward/back to select gear. Five forward speeds and one reverse speed.
E	Electric PTO Switch	Controls PTO clutch for mowing. Pull up and push forward to engage mower, pull backwards to disengage. Activates PTO light, item J.
F	Mower Height Adjustment Lever	Controls height of mower cut. Seven cutting heights from 1-1/4" to 4". Place in forward slot for lowest cut.
G	Clutch/Brake Pedal	Press down to disengage drive, shift gears and engage brake. Release to engage drive.
H	Parking Brake Lever	Locks brake. Depress pedal (G), then latch lever over edge of frame.
I	Neutral Light (Green)	Indicates transmission lever (D) is in neutral gate. Must be lit for engine to start.
J	PTO Light (Red)	Indicates electric PTO switch (E) is on. Must be off for engine to start.
K	Ignition Switch	Starts and stops engine.



**Figure 3. 16 HP Engine Compartment
(Hydro Drive Shown)**

ITEM	NAME	DESCRIPTION
A	Fuel Tank (RH Side Shown)	One gallon fuel tank on each side of rider. Tanks drain evenly. Shut-off valve located underneath each tank.
B	Air Filter	See Engine Manual for maintenance instruction.
C	Oil Fill/ Dipstick	Turn and remove to add oil. See Engine Manual for dipstick instruction.
D	Hydro Reservoir	Hydro models only. Fill with fluid to "FULL COLD" mark.
E	Hydro Pump	Belt-driven pump provides power through chain to front drive axle.
F	Hydro Release Valve Lever	Engages/disengages hydro pump to drive or push rider. Refer to page 16 for more information.
G	Oil Filter	Spin-on oil filter for easy maintenance. Refer to Engine Manual for recommended service intervals and procedures.
H	Throttle Cable	Controls engine speed and RPM level. See Engine Manual for adjustment.
I	Choke Cable	Controls choke position. See Engine Manual for adjustment.
OPPOSITE SIDE - NOT ILLUSTRATED		
	Seat Deck Support Arm	Supports seat deck when raised for engine maintenance and service. Must be unlatched to lower seat deck.
	Oil Drain	Oil drain extension tube allows for engine oil to be drained from underneath rider frame.

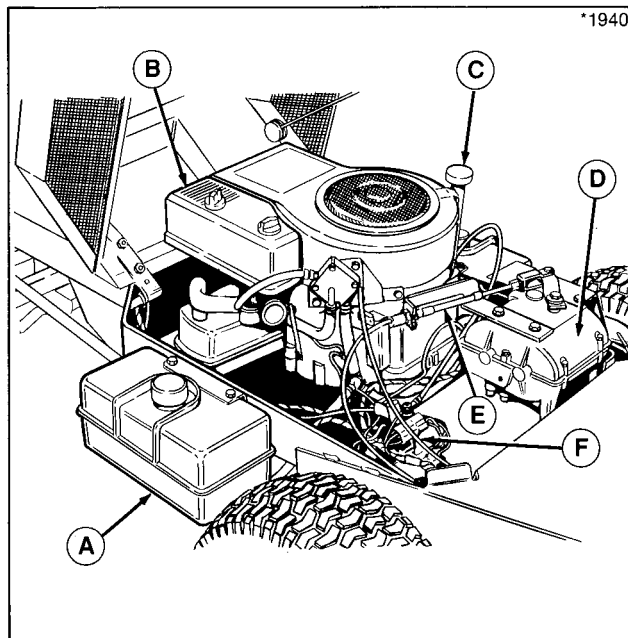

Figure 4. 12 HP Engine Compartment
(Gear Drive Shown)

ITEM	NAME	DESCRIPTION
A	Fuel Tank (RH Side Shown)	One gallon fuel tank on each side of rider. Tanks drain evenly. Shut-off valve located underneath each tank.
B	Air Filter	See Engine Manual for maintenance instruction.
C	Oil Fill/ Dipstick	Turn and remove to add oil. See Engine Manual for dipstick instruction.
D	Gear Box	5-speed gear transmission provides power to front drive axle.
E	Gear Shift Linkage	Connects gear box to dash-mounted ground speed control lever.
F	Throttle/Choke	Controls engine speed, RPM level and choke position. See Engine Manual for adjustment.
OPPOSITE SIDE - NOT ILLUSTRATED		
	Seat Deck Support Arm	Supports seat deck when raised for engine maintenance and service. Must be unlatched to lower seat deck.
	Oil Drain	Oil drain extension tube allows for engine oil to be drained from underneath rider frame.

SAFETY INTERLOCK SYSTEM

Your rider is equipped with a seat switch safety system that will automatically shut the engine off when the operator leaves the seat with the transmission lever in gear or PTO engaged. Once the engine has stopped, the electric PTO must be reset after operator returns to seat in order to engage clutch again.

Check operation of dash safety lights. With operator in seat and ignition switch turned to ON (engine not running):

- a. Neutral light should go on with transmission lever in neutral gate and should go out when lever is moved to either forward/reverse gate.
- b. PTO light should go on and off with operation of PTO switch.
- c. Oil pressure light should be on and should go out immediately after engine starts (16 HP only).

Seat Switch Tests

Check the seat switch (A, figure 5) every fall and spring with the following four tests.



WARNING

If the rider does not pass the test, do not operate rider. See your authorized dealer. Under no circumstance should you attempt to defeat the purpose of the safety system.

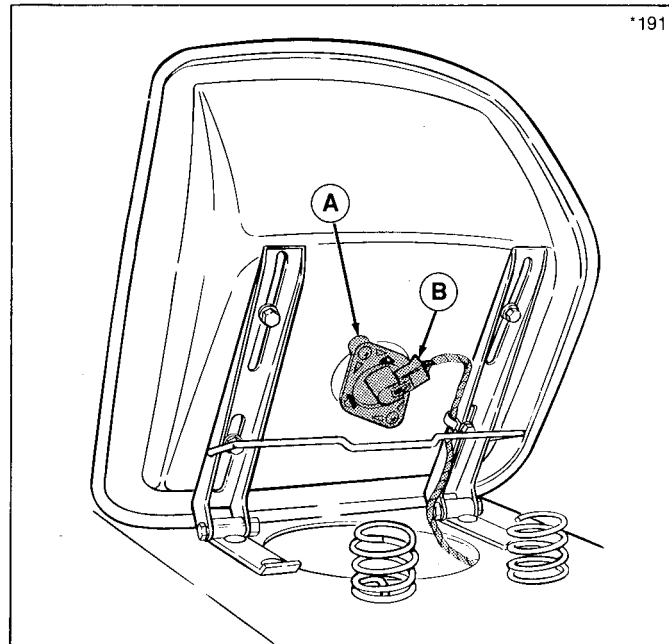

Figure 5. Seat Switch

- A. Seat Switch
B. Wiring Harness

Test 1 — Engine should NOT crank if:

- A. Seat not occupied or;
- B. Transmission lever out of neutral, or;
- C. PTO switch engaged.

Test 2 — Engine should crank if:

- A. Seat is occupied, and;
- B. Transmission lever in neutral, and;
- C. PTO switch disengaged.

Test 3 — Engine should shut off if:

- A. Operator rises off seat with transmission lever in gear, or;
- B. Operator rises off seat with PTO engaged.
- C. If operator returns to seat before engine stops, the engine will restart and electric PTO clutch will re-engage.

Test 4 — Electric clutch will disengage if:

- A. Operator rises off seat with engine running.
- B. If operator returns to seat before engine stops, the engine will restart and electric PTO clutch will re-engage.

CHECKS BEFORE STARTING



Never add gasoline when engine is hot or running.

1. Check that gas tanks (one on each side) are 3/4 full. If one tank is empty, either add gasoline, or shut off the valve on bottom of empty tank.
2. Check engine oil level and add if necessary. Refer to engine Owner's Manual for recommendations.
3. Make sure either mower deflector or grass collection system is in place.
4. Check for loose nuts, screws, bolts, oil leaks, gasoline leaks, etc.
5. Make sure the mower is in desired cutting height.
6. To operate hydro models, release valve must be disengaged. See "Pushing Rider By Hand."

STARTING AND STOPPING



WARNING

Never allow passengers to ride on the units

1. Before using this mower for the first time, the owner should operate in an open area, without mowing, to become accustomed to the unit. The unit is steered with the rear wheels, which allows very quick, tight turns. The left side of the mower can be used to trim close to objects in the lawn.
2. Make sure PTO is disengaged and transmission control lever is in neutral.
3. For cold starts, pull choke knob out (16 hp) or push engine speed control into choke position (12 hp).
For warm starts, set engine speed control between 1/2 and 3/4 throttle.
4. Turn the key to start and release when engine starts. Release choke or move lever out of choke position as engine warms.
5. Make sure desired direction is clear of objects, people and animals.
6. Before initial operation, burnish the electric clutch. Refer to "PTO Clutch Adjustment".
7. Release the parking brake.

8. Move the transmission control lever out of Neutral to travel. Push forward to go forward, or pull back to go in reverse. For gear models, depress clutch pedal, select appropriate gear for ground conditions and length of grass to be cut.
9. Place engine speed control lever to full throttle, especially if mowing thick grass. Ground speed can be controlled by placement of transmission lever (D, figure 1 or 2).
10. Select the appropriate ground speed for conditions. If the terrain is rough, hilly or sloping, drive slowly. You should also drive slowly to cut thick grass.
11. **For hydro units**, use the control lever to slow down for turns or to trim around objects, then increase speed. To stop, move the control lever into NEUTRAL position. You can also stop by depressing the the clutch/brake pedal. If you stop by depressing the pedal, move control lever to NEUTRAL before releasing pedal.
For gear units, use a lower gear to slow down for turns or to trim around objects. To stop, depress the clutch/brake pedal and shift into neutral.
12. **Before leaving operator's position**, set the parking brake and disengage the mower PTO. (The parking brake is shown set in figure 6.) Set the engine speed control to SLOW and allow the engine to idle for 20 seconds. Turn the key to OFF and remove it. Wait for moving parts to stop.

13. Clean all dirt and grass from the mower and rider. Be sure to clean the engine and transmission compartment. Allow engine to cool before touching engine parts.

WARNING

To reduce fire hazard, keep the engine, rider and mower free of grass, leaves and excess grease.

WARNING

Do not stop or start suddenly when operating uphill or downhill. Mow up and down the face of steep slopes; never across the face. Select slow ground speed before driving onto a slope. Never operate on slopes greater than 16° which is a rise of 3 feet (0.91 meters) vertically in 10 feet (3.1 meters) horizontally.

CLUTCH/BRAKE PEDAL OPERATION

Refer to figure 6. Depressing pedal from position A to B disengages transmission drive. Depressing pedal further from position B to C will also apply tractor brake. Parking brake is applied at position C when pedal is latched over footrest as shown in figure 6.

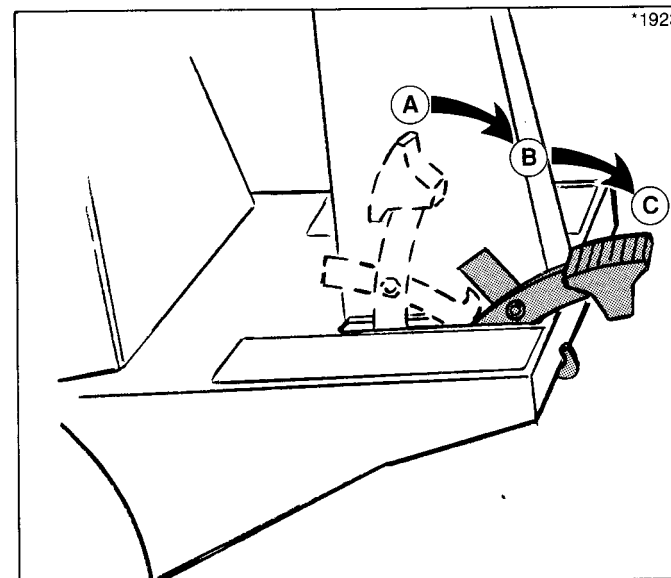

Figure 6. Clutch/Brake Pedal

MOWING PATTERN & TIPS

For the first use of the mower choose a smooth level area. Cut long straight strips overlapping slightly.

The size and type of area to be mowed determines the best mowing pattern to use. Obstructions such as trees, fences and buildings must also be considered. Where possible, make one or two passes in a clockwise direction around the outside of the area to keep cut grass off fences and walks. The remainder of the mowing should be done in a counterclockwise direction so the clippings are dispersed on the cut area.

Most lawns should be mowed to keep the grass approximately two to three inches (50 to 76 mm) high. Best results are obtained by cutting often and not too short. To help keep a green lawn, never mow more than one third of the height of the grass, or a maximum of one inch (25 mm), in one mowing. For extremely tall grass, set the cutting height at maximum for the first pass, and then reset to the desired height and mow again.

Adjust the cutting height as necessary. For best appearance, grass should be cut in the afternoon or early evening (in daylight) when it is free of external moisture.

Where possible, change patterns occasionally to eliminate matting, graining or a corrugated appearance.

PUSHING RIDER BY HAND (Hydro Drive Only)

To push the rider by hand, the hydro release valve must be engaged so that plunger on front of transmission (figure 7) is depressed. To drive the rider, the tow valve must be disengaged (figure 8).

1. To disengage, grasp lever (A, figure 7), pull toward left so lower section clears pump bracket (C). Flip down, then push toward right, so it is secured into position shown in figure 8.

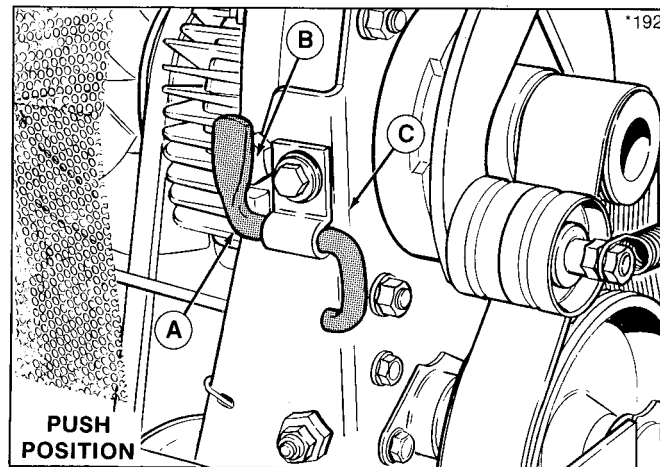

Figure 7. Hydro Release Valve Engaged
A. Lever B. Plunger C. Pump Bracket

2. To engage, grasp the lever (A, figure 8), pull toward left to clear pump bracket (C), and then flip up so it depresses plunger. Push toward right so it locks into position shown in figure 7.

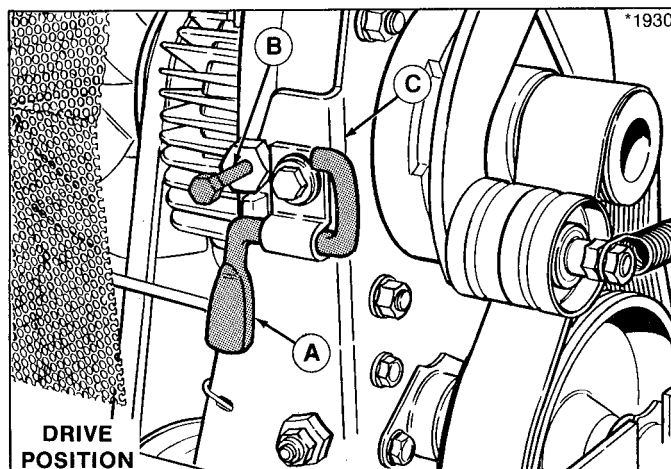

Figure 8. Hydro Release Valve Disengaged
A. Lever B. Plunger C. Pump Bracket

Normal Care

	See	Before First Use	Before Each Use	Every 5 Hours	Every 25 Hours	Every 100 Hours	Spring & Fall
Safety							
Check safety interlock system.	pg. 12	•					•
Check rider brakes.	pg. 15	•					•
Normal Care Items							
Check rider & mower for loose nuts, screws, bolts, oil leaks, etc.		•	•	•			
Check engine oil level.	Eng.Mn.	•	•	•			
Check engine & air filter.	" "				**•		
Change engine oil and filter (16 HP)*.	" "				**•		•
Lubricate rider & mower.	pg. 19				**•		
Lubricate chain.**	pg. 21		•		**•		
Check tire pressure.	pg. 24	•	•		**•		
Check transmission fluid.***	pg. 26						
Clean battery & cables.	pg. 25					•	
Clean/sharpen blades.	pg. 32					•	
Inspect spark plug(s).	Eng.Mn.					•	
<p>*Change original engine oil after first 5 hours of operation. **More often in hot (over 85° F: 30° C) weather or dusty operating conditions. ***30W oil can be used in hydro pump during extremely hot weather. Use multi-purpose transmission fluid otherwise.</p>							

Normal Care Schedule

STORAGE (30 Days or More)

1. Run rider engine until it stops from lack of fuel or, use a gasoline stabilizer. This additive, available from your dealer, prevents formation of gum and varnish for up to one year.

WARNING

Never store rider where gasoline fumes may reach an open flame or sparks.

2. Change engine oil. Record the type and weight of oil put in crankcase. See the engine Owner's Manual for recommendations.
3. Remove the spark plug(s). Squirt approximately one ounce (30 ml) of engine oil into engine through spark plug hole. Crank engine a few times to distribute oil and then reinstall the spark plug.
4. Lubricate the rider and mower.
5. Check battery fluid level. Battery life will be extended if it is removed and stored in a cool, dry place, fully charged.
6. Clean rider thoroughly. Touch up exposed metal parts with a good quality paint (obtainable from your dealer) or a light film of grease or oil.

LUBRICATION

1. With an oil can, apply a few drops of oil to points indicated with oil can in figures 9 through 18. Oil the drive chain (figures 10 and 13) with an approved chain lubricant.
2. With a grease gun, apply one or two shots of lithium based automotive grease to the grease fittings shown in the following illustrations.

Rider Lubrication

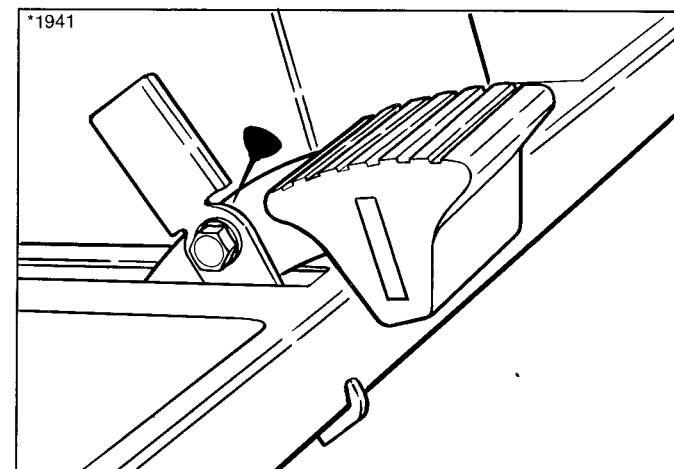

Figure 9. Lubricate Brake Pedal Pivot Point

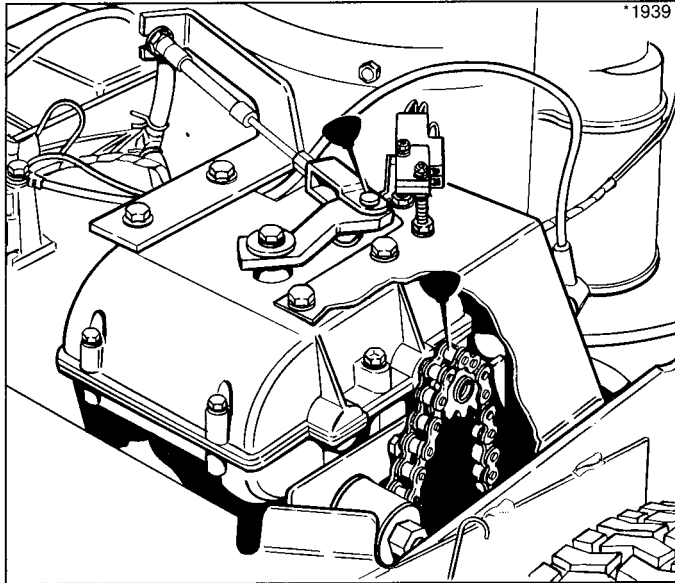

Figure 10. Lubricate Gear Shift Linkage and Chain (Gear Model Shown)

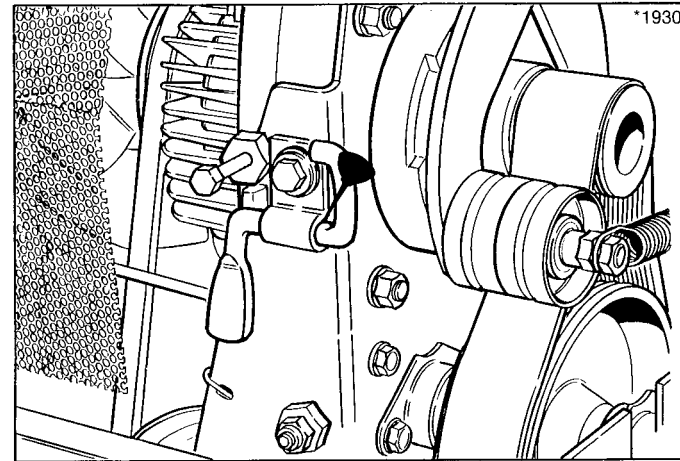

Figure 11. Lubricate Hydro Transmission Release Valve

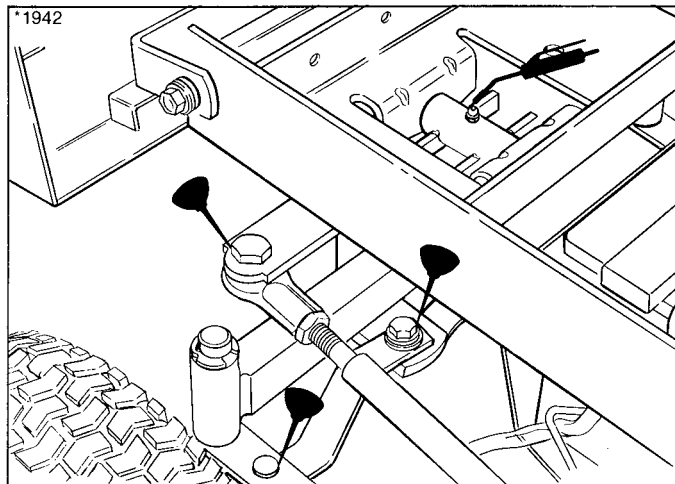

Figure 12. Lubricate Steering Arm and Axle Pivot

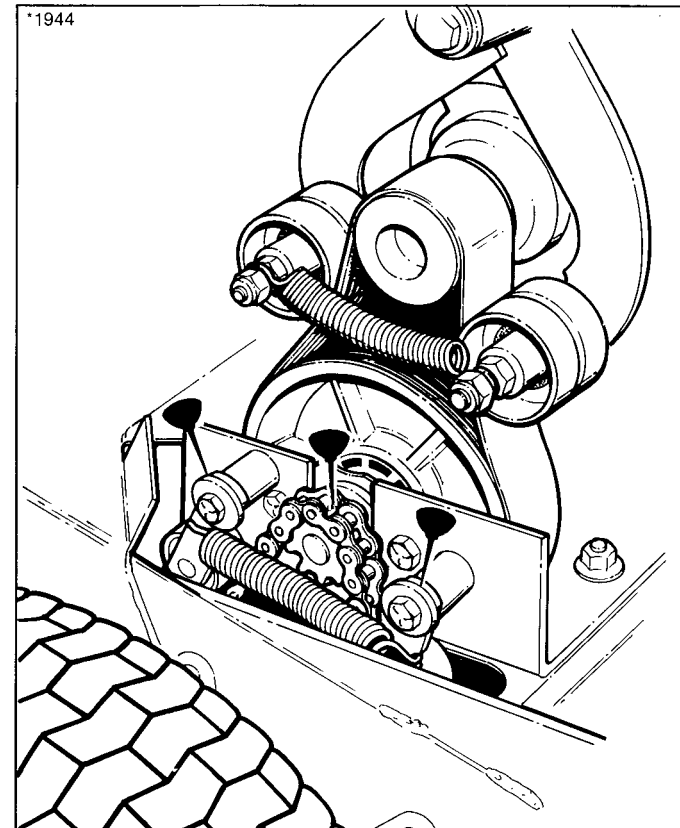

Figure 13. Lubricate Chain (Hydro Model Shown)

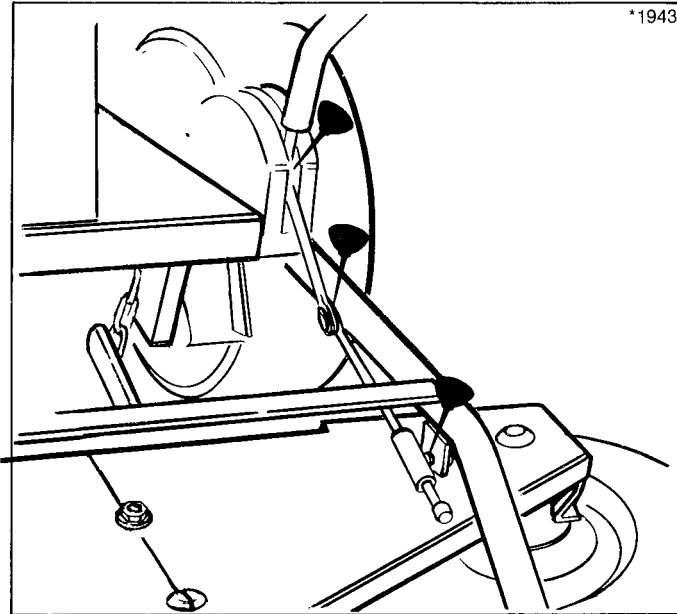

Figure 14. Lubricate Lift Lever

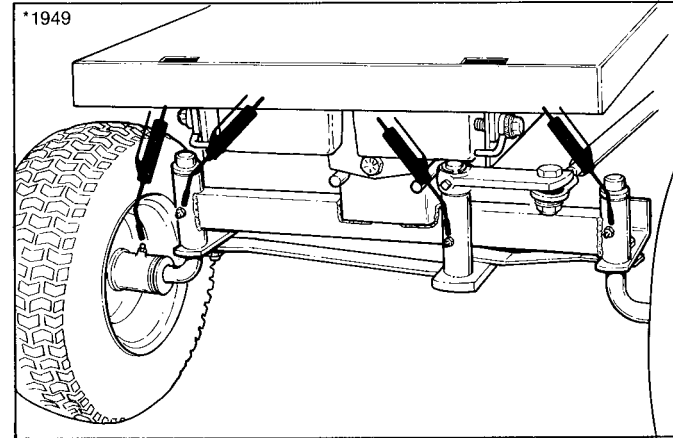

Figure 15. Lubricate Rear Axle and Spindles

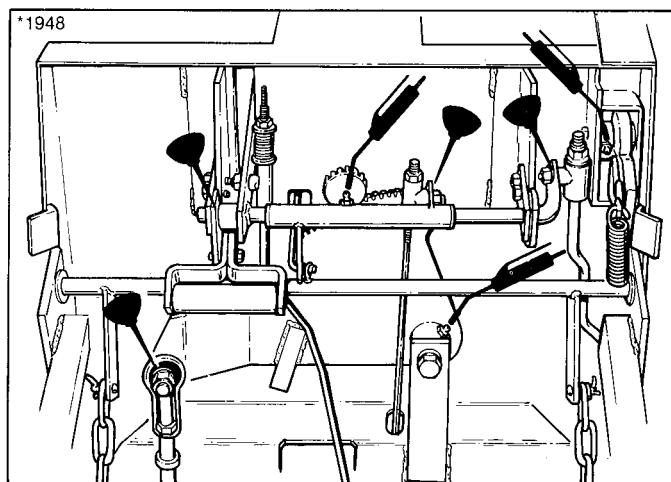

Figure 16. Lubricate Steering Gear and Brake/Clutch Rod Pivot Points (Hydro Model Shown)

Mower Lubrication

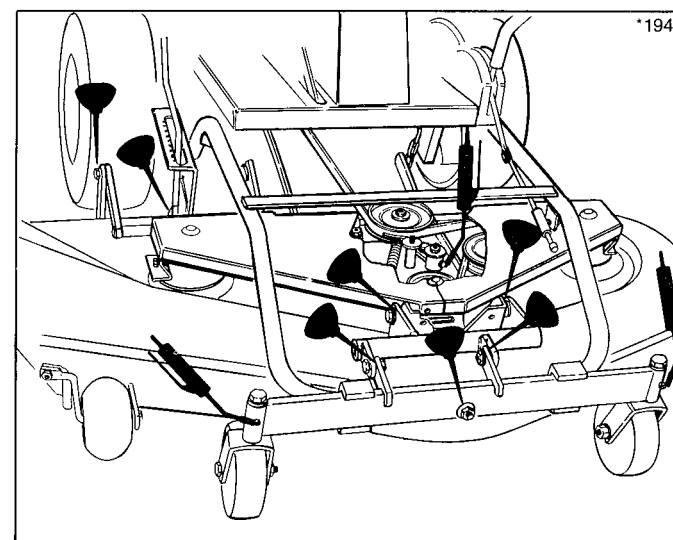

Figure 17. Lubricate Mower Pivot Points

(Cont'd.)

*1936

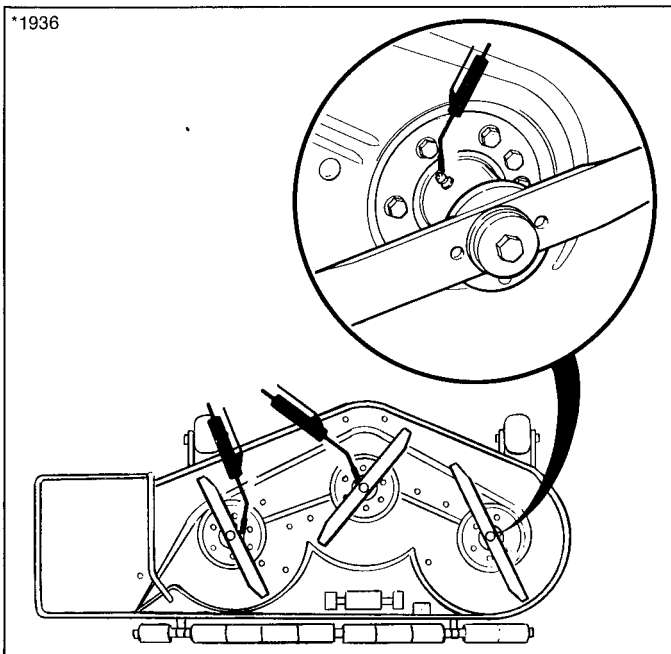

Figure 18. Arbor Grease Fittings

CHECK TIRE PRESSURE

Make sure the air pressure in the front tires is 8 to 12 psi (55 to 82 kPa) and the air pressure in the rear tires is 18 to 22 psi (123 to 150 kPa). Use a gauge with one-pound markings.

BATTERY MAINTENANCE

WARNING

For your personal safety when removing or installing battery cables, always disconnect the negative cable **FIRST** and reconnect it **LAST**. The positive battery terminal can easily be shorted to the tractor frame by a wrench or other tool if this is not done.

WARNING

Be careful when handling the battery. Avoid spilling electrolyte. Keep flames and sparks away from the battery.

Check Fluid Level

Check the battery fluid level. Wipe dirt from around the cap then remove the cap. The fluid must be even with the bottom of the split ring. If not, add distilled water. Reinstall the caps. Be sure the cover is in place over positive terminal. Make sure vent tube from battery cap extends beyond battery platform.

Cleaning Battery and Cables.

1. Lift rear platform to locate battery (figure 19). Disconnect the cables from the battery, negative cable first. A positive "+" sign is stamped on the battery next to the positive terminal.
2. Slip the battery straps off, disconnect the vent tube, and remove the battery.
3. Clean the battery terminals and cable clamps with a wire brush.
4. Scrub the battery, cable and battery compartment with baking soda and water.
5. Reinstall battery and straps. Reinstall vent tube so that it extends beyond battery compartment. The straps should be on each side of the cap.
6. Connect cables, positive cable first.
7. Coat cable clamps and terminals with petroleum jelly or approved terminal spray coating. Be sure to slide cover over positive terminal.

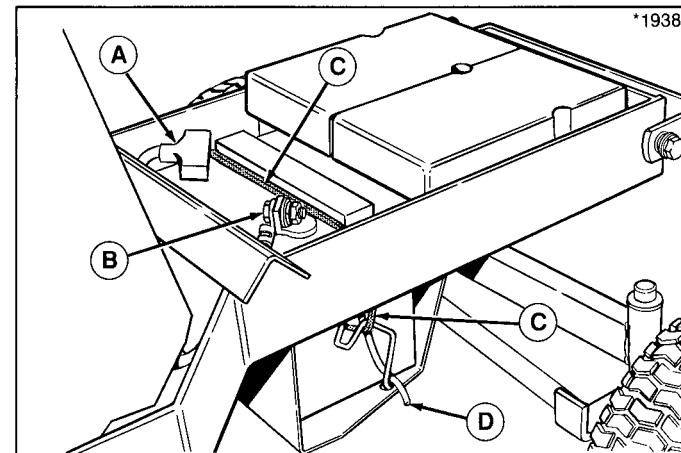

Figure 19. Battery
A. Positive Terminal
B. Negative Terminal
C. Strap
D. Vent Tube

CHECK TRANSMISSION FLUID LEVEL - Hydro Models

Allow rider to cool after operation. Fluid must be cool for an accurate check.

1. Raise the seat deck.
2. The fluid level is visible in the reservoir (figure 20) without removing cap. The level should be at FULL COLD mark. If not, go to step 3.
3. Clean the area around the reservoir (A, figure 20) and remove the reservoir cap. Add multipurpose hydraulic/transmission oil as required (see your dealer for recommendation). In extremely hot weather, 30W oil may be used for hydro pump. Do not mix multipurpose oil with 30W oil. Drain hydro system completely and refill with appropriate oil.

If reservoir is empty, clean area around vent plug (B, figure 20) and remove plug. Add oil through reservoir until fluid appears at vent plug opening. With clutch/brake pedal down, rotate fan or belt to remove trapped air. Reinstall vent plug. Fill reservoir to "Full Cold" mark. If the oil is black or milky, see your dealer to determine cause.

4. It will take a while for the oil to seep thru a filter screen into the reservoir. Check the level again after operating the rider a few times. If level is consistently low, see your dealer to check for leaks.
5. Keep cooling fins and fan cover free of grass and dirt accumulation.

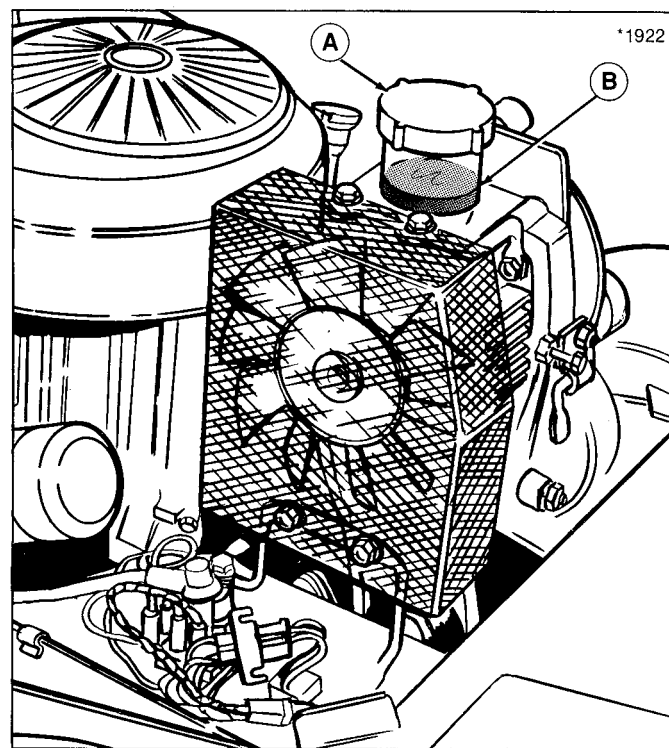

Figure 20. Hydrostatic Reservoir
A. Reservoir B. Vent Plug

MOWER REMOVAL & INSTALLATION

Removal

1. Mower can be easily removed and installed for lubrication, service and year-end storage.

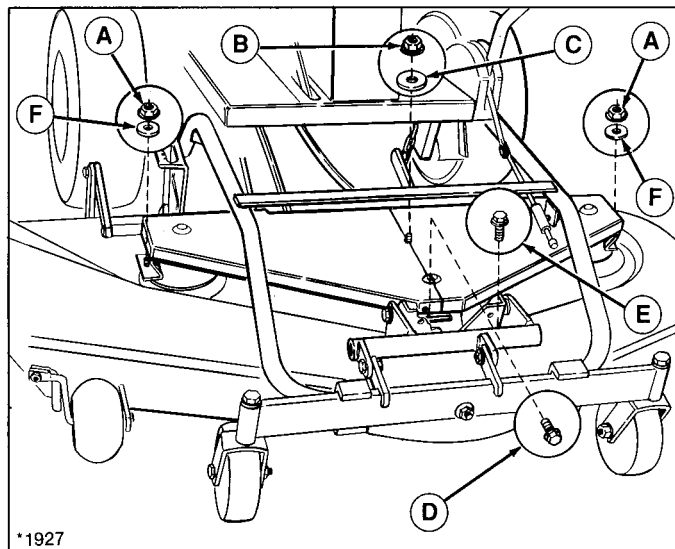

Figure 21. Belt Cover Removal

- A. Flange Whiz Nut, 1/2"
- B. Flange Whiz Nut, 9/16"
- C. Large Washer

- D. Taptite Screw, 3/8"
- E. Taptite Screw, 1/2"
- F. Flat Washer

2. Remove hardware securing belt covers to mower deck. Refer to figure 21. Remove belt covers (belt diagram is located on underside of belt cover).

WARNING

Use caution when moving spring-loaded idler pulley (A, figure 22). Spring tension is strong. Do not remove belt (B) from spring-loaded idler pulley (A). Remove belt from left and right idler pulleys (C & D).

3. Place mower in lowest cutting position. To provide slack, pull spring-loaded idler pulley away from belt and remove belt from around left hand and right hand idler pulley.
4. To remove chains from rider lift arms, remove cotter pin (I) and washer from weld stud (H). Replace washer and pin on weld stud.

(Cont'd.)

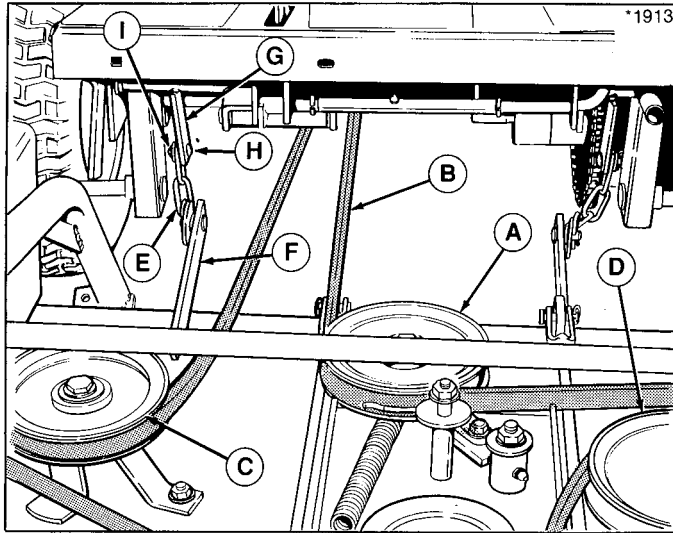

Figure 22. Removing Belt Tension

- A. Spring-Loaded Idler Pulley
- B. Belt
- C. Right Hand Idler Pulley
- D. Left Hand Idler Pulley
- E. Chain
- F. Mower Lift Arm
- G. Rider Lift Arm
- H. Weld Stud
- I. Cotter Pin

5. Remove the spring clips (A) and clevis pins (B) from mower hitch arms (C). Refer to figure 23. Drop mower hitch arms down. Remove large washer (D) from rider hitch arm. For storage, reinstall clevis pin (B) and spring clip (A) onto mower hitch arm with large washer in between hardware.

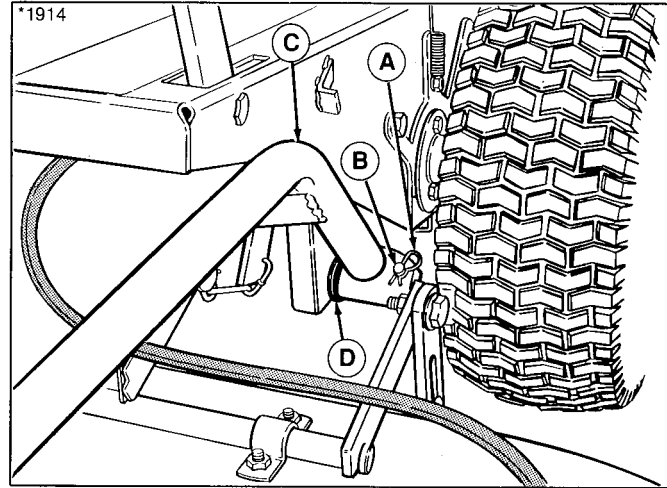

Figure 23. Hitch Arms

- A. Spring Clip
- B. Clevis Pin
- C. Mower Hitch Arm
- D. Washer

Normal Care

6. Disconnect the top and bottom halves of the mower lift arm as shown in figure 24. Reinstall spring clip (B) onto weld stud (A).

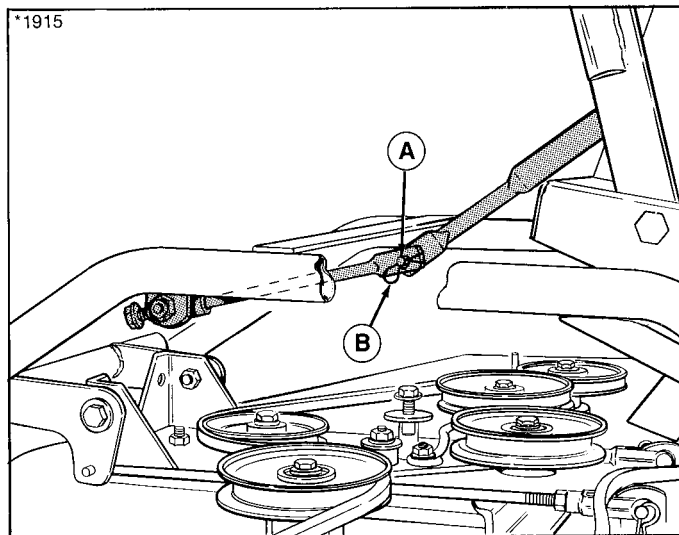

Figure 24. Lift Arm Halves

- A. Weld Stud**
B. Spring Clip.

7. To remove mower drive belt from electric clutch (PTO) pulley, the anti-spin rod (A) must be removed. Refer to figure 25.
- a. Remove spring clip from anti-spin rod outside rider frame.
 - b. Push rod through frame and disengage other end from electric clutch.

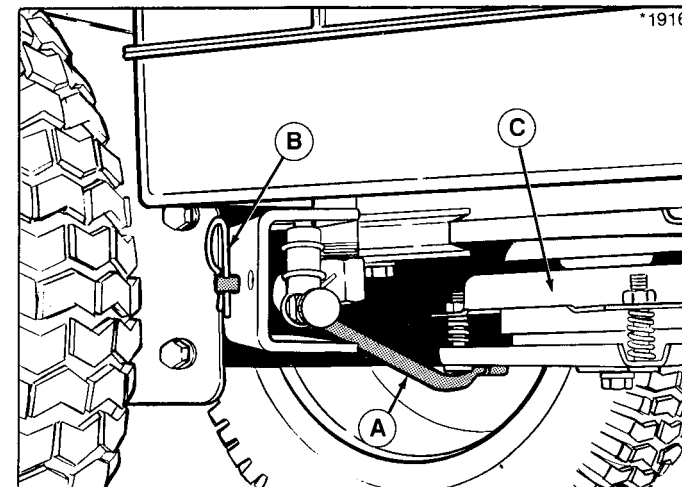

Figure 25. Anti-Spin Rod

- A. Anti-Spin Rod**
B. Spring Clip
C. Electric Clutch

8. Disconnect wire harness to electric clutch harness plug (A, figure 26). Remove ties (C) securing wire harness (A) to belt stop (B).

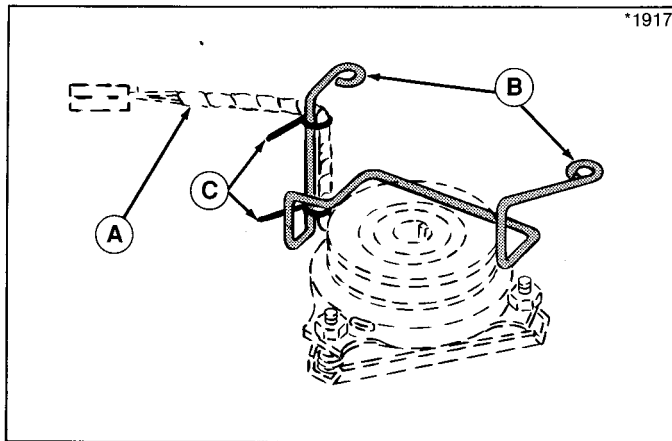

Figure 26. Electric Clutch Wire Harness

- A. Harness Plug
- B. Belt Stop
- C. Ties

9. Remove mower belt around bottom pulley (V-side) and around idler pulley (flat-side). Hardware securing belt stop may need to be loosened to remove belt. Belt diagram is shown in figure 27.

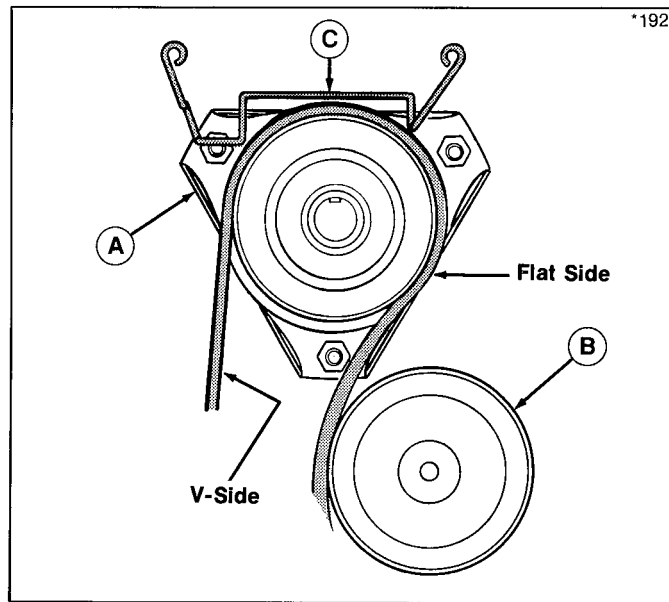

Figure 27. Belt Installation

- A. Electric Clutch
- B. Idler Pulley
- C. Belt Stop

10. Mower deck can now be rolled forward from underneath rider.

Installation

To install mower deck to rider, follow these steps. Refer to illustrations 21 - 27 on previous pages.

1. Position mower deck directly in front of rider.
2. Route belt underneath rider **over the drive axle**. Install mower belt around bottom pulley (V-side) of electric clutch. Refer to figure 27.
3. Connect wire harness for electric clutch. Refer to figure 26. Secure wire to belt stop with reusable ties. If ties are damaged, tape wire securely at top and bottom of belt stop.
4. **Anti-spin rod must be reinstalled for operation. Electric clutch will be immediately damaged if operated without anti-spin rod.** Refer to figure 25. Install rod to electric clutch. Insert other end through frame and secure with spring clip.
5. Connect top and bottom halves of mower lift arms. Refer to figure 24.
6. Install mower hitch arms to rider hitch arms. Refer to figure 23. Make sure large washer (E, figure 23) is placed on rider hitch arms. Secure with clevis pins and spring clips.
7. Connect chains (top link) to weld stud and secure with washers and cotter pins. Refer to figure 22.

8. Reinstall belt on right hand and left hand idler pulley by pulling on spring-loaded idler pulley. Read warning on page 27. Refer to figure 22.
9. Check mower belt routing carefully. Belt should be positioned as shown in figure 28.

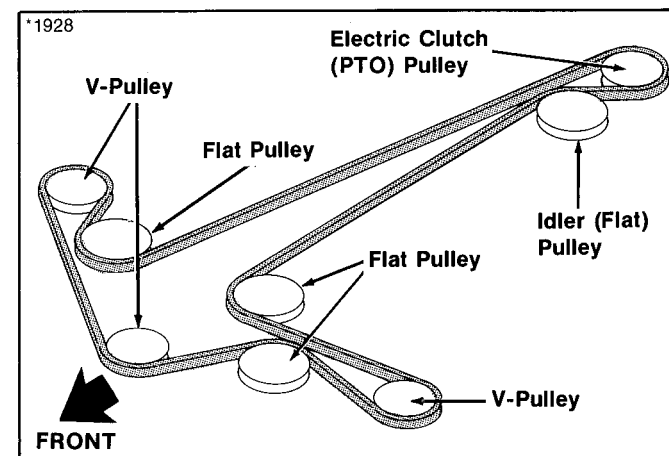

Figure 28. Mower Belt Routing

10. Make sure deflector is properly installed as shown in figure 29.

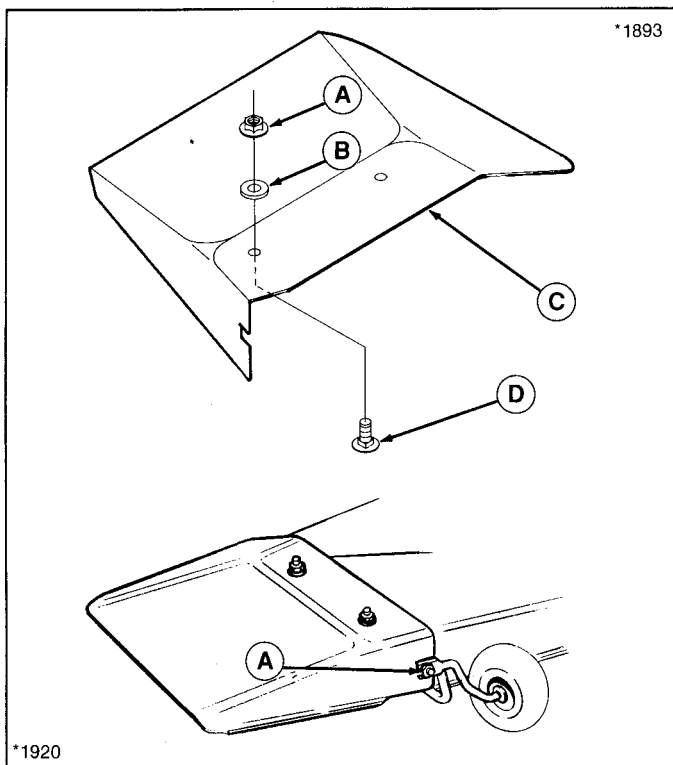

Figure 29. Deflector Installation

A. Whizlock Nut
B. Washer

C. Deflector
D. Carriage Bolt

SERVICING THE MOWER BLADES

WARNING

Do not handle the blade with bare hands. Do not touch the cutting edge.

Sharpening & Balancing

1. To remove a blade, wedge a wood block between blade and housing to prevent rotation. Then, turn capscrew counterclockwise to remove.
2. Use a file to sharpen blade to a fine edge. Remove all nicks and dents in blade edge. If blade is severely damaged it should be replaced.
3. To balance the blade, use a balancing machine or the following procedure. Drive a small nail into the side of a workbench or other vertical surface. Lubricate the nail with a drop of oil. Center the blade center hole on the nail. A balanced blade will remain level. File material off heavier end of blade until it is balanced.

Blade Installation

1. Reinstall the blade(s) with the tabs pointing upward. Install the spline washer, cup washer, and capscrew (see figure 30). Be sure the splines on the spline washer are engaged with the shaft splines. Be sure cup washer is installed with the concave side up.
2. To tighten the capscrew, wedge a wood block between blade and housing to prevent blade from turning. Torque the capscrew to 50 to 70 ft. lbs. (68-76 Nm).

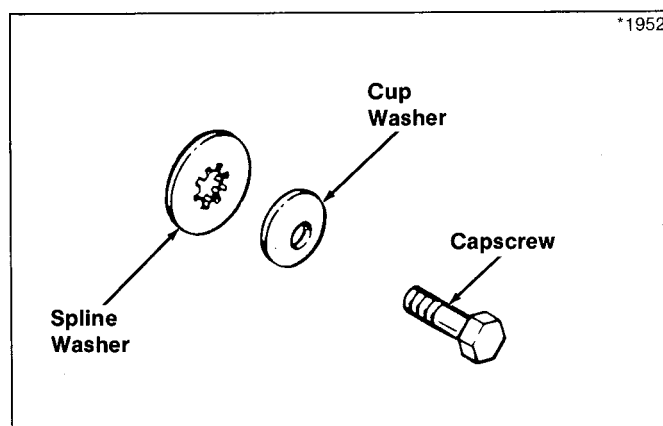

Figure 30. Blade Hardware

Troubleshooting

CONTENT OF SECTION

This section of the manual provides troubleshooting and repair instructions for the more common and easily corrected problems. For other problems, it is recommended that you contact your dealer.

WARNING

Perform maintenance on the rider or mower only when the engine is stopped and the parking brake engaged. Always remove the ignition key before beginning the maintenance to prevent accidental starting.

Problem	Cause/Remedy
1. Engine will not turnover or start.	<ul style="list-style-type: none"><li data-bbox="806 345 1402 399">A. Transmission lever not in neutral-start position. Shift into neutral.<li data-bbox="806 410 1528 431">B. Electric PTO switch in ON position. Place in OFF position.<li data-bbox="806 443 1650 496">C. Out of fuel. Allow engine to cool then refill the fuel tanks. Both tanks must be filled or the empty tank shut off at valve.<li data-bbox="806 508 1556 561">D. Engine flooded. Push choke knob in (16 HP) or move control out of CHOKE position (12 HP).<li data-bbox="806 573 1549 626">E. Circuit breaker tripped. Wait one minute for automatic reset. Replace if defective (see your dealer).<li data-bbox="806 638 1549 659">F. Battery terminals require cleaning. See Normal Care section.<li data-bbox="806 670 1423 691">G. Battery discharged or dead. Recharge or replace.<li data-bbox="806 703 1581 756">H. Wiring loose or broken. Visually check wiring & replace broken or frayed wires. Tighten loose connections.<li data-bbox="806 768 1436 789">I. Solenoid or starter motor faulty. Repair or replace.<li data-bbox="806 800 1602 821">J. Safety interlock switch faulty. Replace if needed (see your dealer.)<li data-bbox="806 833 1503 886">K. Spark plug(s) faulty, fouled or incorrectly gapped. Clean and gap or replace. See engine manual.<li data-bbox="806 898 1388 919">L. Water in fuel. Drain fuel & refill with fresh fuel.<li data-bbox="806 930 1423 951">M. Old stale gas. Drain fuel & replace with fresh fuel.

Troubleshooting

Problem	Cause/Remedy
2. Engine starts hard or runs poorly.	A. Fuel mixture too rich. Clean air filter. Check choke adjustment (engine speed control). See engine manual. B. Carburetor adjusted incorrectly. See engine manual. C. Spark plug(s) faulty, fouled, or incorrectly gapped. Clean and gap or replace. See engine manual.
3. Engine knocks.	A. Low oil level. Check/add oil as required. B. Using wrong grade oil. See engine manual
4. Excessive oil consumption.	A. Engine running too hot. Clean engine fins, blower screen and air cleaner. B. Using wrong weight oil. See engine manual. C. Too much oil in crankcase. Drain excessive oil.
5. Engine exhaust is black.	A. Dirty air filter. Clean air filter. See engine manual. B. Check engine speed control adjustment (choke). See engine manual.
6. Engine runs, but rider will not drive.	A. Transmission not in gear. Shift into gear. B. Hydro release valve engaged (hydro models). Disengage valve (see Operation section). C. Belt or chain is broken. Replace. Check chain adjustment. (See Adjustments section.) D. Drive belt slips. (See problem and cause below.)
7. Rider drive belt slips.	A. Clutch is out of adjustment. See your dealer. B. Pulleys or belt greasy or oily. Clean as required. C. Belt stretched or worn. Replace with correct belt. D. Clutch rod binding in guide. Oil clutch rod.

Troubleshooting

Problem	Cause/Remedy
8. Brake will not hold.	A. Brake is incorrectly adjusted. See your dealer. B. Brake band worn and requires replacement. See your dealer. C. Oil on brakes. Clean or replace brake band. See your dealer.
9. Rider steers hard.	A. Steering linkage is loose. Check and tighten any loose connections. B. Improper tire inflation. Check and correct. C. Spindle bearings dry. Grease spindles. See Normal Care - Lubrication section.
10. Rider drive belt does not stop when clutch-brake depressed.	A. Belt stops out of adjustment. See Adjustment section. B. Clutch out of adjustment. See your dealer.

TROUBLESHOOTING (MOWER)

1. Mower will not raise.	A. Lift arms or lift chains not properly attached or damaged. Attach or repair.
2. Mower cut is uneven.	A. Mower not leveled properly. See Mower Leveling.
3. Mower cut is rough looking.	A. Engine speed too slow. Set for three-fourths to full speed. B. Ground speed too fast. Use transmission lever to control ground speed. C. Blades dull and require sharpening. See Normal Care section. D. Mower drive belt slipping. Belt oily or worn. Clean or replace belt as necessary. E. Check PTO Clutch Adjustment. Clutch may need to be burnished. F. Blades not properly fastened to arbors. See Normal Care section.

Troubleshooting

Problem	Cause/Remedy
4. Engine stalls easily with mower engaged.	A. Ground speed too fast. Use lower gear. B. Carburetor not adjusted properly. C. Cutting height set too low when mowing tall grass. Cut tall grass at maximum cutting height during first pass. D. Discharge chute jamming with cut grass. Cut grass with discharge pointing toward previously cut area.
5. Excessive mower vibration.	A. Mower blades, arbors, or pulleys are bent. Check and replace as necessary. B. Mower blades are out of balance. Remove, sharpen and balance blades (see Normal Care section).
6. Excessive belt breakage.	A. Belt tension too tight. Readjust belt tension. See your dealer. B. Bent or rough pulleys. Repair or replace. C. Using incorrect belt. See your dealer.
7. Mower drive belt slips or fails to drive.	A. Mower drive belt out of adjustment. See your dealer. B. Belt stops out of adjustment. Check. C. Mower drive belt broken. Replace.

BATTERY REPLACEMENT

A battery too weak to start the engine may not need to be replaced. It may, as an example, mean that the charging system is not working properly or that the battery has lost its charge during storage. First check the fluid level and clean the battery. Have the battery recharged if necessary. If there is any doubt about the cause of the problem, see your dealer. If you must replace the battery, remove and install the battery as described in "Clean Battery and Cables."

JUMP STARTING WITH AUXILIARY (BOOSTER) BATTERY

Jump starting is not recommended. First check the battery in "Battery Replacement" above. If jump starting must be done, follow these directions. Both booster and discharged batteries should be treated carefully when using jumper cable. Follow exactly the procedure outlined below, being careful not to cause sparks. Refer to figure 31.

WARNING

Never expose battery to open flame or electric spark — battery action generates hydrogen gas which is flammable and explosive. Do not allow battery acid to contact skin, eyes, fabrics, or painted surfaces. Batteries contain a sulfuric acid solution which can cause serious personal injury or property damage.

WARNING

Any procedure other than the above could result in: (1) personal injury caused by electrolyte squirting out of the battery vents, (2) personal injury or property damage due to the battery explosion, (3) damage to the charging system of the booster vehicle or the other immobilized vehicle.

Do not attempt to jump start a vehicle having a frozen battery because the battery may rupture or explode. If a frozen battery is suspected, examine all fill vents of the battery. If ice can be seen, do not attempt to start with jumper cables.

NOTE

The positive terminal has a cover. Slide cover away to perform this procedure. Slide cover back over positive terminal for normal operation.

1. Set parking brake and place transmission in "NEUTRAL".
2. Remove vent cap from both the booster and the discharged batteries. Lay a cloth over the open vent wells on each battery. These two actions help reduce the explosion hazard always present in either battery when connecting a "live" battery to a "dead" battery.

Troubleshooting

3. Attach one end on one jumper cable to the positive terminal of the booster battery (identified by a red color, "+" or "P" on the battery case, post or clamp) and the other end of same cable to positive terminal of discharged battery.
4. Attach one end of the remaining cable to the negative terminal (black color, "-" or "N") of the discharged battery, and the other end to a bare metal surface on the frame of your rider AWAY FROM the battery compartment (do not connect directly to negative post

of booster battery). Take care that clamps from one cable do not inadvertently touch the clamps on the other cable. Do not lean over the battery when making the connection.

5. The rider with discharged battery should now start.

Reverse the jump starting procedure exactly to remove the jumper cables. Then reinstall the vent caps and throw the cloths away as they may have corrosive acid on them.

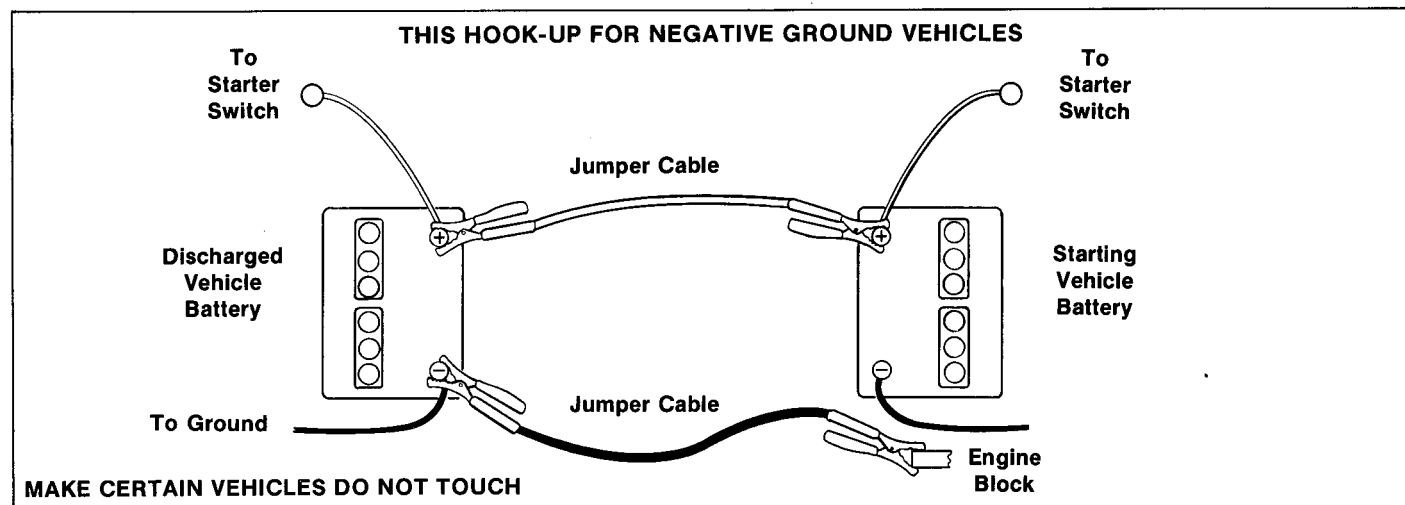

Figure 31. Jump Starting

MOWER BELT REPLACEMENT

1. Park the rider on a level surface.
2. Belt can be replaced with mower deck removed or installed to rider. Follow these steps to replace belt with mower deck installed or refer first to steps and illustrations provided under "Mower Removal & Installation".
 - a. Remove belt covers. Refer to figure 21.

⚠ WARNING

Use caution when moving spring-loaded idler pulley (A, figure 22). Spring tension is strong. Do not remove belt (B) from spring-loaded idler pulley. Remove belt from left and right idler pulleys (C and D).

- b. Remove belt from idler pulleys by pulling spring loaded idler pulley to gain slack in belt. Refer to figure 22.
- c. Remove ties securing electric clutch wire harness to belt stop and disconnect harness. Refer to figure 26.
- d. Remove anti-spin rod from frame and electric clutch. Refer to figure 25.
- e. Remove belt from electric clutch pulley. Refer to figure 27. Hardware securing belt stops may need to be loosened to remove belt.

- f. Remove belt from mower deck and replace with new belt.
- g. Check belt pattern as shown in figure 32. Make sure mower belt goes underneath rider **over the drive axle..**

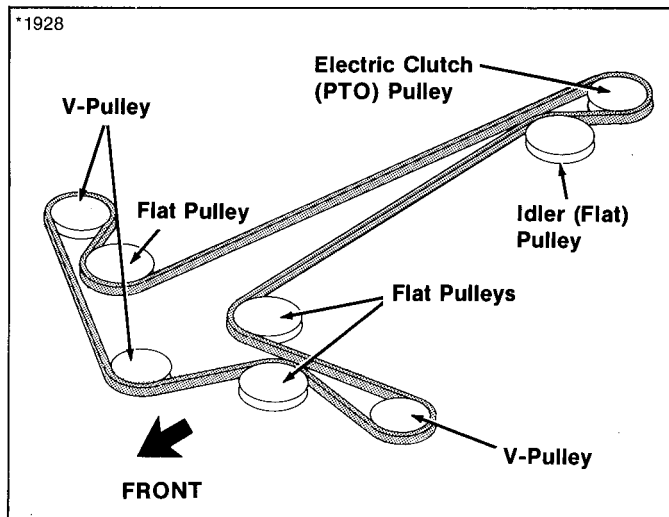

Figure 32. Mower Belt Pattern

3. Reverse above steps to reinstall removed parts. **Anti-spin rod must be reinstalled before operation or electric clutch will be damaged immediately.** Refer to figure 25.
4. Make sure belt covers and deflectors are properly secured before operating mower. Refer to figure 29.

POWER UNIT BELTS

"V" Belt Replacement - Hydro Models

1. Set the parking brake to provide slack in the belt.
2. Remove the screen (A, figure 33) by removing four screws (B; two at top and two at bottom).
3. Remove the fan (C) by removing one screw (D) in center. Keep washers (E) in order for correct reassembly.
4. Slip the belt (F) from the transmission pulley.

(Cont'd.)

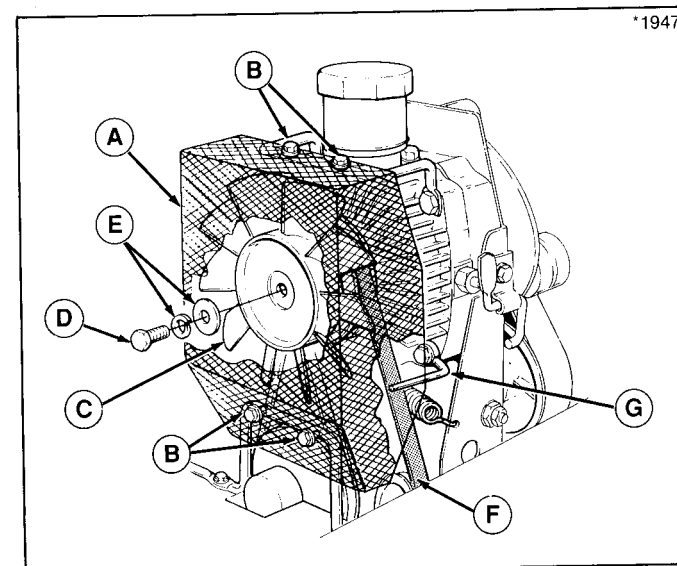

Figure 33. Hydro Pump

- A. Screen
- B. Capscrews
- C. Fan
- D. Capscrews
- E. Washers
- F. Belt
- G. Belt Stop

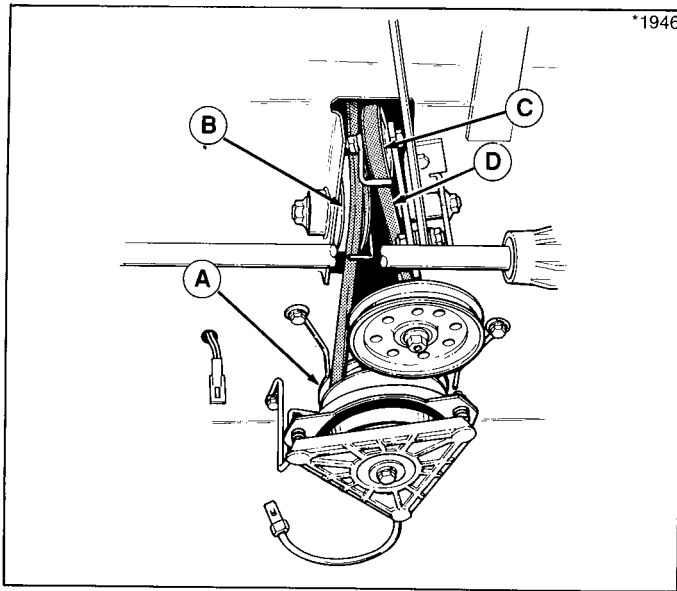

Figure 34. "V" Belt

- A. Engine Pulley
- B. Fixed Pulley
- C. Idler Pulley
- D. Belt

5. Remove belt (D, figure 34) from idler pulley (C), fixed pulley (B) and engine pulley (A). Loosen belt stops as necessary.
6. Remove mower belt from electric clutch pulley by following steps outlined in "Mower Belt Replacement".

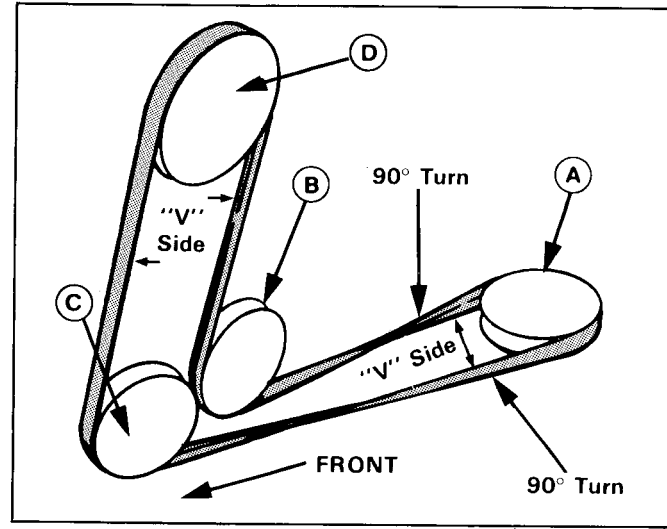

Figure 35. Belt Pattern (Seen From Left-Hand Side)

- A. Engine Pulley
- B. Fixed Pulley
- C. Idler Pulley
- D. Transmission Pulley

7. Place the new belt onto the engine pulley (A, figure 35), fixed pulley (B) and idler pulley (C). Note that "V" side of belt rides in the pulleys, and flat side rides against fixed pulley (B). The belt turns 90° between engine pulley and the fixed pulley (B) and between engine pulley and idler pulley (C).

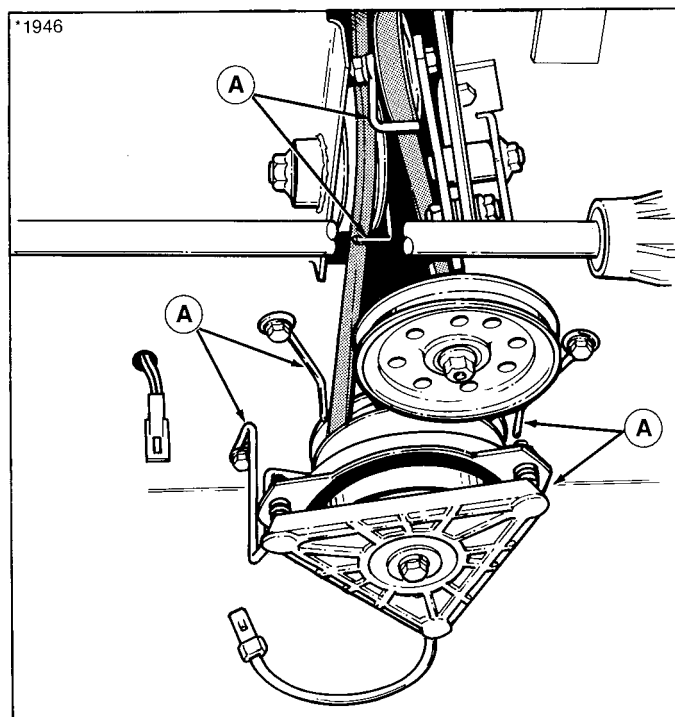

Figure 36. Belt Stop Locations
A. Belt Stops

8. Pull belt up from top and place onto the transmission pulley (D, figure 35).
9. Reinstall mower belt to electric clutch pulley. Follow steps under "Mower Belt Replacement" to reinstall electric clutch wiring harness and anti-spin rod.
10. Note that a tab on inner side of fan (C, figure 33) fits into a hole when fan is installed. Install fan with original hardware.
11. Install screen (A, figure 33) with two screws at top and two screws at bottom.
12. Release parking brake to check belt stop adjustment. There should be 1/16 to 1/8 inch clearance between belt and belt stops. Five belt stops are shown in figure 36. Also check belt stop (A, figure 37) at transmission pulley. To adjust, loosen mounting hardware, position belt stop, and then tighten hardware.
13. Perform Clutch/Brake Adjustment as described in Adjustments section.

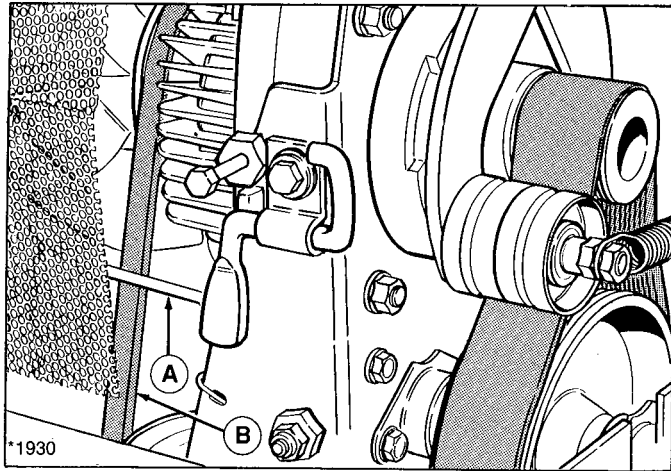

Figure 37. Belt Stop Location

A. Belt Stop

B. "V" Belt

"V" Belt Replacement - Gear Models

1. To provide slack in the belt, set the parking brake.
2. Remove the mower belt from electric clutch pulley by following steps outlined in "Mower Belt Replacement".
3. Slip the belt off the pulleys (figure 38), loosening the belt guides as necessary.
4. Install the new belt as shown in figure 38, making sure there are no twists in the belt.
5. Release the parking brake to provide belt tension. Then position the belt guides 1/16 to 1/8 inch from belt and tighten.
6. Reinstall mower belt to electric clutch pulley as described in "Mower Belt Replacement".
7. Perform "Clutch-Brake Adjustment" as described in Adjustment section.

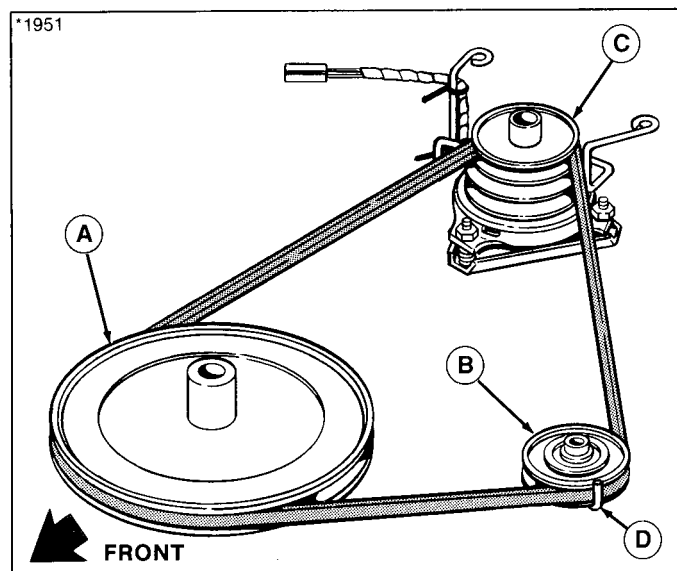

Figure 38. Belt Pattern - Gear Drive

- A. Transmission Pulley
- B. Idler Pulley
- C. Engine Pulley
- D. Belt Stop

Adjustments

SEAT ADJUSTMENT

1. Unlatch seat by pushing down on back of seat and unhooking latch bar (A, figure 39). Make sure latch bar locks in place after lowering seat.
2. The seat can be moved forward or back for operator comfort. Loosen the four screws (B) and move the seat to the desired position. Tighten the screws.
3. Make sure there is enough slack in wire (D) for seat to be adjusted fore/aft and raised and lowered.
4. The springs (C) can be moved to forward holes for lighter operator. Pull up out of holes to relocate springs.

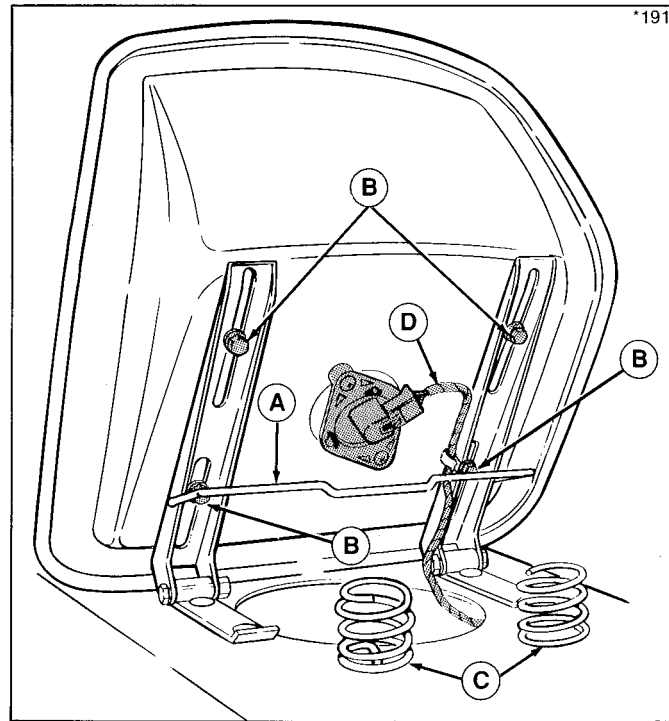

Figure 39. Seat Adjustment

- A. Latch Bar
- B. Capscrews
- C. Springs
- D. Wire Harness

NEUTRAL ADJUSTMENT - Hydro Models



WARNING
Keep away from moving parts when engine is running.

1. Adjustment can be performed with mower installed.
2. Loosen nuts (B, figure 40) on either side of guide (C). Leave 1/4" clearance on each side.

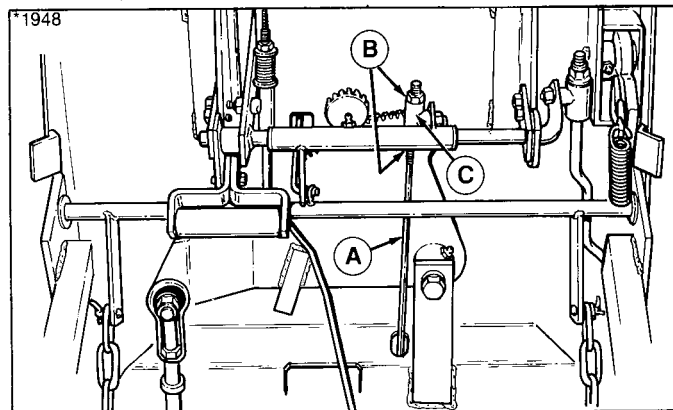

Figure 40. Hydro Control Rod

- A. Hydro Control Rod
- B. Nuts
- C. Guide

3. Loosen the two capscrews (A, figure 41).
4. Raise front tires off the ground by placing jack stands under each side of frame. Do not support rider at axle as axle will rotate during adjustment.

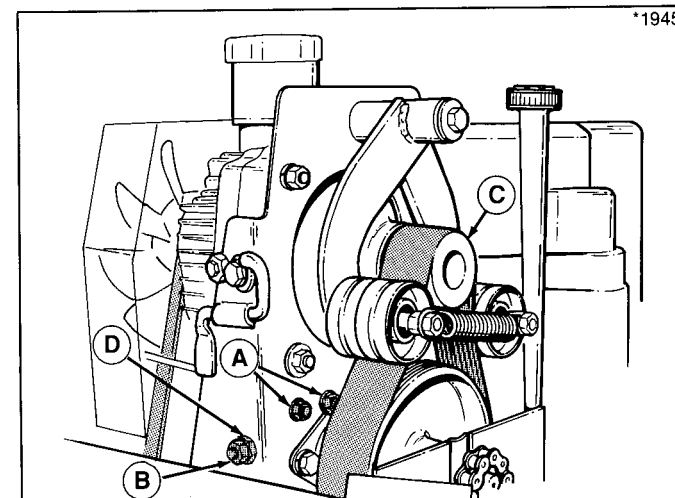

Figure 41. Neutral Adjustment

- A. Capscrews
- B. Jam Nut
- C. Pulley
- D. Adjustment Nut

Adjustments

5. Start the engine and raise the seat deck. For an accurate neutral adjustment, keep engine RPM level high during adjustment.
6. Loosen the jam nut (B). Turn the inner nut (D) either left or right until the output pulley (C) stops turning.
7. Tighten the two capscrews (A).
8. Tighten the jam nut (B) against inner nut (D).
9. Shut off the engine.
10. Make sure transmission control lever is in neutral.
11. Tighten the two nuts (B, figure 40) against the guide. Make sure rod guide does not move when tightening nuts.
12. The rider can be taken off the jackstands.

CLUTCH/BRAKE ADJUSTMENT - Hydro Models

1. Release parking brake.
2. The clutch rod spring (A, figure 42) should measure 1-3/16" to 1-5/16" along the long side (between insides of washers). To adjust, tighten or loosen the nut (B).
3. Pull the brake rod (C) toward front as far as possible. Tighten or loosen the nut (D) to achieve a gap of 3/8 inch between rear surface of nut and the guide that rod extends through.

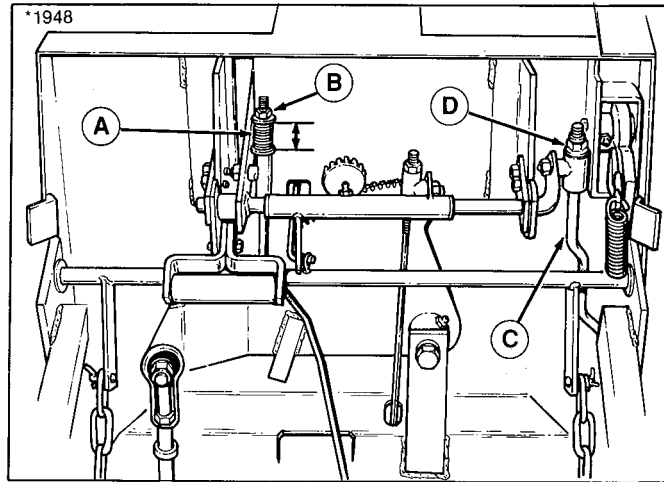

Figure 42. Hydro Models

- | | |
|--------------------|-------------------|
| A. Clutch Spring | C. Brake Rod |
| B. Nut, Clutch Rod | D. Nut, Brake Rod |

CLUTCH/BRAKE ADJUSTMENT - Gear Models

1. Release parking brake.
2. The clutch rod spring (A, figure 43) should measure 2" to 2-1/8" along the long side (between insides of washers). To adjust, tighten or loosen the nut (B).
3. Pull the brake rod (C) toward front as far as possible. Tighten or loosen the nut (D) to achieve a gap of 3/8 inch between rear surface of nut and the guide that rod extends through.

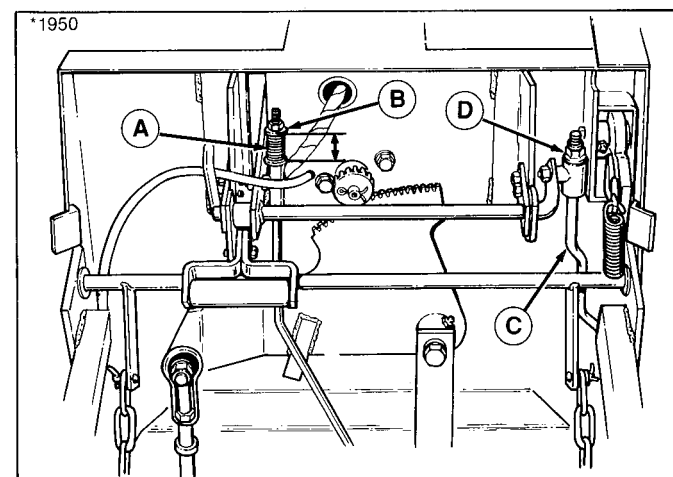

Figure 43. Gear Models

- A. Clutch Spring**
- B. Nut, Clutch Rod**
- C. Brake Rod**
- D. Nut, Brake Rod**

Adjustments

CHAIN ADJUSTMENT - Gear Models

On gear drive models, the chain can be adjusted to remove excess slack.

1. Remove the cover (B, figure 44) by removing two screws (A).
2. Loosen the locknut (C) which holds the spacer (D) in slot.
3. Move the spacer toward the chain to tighten, then tighten the capscrew and nut. Do not adjust chain so it is tight; only remove excess slack.

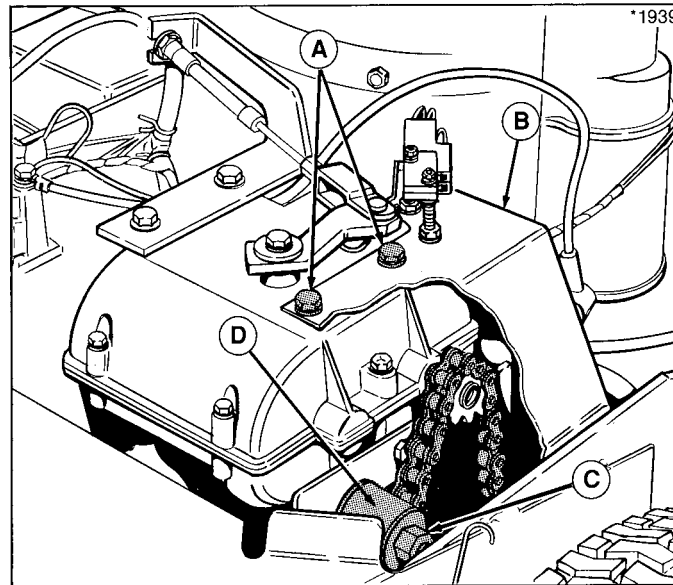

Figure 44. Chain Adjustment

- A. Screws
- B. Cover
- C. Locknut
- D. Spacer

PTO CLUTCH ADJUSTMENT**Burnishing the Clutch**

Before the PTO clutch is used for the first time, it should be burnished as follows. Also, if mower cut is rough looking, the clutch may require burnishing or adjustment. To burnish, the mower must be installed.

1. Start the engine and set at full throttle.
2. Turn the PTO switch to ON position, leave on for 15 seconds, then turn off.
3. Do this ten times to burnish the clutch.

Clutch Adjustment

1. Use a 0.010 to 0.012 feeler gauge to check the electric clutch at three places (A, figure 45). Insert the gauge. There should be a slight resistance as gauge is moved in and out of slot. If tight, or loose, go to step 2.
2. Loosen or tighten one of the nut (B) to adjust one of the three places. Loosen nut to increase gap; tighten to decrease gap.
3. After adjusting a nut, check the other two with feeler gauge. Adjustment at one location will change adjustment at other two locations. Make sure all three locations have proper adjustment.

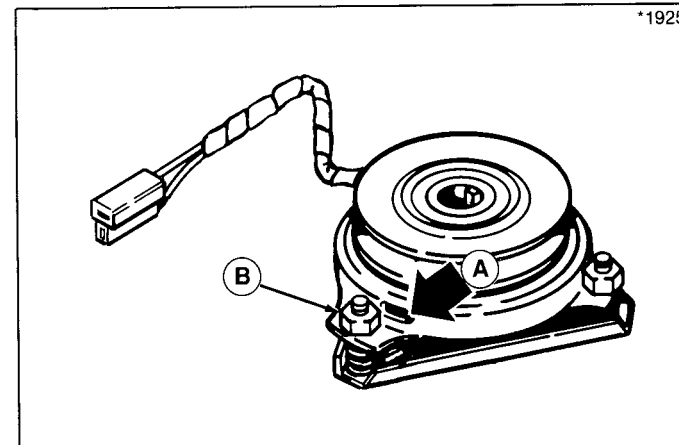

Figure 45. PTO Clutch Adjustment

A. Slot

B. Adjustment Nut

Adjustments

MOWER LEVELING

WARNING

During leveling check, remove ignition key, then remove spark plug(s) wire(s) and fasten it away from the spark plug(s).

Side-To-Side

1. Park the rider on a level surface.
2. Place mower in high cut position.
3. Turn the blades side-to-side and measure distance from outside tips of blades to ground. Measurement should be equal. For adjustment, refer to figure 46.
 - a. Loosen the capscrew (A) on the right hand side of mower roller bracket (B).
 - b. Raise or lower right hand side of mower as necessary. Retighten capscrew.
 - c. Recheck side-to-side measurement.

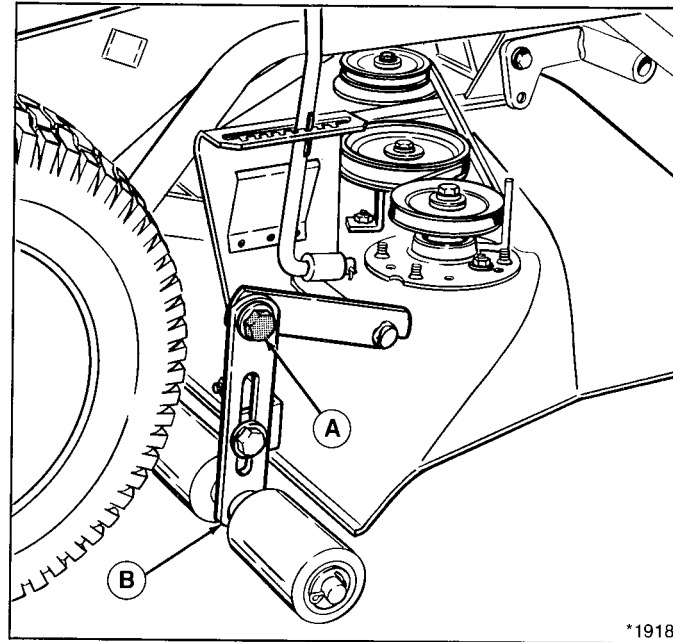

Figure 46. Side-to-Side Leveling

A. Capscrew

B. Roller Bracket

Front-To-Back

4. Turn the blades front-to-back. Measure the distance from the ground to the front tip of the center blade, and from the ground to rear tips of left-hand and right-hand blades. Measurement should be equal. For adjustment, refer to figure 47.
 - a. Remove belt covers as shown in figure 21.
 - b. Remove the spring clip (A) and clevis pin (B) from both adjustment rods (E).
 - c. Loosen jamnut (D) in front of clevis (C).
 - d. Turn clevises an equal number of turns. (Turn clevis towards front to raise front of mower).
 - e. Reinstall clevis to mower rollers with clevis pin and spring clip. Recheck front-to-back measurements.
 - f. If adjustment is correct, tighten jamnuts snug against clevises.
 - g. Reinstall belt covers (refer to figure 21) and deflector, if removed (refer to figure 29).

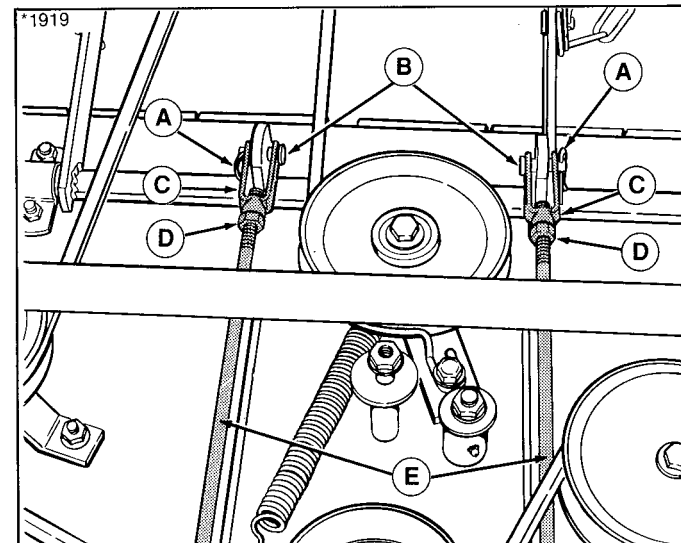

Figure 47. Front-to-Back Leveling

- A. Spring Clip
- B. Clevis Pin
- C. Clevis
- D. Jamnut
- E. Adjustment Rod

Specifications

ENGINE: 12.5HP & 16HP

Make Briggs & Stratton
Model Vanguard™ V-Twin
Horsepower 12.5/16 HP @ 3600 RPM
Cycles 4
Cylinders 2
Bore 2.68 in. (68 mm)
Stroke 2.60 in. (66 mm)
Displacement 29.3 Cu. In. (480 cc)
Construction Overhead Valve, Cast Iron Sleeves, Aluminum Crankcase
Electrical System 12 Volt, 16 Amp Alternator Regulated. Battery: 12 Volt, 200 Cold Cranking Amps, 23 Min. Reserve Capacity
Ignition Magnetron Electronic Ignition
Air Cleaner Ducted Paper Cartridge and Foam Precleaner, large 325 sq. in. Air Filtering System
Lubrication Full Pressure Lube with Oil Filter
Oil Capacity 3.5 Pints with Filter (1.6 L)
Fuel Tank Cap. 2 Gals. Total - 2 Tanks
Muffler Quiet Compact, Low Back Pressure

ENGINE: 12 HP

Make Briggs & Stratton
Model Industrial/Commercial
Horsepower 12 HP @ 3600 RPM
Cycles 4
Cylinders 1
Bore 3.44 In. (8.7 cm)
Stroke 3.06 in. (7.8 cm)
Displacement 28.4 Cu. In. (465 cc)
Electrical System 12 Volt, 9 Amp Alternator Regulated. Battery: 12 Volt, 200 Cold Cranking Amps, 23 min. Reserve Capacity
Ignition Electronic; Solid State, Maintenance Free
Air Cleaner Reusable Oil Foam Element
Oil Capacity 2.25 Pints (1.1 L)
Fuel Tank Cap. 2 Gals. Total - 2 Tanks
Alternator 9 Amp, DC Alternator
Muffler Super Lo-Tone

Specifications

TRANSMISSION:	Gear	Hydro
Type	5 Speed w/Inline Shift	Infinitely Variable
Final Drive	#40 Chain	#40 Chain
Differential	Bevel Gear Type	Bevel Gear Type
Speeds	1.3 - 4.5 MPH Fwd. 0 - 1.5 MPH Rev.	0 - 5.0 MPH Fwd. 0 - 2.6 MPH Rev.

CHASSIS:

Frame	1/4" Steel Rails, 12 Gauge Eng. Base
Front Axle	3/4" Axle Shaft w/ Differential
Rear Axle	1" x 1-1/2" Solid Steel Bar
Body	All Steel, Precision Welds (125" Min.)
Seat Deck	16 Gauge-Hinged for Easy Access
Seat Adjustment	3" Front to Back, Spring Mounted
Front Wheels:	
Tread	Turf Pattern
Size	16 x 6.5-8
Inflation Press.	8-12 psi
Rear Wheels:	
Tread	Turf Pattern
Size	13 x 5.0-6
Inflation Press.	18 to 22 psi
Turning Radius	
Inside Front Wheel	6 In. (15.2 cm)

DIMENSIONS:

Height at:	
steering wheel	40.5 In. (102.9 cm)
steering column	31.75 In. (80.6 cm)
seat back	37.25 In. (94.6 cm)
engine cover	26.5 In. (67.3 cm)
Length:	
Overall	87.25 In. (221.6 cm)
Tractor	64.25 In. (163.2 cm)
Width:	
of Body	20.5 In. (52.1 cm)
at Front Wheels	38 In. (96.5 cm)
at Rear Wheels	30 In. (76.2 cm)
Overall	57.5 In. (146.1 cm) - 42" Mower 63.5 In. (161.3 cm) - 48" Mower
Wheel Base	40 In. (101.6 cm)
Weight (approx.):	
Net	12 HP Gear: 607 lbs. (275 kg) 12 HP Hydro: 622 lbs. (282 kg) 12.5/16 HP Hydro: 633 lbs. (286.75 kg)

MOWER:

Effective Cutting Width	42" Mower - 42 In. (107 cm) 48" Mower - 48 In. (122 cm)
Overall Width with Deflector	42" Mower - 57.5 In. (146.1 cm) 48" Mower - 63.5 In. (161.3 cm)
Weight	42" Mower - 147 lbs. (66.59 kg) 48" Mower - 156 lbs. (70.67 kg)
Variable Cutting Ht.	1-1/4 to 4 In. (3.2 to 10.2 mm)
Blade Arrangement	Three Staggered Blades
Mower Drive	V-Belt from Tractor PTO Pulley
Spindle Bearings	Lubricated and Sealed Ball Bearings

Common Replacement Parts

Listed below are part numbers for the more common replacement parts. Only genuine Deutz-Allis replacement parts will assure optimum performance and safety. Do not attempt repairs or maintenance unless proper procedures and safety precautions are followed. For assistance in any area, see your dealer.

REPLACEMENT PARTS

QTY. PER UNIT	DESCRIPTION	PART NUMBER
3	Blade, 48" Mower	1656146
3	Blade, 42" Mower	1656147
2	Washer, Mower Lift Chain	1919326
2	Cotter Pin, Mower Lift Chain	1918447
1	Belt, 42" Mower	1703371
1	Belt, 48" Mower	1703372

QTY. PER UNIT	DESCRIPTION	PART NUMBER
2	Straight Pin, Mower Hitch Arms	174215
2	Spring Clip, Mower Hitch Arms	1918196
1	"V" Belt, Engine (Hydro)	1704735
1	"V" Belt, Engine (Gear)	1678354
1	Belt, Intermediate (Flat, Hydro)	1700362
1	Keys (2 Keys w/Ring)	122203
2	Interlock Switch, PTO & Trans.	1704113
1	Interlock Switch, Seat	1703373
1	Battery	1685215
1	Solenoid	1685290
1	Switch, Electric Clutch	1675800
1	Switch, Oil Pressure (On Engine)	1703956
1	Headlamp	1679954

Optional Attachments and Accessories

See your dealer to purchase these items.

- Turbo Grass Collector
- Turbo Quad Bagger™
- Dump Cart
- Turbo Twin-Bag Collector
- Woodside Transporter
- Dethatcher
- Horn
- Hubcaps

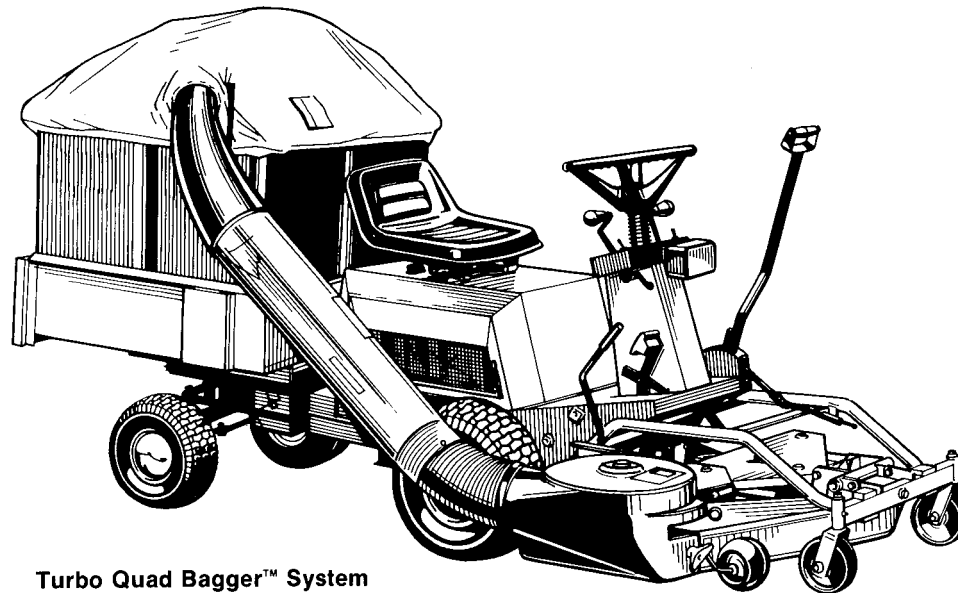

Turbo Quad Bagger™ System

Turbo Grass Collection System - Collect grass clippings, thatch, and leaves with powerful mower-driven vacuum collector. Can be used with Quad Bagger™ and Dump Cart or Twin-Bag Collector.

Parts Manual Available

Deutz-Allis Lawn & Garden Equipment Parts Manuals are fully illustrated. All of the assemblies are shown in exploded views which show the relationship of the parts and how they go together. Important assembly notes and special torque values are included in the illustrations. For standard hardware, a torque specification chart is included.

To order, enclose this form with a check or money order made out to DEUTZ-ALLIS LAWN & GARDEN EQUIPMENT. Address the envelope to:

Deutz-Allis Lawn & Garden Equipment
Attn: Cashier
500 N. Spring Street
P.O. Box 997
Port Washington, WI 530740997

**Extend Equipment Life -
Use Only Genuine Deutz-Allis
Lawn & Garden Equipment
Repair Parts**

- I would like a Parts Manual (TP-1172) for my 1300 Series Hydrostatic Riding Mower. Enclosed is a check or money order for \$5.50.
- I would like a Parts Manual (TP-1171) for my 1300 Series Gear Riding Mower. Enclosed is check or money order for \$5.50.
- I would like a Parts Manual (TP-1173) for my 1300 Series Riding Mower Attachments and Accessories. Enclosed is check or money order for \$5.50.
- I would like a Service Manual (79011962) for my 1300 Series Riding Mower Attachments and Accessories. Enclosed is check or money order for \$8.00.
- Please include \$1.50 for shipping and handling.

Rider Mfg. No. 169 _____

Mower Mfg. No. 169 _____

Print clearly. This will be your mailing label.
Allow four to six weeks for delivery.

Name _____

Street or RFD _____

City, State, Zip _____

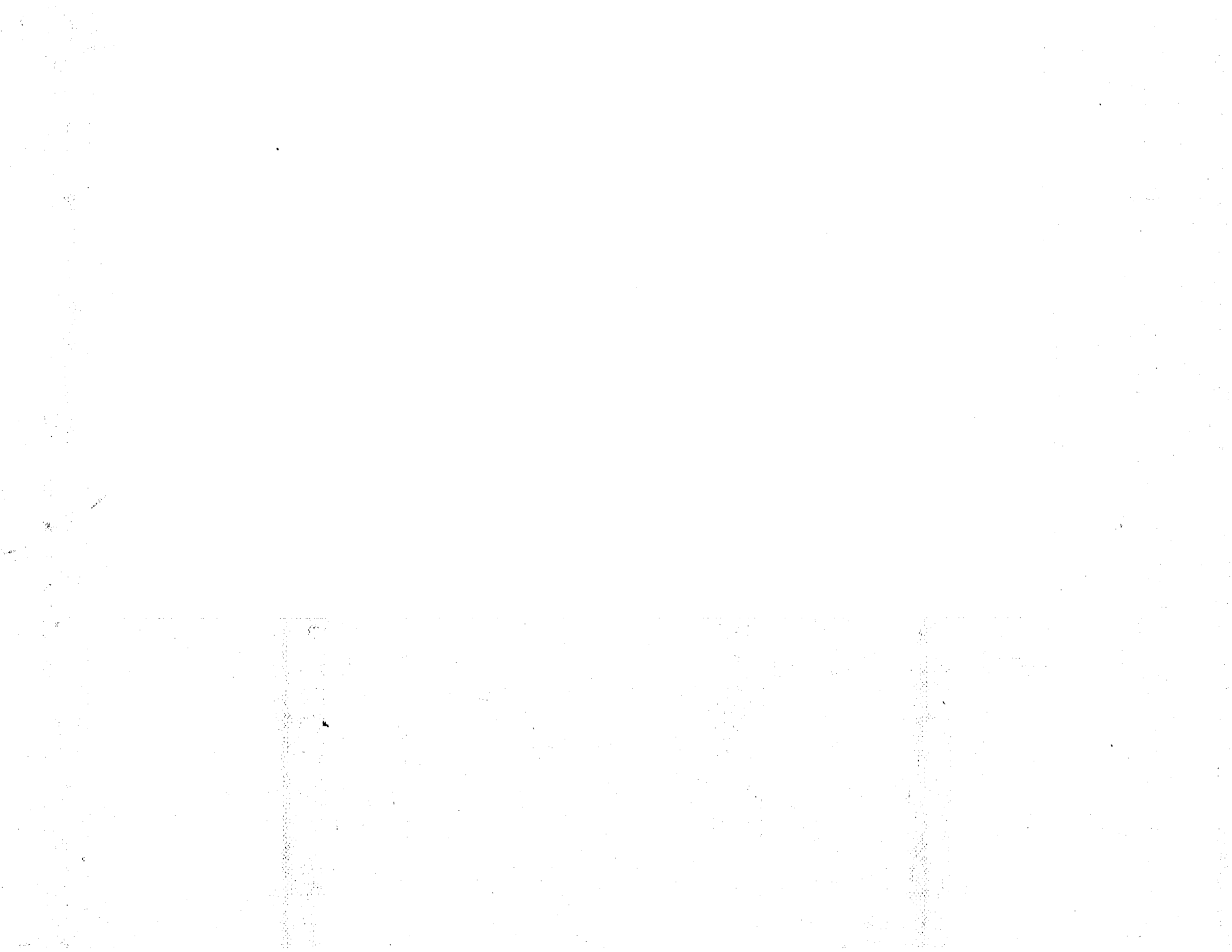

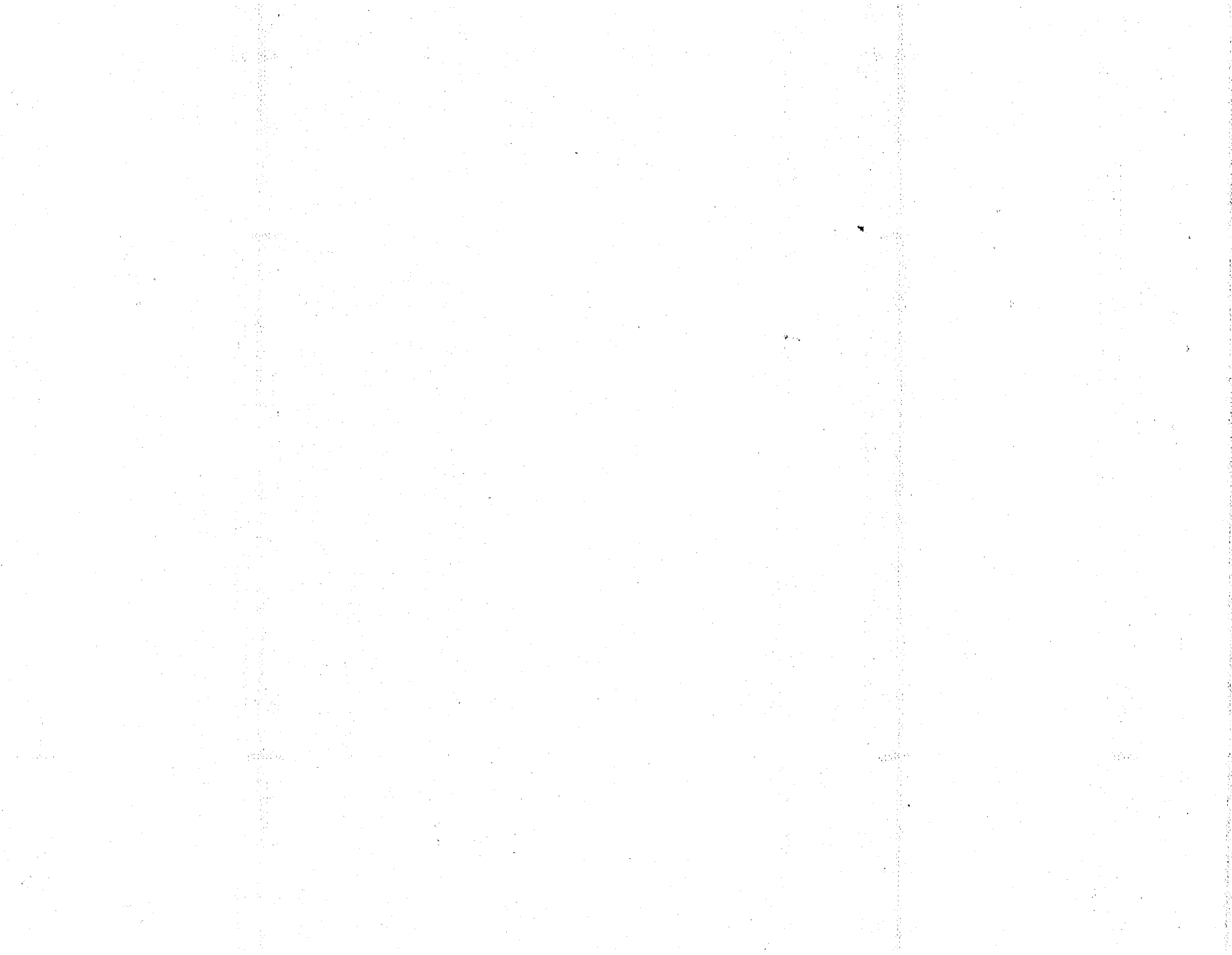



AGCO

**DEUTZ
ALLIS®**

LAWN & GARDEN EQUIPMENT

500 N. Spring St., P.O. Box 997 Port Washington, WI USA 53074-0997

FORM 1707275-02
PRINTED IN U.S.A.
©1992 5/92