

Operator's Manual

Series 4200

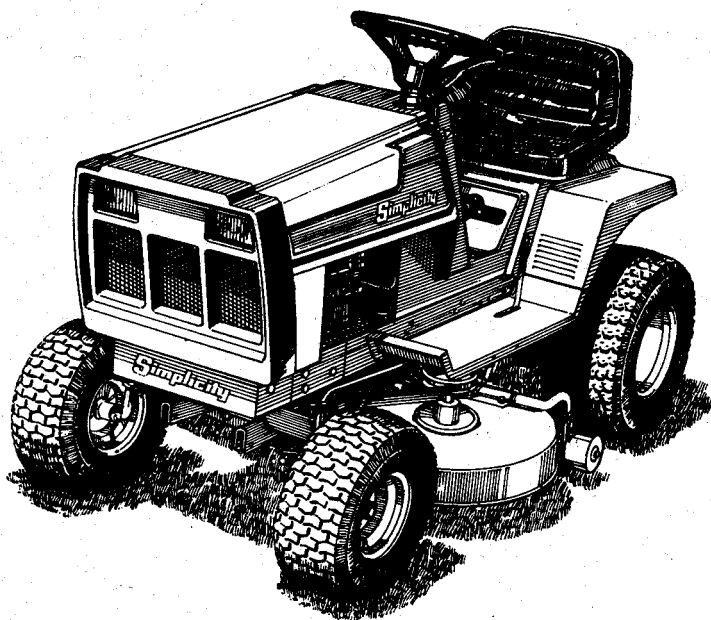

8 HP TRACTOR
MFG. NO. 1690456
11 HP TRACTOR
MFG. NO. 1690458
36" MOWER
MFG. NO. 1690274

Simplicity

Contents

SAFETY RULES	2	TRROUBLESHOOTING & REPAIR	16
DECALS	4	CONTENT OF SECTION	16
MOWER INSTALLATION & REMOVAL	5	TROUBLESHOOTING PROCEDURES	16
OPERATION	7	BATTERY REPLACEMENT	18
CONTROLS	7	JUMP STARTING	18
STARTING THE ENGINE	8	TRACTOR DRIVE BELT REPLACEMENT	20
SELECTING GEARS & ENGINE SPEED	8	MOWER BELT REPLACEMENT	21
STARTING & STOPPING	8	ADJUSTMENTS	22
BEFORE LEAVING OPERATOR'S POSITION	9	TRACTOR ADJUSTMENTS (Later Models)	22
MOWING PATTERN & TIPS	9	TRACTOR ADJUSTMENTS (Earlier Models)	23
NORMAL CARE	10	MOWER ADJUSTMENTS	24
DETERMINING OPERATION TIME		MOWER DRIVE BELT TENSION	24
NORMAL CARE SCHEDULE		RIGHT-ARBOR BELT STOP	24
RAISING HOOD & SEAT DECK/		IDLER PULLEY BELT GUIDE	25
ADJUSTING SEAT	10	PTO PULLEY BELT STOPS	25
CHECKING/ADDING GASOLINE	11	LEVELLING THE MOWER	26
LUBRICATING THE TRACTOR	11	SPECIFICATIONS	27
CHECKING THE FUEL FILTER	11	ATTACHMENTS & ACCESSORIES	28
CHECKING BATTERY FLUID	12	COMMON REPLACEMENT PARTS	29
CLEANING THE BATTERY & CABLES	12	PARTS MANUAL AVAILABLE	31
CHECKING TIRE PRESSURES	12		
TRACTOR NORMAL STORAGE	12		
TRACTOR OFF-SEASON STORAGE	13		
STARTING AFTER STORAGE	13		
LUBRICATING THE MOWER	14		
SHARPENING & BALANCING THE BLADES	14		
MOWER OFF-SEASON STORAGE	15		

NOTE

In this manual, "left" and "right" are referred to as seen from operating position.

Safety Rules

Read these safety rules and follow them closely. Failure to obey these rules could result in loss of control of vehicle, severe personal injury to yourself or bystanders, or damage to property or equipment. The triangle in the text signifies important cautions or warnings which must be followed.

- Disengage all attachment clutches and shift into neutral before attempting to start the engine.

- Wear heavy footwear. Do not operate tractor when barefoot or when wearing open sandals or canvas shoes.

GENERAL

- Read the Operator's Manual carefully. Be thoroughly familiar with the controls and the proper use of the equipment.
- Never allow children to operate the machine. Do not allow adults to operate it without proper instruction.
- Do not carry passengers.
- Use only attachments or accessories designed for your machine. See your dealer for a complete list of recommended attachments or accessories.
- Keep the area of operation clear of all persons, particularly small children, and pets.
- Never direct discharge of material toward bystanders.
- Make sure:
 - a. tractor and attachments are in good operating condition,

- b. all safety devices and shields are in place and in good working condition, and

- c. all adjustments are correct.

PREPARATION

- Handle gasoline with care - it is highly flammable.
 - a. Use approved gasoline container.
 - b. Never remove the fuel tank cap or add gasoline to a running or hot engine, or fill the fuel tank indoors. Wipe up spilled gasoline.
- Do not run the engine indoors. Exhaust fumes are deadly.
- Clear the work area of objects which might be picked up and thrown by attachments.

OPERATION

- Engage the parking brake, disengage the PTO, lower the attachment, stop the engine and remove the key before leaving the operator's position for any reason, such as to unclog attachment chutes or to make repairs or adjustments.
- Stop tractor and attachments and inspect for damage after striking a foreign object. Repair any damage before restarting and operating the equipment.
- Watch out for traffic when crossing or operating near roadways.
- Operate only in daylight or in good artificial light.
- Never make any adjustment while the engine is running.

Safety Rules

- Operate only up and down the face of slopes; never across the face. Do not stop or start suddenly on slopes.
- Reduce speed on slopes and in sharp turns to prevent tipping or loss of control. Use extreme caution when changing direction on slopes.
- Be especially careful not to touch tractor or attachment parts which might be hot from operation. Allow such parts to cool before attempting to maintain, adjust, or service.
- Stay alert for holes in the terrain and other hidden hazards. Be extra careful when operating on wet, slippery surfaces.
- If equipment begins to vibrate abnormally, disengage power to attachments and stop engine at once. Inspect for damage and correct before starting up tractor.
- Use care when pulling loads or using heavy equipment.
 - a. Use only drawbar hitch point.
 - b. Limit loads to those you can safely control.
 - c. Do not turn sharply. Use care when backing.
 - d. Use weights when recommended in the tractor or attachment Operator's Manual.
- Disengage power to attachments(s) when transporting or not in use.

MAINTENANCE & STORAGE

- Keep all nuts, bolts, and screws tight to be sure the equipment is in safe working condition.
- Do not change the engine governor settings or overspeed the engine.
- To reduce fire hazard, keep the engine free of grass, leaves, and excess grease.
- Never store the equipment with gasoline in the tank inside a building where fumes may reach an open flame or spark. Allow the engine to cool before storing in any enclosure.

Decals

ALL WARNING, CAUTION, and instructional messages on your tractor and mower should be carefully read and obeyed. Personal bodily injury can result when these instructions are not followed. The information is for your safety and it is important. The safety messages on this page are on your tractor and mower.

DANGER

1. Stand clear of discharge opening.
2. Do not operate mower without discharge deflector or entire grass collector system properly installed.

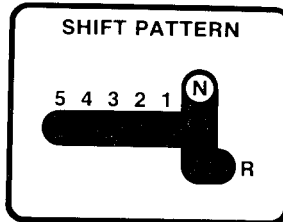
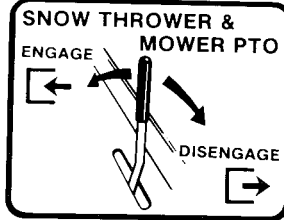

Safety Instructions

- Keep all shields in place.
 - Keep hands, feet and clothing away from power driven parts.
 - Keep people and pets a safe distance away from machine.
 - For your safety, transmission shift lever must be in neutral, PTO disengaged and parking brake set before starting.
 - Before operating read safety and operating instructions in operator's manual.
- Before leaving operator's position:
- Set parking brake. Do not rely on transmission to hold tractor.
 - Disengage PTO clutch.
 - Shut off engine and remove key.
 - Shift transmission into a forward gear.
 - Wait for all movement to stop before servicing.

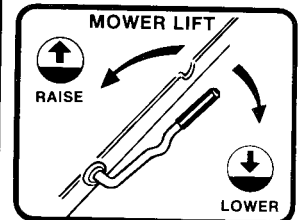
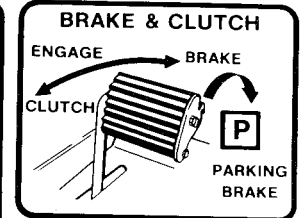

DANGER

keep hands & feet
from under mower

Mower Installation & Removal



WARNING

Engage the parking brake, disengage the PTO, stop the engine and remove the key before attempting to install or remove the mower.

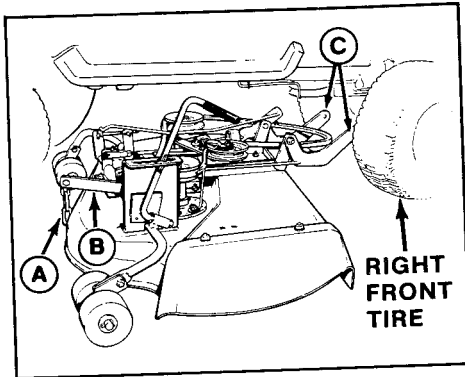

- A. Lift Chain
- B. Lift Arm
- C. Hitch Arms

Figure 1. Installing 36" Mower

NOTE

The lift chain (A, figure 1) should be connected to the rear hole in the mower lift arm (B) when mounting on 4200 Series tractors.

1. Place your tractor and mower on a hard level surface, such as concrete, with the mower on the right side of the tractor.
2. Turn the front wheels of the tractor as far as they go to the left.
3. Place the mower in the lowest cutting

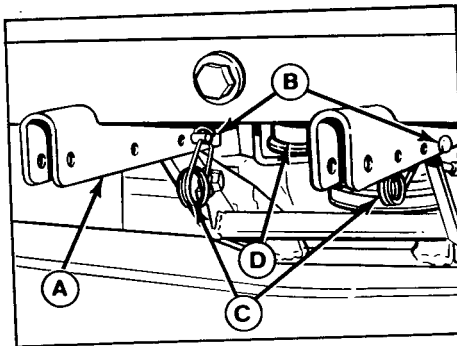

- A. Hitch
- B. Pins
- C. Safety Clips
- D. Drive Belt

Figure 2. Mower Hitch Attached

position and slide it under the tractor (see figure 1). Align arms (C, figure 1) in tractor hitch (A, figure 2).

4. Insert the lift link (B, figure 3) into the hole in the lift arm (A) from left side then pivot back and down. Slip the chain (C) onto the lift link (B).
5. Attach the mower hitch to the rear holes in the tractor hitch (figure 2), using the two pins and safety clips provided (C).

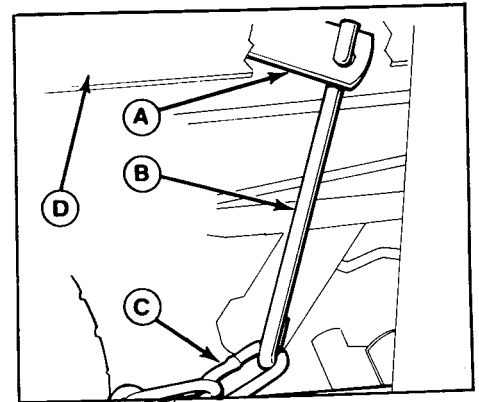

- A. Lift Arm
- B. Lift Link
- C. Lift Chain
- D. Tractor Frame

Figure 3. Installing Lift Link

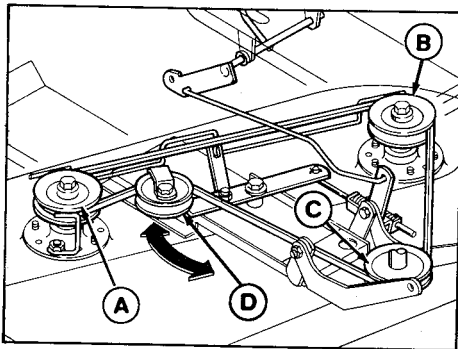

- A. V-Pulley, Right Arbor
- B. V-Pulley, Left Arbor
- C. Engine PTO Pulley
- D. Flat Idler Pulley

Figure 4. Mower Belt Pattern - 36"

6. Slip the mower drive belt onto the PTO pulley. Loosen belt stops as necessary. The left-hand belt stop is item A in figure 5. The right-hand belt stop is item A in figure 6.
7. Make sure the belt is properly installed on the mower pulleys. The belt pattern is shown in figure 4.
8. Insert one end of the PTO rod (B, figure 7) in the mower PTO arm (A) and the

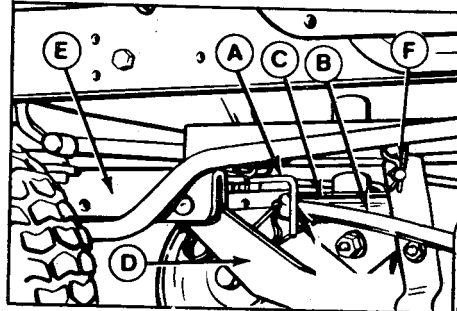

- A. Belt Stop
- B. Belt
- C. PTO Pulley
- D. Mower Hitch Arm
- E. Tractor Hitch
- F. Spring Clip

Figure 5. Left-Hand Belt Stop

other end in the tractor PTO arm (C) in hole marked "MOW". The rod must be inserted into the holes from the right-hand side as shown. Refer to figure 7 to make sure you connected correct end of rod to front. Install the spring clips (D).

9. If installing mower for the first time, or if a new belt was installed, perform the mower adjustments in the Adjustments section.

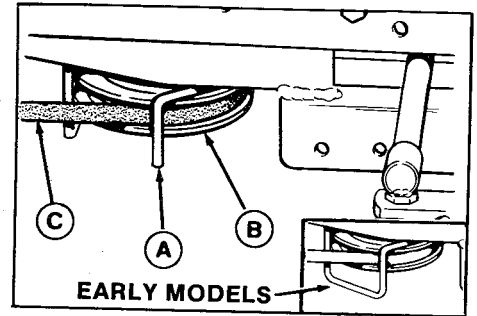

- A. Belt Stop
- B. PTO Pulley
- C. Belt

Figure 6. Right-Hand Belt Stop

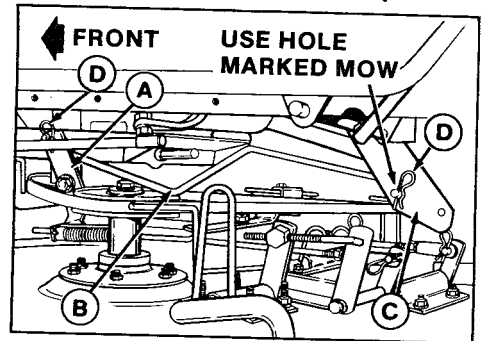

- A. Mower PTO Arm
- B. PTO Rod
- C. Tractor PTO Arm
- D. Spring Clip

Figure 7. Installing PTO Rod

10. Reverse the procedure to remove the mower.

Operation

CONTROLS

Refer to figure 8 for an explanation of tractor and mower controls.

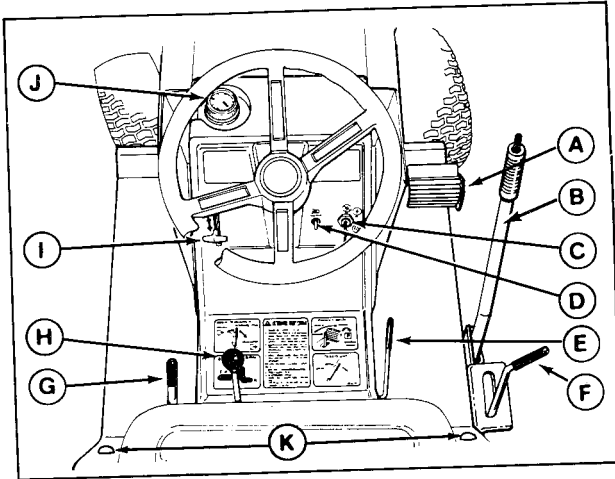

Figure 8. Tractor & Mower Controls

ITEM	NAME	FUNCTION
A	Clutch-Brake	Disengages tractor clutch when pressed down at least halfway. Applies brake when fully depressed. Engages parking brake when latched over footrest.
B	Lift Lever	Lifts and holds attachments in transport position (only required with attachment other than mower). (Optional)
C	Ignition Switch	Operates with key to start, run, or stop engine.
D	Light Switch	Switches headlights on or off (optional).
E	Lift Lever	Lifts and holds mower in transport position.
F	Mower Height Control Lever	Adjusts mower cutting height.
G	PTO (Power Take Off) Lever	Engages and disengages power to attachment. Pull back to disengage.
H	Gear Shift Lever	Shifts transmission gears to control ground speed. Five speeds forward, one speed reverse.
I	Engine Speed Control	Position from SLOW to FAST to control engine speed. Also position for engine CHOKE.
J	Gas Gauge/ Cap	Shows amount of gasoline in the tank and serves as tank cap.
K	Seat Deck Latch	Press button on each side to tilt the seat deck back.

STARTING THE ENGINE

1. Set the parking brake.
2. Set engine speed control to **CHOKE**. A warm engine may not require choking.
3. Lift PTO lever as far as it will go to the rear to disengage the attachment.
4. Set gear shift lever in **NEUTRAL**.
5. Insert the key into the ignition switch and turn it to **START**. When engine starts, release the key.
6. Move the engine speed control to **SLOW**. Warm up the engine by running it for at least a minute before engaging the PTO lever or driving the tractor.

SELECTING GEARS & ENGINE SPEED

Most mowing is done in third or fourth gear with engine speed between 3/4 and full speed. If the terrain is rough, hilly, or sloping use first or second gear. If the grass is wet or over three inches (76 mm) high, use full engine speed (with low gear) so the mower will have enough power to cut the grass. Shift gears only with tractor stopped and clutch-brake pedal fully depressed.

**WARNING****Slope Operation**

Never operate on slopes greater than 30 percent (16.7°) which is a rise of three feet vertically in 10 feet horizontally. When operating on slopes that are greater than 15 percent (8.5°) but less than 30 percent use rear wheel weights (see your dealer). Select slow ground speed before driving onto slope. Mow UP and DOWN the slope, never across the face, use caution when changing directions and DO NOT START OR STOP.

STARTING & STOPPING

1. Refer to Normal Care Chart and perform any needed care.
2. Clear the work area of any objects which may be caught in or thrown by mower.
3. Position the front wheels straight ahead. If possible, the first motion should be straight forward or backward.
4. Start the engine.
5. Set engine control for 1/3 to 1/2 speed. Select the gear best suited for conditions.
6. Release the parking brake by unlatching clutch-brake pedal from the foot rest.
7. Make sure the path in desired direction of movement is clear.
8. If you are ready to mow, engage the mower PTO with moderately fast motion. Engaging PTO too slowly may cause belt wear.
9. **Slowly** release the clutch-brake pedal to engage clutch and start tractor into motion.
10. Adjust engine speed control to desired speed. Between 3/4 and full speed is recommended for mowing.
11. For a gradual stop, press the pedal down only far enough to disengage the clutch. For a more rapid stop, press pedal down farther to apply the brake. See "Before Leaving Operator's Position" (next page).

BEFORE LEAVING OPERATOR'S POSITION

1. Stop tractor motion, and engage the parking brake.
2. Disengage the PTO and lower the attachment.
3. Set engine speed control to SLOW. Stopping a hot engine too fast may cause engine damage. Let engine idle for about a minute.
4. Turn key to OFF and remove it.
5. Place gear shift lever into gear.



WARNING

Before leaving the operator's position for any reason, engage the parking brake, disengage the PTO, stop the engine and remove the key.



WARNING

To reduce fire hazard, keep the engine, tractor and mower free of grass, leaves and excess grease.

MOWING PATTERN & TIPS

For the first use of the mower choose a smooth level area. Cut long straight strips overlapping slightly.

The size and type of area to be mowed determine the best mowing pattern to use. Obstructions such as trees, fences and buildings must also be considered. Where possible, make one or two passes in a clockwise direction around the outside of the area to keep cut grass off fences and walks. The remainder of the mowing should be done in a counterclockwise direction so the clippings are dispersed on the cut area.

Where possible, keep the left side of the mower toward trees, posts, or other obstacles on the first pass around the obstacles to keep hand trimming to a minimum.

On moderate size, frequently mowed lawns where grass is light and dry, it is sometimes practical to mow in a clockwise direction so that clippings are thrown toward the center of the lawn and concentrated for pickup and removal.

Most lawns should be mowed to keep the grass approximately two to three inches (50 to 76 mm) high. Best results are obtained by cutting often and not too short. To help keep a green lawn, never mow more than one third off the height of the grass, or a maximum of one inch (25 mm), in one mowing. For extremely tall grass, set the cutting height at maximum for the first pass, and then reset to the desired height and mow again.

On thick, or springy grass or soft ground, the mower rollers may sink into the ground giving too low a cut. Adjust the cutting height as necessary. For best appearance, grass should be cut in the afternoon or early evening (in daylight) when it is free of external moisture.

Where possible, change patterns occasionally to eliminate matting, graining or a corrugated appearance.

Normal Care

DETERMINING OPERATING TIME

Determining operating time is easily accomplished if the tractor is equipped with an optional hourmeter. If not, multiply the time it takes to do one job by the number of times you've done the job.

NORMAL CARE SCHEDULE

A schedule for normal care is provided in Table 1.

RAISING HOOD & SEAT DECK

To raise the hood, grasp both sides of the hood near the dash and pull outward. There are two styles of seat latches. If there is a button on each side of the front of the seat deck, near the foot rests, press in both buttons and tilt the seat deck back. (On other models, lift the latch under left side of seat deck and tilt seat deck back).

ADJUSTING THE SEAT

Raise the seat deck. While holding the seat, loosen the four capscrews that secure seat to seat deck. Position the seat as desired then tighten the capscrews.

Car Required	See	Schedule					
		Before First Use	Before Each Use	Every 5-Hours	** Every 25 Hours	Every 100 Hours	*** Spring and Fall
Check gas gauge	P. 11	•	•				
Check tractor & mower for loose nuts, screws, bolts, oil leaks, etc.		•	•	•			
Check engine oil level	Engine Manual	•	•	•			
Clean engine & air filter	Engine Manual				•		
Change engine oil*	Engine Manual				•		•
Lubricate tractor & mower	P. 11,14	•			•		
Check battery fluid	P.12	•			•		
Clean battery & cables	P.12						•
Clean/sharpen blades	P.14						•
Inspect spark plug(s)	Engine Manual						•
Check fuel filter	P.11						•
Check tire pressures	P.12	•			•		

*Change original engine oil after first 5 hours of operation.
 **More often in hot (over 85°F; 30°C) weather or dusty operating conditions.
 ***Only if tractor is used in both summer (over 40°F) and winter (under 40°F; 4.5°C)

Table 1. Schedule of Normal Care - Tractor & Mower.

CHECKING/ADDING GASOLINE

Check the gas gauge/cap to be sure there is enough gasoline to complete the job. To add gasoline, remove the gas gauge/cap. Refer to your engine manual for gasoline recommendations. Install and hand tighten the gas gauge/cap.

LUBRICATING THE TRACTOR

Lubricate the tractor as shown in figures 9 thru 12. When a grease gun is shown, wipe the fitting clean, apply two or three shots of lithium base automotive grease, and wipe off excess grease. When an oil can is shown wipe the area clean, apply a few drops of oil (SAE 30), then wipe up drips or spills.

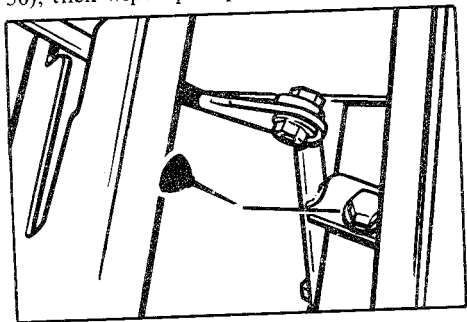

Figure 9. Shift Lever Lubrication

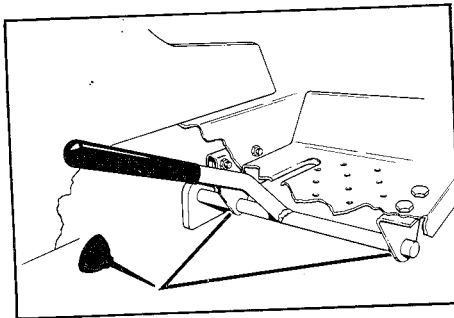

Figure 10. PTO Lever Lubrication

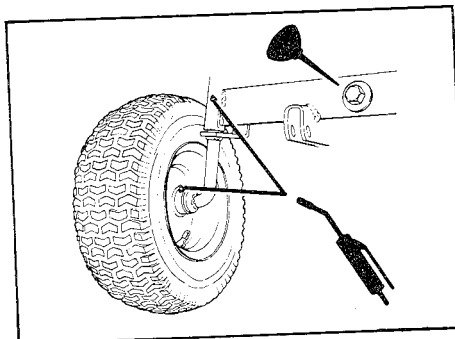

Figure 11. Front Axle Lubrication (Two grease fittings on each side)

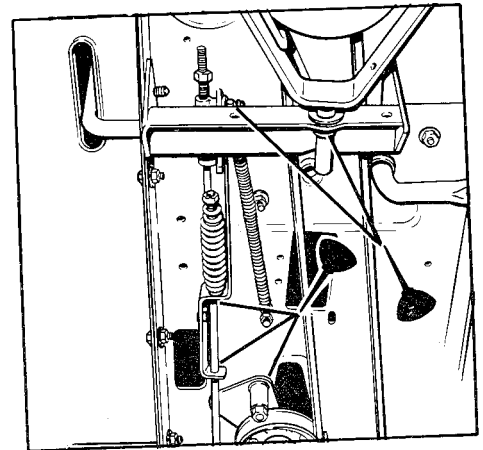

Figure 12. Clutch & Brake Rod Lubrication

CHECKING THE FUEL FILTER

WARNING

Do not remove fuel filter when engine is hot, as spilled gasoline may ignite. Do not spread hose clamps further than necessary. Insure clamps grip hoses firmly over filter after installation.

Normal Care

The fuel filter is located in fuel line between fuel tank and carburetor. If filter is dirty or clogged, replace as follows. Place a container below filter to catch spilled gasoline.

1. Using a pliers, open and slide hose clamps from fuel filter.
2. Remove hoses from filter.
3. Install new filter in proper flow direction in fuel line. Secure by reclamping with hose clamps. See warning at beginning of procedure.

CHECKING BATTERY FLUID

1. Raise the seat.
2. Remove filler caps, one at a time.
3. Fluid must be even with split ring full mark (figure 13). If not, add distilled water.
4. Reinstall filler caps.

CLEANING THE BATTERY & CABLES



WARNING

Be careful when handling the battery. Avoid spilling electrolyte. Keep flames and sparks away from the battery.



WARNING

When removing or installing battery cables, disconnect the negative cable **FIRST** and reconnect it **LAST**. If not done in this order, the positive terminal can be shorted to the frame by a tool.

1. Disconnect the cables from the battery, negative cable first (figure 13).

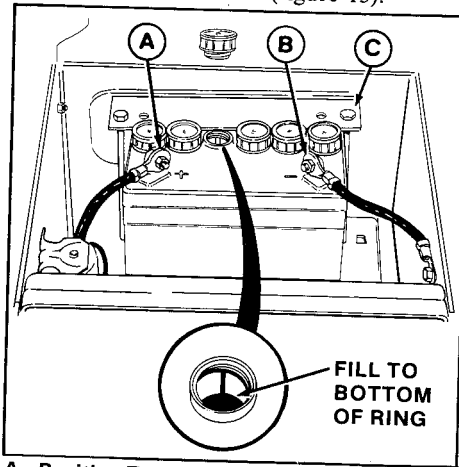

A. Positive Terminal

B. Negative Terminal

C. Battery Clamp

Figure 13. Battery

2. Remove the battery clamp, then remove the battery.
3. Scrub the battery, cables, and battery compartment with baking soda and water.
4. Clean the battery terminals and cable clamps with a wire brush.
5. Reinstall battery and clamp (figure 13).
6. Connect cables, positive cable first.
7. Coat cable clamps and terminals with grease or petroleum jelly.

CHECKING TIRE PRESSURE

Check air pressure of all four tires. Front tires should be 12 to 15 psi. Rear tires should be 6 to 8 psi. A gauge with one-pound markings will be necessary for an accurate check.

TRACTOR NORMAL STORAGE

Clean all grass and dirt from the mower. To protect your tractor, store it in an enclosed dry area. Do not store it in an enclosure where fumes from the fuel tank could reach an open flame. Clean the seat with a vinyl cleaner.

Normal Care

To store your tractor in a cold area between winter snow removal jobs, we suggest that you fill the fuel tank at the completion of each job to prevent water condensation in the fuel tank. Wait for engine to cool before filling tank.

TRACTOR OFF-SEASON STORAGE

When the tractor is to be stored for two months or longer, take precautions as follows:



WARNING

Gasoline is highly flammable. Keep open flame or spark away from gasoline and fuel tank. Never store tractor where gasoline fumes may reach an open flame or spark.

1. To empty or prepare fuel tank:
 - a. Run tractor engine until it stops from lack of fuel, or;

- b. Use a gasoline stabilizer. This additive, available from your dealer, prevents formation of gum and varnish for up to one year. With the additive, fuel may remain in your tank for long periods.
2. Change engine oil while the engine is still warm. Record the type and weight of oil put in crankcase.
3. Remove spark plug(s). Pour one ounce (30 ml) of SAE 30 oil into engine through spark plug hole(s). Crank engine a few times to distribute oil and then reinstall the spark plug(s).
4. Lubricate the tractor. (See page 11).
5. Check battery fluid level (page 12). Battery life will be extended if it is removed and stored in a cool, dry place, fully charged.
6. Clean tractor thoroughly. Coat all exposed bare metal parts with a good quality paint (obtainable from your dealer) or a light film of grease or oil.

STARTING AFTER STORAGE

1. Replace battery, if removed. Be sure terminals and clamps are clean (see page 12).
2. Remove the spark plug and wipe dry. Crank engine a few times to blow excess oil out of plug hole. Reinstall the plug.
3. Fill fuel tank with fresh gasoline (unless a fuel stabilizer was used).
4. Clean engine fins and air filter. (See engine manual.)
5. Check fluid levels and tire pressure. (See Normal Care Chart.)
6. Start the engine outdoors. Do not run engine at high speeds immediately after starting.

LUBRICATING THE MOWER

Lubricate the mower as shown in figure 14 thru 16. Use an oil can with medium weight (SAE 30) oil. Brush and wipe dirt and grass from the area before applying oil. Wipe up drips and spills. Keep oil off belts and pulleys.

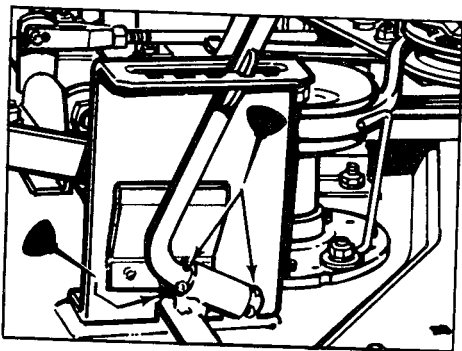

Figure 14. Lubricate Height Control Lever & Point Where Roller Bar Contacts Bracket.

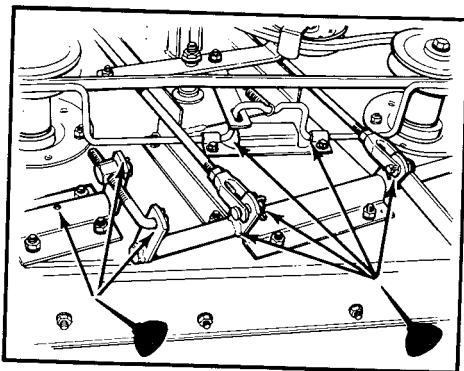

Figure 15. Lubricate Brake Lever, Clevises, & Levelling Rod.

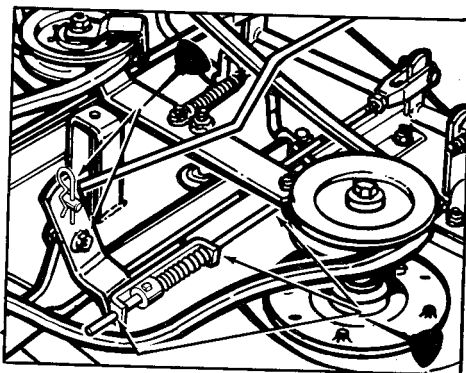

Figure 16. Lubricate Hitch, PTO Rod and PTO Arm

SHARPENING & BALANCING THE BLADES

1. Remove the mower from the tractor.
2. Position the mower as in figure 17. Secure the mower so it will not fall or slide.



WARNING

Do not handle the mower blades with bare hands. Avoid touching the cutting edge. Careless or improper handling of blades may result in serious injury.

3. Remove any dirt or foreign matter from inside the mower deck and blade.
4. To remove the blade for sharpening use a wooden block to hold blade while removing the capscrew (figure 17).
5. Use a file to sharpen blade to fine edge. Remove all nicks and dents in blade edge. If blade is severely damaged, it should be replaced.

USE PIN THROUGH HOLE
IF ARBOR TURNS

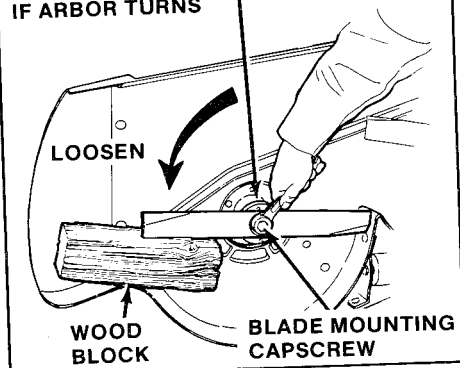

Figure 17. Removing Blade

6. Check and balance blade. Use a balancing machine or the fixture shown in figure 18. Center the blade on a nail lubricated with a drop of oil. A balanced blade will remain level. File material off heavier end of blade until it is balanced.
7. Reinstall each blade with the tabs pointing up toward deck and secure with a cap screw, cup washer, and spline washer. Be sure all splines are aligned and washer is flush against blade. Use a wooden block to prevent blade rotation

and torque cap screw to 55 ft. lbs. (74 N.m) (figure 19).

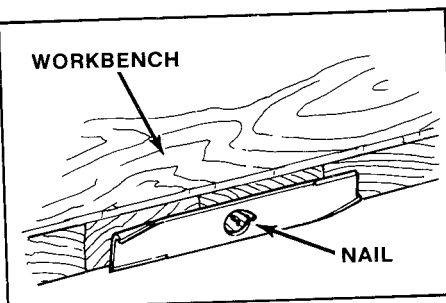

Figure 18. Balancing Blade

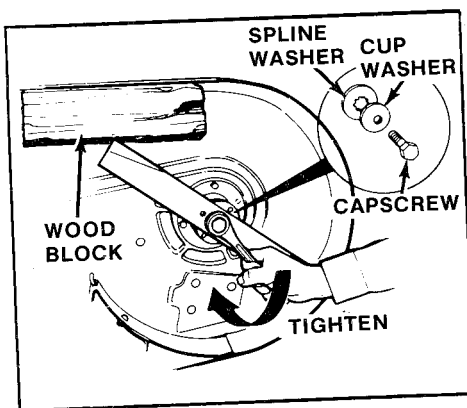

Figure 19. Installing Blade



WARNING

Blade mounting cap screws must be installed with the cup washer and spline washer and then securely tightened. Torque blade mounting cap screws to 55 ft. lbs. (74 N.m).

MOWER OFF-SEASON STORAGE

To protect your mower, store it in an enclosed dry area. To prepare the mower for off-season storage perform the following.

1. Remove mower from tractor if tractor is to be used without mower. (See Mower Installation and Removal section).
2. Clean top and underside of mower to remove all grass and dirt.
3. Coat all bare metal surfaces with a good quality paint (available from your dealer) or a light coat of oil to prevent rusting.
4. Lubricate mower (page 14).
5. Check, sharpen and balance the mower blades (page 14).
6. The belt should be stored in a cool, dark place away from sunlight or any heat source.

Troubleshooting & Repair

CONTENT OF SECTION

This section of the manual provides troubleshooting and repair instructions for the more common and easily corrected problems. For other problems, it is recommended that you contact your dealer.



WARNING

To avoid serious injury, perform maintenance on the tractor or mower only when the engine is stopped and the parking brake engaged. Always remove the ignition key and disconnect spark plug wire and fasten away from the plug before beginning the maintenance to prevent accidental starting of the engine.

TROUBLESHOOTING PROCEDURES

Troubleshooting procedures are provided in Table 2. To use these procedures, first locate the problem description that best describes the trouble that you have encountered. Check the possible causes one at a time in the order that they are listed.

1. **Engine will not start.**
 - A. Gear shift lever not in neutral start position. Shift into neutral.
 - B. PTO clutch lever not disengaged. Disengage fully.
 - C. Out of fuel. Refill fuel tank.
 - D. Engine flooded. Move control out of choke, & attempt to start.
 - E. Circuit breaker tripped. Wait one minute for automatic reset. Replace if defective (see your dealer).
 - F. Battery terminals require cleaning. See Normal Care section.
 - G. Battery discharged or dead. Recharge or replace.
 - H. Wiring loose or broken. Visually check wiring & replace broken or frayed wires. Tighten loose connections.
 - I. Solenoid or starter motor faulty. Repair or replace.
 - J. Safety interlock switch faulty. Replace if needed. (See your dealer.)
 - K. Spark plug or points faulty, fouled, or incorrectly gapped. Clean & gap or replace.
 - L. Water in fuel tank. Drain fuel & refill with fresh fuel.
 - M. Old stale gas. Drain fuel & replace with fresh fuel.
2. **Engine starts hard or runs poorly.**
 - A. Fuel mixture too rich. Move control out of choke. If problem still exists, clean air filter.
 - B. Carburetor adjusted incorrectly. See your engine manual.
 - C. Spark plug or points faulty, fouled, or incorrectly gapped. Clean and gap or replace.

Table 2. Troubleshooting

3. Engine knocks.

- A. Low oil level. Check/add oil as required.
- B. Using wrong grade oil. See Normal Care section.

4. Excessive oil consumption.

- A. Engine running too hot. Clean engine fins, blower screen and air cleaner. See Normal Care section.
- B. Using wrong weight of oil. See Normal Care section.
- C. Too much oil in crankcase. Drain excessive oil.

5. Engine exhaust is black or smoky.

- A. Dirty air filter. Clean air filter.
- B. Choke not fully open. Move control out of choke and be sure choke opens fully. If problem still exists, check carburetor adjustment.

6. Engine runs, but tractor will not drive or lacks power.

- A. Transmission not in gear. Shift into gear.
- B. Drive belt slips. (See problem and cause below.)

7. Drive belt slips.

- A. Clutch or belt tension is out of adjustment. See Adjustment section.
- B. Pulleys or belt greasy or oily. Clean as required.
- C. Belt stretched or worn. Replace with correct belt.
- D. Clutch rod binding in guide. Oil clutch rod. See Tractor Lubrication.

Table 2. Troubleshooting (Cont'd)

8. Brake will not hold.

- A. Brake is incorrectly adjusted. See Adjustment section.
- B. Brake pads worn & require replacement. See your dealer.

9. Tractor handles poorly.

- A. Steering linkage is loose. Check and tighten any loose connections.
- B. Improper tire inflation. Check and correct.
- C. Wheels are spinning and slipping. Use weights to provide additional stability and traction.
- D. Moving too fast on slopes. Reduce speed.

10. Main tractor drive belt does not stop when clutch-brake pedal is depressed.

- A. Belt stops out of adjustment. See Adjustments section.
- B. Belt tension out of adjustment. See Adjustments section.

TROUBLESHOOTING (MOWER)

1. Mower will not raise.

Lift chain not attached or broken. Attach or repair.

2. Uneven cut.

- A. Mower not leveled properly. See leveling adjustment in Mower Adjustment section.
- B. Tractor tires not inflated equally or properly.

3. Mower cut is rough looking.

- A. Engine speed too slow. Set for three-fourths to full speed.
- B. Tractor ground speed too fast. Use lower gear.

Troubleshooting & Repairs

3. Mower cut is rough looking. (Cont'd.)

- C. Blades dull & require sharpening. See Normal Care section.
- D. Mower drive belt slipping. Belt oily or worn. Clean or replace belt as necessary. Readjust belt tension.

4. Engine stalls easily with mower engaged.

- A. Tractor ground speed too fast. Use lower gear.
- B. Engine Speed too slow. Set for three-fourths to full speed.
- C. Cutting height set too low when mowing tall grass. Cut tall grass at maximum cutting height during first pass.
- D. Discharge chute jamming with cut grass. Cut grass with discharge pointing toward previously cut area.

5. Excessive mower vibration.

- A. Blade mounting screws are loose. Torque to 55 ft.lbs. (74 N.m). See Normal Care section.
- B. Mower blades, arbors, or pulleys are bent. Check and replace as necessary.
- C. Mower blades are out of balance. Remove, sharpen, and balance blades (see Normal Care section).

6. Excessive belt breakage.

- A. Belt tension too tight. Readjust belt tension.
- B. Bent or rough pulleys. Repair or replace.
- C. Using incorrect belt. See your dealer.

7. Mower drive belt slips or fails to drive.

- A. Mower drive belt out of adjustment. See Adjustment section.
- B. Mower drive belt broken. Replace belt.

Table 2. Troubleshooting (Cont'd.)

BATTERY REPLACEMENT

A dead battery or one too weak to start the engine may not mean the battery needs to be replaced. It may, as an example, mean that the charging system is not working properly or that the battery has lost its charge during storage. First,, "Clean Battery & Cables" and "Check Battery Fluid Level" as described on page 12. Have the battery recharged if necessary. If there is any doubt about the cause of the problem, see your dealer. If you must replace the battery, remove and install the battery as described in "Clean Battery & Cables".

JUMP STARTING WITH AUXILIARY (BOOSTER) BATTERY

Jump starting is not recommended. First, check the battery as described in "Battery Replacement" above. If jump starting must be done, follow these instructions. Both booster and discharged batteries should be treated carefully when using jumper cables. Follow exactly procedures one through five, being careful not to cause sparks.



WARNING

For your personal safety use extreme care when jump starting. Never expose battery to open flame or electric spark — battery action generates hydrogen gas which is flammable and explosive. Do not allow battery acid to contact skin, eyes, fabrics, or painted surfaces. Batteries contain a sulfuric acid solution which can cause serious personal injury or property damage.

1. Set parking brake and place transmission in "NEUTRAL". Turn off lights and other electrical loads.
2. Remove vent caps from both the booster and the discharged batteries. Lay a cloth over the open vent wells on each battery. These two actions help reduce the explosion hazard always present in either battery when connecting a "live" battery to a "dead" battery.

3. Attach one end of one jumper cable to the positive terminal of the booster battery (identified by a red color, "+" or "P" on the battery case, post or clamp) and the other end of same cable to positive terminal of discharged battery. DO NOT permit vehicles to touch each other, as this could establish a ground connection.
4. Attach one end of the remaining cable to the negative terminal (black color, "-" or "N") of the booster battery, and the other end to a bare metal surface on the frame of your tractor AWAY FROM the battery compartment (do not connect directly to negative post of dead battery). Take care that clamps from one cable do not inadvertently touch the clamps on the other cable. Do not lean over the battery when making this connection.
5. The tractor with the discharged battery should now start.

Reverse the jump starting procedure exactly to remove the jumper cables. Then reinstall the vent caps and throw the cloths away as they may have corrosive acid on them.



WARNING

Any procedure other than the above could result in: (1) personal injury caused by electrolyte squirting out of the battery vents, (2) personal injury or property damage due to battery explosion, (3) damage to the charging system of the booster vehicle or the immobilized vehicle.

Do not attempt to jump start a vehicle having a frozen battery because the battery may rupture or explode. If a frozen battery is suspected, examine all fill vents of the battery. If ice can be seen or if the electrolyte fluid cannot be seen, do not attempt to start with jumper cables as long as the battery remains frozen.

TRACTOR DRIVE BELT REPLACEMENT



CAUTION
To avoid damaging belt do not pry belt over pulleys.

1. Set the parking brake.
2. Remove mower from tractor.
3. Remove the nut, washers, and capscrew (A, figure 20) from the gear shift lever (B). Remember position of hardware for reinstallation.

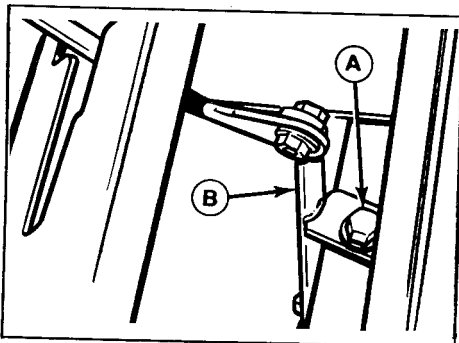

A. Hardware B. Gear Shift Lever

Figure 20. Gear Shift Lever

4. Remove the belt guide from the idler pulley (figure 21).

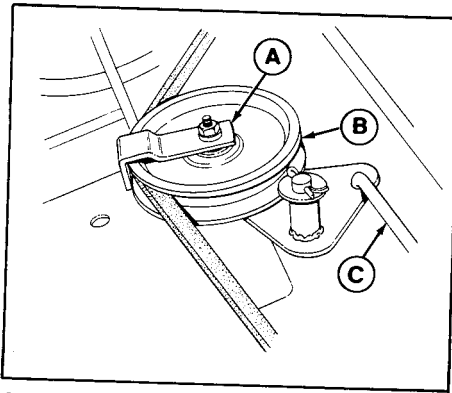

A. Belt Guide
B. Idler Pulley
C. Clutch Rod

Figure 21. Removing Belt Guide

5. Remove the belt from the engine drive pulley and idler pulley.
6. Turn the belt sideways to slip it off the transmission pulley and remove belt from tractor by slipping it over the gear shift lever.

7. Install the new belt in reverse order of removal procedure. The belt pattern is shown in figure 22.
8. Install the nut, washers, and capscrew at gear shift lever (figure 20). Reinstall the belt guide (figure 21). The belt guide should be positioned in the center area of belt portion that contacts pulley. The belt should not touch the guide when tractor clutch is engaged.

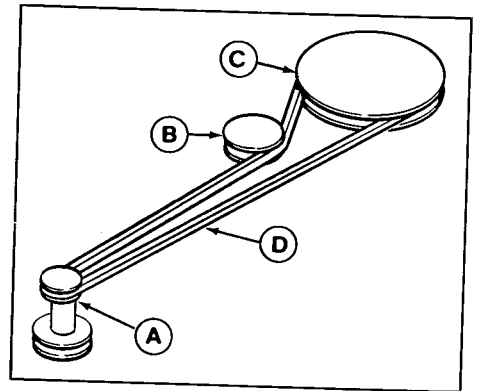

A. Engine Pulley C. Transmission Pulley
B. Idler Pulley D. Drive Belt

Figure 22. Tractor Belt Pattern

Troubleshooting & Repair

MOWER BELT REPLACEMENT



CAUTION

To avoid damaging belt do not pry belt off pulleys.

1. Remove mower from the tractor.
2. Loosen the belt guide (C, figure 23) on the idler pulley.
3. Remove the belt from the pulleys.
4. Install the new belt on the pulleys as shown in figure 24.
5. Reposition the belt guide on the idler pulley (figure 23). Before tightening the nut (D), position the belt guide so it is 1/4 inch (6 mm) behind the idler arm (B) when viewed from above (figure 23). Hold the belt guide when tightening nut.
6. Reinstall the mower on the tractor (see Mower Installation). Check mower drive belt tension as outlined in the Adjustment section. Run the mower under no load conditions for about 5 minutes and recheck the mower drive belt tension.

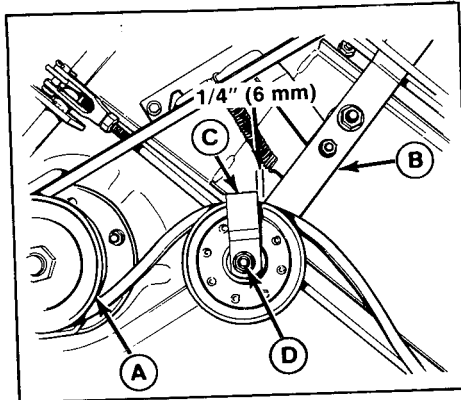

- A. Arbor Pulley
- B. Idler Arm
- C. Belt Guide
- D. Nut

Figure 23. Mower Belt Replacement

NOTE

Each time after changing the mower belt tension, perform the remaining mower adjustments: Right-Arbor Belt Stop, Idler Pulley Belt Guide and PTO Pulley Belt Stops.

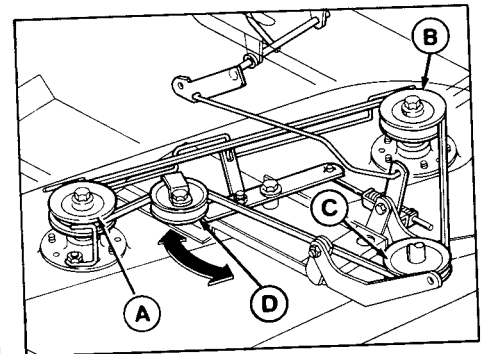

- A. V-Pulley, Right Arbor
- B. V-Pulley, Left Arbor
- C. Engine PTO Pulley
- D. Flat Idler Pulley

Figure 24. Mower Belt Pattern - 36"

Adjustments

WARNING

To avoid serious injury, perform adjustment only with engine stopped, key removed, and tractor on level ground.

TRACTOR ADJUSTMENTS-Model 4208, serial number 7974 and higher, Model 4211, serial number 11452 and higher.

For these tractors perform steps 1, 2, 3 and 4.
For earlier tractors, see page 23.

1. Adjust parking brake as follows:
 - a. Place the transmission in gear and release the parking brake. Move the brake rod (I, figure 26) back and forth to be sure there is no tension on the brake pads.
 - b. Push the cam lever (A, figure 25) forward (toward front of tractor) to take out any slack. The gap between lever (A) and stop (B) should be 1/8 inch (0.3 mm). Use a feeler gauge to measure. If not 1/8 inch, perform step "c".

- c. Loosen the locking nut (C). Tighten the adjusting nut (D) to decrease gap or loosen nut to increase gap. Re-check the measurement. When correct, tighten locking nut against adjusting nut.

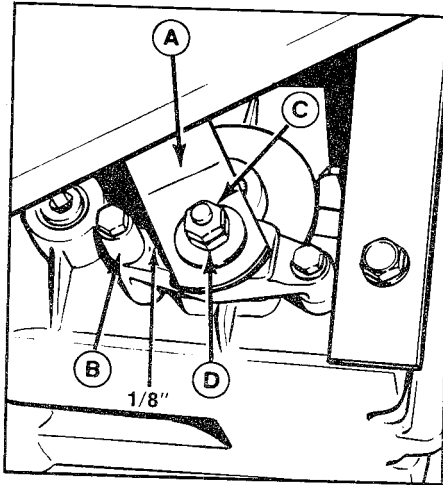

A. Brake Cam Lever
B. Stop
C. Locking Nut
D. Adjusting Nut

Figure 25. Parking Brake Adjustment

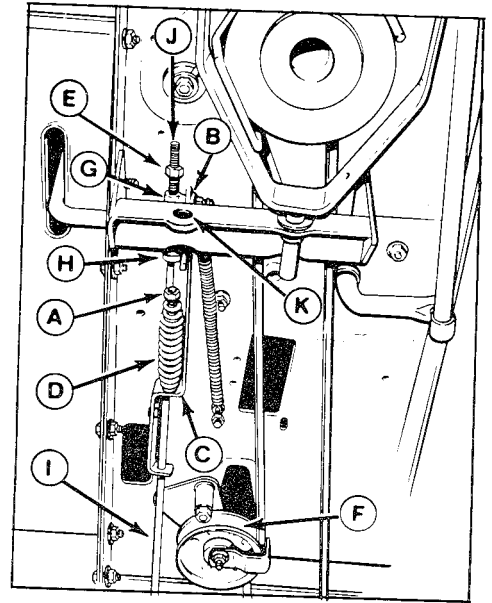

A. Nut
B. Slot (in brake rod guide)
C. Brake Rod Guide
D. Spring
E. Nut
F. Idler Pulley
G. Clutch Rod Guide
H. Set Collar
I. Brake Rod
J. Clutch Rod
K. Hole, 3/4" Dia.

Figure 26. Brake-Clutch Adjustment

2. Adjust brake rod as follows:

The clutch-brake pedal must be in up position. With one hand, push rod guide (C, figure 26) as far forward as slot (B) will allow while pulling rod (I) back with other hand. With rod guide in this position, tighten or loosen nut (A) until 1/4 inch (6.3 mm) of clearance is obtained between nut and end of spring.

3. Adjust clutch rod as follows:

- a. With the pedal up, push the idler pulley (F, figure 26) firmly against the belt. With the pulley in this position, the gap between nut (E) and the rod guide (G) should be 7/8 to 1 inch (22 to 25 mm). If not, tighten nut (E) to decrease gap or loosen nut to increase gap. Recheck the measurement.
- b. Depress and lock the clutch-brake pedal. Loosen the setscrew in the set collar (H). Move the collar against the spring which is located between collar (H) and rod guide (G). Be sure

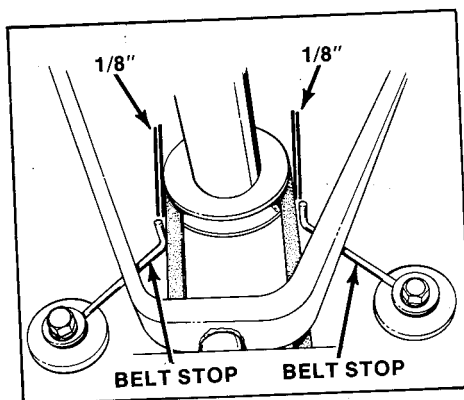

Figure 27. Drive Pulley Belt Stops

spring is seated as far as possible over rod guide (G). Push the collar 1/4 to 3/8 inch (6.3 to 9.5 mm) farther to compress the spring and tighten the setscrew. (When moving the set collar be careful not to move the rod.)

4. Adjust drive pulley belt stop as follows:

There should be 1/8 inch (3 mm) between each belt stop and the belt when the tractor clutch is engaged (pedal up). See figure 27.

TRACTOR ADJUSTMENTS-Model 4208, serial numbers lower than 7974. Model 4211, serial numbers lower than 11452.

NOTE

If tractor has a 3/4 inch diameter hole (K, figure 26) in bracket shown, use the preceding tractor adjustments (for higher serial numbers). If not, perform following steps 1, 2, 3 and 4).

1. Adjust parking brake as follows:

- a. Place the transmission in gear and release the parking brake. Move the brake rod (I, figure 26) back and forth to be sure there is no tension on the brake pads.
- b. Push the cam lever (A, figure 25) forward (toward front of tractor) to take out any slack. The gap between lever (A) and stop (B) should be 1/8 inch (0.3 mm). Use a feeler gauge to measure. If not 1/8 inch, perform step "c".
- c. Loosen the locking nut (C). Tighten the adjusting nut (D) to decrease gap or loosen nut to increase gap. Re-

check the measurement. When correct, tighten locking nut against the adjusting nut.

2. Adjust brake rod as follows:

The clutch-brake pedal must be in up position. With one hand, push rod guide (C, figure 26) as far forward as slot (B) will allow while pulling rod (I) back with other hand. With rod guide in this position, tighten nut (A) against spring until is snug but not compressed.

3. Adjust clutch rod as follows:

a. With the pedal up, push the idler pulley (F, figure 26) firmly against the belt. With the pulley in this position, the gap between nut (E) and rod guide (G) should be $9/16$ to $5/8$ inch (14 to 15 mm). If not, tighten nut (E) to decrease gap or loosen nut to increase gap. Recheck the measurements.

b. Depress and lock the clutch-brake pedal. Loosen the setscrew in the set collar (H). Move the collar against the spring which is located between collar (H) and rod guide (G). Be sure

spring is seated as far as possible over rod guide (G). Push the collar $7/16$ to $9/16$ inch farther to compress the spring and tighten the setscrew. (When moving the set collar be careful not to move the rod).

4. Adjust drive pulley belt stop as follows:

There should be $1/8$ inch (3 mm) between each belt stop and the belt when the tractor clutch is engaged (pedal up). See figure 27.

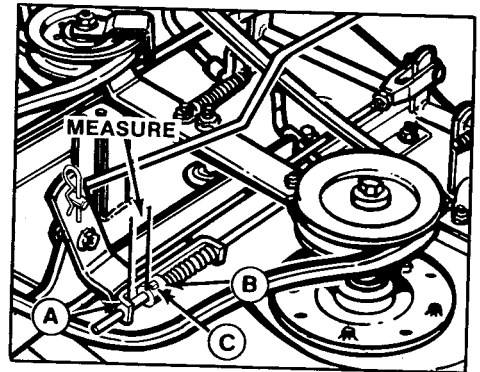

A. Rod Guide
B. Set Collar
C. Setscrew

Figure 28. Drive Belt Tension

MOWER ADJUSTMENTS

Mower Drive Belt Tension

Using the mower lift lever, lower the mower. Using the height control lever, place the mower in highest cutting position. Place the PTO lever in engaged position. The gap between the rod guide (A, figure 28) and the set collar (B) should measure $3/8$ to $1/2$ inch (10 to 13 mm). If not, disengage the PTO. Loosen the setscrew (C). Move the rod forward to increase the gap or back to decrease the gap then tighten the setscrew. Engage the PTO and recheck the adjustment. Readjust if necessary.

Right-Arbor Belt Stop

There should be $1/8$ inch (3 mm) clearance between the belt stop (B, figure 29) and belt (A) when the PTO is engaged. If not, loosen the nut (C), move the belt stop, and tighten the nut. Recheck the measurement.

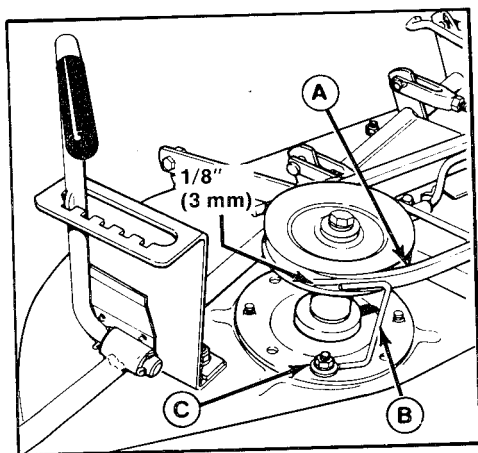

- A. Belt
- B. Belt Stop
- C. Nut

Figure 29. Right Arbor Belt Stop

Idler Pulley Belt Guide

The idler pulley belt guide is correctly adjusted when its edge is 1/4 inch (6 mm) from the rear edge of the idler arm (figure 30). If not, loosen the nut (C) and move the belt guide. Tighten the nut and recheck the measurement.

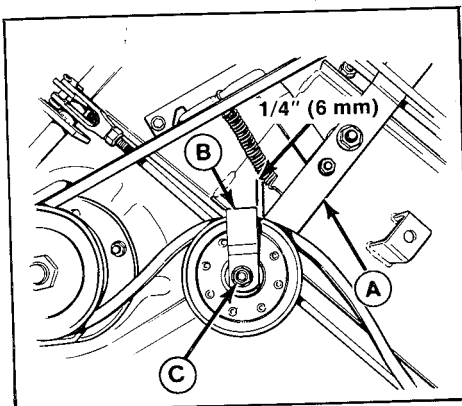

- A. PTO Idler Arm
- B. Belt Guide
- C. Nut

Figure 30. Idler Pulley Belt Guide

PTO Pulley Belt Stops

There are two belt stops at the PTO pulley; one on the left (figure 31) and one on the right (figure 32). With the PTO lever engaged, measure the distance between the belt stop and belt. There should be 1/16 inch (1.5 mm) clearance between each belt stop and the belt. To adjust a belt stop, loosen its mounting capscrew, move the belt stop, and retighten the capscrew. Recheck the measurement.

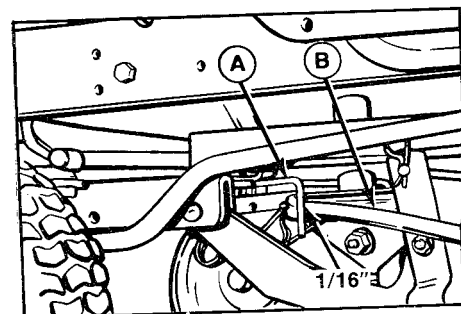

- A. Belt Stop
- B. Belt

Figure 31. Left PTO Pulley Belt Stop

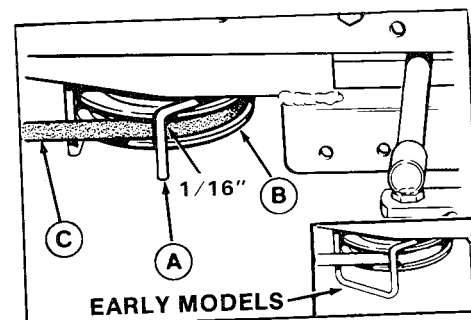

- A. Belt Stop
- B. PTO Pulley
- C. Belt

Figure 32. Right PTO Pulley Belt Stop

Adjustments

Levelling The Mower

If the cut is uneven, the mower may need levelling. Unequal or improper tire pressure may also cause an uneven cut.



WARNING

To prevent accidental starting, remove the ignition key and then remove the spark plug wire and fasten it away from the spark plug.

1. With the mower installed, place the tractor on a smooth level surface, such as a concrete floor. Turn the front wheels straight forward.
2. Check for bent blades, and replace if necessary.
3. Disengage the PTO. Arrange the mower blades so that they are both pointing from side-to-side, perpendicular to the tractor. Engage the PTO.
4. Measure the distance between the outside tips of each blade and the ground. If there is more than 1/8 inch (3 mm) difference between the measurements on each side, proceed to step 5. If there

is 1/8 inch (3 mm) or less difference proceed to step 6.

5. Remove the cotter pin (E, figure 33) which secures the mower levelling rod (D). Shorten the rod (D) to raise the left side of the mower or lengthen the rod to lower the left side of the mower. Put the levelling rod back in its hole and recheck the measurements. If the mower is level, install the cotter pin (E).
6. Disengage mower PTO to arrange the blades so they are facing front to back, parallel with the tractor. Engage mower PTO again.
7. Measure the distance to the ground from the front tip of the left blade and the rear tip of the right blade. The measurements should be equal. If they are not, proceed as follows.

NOTE

One full turn of clevis will equal about 1/8 inch.

8. Remove the cotter pins and pins (B) from the hitch clevises (C). Loosen the two nuts (A). Turn each clevis an equal

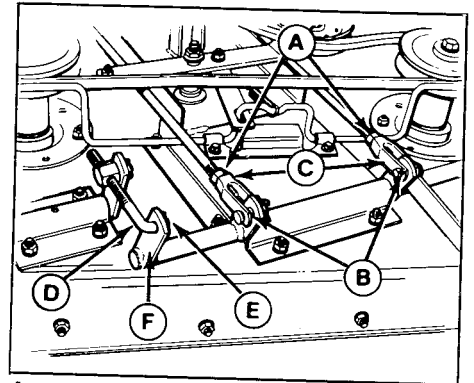

A. Jam Nuts D. Mower Levelling Rod
B. Pins E. Cotter Pin
C. Hitch Clevises F. Suspension Arm

Figure 33. Levelling Mower

number of turns in the same direction. Shorten the hitch rods to raise the front of the mower or lengthen the hitch rods to lower the front of the mower.

9. Reinstall the pins through the clevises (C) and rear suspension arm (F) and recheck the measurements. When the mower is level, reinstall the cotter pins and tighten nuts (A) against clevises (C).

Specifications

BASIC ENGINE

Make: Briggs & Stratton - 4 cycle, air cooled
Model (8 HP): #191707
(11 HP): #252707
Type (8 HP): 5646-01
(11 HP): 0130-01
Horsepower (8 HP): 8 HP @ 3600 rpm (Eng. Mfg's. Rating)
(11 HP): 11 HP @ 3600 rpm (Eng. Mfg's. Rating)
Cylinder: 1 horizontal
Bore & Stroke (8 HP): 3.00 x 2.75 inches (76 x 69 mm)
(11 HP): 3.44 x 2.62 inches (87 x 67 mm)
Displacement (8 HP): 19.44 cu. in. (319 cc)
(11 HP): 24.36 cu. in. (399 cc)
Crankshaft: Vertical, syncrobalanced
Battery (8 HP): 12 volt, 32 amp. hour
(11 HP): 12 volt, 39 amp. hour
Governor: Mechanical, full throttle - no load setting
@ 3400 ± 100 rpm; idle speed @ 1750 ± 200 rpm
Crankcase Capacity: See engine manual
Ignition: Flywheel magneto with breaker points
Charging: Unregulated 3-amp DC charging circuit
Air Cleaner: Oil foam with reuseable polyurethane element
Fuel Tank: 2.2 gallons (8.3 liters) of "regular" grade
or nonleaded gasoline.
Starter: 12 volt electric gear drive

TRANSMISSION

Type: Spur gear trans. w/5 speeds forward & 1 reverse

Differential: Bevel gear type

Ground speeds @ 3400 rpm:

1st Gear - 1.1 mph (1.8 Km/h)
2nd Gear - 1.8 mph (2.8 Km/h)
3rd Gear - 2.6 mph (4.3 Km/h)
4th Gear - 3.4 mph (5.4 Km/h)
5th Gear - 4.0 mph (6.4 Km/h)
Reverse - 1.3 mph (2.1 Km/h)

DIMENSIONS & WEIGHT

Height (at steering wheel): 39 in. (991 mm)
Width: 35.25 in. (895 mm)
Length: 65.25 in. (1.6 mm)
Clearance - Front Axle: 9.2 in. (234 mm)
Clearance - Transmission: 5.5 in. (139 mm)
Wheel Base: 45.5 in. (1156 mm)
Turning Radius: 24 in. (610 mm) to inside of rear wheel
Front Tires: 13 x 5.00 x 6 Pneumatic
Rear Tires (8 HP): 18 x 8.50 x 8 Pneumatic
(11 HP): 18 x 9.50 x 8 Pneumatic
Tractor Weight (8 HP): 309 lbs. (140 Kg)
(11 HP): 330 lbs. (150 Kg)
Shipping Weight W/Mower (8 HP): 505 lbs. (229 Kg)
(11 HP): 526 lbs. (238 Kg)

Optional Attachments

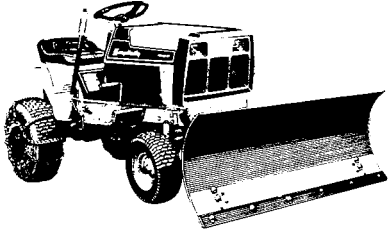

42" DOZER BLADE - For snow removal and light dozing of dirt, gravel, etc.

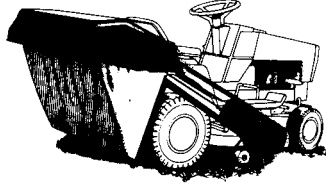

GRASS CATCHER - For the best lawn appearance.

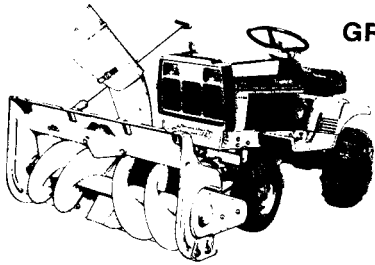

36" SNOWTHROWER - Efficient single stage operation to handle the heaviest of snows.

ENGINE DRIVEN VACUUM COLLECTOR - For big-job grass and leaf collection.

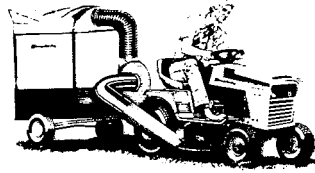

SNOW CAB - Shields operator from blowing snow and wind.

Optional Accessories

TIRE CHAINS for traction.

HOURLY METER to record operating time.

HEADLIGHTS to improve visibility.

SEAT SPRING KIT for operator comfort.

FRONT WEIGHT to improve steering and stability with rear mounted attachment.

REAR WHEEL WEIGHTS to improve traction and stability.

DUMP CART for vacuum collector and hauling chores.

ROVING NOZZLE used with vacuum collector to collect leaves in hard-to-reach places.

NOTE: Some attachments require accessories. See your dealer or the attachment operator's manuals.

Common Replacement Parts

Listed below are part numbers for the more common replacement parts. Use the order form at the back of the manual to order a complete, illustrated parts manual. Only genuine Simplicity replacement parts will assure optimum performance and safety. Do not attempt repairs or maintenance unless proper procedures and safety precautions are followed. For assistance in any area, see your dealer.

QTY PER UNIT	DESCRIPTION	PART NUMBER
1	Drive Belt — engine to transmission	1666698
1	Drive Belt - mower	108505
1	Keys - Ignition (2 keys with ring)	122203
2	Headlight Lens	**1665933
1	Interlock Switch - PTO	1654634
1	Interlock Switch - Transmission	1654634
2	Blade - Mower (standard)	1657589
1	Blade - Mower (use with grass catcher)	1685172
3	Cotter Pin - levelling clevises & rod	918447
1	Spring Cip - Mower PTO Rod	106787
1	Cotter Pin - Mower PTO Rod	918448
2	Hitch Pin - mower	156306
2	Safety Clips - for Hitch Pins	176012
1	39 amp. hr. Battery	1685215
1	Fuel Filter	173206
	Simplicity SAE5W-30 Cold Weather Engine Oil	1685518 (case of 12 qts.)

QTY PER UNIT	DESCRIPTION	PART NUMBER
	Grease Gun Kit	1685510
	8 Oz. Tube - for above	103077
	*Touch-Up Paint Orange, Spray Can	103262
	*Touch-Up Paint White, Spray Can	103049
	***Multi-Purpose Hydraulic/ Transmission Oil	1685516 (Case of 12 qts.)

Pneumatic Tire Seal - Stops Leaks
Available in following amounts:

5½ Oz. Tube	1685522
11 Oz. Tube	1685523
Case of 24-5½ Oz. Tubes	1685524
Case of 24-11 Oz. Tubes	1685525
Split Case - 12-5½ Oz. Tubes and 12-11 Oz. Tubes	1685526

*Also Available in 1/2 Oz. Brush Cap Daubers
**Purchase the bulb (#199) from a local automotive supplier
***See your dealer to buy individual quarts.

Maintenance Record

DATE	HOURS USED	LUBRICATION	MAINTENANCE/REPAIR

Simplicity Manufacturing, Inc.
500 N. Spring Street
P.O. Box 210
Port Washington, WI 53074

Copyright © 1983 *Simplicity Manufacturing, Inc.*

PRINTED IN U.S.A.