

Attachments & Accessories

REGENT
12LT/12RT
4000
5000
6000
GT



PARTS MANUAL

Simplicity[®]

Product Identification:

When ordering parts, keep your products serial number and manufacturer's number in mind. Variations may occur in a part between early & later model products, causing the product serial number to be listed in the parts description whenever these variations occur. Record your I.D. numbers here for quick, future reference.

Product Mfg. No. _____ S/N _____ Mower Mfg. No. _____ S/N _____

Attention:

Standard torques appear in a chart at the end of the manual, while important Individual torques are given on specific parts drawings. CRITICAL and MAJOR notations point out important facts or instructions which relate to personal safety and proper machine operation. Any CRITICAL notation [C] which may appear in this book, pinpoints characteristics which, if not properly followed, can create a safety hazard. Any MAJOR notation [M] which may appear in this book, marks characteristics which, if not properly followed, may result in operating failure, shortened product life, or greatly reduced quality of the unit. For your convenience, assembly notes are included in parts drawings to assist in repair and assembly of unit.

SIMPLICITY BRAND PRODUCTS**OILS - SPECIFICALLY BLENDED OF HIGH QUALITY BASE OILS & ADDITIVES.**

Special Worm Gear Oil: Required for protection of brass gears and mating parts.

• Cold Weather Worm Gear Oil for snowthrowers with worm gear drive. 8 Oz. Bottle, Part #1704636, Case of 12-8 Oz. Bottles, Part #1685406.

Multi-Purpose Hydraulic/Transmission Oil for use in most hydraulic applications, and hydrostatic transmissions. Specific Simplicity applications: All hydrostatic transmissions, all bevel gear cases. Case of 12 Quarts, Part #1685516, 2-1/2 Gallon Container, Part #1685539.

SAE 5W-30 SF/CD Cold Weather Engine Oil for use in all four cycle and diesel engines at 30° temp. and under. Case of 12 quarts, Part #1685576.

SAE 15W-40 SF/CD Engine Oil for gas and diesel engines, warm weather; see engine manufacturer recommendations. Case of 12 quarts, Part #1685554.

SAE 30W SG/CC Detergent Engine Oil for use in four cycle lawn and garden engines at operating temp. of 32° and above. Also recommended for use in hydrostatic transmissions where 30W oil is specified. Case of 12 quarts, Part #1685559.

DEGREASER, DEGRIMER, PARTS CLEANER removes grease, oil, dirt and grime without harming paint or decals.

1 Quart w/Trigger Spray	1685619
1 Gallon Bottle	1685621
Extension Sprayer for Gallon Bottle	1685623

TOUCH-UP PAINT keeps equipment in showroom condition.

Spray Cans	Quarts	Daubers-12 Per Ctn.
<i>For Products Built After 8/1/89.</i>		
"Deep Orange" 13 Oz. Can 1685611 Case 12 Cans 1685614	1685612	1685616 Mixed 6 Deep Or., 6 White 1/2 Oz. Bottles
"Gloss Black" 13 Oz. Can 1685639 Case 12 Cans 1685640	1685641	N/A
"White" 13 Oz. Can 103049 Case 12 Cans 1685178	1685032	See Above

Consult decal on equipment for proper color.

AVAILABLE ACCESSORIES:

DESIGNER SEAT COVERS are double stitched, easy care vinyl. Keeps new seats new, makes worn seats look new.

Small Seat Cover w/Pocket, Part #1685540. Fits all Rear Engine Riders, FC, RT Series Tractors.

Large Seat Cover w/Pocket, Part #1685541. Fits all 12.5 & 16 LT and GT Series Tractors.

Seat Cover, Part #1685577. Fits all 18 & 20 GTH Tractors.

PNEUMATIC TIRE SEAL seals all leaks including bead leaks and punctures up to 3/16 inch diameters. Prevents flats for tread life of tire. Available in following amounts.

Case of 12 -11 Oz. Tubes	1685537
Case of 24 -11 Oz. Tubes	1685525
5 Gallon Pail	1685527

HOURLY METER KIT, Part #1685535.

GREASE GUN KIT has 12" flexible hose to get into tight spots with ease. Kit contains: gun and 1-8 Oz. tube of grease. Part #1685510. For replacement tube, order Part #103077.

CHROME "Moon" Hubcaps

4" Rim	163114
6" Rim	156210
8" Rim	156211
10" Rim	1687782
12" Rim	154505

**Extend Equipment Life - Use Only Genuine Simplicity Parts & Accessories
Available at Your Local Simplicity Dealer**

Table of Contents

MFG.	DESCRIPTION	PAGE NO.
1600236	DUMP CART GROUP	24
1655230	REAR IMPLEMENT ATTACHMENT GROUP	78
1685201	HITCH BRACE KIT	84
1685535	HOURMETER KIT	86
1685336	SPRING ASSISTED LIFT KIT (42" DOZER)	76
1685337	SPRING ASSISTED LIFT KIT (36" & 42" SNOWTHROWER)	76
1690031	ROVING NOZZLE GROUP[.....	38
1690226	VACUUM COLLECTOR GROUP	
	HOUSING & ENGINE GROUP	28
	MISC. GROUP	30
1690227	42" & 48" VACUUM COLLECTOR ADAPTOR GROUP	36
1690228	36" VACUUM COLLECTOR ADAPTOR GROUP	36
1690257	FRONT COUNTERWEIGHT GROUP	86
1690389	ONE POINT HITCH GROUP	78
1690401	CART COVER & SIDE EXTENSION HITCH GROUP	26
1690464	HEADLIGHT KIT	82
1690556	SNOWTHROWER HITCH	
	HITCH GROUP	10
	MISC. GROUP	12
1690563	ENGINE DRIVEN VACUUM COLLECTOR GROUP	
	SINGLE WHEEL MODEL	32
	TWO WHEEL MODEL	34
1690624	WEIGHT BOX GROUP	88
1690821	DELUXE GRASS CATCHER	
	COVER, BAG & SUPPORT GROUP	46
	TUBE & BLADE GROUP	48
1691186	TURBO TWIN CATCHER	
	COVER, BAG & SUPPORT GROUP	46
	TUBE & SUPPORT GROUP	50
1691260	42" & 48" TURBO COLLECTION SYSTEM	40
1691277	30" OFFSET TILLER	
	DEFECTOR & TINE GROUP	14
	CLUTCH GROUP	18
	JACKSHAFT GROUP	16
	PULLEY GUARD GROUP	20
	CASE GROUP	22
1691356	36" TURBO COLLECTION SYSTEM	44
1691379	HITCH & LIFT KIT (TILLER)	82
1691467	LIFT LEVER GROUP	80
1691520	42" SNOW PLOW & DOZER GROUP	72
1691521	36" SNOWTHROWER	
	BODY & ROTOR GROUP	4
	DRIVE GROUP	6
	SPOUT GROUP	8
1691522	42" SNOWTHROWER	
	BODY & ROTOR GROUP	4
	DRIVE GROUP	6
	SPOUT GROUP	8
1691523	42" SNOW PLOW & DOZER BLADE HITCH GROUP	74

Table of Contents

MFG.	DESCRIPTION	PAGE NO.
1691524	CART COLLECTOR	
	CART GROUP	52
	COVER GROUP	54
	TUBE & BLADE GROUP	56
1691525	TURBO CART COLLECTOR	
	CART GROUP	52
	COVER GROUP	54
	TUBE & SUPPORT GROUP	58
1691531	ELECTRIC LIFT KIT	
	ELECTRIC LIFT GROUP	68
	POWER LIFT ASSEMBLY - SERVICE PARTS	70
1691688	QUADBAGGER DUMP CART	
	CART GROUP	60
	HITCH GROUP	62
1691699	QUADBAGGER	
	TUBE & PULLEY COVER GROUP	64
	COVER & SUPPORT GROUP	66
1691788	TWIN BAG GRASS CATCHER	
	COVER GROUP	90
	ADAPTER, BLADE & TUBE GROUP	92
	HITCH GROUP	96
1691793	TURBO TWIN BAG GRASS CATCHER	
	COVER GROUP	90
	ADAPTER, BLADE & TUBE GROUP	94
	HITCH GROUP	96
1691810	42" & 48" TURBO COLLECTION SYSTEM	40
1691811	QUAD BAGGER	98
1691999	36" TURBO COLLECTION SYSTEM	100
1692088	GRASS MULCHER & LEAF SHREDDER KIT FOR 36" MOWER	102
1692239	36" SNOWTHROWER HITCH	
	36" SNOWTHROWER GROUP	10
	36" & 42" MISC. HITCH GROUP	12
1692240	42" SNOW PLOW & DOZER BLADE HITCH	74
	STANDARD HARDWARE SPECIFICATIONS	INSIDE BACK COVER

NOTE: Attachments & accessories listed in this manual do not fit all models. Consult your dealer Service Information Manual to find the correct attachment/accessory designed for a specific model.

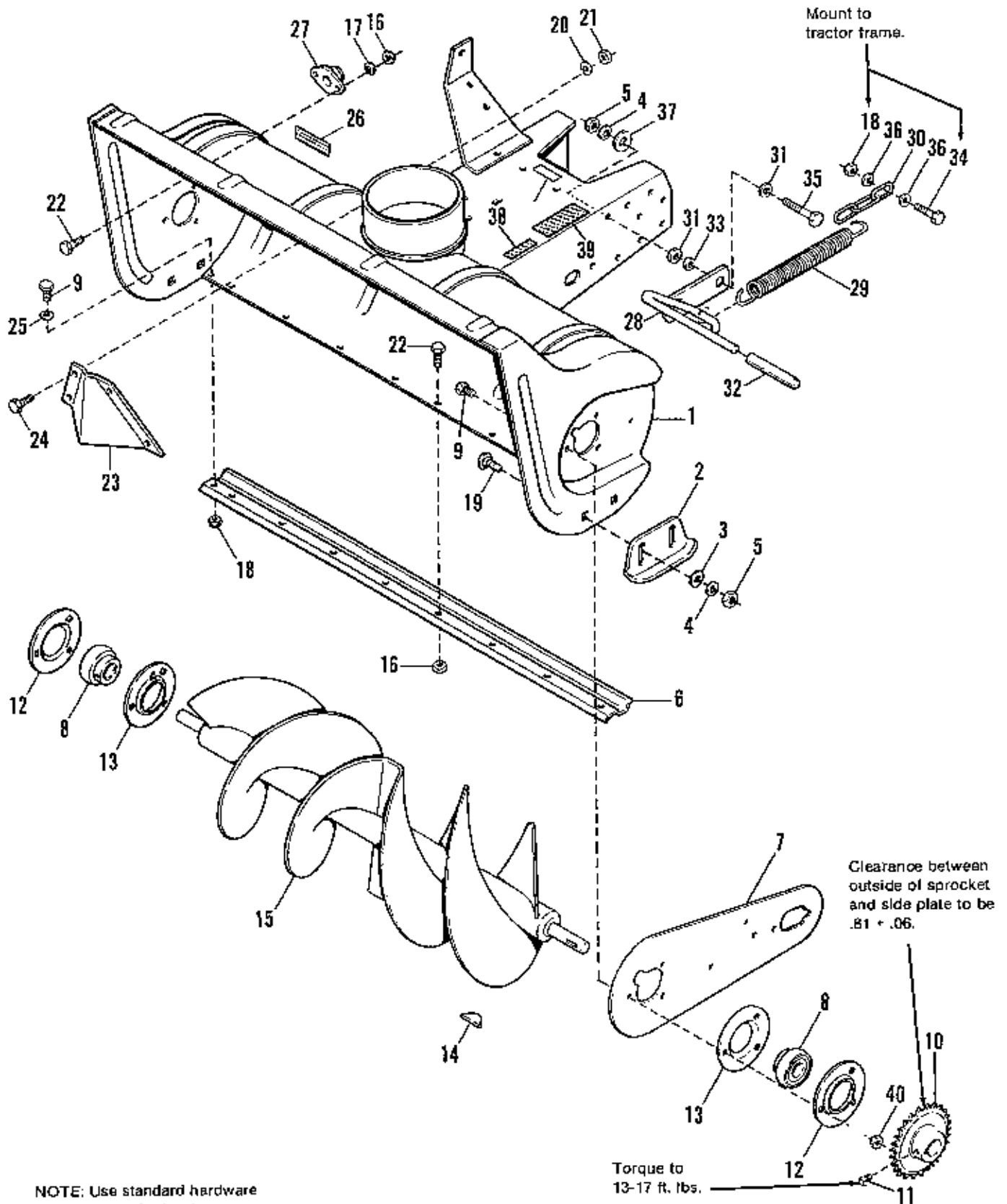

NOTE: Use standard hardware torque spec. chart unless otherwise noted.

Torque to 13-17 ft. lbs.

Clearance between outside of sprocket and side plate to be .81 + .06.

36" & 42" Body & Rotor Group

Ref. No.	Part No.	Qty.	Description
1	1666155	1	BODY & FRAME ASSY. (1691521 only)
	1666623	1	BODY & FRAME ASSY. (1691522 only)
2	177434	2	SKID
3	1924940	4	WASHER, Plain, 3/8
4	1916965	5	LOCKWASHER, 3/8
5	1916950	5	NUT, Hex, Full, 3/8-16
6	106683	1	SCRAPER, Body (1691521 only)
	106746	1	SCRAPER, Body (1691522 only)
7	1676632	1	PLATE, Side
8	173934	2	BEARING, Cartridge
9	1921332	8	CAPSCREW, Hex, 5/16-18 x 3/4
10	106653	1	SPROCKET, Rotor
11	1928721	1	SETSCREW, 5/16-18 x 3/4
12	172278	2	FLANGE, Bearing
13	172279	2	FLANGE, Bearing
14	151040	1	KEY
15	106856	1	ROTOR ASSY. (1691521 only)
	106748	1	ROTOR ASSY. (1691522 only)
16	1923358	9	NUT, Hex, Full 1/4-20 (Qty. 10 on 1691522)
17	1916964	2	LOCKWASHER, 1/4
18	1923362	3	LOCKNUT, Hex, 5/16-18
19	192210	4	CARRIAGE BOLT, 3/8-16 x 3/4
20	1917356	4	LOCKWASHER, 5/16
21	1917372	4	NUT, Hex, Full, 5/16-18
22	1921959	9	CAPSCREW, Hex, 1/4-20 x 5/8 (Qty. 10 on 1691522)
23	106774	1	DEFLECTOR
24	1925205	4	CAPSCREW, Hex, 5/16-18 x 5/8
25	1919326	2	WASHER, Plain, 1/4
26	1679206	1	DECAL, Safety
27	171388	1	BEARING
28	1701917	1	LEVER ASSY.
29	1675232	1	SPRING
30	1656835	1	LINK
31	1924356	2	WASHER
32	176934	1	GRIP
33	108717	1	SPACER
34	1921977	1	CAPSCREW, 5/16-18 X 1-1/4
35	1921969	1	CAPSCREW, Hex, 3/8-16 x 1-1/2
36	1919381	2	WASHER, Plain, 5/16
37	1922755	1	WASHER
38		1	I.D. PLATE
39	1701940	1	DECAL, Caution
40	1935048	6	NUT, Hex, Flange Lock, 5/16-18

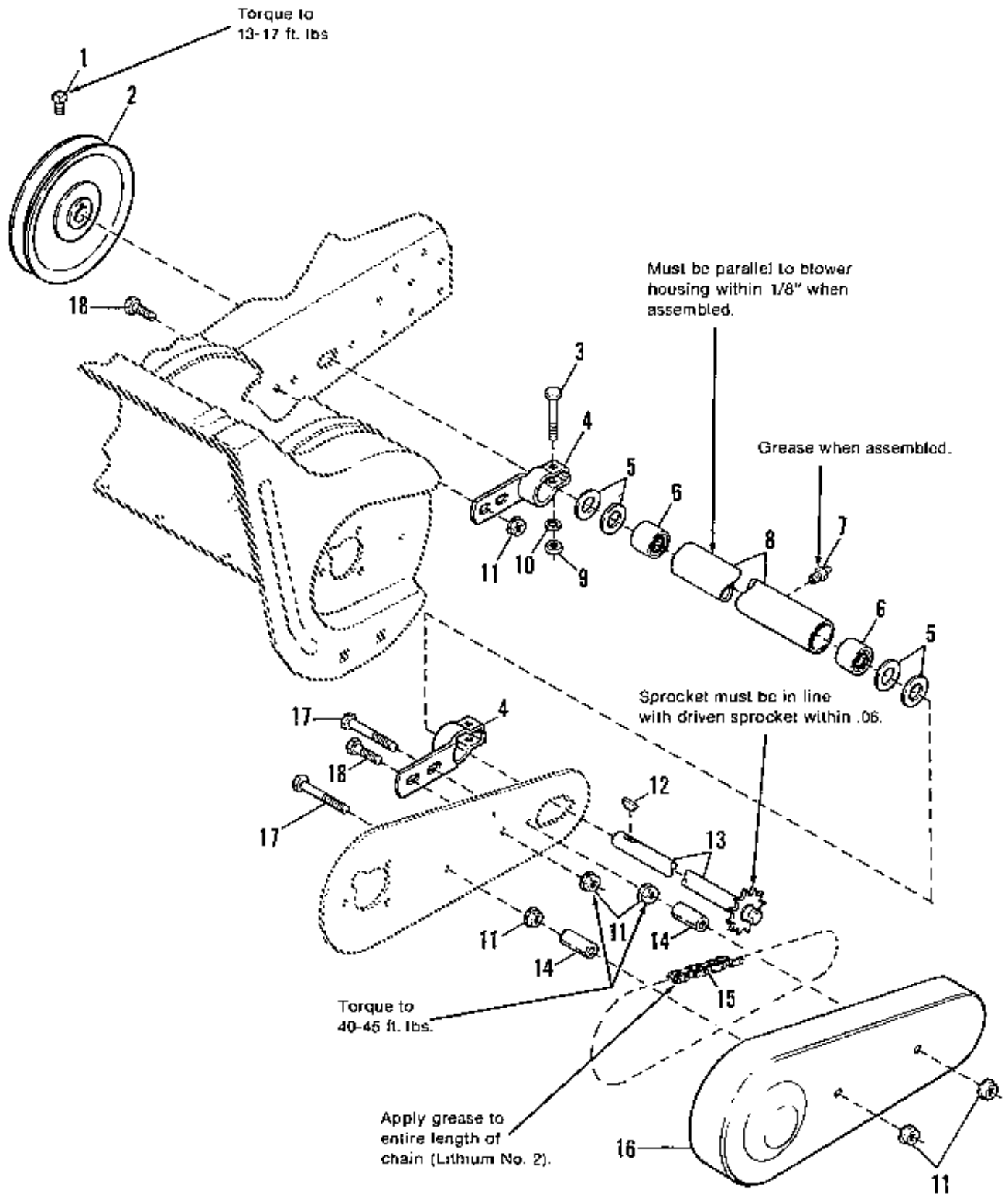

NOTE: Use standard hardware torque spec. chart unless otherwise noted.

36" & 42" Drive Group

Ref. No.	Part No.	Qty.	Description
1	1928721	1	SETSCREW, 5/16-18 X 1/2
2	171248	1	PULLEY
3	1922127	2	CAPSCREW, Hex, 5/16-18 x 1-3/4
4	1666145	2	CLAMP
5	8061012	4	WASHER
6	154258	2	BEARING, Needle
7	921133	1	FITTING, Grease
8	1651084	1	HOUSING ASSY., w/Bearings (1691521 only) (Incl. Ref. No. 6)
	1650955	1	HOUSING ASSY., w/Bearings (1691522 only) (Incl. Ref. No. 6)
9	1917372	2	NUT, Hex, Full, 5/16-18
10	1917356	2	LOCKWASHER, 5/16
11	1928352	7	LOCKNUT, Flange, 5/16-18
12	905123	1	KEY
13	106860	1	SHAFT ASSY., (1691521 only)
	106757	1	SHAFT ASSY., (1691522 only)
14	1669105	2	SPACER
15	171242	1	CHAIN (Auger Drive)
16	1676738	1	GUARD, Chain
17	1960244	2	SCREW, Hex, Whizlock, 3/8-16 x 2-3/4
18	1934654	3	SCREW, Hex, Whizlock, 3/8-16 x 1

Install clip
at approx. a 45°
angle to centerline
of rod.

Weld wire must be to
the rear of chute.

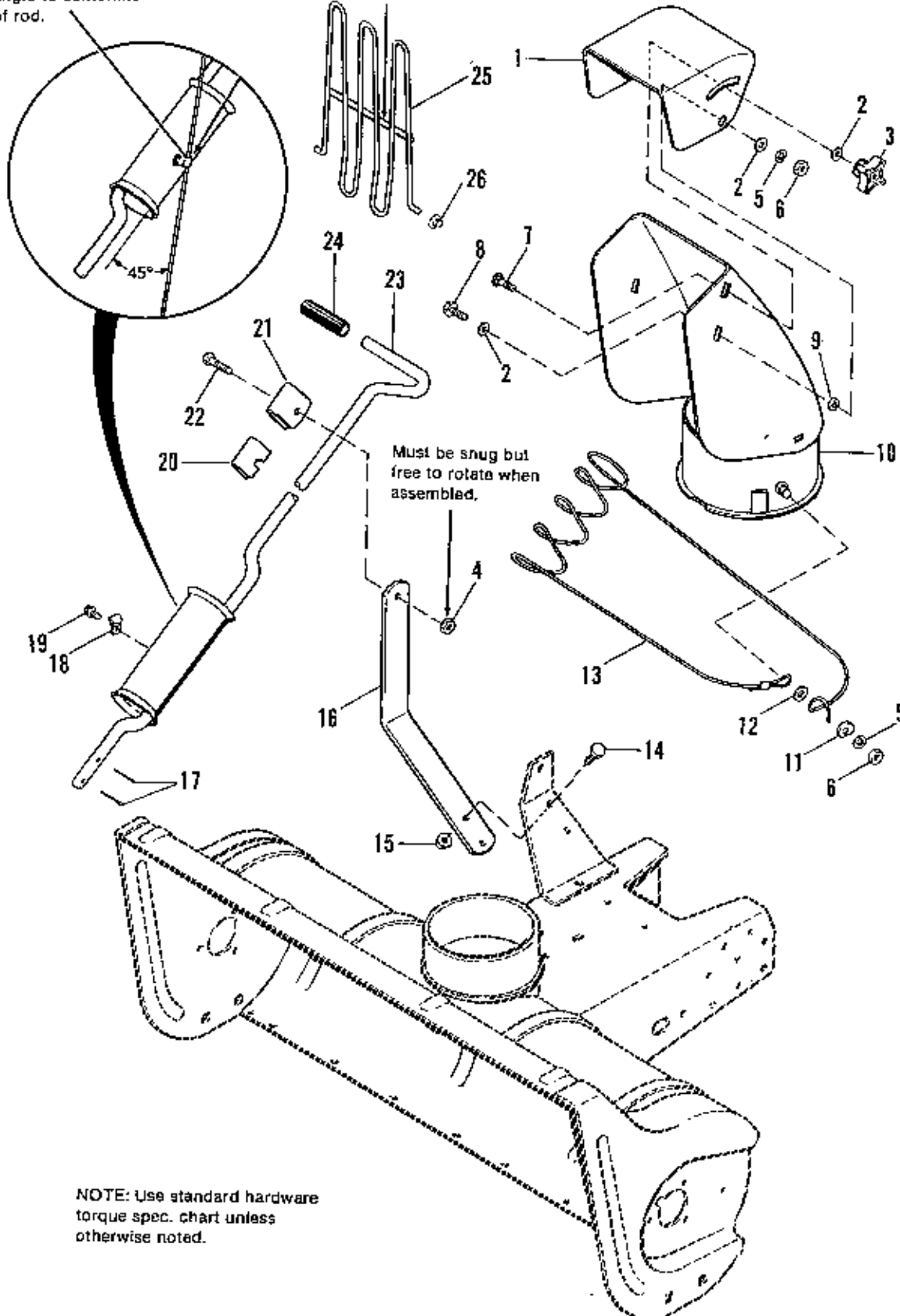

NOTE: Use standard hardware
torque spec. chart unless
otherwise noted.

36" & 42" Spout Group

Ref. No.	Part No.	Qty.	Description
1	1667791	1	DEFLECTOR
2	1917642	3	WASHER, Plain, 5/16
3	1670578	1	KNOB
4	1923362	1	LOCKNUT, Hex, 5/16-18
5	1917356	3	LOCKWASHER, 5/16
6	1917372	3	NUT, Hex, Full, 5/16-18
7	1920563	1	CARRIAGE BOLT, 5/16-18 X 1
8	1936482	2	CAPSCREW, Hex, 5/16-18 x 3/4
9	1667790	2	SPACER
10	1704294	1	CHUTE ASSY.
11	171379	1	WASHER, Cup
12	1919326	1	WASHER, Plain, 5/16
13	171362	1	CABLE ASSY.
14	1921210	3	CAPSCREW, Hex, 3/8-16 x 1
15	1930845	3	NUT, Hex, Flange, 3/8-16
16	1707522	1	ARM, Support
17	1918447	2	PIN, Cotter, 3/32 x 3/4
18	171382	1	CLAMP
19	1927428	1	SCREW, Hex, Tapitite, 1/4-20 x 3/8
20	121175	1	LINER
21	152050	1	GUIDE, Rod
22	1921221	1	CAPSCREW, Hex, 5/16-18 x 1-1/2
23	176333	1	ROD ASSY., Spout
24	176933	1	GRIP, Handle
25	1704446	1	GUARD ASSY., Chute
26	1960126	2	PUSH NUT

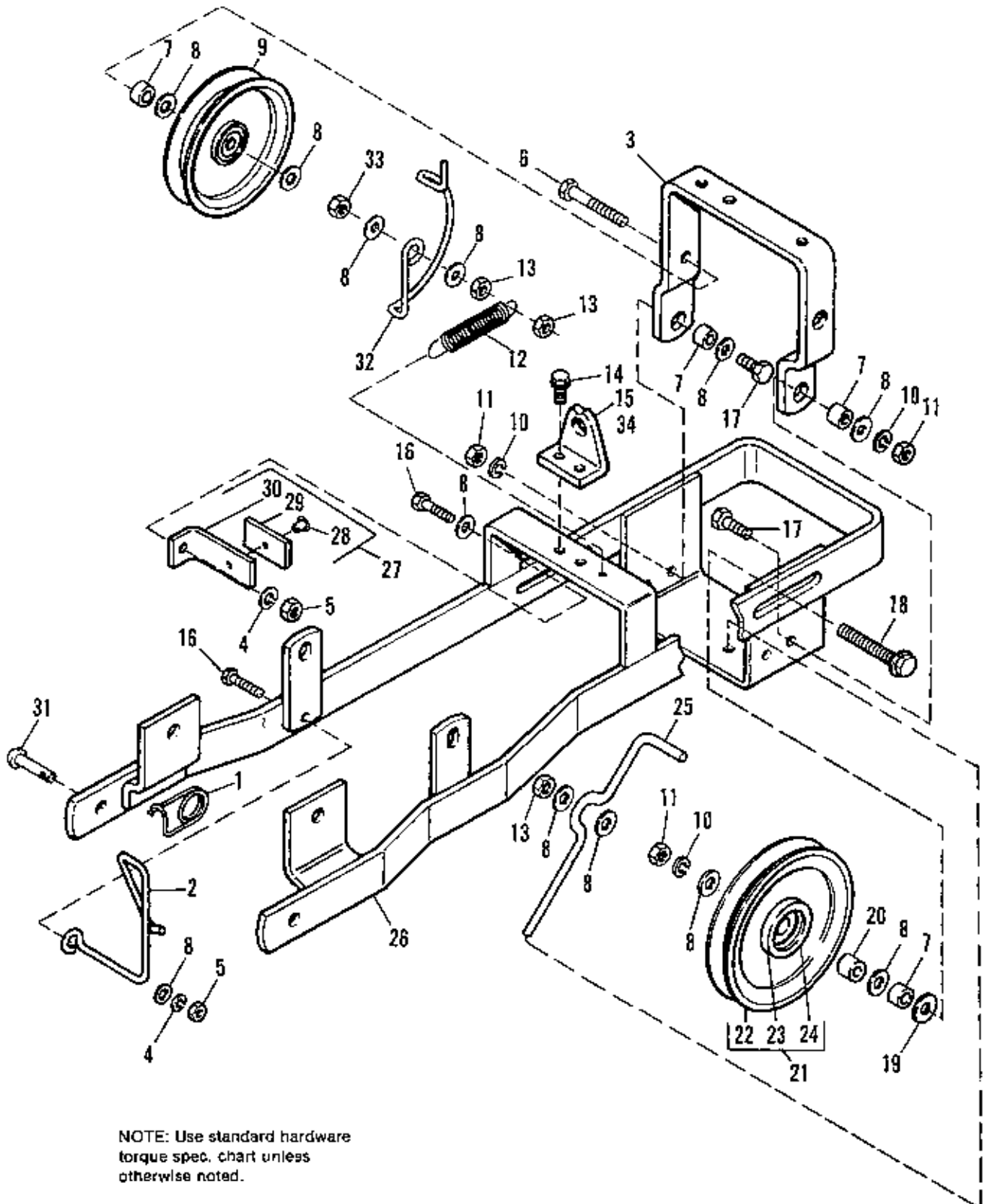

36" & 42" Snowthrower Hitch Group

Ref. No.	Part No.	Qty.	Description
1	176012	6	CLIP, Spring
2	1666149	1	STOP, Belt
3	1665198	1	PIVOT, Bracket
4	1917356	2	LOCKWASHER, 5/16
5	1917372	3	NUT, Hex, 5/16-18
6	1933685	1	CAPSCREW, Hex, Full Thread, 3/8-16 x 2-1/2
7	158227	4	SPACER
8	1917642	12	WASHER, Plain, 5/16
9	171247	1	PULLEY
10	1916965	4	LOCKWASHER, 3/8
11	1916950	4	NUT, Hex, 3/8-16
12	159106	1	SPRING
13	1928731	2	LOCKNUT, Hex, Jam, 3/8-16
14	1925359	2	SCREW, Taptite, 5/16-18 x 3/4
15	1665193	1	PIVOT, (All except 6000)
16	1921977	2	CAPSCREW, hex, 5/16-18 x 1-1/4
17	1920415	2	CAPSCREW, Hex, 3/8-16 x 1-1/4
18	1934653	1	SCREW, Whizlock, 3/8-16 x 3
19	1922755	1	WASHER, Plain, 13/32 x 1
20	1666294	1	SPACER
21	1666287	1	PULLEY ASSY., w/Bearing (Incl. Ref. Nos.22,23, 24)
22		1	PULLEY (Order Ref. No. 21)
23	927695	1	RING, Retaining
24	1705997	1	BEARING
25	1666191	1	STOP, Belt
26	1665199	1	PUSH BAR ASSY.
27	1666188	1	BRAKE BRACKET ASSY. (Incl. Ref. Nos. 28, 29, 30)
28	925160	1	RIVET
29	1665240	1	PAD, Brake
30	1665195	1	BRACKET, Brake
31	156306	6	PIN
32	1667820	1	STOP, Belt
33	1917421	1	NUT, Hex, Jam, 3/8-16
34	1669125	1	SUPPORT, Hitch, Rear (6000 Series only)

NOTE: Refer to page 12 for Winterizing Kits.

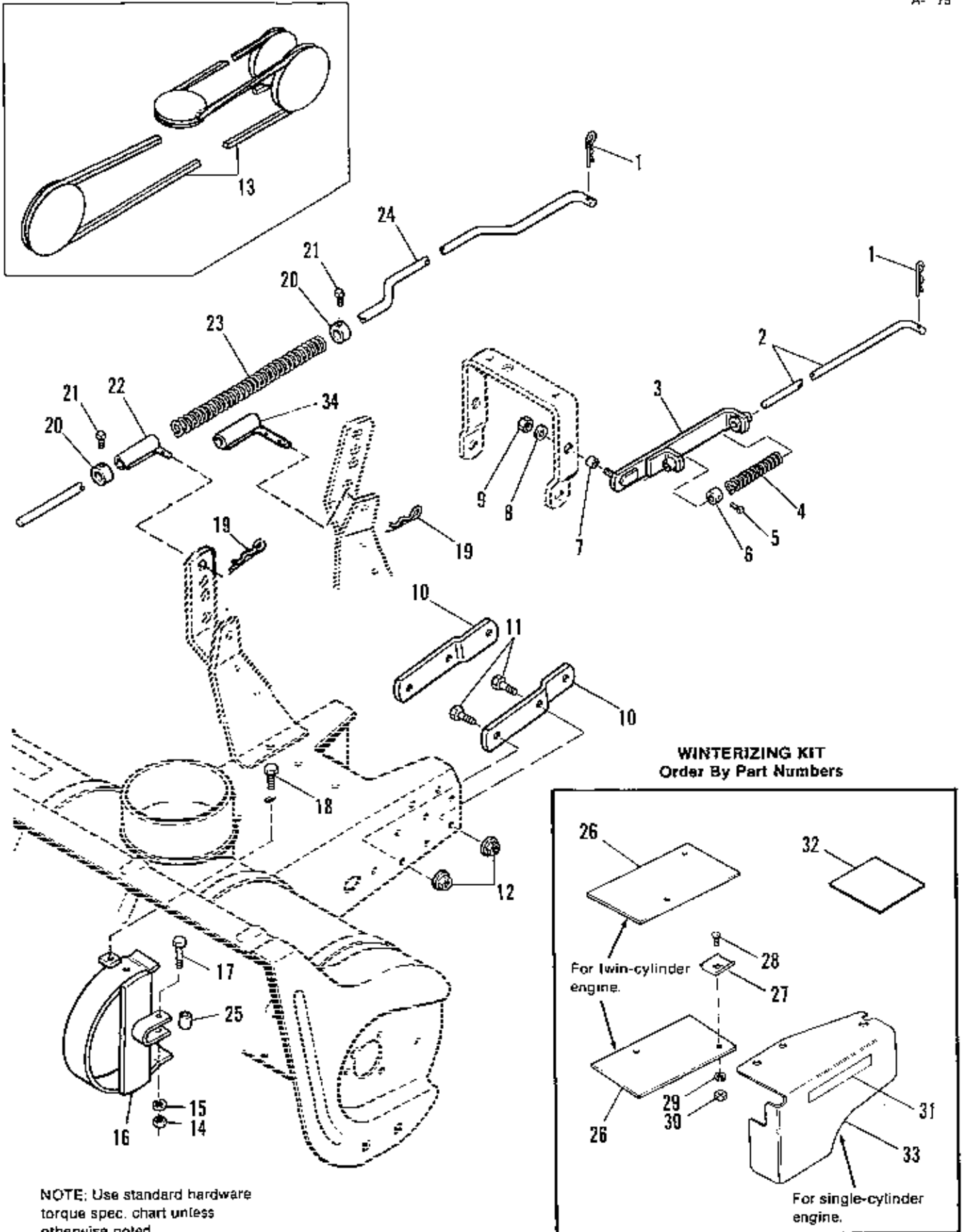

WINTERIZING KIT
Order By Part Numbers

NOTE: Use standard hardware torque spec. chart unless otherwise noted.

36" & 42" Misc. Hitch Group

Ref. No.	Part No.	Qty.	Description
1	106788	2	CLIP, Spring
2	1674193	1	ROD
3	1665194	1	GUIDE ASSY., Rod
4	163103	1	SPRING
5	1928804	1	SETSCREW, 1/4-20 x 3/8
6	8191022	1	COLLAR, Set
7	154177	1	SPACER
8	1917642	1	WASHER, Plain, 5/16
9	1928731	1	LOCKNUT, Hex, Jam, 3/8-16
10	177565	2	CLIP, Frame
11	1920676	4	CAPSCREW, Hex, 7/16-14 x 1
12	1930650	4	LOCKNUT, Hex, Flange, 7/16-14
13	1703466	1	V-BELT (Drive)
14	1917372	1	NUT, Hex, Full, 5/16-18
15	1917356	1	LOCKWASHER, 5/16
16	1668100	1	GUARD ASSY., Belt
17	1922127	1	CAPSCREW, Hex, 5/16-18 X 1-1/4
18	1924856	1	SCREW, Self-Tping, 5/16-18 x 1/2
19	106787	1	CLIP, Spring
20	8031007	2	COLLAR, Set
21	1928721	2	SETSCREW, 5/16-18 x 1/2
22	1709285	1	GUIDE ASSY., Rod, (1692239 only)
23	171011	1	SPRING
24	1665887	1	ROD, Lift
25	123027	1	SPACER
26	1666955	2	HOOD, w/louvers (for twin-cylinder engines)
27	1667831	4	CLIP
28	1923333	4	CARRIAGE BOLT, 1/4-20 X 5/8
29	1916964	4	LOCKWASHER
30	1916622	4	NUT, Hex, Full, 1/4-20
31	170252	1	DECAL, Shield
32	1667030	1	DECAL, Installation (under hood)
33	1651562	1	DEFLECTOR (for single-cylinder engines)
34	171679	1	GUIDE ASSY., (1690556 only)

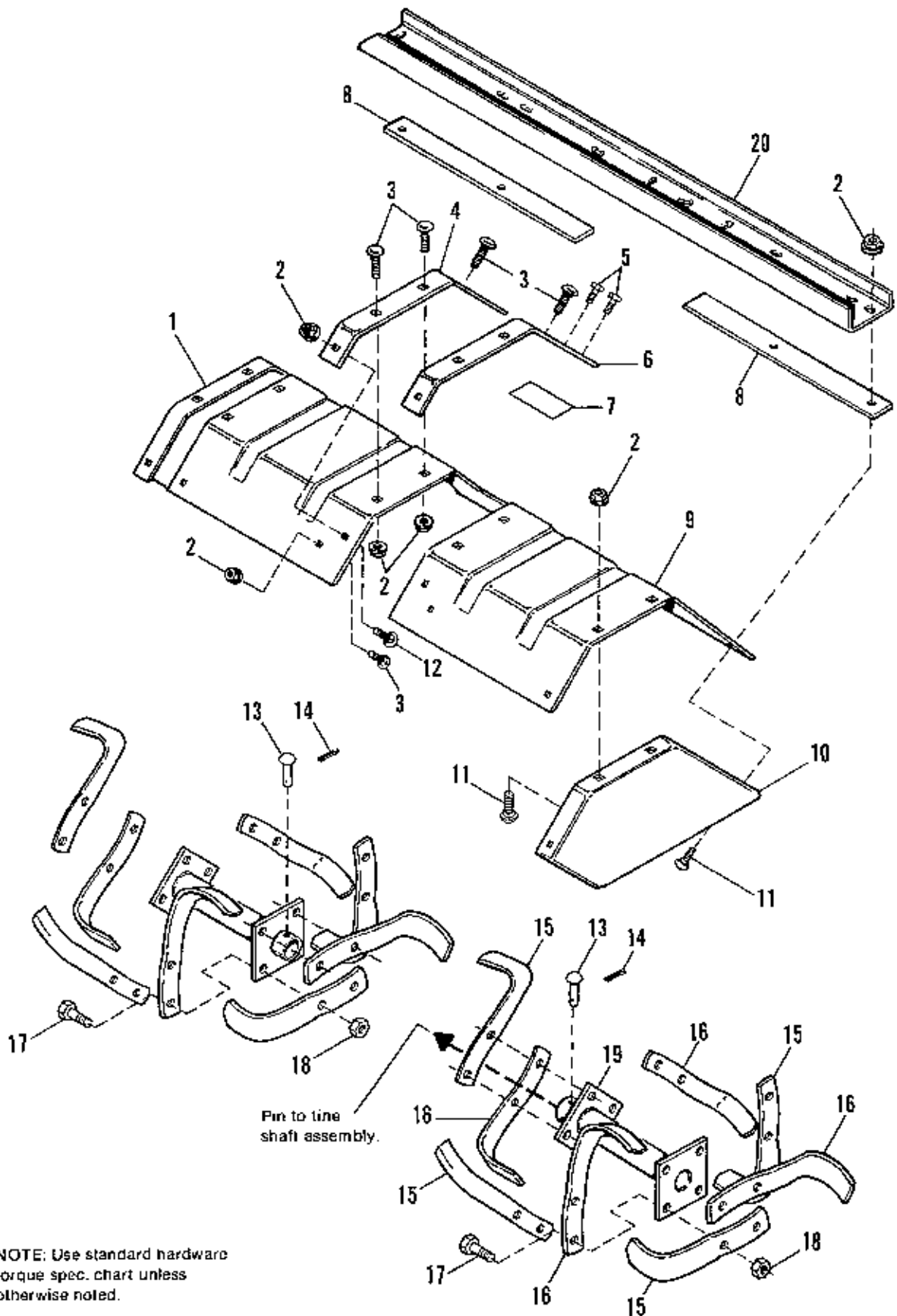

Pin to tine
shaft assembly.

NOTE: Use standard hardware
torque spec. chart unless
otherwise noted.

Deflector & Tine Group

Ref. No.	Part No.	Qty.	Description
1	105274	1	PLATE END, Deflector, R.H.
2	1927557	22	NUT, Hex, Flange, 5/16-18
3	1931332	14	CARRIAGE BOLT, 5/16-18 x 5/8
4	1656088	1	BAR, Reinforcement, R.H.
5	1664847	4	SCREW, Taplite, 5/16-18 x 3/4
6	1656087	1	BAR, Reinforcement, L.H.
7	1679700	2	DECAL, Safety
8	1701034	2	SPACER, Strip
9	1678768	1	DEFLECTOR
10	105273	1	PLATE END, Deflector, L.H.
11	1931333	6	CARRIAGE BOLT, 5/16-18 x 3/4
12	1931335	2	CARRIAGE BOLT, 5/16-18 x 1
13	118053	2	PIN
14	1918451	2	PIN, Cotter, 1/8 x 3/4
15	8152001	8	TINE BLADE, L.H.
16	8152002	8	TINE BLADE, R.H.
17	1922380	16	CAPSCREW, Hex, 7/16-20 x 1-1/4
18	1928867	16	LOCKNUT, Hex, 7/16-20
19	1656040	2	HUB & PLATE ASSY., Tine
20	1700700	1	CHANNEL

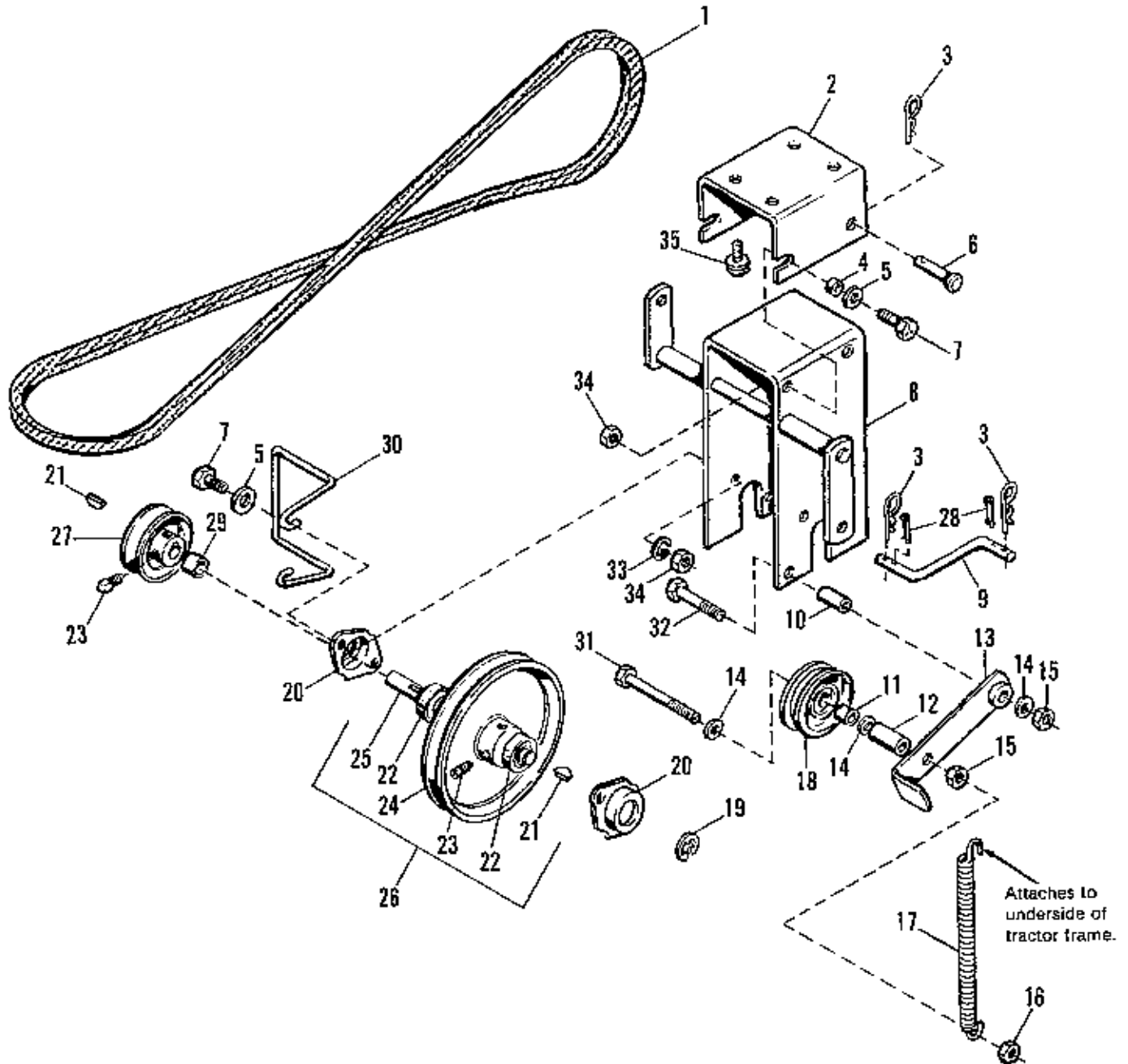

NOTE: Use standard hardware torque spec. chart unless otherwise noted.

Jackshaft Group

Ref. No.	Part No.	Qty.	Description
1	1700059	1	BELT, "V" Front
2	1679797	1	BRACKET, Jackshaft, Frame
3	1918196	4	PIN
4	1675481	2	SPACER
5	1924874	4	WASHER, Flat, 3/8 x 7/8 x 1/16
6	1960116	2	PIN, Rivet
7	1921333	6	BOLT, Hex Hd., 5/16-18 x 1
8	1679746	1	BRACKET ASSY., Jackshaft
9	1679745	1	LINK, Clutch
10	1663194	1	SPACER
11	1666294	1	SPACER
12	170389	1	SPACER
13	1679015	1	ARM, Idler Assy.
14	1922755	3	WASHER, Flat, 13/32 x 1 x 16
15	1916950	2	NUT, Hex, 3/8-16 Unc.
16	1930651	1	NUT, Hex, 3/8-16 Unc.
17	1666759	1	SPRING, Extension
18	1665434	1	PULLEY ASSY.
19	927793	1	"E" RING
20	1667341	1	RETAINER, Bearing
21	905123	2	KEY, Woodruff, #9, 5/16 x 3/4
22	1705897	2	BEARING
23	1930544	4	SETSCREW, 5/16-18 x 3/8
24	1679728	1	PULLEY ASSY.
25	1679723	1	SHAFT, Jack
26	1700313	1	SHAFT ASSY., Jack
27	1679727	1	PULLEY
28	1918447	2	COTTER PIN
29	1700258	1	SPACER
30	1700051	1	STOP, Belt
31	1923903	1	BOLT, Hex Hd., 3/8-18 Unc. x 3
32	1921974	1	BOLT, Hex Hd., 3/8-16 Unc. x 1-1/2
33	1917356	4	LOCKWASHER, 5/16
34	1917372	6	NUT, Hex, 5/16-18
35	1923683	4	SCREW, Hex, Washer Hd., Tapfit, 3/8-16 x 3/4

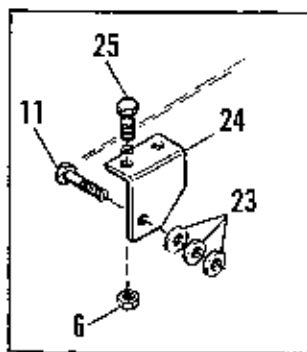

Early Model
Idler Bracket

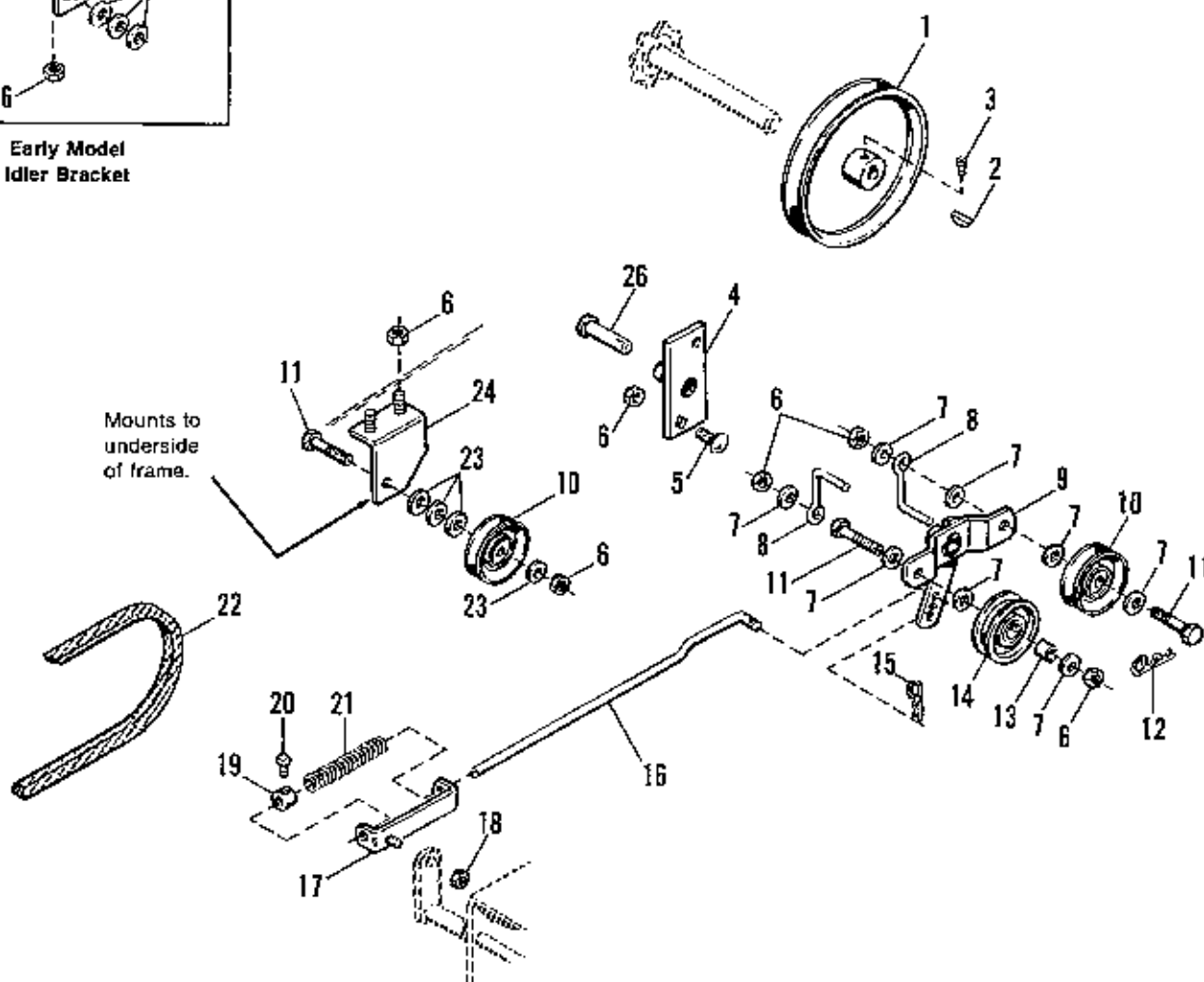

Mounts to
underside
of frame.

NOTE: Use standard hardware
torque spec. chart unless
otherwise noted.

Drive & Clutch Group

Ref. No.	Part No.	Qty.	Description
1	1679729	1	PULLEY, Driven
2	905123	1	KEY, #9, 3/16 x 3/4
3	1930544	2	SETSCREW, 5/16-18 x 1/2
4	1701367	1	BRACKET & HUB ASSY.
5	1931348	1	CARRIAGE BOLT, 3/8 x 3/4
6	1916950	6	NUT, 3/8-18
7	1922755	8	WASHER, 3/8 x 1 x 1/8
8	1656054	2	GUIDE, Belt
9	1679857	1	BRACKET ASSY., Idler
10	174561	2	PULLEY, Idler
11	1921971	3	CAPSCREW, 3/8-16 x 1-3/4
12	1960033	1	PIN, Quick, Hairpin
13	1666294	1	SPACER
14	1665434	1	PULLEY (Flat-side)
15	1918196	1	PIN
16	1679744	1	ROD, Clutch
17	108662	1	GUIDE, Rod
18	1923362	1	NUT, 5/16-18
19	8191022	1	COLLAR SET
20	1928804	1	SETSCREW, 1/4-20 x 3/8
21	163103	1	SPRING
22	1673667	1	BELT, "V" Rear
23	1917642	4	WASHER, 5/16
24	1700011	1	BRACKET, Idler (Early Models)
	1703726	1	BRACKET, Idler (Later Models)
25	923369	2	CAPSCREW, Hex, 3/8-16 x 3/4 (Later models only)
26	1701388	1	PIN, Clevis

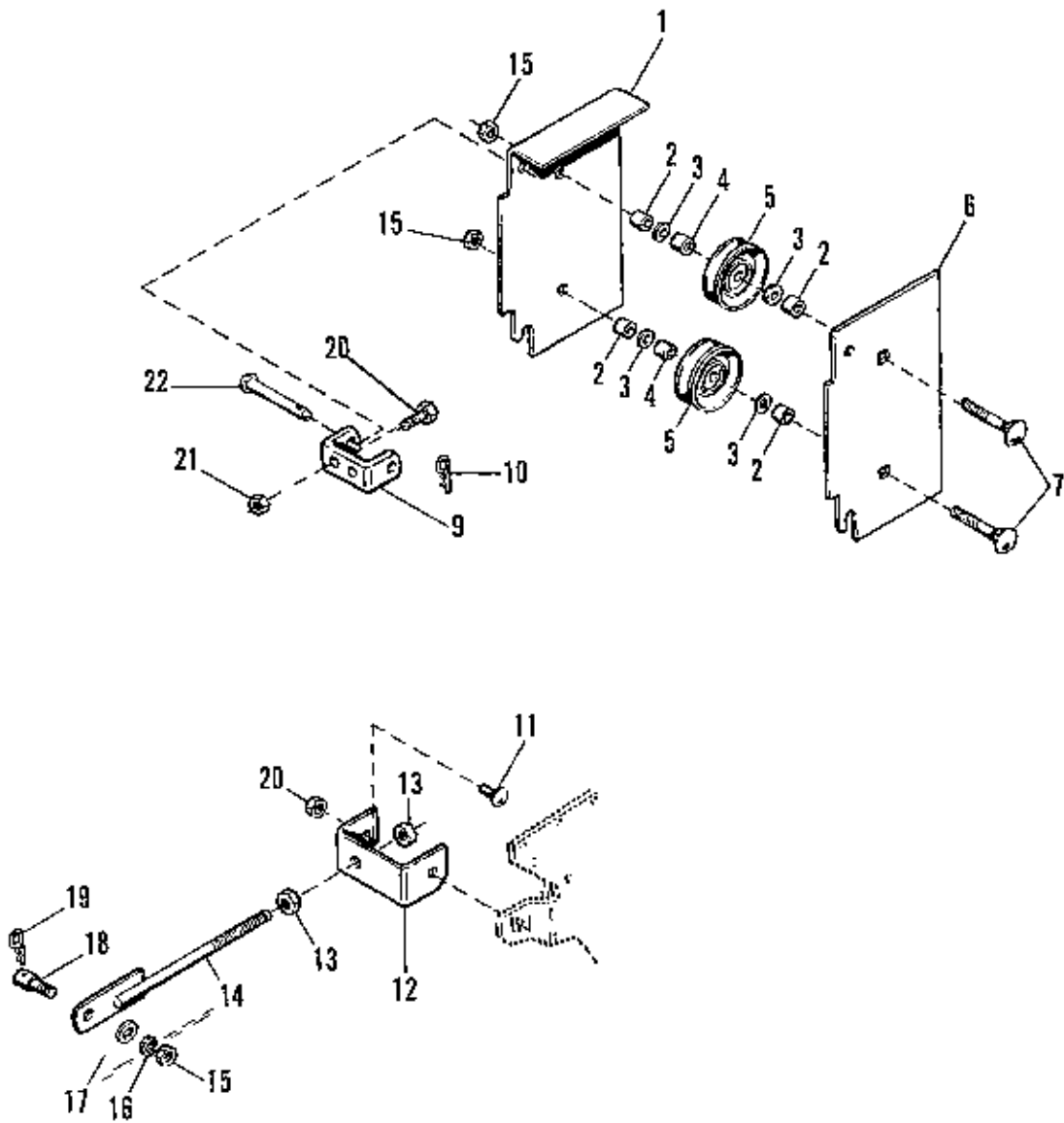

NOTE: Use standard hardware torque spec. chart unless otherwise noted.

Pulley Guard Group

Ref. No.	Part No.	Qty.	Description
1	1679725	1	GUARD, Pulley, R.H.
2	118335	4	SPACER
3	1817642	4	WASHER, Flat, 3/8 x 7/8 x 14
4	1666294	2	SPACER
5	1665434	2	PULLER ASSY.
6	1679726	1	GUARD, Pulley, L.H.
7	1931355	2	BOLT, 5/8 x 15 x 2-1/4
8	1923325	2	BOLT, Hex Hd., 5/16-18 x 7/8, Gr.5
9	1679722	1	BRACKET, Guard
10	1918196	1	PIN
11	1931348	2	CARRIAGE BOLT, 3/8 x 3/4
12	1679224	1	CLEVIS, Mast
13	1919262	2	NUT, Hex, Jam, 1/2-20
14	1679221	1	ARM, Mast Assy.
15	1916950	3	NUT, Hex, 3/8-16
16	1916965	1	LOCKWASHER, 3/8
17	1922755	1	WASHER, 3/8 x 1 x 1/8
18	1679226	1	PIN
19	1960033	1	PIN, Quick
20	1930651	2	NUT, Hex, 3/8-16
21	1917372	2	NUT, Hex, 5/16-18
22	1679721	1	PIN, Guard Bracket

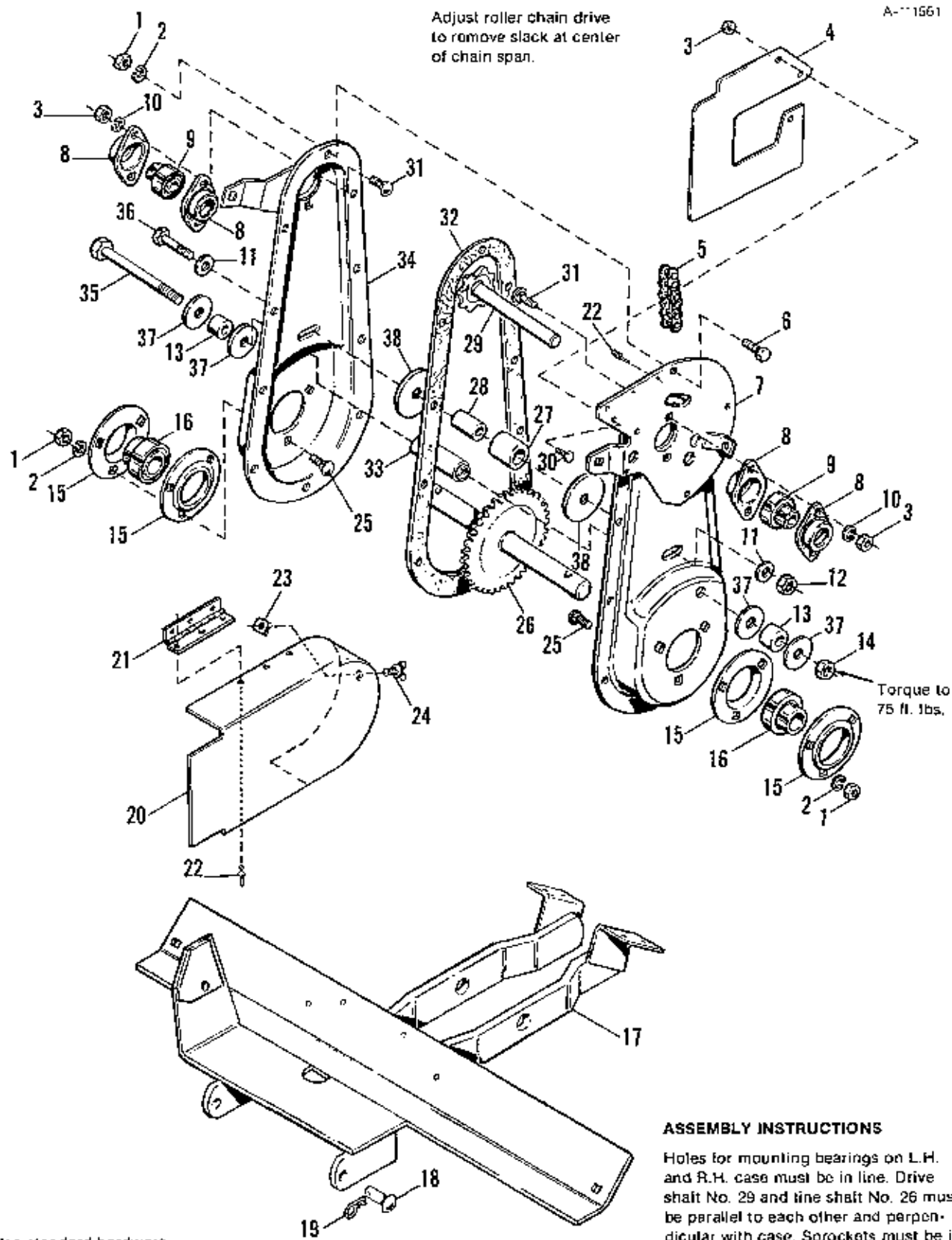

Case Group

Ref. No.	Part No.	Qty.	Description
1	1917372	16	NUT, Hex, Full, 5/16-18
2	1917356	16	LOCKWASHER, 5/16
3	1916622	7	NUT, Hex, Full 1/4-20
4	1700726	1	COVER, Guard
5	170053	1	CHAIN
6	1925205	10	CAPSCREW, Hex Hd., 5/16-18 x 5/8
7	1679289	1	CASE ASSY., Half, L.H.
8	1655814	4	BEARING
9	1656089	2	BEARING
10	1916964	4	WASHER, Lock, 1/4
11	157424	2	WASHER, Special
12	1930651	1	NUT, Hex Hd., Full, Lock, 3/8-16
13	105386	2	SPACER
14	1922134	1	NUT, Hex Hd., Full, Lock, 1/2-13
15	172278	4	FLANGE, Bearing
16	173934	2	BEARING
17	1676770	1	FRAME & HITCH ASSY.
18	155037	2	PIN
19	1960033	2	CLIP, Hairpin
20	1700723	1	GUARD, Belt
21	1701320	1	HINGE
22	1673450	6	RIVET, Pop
23	918118	1	NUT, "U" Type
24	1935023	1	SCREW, Wing
25	1931333	6	CARRIAGE BOLT, 5/16-18 x 3/4
26	170090	1	SHAFT ASSY., Tine
27	170177	1	ROLLER
28	170369	1	SPACER
29	1655827	1	SHAFT ASSY., Drive
30	1921958	3	CAPSCREW, Hex Hd., 1/4-20 x 1/2
31	1931317	4	CARRIAGE BOLT, 1/4-20 x 3/4
32	170022	1	GASKET, Case
33	170029	1	SPACER, Case
34	1679288	1	CASE ASSY., Half R.H.
35	1926159	1	CAPSCREW, Hex Hd., 1/2-13 x 5
36	1922130	1	CAPSCREW, Hex Hd., 3/8-16 x 2-1/4
37	960154	4	WASHER
38	960188	2	WASHER

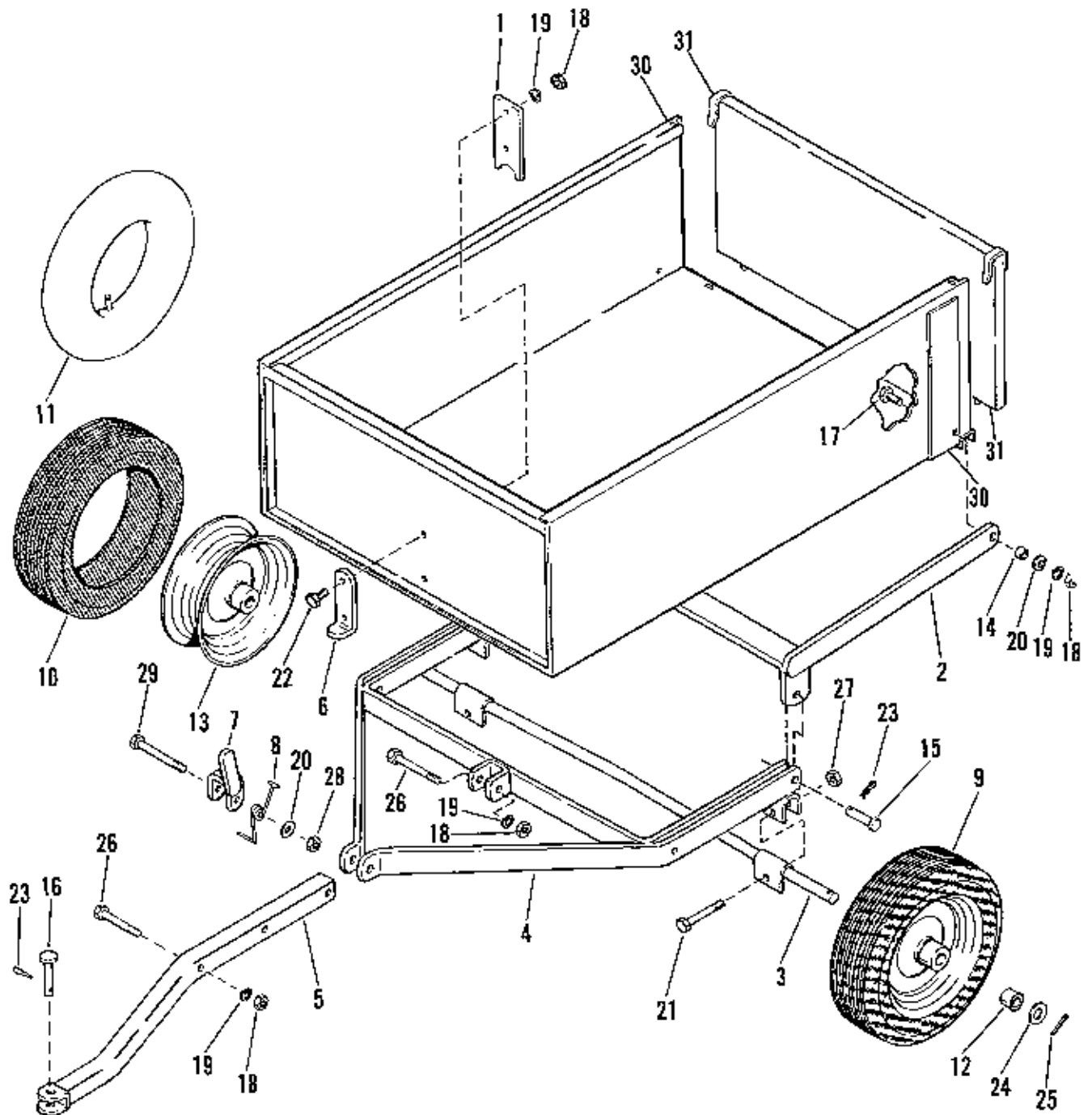

NOTE: Use standard hardware torque spec. chart unless otherwise noted.

Dump Cart Group

Ref. No.	Part No.	Qty.	Description
1	102005	1	PLATE, Box Guide
2	102024	1	PIVOT ASSY., Box
3	102027	1	AXLE ASSY.
4	102035	1	FRAME ASSY.
5	102037	1	TONGUE ASSY.
6	102040	1	PLATE, Box Catch
7	102051	1	CLEVIS ASSY.
8	102075	1	SPRING, Torsion
9	170320	2	WHEEL & TIRE ASSY. (Incl. Ref. Nos.10,11,12,13)
10	102052	2	TIRE
11	153038	2	TUBE, 4.00 x 8
12	156316	4	BEARING
13	170319	2	WHEEL
14	8151076	2	BUSHING
15	102004	2	PIN, Pivot
16	105249	1	PIN
17	921210	2	CAPSCREW, Hex, 3/8-16 x 1
18	916950	6	NUT, Hex, Full, 3/8-16
19	916965	6	LOCKWASHER, 3/8
20	917378	3	WASHER, 3/8
21	921978	2	CAPSCREW, 5/16-18 x 2
22	920415	2	CAPSCREW, Hex, 3/8-16 x 1-1/4
23	918196	3	PIN, Quick
24	918433	2	WASHER, Plain, 3/4
25	918459	2	PIN, Cotter, 3/16 x 1-1/2
26	922130	2	CAPSCREW, Hex, 3/8-16 x 2-14
27	923362	2	NUT, Hex, Full, 5/16-18
28	930651	1	NUT, Hex, Centerlock, 3/8-16
29	930596	1	CAPSCREW, Hex, 3/8-16 x 2-3/4
30	1668478	1	TRAILER & END GATE ASSY.
31	1668462	1	GATE END

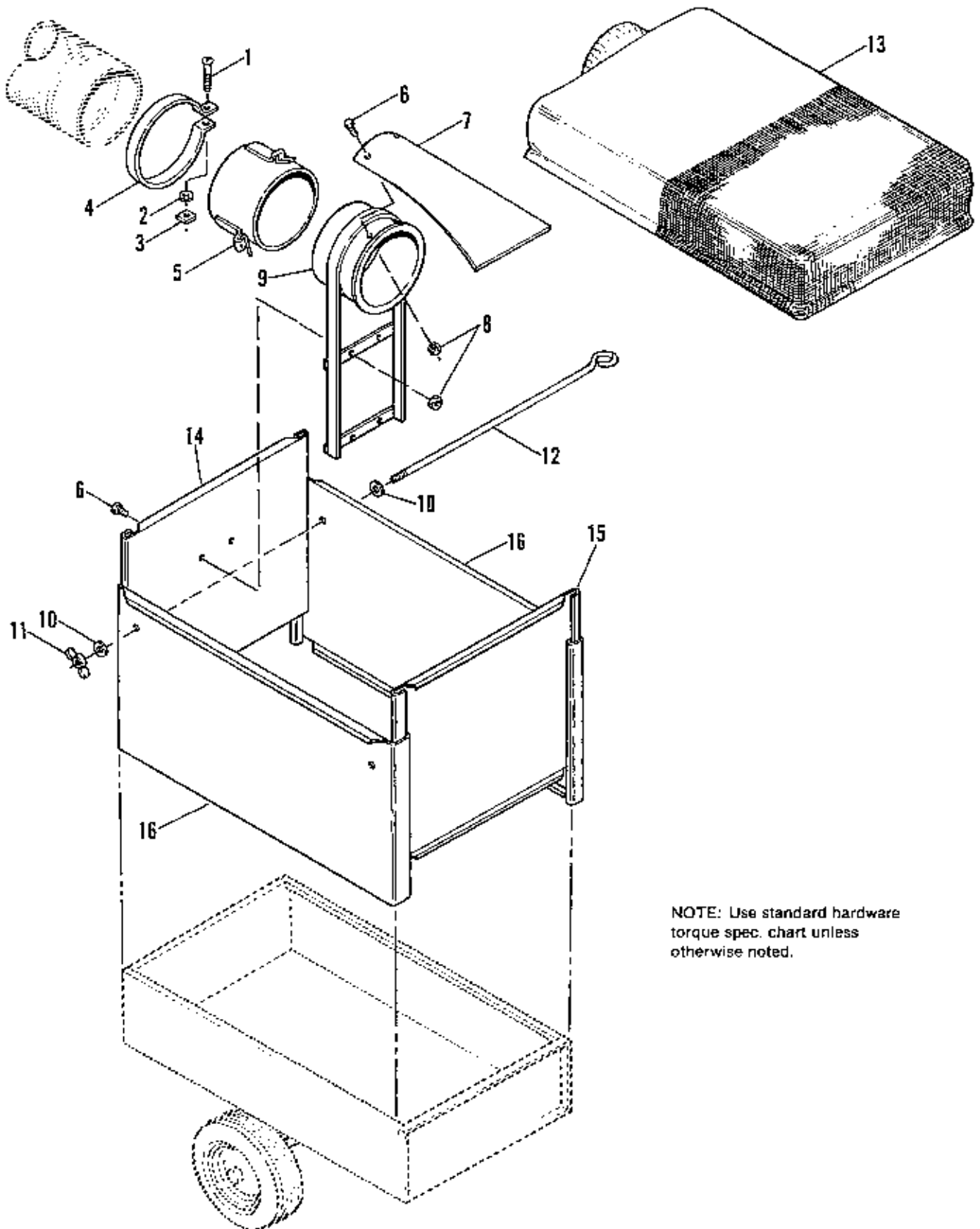

NOTE: Use standard hardware torque spec. chart unless otherwise noted.

Cart Cover & Side Extension Group

Ref. No.	Part No.	Qty.	Description
1	1928866	1	SCREW, Rd. Hd., 1/4-20 x 3
2	1916964	1	LOCKWASHER, 1/4
3	1916622	1	NUT, Hex, 1/4-20
4	123067	1	CLAMP, Hose
5	1665782	1	CONNECTOR, Hose, 6"
6	1921959	4	CAPSCREW, Hex Hd., 1/4-20 x 5/8
7	1665781	1	DEFLECTOR
8	1923358	4	LOCKNUT, Hex, 1/4-20
9	1665780	1	CONNECTOR, Metal, 6"
10	1917377	4	WASHER
11	1916952	2	WINGNUT, 1/4-20
12	1665778	2	ROD, 27"
13	1665779	1	BONNET
14	1665777	1	PANEL, Front
15	1665776	1	PANEL, Rear
16	1665775	2	PANEL, Side

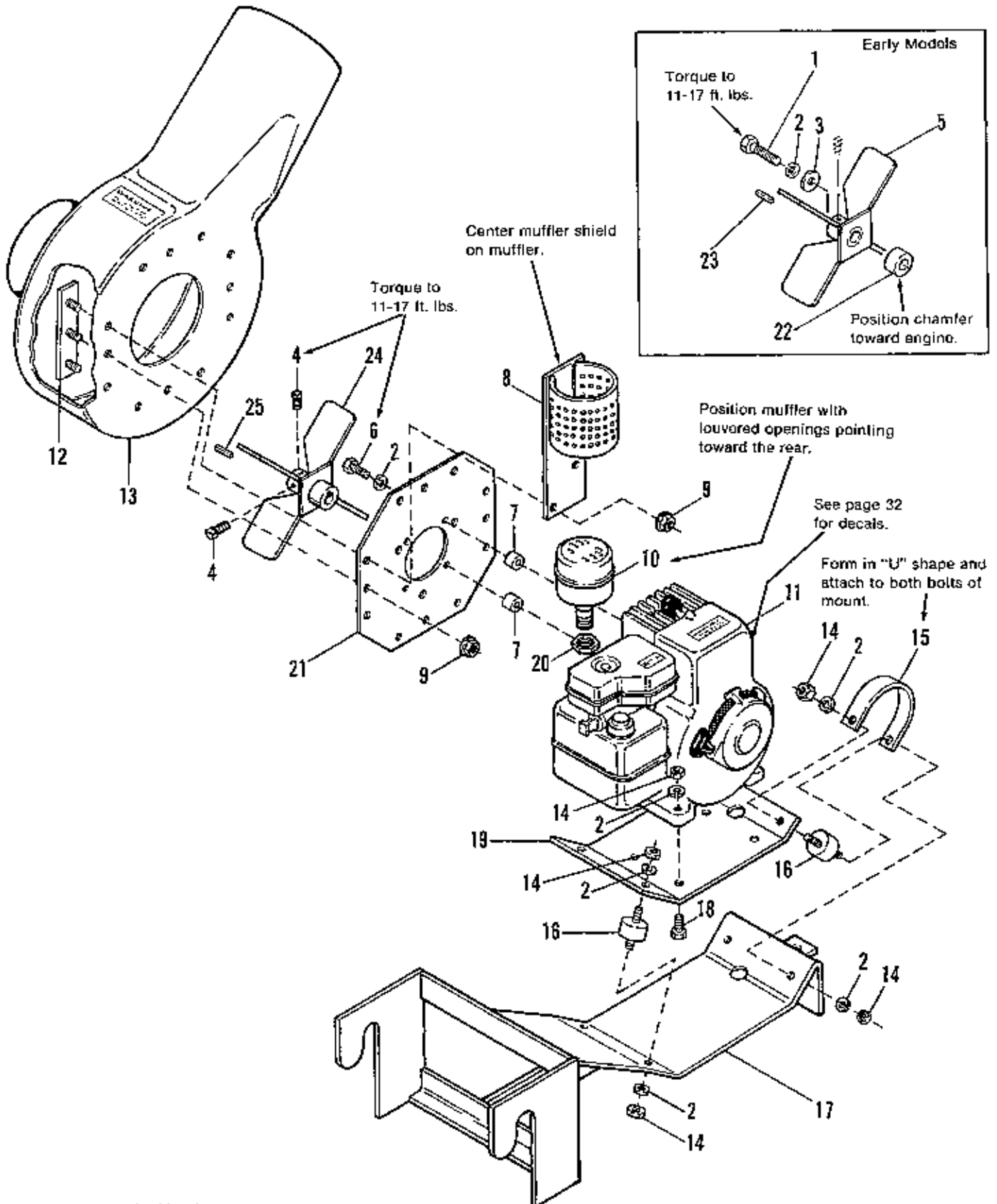

NOTE: Use standard hardware torque spec. chart unless otherwise noted.

Vacuum Collector Housing & Engine Group

Ref. No.	Part No.	Qty.	Description
1	*927927	1	CAPSCREW, Hex Hd., 5/16-24 x 1/2
2	*917356	16	LOCKWASHER, 5/16 (Qty. 17 used before s/n 2890)
3	*1933468	1	WASHER
4	1928721	2	SETSCREW, 5/16-18 x 1/2
*5		1	FAN ASSY.
6	1921982	4	CAPSCREW, Hex Hd., 5/16-24 x 1-1/4
7	157081	4	SPACER
8	1672133	1	SHIELD ASSY., Muffler
9	1927557	12	LOCKNUT, Hex, Flange, 5/16-18
10	1657505	1	MUFFLER
11		1	ENGINE, Briggs & Stratton, 4 HP
12	1657456	4	BAR ASSY.
13	1702472	1	HOUSING
14	1917372	12	NUT, Hex, Full, 5/16-18
15	1657460	1	STRAP, Ground
16	159085	4	CONNECTOR
17	1656968	1	FRAME ASSY.
18	1921221	4	CAPSCREW, Hex Hd., 5/16-18 x 1-1/2
19	123095	1	PLATE, Engine
20	1932650	1	LOCKNUT, 1/2
21	1656972	1	PLATE, Housing Support
22	*1654907	1	SPACER
23	*905850	1	KEY, 3/16 x 3/16 x 1
24	**1671658	1	FAN ASSY., 3/16 x 3/16 x 1-7/8 (Incl. Ref. Nos. 4 & 25)
25	**1672129	1	KEY

* Used on models with serial no. 2890 and before. (See "Early Models" drawing on page 28. If replacement fan is required, see Ref. No. 24 to update to new design.

** Used on models with serial no. 2891 and later.

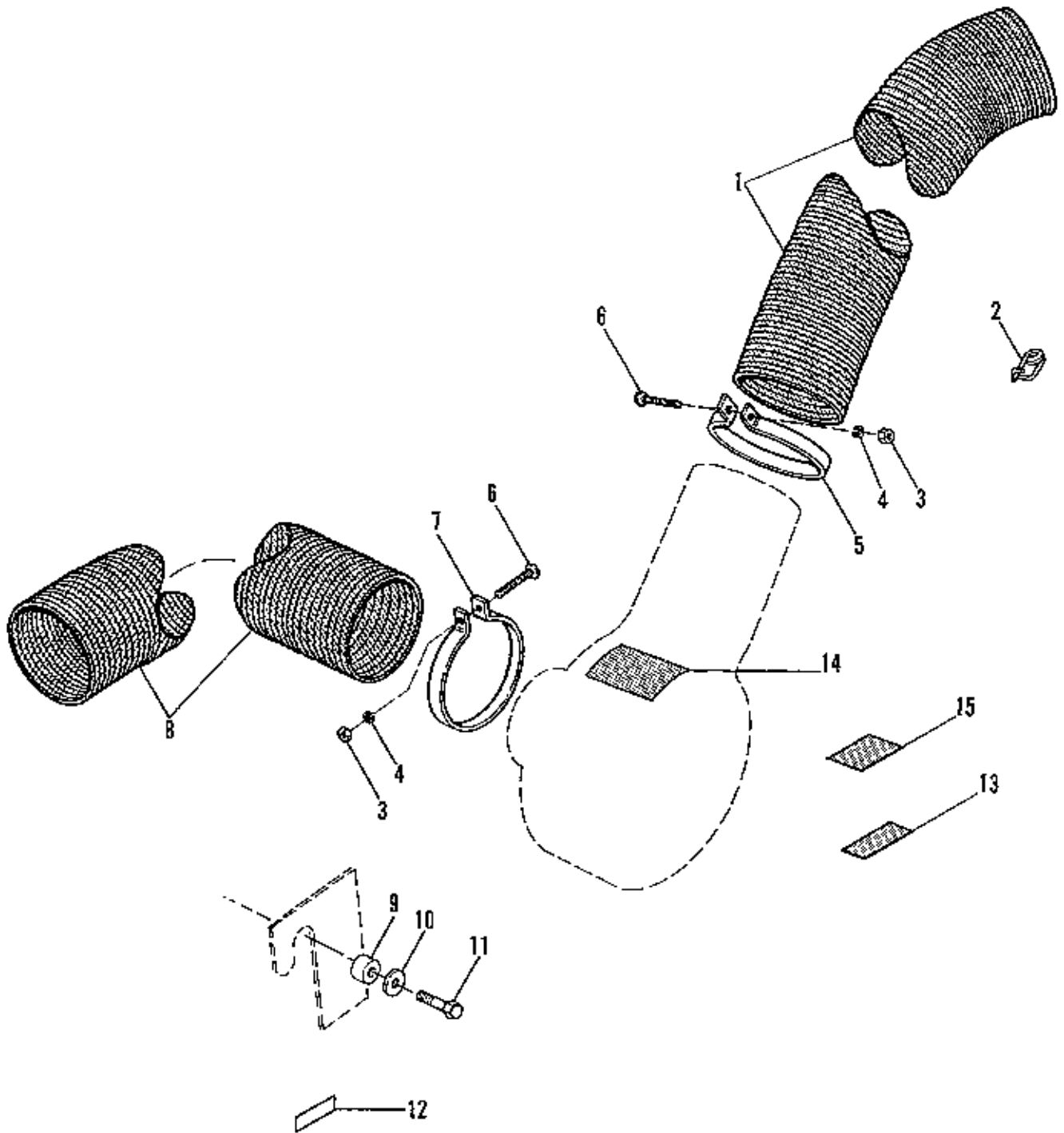

NOTE: Use standard hardware torque spec. chart unless otherwise noted.

Vacuum Collector Misc. Group

Ref. No.	Part No.	Qty.	Description
1	1669967	1	HOSE ASSY., Outlet, 6" Dia.
2	176012	1	CLIP, Pin, Safety
3	1916622	2	NUT, Hex, 1/4-20
4	1916964	2	LOCKWASHER, Spring, 1/4
5	123067	1	CLAMP, Hose, 6"
6	1928866	2	SCREW, Rd. Hd., 1/4-20 x 3
7	123065	1	CLAMP, Hose, 7"
8	1657189	1	HOSE ASSY., Inlet, 7" Dia.
9	158227	2	SPACER
10	1917378	2	WASHER, Plain, 3/8
11	1920415	2	CAPSCREW, Hex Hd., 3/8-16 x 1-1/4
12		1	PLATE, I.D.
13	1657137	1	DECAL, Throttle
14	1657149	1	DECAL, Warning
15	1657931	1	DECAL, Muffler

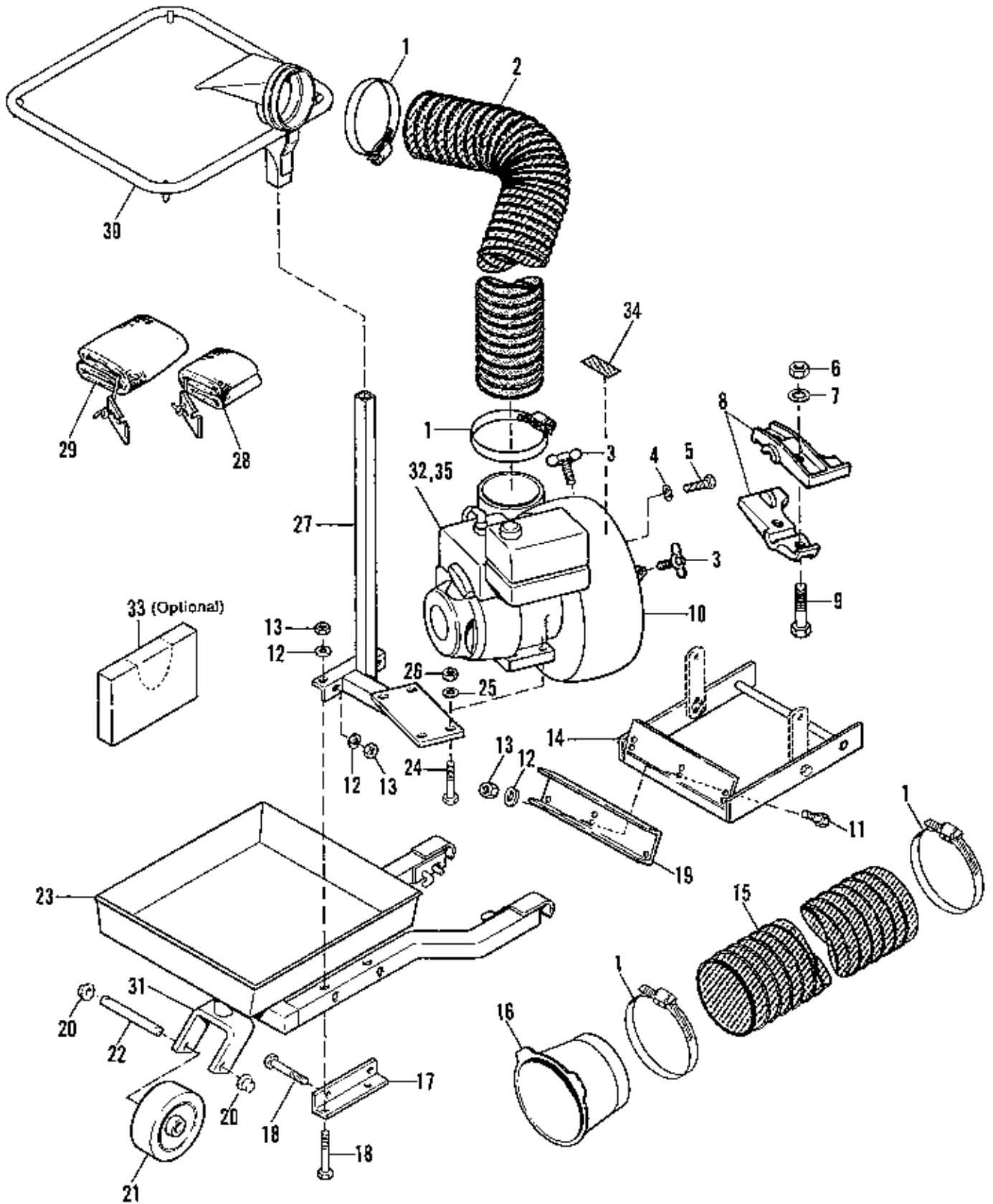

Engine Driven Vacuum Collector (Single Wheel Model)

Ref. No.	Part No.	Qty.	Description
1	921919	4	CLAMP, Hose
2	1667641	1	HOSE, Flexible
3	1667317	2	BOLT, Wing, 5/16-18 x 2
4	1923300	4	LOCKWASHER, Int. Tooth, 5/16
5	1921515	4	CAPSCREW, Hex Hd. 5/16-24 x 3/4
6	1916951	2	NUT, Hex, Full, 1/2-13
7	1909589	2	LOCKWASHER, Int. Tooth, 1/2
8	1665665	1	BLADES, Blower (Pair)
9	1920328	2	CAPSCREW, Hex Hd., 1/2-13 x 1-1/2
10	1667639	1	HOUSING, Blower
11	1921210	3	LOCKWASHER, 3/8
12	1917378	7	WASHER, Plain, 3/8
13	1916950	7	NUT, Hex, Full, 3/8-18
14	1667631	1	HITCH ASSY.
15	1667646	1	HOSE, Lower
16	1667647	1	CONE, 7"
17	1667637	1	ANGLE, Reinforcing
18	1921972	4	CAPSCREW, Hex Hd., 3/8-16 x 2-1/2
19	1668405	1	CLAMP, Mount
20	1678563	2	PUSH NUT
21	1705342	1	WHEEL, Caster
22	1705341	1	AXLE, Caster
23	1678014	1	TRAY & SUPPORT ASSY.
24	1921221	4	CAPSCREW, Hex Hd. 5/16-18 x 1-1/2
25	1917358	4	LOCKWASHER, 5/16
26	1917372	4	NUT, Hex, Full, 5/16-18
27	1667636	1	ENGINE MOUNT & UPRIGHT
28	1667644	1	TOP, Canvas Bag
29	1667643	1	BAG, Canvas
30	1667638	1	RING, Bag Support
31	1705343	1	FORK ASSY., Caster
32		1	ENGINE, 4 H.P., Briggs & Stratton
33	1685595	1	LINERS, Plastic Bag (Pkg. of 18)
34		1	DECAL, Warning (Not serviced)
*35	123104	1	MUFFLER

*Ref. No. 35 only used on models with serial numbers from 1101-1121 Model 100212 engine.

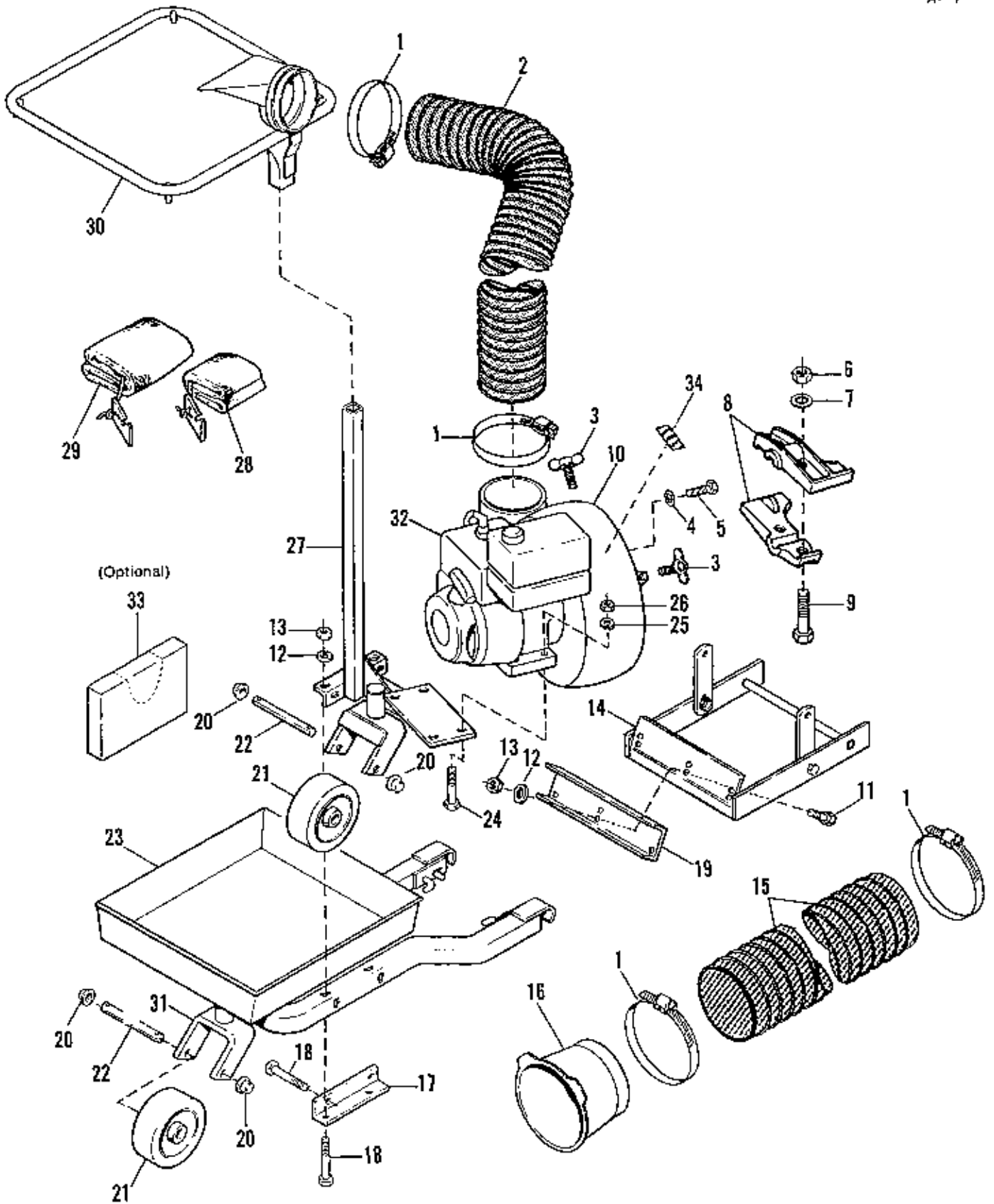

Engine Driven Vacuum Collector (Two Wheel Model)

Ref. No.	Part No.	Qty.	Description
1	921919	4	CLAMP, Hose
2	16676	1	HOSE, Flexible
3	1667317	2	BOLT, Wing, 5/16-18 x 2
4	1923300	4	LOCKWASHER, Int., 5/16
5	1921515	4	CAPSCREW, Hex Hd., 5/16-24 x 3/4
6	1916951	2	NUT, Hex, Full, 1/2-13
7	1909589	2	LOCKWASHER, Int., 1/2
8	1665665	1	BLADES, Blower (Pair)
9	1920328	2	CAPSCREW, Hex Hd., 1/2-13 x 1-1/2
10	1667639	1	HOUSING, Blower
11	1921210	3	CAPSCREW, Hex Hd., 3/8-16 x 1
12	1917378	7	LOCKWASHER, 3/8
13	1916950	7	NUT, Hex, Full 3/8-16
14	1667631	1	HITCH ASSY.
15	1667646	1	HOSE, Lower
16	1667647	1	CONE, 7"
17	1667637	1	ANGLE, Reinforcing
18	1921972	4	CAPSCREW, Hex Hd., 3/8-16 x 2-1/2
19	1668405	1	CLAMP, Mount
20	1678563	4	PUSH NUT
21	1667633	2	WHEEL, Caster
22	1667634	2	AXLE, Caster
23	1678014	1	TRAY & SUPPORT ASSY.
24	1921221	4	CAPSCREW, Hex Hd., 5/16-18 x 1-1/2
25	1917356	4	LOCKWASHER, 5/16
26	1917372	4	NUT, Hex, Full, 5/16-18
27	1878015	1	ENGINE MOUNT & UPRIGHT
28	1667644	1	TOP, Canvas Bag
29	1667643	1	BAG, Canvas
30	1667638	1	RING, Bag Support
31	1705343	1	FORK ASSY., Caster
32		1	ENGINE, 4 H.P., Briggs & Stratton
33	1685595	1	LINERS, Plastic Bag (pkg of 18)
34		1	DECAL, Warning (Not Serviced)

NOTE: Use standard hardware torque spec. chart unless otherwise noted.

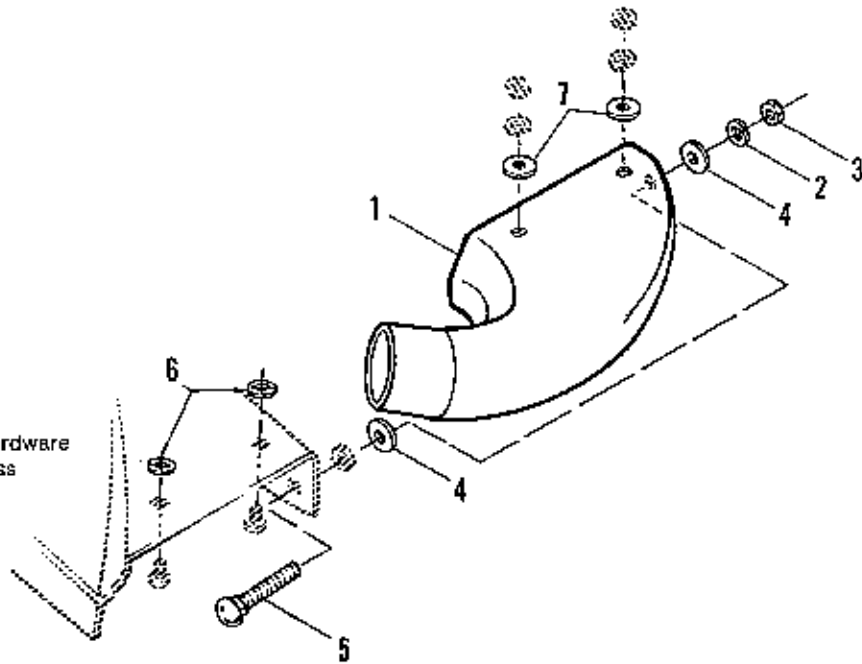

NOTE: Use standard hardware torque spec. chart unless otherwise noted.

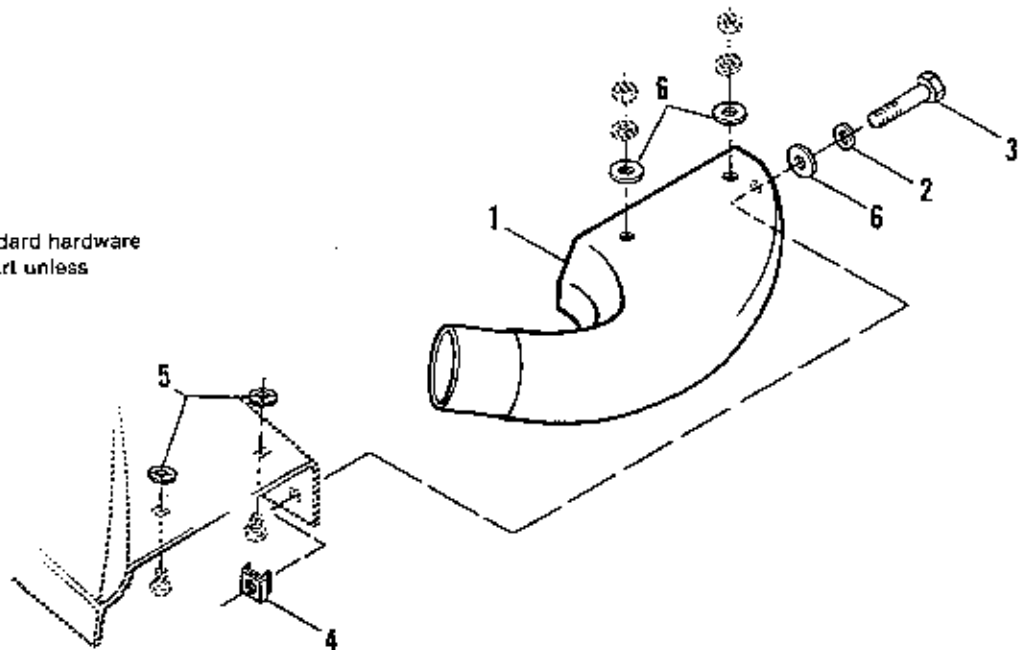

Mfg. No. 1690227

42" & 48" Vacuum Collector Adaptor

Ref. No.	Part No.	Qty.	Description
1	1657007	1	ADAPTOR, 42" & 48" Mowers
2	1917356	1	LOCKWASHER, Spring, 5/16
3	1917372	1	NUT, Hex, 5/16-18
4	1917642	2	WASHER, Plain, 5/16
5	1920564	1	BOLT, Carriage, 5/16-18 x 1-1/4
6	1931942	2	PUSHNUT, 3/8
7	1924356	2	WASHER

Mfg. No. 1690228

36" Vacuum Collector Adaptor

Ref. No.	Part No.	Qty.	Description
1	165788	1	ADAPTOR, 36" Mower
2	1917356	1	LOCKWASHER, Spring, 5/16
3	1923325	1	CAPSCREW, Hex, 5/16-18 x 7/8
4	930659	1	NUT, Retainer, 5/16-18
5	1931942	2	PUSHNUT, 3/8
6	1924356	3	WASHER

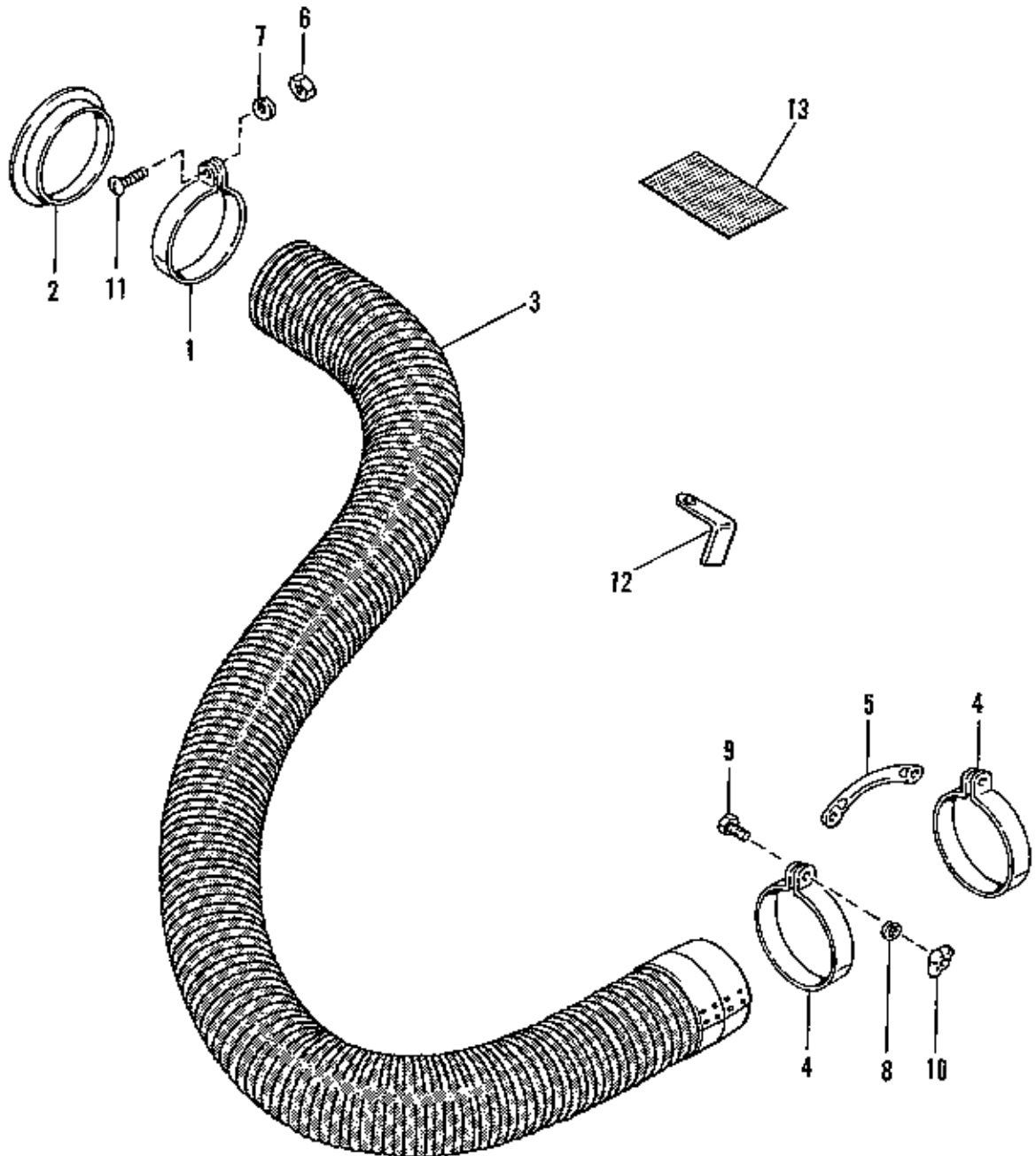

NOTE: Use standard hardware
torque spec. chart unless
otherwise noted.

Roving Nozzle Group

Ref. No.	Part No.	Qty.	Description
1	123065	1	CLAMP, Hose
2	123111	1	FLANGE, Hose
3	123127	1	HOSE ASSY.
4	123128	2	CLAMP, Hose
5	123129	1	HANDLE, Hose
6	1916622	1	NUT, Hex, 1/4-20
7	1916964	1	LOCKWASHER, Spring, 1/4
8	1917356	2	LOCKWASHER, Spring, 5/16
9	1921332	2	CAPSCREW, Hex Hd., 5/16-18 x 3/4
10	1918468	2	NUT, Wing, 5/16-18
11	928866	1	SCREW, Rd. Hd., 1/4-20 x 3
12	*1664122	1	STOP, Belt
13	1668683	1	DECAL, Warning

*Not used in all applications

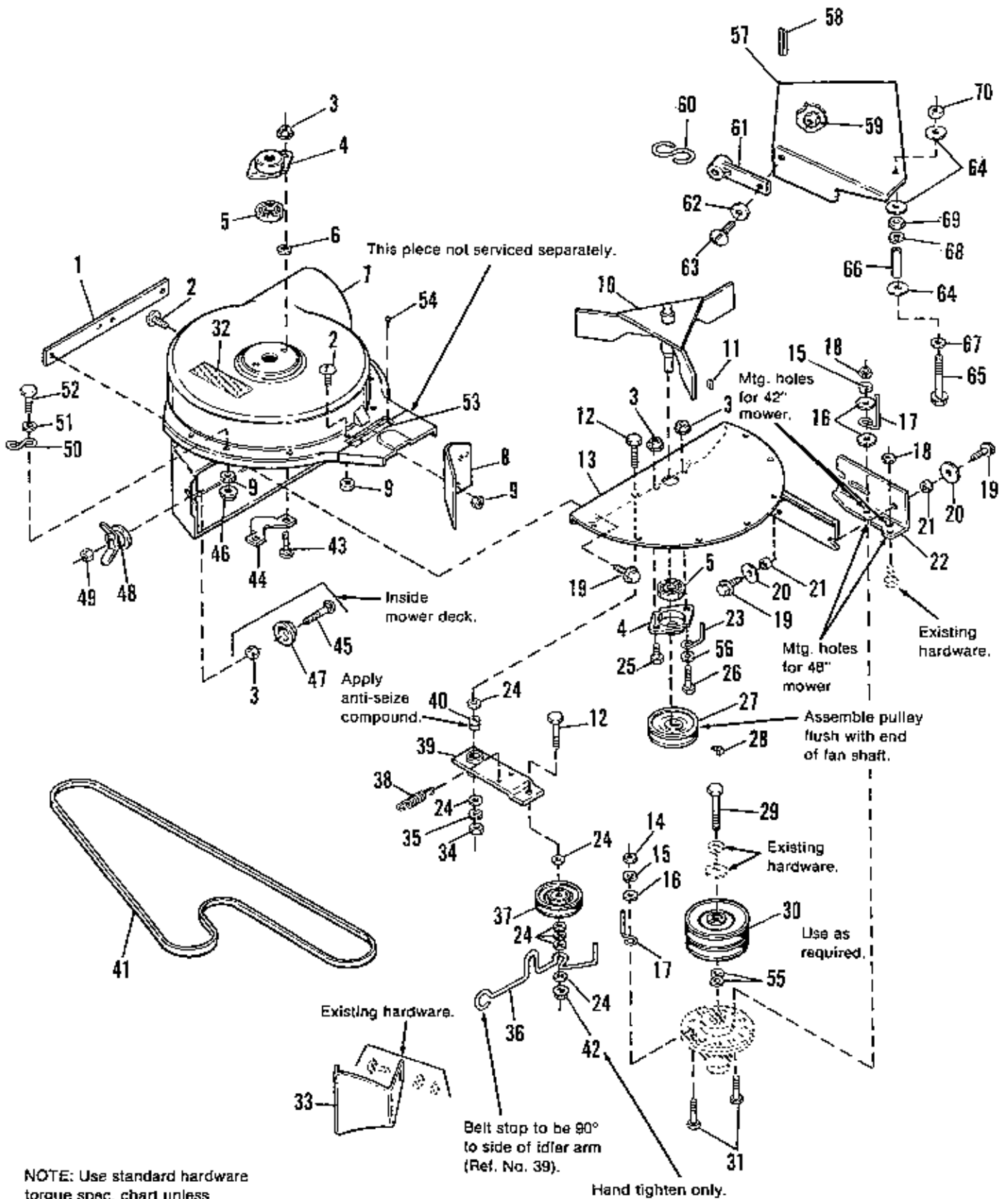

NOTE: Use standard hardware torque spec. chart unless otherwise noted.

Turbo Blower System (42" & 48" Mowers)

Ref. No.	Part No.	Qty.	Description
1	1678946	1	STRAP, Reinforcement, Blower Housing
2	1921959	7	CAPSCREW, Hex Hd., 1/4-20 x 5/8
3	1927557	4	NUT, Flange Lock, 5/16-18
4	1667341	2	BEARING, Retainer
5	1705897	2	BEARING
6	933988	4	PUSHNUT, 5/16
7	1700231	1	FAN HOUSING & HINGE ASSY. (Inc. Ref. Nos. 32, 53 & 54)
8	1678994	1	BAFFLE, Fan Housing
9	1930641	8	NUT, Hex, Nylon Lock, 1/4-20
10	1678601	1	FAN ASSY.
11	918312	1	KEY, Woodruff #61, 3/16 x 5/8
12	1921971	2	CAPSCREW, Hex, 3/8-16 x 1-3/4
13	1678705	1	PLATE ASSY.
14	1917372	1	NUT, Hex, Full 5/16-18
15	1917356	2	LOCKWASHER, 5/16
16	1919361	3	WASHER, Plain
17	1679105	2	STOP, Belt
18	1928698	2	NUT, Hex Jam Lock, 5/16-18
19	1927429	5	SCREW, Tapite, 1/4-20 x 5/8
20	1960151	2	WASHER, 1/4
21	1675339	2	SPACER
22	1678676	1	BRACKET, Arbor
23	1678924	1	STOP, Belt
24	1924940	7	WASHER, Plain, 13/32
25	1920787	1	CAPSCREW, Hex, 5/16-18 x 1/2
26	1960104	1	CAPSCREW, Hex, 5/16-18 x 3/4
27	1702685	1	PULLEY, Driven
28	1928691	1	SETSCREW, Sq. Hd., 5/16-18 x 5/8
29	1927120	1	CAPSCREW, Hex, 7/16-14 x 2-1/4
30	1678609	1	PULLEY ASSY.
31	1933689	2	CAPSCREW, Hex, 5/16-18 x 1-1/2
32	1700259	1	DECAL, Danger, Blower
33	1678646	1	BAFFLE, Discharge
34	1916950	1	NUT, Hex, Full, 3/8-16

Ref. Nos. 35-70 found on pages 42 & 43.

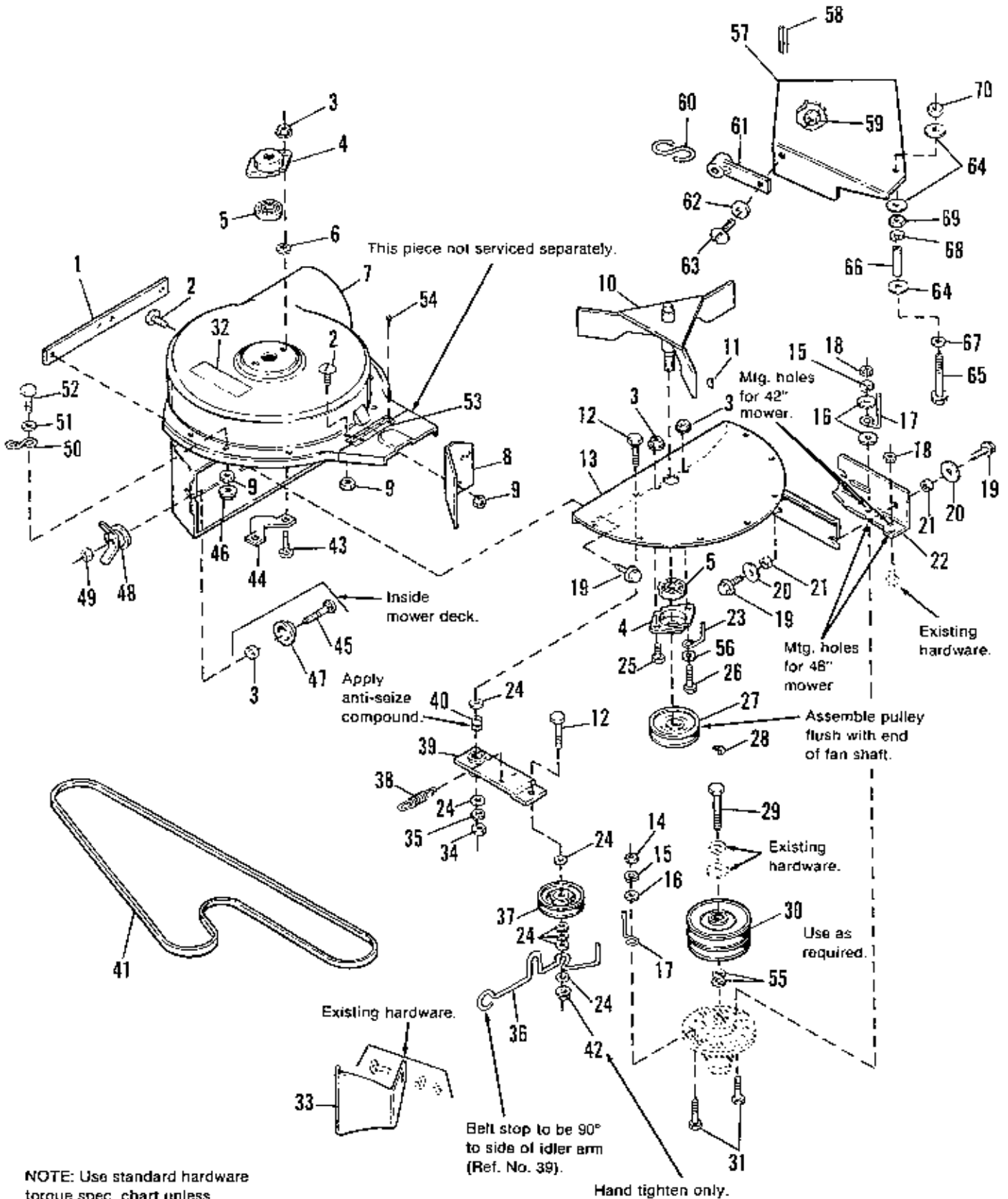

NOTE: Use standard hardware torque spec. chart unless otherwise noted.

Turbo Blower System (42" & 48" Mowers)

Ref. No.	Part No.	Qty.	Description
35	1916965	1	LOCKWASHER, 3/8
36	1701095	1	STOP, Belt
37	1708029	1	PULLEY, Idler
38	1679554	1	SPRING, Tension
39	1700861	1	IDLER ARM ASSY.
40	1666114	1	SPACER
41	1700415	1	BELT, Turbo
42	1930645	1	NUT, Hex, Flange Lock, 3/8-16
43	1931333	2	CARRIAGE BOLT, 5/16-18 x 3/4
44	1678811	1	PLATE, Flange, Blower Housing
45	1960273	1	CARRIAGE BOLT, 5/16-18 x 2-1/4
46	1930642	1	NUT, Flange Lock, 1/4-20
47	1679164	1	CUP
48	1679163	1	NUT ASSY., Wing
49	1923362	2	NUT, Hex, Full, Lock, 5/16-18
50	1672689	1	"S" HOOK
51	1921319	1	WASHER, Plain, 9/32
52	1921961	1	CAPSCREW, Hex Hd., 1/4-20 x 1-1/4
53	1679207	1	HINGE
54	1673450	6	RIVET, Pop
55	1960114	2	WASHER (As Required)
56	1919326	1	WASHER, 11/32
57	1704960	1	COVER ASSY., Pulley
*58	1679165	1	MOLDING
*59	1930627	1	NUT, Hex, Full Lock, #10-32
*60	1679204	1	"S" HOOK
*61	1679205	1	STRAP
*62	1960096	1	WASHER, Special
*63	1930531	1	SCREW, Truss, #10-32 x 1/2
*64	1920283	3	WASHER, Special
*65	1960272	1	CAPSCREW, Hex, 5/16-18 x 5-1/2
*66	1679085	1	SPACER
*67	1919381	1	WASHER, 5/16
*68	1917356	1	LOCKWASHER, 5/16
*69	1917372	1	NUT, Hex, Full, 5/16-18
*70	1923362	1	NUT, Hex, Full, Lock, 5/16-18

*Used on Mfg. No. 1691810 only.

Ref. Nos. 1 - 34 found on pages 40 & 41.

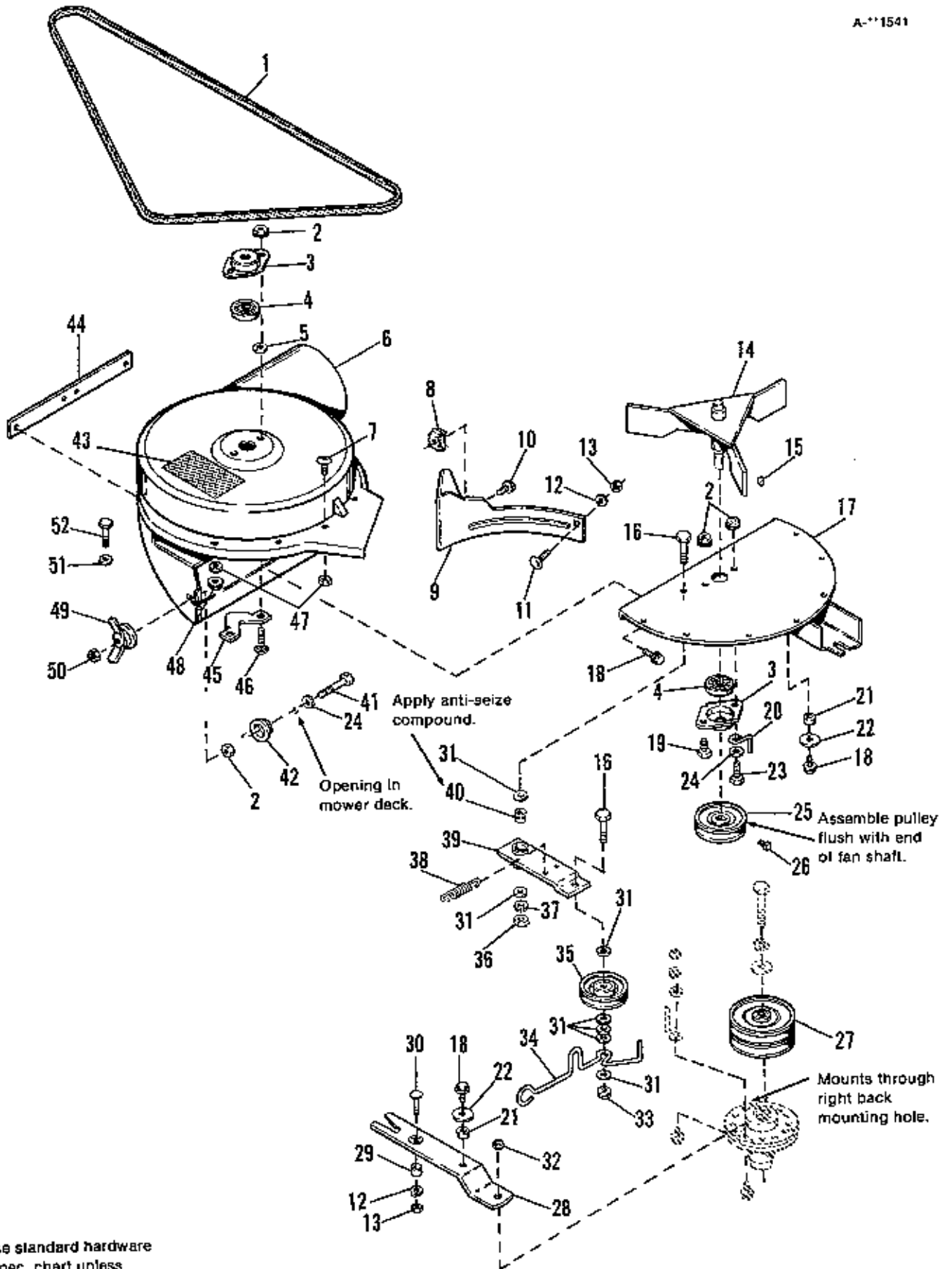

Note: Use standard hardware torque spec. chart unless otherwise noted.

Turbo Collector Blower for 36" Mowers - 4000 Series

Ref. No.	Part No.	Qty.	Description
1	1679915	1	BELT
2	1927557	4	NUT, Flange Lock, 5/16-18
3	1667341	2	BEARING, Retainer
4	1705899	2	BEARING
5	933988	4	PUSHNUT, 5/16
6	1700965	1	HOUSING ASSY., (Incl. Ref. No. 53)
7	1921959	6	SCREW, Truss Hd., 1/4-20 x 5/8
8	920462	1	NUT, Retainer, 1/4-20
9	1672171	1	BAFFLE
10	1931646	1	SCREW, Whizlock 1/4-20 x 1/2
11	1960252	1	CARRIAGE BOLT, 1/4-20 x 5/8
12	1916964	2	LOCKWASHER, 1/4
13	1916622	2	NUT, Hex Full, 1/4-20
14	1678601	1	FAN ASSY.
15	918312	1	KEY, Woodruff
16	1921971	2	CAPSCREW, 3/8-16 x 1-3/4
17	1700696	1	PLATE ASSY.
18	1927429	5	SCREW, Taplite, 1/4-20 x 5/8
19	1920787	1	CAPSCREW, Hex Hd., 5/16-18 x 1/2
20	1678924	1	STOP, Belt
21	1675339	2	SPACER
22	1960151	2	WASHER, Special
23	1960104	1	CAPSCREW, Hex Thin Hd., 5/16-18 x 3/4
24	1919326	2	WASHER, Plain, 11/32
25	1702685	1	PULLEY, Driven
26	1928691	1	SETSCREW, 5/16-18 x 1/2
27	1700705	1	PULLEY ASSY.
28	1700694	1	STRAP
29	1700695	1	SPACER
30	1931320	1	CARRIAGE BOLT, 1/4-20 x 1-1/4
31	1924940	7	WASHER, Plain 13/32
32	1928698	1	NUT, Hex Jam Lock, 5/16-18
33	1930645	1	NUT, Hex Flange Lock, 3/8
34	1701085	1	LEVER, Belt, Retainer
35	1708029	1	PULLEY, Idler
36	1916950	1	NUT, Hex Full, 3/8-16
37	1916965	1	LOCKWASHER, 3/8
38	1679554	1	SPRING, Tension
39	1700861	1	IDLER ARM ASSY.
40	1666114	1	SPACER
41	1960318	1	CAPSCREW, Hex, 5/16-18 x 2-1/2
42	1679164	1	CUP
43	1700259	1	DECAL, Danger
44	1678946	1	STRIP, Reinforcement
45	1678811	1	PLATE, Flange
46	1931333	2	CARRIAGE BOLT, 5/16-18 x 3/4
47	1930641	7	NUT, Hex, Lock, Nylon, 1/4-20
48	1930642	1	NUT, Hex, Flange Lock, 1/4-20
49	1679163	1	NUT ASSY.
50	1923362	1	NUT, Hex, Full, Lock, 5/16-18
51	1921319	1	WASHER, Plain, 1/4
52	1921960	1	CAPSCREW, Hex, 1/4-20 x 1

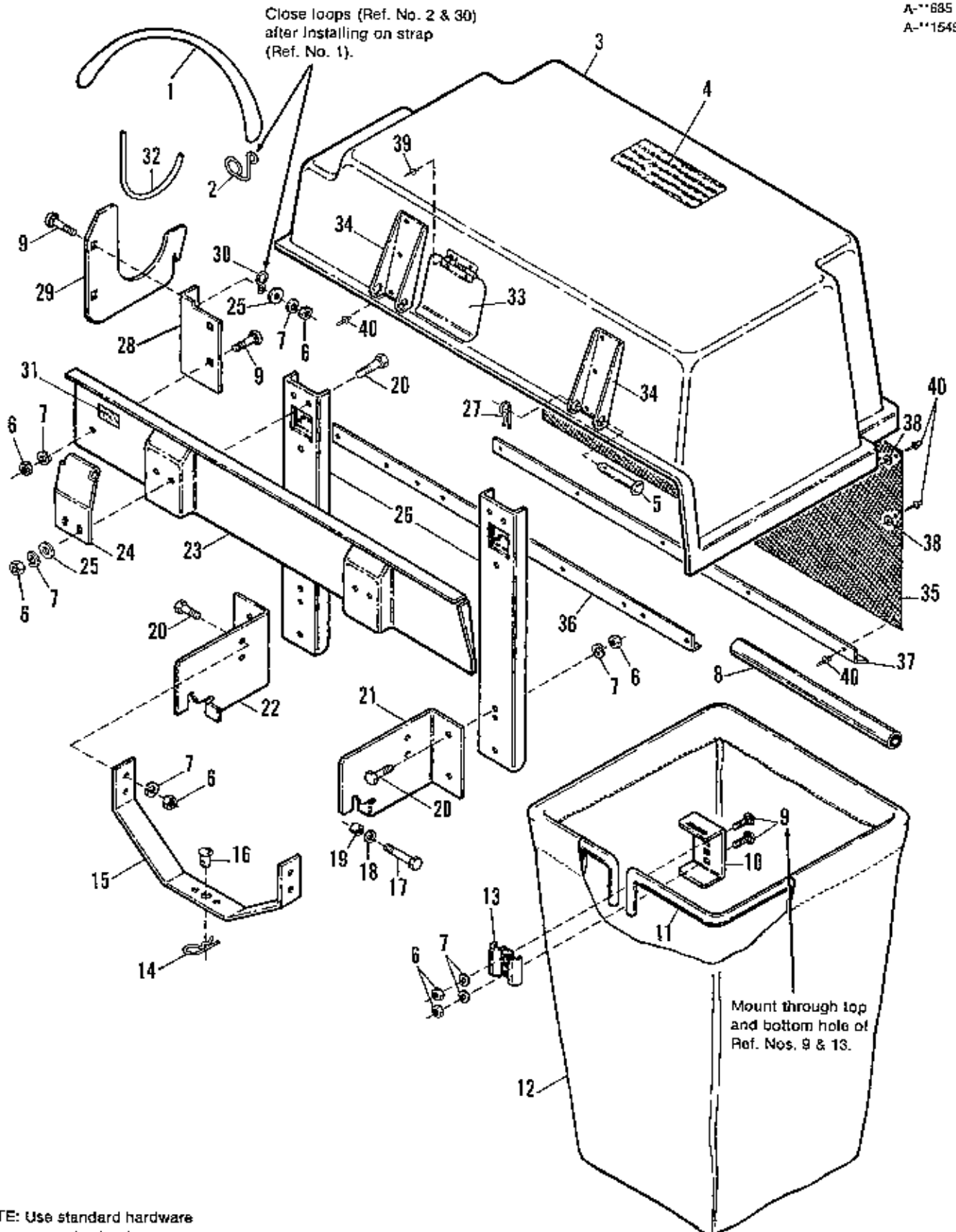

NOTE: Use standard hardware torque spec. chart unless otherwise noted.

Grass Catcher - Cover, Bag & Support Group

Ref. No.	Part No.	Qty.	Description
1	1665872	1	STRAP
2	1672888	1	HOOK, Strap
3	1675293	1	COVER ASSY. (Incl. Ref. Nos. 4, 33 & 34)
4	1676923	1	DECAL, Warning
5	1672344	2	PIN
6	1917372	20	NUT, Hex, 5/16-18
7	1917356	20	LOCKWASHER, 5/16
8	1675707	2	TUBE
9	1931334	8	BOLT, Carriage, 5/16-18 x 7/8 (Qty. 8 Deluxe only)
10	1672333	2	HANGER
11	1673602	2	HOOP, Bag
12	1672346	2	BAG, Grass
13	1672023	2	CLAMP
14	106788	1	CLIP, Hairpin
15	1672328	1	BRACE, Lower
16	1672365	1	PIN, Pivot
17	1920415	2	CAPSCREW, Hex, 3/8-16 x 1-1/4
18	1917378	2	WASHER, 3/8
19	158227	2	SPACER
20	1923325	12	CAPSCREW, Hex, 5/16-18 x 7/8
21	1672330	1	SUPPORT, L.H.
22	1672331	1	SUPPORT, R.H.
23	1672341	1	PLATE, Support, Cover
24	1672345	2	PLATE, Hinge
25	1917642	5	WASHER, 3/8 x 7/8
26	1672329	2	BRACE, Upper
27	106787	2	CLIP, Hairpin
28	1672325	1	MOUNT, Saddle Bracket
29	1672335	1	BRACKET, Saddle Assy.
30	1672689	1	"S" HOOK
31	1676924	1	DECAL
32	1673874	1	TRIM
33	1673201	1	DOOR & HINGE
34	1672324	2	HINGE, Bracket
35	1672340	1	SCREEN
36	1672323	1	BRACKET, Front Cover
37	1672322	1	BRACKET, Rear Cover
38	910531	4	WASHER, Rivet
39	1673450	2	RIVET, Pop
40	1673320	32	RIVET, Pop

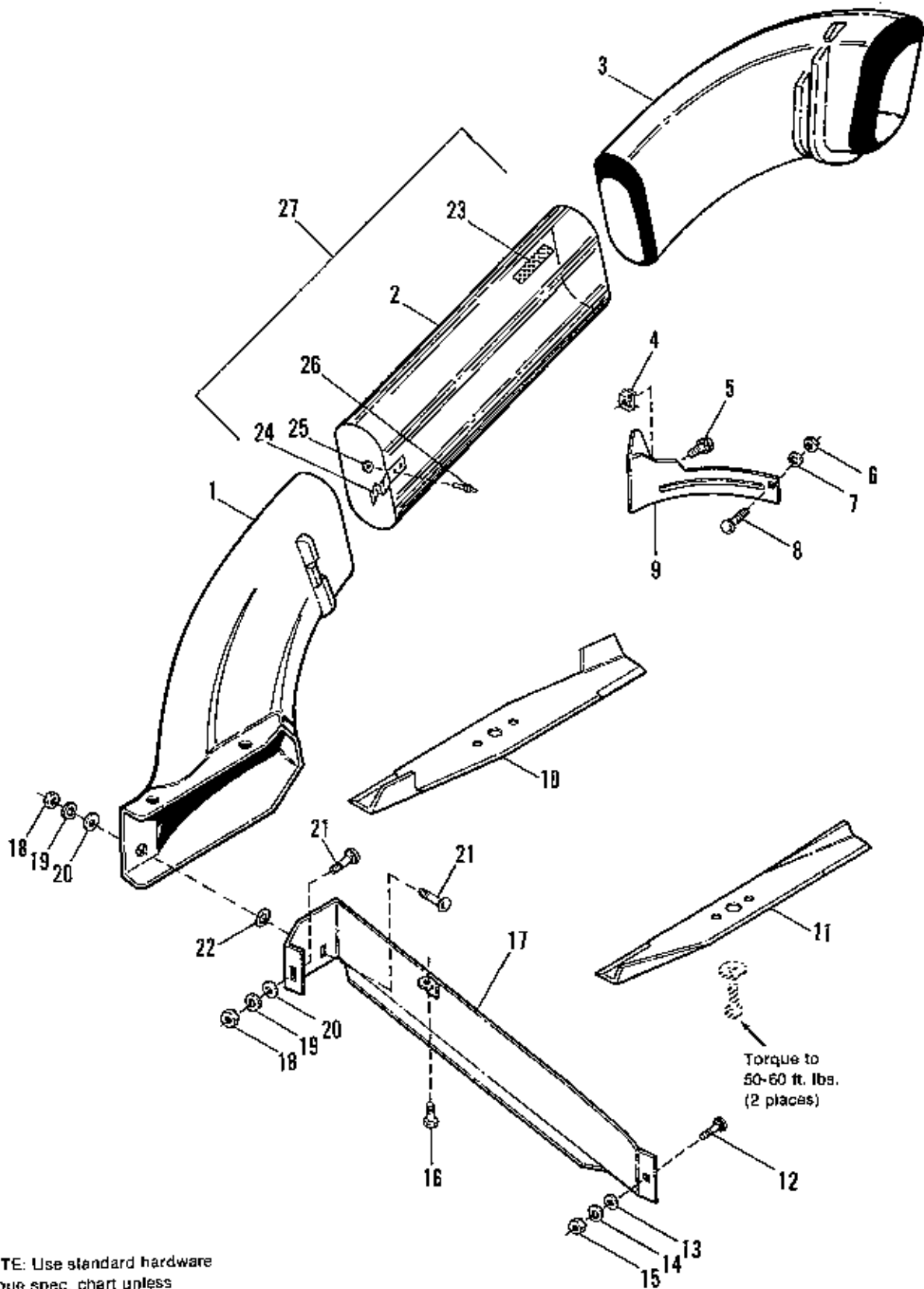

NOTE: Use standard hardware torque spec. chart unless otherwise noted.

Deluxe Grass Catcher - Tube & Blade Group

Ref. No.	Part No.	Qty.	Description
1	1669029	1	ADAPTOR
2		1	TUBE (Not Serviced Separately) (See Ref. No. 27)
3	1669793	1	ELBOW
4	920462	1	NUT, Retainer, 1/4-20
5	1931646	1	SCREW, Whizlock, 1/4-20 x 1/2
6	1916622	1	NUT, Hex, 1/4-20
7	1916964	1	LOCKWASHER, 1/4
8	1923333	1	BOLT, Carriage, 1/4-20 x 5/8
9	1672171	1	BAFFLE, Deflector Side
10	1671565	1	BLADE, R.H.
11	1671593	1	BLADE, L.H.
12	1931334	1	BOLT, Carriage, 5/16-18 x 7/8
13	1917377	1	WASHER, 1/4
14	1917356	1	LOCKWASHER, 5/16
15	1917372	1	NUT, Hex, 5/16-18
16	1924856	1	SCREW, Tapitite, 5/16-18 x 1/2
17	1656053	1	BAFFLE ASSY., Discharge
18	1916950	2	NUT, Hex, 3/8-16
19	1916965	2	LOCKWASHER, 3/8
20	1917378	4	WASHER, 3/8
21	1931348	3	BOLT, Carriage, 3/8-16 x 3/4
22	931942	3	NUT, Push-On
23	1675766	1	DECAL, Cleaning Instructions
24	1673757	1	SPRING, Retaining Tube
25	1910531	2	WASHER, Rivet
26	928706	2	RIVET, Tubulat
27	1673682	1	TUBE ASSY. (Incl. Ref. Nos. 2, 23, 24, 25 & 26)

Assembled View

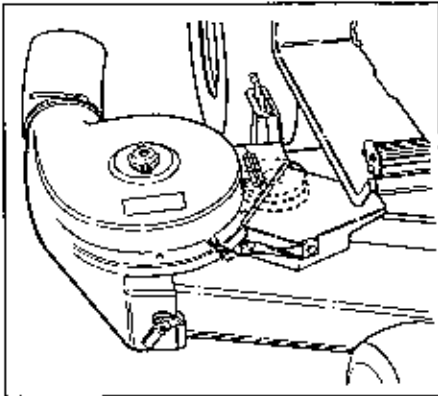

A-1514

42" & 48" Turbo Shown

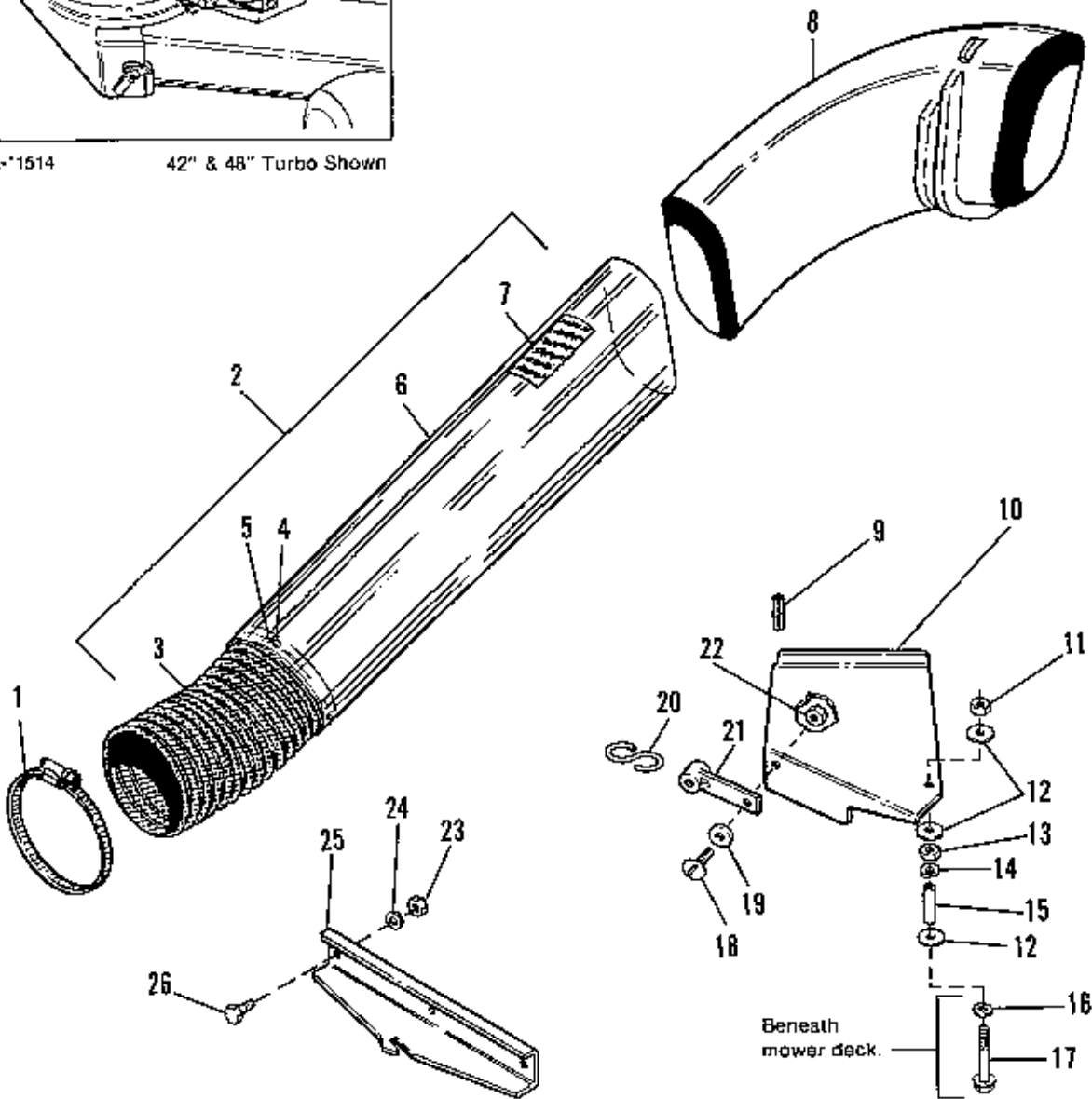

NOTE: Use standard hardware torque spec. chart unless otherwise noted.

Twin Bag Collector - Tube & Support Group

Ref. No.	Part No.	Qty.	Description
1	1679896	1	CLAMP, 6"
2	1676176	1	TUBE ASSY. (Incl. Ref. Nos. 3 - 7)
3	1679895	1	HOSE, Exhaust
4	1673320	2	RIVET, Pop
5	1910531	4	WASHER, Rivet
6	1679174	1	TUBE
7	1675766	1	DECAL, Cleaning Inst.
8	1669793	1	ELBOW, Tube to Catcher
9	1679165	1	MOULDING
10	1679133	1	COVER ASSY., Arbor
11	1917372	1	NUT, HexFull, 5/16-18
12	1920283	3	WASHER, Special
13	1923362	1	NUT, Hex, Centerlock, 5/16-18
14	1917356	1	LOCKWASHER, 5/16
15	1679085	1	SPACER
16	1919381	1	WASHER, Plain, 5/16
17	1960272	1	CAPSCREW, Hex, 5/16-18 x 5-1/2
18	1930531	1	SCREW, Truss Hd.
19	1960096	1	WASHER, Special
20	1679204	1	"S" HOOK
21	1679205	1	STRAP, Arbor Cover
22	1930627	1	NUT, Hex, Centerlock, #10-32
23	1916950	3	NUT, Hex, Full, 3/8-16
24	1916965	3	LOCKWASHER, 3/8
25	1669193	1	SUPPORT, Attachment
26	1920415	3	CAPSCREW, Hex, 3/8-16 x 1

NOTE: Ref. Nos. 9 - 22 used with 42" & 48" Turbo Blower Assys. only.

A-1151
A-1151

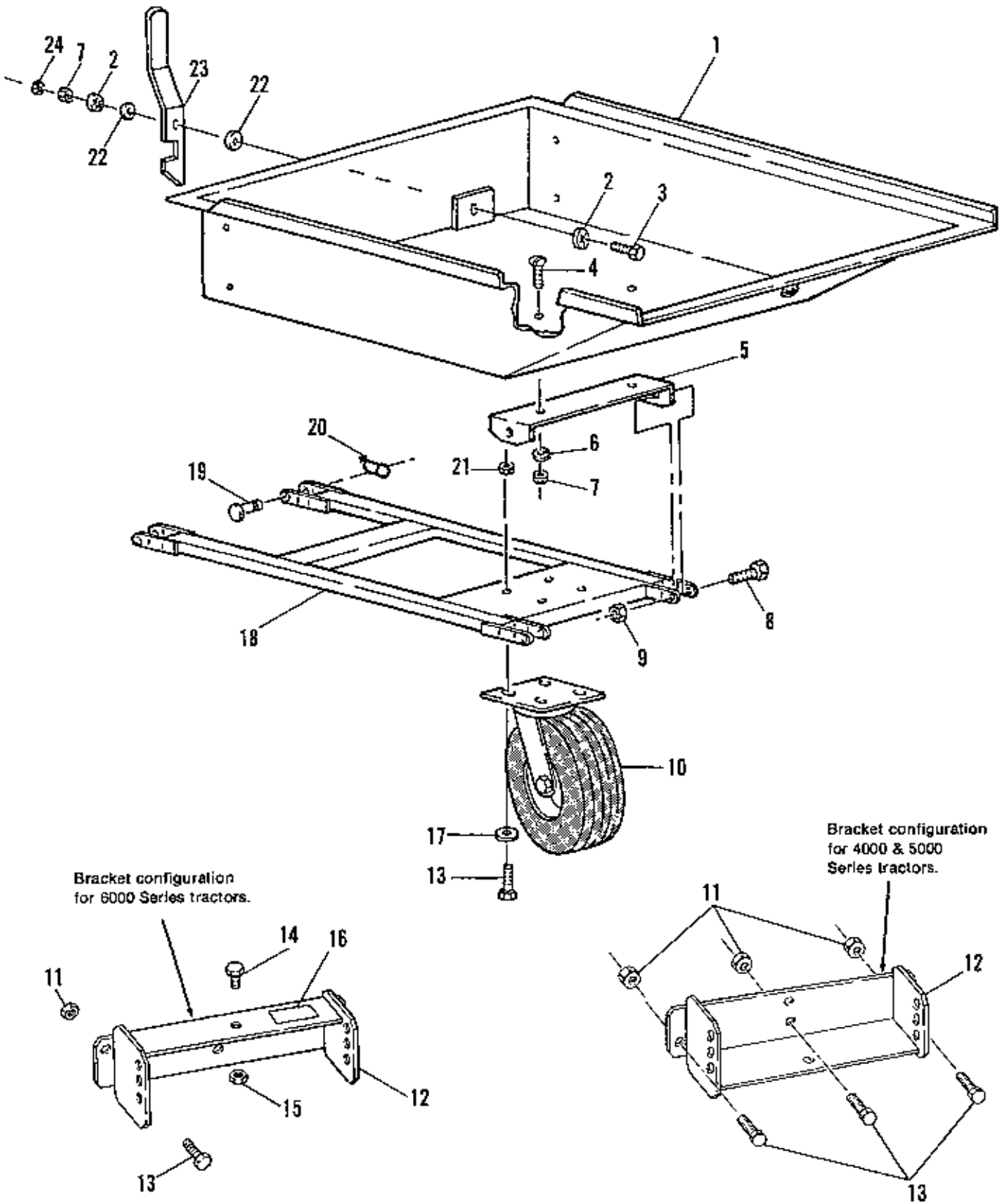

NOTE: Use standard hardware torque spec. chart unless otherwise noted.

Cart Collector - Cart Group

Ref. No.	Part No.	Qty.	Description
1	1701925	1	BOX (Order 1691243 from wholegoods.)
2	177649	2	WASHER, Spring, 5/16
3	1921977	1	CAPSCREW, Hex Hd., 5/16-18 x 1-1/4
4	1918249	2	BOLT, Slotted Truss Hd., 5/16-18 x 3/4
5	1676891	1	"U" BRACKET
6	1917358	4	LOCKWASHER, 5/16
7	1917372	4	NUT, Hex, 5/16-18
8	1921176	2	CAPSCREW, Hex Hd., 1/2-13 x 1-1/4
9	1922134	2	NUT, Hex Lock, 1/2-13
10	1676892	1	WHEEL, Sewivel
11	1930651	3	NUT, Hex Lock 3/8-16
12	1676898	1	BRACKET, Hitch
13	1921210	7	CAPSCREW, Hex, 3/8-16 x 1
14	1921965	1	CAPSCREW, Hex, 3/8-16 x 3/4 (6000 Series Tractors Only)
15	1930651	8	NUT, Hex Full Lock, 3/8-16
16	1700348	1	DECAL, Warning (6000 Series Only)
17	1917378	4	FLATWASHER, 3/8 S.A.E.
18	1676889	1	FRAME
19	102004	2	PIN, Clevis, 1/2 x 1-1/4
20	176012	2	COTTER, Hairpin
21	1930651	4	NUT, Hex Lock, 3/8-16
22	1917642	2	FLATWASHER, 5/16
23	1700765	1	HANDLE, Latch
24	1920161	1	NUT, Hex, Jam, 5/16-18

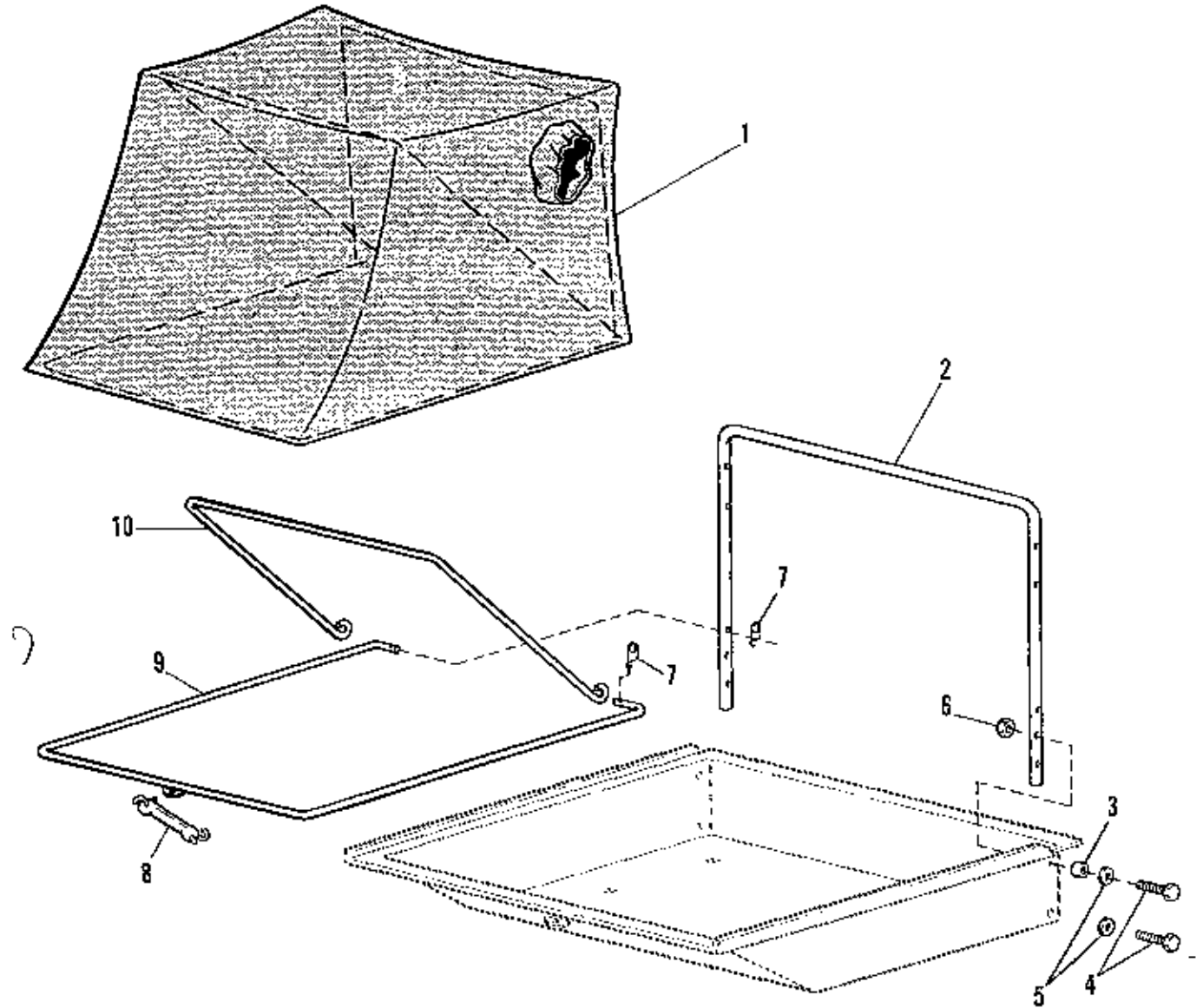

NOTE: Use standard hardware torque spec. chart unless otherwise noted.

Cart Collector - Cover Group

Ref. No.	Part No.	Qty.	Description
1	1702003	1	COVER
2	1700264	1	TUBE, Support
3	1700267	2	SPACER, Plastic
4	1921677	4	CAPSCREW, 5/16-18 x 1-1/2
5	1917642	4	WASHER, 5/16
6	1923362	4	NUT, Lock, 5/16-18
7	178012	2	COTTER, Hairpin
8	1700266	1	STRAP, Rubber
9	1700268	1	ROD, Frame
10	1700265	1	ROD, Support

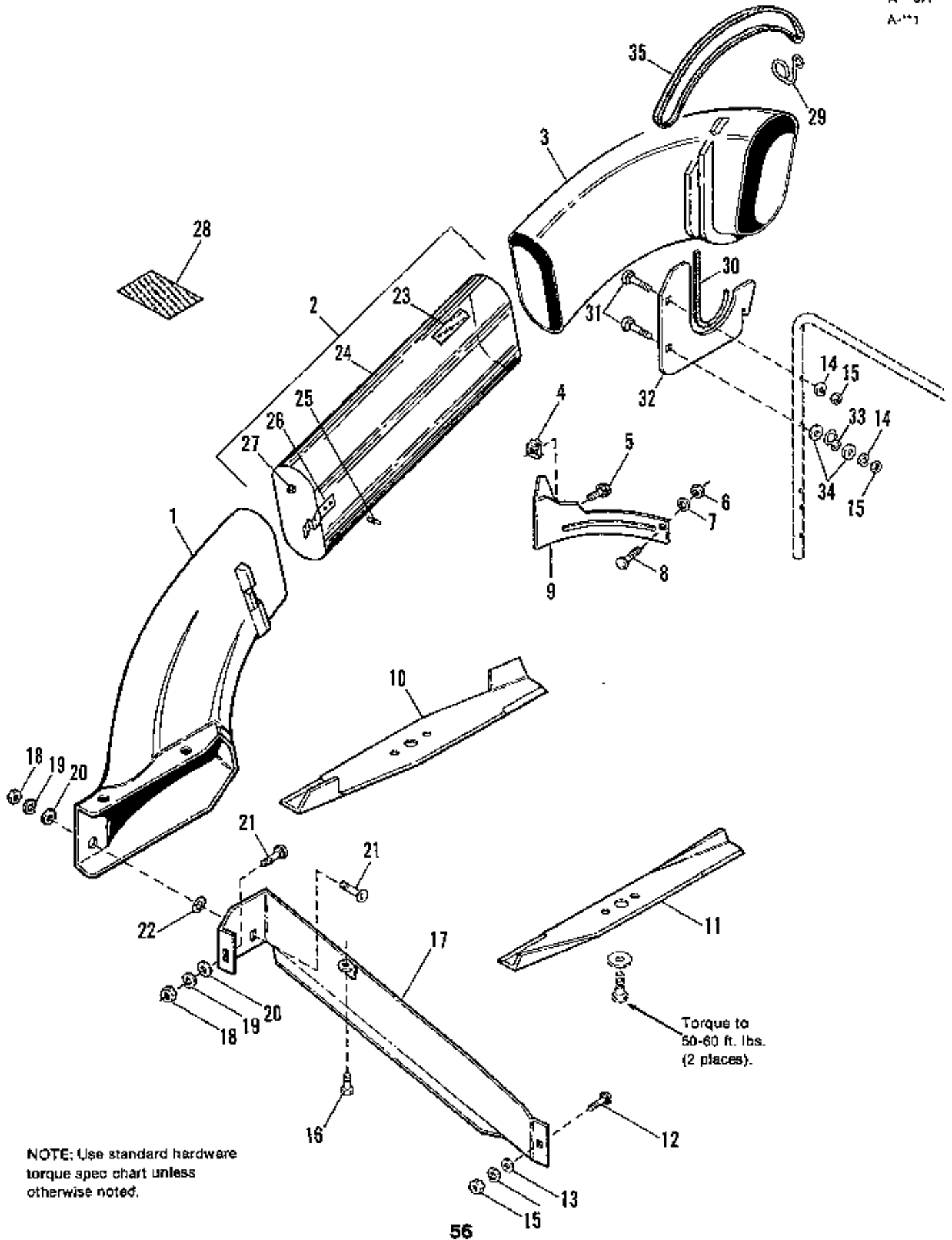

Cart Collector - Tube & Blade Group

Ref. No.	Part No.	Qty.	Description
1	1669029	1	ADAPTOR
2	1676681	1	TUBE ASSY.
3	1669793	1	ELBOW
4	920462	1	NUT, Retainer, 1/4-20
5	1931646	1	SCREW, Whizlock, 1/4-20 x 1/2
6	1916622	1	NUT, Hex, 1-4-20
7	1916964	1	LOCKWASHER, 1/4
8	1960252	1	CARRIAGE BOLT, 1/4-20 x 5/8
9	1672171	1	BAFFLE, Deflector Side
10	1671565	1	BLADE, R.H.
11	1671583	1	BLADE, L.H.
12	1931334	1	CARRIAGE BOLT, 5/16-18 x 7/8
13	1917377	1	WASHER, 1/4
14	1917356	3	LOCKWASHER, 5/16
15	1917372	3	NUT, Hex, 5/16-18
16	1924856	1	SCREW, Taptite, 5/16-18 x 1/2
17	1656053	1	BAFFLE ASSY., Discharge
18	1916950	2	NUT, Hex, 3/8-16
19	1916965	2	LOCKWASHER, 3/8
20	1917378	4	WASHER, 3/8
21	1931348	3	CARRIAGE BOLT, 3/8-16 x 3/4
22	931942	3	NUT, Push On
23	1675766	1	DECAL, (Cleaning Instructions)
24		1	TUBE (See Ref. No. 2)
25	928706	2	RIVET
26	1673757	1	SPRING, Tube, Retaining
27	910531	2	WASHER, Rivet
28	1676923	1	DECAL, Warning, Cover
29	1672688	1	HOOK, Strap
30	1673874	1	TRIM
31	1931338	2	BOLT, Rd. Hd., 5/16-18 x 1-3/4
32	1672335	1	BRACKET, Saddle
33	1672689	1	"S" HOOK
34	1917642	2	WASHER, 5/16
35	1665872	1	STRAP, Rubber

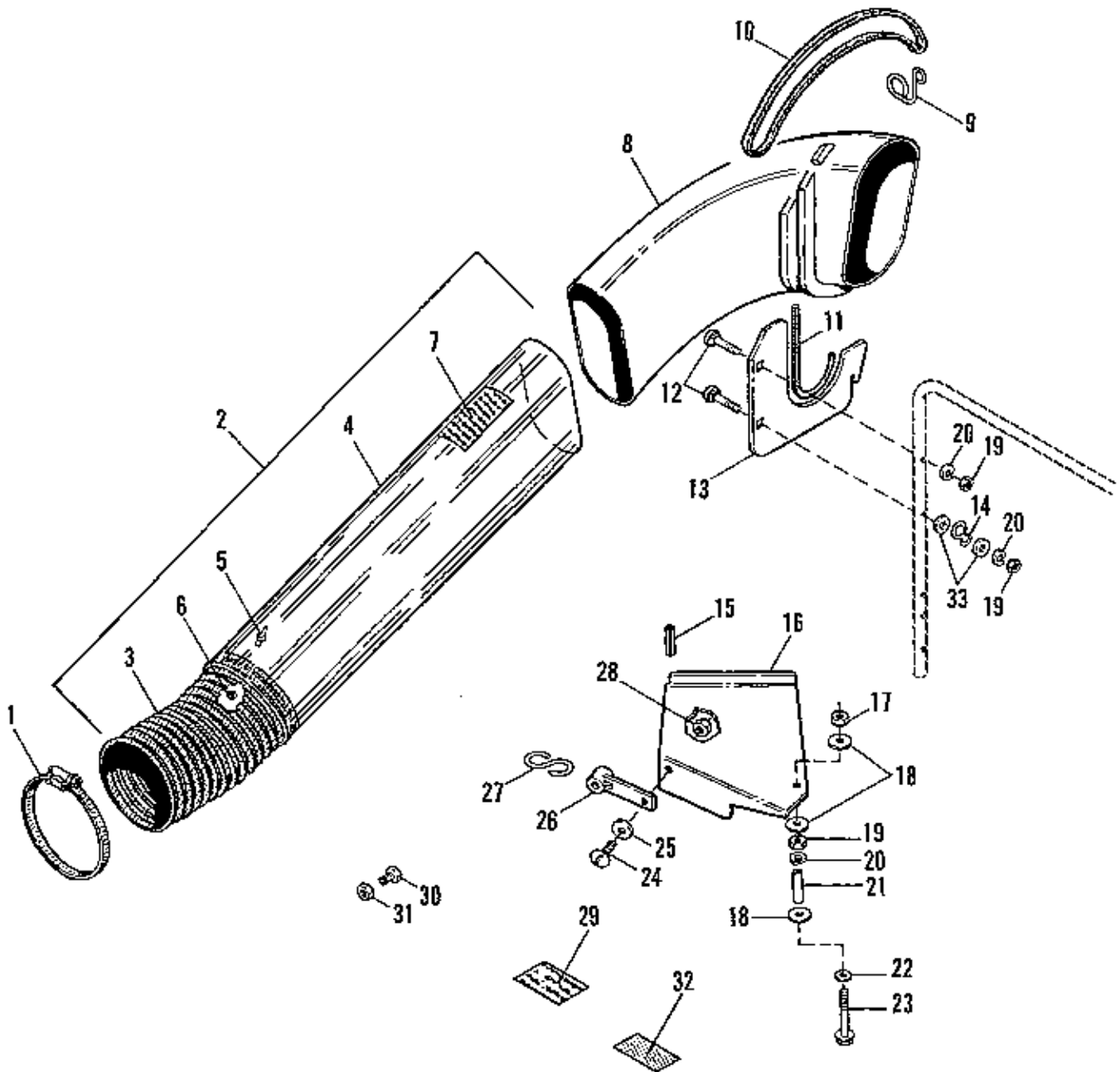

NOTE: Use standard hardware
torque spec. chart unless
otherwise noted.

Cart Collector - Tube & Support Group

Ref. No.	Part No.	Qty.	Description
1	1679896	1	CLAMP, 6"
2	1679177	1	TUBE ASSY., 38" (Incl. Ref. Nos. 3 - 7)
3	1679895	1	HOSE, Exhaust
4	1679175	1	TUBE
5	1673320	4	RIVET, Pop
6	910531	4	WASHER, Rivet
7	1675766	1	DECAL, Cleaning Instructions
8	1669793	1	ELBOW, Tube to Catcher
9	1672688	1	HOOK, Strap
10	1665872	1	STRAP, Rubber
11	1673874	1	TRIM
12	1931338	2	CARRIAGE BOLT, 5/16-18 x 1-3/4
13	1672335	1	BRACKET, Saddle
14	1672689	1	"S" HOOK
15	1679165	1	MOULDING
16	1679133	1	COVER ASSY., Arbor
17	1923362	1	NUT, Hex, Centerlock, 5/16-18
18	1920283	3	WASHER, 5/16
19	1917372	3	NUT, Hex, Full, 5/16-18
20	1917356	3	LOCKWASHER, 5/16
21	1679085	1	SPACER
22	1919381	1	WASHER, Plain, 5/16
23	1960272	1	CAPSCREW, Hex Hd., 5/16-18 x 5-1/2
24	1930531	1	SCREW, Truss Hd., #10-32 x 1/2
25	1960096	1	WASHER, Plain
26	1679205	1	STRAP, Arbor Cover
27	1679204	1	"S" HOOK
28	1930627	1	NUT, Hex, Centerlock, #10-32
29	1676923	1	DECAL, Warning, Cover
30	1921965	1	CAPSCREW, Hex Hd., 3/8-16 x 3/4
31	1930651	1	NUT, Hex, Full Lock, 3/8-16
32	1700346	1	DECAL, Warning
33	1917642	2	WASHER, Plain, 5/16

Note: Ref. Nos. 15 - 29 and Ref. No. 32 used with
42" & 48" Turbo Blowers only.

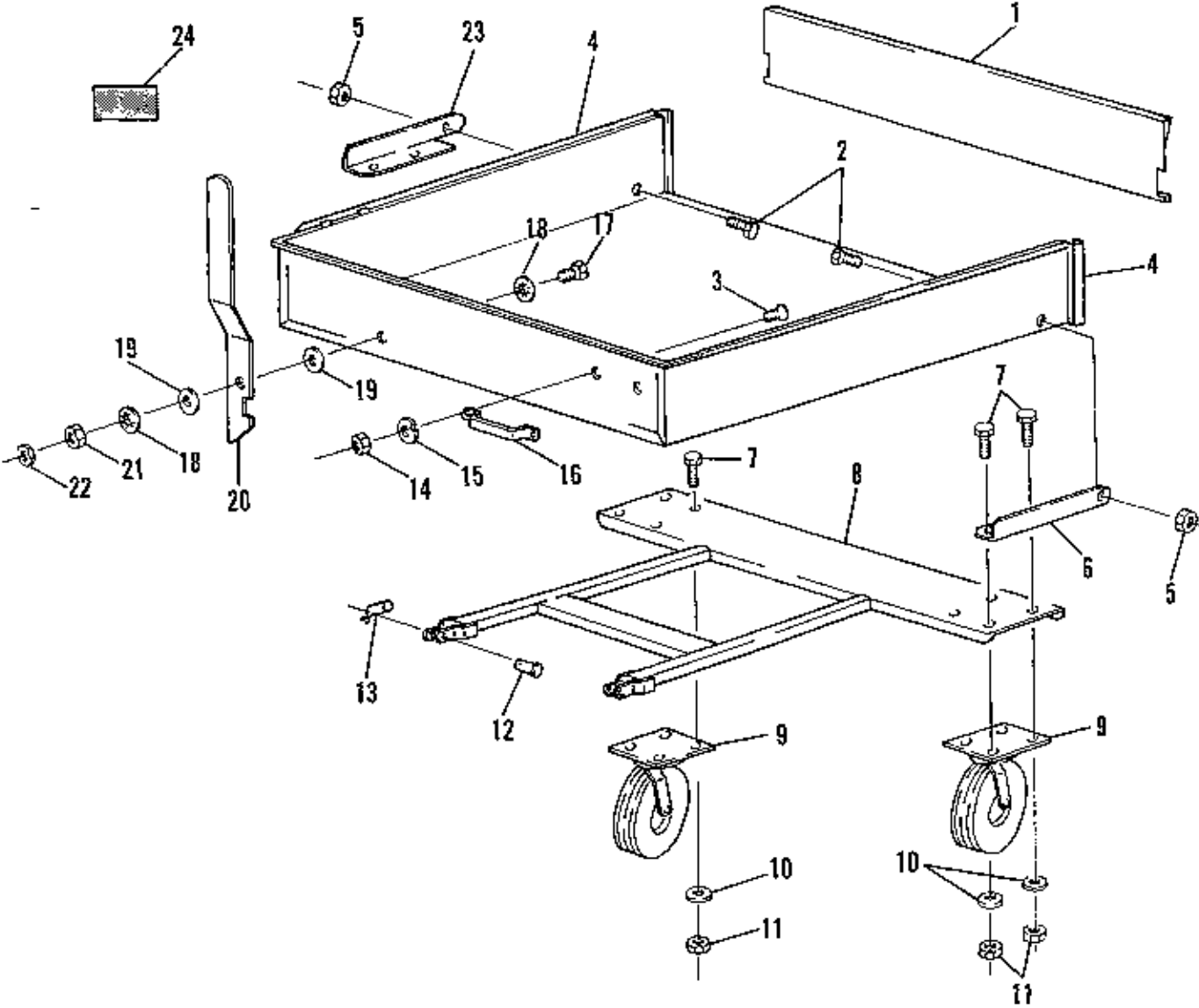

NOTE: Use standard hardware torque spec. chart unless otherwise noted.

Quad Bagger Dump Cart Group

Ref. No.	Part No.	Qty.	Description
1	1703337	1	TAILGATE
2	1923114	2	CAPSCREW, 1/2-13 x 1
3	1921958	2	CAPSCREW, Hex, 1/4-20 x 1/2
4	1703338	1	BOX
5	1922134	2	NUT, Hex, Lock, 1/2-13
6	1703334	1	BRACKET, Pivot, L.H.
7	1921210	8	CAPSCREW, Hex
8	1703336	1	FRAME
9	1676892	2	WHEEL, Swivel
10	1917378	8	WASHER, 3/8
11	1930651	8	NUT, Hex, Lock, 3/8-16
12	102004	2	PIN, Clevis, 1/2 x 1-1/2
13	176012	2	PIN, Safety
14	1916622	2	NUT, Hex, 1/4-20
15	1916964	2	LOCKWASHER, 1/4
16	1700768	1	HANDLE, Lift
17	1921977	1	CAPSCREW, 5/16-18 x 1-1/4
18	1917642	2	WASHER, 5/16
19	1700766	2	WASHER, Spring, 5/16
20	1700765	1	HANDLE, Latch
21	1917372	1	NUT, Hex, Full, 5/16-18
22	1920161	1	NUT, Hex, Jam, 5/16-18
23	1703335	1	BRACKET, Pivot, R.H.
24	1703370	1	DECAL, Max. Capacity

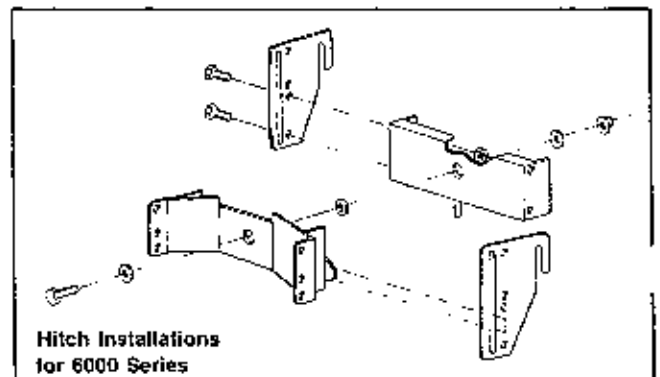
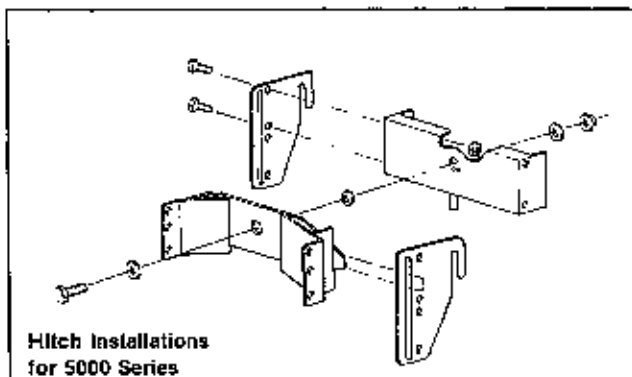
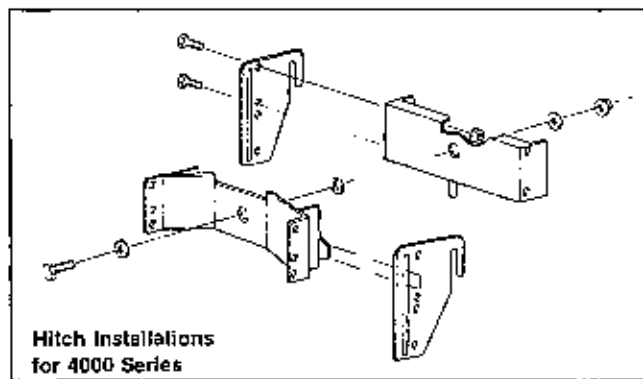
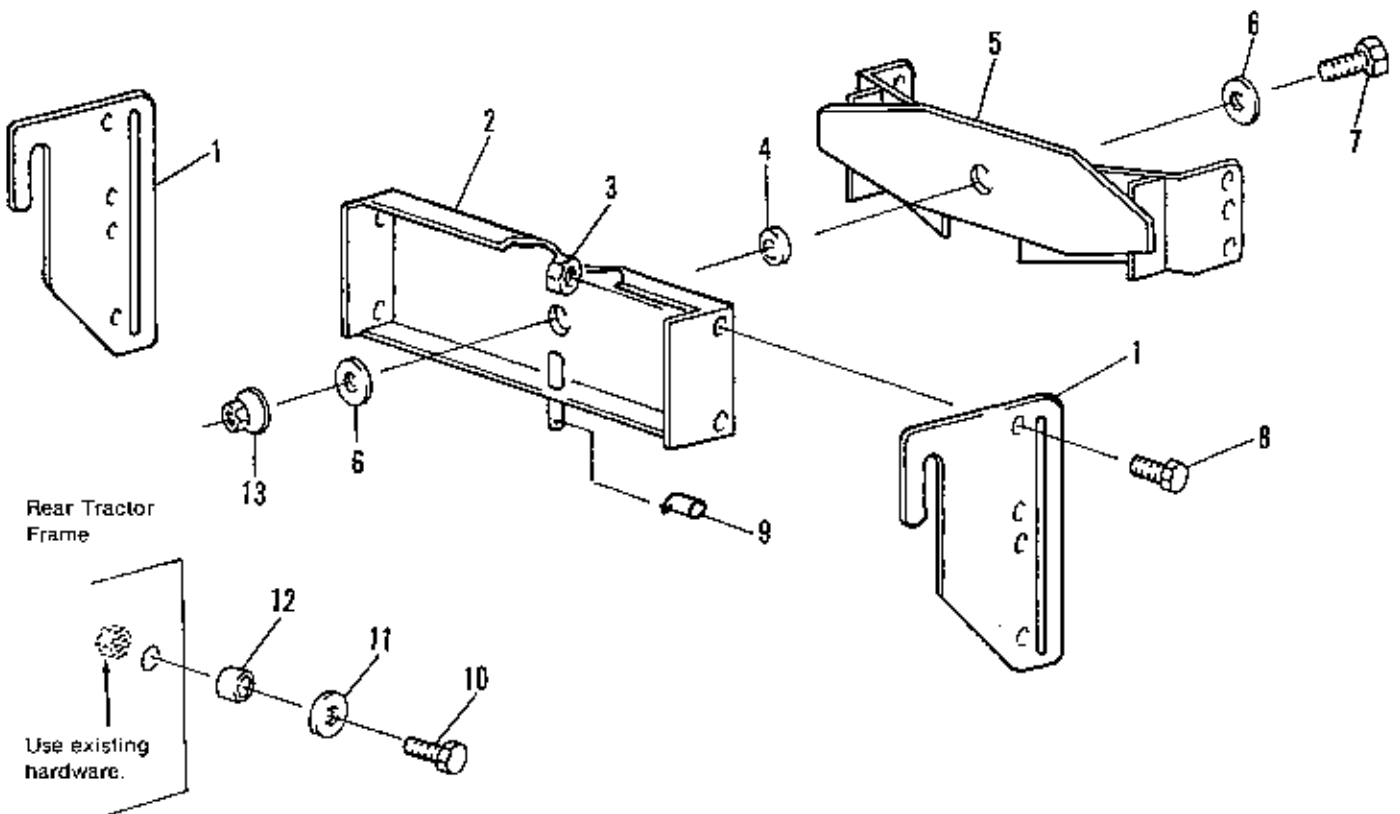

Quad Bagger Cart Hitch Group

Ref. No.	Part No.	Qty.	Description
1	1703160	2	PLATE, Hitch, Side
2	1703018	1	SUPPORT ASSY., Hitch
3	1930651	4	NUT, Hex, Lock, 3/8-16
4	1703211	1	SPACER
5	1703198	1	PIVOT HITCH ASSY.
6	960154	2	FLATWASHER, 1/2
7	1921176	1	CAPSCREW, 1/2-13 x 1-1/4
8	1921965	4	CAPSCREW, 3/8-16 x 3/4
9	176012	1	PIN, Safety
10	1920415	2	CAPSCREW, 3/8-16 x 1-1/4
11	1917378	2	FLATWASHER, 3/8
12	158227	2	SPACER
13	1930644	1	NUT, Flange Lock, 1/2-13

Quad Bagger - Tube & Pulley Cover Assy.

Ref. No.	Part No.	Qty.	Description
1	1669793	1	ELBOW
2	1679165	1	MOULDING
3	1679133	1	COVER ASSY.
4	1923382	2	LOCKNUT, Hex, Full, 5/16-18
5	1920283	3	WASHER, Special
6	1917372	1	NUT, Hex, Full, 5/16-18
7	1917356	1	LOCKWASHER, 5/16
8	1679085	1	SPACER
9	1919381	1	WASHER, Plain, 5/16
10	1960272	1	CAPSCREW, Hex, 5/16-18 x 5-1/2
11	1930531	1	SCREW, Truss Hd., #10-32 x 1/2
12	1960096	1	WASHER, Special
13	1679205	1	STRAP
14	1679204	1	"S" HOOK
15	1930627	1	NUT, Hex, Full Lock, #10-32
16	1679896	1	CLAMP, 6" I.D.
17	1701885	1	TUBE ASSY., (Incl. Ref. Nos. 18 - 22)
18	1679895	1	HOSE, 6" I.D.
19	910531	4	WASHER, Rivet
20	1673320	4	RIVET, Pop
21	1701864	1	TUBE
22	1675766	1	DECAL, Cleaning Instructions

NOTE: Ref. Nos. 2-15 used on 41" & 48" Turbo Blower Assys. only.

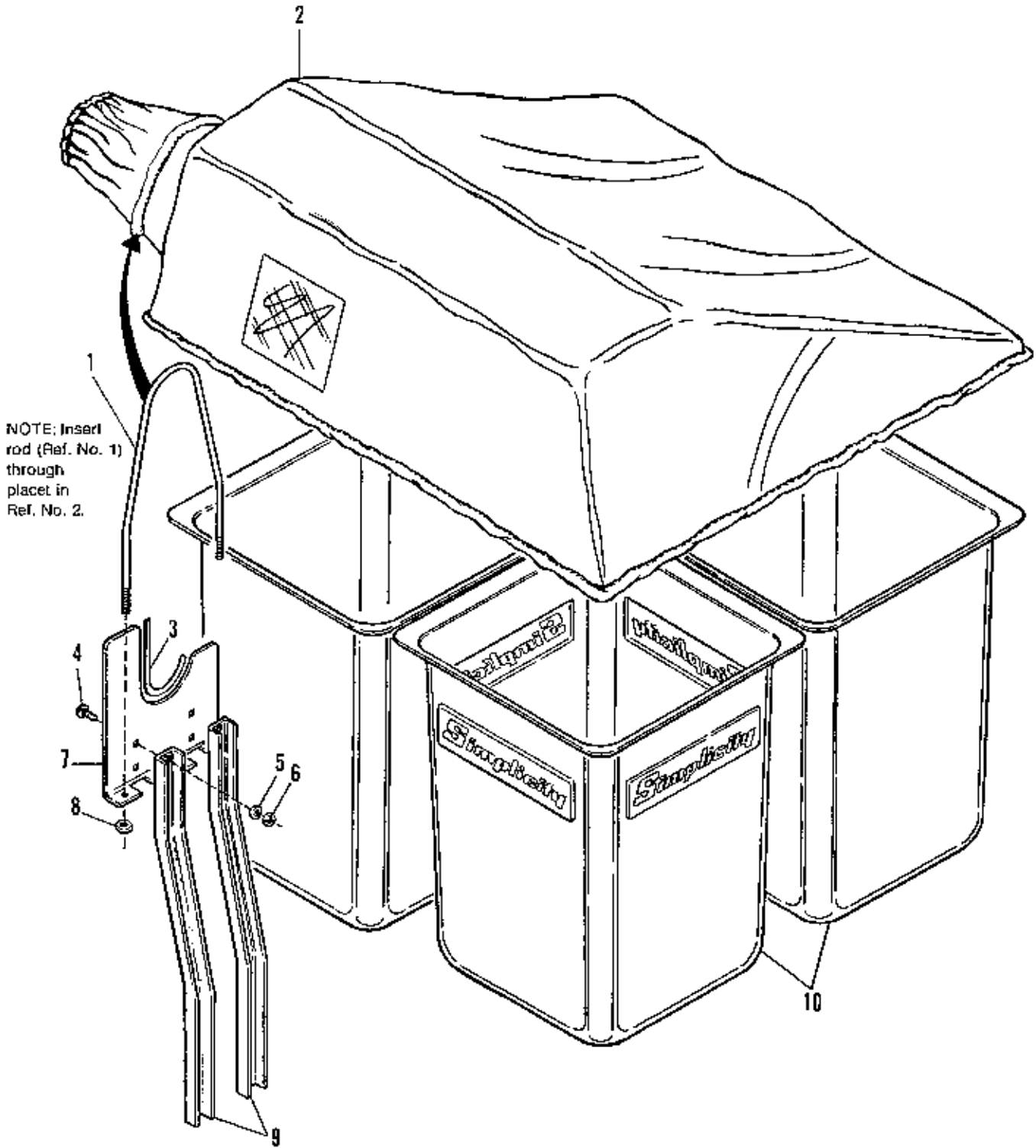

NOTE: Use standard hardware torque spec. chart unless otherwise noted.

Quad Bagger - Cover & Support Group

Ref. No.	Part No.	Qty.	Description
1	1702829	1	CLAMP, Elbow
2	1702243	1	HOOD
3	1673874	1	TRIM
4	1960252	4	CARRIAGE BOLT, 1/4-20 x 5/8
5	1916964	4	LOCKWASHER, Spring, 1/4
6	1916622	4	NUT, Hex, 1/4-20
7	1702827	1	BRACKET, Saddle
8	1923362	2	LOCKNUT, Hex, Full, 5/16-18
9	1702826	2	CHANNEL, Support
10	1702186	4	BASKET, Grass

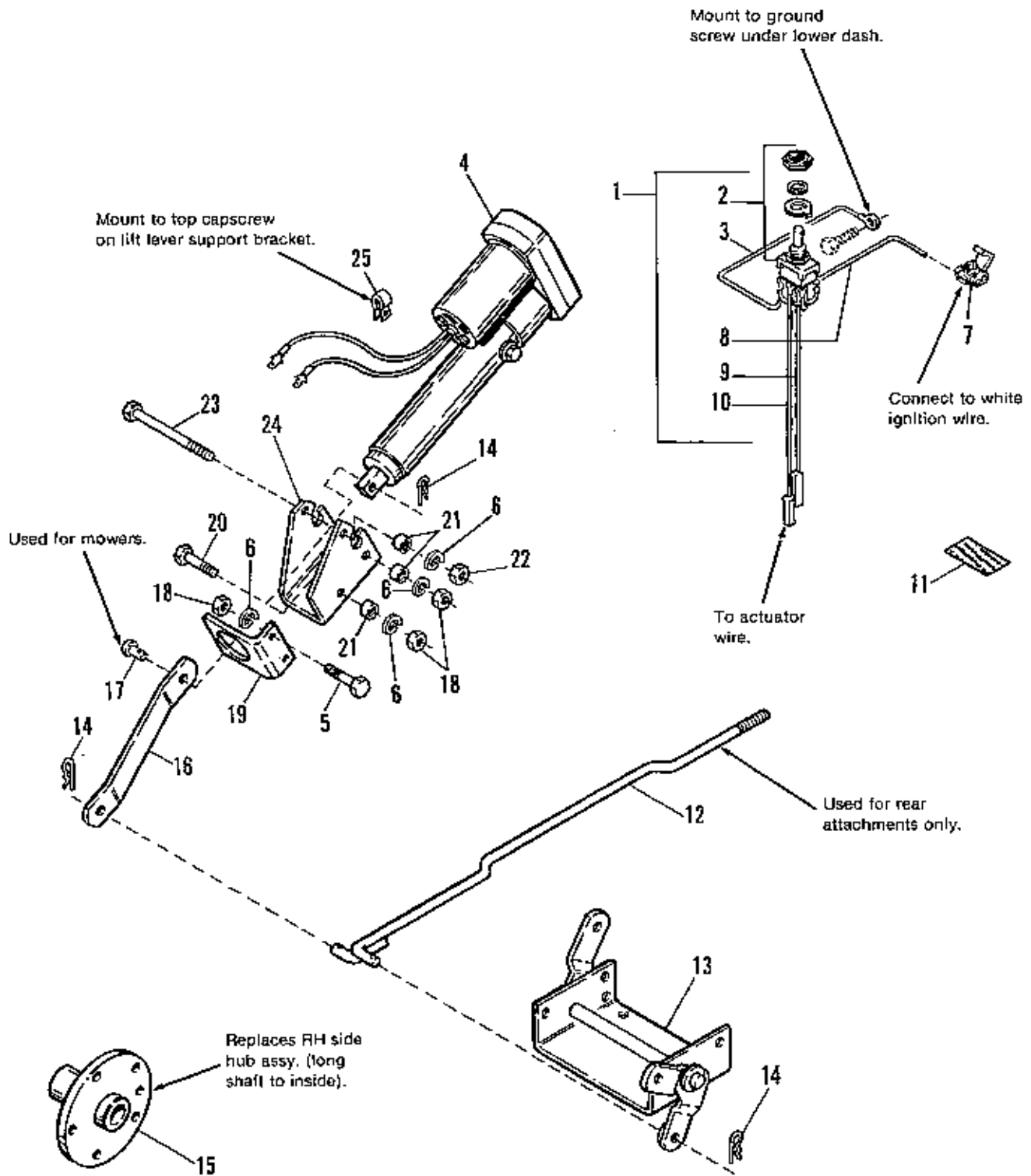

NOTE: Use standard hardware torque spec. chart unless otherwise noted.

Electric Lift Kit

Ref. No.	Part No.	Qty.	Description
1	1702082	1	HARNES ASSY., Electric Lift
2	171683	1	SWITCH, Electric
3	171689	1	WIRE, Switch to Ground
4	1667754	1	POWER LIFT ASSY. (See pages 66 & 67 for parts breakdown.)
5	1921333	2	CAPSCREW, Hex Hd., 5/16-18 x 1
6	1917356	4	LOCKWASHER, 5/16
7	1805751	1	CONNECTORS, Self-Stripping
8	1702075	1	WIRE, Switch to ignition
9	1702077	1	WIRE, Switch to Lift
10	1702076	1	WIRE, Switch to Lift
11	1669833	1	DECAL, Lift Switch
12	1701880	1	ROD ASSY., Lift
13	1701908	1	ROD ASSY., Lift
14	1960033	3	PIN, Quick
15	1701914	1	HUB ASSY., Wheel
16	1701881	1	LINK, Actuator
17	102004	2	PIN, Pivot
18	1917372	4	NUT, Hex, 5/16-18
19	1701878	1	BRACKET, Actuator, Front
20	1921677	2	CAPSCREW, Hex Hd., 5/16-18 x 1-1/2
21	1665699	3	SPACER
22	1923362	1	NUT, Hex, Lock 5/16-18
23	1925692	1	CAPSCREW, Hex, Hd., 5/16-18 x 4-1/2
24	1701877	1	BRACKET, Actuator
25	1708008	1	CLAMP, Insulated

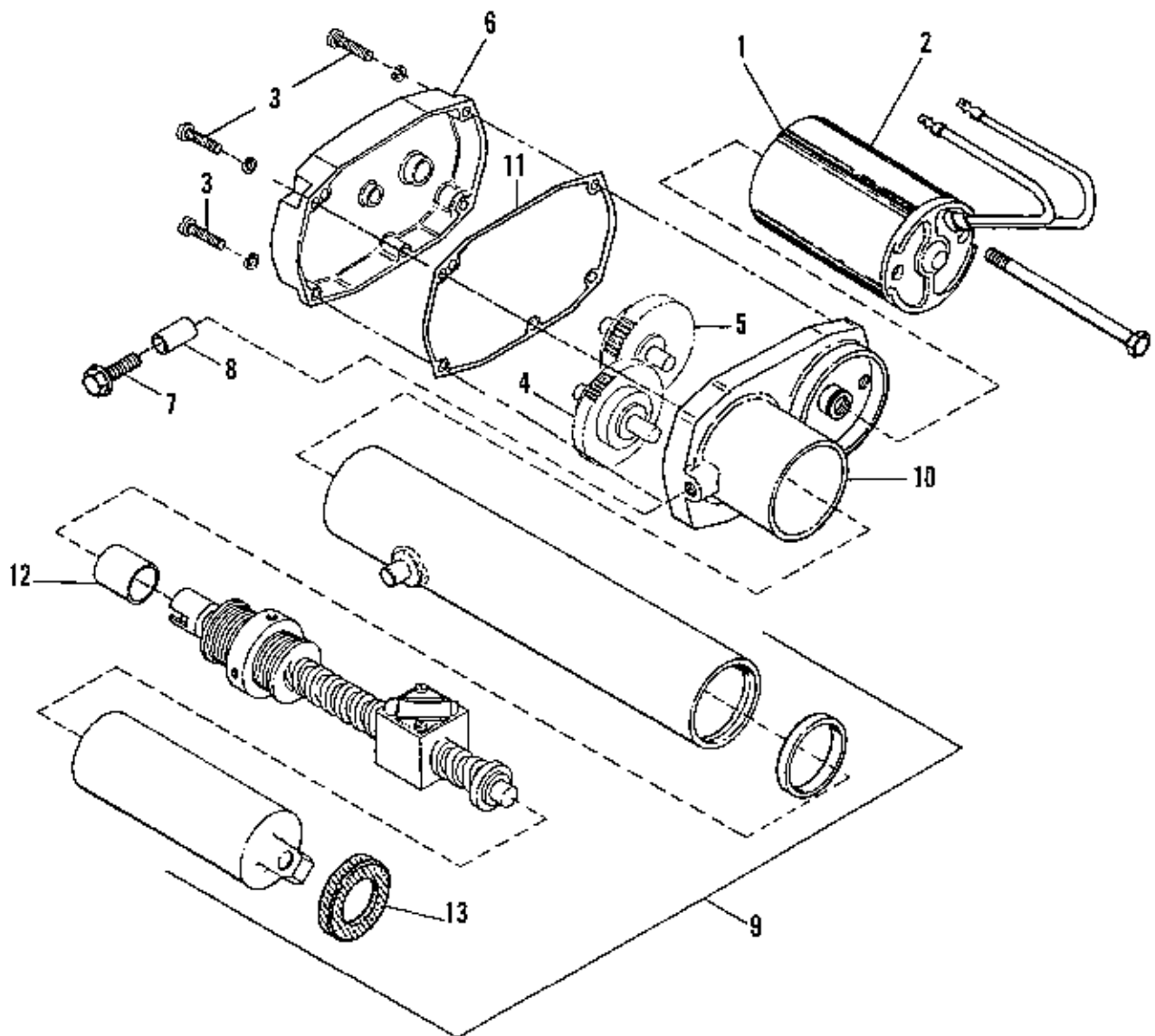

NOTE: Use standard hardware torque spec. chart unless otherwise noted.

Power Lift Assy.

Ref. No.	Part No.	Qty.	Description
1	1664756	1	BRUSH, w/Spring Set (Motor)
2	1663966	1	12 VOLT DC MOTOR
3	928589	4	SCREW, Filister Hd.
4	1670755	1	GEAR ASSY., 4th
5	1670754	1	GEAR ASSY., 2nd & 3rd
6	1664757	1	COVER, Housing
7	1605773	1	CAPSCREW, Thd. Forming
8	1605778	1	PIN, Drive
9	1667787	1	BALL SCREW ASY.
10	1664758	1	HOUSING, Motor
11	1667788	1	GASKET, Cover
12	1605779	1	SLEEVE
13	1703531	1	SEAL, Rubber

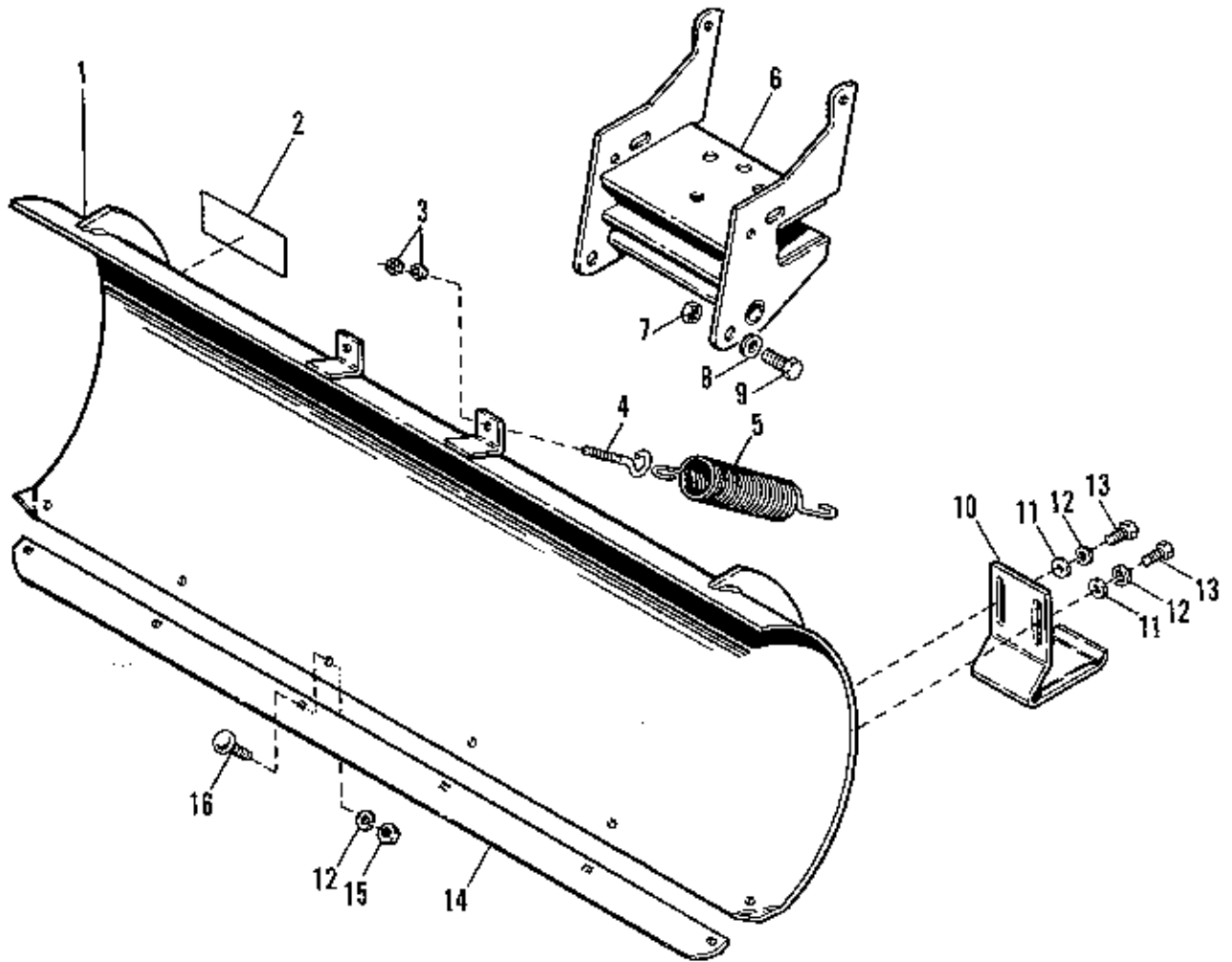

NOTE: Use standard hardware torque spec. chart unless otherwise noted.

42" Dozer Blade

Ref. No.	Part No.	Qty.	Description
1	1701477	1	BLADE ASSY.
2		1	I.D. PLATE
3	1917372	4	NUT, Hex, Full, 5/16-18
4	1675198	2	EYEBOLT
5	101126	2	SPRING, Tension
6	1701482	1	FRAME ASSY., Front
7	1922134	2	NUT, Hex Lock, 1/2-13
8	105051	2	SPACER
9	1920328	2	CAPSCREW, Hex, 1/2-13 x 1
10	107106	2	SHOE ASSY.
11	1917378	4	WASHER, Plain, 3/8
12	1916965	10	LOCKWASHER, 3/8
13	1921965	4	CAPSCREW, Hex Hd. , 3/8-16 x 3/4
14	107045	1	PLATE, Wear
15	1916950	6	NUT, Hex, Full, 3/8-16
16	1931350	6	CARRIAGE BOLT, 3/8-16 x 1

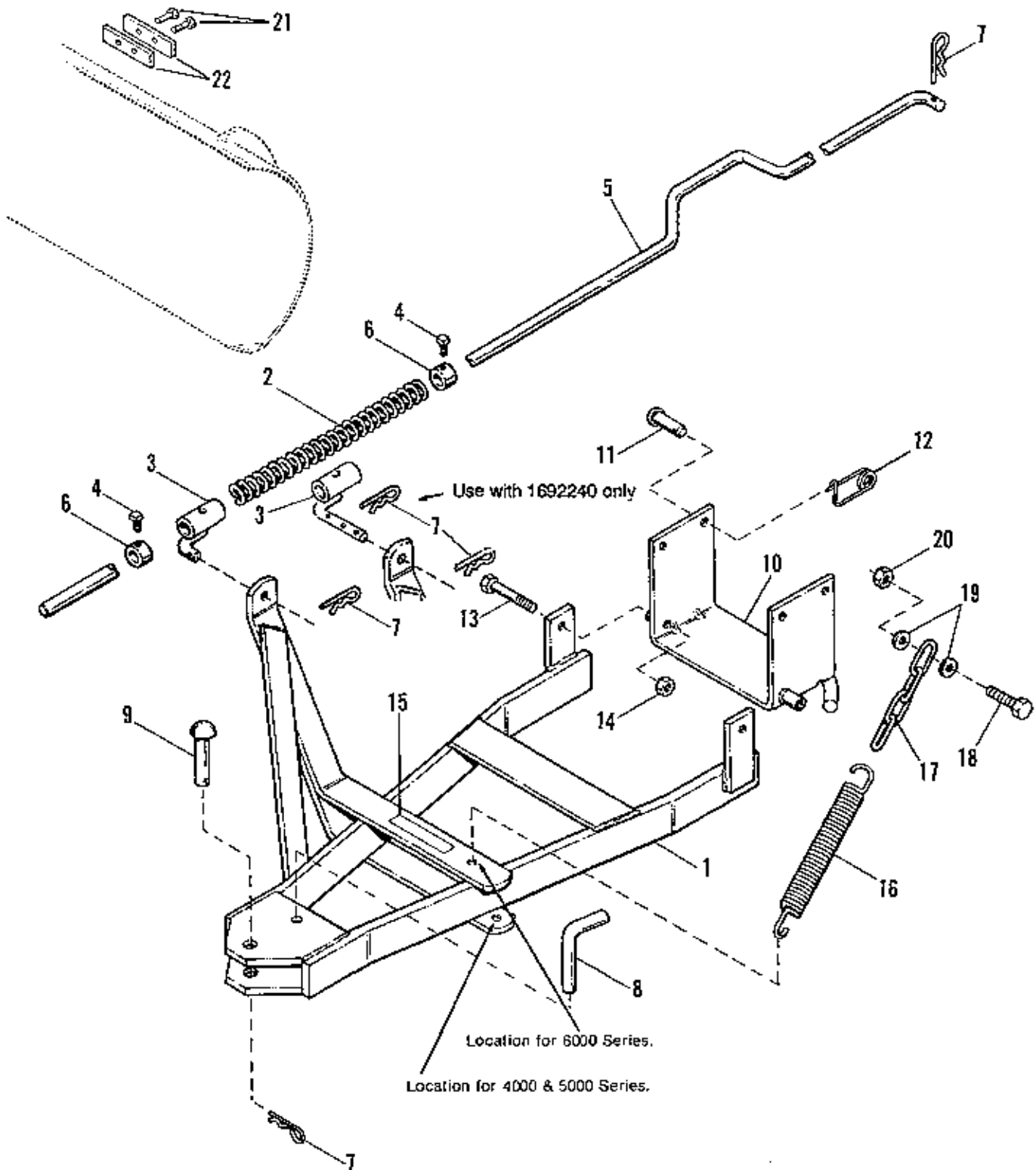

NOTE: Use standard hardware
torque spec. chart unless
otherwise noted.

42" Snow Plow & Dozer Blade Hitch Group

Ref. No.	Part No.	Qty.	Description
1	1607911	1	BAR ASSY., Push
2	171011	1	SPRING
3	171679	1	GUIDE ASSY., Rod (1691523 only)
	1709285	1	GUIDE ASSY., Rod (1692240 only)
4	1928721	2	SETSCREW, 5/16-18 x 1/2
5	1665887	1	ROD, Lift
6	6031007	2	COLLAR, Set
7	1960033	4	SPRING, Clip (Qty. 3, 1691523 only)
8	1678549	1	PIN, Pivot
9	1603602	1	PIN, King
10	1657663	1	BRACKET ASSY.
11	156306	4	PIN
12	176012	4	CLIP, Pin
13	1922130	2	CAPSCREW, 3/8-16 x 2-1/4
14	1930645	2	NUT, Lock, 3/8-16
15		1	I.D. PLATE
16	1675632	1	SPRING
17	1669241	1	CHAIN, 4-Link
18	1921977	1	CAPSCREW, 5/16-18 x 1-1/4
19	1919381	2	WASHER, Plain, 5/16
20	1923362	1	NUT, Hex, Lock, 5/16-18
21	1709813	2	BAR STOP (1692240 only)
22	1960373	2	SCREW, Hex, Taprite, 5/16-18 x 1 (1692240 only)

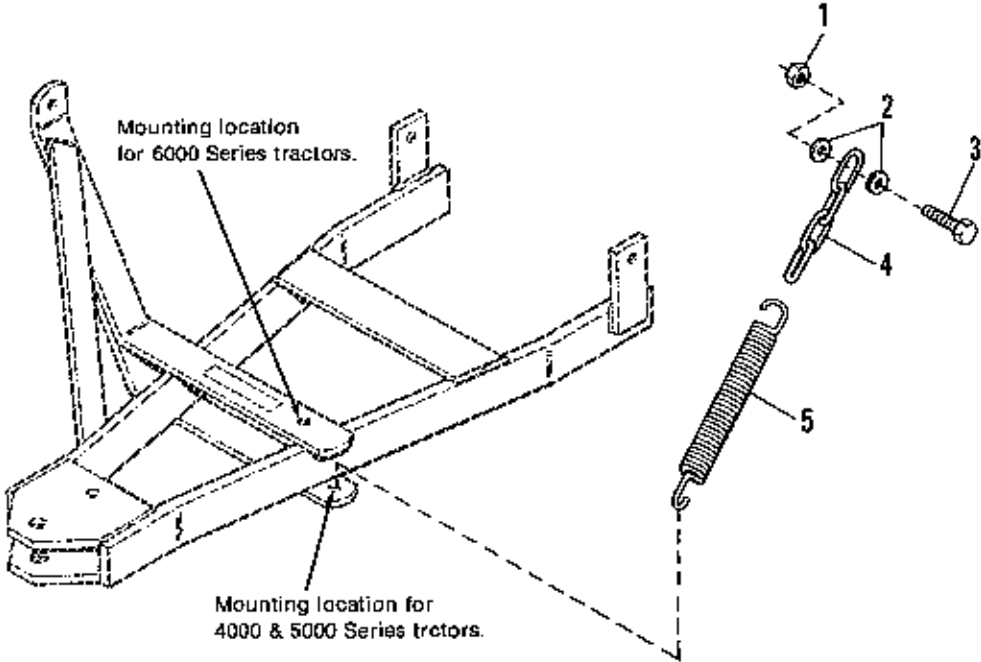

NOTE: Use standard hardware torque spec. chart unless otherwise noted.

Spring Assisted Lift Kit (36" & 42" Snowthrowers)

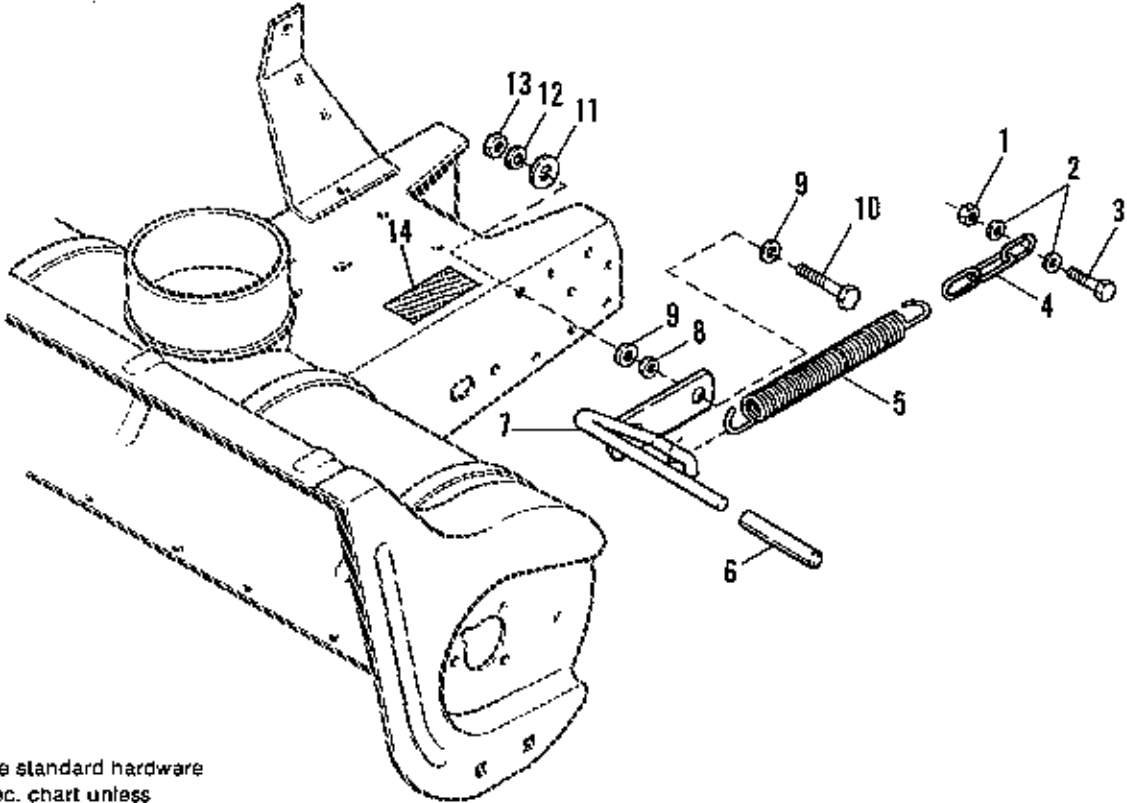

NOTE: Use standard hardware torque spec. chart unless otherwise noted.

Mfg. No. 1685336

Spring Assisted Lift Kit (42" Dozer)

Ref. No.	Part No.	Qty.	Description
1	1923362	1	NUT, Hex, Lock, 5/16-18
2	1919381	2	WASHER, Plain, 5/16
3	1921977	1	CAPSCREW, 5/16-18 x 1-1/4
4	1669241	1	CHAIN, 4-Links
5	1675232	1	SPRING

Mfg. No. 1685337

Spring Assisted Lift Kit (36" & 42" Snowthrowers)

Ref. No.	Part No.	Qty.	Description
1	1923362	1	NUT, Hex, Lock, 5/16-18
2	1919381	2	WASHER, Plain, 5/16
3	1921977	1	CAPSCREW, 5/16-18 x 1-1/4
4	1656835	1	CHAIN, 3-Links
5	1675232	1	SPRING
6	176934	1	GRIP
7	1701917	1	LEVER ASSY., Spring
8	108717	1	SPACER
9	1924356	2	WASHER
10	1921969	1	CAPSCREW, 3/8-16 x 1-1/2
11	1922755	1	WASHER, 13/32 x 1
12	1916965	1	LOCKWASHER, 3/8
13	1916950	1	NUT, Hex, Full, 3/8-16
14	1701940	1	DECAL, Caution

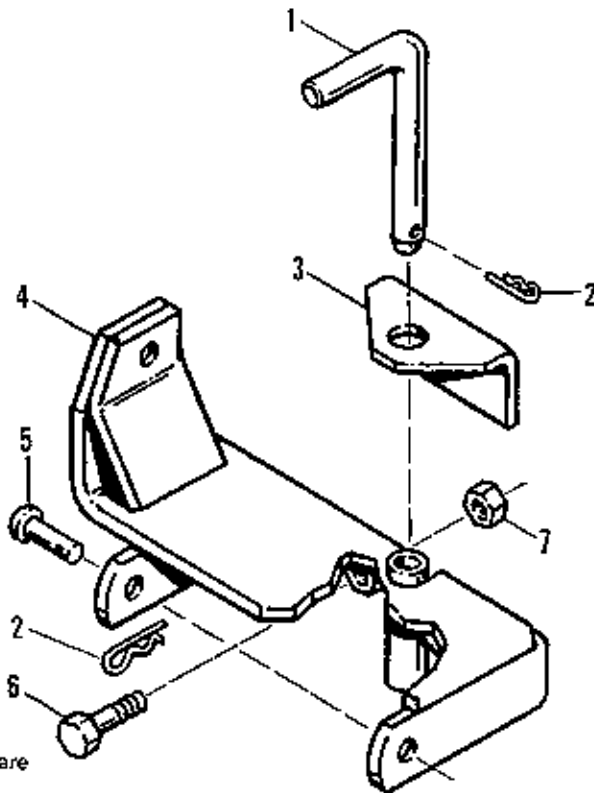

NOTE: Use standard hardware torque spec. chart unless otherwise noted.

Rear Implement Attachment Kit (For Rear Mounted Vac. Collector to 5200)

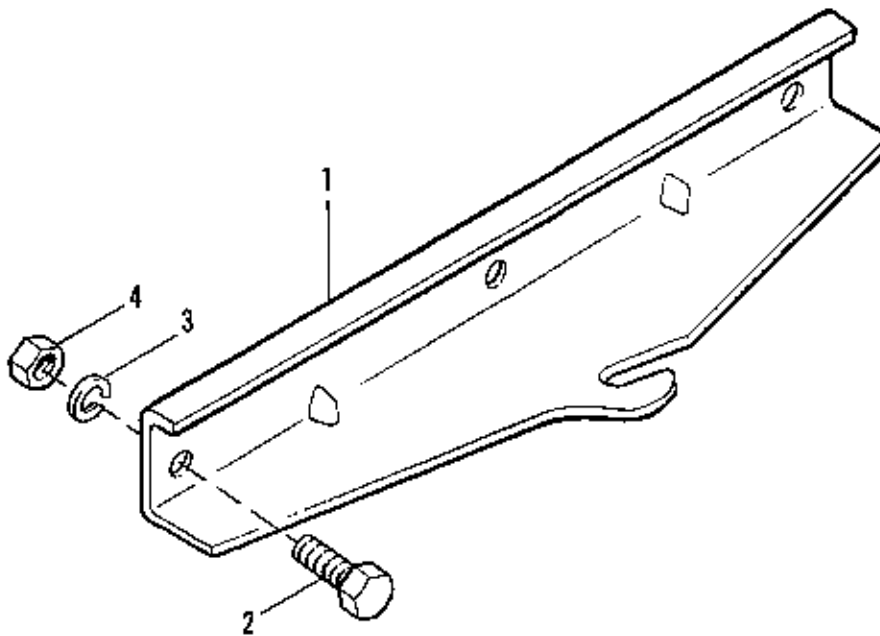

NOTE: Use standard hardware torque spec. chart unless otherwise noted.

Mfg. No. 1690389

One Point Hitch Group

Ref. No.	Part No.	Qty.	Description
1	1603321	1	PIN, Hitch
2	106788	3	CLIP, Spring
3	1603816	1	PLATE, Stabilizer
4	1665448	1	CLEVIS & LIFT ARM ASSY.
5	155037	2	PIN
6	1927430	2	CAPSCREW, Hex Hd., 5/8-11 x 2-1/4
7	1915726	2	NUT, Hex, Jam, 5/8-11

Mfg. No. 1685200

Rear Implement Attachment Kit (For Rear Mounted Vac. Collector to 6200)

Ref. No.	Part No.	Qty.	Description
1	1669193	1	SUPPORT, Attachment
2	1921210	3	CAPSCREW, Hex Hd., 3/8-16 x 1
3	1920415	3	LOCKWASHER, 3/8
4	1916950	3	NUT, 3/8-16

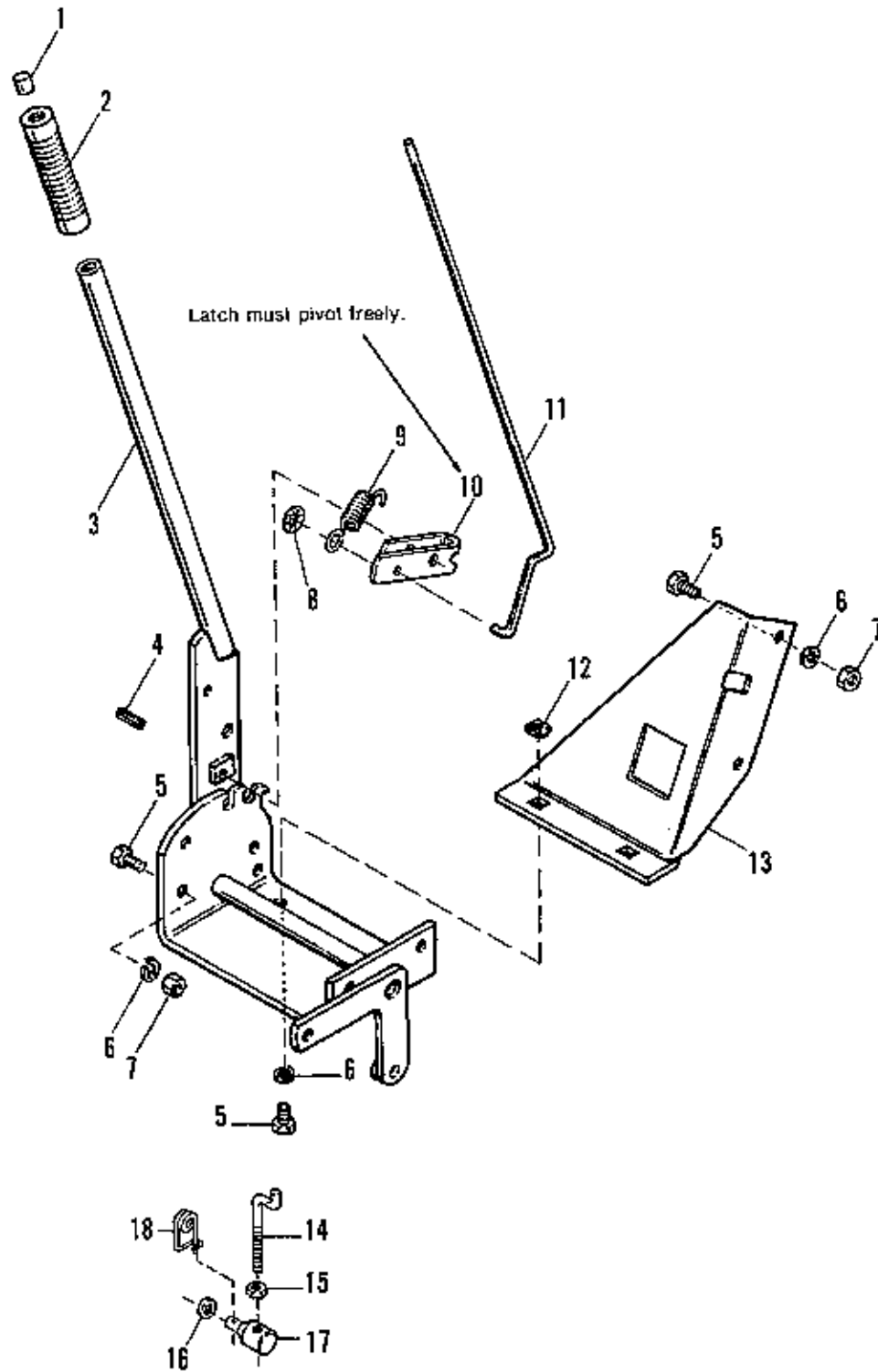

NOTE: Use standard hardware
torque spec chart unless
otherwise noted.

Lift Lever Kit

Ref. No.	Part No.	Qty.	Description
1	1650517	1	BUTTON
2	156209	1	GRIP
3	1667295	1	LEVER ASSY., Lift
4	1927609	1	PIN, Roll
5	1921332	7	CAPSCREW, Hex Hd., 5/16-18 x 3/4
6	1917356	7	LOCKWASHER, 5/16
7	1917372	5	NUT, Hex, 5/16-18
8	934953	1	PUSHNUT
9	1667286	1	SPRING
10	1657648	1	LATCH, Lever
11	1667290	1	ROD, Latch
12	916159	2	NUT, Speed, 5/16-18
13	1701223	1	BRACE, Lift Lever
14	1673665	1	ROD, Lift
15	1920161	1	NUT, Jam, 5/16-18
16	1917642	1	WASHER, 5/16
17	172141	1	TRUNNION, Pivot
18	176012	1	CUP, Safety

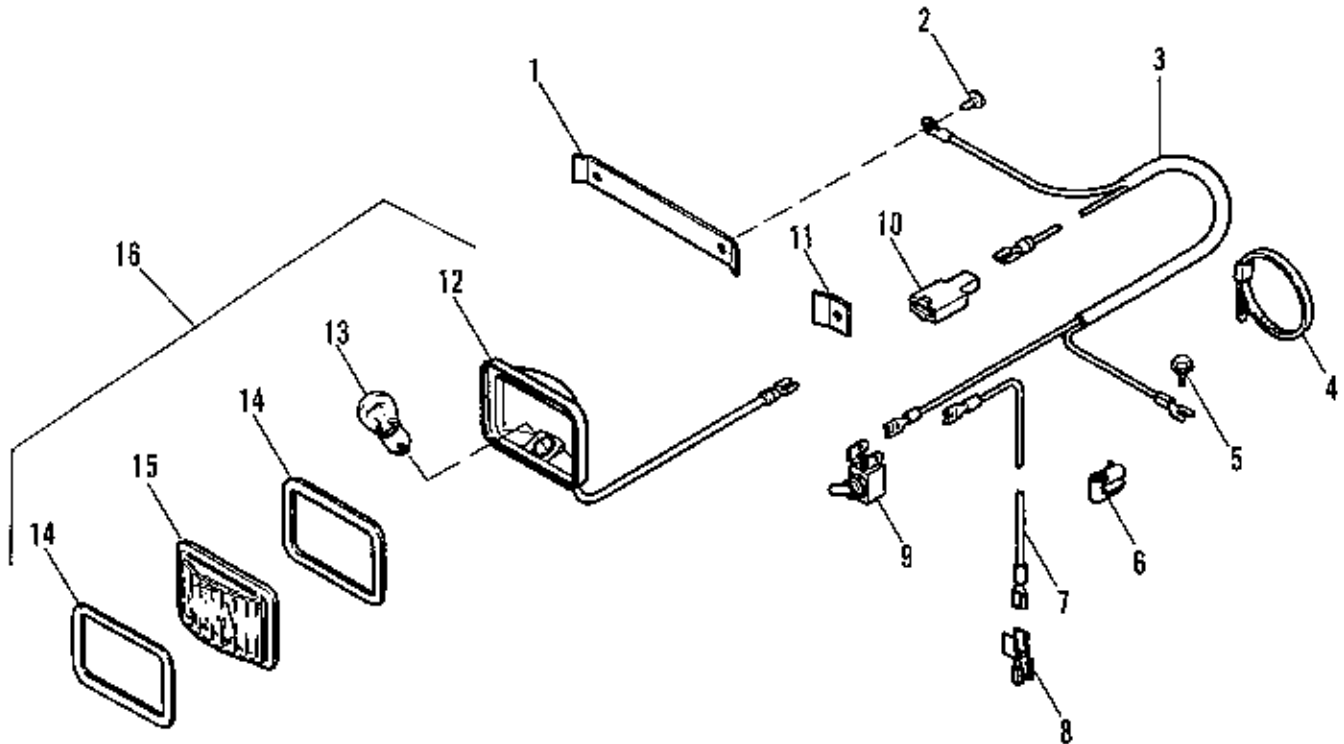

NOTE: Use standard hardware torque spec. chart unless otherwise noted.

Hitch & Lift Kit for Tiller

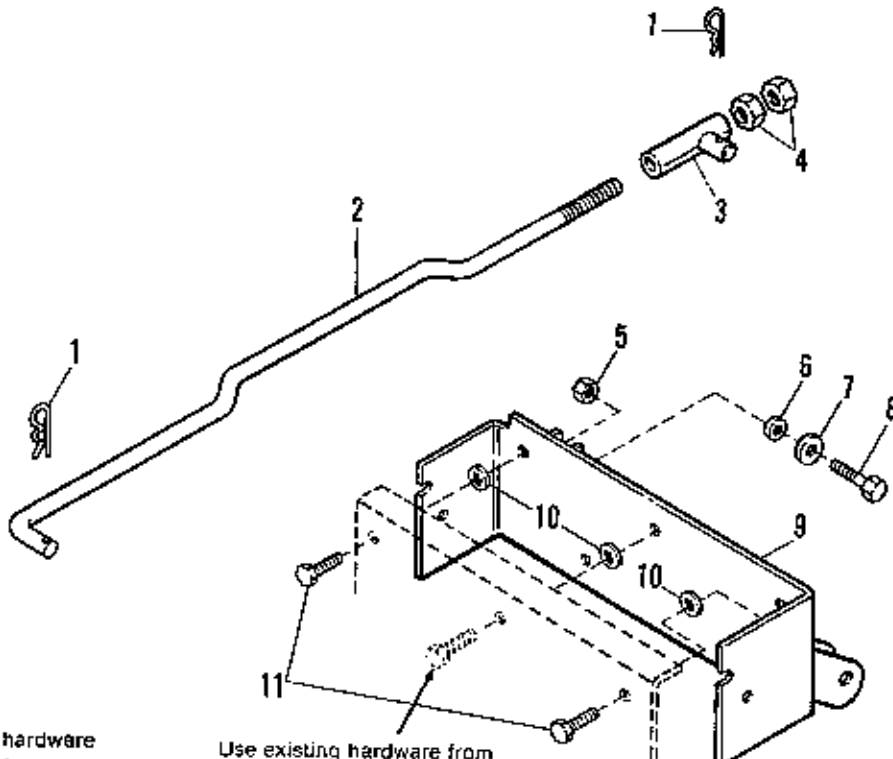

NOTE: Use standard hardware torque spec. chart unless otherwise noted.

Use existing hardware from outside hole location.

Headlight Kit

Ref. No.	Part No.	Qty.	Description
1	1657954	1	CLIP, Center, 5-29/32" long (For Early Models)
	1657553	1	CLIP, Center, 6-31/32" long (For Later Models)
2	1960034	4	SCREW, Plastite, #10-14 x 1/2
3	1656071	1	WIRE ASSY., Headlights
4	932747	1	TIE, Cable
5	927428	1	SCREW, Hex Hd., Taplite, 1/4-20 x 3/8
6	165073	1	CLIP, Speed
7	1651147	1	WIRE ASSY.
8	172996	1	ADAPTOR, 2-Way
9	122184	1	SWITCH, Toggle
10	122182	1	CONNECTOR, Insulated
11	1657955	2	CLIP, Side, 1-14" long (For Early Models)
	1654636	2	CLIP, Side, 1" long (For Later Models)
	1654664	2	REFLECTOR ASSY.
*13		1	BULB, #199
14	1654662	4	GASKET, Lens
15	1665933	2	LENS, Clear Plastic
16	1665934	2	LIGHT ASSY. (Incl. Ref. Nos. 12 - 15)

* Purchase from your local automotive supplier..

Mfg. No. 1691379

Hitch & Lift Kit for Tiller

Ref. No.	Part No.	Qty.	Description
1	1960033	2	HAIR PIN CLIP
2	1701087	1	LIFT ROD
3	1669868	1	ROD GUIDE ASSY.
4	1919262	2	NUT, Hex, Jam, 1/2-20
5	1917372	2	NUT, Hex, 5/16-18 x 1
6	1679225	2	SPACER
7	1917642	2	WASHER, Flat, 5/16
8	1923325	2	BOLT, Hex, 5/16-18 x 7/8
9	1679758	1	HITCH ASSY.
10	931942	3	PUSHNUT
11	1920415	2	CAPSCREW, 3/8-16 x 1-1/4 (Used on early models only. Use existing hardware for later models.)

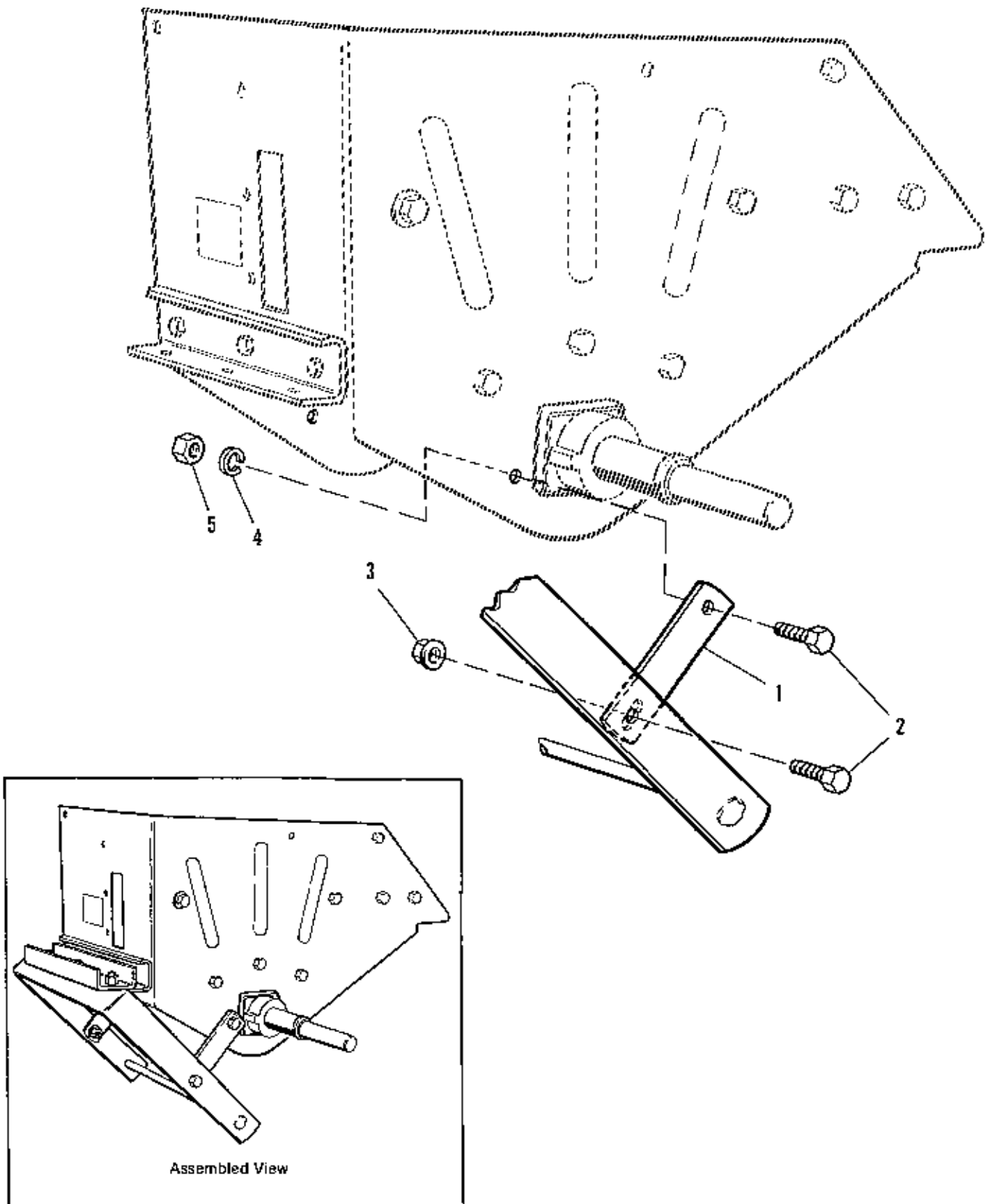

Hitch Brace Kit

Ref. No.	Part No.	Qty.	Description
1	1685201	2	BRACE, Hitch
2	1921210	4	CAPSCREW, Hex Hd., 3/8-16 x 1
3	1930645	2	LOCKNUT, Flange, 3/8-16
4	1916965	2	LOCKWASHER, 3/8
5	1916950	2	NUT, Hex, 3/8-16

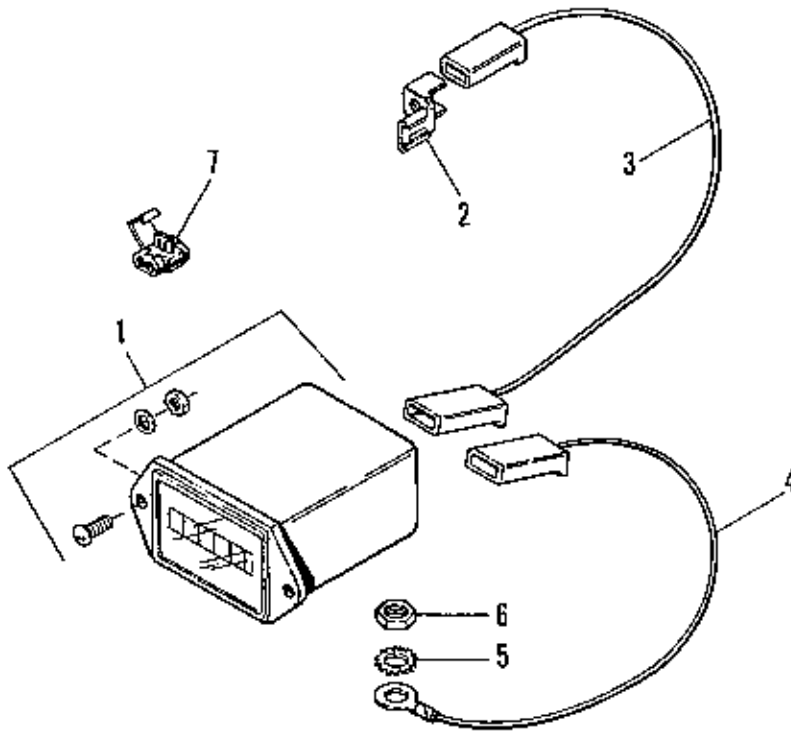

NOTE: Use standard hardware torque spec. chart unless otherwise noted.

Front Counterweight Kit

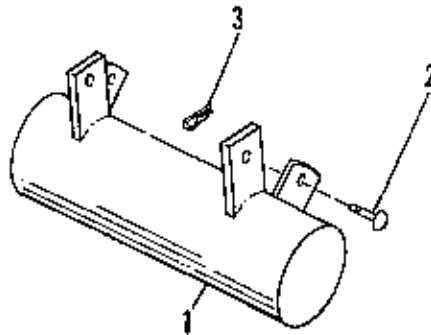

NOTE: Use standard hardware torque spec. chart unless otherwise noted.

Mfg. No. 1685535

Hourmeter Kit

Ref. No.	Part No.	Qty.	Description
1	172993	1	HOURMETER
2	172996	1	ADAPTOR, 2-Way
3	1656083	1	WIRE ASSY.
4	1655592	1	CONNECTOR ASSY., 15-1/2
5	921880	1	LOCKWASHER, Ext. Tooth, 1/4
6	916622	1	NUT, Hex, Full 1/4-20
7	1605751	1	CONNECTOR, Wire, Self-Stripping

Mfg. No. 1690257

Front Counterweight Kit

Ref. No.	Part No.	Qty.	Description
1		1	WEIGHT ASSY., (Order 1690257 from wholegoods.)
2	118053	2	PIN
3	1918196	2	PIN, Quick, 1-7/8

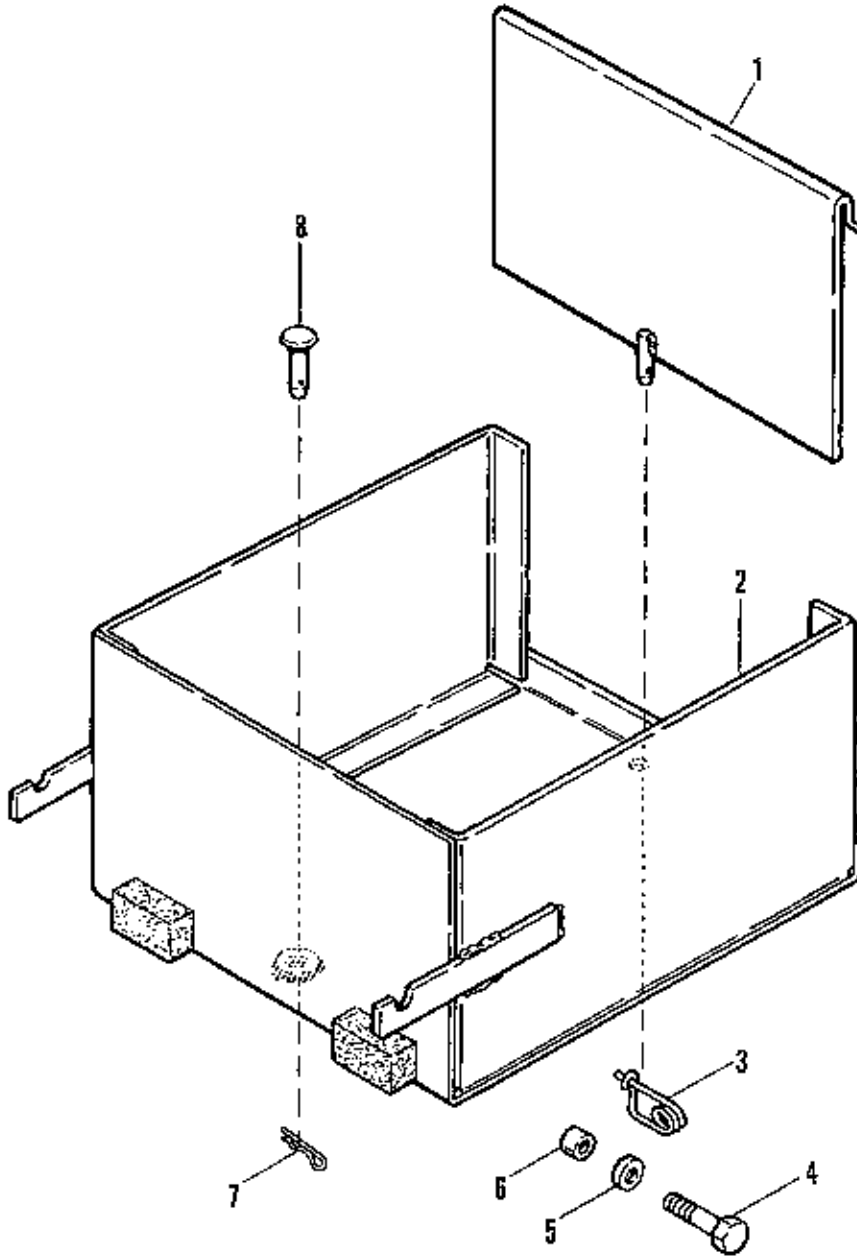

NOTE: Use standard hardware torque spec. chart unless otherwise noted.

Weight Box Group

Ref. No.	Part No.	Qty.	Description
*1		1	DOOR ASSY.
*2		1	WEIGHT BOX ASSY.
3	176012	1	CLIP, Pin, Safety
4	1920415	2	CAPSCREW, 3/8-16 x 1-14
5	1924940	2	WASHER, 3/8
6	158227	2	SPACER
7	1960333	1	CLIP
8	102004	1	PIN, Pivot

*NOTE: To Replace, Order Mfg. No. 1690624

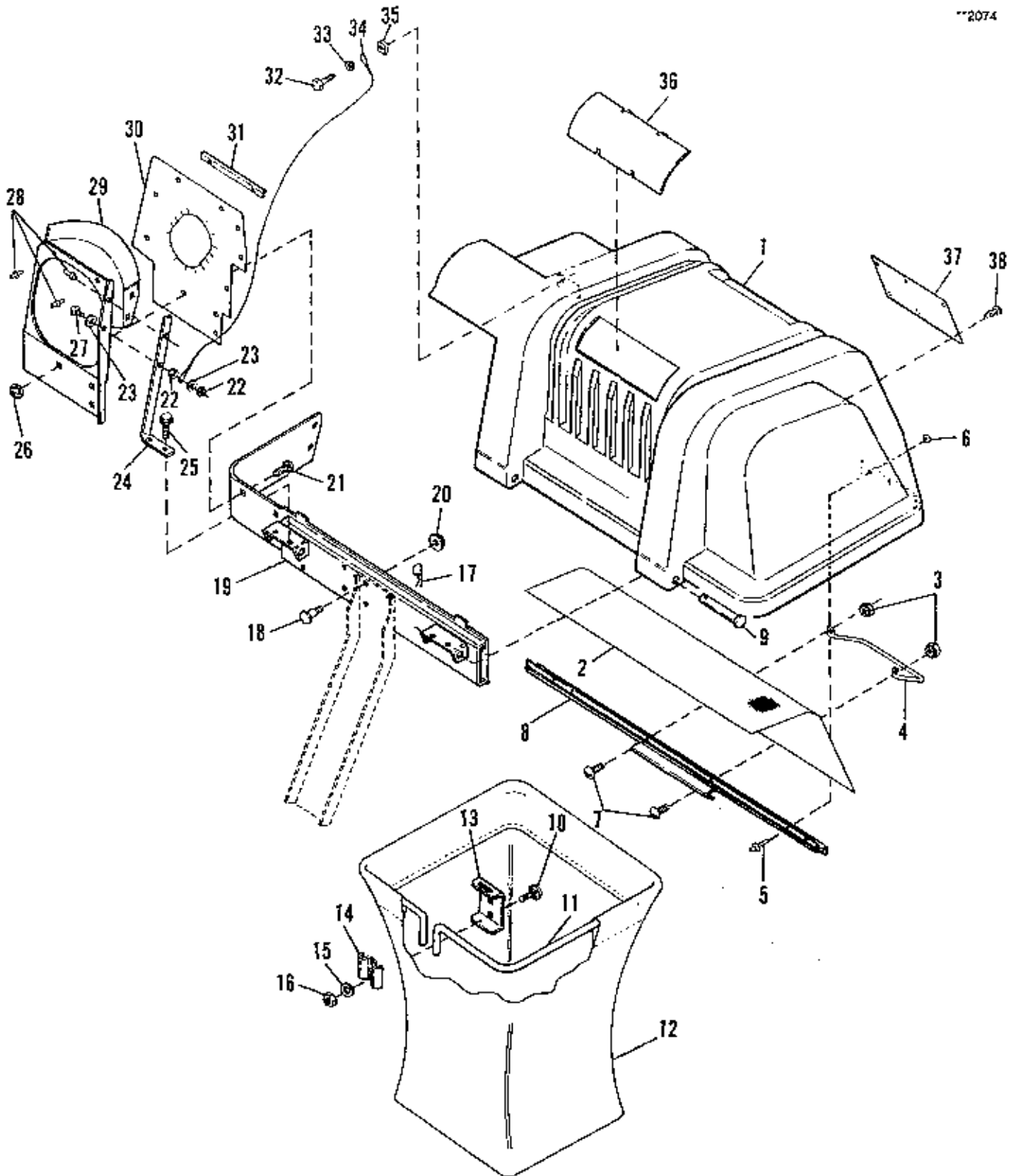

NOTE: Use standard hardware torque spec. chart unless otherwise noted.

Twin Catcher Cover Group

Ref. No.	Part No.	Qty.	Description
1	1704056	1	COVER (Incl. Ref. Nos. 2, 5, 6, 8 & 32-35)
2	1703700	1	SCREEN
3	1928919	2	NUT, Hex, #10-32
4	1703853	1	HANDLE, Latch
5	1675043	4	RIVET, Pop
6	1910531	4	WASHER
7	1930531	2	SCREW, Truss. Hd., #10-32 x 1/2
8	1704057	1	SEAL, Clip
9	960367	2	PIN, Round Head
10	1931333	4	CARRIAGE BOLT, 5/16-18 x 3/4
11	1703855	2	HOOP, Bag
12	1703764	2	BAG, Grass
13	1703807	2	HANGER
14	1672023	2	CLAMP
15	1917356	4	LOCKWASHER, 5/16
16	1917372	4	NUT, Hex, 5/16-18
17	1960221	2	PIN, Hair Clip
18	1921966	4	CAPSCREW, Hex Hd., 3/8-16 x 7/8
19	1703822	1	CROSS ASSY.
20	1928352	4	NUT, Hex, Whizlock, 3/8-16
21	1960252	5	CARRIAGE BOLT, 1/4-20 x 5/8
22	1960077	2	NUT, Hex, Lock, #8-32
23	1960096	2	WASHER
24	1704507	1	STRAP, Tube Support
25	1927428	2	TAPTITE, 1/4-20 x 3/8
26	1930642	5	LOCKNUT, Flange, 1/4-20 End Lock
27	1960399	1	SCREW, Rnd. Hd., #8-32 x 7/8
28	1960381	7	RIVET, Pop
29	1704615	1	SUPPORT, Tube (Incl. Ref. Nos. 22, 23, 24 & 27-31)
30	1704135	1	SEAL, Cover
31	1704508	3	BRACKET SEAL
32	1960400	1	SCREW, Self Tapping, #10-12 x 5/8
33	1917377	1	WASHER, Plain, 1/4
34	1705349	1	CABLE, Double Loop
35	933886	1	NUT, Speed
36	1704180	2	WINDOW
37	1704405	1	DECAL, Safety
38	1667248	6	CLIP, Canoe

SAFETY DECAL

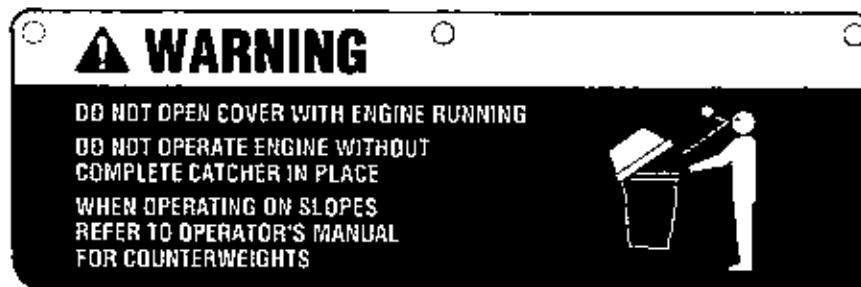

**2173

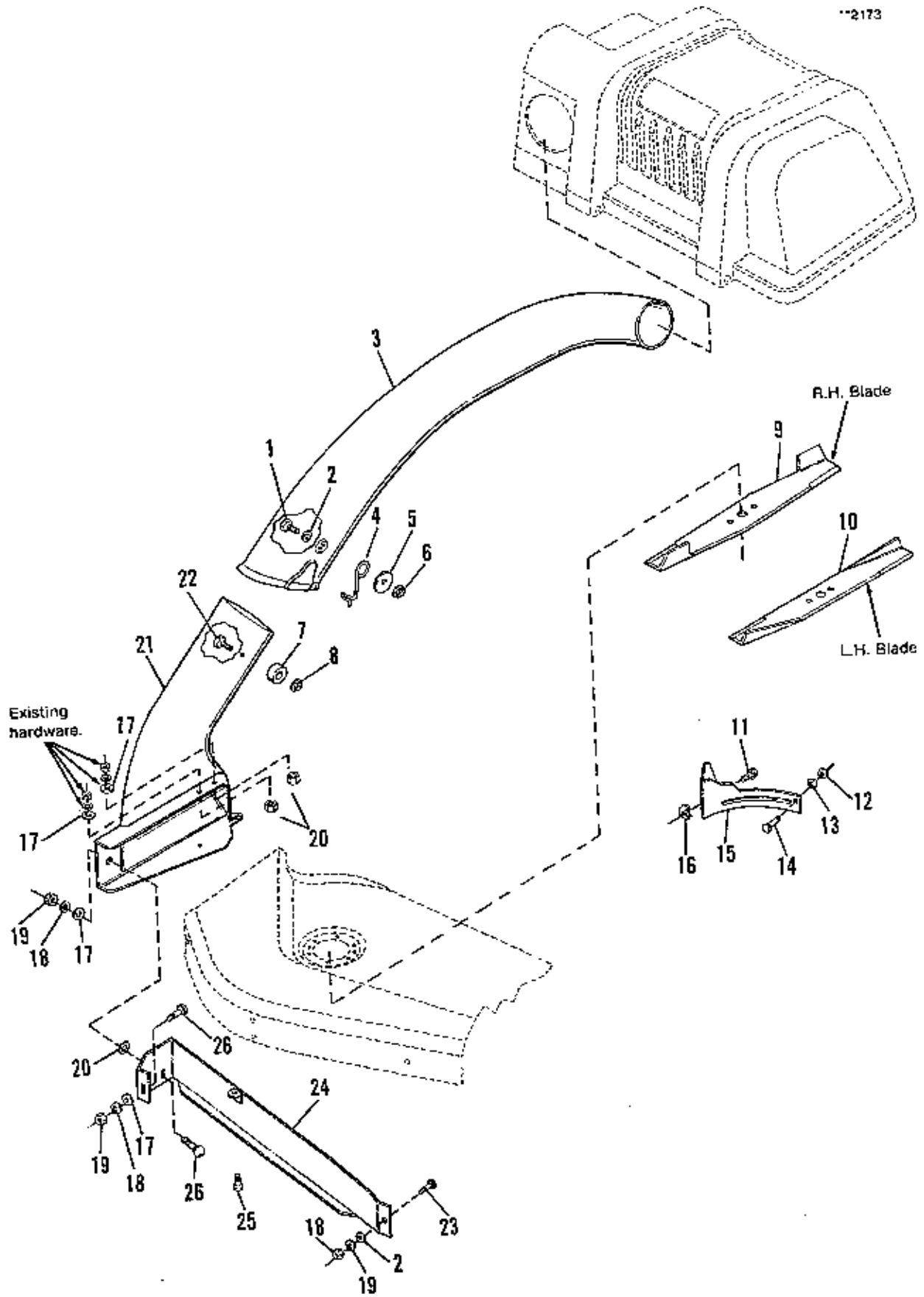

Adapter, Blade & Tube Group

Ref. No.	Part No.	Qty.	Description
1	1960122	1	CAPSCREW, Hex Hd.
2	1919326	2	WASHER, Flat, 5/16
3	1703769	1	TRANSFER TUBE
4	1704603	1	LATCH, Tube
5	1960185	1	WASHER, Flat
6	1935048	1	NUT, Flange Lock
7	1704341	1	WASHER, Special
8	1924433	1	NUT, Esna, Hex Lock, 5/16-18
9	1671565	1	BLADE, R.H. Side
10	1671593	1	BLADE, L.H. Side
11	1931646	1	SCREW, Whizlock, 1/4-20 x 1/2
12	1916622	1	NUT, Hex, 1/4-20
13	1916964	1	Lockwasher, Spring, 1/4
14	1960252	1	CARRIAGE BOLT, 1/4-20 x 5/8
15	1672171	1	BAFFLE, Deflector Side
16	920462	1	NUT, Retainer, 1/4-20
17	1924940	4	WASHER, Flat 3/8
18	1916965	2	WASHER, Spring Lock, 3/8
19	1916950	2	NUT, Hex, 3/8-16
20	931942	3	PUSHNUT
21	1705065	1	ADAPTER, 36" Mower
22	1960371	1	CAPSCREW, Hex Hd., 5/16-18 x 3/4
23	1931334	1	CARRIAGE BOLT, 5/16-18 x 7/8
24	1656053	1	BAFFLE ASSY., Discharge
25	1924856	1	SCREW, Taptite, 5/16-18 x 1/2
26	1931348	2	CARRIAGE BOLT, 3/8-16 x 3/4

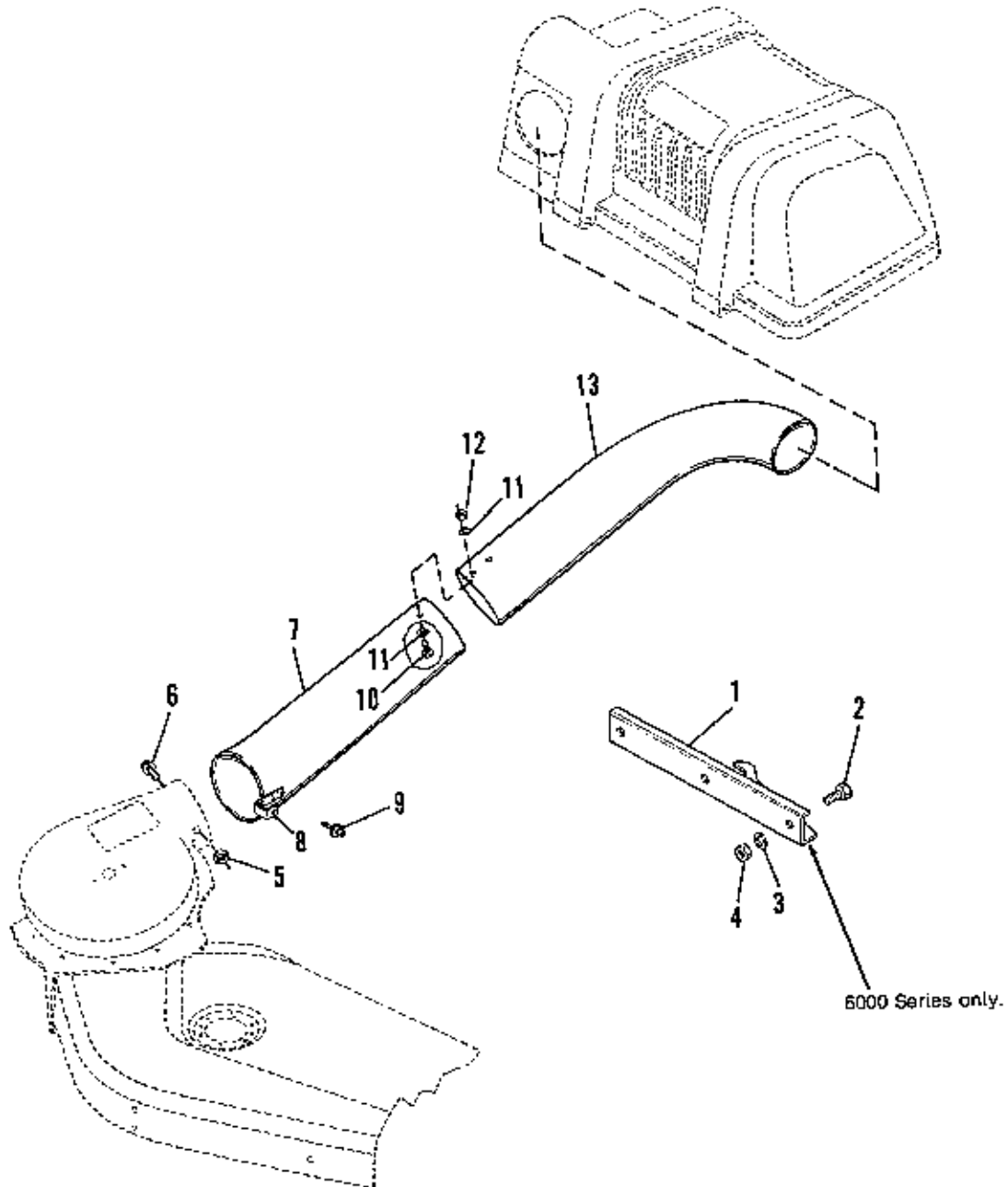

NOTE: Use standard hardware torque spec. chart unless otherwise noted.

Adapter, Blade & Tube Group

Ref. No.	Part No.	Qty.	Description
1	1685200	1	SUPPORT, Attachment (Incl. Ref. Nos. 2, 3, 4)
2	1921210	3	CAPSCREW, Hex Hd., 3/8-16
3	1916965	3	LOCKWASHER, Spring, 3/8
4	1916950	3	NUT, Hex, 3/8-16
5	1930641	1	NUT, Hex, Flange Lock, 1/4-20
6	1960252	1	CARRIAGE BOLT, 1/4-20 x 5/8
7	1705111	1	TUBE ASSY., Lower (Incl. Ref. Nos. 8 & 9)
8	1705063	1	CLIP, Spring
9	1673320	2	RIVER, Pop
10	1930531	2	SCREW, Truss Hd., #10-32 x 1/2
11	1910531	4	WASHER, Plain, #10
12	1926919	2	NUT, Hex Washer Assy., #10-32
13	1704283	1	TUBE, Upper

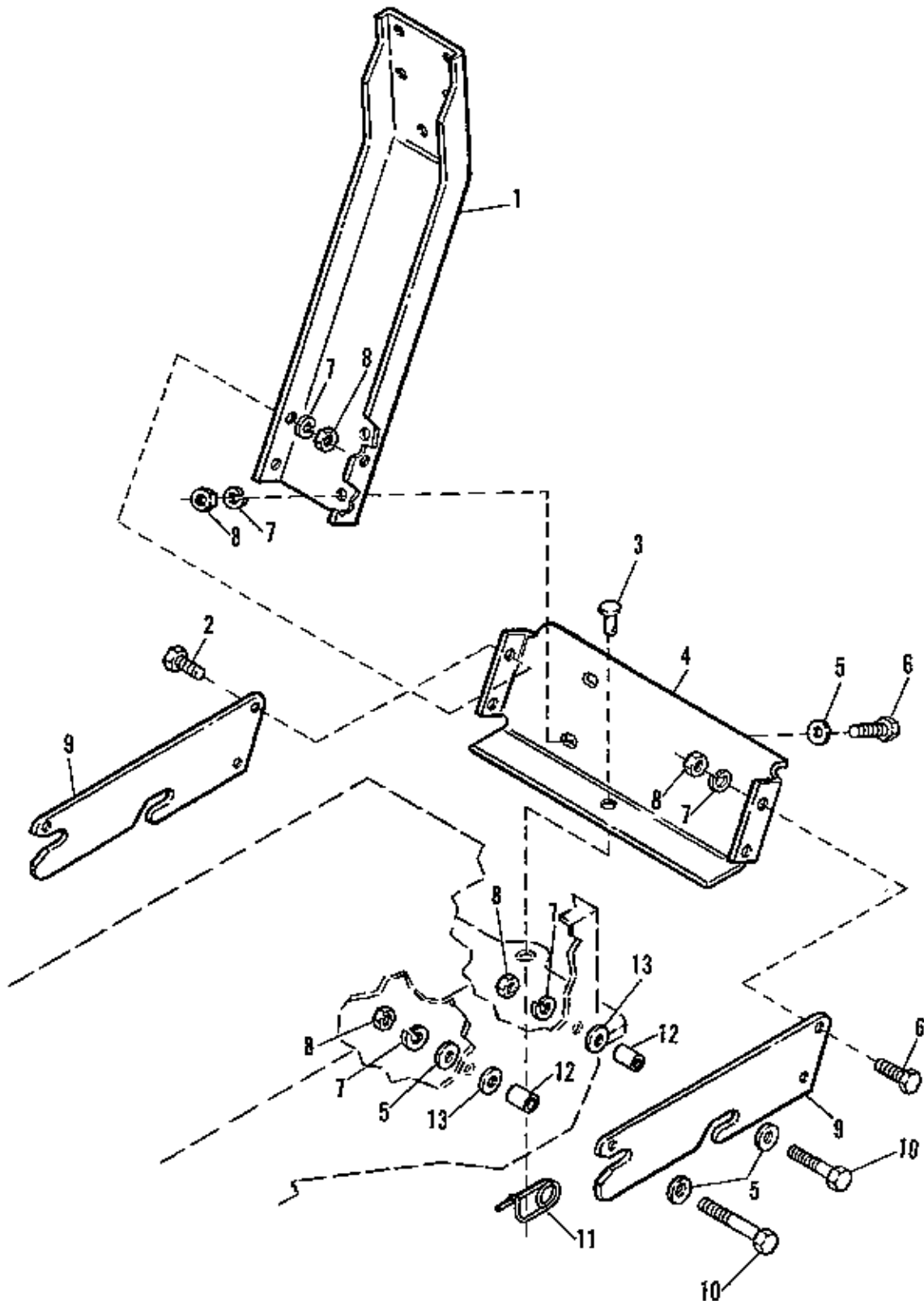

NOTE: Use standard hardware torque spec. chart unless otherwise noted.

Twin Catcher Hitch Group

Ref. No.	Part No.	Qty.	Description
1	1703745	1	SUPPORT, Upright
2	1920415	2	CAPSCREW, Hex, Hd., 3/8-16 x 1-1/4
3	102004	1	PIN, Rd. Hd.
4	1703744	1	BRACKET, Lower Hitch
5	1924940	8	WASHER
6	1921210	4	CAPSCREW, Hex Hd., 3/8-16 x 1
7	1916965	10	LOCKWASHER, Spring, 3/8
8	1916950	10	NUT, Hex, 3/8-16
9	1703743	2	SUPPORT, Side Hitch
10	1921971	4	CAPSCREW, Hex Hd., 3/8-16 x 1-3/4
11	176012	1	CLIP, Safety Pin
12	1865699	4	SPACER
13	1919384	4	WASHER

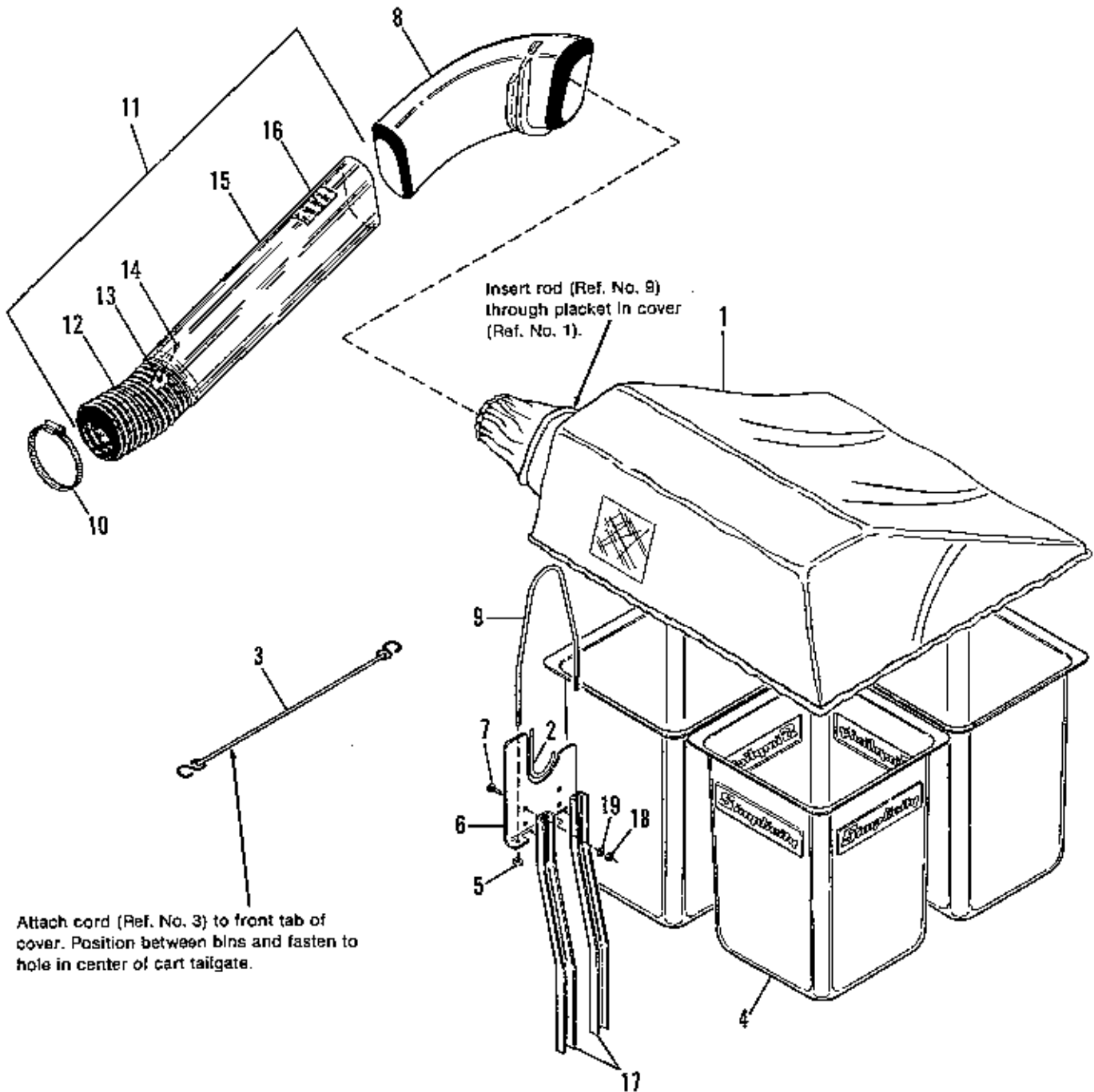

NOTE: Use standard hardware torque spec. chart unless otherwise noted.

Quad Bagger Collection Group

Ref. No.	Part No.	Qty.	Description
1	1702243	1	HOOD
2	1673874	1	TRIM
3	1705282	1	SHOCK CORD
4	1702186	4	BASKET, Grass
5	1923362	2	NUT, Hex, Centerlock, 5/16-18
6	1702827	1	BRACKET, Saddle
7	1960252	4	CARRIAGE BOLT, 1/4-20 x 5/8
8	1702829	1	ELBOW
9	1702829	1	CLAMP, Elbow
10	1679896	1	CLAMP, 6"
11	1704973	1	TUBE ASSY., (Incl. Ref. Nos. 12 - 16)
12	1679895	1	HOSE, 6" I.D.
13	1910531	4	WASHER, Rivet
14	1673320	4	RIVET, Pop
15	1705027	1	TUBE
16	1675766	1	DECAL, Cleaning Instructions
17	1702828	2	CHANNEL, Support
18	1916622	4	NUT, Hex, 1/4-20
19	1916964	4	LOCKWASHER, Spring, 1/4

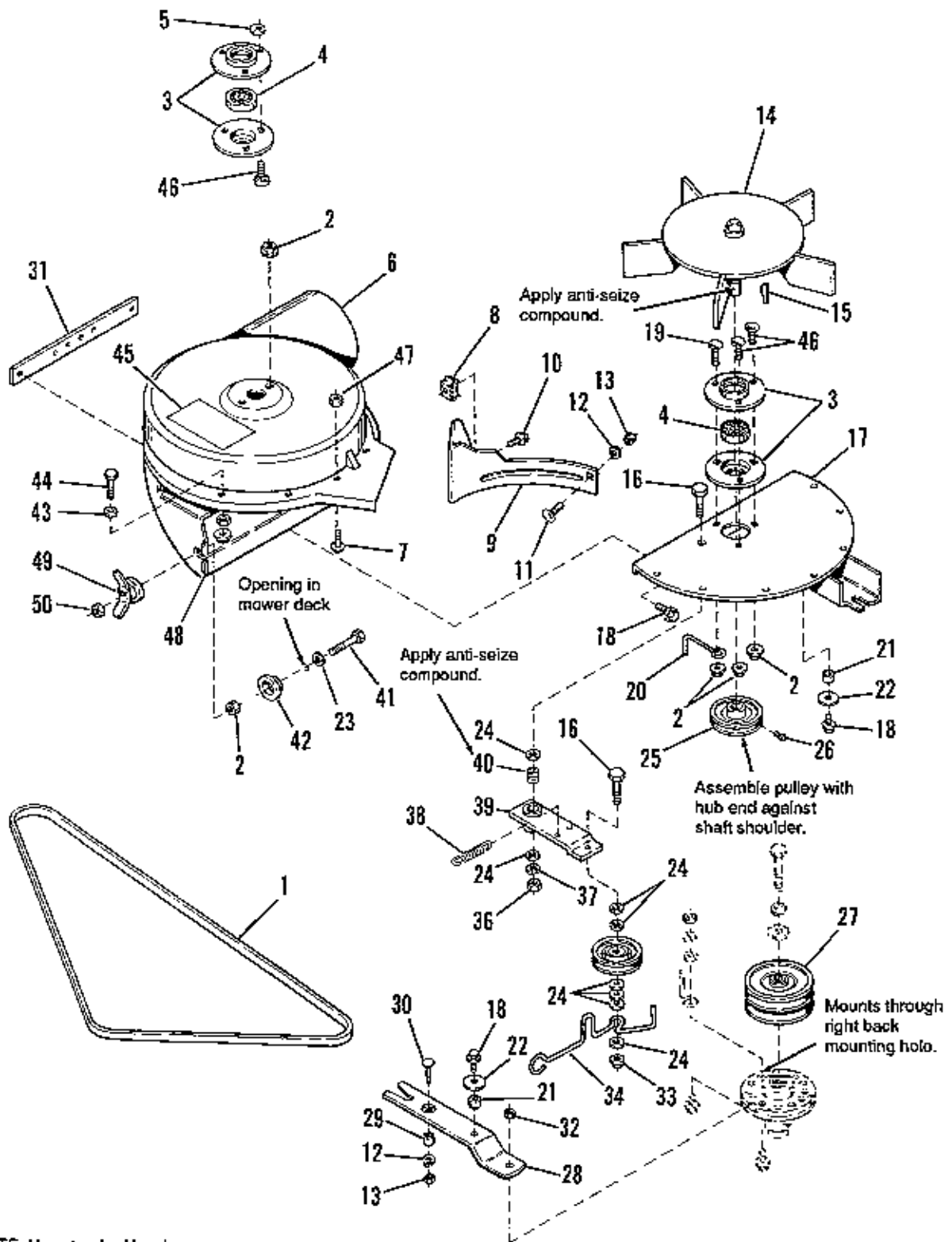

NOTE: Use standard hardware torque spec. chart unless otherwise noted.

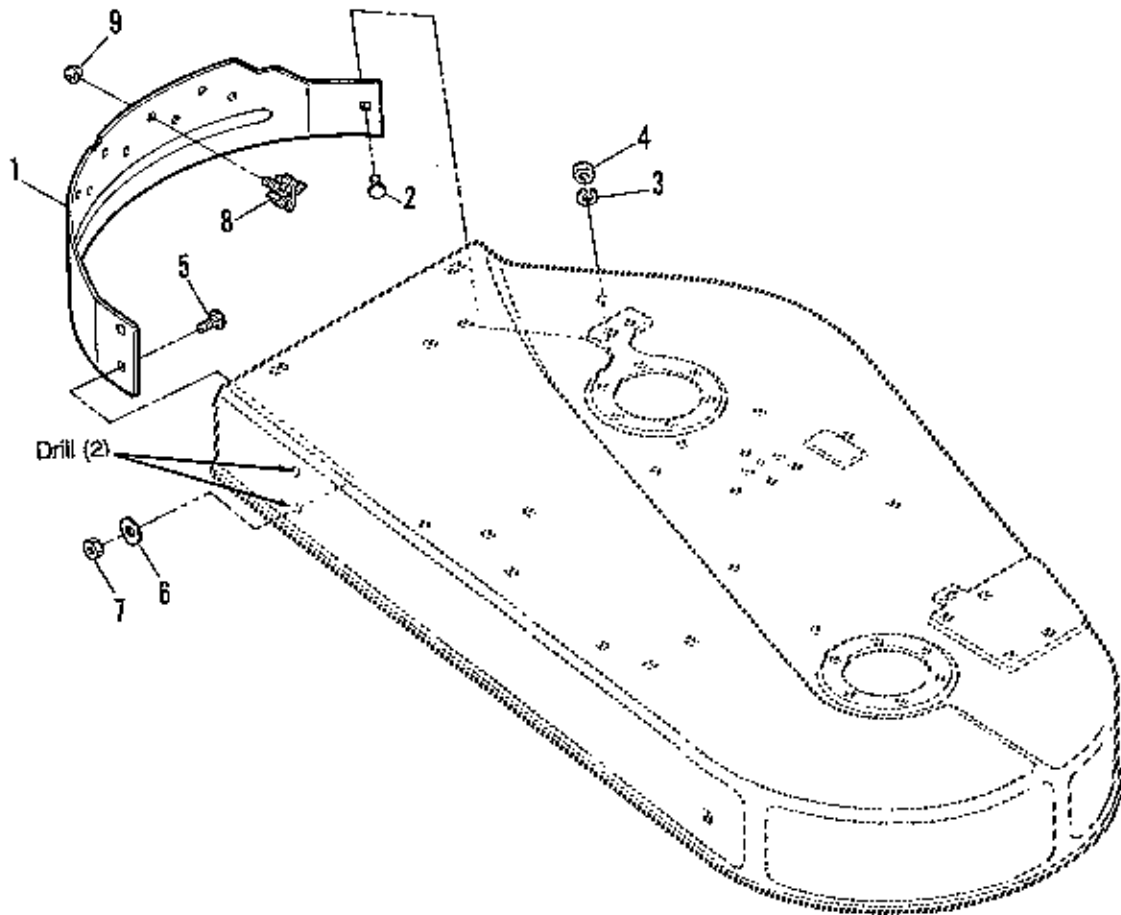

Turbo Collector (36" Mower)

Ref. No.	Part No.	Qty.	Description
1	1679915	1	BELT
2	1927557	7	NUT, Flange Lock, 5/16-18
3	1665982	4	BEARING, Retainer
4	108202	2	BEARING
5	9333988	6	PUSHNUT, 5/16
6	1706623	1	HOUSING ASSY., (incl. Ref. No. 45)
7	1921959	6	CAPSCREW, Hex, 1/4-20 x 5/8
8	920462	1	NUT, Retainer, 14-20
9	1672171	1	BAFFLE
10	1931646	1	SCREW, Whizlock, 1/4-20 x 1/2
11	1960252	1	CARRIAGE BOLT, 1/4-20 x 5/8
12	1916964	2	LOCKWASHER, 1/4
13	1916622	2	NUT, Hex, Full, 1/4-20
14	1706631	1	FAN ASSY.
15	960403	1	KEY, Woodruff
16	1921971	2	CAPSCREW, 3/8-16 x 1-3/4
17	1706628	1	PLATE ASSY.
18	1927429	5	SCREW, Taptite, 1/4-20 x 5/8
19	1931334	1	CARRIAGE BOLT, 5/16-18 x 7/8
20	1678306	1	STOP, Belt
21	1675339	2	SPACER
22	1960151	2	WASHER, Special
23	1919326	1	WASHER, Flat, 5/16
24	1924940	8	WASHER, Flat, 3/8
25	1706634	1	PULLEY, Driven
26	1928691	1	SETSCREW, 5/16-18 x 1/2
27	1700705	1	PULLEY ASSY.
28	1700694	1	STRAP
29	1700695	1	SPACER
30	1931320	1	CARRIAGE BOLT, 1/4-20 x 1-1/4
31	1706630	1	STRIP, Reinforcement
32	1928698	1	NUT, Hex, Jam Lock, 5/16-18
33	1930645	1	NUT, Hex, Flange Lock, 3/8
34	1701095	1	LEVER, Belt, Retainer
35	1708029	1	PULLEY, V
36	1916950	1	NUT, Hex, Full, 3/8-16
37	1916965	1	LOCKWASHER, 3/8
38	1679554	1	SPRING, Tension
39	1700861	1	IDLER ARM ASSY.
40	1666114	1	SPACER
41	1960318	1	CAPSCREW, Hex, 5/16-18 x 2-1/2
42	1679164	1	CUP
43	1921319	1	WASHER, Plain, 1/4
44	1921960	1	CAPSCREW, Hex, 1/4-20 x 1
45	1700259	1	DECAL, Danger
46	1931333	5	CARRIAGE BOLT, 5/16-18 x 3/4
47	1930641	7	LOCKNUT, Hex, Whiz, Flange, 1/4-20
48	1930642	1	NUT, Hex, Flange Lock, 1/4-20
49	1679163	1	WINGNUT ASSY.
50	1923362	1	NUT, Hex, Full, Lock, 5/16-18



Ref. No.	Part No.	Qty.	Description
1	1707992	1	BAFFLE, Discharge
2	1931317	1	CARRIAGE BOLT, 1/4-20 x 3/4"
3	1916964	1	LOCKWASHER, 1/4
4	1916622	1	NUT, Hex, 1/4-20
5	1931333	2	CARRIAGE BOLT, 5/16-18 x 3/4"
6	1917356	2	LOCKWASHER, 5/16
7	1917372	2	NUT, Hex, 5/16-18
8	1707684	8	SHREDDERS, Leaf
9	1919438	8	NUT, Hex, Plastite, 5/16-18

**TORQUE SPECIFICATIONS FOR
STANDARD MACHINE HARDWARE
TOLERANCE $\pm 20\%$**

SIZE	SAE GRADE #2 		SAE GRADE #5 		SAE GRADE #8 	
	<u>In./Lbs.</u> Ft./Lbs.	Nm.	<u>In./Lbs.</u> Ft./Lbs.	Nm.	<u>In./Lbs.</u> Ft./Lbs.	Nm.
8-32	19	2.1	30	3.4	41	4.6
8-36	20	2.3	31	3.5	43	4.9
10-24	27	3.1	43	4.9	60	6.8
10-32	31	3.5	49	5.5	68	7.7
1/4-20	66	7.6	8	10.9	12	16.3
1/4-28	76	8.6	10	13.6	14	19.
5/16-18	11	15.	17	23.1	25	34.
5/16-24	12	16.3	19	25.8	25	34.
3/8-16	20	27.2	30	40.8	45	61.2
3/8-24	23	31.3	35	47.6	50	68.
7/16-14	30	40.8	50	68.	70	95.2
7/16-20	35	47.6	55	74.8	80	108.8
1/2-13	50	68.	75	102.	110	149.6
1/2-20	55	74.8	90	122.4	120	163.2
9/16-12	65	88.4	110	149.6	150	204.
9/16-18	75	102.	120	163.2	170	231.2
5/8-11	90	122.4	150	204.	220	299.2
5/8-18	100	136.	180	244.8	240	326.4
3/4-10	160	217.6	260	353.6	386	525.
3/4-16	180	244.8	300	408.	420	571.2
7/8-9	140	190.4	400	544.	600	816.
7/8-14	155	210.8	440	598.4	660	897.6
1-8	220	299.2	580	788.8	900	1,224.
1-12	240	326.4	640	870.4	1,000	1,360.

NOTE:

- These torque values are to be used for all hardware excluding: locknuts, self-tapping screws, thread forming screws, sheet metal screws and socket head setscrews.
- Recommended seating torque values for locknuts:
 - For prevailing torque locknuts - use 65% of grade 5 torques.
 - For flange whizlock nuts (and screws) - use 135% of grade 5 torques.
- Unless otherwise noted on assembly drawings all torque values must meet this specification.

**BOLT HEAD MARKING
S.A.E. GRADE:**

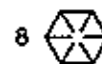
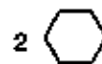

SIMPLICITY MANUFACTURING, INC.
500 N. Spring St., P.O. Box 997
Port Washington, WI USA 53074-0997

TP-1120-03
PRINTED IN U.S.A.
6/93 - CCI