



OPERATOR'S MANUAL



Derby Stallion[™] Zero-Turn Riding Mower

**Model:
ZT2561**

Derby mowers are built by
Ferris Industries, a
Simplicity company.

Ferris Industries
5375 North Main Street
Munnsville, NY 13409
800-933-6175

1822576

Rev. 11/2001
TP 100-7011-03-SL-D

DERBY LIMITED WARRANTY

IMPORTANT

This warranty shall apply ONLY if the warranty registration form has been completed and returned to Ferris Industries, Inc. within 20 days from the date of delivery.

Ferris Industries, Inc. (Ferris) warrants, in accordance with the provisions below, to the original purchaser for the period of twenty-four (24) months, twelve (12) months for commercial use, from the date of delivery of a Derby mower that the mower is free from defects in material or workmanship. Derby's obligation under this warranty is to repair or replace, at Derby's election, without charge and at the place of business of a dealer authorized to handle Derby mowers, any part or parts of the machine which, in the judgment of Derby, prove to be defective.

THIS WARRANTY AND DERBY'S OBLIGATION HEREUNDER IS IN LIEU OF ALL OTHER WARRANTIES, EXPRESSED OR IMPLIED, INCLUDING, WITHOUT LIMITATION, THE IMPLIED WARRANTY OF MERCHANTABILITY OR IMPLIED WARRANTY OF FITNESS FOR PARTICULAR PURPOSE, and all other obligations or liabilities of Derby for incidental and consequential damages resulting from the design, manufacture, sale or use of the machine. No person is authorized to make any warranty or assume for Derby any liability not strictly in accordance with this warranty.

This warranty shall not apply to any mower part which, in the judgment of Derby, has been altered or tampered with in any way or has been subjected to misuse, neglect or accident, or has had the serial numbers altered, effaced or removed. This warranty does not apply to component parts not manufactured by Derby (motors, tires, belts) except to the extent of their individual manufacturer's guarantees.

Ferris Industries, Inc. is continually striving to improve its products, and therefore reserves the right to make improvements or change when it becomes practical and possible to do so, without incurring any obligation to make changes or additions to the equipment sold previously.



Ferris Industries
5375 North Main Street
Munnsville, NY 13409
800-933-6175

www.ferrisindustries.com

© Copyright 2000 Ferris Industries
All Rights Reserved. Printed in USA.



Table of Contents

Identification Numbers	2	Troubleshooting, Adjustments & Service	19
Safety Rules & Information	3	Troubleshooting the Tractor	19
Features & Controls	6	Troubleshooting the Mower	20
Control Functions	6	Seat Adjustment	21
Safety Interlock System	7	Ground Speed Control Lever Adjustment	21
Operating the Tractor	8	Speed Balancing Adjustment	21
General	8	Parking Brake Adjustment	22
Checks Before Starting	8	Suspension Height Adjustment	22
Starting the Engine	9	PTO Clutch Adjustment	23
Stopping the Rider	9	Blade Brake Check	23
Mowing	9	Neutral Adjustment	24
Pushing the Rider by Hand	9	Neutral Spring Return Adjustment	24
Zero Turn Driving Practice	10	Mower Adjustments	25
Storage	12	Cutting Height Adjustment	25
Starting After Long Term Storage	12	Deck Leveling Adjustment	25
Regular Maintenance	14	Hydraulic Pump Drive Belt Replacement	26
Maintenance Schedule	14	Mower Belt Replacement	26
Checking Tire Pressures	14	Battery Service	27
Checking/Adding Fuel	15	Checking the Battery Voltage	27
Fuel Filter	15	Charging A Completely Discharged Battery	27
Oil & Filter Change	15	Jump Starting with	
Check / Change Air Filter	15	Auxiliary (Booster) Battery	27
Check Hydraulic Oil Level	15		
Lubrication	16		
Battery Maintenance	16		
Checking Battery Fluid	16		
Cleaning the Battery and Cables	16		
Servicing the Mower Blades	17		
		Lawn Care & Mowing Information	LC-1
		International Symbols	LC-8
		Technical Manuals	LC-8

NOTE: In this manual, "left" and "right" are referred to as seen from the operating position.

WARNING

Engine exhaust from this product contains chemicals known, in certain quantities, to cause cancer, birth defects, or other reproductive harm.

Identification Numbers



IDENTIFICATION TAG LOCATIONS

When contacting your Authorized Dealer for replacement parts, service, or information **YOU MUST HAVE THESE NUMBERS.**



IDENTIFICATION NUMBERS

Record your model name, unit and mower deck serial numbers and engine serial number in the space provided for easy reference.

- The **Tractor I.D. tag** is located on the inside of the main frame rail, behind the deck height plate.
- For location of **Engine Serial Number**, refer to the Engine Owner's Manual.

Be sure to fill out and return the Warranty Registration Card supplied with your unit.

PRODUCT REFERENCE DATA	
Model Description Name	
Unit MODEL Number	Unit SERIAL Number
Mower Deck MODEL Number N/A	Mower Deck SERIAL Number N/A
Dealer Name	Date Purchased
ENGINE REFERENCE DATA	
Engine Make/Model	Engine ID/Serial Number



Safety Rules & Information



Read these safety rules and follow them closely. Failure to obey these rules could result in loss of control of unit, severe personal injury or death to you, or bystanders, or damage to property or equipment. **This mowing deck is capable of amputating hands and feet and throwing objects.** The triangle in text signifies important cautions or warnings which must be followed.

GENERAL OPERATION

- Read, understand, and follow all instructions in the manual and on the unit before starting.
- Only allow responsible adults, who are familiar with the instructions, to operate the unit.
- Clear the area of objects such as rocks, toys, wire, etc., which could be picked up and thrown by the blade(s).
- Be sure the area is clear of other people before mowing. Stop unit if anyone enters the area.
- Never carry passengers.
- Do not mow in reverse unless absolutely necessary. Always look down and behind before and while travelling in reverse.
- Be aware of the mower discharge direction and do not point it at anyone. Do not operate the mower without either the entire grass catcher or the deflector in place.
- Slow down before turning.
- Never leave a running unit unattended. Always disengage the PTO, set parking brake, stop engine, and remove keys before dismounting.
- Turn off the PTO switch to disengage the blades when not mowing.
- Stop engine before removing grass catcher or unclogging chute.
- Mow only in daylight or good artificial light.
- Do not operate the unit while under the influence of alcohol or drugs.
- Watch for traffic when operating near or crossing roadways.
- Use extra care when loading or unloading the unit into a trailer or truck.
- Data indicates that operators, age 60 years and above, are involved in a large percentage of riding mower-related injuries. These operators should evaluate their ability to operate the riding mower safely enough to protect themselves and others from serious injury.

WARNING

Never operate on slopes greater than 30 percent (16.7°) which is a rise of three feet vertically in 10 feet horizontally.

Select slow ground speed before driving onto slope. Use extra caution when operating on slopes with rear-mounted grass catcher.

Mow UP and DOWN the slope, never across the face, use caution when changing directions and DO NOT START OR STOP ON SLOPE.

SLOPE OPERATION

Slopes are a major factor related to loss-of-control and tip-over accidents, which can result in severe injury or death. **All slopes require extra caution. If you cannot back up the slope or if you feel uneasy on it, do not drive on it**

Do

- See your authorized dealer for recommendations of available weights to improve stability.
- Mow up and down slopes, not across.
- Remove obstacles such as rocks, tree limbs, etc.
- Watch for holes, ruts, or bumps. Uneven terrain could overturn the unit. Tall grass can hide obstacles.
- Use slow speed. Choose a low gear so that you will not have to stop or shift while on the slope.
- Use extra care with grass catchers or other attachments. These can change the stability of the unit.
- Keep all movement on the slopes slow and gradual. Do not make sudden changes in speed or direction.

Do Not

- *Do not* start or stop on a slope. If tires lose traction, disengage the blade(s) and proceed slowly straight down the slope.
- *Do not* turn on slopes unless necessary, and then, turn slowly and gradually uphill, if possible.
- *Do not* mow near drop-offs, ditches, or embankments. The mower could suddenly turn over if a wheel is over the edge of a cliff or ditch, or if an edge caves in.
- *Do not* mow on wet grass. Reduced traction could cause sliding.
- *Do not* try to stabilize the unit by putting your foot on the ground.
- *Do not* use grass catcher on steep slopes.

Safety Rules & Information

CHILDREN

Tragic accidents can occur if the operator is not alert to the presence of children. Children are often attracted to the unit and the mowing activity. Never assume that children will remain where you last saw them.

- Keep children out of the mowing area and under the watchful care of another responsible adult.
- Be alert and turn unit off if children enter the area.
- Before and during reverse operation, look behind and down for small children.
- Never carry children. They may fall off and be seriously injured or interfere with safe unit operation.
- Never allow children to operate the unit.
- Use extra care when approaching blind corners, shrubs, trees, or other objects that may obscure vision.

TRANSPORTING AND STORAGE

- Always observe safe refueling and fuel handling practices when refueling the unit after transportation or storage.
- Always follow the engine manual instructions for storage preparations before storing the unit for both short and long term periods.
- Always follow the engine manual instructions for proper start-up procedures when returning the unit to service.
- Never store the unit or fuel container inside where there is an open flame or pilot light, such as in a water heater. Allow unit to cool before storing.

SERVICE AND MAINTENANCE

- Use extra care when handling gasoline and other fuels. They are flammable and vapors are explosive.
 - a) Use only an approved container.
 - b) Never remove fuel cap or add fuel with the engine running. Allow engine to cool before refueling. Do not smoke.
 - c) Never refuel the unit indoors.

- Never run a unit in an enclosed area.
- Keep nuts and bolts, especially blade attachment bolts, tight and keep equipment in good condition.
- Never tamper with safety devices. Check their proper operation regularly.
- Keep unit free of grass, leaves, or other debris build-up. Clean up oil or fuel spillage.
- Stop and inspect the equipment if you strike an object. Repair, if necessary, before restarting.
- Never make adjustments or repairs with the engine running unless specified otherwise in the engine manufacturer's manual.
- Grass catcher components are subject to wear, damage, and deterioration, which could expose moving parts or allow objects to be thrown. Frequently check components and replace with manufacturer's recommended parts, when necessary.
- Mower blades are sharp and can cut. Wrap the blade(s) or wear gloves, and use extra caution when servicing them.
- Check brake operation frequently. Adjust and service as required.
- Use only factory authorized replacement parts when making repairs.
- Always comply with factory specifications on all settings and adjustments.
- Only authorized service locations should be utilized for major service and repair requirements.
- Never attempt to make major repairs on this unit unless you have been properly trained. Improper service procedures can result in hazardous operation, equipment damage and voiding of manufacturer's warranty.

SAFETY DECALS

This unit has been designed and manufactured to provide you with the safety and reliability you would expect from an industry leader in outdoor power equipment manufacturing.

Although reading this manual and the safety instructions it contains will provide you with the necessary basic knowledge to operate this equipment safely and effectively, we have placed several safety labels on the unit to remind you of this important information while you are operating your unit.

All DANGER, WARNING, CAUTION and instructional messages on your rider and mower should be carefully read and obeyed. Personal bodily injury can result when these instructions are not followed. The information is for your safety and it is important! The safety decals below are on your rider and mower.

If any of these decals are lost or damaged, replace them at once. See your local dealer for replacements.

These labels are easily applied and will act as a constant visual reminder to you, and others who may use the equipment, to follow the safety instructions necessary for safe, effective operation.



Decal - Warning/Danger
Part No. 45560

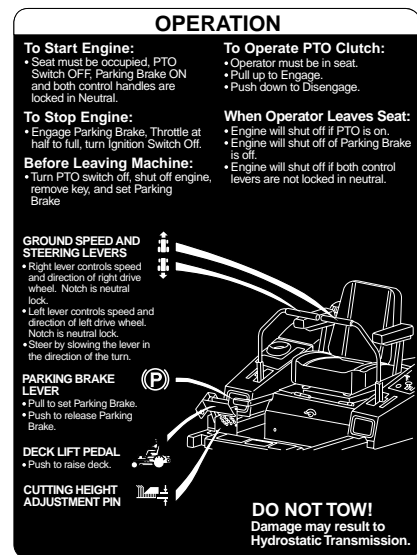

Decal - Operation & Controls
Part No. 45559

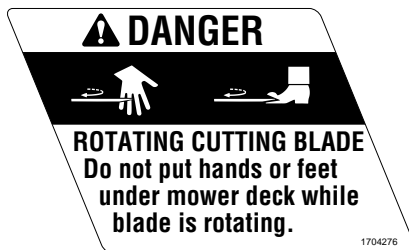

Decal - Danger
Part No. 1704276



Decal - Danger
Part No. 1704277



Decal - Danger
Part No. 22143



Decal - Caution
Part No. 46481

Features & Controls of the Zero Turn Rider



Please take a moment and familiarize yourself with the name, location, and function of these controls so that you will better understand the safety and operating instructions provided in this manual.

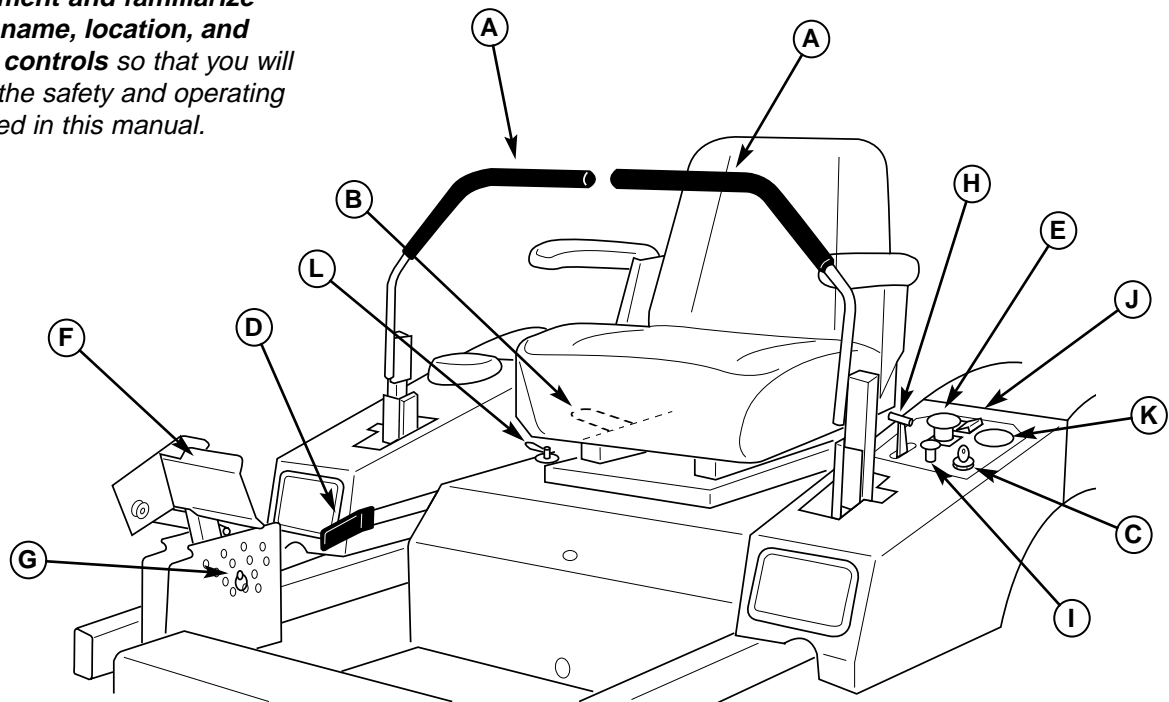

Figure 1. Control Locations

CONTROL FUNCTIONS

The information below briefly describes the function of individual controls. Starting, stopping, driving, and mowing require the combined use of several controls applied in specific sequences. To learn what combination and sequence of controls to use for various tasks see the OPERATION section.

A. Ground Speed Control Levers

These levers control the ground speed of the rider. The left lever controls the left rear drive wheel and the right controls the right rear drive wheel.

Moving a lever forward increases the FORWARD speed of the associated wheel, and pulling back on a lever increases the REVERSE speed.

Note: The further a lever is moved away from the neutral position the faster the drive wheel will turn.

See the Operating the Zero Turn Rider section for steering instructions.

B. Seat Adjustment Lever

The seat can be adjusted forward and back. Move the lever forward, position the seat as desired, and release the lever to lock the seat in position.

C. Ignition Switch

The ignition switch starts and stops the engine, it has three positions:

- OFF Stops the engine and shuts off the electrical system.
- RUN Allows the engine to run and powers the electrical system.
- START Cranks the engine for starting.

NOTE: Never leave the ignition switch in the RUN position with the engine stopped—this drains the battery.

D. Parking Brake Handle

The parking brake is applied by pulling UP on the parking brake handle until it locks over-center. To release the parking brake, push the handle DOWN.

E. PTO (Power Take Off) Switch

The PTO switch engages and disengages the mower. Pull UP on the switch to engage, and push DOWN to disengage.

F & G. Deck Lift Pedal & Cutting Height Adjustment Pin

These control the cutting height of the mower deck.

Depress the pedal until it locks into the TRANSPORT position. Place the adjustment pin in the desired cutting height and release the lift pedal.

H & I. Throttle / Choke Control

Pulling the round choke control knob (I) out fully chokes the engine for cold starts. (A warm engine may not require choking.) Moving the throttle control (H) fully forward is FULL throttle position. Always operate the unit at FULL throttle when mowing.

J. Headlight Switch

Turn the switch ON to light the front headlight.

K. Hour Meter

Measures the time of the PTO being engaged.

L. Fuel Shut Off Valve

Turning the handle to the desired position determines which tank will be supplying fuel. With the handle pointing forward, it will draw fuel from the left-hand tank. With the handle pointed towards the rear, it will draw fuel from the right-hand fuel tank. With the handle pointing towards the right, it will shut off fuel flow to the engine.



SAFETY INTERLOCK SYSTEM

This unit is equipped with safety interlock switches and other safety devices. These safety systems are present for your safety, do not attempt to bypass safety switches, and never tamper with safety devices. Check their operation regularly.

Operational SAFETY Checks

Your unit is equipped with a seat switch safety system. Check the seat switch operation every fall and spring with the following tests.

Test 1 — Engine should NOT crank if:

- PTO switch is engaged, OR
- Parking brake is not engaged, OR
- Motion control handles are not in the NEUTRAL position, OR
- Operator is not on the seat.

Test 2 — Engine SHOULD crank if:

- PTO switch is NOT engaged, AND
- Parking brake is engaged, AND
- Motion control handles are locked in the NEUTRAL position, AND
- Operator is on the seat.

Test 3 — Engine should SHUT OFF if:

- Operator rises off seat with PTO engaged, OR
- Operator rises off seat with parking brake disengaged.

Test 4 — Blade Brake Check

Mower blades and mower drive belt should come to a complete stop within five seconds after electric PTO switch is turned off (or operator rises off seat). If mower drive belt does not stop within five seconds, see your dealer.

NOTE: Once the engine has stopped, PTO switch must be turned off, parking brake must be engaged, and the motion control handles must be locked in the NEUTRAL position after the operator returns to the seat in order to start the engine.

WARNING

If the unit does not pass a safety test, do not operate it. See your authorized dealer. Under no circumstance should you attempt to defeat the purpose of the safety interlock system.

Operating the Zero Turn Rider



GENERAL OPERATING SAFETY

Before first time operation:

- Be sure to read all information in the Safety and Operation sections before attempting to operate this tractor and mower.
- Become familiar with all of the controls and how to stop the unit.
- Drive in an open area without mowing to become accustomed to the unit. brake pedal or set the parking brake.

CHECKS BEFORE STARTING

- Check that crankcase is filled to full mark on dipstick. See the engine Operator's Manual for instructions and oil recommendations.
- Make sure all nuts, bolts, screws and pins are in place and tight.
- Adjust the seat position, and make certain you can reach all controls from operator's position.
- Fill the fuel tank with fresh fuel. Refer to engine manual for fuel recommendations.

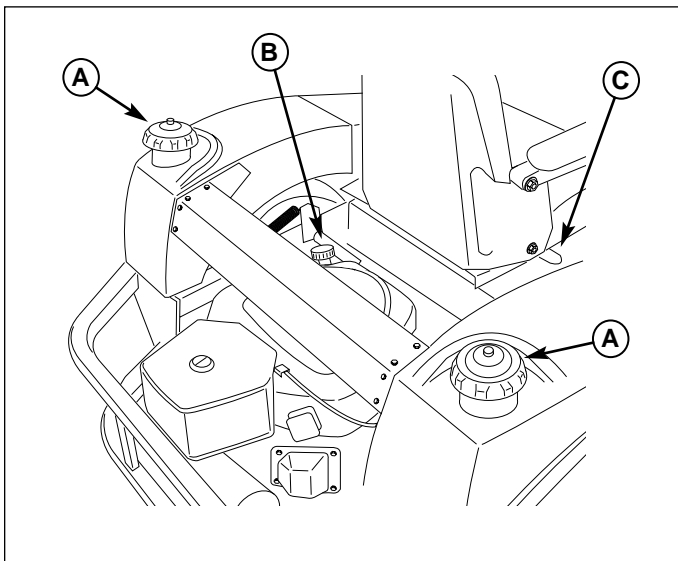

Figure 2. Pre-start Checks

- A. Fuel Tank Filler Neck
- B. Crankcase Oil Fill
- C. Seat Adjustment Lever

! WARNING

Never allow passengers to ride on the unit.

Before leaving the operator's position for any reason, engage the parking brake, disengage the PTO, stop the engine and remove the key.

To reduce fire hazard, keep the engine, tractor and mower free of grass, leaves and excess grease. Do not stop or park tractor over dry leaves, grass or combustible materials.

Gasoline is highly flammable and must be handled with care. Never fill the tank when the engine is still hot from recent operation. Do not allow open flame, smoking or matches in the area. Avoid over-filling and wipe up any spills.

! DANGER

OPERATING ON SLOPES CAN BE DANGEROUS

Never operate on slopes greater than 30 percent (16.7°) which is a rise of three feet vertically in 10 feet horizontally.

Operate the unit at a slow ground speed when driving onto slope.

Use extra caution when operating on slopes with rear-mounted grass catcher. Mow UP and DOWN the slope, never across the face, use caution when changing directions and **DO NOT START OR STOP ON SLOPE.**

⚠️ WARNING

If you do not understand how a specific control functions, or have not yet thoroughly read the **FEATURES & CONTROLS** section, do so now.

Do **NOT** attempt to operate the tractor without first becoming familiar with the location and function of **ALL** controls.

STARTING THE ENGINE

1. While sitting in the operator's seat, engage the parking brake and make sure the PTO switch is disengaged and the motion control handles are locked in the NEUTRAL position.
2. **NOTE: A warm engine may not require choking.**
Set the engine throttle control (H, Figure 1) to FAST throttle position. Then fully close the choke (I, Figure 1) by pulling the knob OUT fully.
3. Insert the key into the ignition switch (K, Figure 1) and turn it to START.
4. After the engine starts, gradually open the choke (push knob down fully).

Warm up the engine by running it for at least a minute before engaging the PTO switch or driving the rider.

5. **After warming the engine, ALWAYS operate the unit at FULL THROTTLE when mowing.**

In the event of an emergency the engine can be stopped by simply turning the ignition switch to STOP. Use this method only in emergency situations. For normal engine shut down follow the procedure given in **STOPPING THE RIDER**.

STOPPING THE RIDER

1. Returning the ground speed control levers (A, Figure 1) to the middle position will stop tractor movement. Pivot the levers outward and lock them in NEUTRAL.
2. Disengage the PTO by pushing down on the PTO switch (E, Figure 1).
3. Engage the parking brake by pulling the handle (D, Figure 1) up until it locks into position.
4. Move the throttle control (H, Figure 1) to mid-throttle position and turn the ignition key to OFF. Remove the key.

MOWING

1. Engage the parking brake. Make sure the PTO switch is disengaged, the motion control handles are locked in the NEUTRAL position and the operator is on the seat.
2. Start the engine (see **STARTING THE ENGINE**).
3. Set the mower cutting height.
4. Set the throttle to FULL.
5. Engage the PTO by pulling up on the PTO switch (E, Figure 1).
6. Begin mowing. See Section C for tips on mowing patterns, lawn care, and trouble shooting information.
7. When finished, shut off the PTO.
8. Stop the engine (see **STOPPING THE TRACTOR AND ENGINE**).

PUSHING THE RIDER BY HAND



DO NOT TOW RIDER

Towing the unit will cause hydraulic pump and wheel motor damage. Do not use another vehicle to push or pull this unit.

1. Disengage the PTO, engage the parking brake, turn the ignition OFF, and remove the key.
2. Lift the seat plate to gain access to the battery compartment and hydraulic pumps.
3. To disengage the pumps (free-wheel position), turn the hydraulic release valves (A, Figure 3) located on the pumps **COUNTER-CLOCKWISE** a maximum of 2 full turns.
4. Disengage the parking brake.
The tractor can now be pushed by hand.
5. After moving the tractor, re-engage the pumps (drive position) by turning the release valves **CLOCKWISE** and tighten to 80-120 in. lbs. of torque.

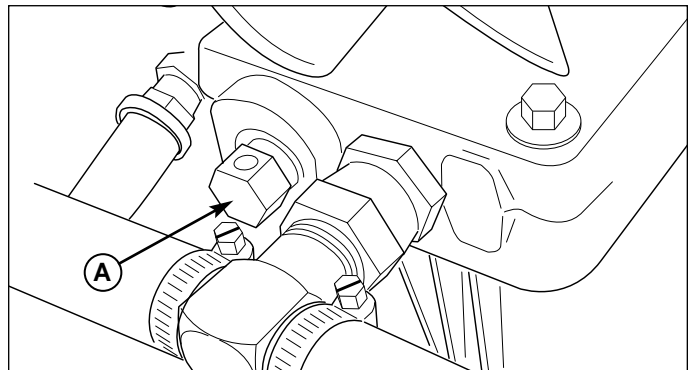

Figure 3. Hydraulic System By-Pass

A. Hydraulic Release Valve (right-hand pump shown)

Operating the Zero Turn Rider

ZERO TURN DRIVING PRACTICE

The lever controls of the Zero Turn rider are *responsive*, and learning to gain a *smooth* and *efficient* control of the rider's forward, reverse, and turning movements will take some practice.

Spending some time going through the maneuvers shown and becoming familiar with how the unit accelerates, travels, and steers — before you begin mowing — is absolutely essential to getting the most out of the Zero Turn rider.

Locate a smooth, flat area of your lawn — one with plenty of room to maneuver. (Clear the area of objects, people and animals before you begin.) Operate the unit at mid-throttle during this practice session (ALWAYS operate at full throttle when mowing), and turn slowly to prevent tire slippage and damage to your lawn.

We suggest you begin with the **Smooth Travel** procedure to the right, and then advance through the forward, reverse, and turning maneuvers.

You must release the parking brake prior to moving the control levers inward.

Smooth Travel

The lever controls of the Zero Turn rider are **RESPONSIVE**.

The BEST method of handling the ground speed control levers is in three steps — as shown in Figure 4.

FIRST place your hands onto the levers as shown.

SECOND, to go forward gradually push the levers forward with your palms.

THIRD, to speed up move the levers farther forward. To slow down smoothly, slowly move the levers toward neutral.

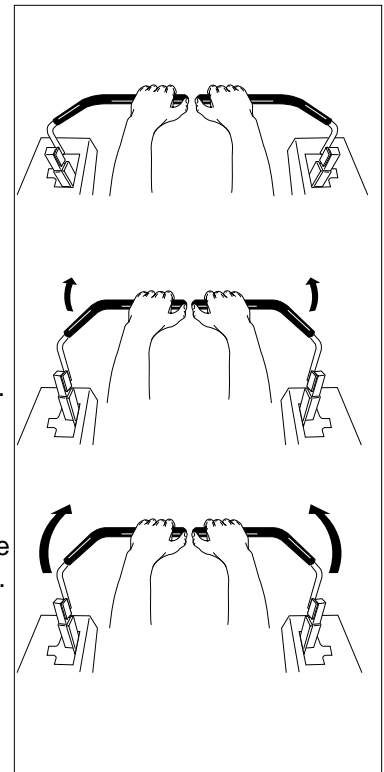

Figure 4. Move Control Levers Gradually

BASIC DRIVING

Forward Travel Practice

Gradually move both ground speed control levers — evenly FORWARD from neutral. Slow down and repeat.

NOTE: Straight forward travel takes practice. If necessary, top speed can be balance-adjusted — see the Speed Balancing Adjustment in the Adjustments section near the back of this manual.

Reverse Travel Practice

LOOK DOWN & BEHIND, then gradually move both ground speed control levers evenly BACK from neutral. Slow down and repeat.

NOTE: Practice backing up for several minutes before attempting to do so near objects. The rider turns sharply in reverse as well as forward, and backing up straight takes practice.

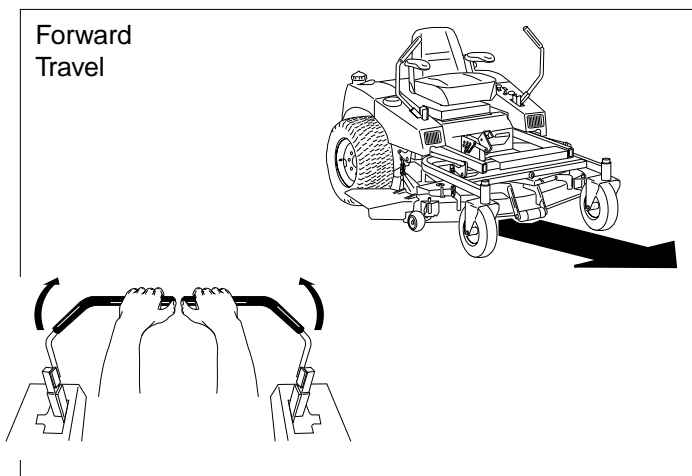

Figure 5. Forward Travel

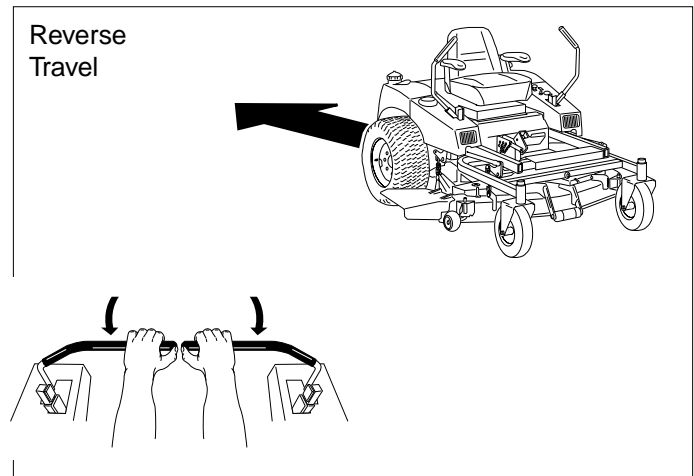

Figure 6. Reverse Travel

Practice Turning Around a Corner

While traveling forward allow one handle to gradually return back toward neutral. Repeat several times.

NOTE: To prevent pivoting directly on the tire tread, it is best to keep both wheels going at least slightly forward.

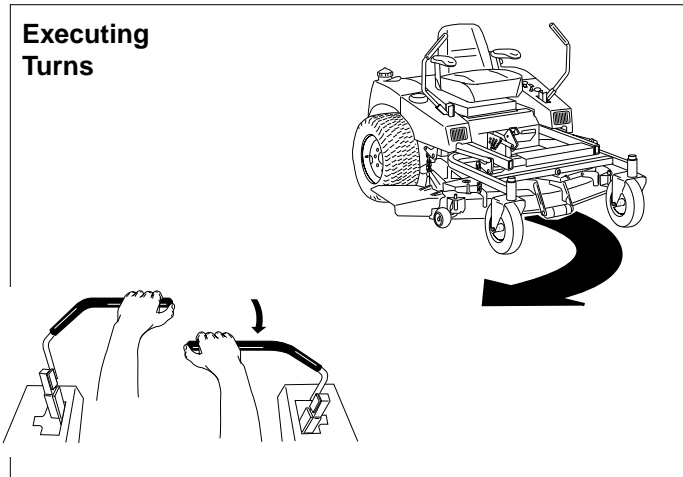

Figure 7. Turning Around a Corner

Practice Turning In Place

To turn in place, “Zero Turn,” gradually move one ground speed control lever forward from neutral and one lever back from neutral simultaneously. Repeat several times.

NOTE: Changing the amount each lever is pulled—forward or back, changes the “pivot point” you turn on.

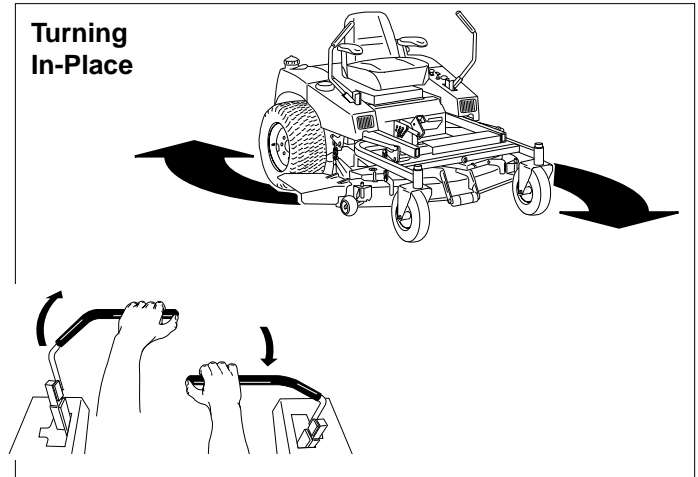

Figure 8. Turning in Place

ADVANCED DRIVING

Executing an End-Of-Row Zero Turn

Your Zero Turn Rider’s unique ability to turn in place allows you to turn around at the end of a cutting row rather than having to stop and Y-turn before starting a new row.

For example, to execute a right end-of row Zero Turn:

1. Slow down at the end of the row.
2. Move the LEFT ground speed control lever forward slightly while moving the RIGHT ground speed control lever back to center and then slightly back from center.
3. Begin mowing forward again.

This technique turns the rider RIGHT and slightly overlaps the row just cut —eliminating the need to back up and re-cut missed grass.

As you become more familiar and experienced with operating the Zero Turn rider, you will learn more maneuvers that will make your mowing time easier and more enjoyable.

Remember, the more you practice, the better your control of the Zero Turn will be!

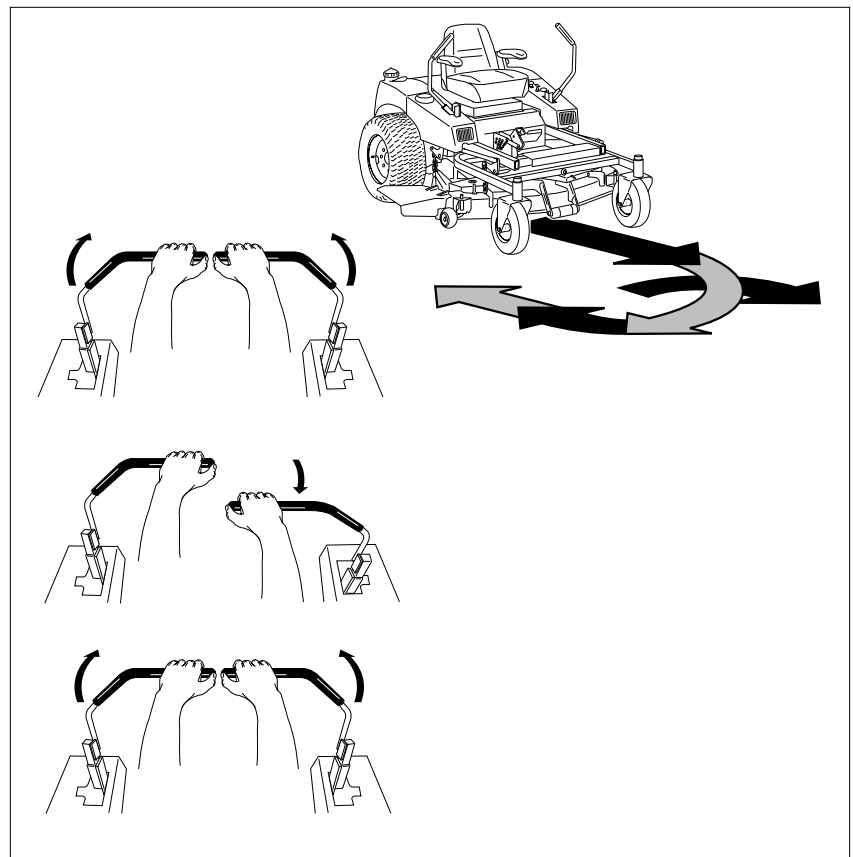

Figure 9. Executing an End-Of-Row Turn

Operating the Zero Turn Rider

STORAGE

Temporary Storage (30 Days Or Less)

Remember, the fuel tank will still contain some gasoline, so never store the unit indoors or in any other area where fuel vapor could travel to any ignition source. Fuel vapor is also toxic if inhaled, so never store the unit in any structure used for human or animal habitation.

Here is a checklist of things to do when storing your unit temporarily or in between uses:

- Keep the unit in an area away from where children may come into contact with it. If there's any chance of unauthorized use, remove the spark plug (s) and put in a safe place. Be sure the spark plug opening is protected from foreign objects with a suitable cover.
- If the unit can't be stored on a reasonable level surface, chock the wheels.
- Clean all grass and dirt from the mower.

Long Term Storage (Longer Than 30 Days)

Before you store your unit for the off-season, read the Maintenance and Storage instructions in the Safety Rules section, then perform the following steps:

1. Drain crankcase oil while engine is hot and refill with a grade of oil that will be required when unit is used again.
2. Prepare the mower deck for storage as follows:
 - a. Remove mower deck from the unit.
 - b. Clean underside of mower deck.
 - c. Coat all bare metal surfaces with paint or light coat of oil to prevent rusting.
3. Clean external surfaces and engine.
4. Prepare engine for storage. See engine owner's manual.
5. Clean any dirt or grass from cylinder head cooling fins, engine housing and air cleaner element.
6. Cover air cleaner and exhaust outlet tightly with plastic or other waterproof material to keep out moisture, dirt and insects.
7. Completely grease and oil unit as outlined in the Normal Care section.
8. Clean up unit and apply paint or rust preventative to any areas where paint is chipped or damaged.
9. Be sure the battery is filled to the proper level with water and is fully charged. Battery life will be increased if it is removed, put in a cool, dry place and fully charged about once a month. If battery is left in unit, disconnect the negative cable.

WARNING

Never store the unit, with gasoline in engine or fuel tank, in a heated shelter or in enclosed, poorly ventilated enclosures. Gasoline fumes may reach an open flame, spark or pilot light (such as a furnace, water heater, clothes dryer, etc.) and cause an explosion.

Handle gasoline carefully. It is highly flammable and careless use could result in serious fire damage to your person or property.

Drain fuel into an approved container outdoors away from open flame or sparks.

10. Drain fuel system completely or add a gasoline stabilizer to the fuel system. If you have chosen to use a fuel stabilizer and have not drained the fuel system, follow all safety instructions and storage precautions in this manual to prevent the possibility of fire from the ignition of gasoline fumes. Remember, gasoline fumes can travel to distant sources of ignition and ignite, causing risk of explosion and fire.

NOTE: Gasoline, if permitted to stand unused for extended periods (30 days or more), may develop gummy deposits which can adversely affect the engine carburetor and cause engine malfunction. To avoid this condition, add a gasoline stabilizer to the fuel tank and run the engine a few minutes, or drain all fuel from the unit before placing it in storage.

STARTING AFTER LONG TERM STORAGE

Before starting the unit after it has been stored for a long period of time, perform the following steps.

1. Remove any blocks from under the unit.
2. Install the battery if it was removed.
3. Unplug the exhaust outlet and air cleaner.
4. Fill the fuel tank with fresh gasoline. See engine manual for recommendations.
5. See engine owner's manual and follow all instructions for preparing engine after storage.
6. Check crankcase oil level and add proper oil if necessary. If any condensation has developed during storage, drain crankcase oil and refill.
7. Inflate tires to proper pressure. Check fluid levels.
8. Start the engine and let it run slowly. DO NOT run at high speed immediately after starting. Be sure to run engine only outdoors or in well ventilated area.

Regular Maintenance



MAINTENANCE SCHEDULE & PROCEDURES

The following schedule should be followed for normal care of your rider and mower. You will need to keep a record of your operating time. Determining operating time is easily accomplished by observing the elapsed time recorded by the hour meter.

SAFETY ITEMS	See Page	Before First Use	Before Each Use	Every 5 Hours	Every 25 Hours	Every 100 Hours	Spring & Fall
Check Safety Interlock System	7	X					X
Check Rider Brakes	22	X					X
Check Mower Blade Stopping Time	23	X				X	
NORMAL CARE ITEMS	See Page	Before First Use	Before Each Use	Every 5 Hours	Every 25 Hours	Every 100 Hours	Spring & Fall
Check Rider/Mower for loose hardware	—		X	X			
Check Engine Oil Level	15*	X	X	X			X
Check Engine Air Filter	15*		X			***X	
Change Engine Oil & Filter **	15*				***X Every 50 Hours		***X
Lubricate Rider & Mower	16					***X	
Check Tire Pressure	14	X				***X	
Check Hydraulic Fluid	15	X				***X	
Check Fuel Filter	15					X	
Clean Battery & Cables	17					X	
Clean & Sharpen Mower Blades	18					X	
Inspect Spark Plug	15*					X	

* See the engine manufacturer's owner's manual.

** Change original engine oil after first 5 hours of operation.

*** More often in hot (over 85° F: 30° C) weather or dusty operating conditions.

CHECK TIRE PRESSURES

Tire Pressure should be checked periodically, and maintained at the levels shown in the chart. Note that these pressures may differ slightly from the "Max Inflation" stamped on the side-wall of the tires. The pressures shown provide proper traction, improve cut quality, and extend tire life.

Tire	Pressure
Front	20 psi (138 kPa)
Rear	15 psi (103 kPa)

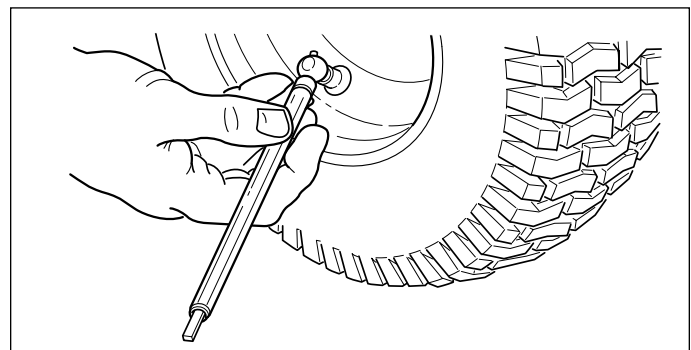

Figure 10. Checking Tire Pressure

CHECKING / ADDING FUEL

To add fuel:

1. Remove the fuel cap (see A, Figure 2).
2. Fill the tank.
Do not overfill. Leave approximately 1" of room in the tank for fuel expansion. Refer to your engine manual for specific fuel recommendations.
3. Install and hand tighten the fuel cap.
4. Repeat same process for opposite tank.

FUEL FILTER

The fuel filter is located in the fuel line between fuel shut off valve and carburetor, near the fuel pump. If filter is dirty or clogged, replace as follows:

1. Shut off the fuel valve.
2. Disconnect the negative battery cable.
3. Place a container below the filter to catch spilled fuel.
4. Using a pliers, open and slide hose clamps from fuel filter.
5. Remove hoses from filter.
6. Install new filter in proper flow direction in fuel line.
7. Secure with hose clamps.
8. Reconnect the negative battery cable when finished.

OIL & FILTER CHANGE

Refer to engine owners manual.

CHECK / CHANGE AIR FILTER

Refer to engine owners manual.

REPLACE SPARK PLUG

Refer to engine owners manual.

CHECK HYDRAULIC OIL LEVEL

NOTE: Do not open the hydraulic reservoir unless oil is being added.

1. Lift up the seat plate to gain access to the oil reservoir compartment.
2. Look at the hydraulic oil reservoir (A, Figure 11) and observe the oil level. When cold, the oil level should be approximately 1/2" below the MAX. HOT OIL LEVEL line. The oil level should never be above the MAX. HOT OIL LEVEL line.
3. If necessary, remove the reservoir cap (B, Figure 11) and add either Mobil 1, 15W-50 synthetic oil or Castrol Syntec 5W-50 oil. **DO NOT** use conventional oils. Make sure area around the fill neck of the reservoir is free of dust, dirt, or other debris.

⚠ WARNING

Gasoline is highly flammable and must be handled with care. Never fill the tank when the engine is still hot from recent operation. Do not allow open flame, smoking or matches in the area. Avoid over-filling and wipe up any spills. Do not remove fuel filter when engine is hot, as spilled gasoline may ignite. DO NOT spread hose clamps further than necessary. Ensure clamps grip hoses firmly over filter after installation.



Do not use gasoline containing METHANOL, gasohol containing more than 10% ethanol, gasoline additives, premium gasoline, or white gas because engine/fuel system damage could result.

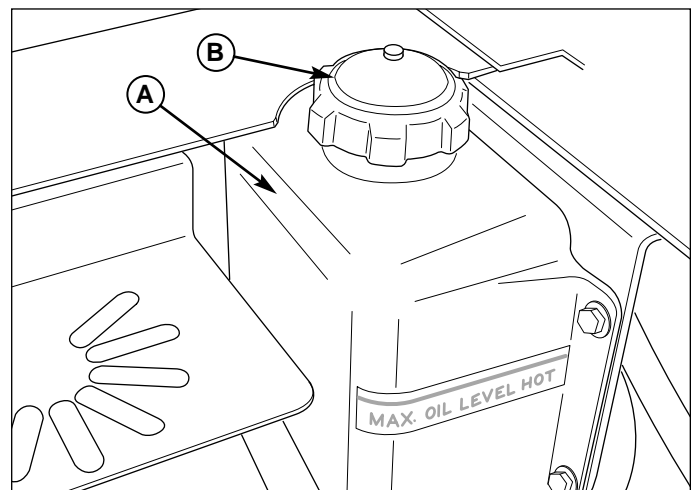

Figure 11. Checking Hydraulic Oil Level

- A. Hydraulic Oil Reservoir
B. Reservoir Cap

Regular Maintenance

LUBRICATION

Lubricate the unit at the following lubrication points.

Grease:



- front caster wheel axles
- motion control pivot bearings
- suspension a-arms
- mower deck pusher bars
- deck lift pivots
- deck lift foot pedal
- front pivot frame
- mower deck idler arm
- mower deck caster pivots

Use grease fittings when present. Disassemble parts to apply grease to moving parts when grease fittings are not installed.

Not all greases are compatible. Ferris Red Grease (part #22285) is recommended, automotive-type high-temperature, lithium grease may be used when this is not available.

Oil:



- control handle pivots
- floor plate hinge
- discharge chute hinge

Generally, all moving metal parts should be oiled where contact is made with other parts. Keep oil and grease off belts and pulleys. Remember to wipe fittings and surfaces clean both before and after lubrication.

BATTERY MAINTENANCE

Checking the Battery Fluid

1. Raise the seat plate to access battery.
2. Remove the battery filler cap (A, Figure 15). Fluid must be even with the split ring full mark. If not, add distilled water.
3. Reinstall the filler cap.

Cleaning the Battery and Cables

1. Disconnect the cables from the battery, negative cable first (C, Figure 15).
2. Clean the battery terminals and cable ends with a wire brush until shiny.
3. Reinstall the battery and reattach the battery cables, positive cable first (see B, Figure 15)
4. Coat the cable ends and battery terminals with petroleum jelly or non-conducting grease.

! WARNING

Be careful when handling the battery. Avoid spilling electrolyte. Keep flames and sparks away from the battery.

When removing or installing battery cables, disconnect the negative cable FIRST and reconnect it LAST. If not done in this order, the positive terminal can be shorted to the frame by a tool.

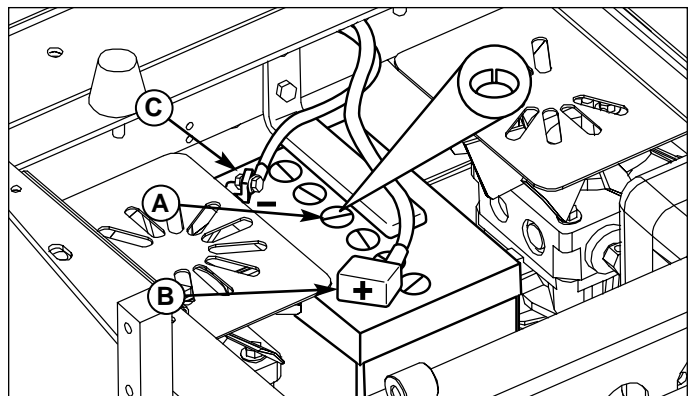

Figure 15. Battery Compartment

- A. Vent Cap(s)
- B. Positive (+) Cable & Terminal
- C. Negative (-) Cable & Terminal

SERVICING THE MOWER BLADES

1. Blades should be sharp and free of nicks and dents. If not, sharpen blades as described in following steps.
2. To remove blade for sharpening, use a 1" wrench on the flats of the spindle shaft while removing the blade mounting bolt with a 15/16" wrench (Figure 16).
3. Use a file to sharpen blade to fine edge. Remove all nicks and dents in blade edge. If blade is severely damaged, it should be replaced.
4. Balance the blade as shown in Figure 17. Center the blade's hole on a nail lubricated with a drop of oil. A balanced blade will remain level.
5. Reinstall each blade with the tabs pointing up toward deck as shown in Figure 18. Secure with a bolt and flat washer and torque bolts to 70-90 ft.lbs. (94-120 N.m.).

⚠ WARNING

For your personal safety, blade mounting bolts must each be installed with a flat washer then securely tightened. Torque blade mounting bolts to 70-90 ft.lbs. (94-120 N.m.)

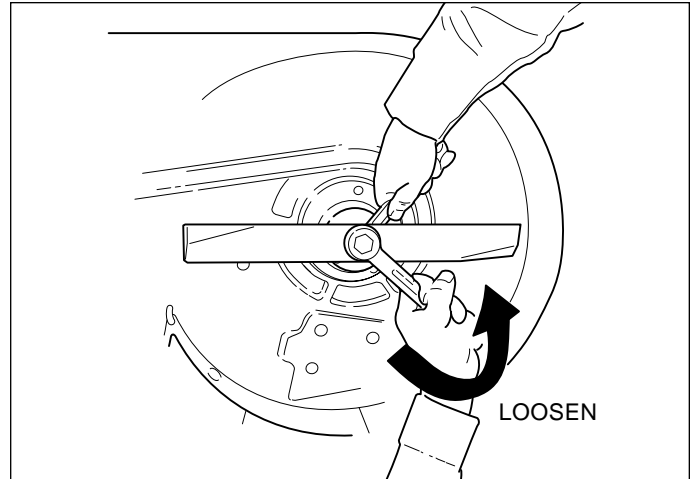

Figure 16. Removing the Blade

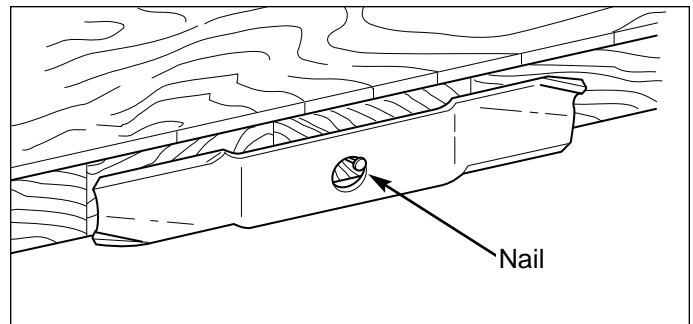

Figure 17. Balancing The Blade

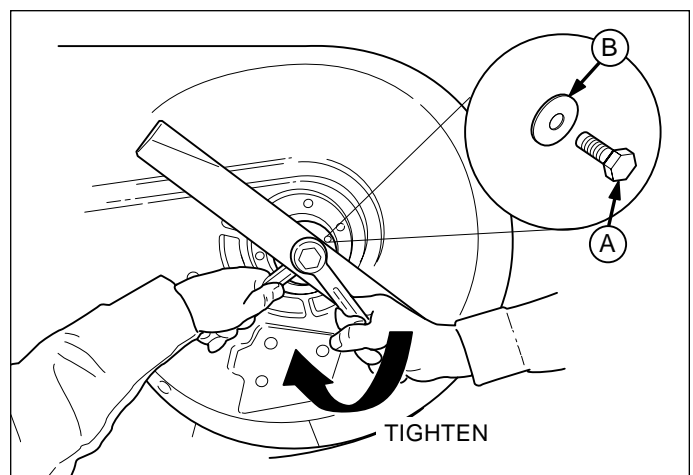

Figure 18. Installing The Blade

- A. Blade Bolt
- B. Flat Washer



Troubleshooting Adjustments & Service

TROUBLESHOOTING

While normal care and regular maintenance will extend the life of your equipment, prolonged or constant use may eventually require that service be performed to allow it to continue operating properly.

The troubleshooting guide below lists the most common problems, their causes and remedies.

See the information on the following pages for instructions on how to perform most of these minor adjustments and service repairs yourself. If you prefer, all of these procedures can be performed for you by your local authorized dealer.

⚠ WARNING

To avoid serious injury, perform maintenance on the tractor or mower only when the engine is stopped and the parking brake engaged.

Always remove the ignition key, disconnect the spark plug wire and fasten it away from the plug before beginning the maintenance, to prevent accidental starting of the engine.

TROUBLESHOOTING THE RIDER

PROBLEM	CAUSE	REMEDY
Engine will not turnover or start.	<ol style="list-style-type: none"> 1. Parking brake not engaged. 2. PTO (electric clutch) switch in ON position. 3. Out of fuel. 4. Engine flooded. 5. Fuse blown. 6. Battery terminals require cleaning. 7. Battery discharged or dead. 8. Wiring loose or broken. 9. Solenoid or starter motor faulty. 10. Safety interlock switch faulty. 11. Spark plug(s) faulty, fouled or incorrectly gapped. 12. Water in fuel. 13. Gas is old or stale. 	<ol style="list-style-type: none"> 1. Engage parking brake. 2. Place in OFF position. 3. If engine is hot, allow it to cool, then refill the fuel tank. 4. Move throttle control out of CHOKE position. 5. Replace fuse. 6. Clean the battery terminals 7. Recharge or replace. 8. Visually check wiring & replace broken or frayed wires. Tighten loose connections. 9. Repair or replace. See authorized service dealer 10. Replace as needed. See authorized service dealer. 11. Clean and gap or replace. See engine manual. 12. Drain fuel & refill with fresh fuel. 13. Drain fuel & replace with fresh fuel.
Engine starts hard or runs poorly.	<ol style="list-style-type: none"> 1. Fuel mixture too rich. 2. Spark plug faulty, fouled, or incorrectly gapped. 	<ol style="list-style-type: none"> 1. Clean air filter. Check choke adjustment (throttle control). 2. Clean and gap or replace. (See engine manual.)
Engine knocks.	<ol style="list-style-type: none"> 1. Low oil level. 2. Using wrong grade oil. 	<ol style="list-style-type: none"> 1. Check/add oil as required. 2. See engine manual.
Excessive oil consumption.	<ol style="list-style-type: none"> 1. Engine running too hot. 2. Using wrong weight oil. 3. Too much oil in crankcase. 	<ol style="list-style-type: none"> 1. Clean engine fins, blower screen and air cleaner. 2. See engine manual. 3. Drain excess oil.
Engine exhaust is black.	<ol style="list-style-type: none"> 1. Dirty air filter. 2. Engine choke control is in closed position. 	<ol style="list-style-type: none"> 1. Replace air filter. See engine manual. 2. Open choke control.

Troubleshooting, Adjustment & Service

Rider Troubleshooting Continued.

PROBLEM	CAUSE	REMEDY
Engine runs, but rider will not drive.	<ol style="list-style-type: none"> 1. Hydraulic release valve(s) in "open" position. 2. Belt is broken. 3. Drive belt slips. 4. Brake is not fully released. 	<ol style="list-style-type: none"> 1. Turn valve(s) clockwise to close. 2. See Drive Belt Replacement. 3. See problem and cause below. 4. See authorized service dealer
Rider drive belt slips.	<ol style="list-style-type: none"> 1. Clutch is out of adjustment. 2. Pulleys or belt greasy or oily. 3. Belt stretched or worn. 	<ol style="list-style-type: none"> 1. See authorized service dealer. 2. Clean as required. 3. Replace belt.
Brake will not hold.	<ol style="list-style-type: none"> 1. Brake is incorrectly adjusted. 2. Brake caliper pads worn. 	<ol style="list-style-type: none"> 1. See Brake Adjustment. 2. Replace with new brake pads.
Rider steers or handles poorly.	<ol style="list-style-type: none"> 1. Steering linkage is loose. 2. Improper tire inflation. 	<ol style="list-style-type: none"> 1. Check and tighten any loose connections. 2. See Regular Maintenance Section.

TROUBLESHOOTING THE MOWER

PROBLEM	CAUSE	REMEDY
Mower will not raise.	<ol style="list-style-type: none"> 1. Lift linkage not properly attached or damaged. 	<ol style="list-style-type: none"> 1. See authorized service dealer for repair.
Mower cut is uneven.	<ol style="list-style-type: none"> 1. Mower not leveled properly. 2. Rider tires not inflated equally or properly. 	<ol style="list-style-type: none"> 1. See Mower Adjustment. 2. See Regular Maintenance Section.
Mower cut is rough looking.	<ol style="list-style-type: none"> 1. Engine speed too slow. 2. Ground speed too fast. 3. Blades are dull. 4. Mower drive belt slipping because it is oily or worn. 5. Blades not properly fastened to arbors. 	<ol style="list-style-type: none"> 1. Set throttle to full. 2. Decrease Ground Speed. 3. Sharpen or replace blades. See Mower Blade Service. 4. Clean or replace belt as necessary. 5. See Servicing the Mower Blades.
Engine stalls easily with mower engaged.	<ol style="list-style-type: none"> 1. Engine speed too slow. 2. Ground speed too fast. 3. Cutting height set too low. 4. Discharge chute jamming with cut grass. 	<ol style="list-style-type: none"> 1. Set to full throttle. 2. Decrease Ground Speed. 3. Cut tall grass at maximum cutting height during first pass. 4. Cut grass with discharge pointing toward previously cut area.
Excessive mower vibration.	<ol style="list-style-type: none"> 1. Blade mounting bolts are loose. 2. Mower blades, arbors, or pulleys are bent. 3. Mower blades are out of balance. 4. Belt installed incorrectly. 	<ol style="list-style-type: none"> 1. Tighten to 70 ft.lbs. (94 N.m.). 2. Check and replace as necessary. 3. Remove, sharpen, and balance blades. See Maintenance Section. 4. Reinstall Correctly.
Excessive belt wear or breakage.	<ol style="list-style-type: none"> 1. Bent or rough pulleys. 2. Using incorrect belt. 	<ol style="list-style-type: none"> 1. Repair or replace. 2. Replace with correct belt.
Mower drive belt slips or fails to drive.	<ol style="list-style-type: none"> 1. Idler pulley spring broken or not properly attached. 2. Mower drive belt broken. 	<ol style="list-style-type: none"> 1. Repair or replace as needed. 2. Replace drive belt.

SEAT ADJUSTMENT

See Figure 19. The seat can be adjusted forward and back. Move the lever forward, position the seat as desired, and release the lever to lock the seat into position.

GROUND SPEED CONTROL LEVER ADJUSTMENT

The control levers can be adjusted in two ways. The alignment of the control levers can be adjusted along with the placement of the levers (how close the ends are to one another) can be adjusted.

To Adjust the Handle Alignment

Loosen the mount bolts (A, Figure 20) and pivot the lever(s) (C, Figure 20) to align with each other.

To Adjust the Handle Placement

Loosen the jam nuts and adjust the placement bolt (B, Figure 20) in or out to properly adjust the lever end spacing.

SPEED BALANCING ADJUSTMENT

If the rider veers to the right or left when the ground speed control levers are in the maximum forward position, the top speed of each of these levers can be balanced by turning the adjustment bolt(s) (A, Figure 21). Only adjust the speed of the wheel that is traveling faster.

To Reduce the Speed of the Faster Wheel

1. Loosen the securing nut.
2. turn the top speed adjustment bolt COUNTER-CLOCKWISE to reduce the speed.
3. Retighten the securing nut when adjustment is complete.

! WARNING

DO NOT adjust the tractor for a faster overall speed forward or reverse than it was designed for.

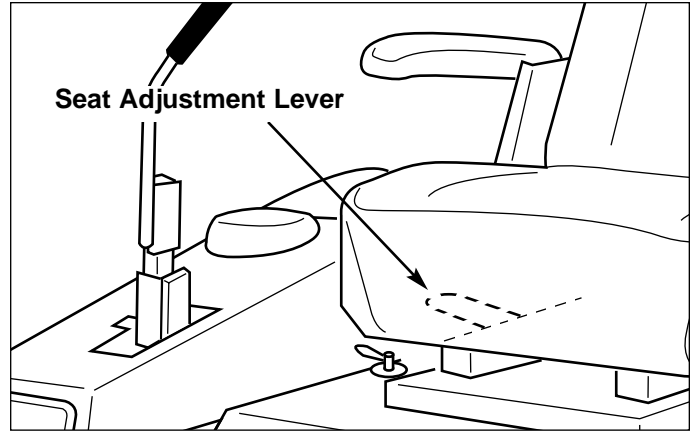

Figure 19. Seat Adjustment

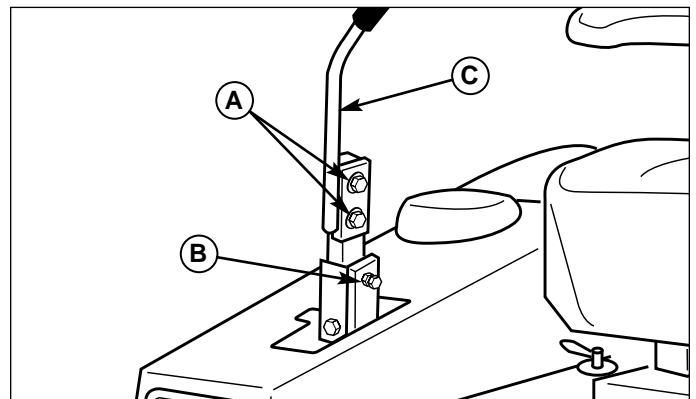

Figure 20. Control Lever Adjustment

- A. Alignment Hardware
- B. Placement Hardware
- C. Ground Speed Control Lever

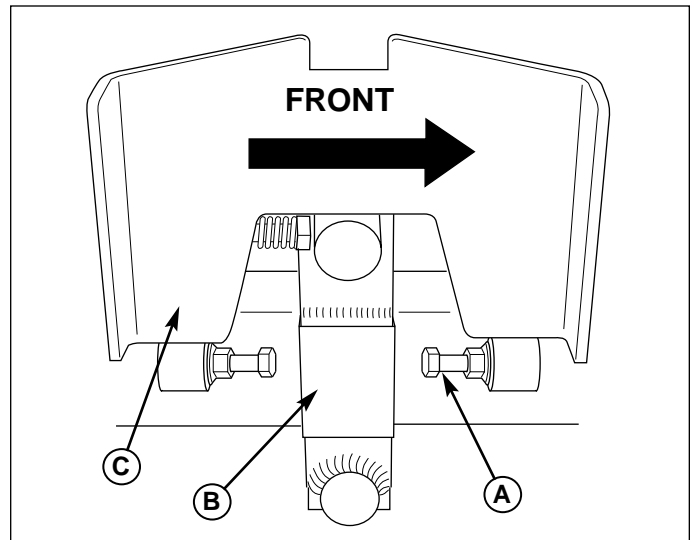

Figure 21. Top Speed Adjustment

(Right side shown with control cover removed.)

- A. Top Speed Adjustment Bolt
- B. Control Lever Base
- C. Neutral Lock Plate

PARKING BRAKE ADJUSTMENT

1. Disengage the PTO, stop the engine, block the front wheels, remove the ignition key, and engage the parking brake.
2. Remove both control covers.
3. Locate the upper brake spring (A, Figure 22).
4. With the parking brake engaged, measure the compressed spring length. The spring should be 2" to 2-1/8" (5.0 - 5.4cm) when compressed.
5. If the spring is not within this range, jack up the rear of the machine and secure with jackstands. Remove both drive tires.
6. Locate the lower brake spring, adjustment nuts and adjustment link (A, B & C, Figure 23).
7. Release the parking brake and turn the adjustment nuts to compress or release the upper spring. Lock the nuts against the adjustment link (C, Figure 23).

CAUTION

Do not adjust the spring to be shorter than 2" when compressed. This may damage the brake caliper.

If this adjustment does not correct a braking problem, see your local Derby dealer.

SUSPENSION HEIGHT ADJUSTMENT

If the rider tilts either side-to-side or front-to-rear, this adjustment will level the frame with the ground.

Although this adjustment may not be necessary, it may be required if additional weight (ie. a grass catcher) is added to the frame or a drive tire is replaced.

To level the frame, loosen the jam nut (B, Figure 24) and turn the height adjustment bolt (A, Figure 24) COUNTER-CLOCKWISE to lower the corresponding side of the frame, and CLOCKWISE to raise the frame.

NOTE: Perform this adjustment on a hard, level surface such as a concrete floor. Making this adjustment will affect the mower cutting height. For fine cutting height adjustment, see your authorized dealer.

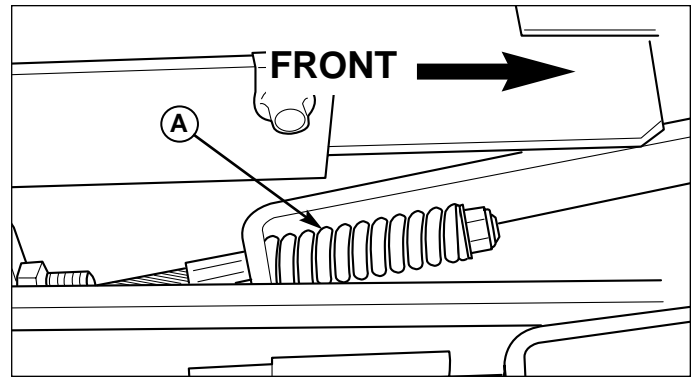

Figure 22. Parking Brake Adjustment

A. Upper Brake Spring

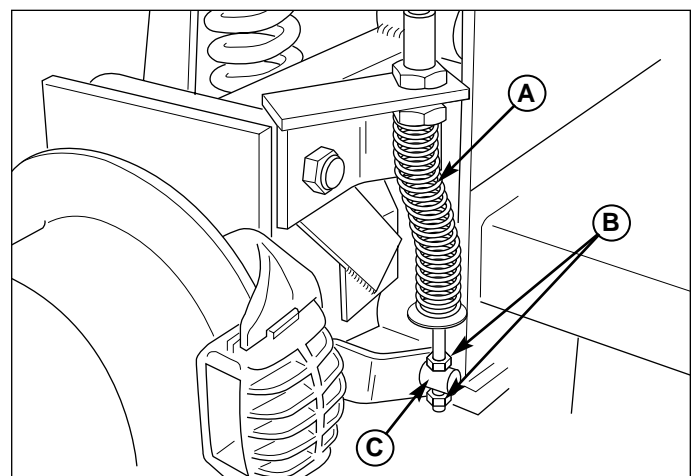

Figure 23. Parking Brake Adjustment

A. Lower Brake Spring

B. Adjustment Nuts

C. Adjustment Link

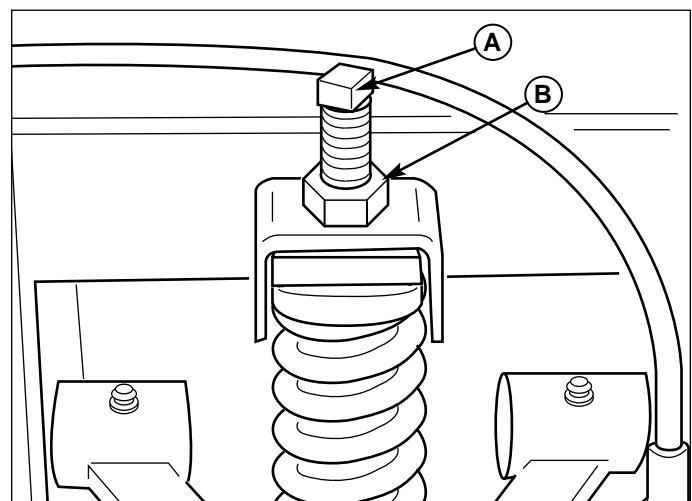

Figure 24. Suspension Height Adjustment

A. Height Adjustment Bolt

B. Jam Nut

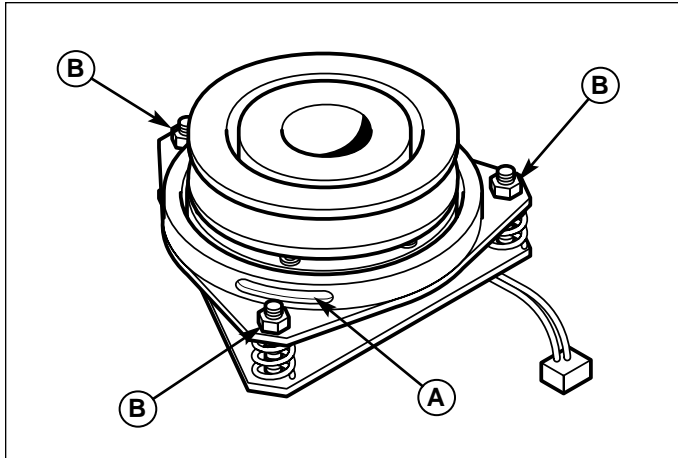

Figure 25. PTO Clutch Adjustment
 A. Adjustment Window (Qty. 3, one shown)
 B. Adjustment Nut

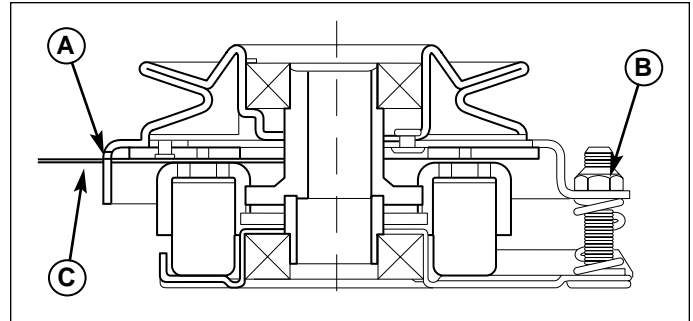

Figure 26. Adjust PTO Clutch
 A. Window
 B. Adjustment Nut
 C. .016"-.018" (0.40-0.45mm) Feeler Gauge

PTO CLUTCH ADJUSTMENT

Check the PTO clutch adjustment after the initial 50 hour break-in period and then after every 250 hours of operation. Also perform the following procedure if the clutch is slipping or will not engage, or if a new clutch has been installed.

1. Remove key from ignition switch and disconnect spark plug wires to prevent the possibility of accidental starting while the PTO is being adjusted.
2. See Figure 25. Note the position of the 3 adjustment windows (A) in the side of the brake plate and the nylock adjustment nuts (B).
3. Insert a .016"-.018" (0.40-0.45mm) feeler gauge (C) through each window, positioning the gauge between the rotor face and the armature face as shown in Figure 26.
4. Alternately tighten the adjustment nuts (B, Figure 25) until the rotor face and armature face just contacts the gauge.
5. Check the windows for an equal amount of tension when the gauge is inserted and removed, and make any necessary adjustments by tightening or loosening the adjustment nuts.

NOTE: The actual air gap between the rotor and armature may vary even after performing the adjustment procedure. This is due to dimensional variations on component parts, and is an acceptable condition.

6. Check the mower blade stopping time. The mower blades and mower drive belt should come to a complete stop within five seconds after the electric PTO switch is turned off.

⚠️ WARNING

To avoid serious injury, perform adjustments only with engine stopped, key removed and tractor on level ground.

Blade Brake Check

Mower blades and mower drive belt should come to a complete stop within five seconds after electric PTO switch is turned off.

1. With parking brake engaged, PTO disengaged and an operator in the seat, start the engine engine.
2. Have an assistant observe the mower drive belt through the open end of the left-hand arbor cover. Engage the PTO and wait several seconds. Disengage the PTO and check the amount of time it takes for the mower drive belt to stop.
3. If the mower drive belt does not stop within five seconds, perform the PTO Clutch Adjustment. If the belt still does not stop within 5 seconds, see your dealer.

Troubleshooting, Adjustment & Service

NEUTRAL ADJUSTMENT

If the tractor “creeps” while the ground speed control levers are locked in NEUTRAL, than it may be necessary to adjust the control linkage.

NOTE: Perform this adjustment on a hard, level surface such as a concrete floor.

1. Disengage the PTO, engage the parking brake and turn off the engine.
2. There are three (3) nuts on the linkage rod. The first two are to be used together to turn the rod and the third (towards the rear of the machine) is used to lock the rod in place. Loosen the third jam nut (B, Figure 27) and turn the adjustment linkage (A, Figure 27) to adjust. If the machine creeps forward, turn the linkage CLOCKWISE (while standing at the rear of the machine, facing forward), if the machine creeps backward, turn the linkage COUNTER-CLOCKWISE.
3. Lock the jam nut (B) when neutral is achieved.

NOTE: This adjustment should not be performed while the machine is running. It may take several attempts to achieved neutral, depending upon how much the machine creeps.

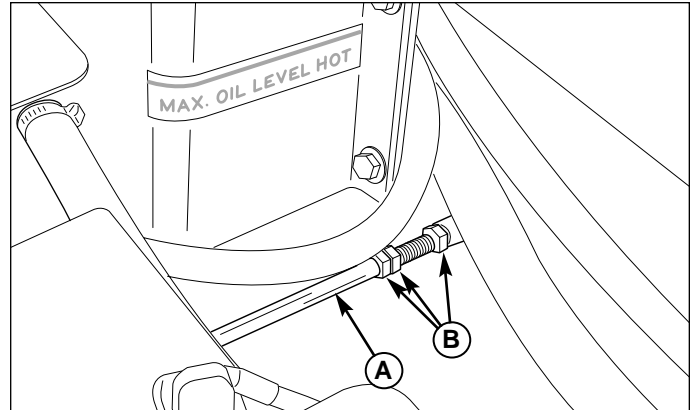

Figure 27. Neutral Adjustment

- A. Adjustment Linkage Rod
- B. Nuts

NEUTRAL SPRING RETURN ADJUSTMENT

This adjustment will tailor the “feel” of the control levers to the operator.

Each of the springs (A, Figure 28) has three adjustment holes (B, Figure 28). The closer the spring is located to the neutral return arm’s pivot (D, Figure 28), the less spring force will be felt by the operator while driving and will return to neutral slower.

The farther the spring is located from the neutral return arm’s pivot (D, Figure 28), the more spring force will be felt by the operator while driving and will return to neutral faster.

NOTE: These adjustments must be made to BOTH sides at the same time, and be placed in the SAME position to one another.

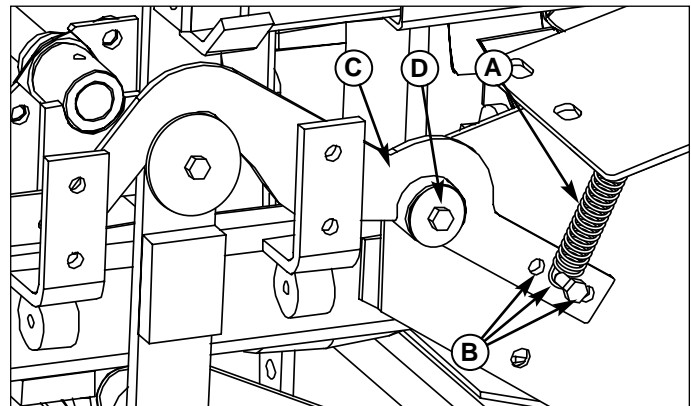

Figure 28. Neutral Spring Return Adjustment

- A. Neutral Return Spring
- B. Adjustment Holes
- C. Neutral Return Arm
- D. Neutral Return Arm Pivot

CUTTING HEIGHT ADJUSTMENT

⚠ WARNING

Before checking mower, shut off PTO and engine. Allow all moving parts to stop. Remove ignition key, then disconnect the spark plug wire and fasten it away from the spark plug.

The cutting height adjustment pin (A, Figure 29) controls the mower cutting height. The cutting height is adjustable between 1-3/4" (4.4cm) and 5" (12.7cm) in 1/4" (.64cm) increments.

Depress the deck lift foot pedal (B, Figure 29), placing the majority of the force on the top edge of the pedal until it locks into the "TRANSPORT" position. Place the cutting height adjustment pin in the desired cutting height. Depress the deck lift foot pedal, placing the majority of the force on the bottom edge of the pedal to release the pedal from the "TRANSPORT" position.

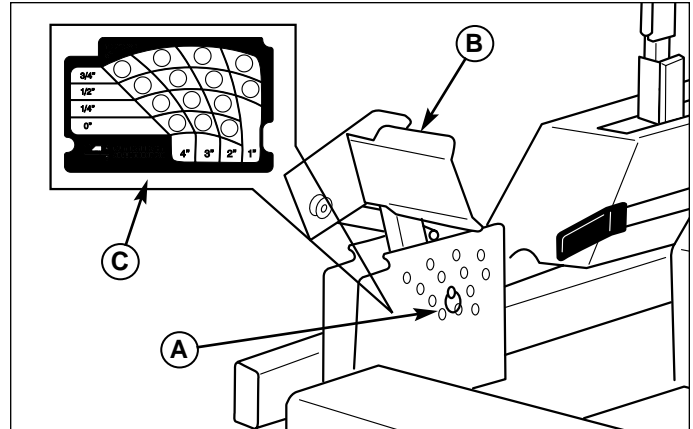

Figure 29. Cutting Height Adjustment

- A. Cutting Height Adjustment Pin
- B. Deck Lift Foot Pedal
- C. Cutting Height Selection Decal

DECK LEVELING ADJUSTMENT

1. Park the machine on a flat, level floor and engage the parking brake. Rear tires must be inflated to 15 psi; front tires to 20 psi.
2. With the deck height adjustment pin in the 4" position, adjust the 5/8" hex nuts on either side of the front spring rod pivot (see Figure 30) until the rear lower edge of the cutter deck directly behind the chain is 3-5/8" from the floor. The front lower edge of the cutter deck directly in front of the eyebolt should be 3-1/2" from the floor (4-1/2" for ACP deck). If not, adjust the front deck hanger eyebolt to correct the cutting height. Perform this step to both rods.
3. With the deck height adjustments complete and cutting height still set at 4", adjust the deck lift spring to a compressed length of 14-1/4" (measure spring only). Adjust the length of the deck lift spring by tightening or loosening the (2) 5/8" hex nuts that are closest to the spacer at the front end of the spring (see Figure 30). After adjustment is made, tighten these two nuts together. Perform this step to both springs.

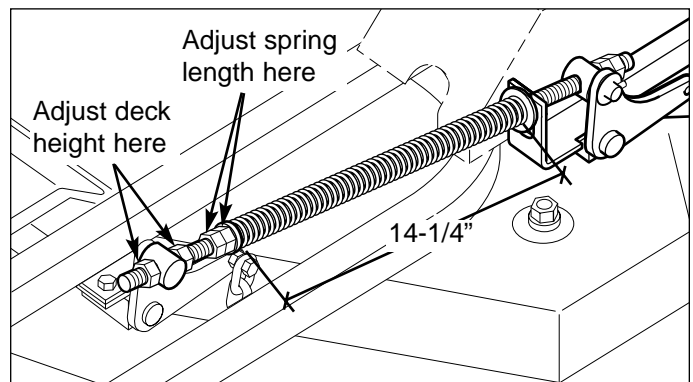

Figure 30. Mower Deck Adjustment

HYDRAULIC PUMP DRIVE BELT REPLACEMENT

1. Park the tractor on a smooth, level surface such as a concrete floor. Disengage the PTO, engage the parking brake, turn off the engine, and remove the ignition key.
2. Remove the PTO drive belt (see MOWER BELT REPLACEMENT for removal instructions).
3. Loosen the nut towards the front of the machine on the spring anchor hook (H, Figure 31) to release the majority of the belt tension. Use caution and remove the nut to completely release the tension.
4. Remove the old belt and replace it with the new one. Make sure the V-side of the belt runs in the grooves of the crankshaft pulley and pump pulleys (B & C, Figure 31).
5. Reinstall the anchor hook (H, Figure 31) into the anchor tab and loosely fasten the nut. Adjust the spring until a measurement of 7-3/4" is achieved from the outside if the spring hooks. Tighten nut.
6. Reinstall the PTO drive belt.

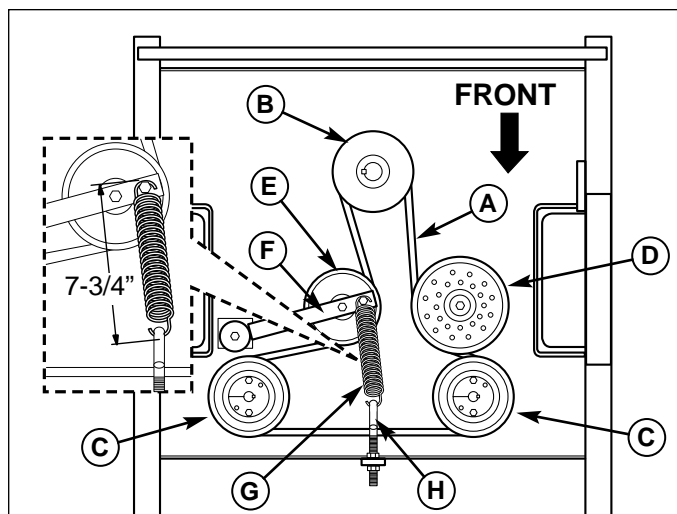

Figure 31. Hydraulic Pump Drive Belt Replacement

- | | |
|------------------------------|-----------------------|
| A. Pump Drive Belt | E. Idler Pulley |
| B. Crankshaft Pulley | F. Idler Arm |
| C. Pump Pulley | G. Spring |
| D. Idler Pulley (stationary) | H. Spring Anchor Hook |

MOWER BELT REPLACEMENT



To avoid damaging belts, DO NOT PRY BELTS OVER PULLEYS.

1. Park the tractor on a smooth, level surface such as a concrete floor. Disengage the PTO, engage the parking brake, turn off the engine, and remove the ignition key.
2. Remove the hardware fastening the PTO clutch to the rubber anchor pad.
3. Remove the hairpin clip and clevis pin and remove the deck lift foot pedal. Lift the floor plate to gain access to the PTO drive belt.
4. Loosen the spring compression nut (B, Figure 32) to release the belt tension.
5. Slide the drive belt over the edge of the idler pulley. Drop the belt from the PTO clutch pulley groove.
6. Remove the old belt and replace with a new one. Make sure the V-side of the belt runs in the pulley grooves (Figure 33).
7. Install the drive belt on the PTO pulley, the spindle pulleys and idler pulleys. Tighten the spring compression nut (B, Figure 32) until the belt tension spring (A, Figure 32) is 1-1/2" long.
8. Reinstall the hardware fastening the clutch to the rubber anchor pad.
9. Run the mower under no-load condition for about 5 minutes.

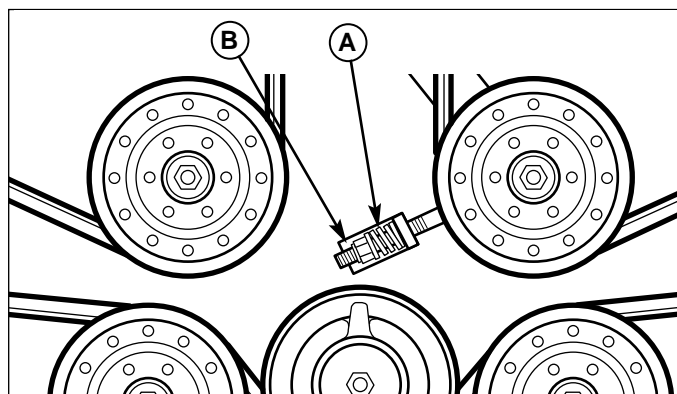

Figure 32. Mower PTO Belt

- | |
|---------------------------|
| A. Belt Tension Spring |
| B. Spring Compression Nut |

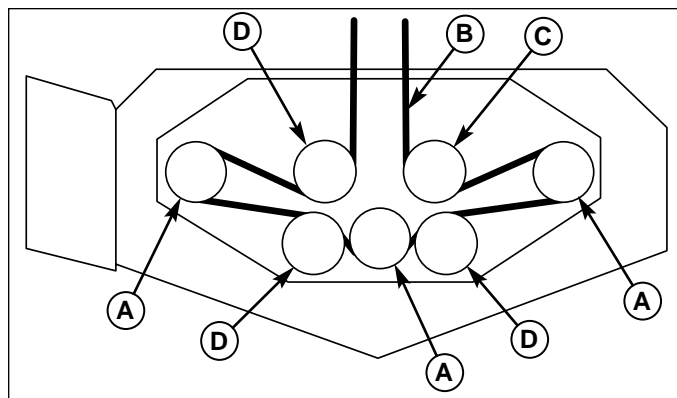

Figure 33. Mower PTO Belt Routing

- | | |
|-------------------|-------------------------------|
| A. Spindle Pulley | C. Spring-loaded Idler Pulley |
| B. PTO Drive Belt | D. Stationary Idler Pulley |

BATTERY SERVICE

WARNING

Keep open flames and sparks away from the battery; the gasses coming from it are highly explosive. Ventilate the battery well during charging.

Checking Battery Voltage

A voltmeter can be used to determine condition of battery. When engine is off, the voltmeter shows battery voltage, which should be 12 volts. When engine is running, the voltmeter shows voltage of charging circuit which normally is 13 to 14 volts.

A dead battery or one too weak to start the engine may not mean the battery needs to be replaced. For example, it may mean that the alternator is not charging the battery properly. If there is any doubt about the cause of the problem, see your dealer. If you need to replace the battery, follow the steps under Cleaning the Battery & Cables in the Regular Maintenance Section.

Charging a Completely Discharged Battery

1. Be aware of all the safety precautions you should observe during the charging operation. If you are unfamiliar with the use of a battery charger and hydrometer, have the battery serviced by your dealer.
2. Add distilled water sufficient to cover the plate (fill to the proper level near the end of the charge). If the battery is extremely cold, allow it to warm before adding water because the water level will rise as it warms. Also, an extremely cold battery will not accept a normal charge until it becomes warm.
3. Always unplug or turn the charger off before attaching or removing the clamp connections.
4. Carefully attach the clamps to the battery in proper polarity (usually red to [+] positive and black to [-] negative).
5. While charging, periodically measure the temperature of the electrolyte. If the temperature exceeds 125° F (51.6° C), or if violent gassing or spewing of electrolyte occurs, the charging rate must be reduced or temporarily halted to prevent battery damage.
6. Charge the battery until fully charged (until the specific gravity of the electrolyte is 1.250 or higher and the electrolyte temperature is at least 60° F). The best method of making certain a battery is fully charged, but not over charged, is to measure the specific gravity of a cell once per hour. The battery is fully charged when the cells are gassing freely at low charging rate and less than 0.003 change in specific gravity occurs over a three hour period.

Jump Starting With Auxiliary (Booster) Battery

Jump starting is not recommended. However, if it must be done, follow these directions. Both booster and discharged batteries should be treated carefully when using jumper cables. Follow the steps below EXACTLY, being careful not to cause sparks. Refer to Figure 34 .

1. Both batteries must be of the same voltage.
2. Position the vehicle with the booster battery adjacent to the vehicle with the discharged battery so that booster cables can be connected easily to the batteries in both vehicles. Make certain vehicles do not touch each other.
3. Wear safety glasses and shield eyes and face from batteries at all times. Be sure vent caps are tight. Place damp cloth over vent caps on both batteries.
4. Connect positive (+) cable to positive post of discharged battery (wired to starter or solenoid).
5. Connect the other end of same cable to same post marked positive (+) on booster battery.
6. Connect the second cable negative (-) to other post of booster battery.
7. Make final connection on engine block of stalled vehicle away from battery. Do not lean over batteries.
8. Start the engine of the vehicle with the booster battery. Wait a few minutes, then attempt to start the engine of the vehicle with the discharged battery.
9. If the vehicle does not start after cranking for thirty seconds, STOP PROCEDURE. More than thirty seconds seldom starts the engine unless some mechanical adjustment is made.
10. After starting, allow the engine to return to idle speed. Remove the cable connection at the engine or frame. Then remove the other end of the same cable from the booster battery.
11. Remove the other cable by disconnecting at the discharged battery first and then disconnect the opposite end from the booster battery.
12. Discard the damp cloths that were placed over the battery vent caps.

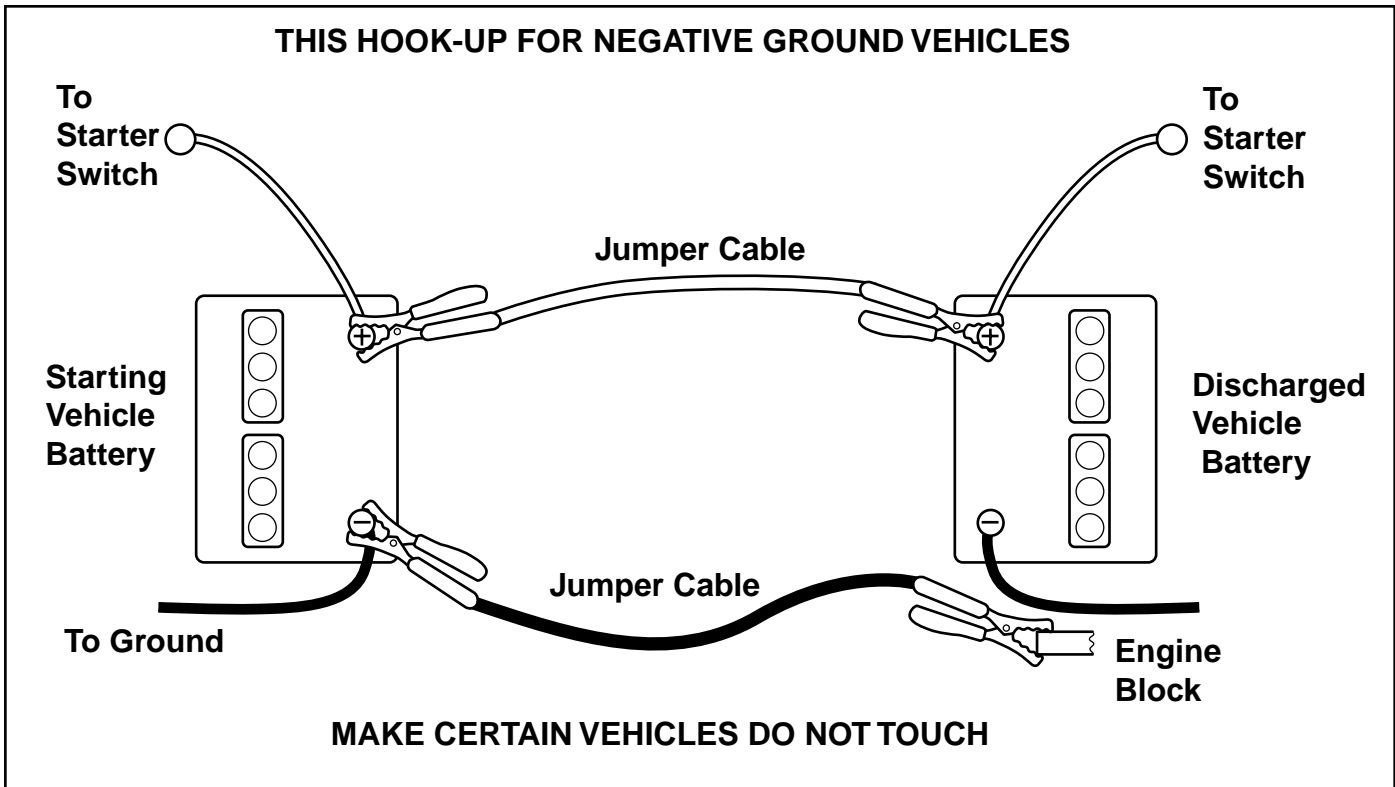

Figure 34. Jump Starting

⚠ WARNING

Any procedure other than the preceding could result in:

- (1) personal injury caused by electrolyte squirting out the battery vents,
- (2) personal injury or property damage due to battery explosion,
- (3) damage to the charging system of the booster vehicle or of the immobilized vehicle.

Do not attempt to jump start a vehicle having a frozen battery because the battery may rupture or explode. If a frozen battery is suspected, examine all fill vents on the battery. If ice can be seen or if the electrolyte fluid cannot be seen, do not attempt to start with jumper cables as long as the battery remains frozen.

⚠ WARNING

For your personal safety, use extreme care when jump starting. Never expose battery to open flame or electric spark – battery action generates hydrogen gas which is flammable and explosive. Do not allow battery acid to contact skin, eyes, fabrics, or painted surfaces. Batteries contain a sulfuric acid solution which can cause serious personal injury or property damage.

When removing or installing battery cables, disconnect the negative cable **FIRST** and reconnect it **LAST**. If not done in this order, the positive terminal can be shorted to the frame by a tool.

To avoid engine damage, do not disconnect battery while engine is running. Be sure terminal connections are tight before starting.



Lawn Care & Mowing Information

GENERAL INFORMATION

Proper mowing is an important part of maintaining your lawn in the best possible condition. A healthy and well maintained lawn is better able to resist drought, weeds, and other stresses. But too much maintenance is as detrimental to your lawn as neglect. Proper care for your lawn involves more than just “cutting the grass.” To have a healthy lawn, you need to know:

- Types of Grass, Climate and Conditions
- How and When to Water, Fertilize & Aerate
- How High to Mow the Grass
- When and How Often to Mow
- What Mowing Patterns to Use
- Proper Mowing Methods
- How to Solve Common Mowing Problems

TYPES OF GRASS, CLIMATE AND CONDITIONS

A variety of grasses are commonly grown in household lawns, but two main groups known as cool-season grasses (varieties of bluegrass, ryegrass, and fescue), and warm-season grasses (typically bermuda, buffalo grass, and zoysia varieties) are the most common.

The cool-season grasses are better suited to cooler climates, and do not endure hot and dry weather as well as warm-season grasses, but conversely, the warm-season grasses do not grow as well in cooler climates. Most residential lawns are typically seeded with a mixture of these grasses. (A local nursery or lawn center may help you to identify what kind of grass your lawn contains from a sample.)

Knowing your climate and conditions is also important to proper lawn care. Drier climates or conditions will require additional watering, while wetter climates may require more frequent mowing.

HOW AND WHEN TO WATER, FERTILIZE & AERATE

Every lawn’s watering needs are unique and are dependent upon the type of grass and soil, the amount of local rainfall, and other conditions. **Most lawns are watered too often, but with too little water.** However too much water can allow development of diseases with your lawn. **It is best to water the lawn only when necessary, and then to water it slowly, evenly, and deeply—imitating a slow, soaking rain.**

WHEN TO WATER YOUR LAWN

When the lawn begins to wilt, the grass’s color dulls, or footprints stay compressed for more than a few seconds, the lawn is beginning to dry out, and needs additional moisture. The best time to water is early morning to allow the water to soak deeply into the lawn and reduce the amount that evaporates in the hot afternoon sun.



HOW TO WATER YOUR LAWN

The best method of watering a lawn is to imitate a slow, soaking rain, applying about 1 inch of water. A method of verifying the amount that you have watered, is to place several empty tin cans (low shallow cans work best) in various spots around the lawn, and check the depth of water in the can during the watering process.

HOW TO FERTILIZE YOUR LAWN

Fertilizing with a slow-release fertilizer provides missing nutrients which help create slow, even growth. While opinions vary on the need for fertilizing, when and how much to fertilize will be more a factor of the condition of the lawn and soil than any routine. Remember that over-fertilizing can cause harm, and that most fertilizing should be applied in the spring so that it will release into the lawn through the summer. For more information, check with a local nursery or lawn care specialist, and read and follow the fertilizer manufacturer’s instructions.

AERATING YOUR LAWN

Consider aerating your lawn in spring. Using an aerator to remove cores of soil from the lawn increases the speed of clipping decomposition and encourages deeper root growth by opening up the soil and permitting greater movement of water, fertilizer and air.

Lawn Care & Mowing Information

HOW HIGH TO MOW THE GRASS

Often cutting height is a matter of personal preference. Typically, you should mow the grass when it is between three and five inches high. The proper cutting height range for a specific lawn will depend upon several factors, including the type of grass, the amount of rainfall, the prevailing temperature, and the lawn's overall condition.

Cutting the grass too short causes weak, thin grass plants, which are easily damaged by dry periods and pests. Cutting too short is often more damaging than allowing the grass to be slightly higher.

Letting grass grow a bit longer—especially when it is hot and dry—reduces heat build-up, preserves needed moisture and protects the grass from heat damage and other problems. However, allowing grass to grow too high can cause thin turf and additional problems.

Cutting off too much at one time shocks the plant's growth system and weakens the grass plants. **A good rule of thumb is the 1/3 rule: to cut no more than one third of the grass height, and never more than 1 inch at a time.**

The amount of grass you are able to cut in one pass is also effected by the type of mowing system you are using (for example, broadcasting with side discharge decks can process a much larger volume of grass than mulching does).

NOTE: We cover some specific mowing instructions for mulching and broadcasting later in this Lawn Care section.

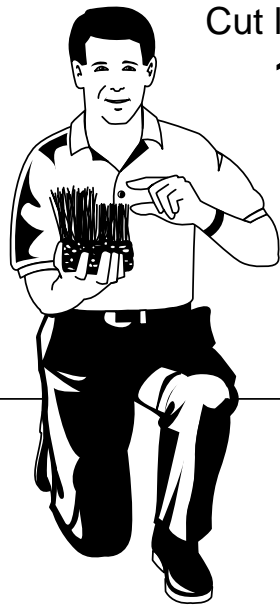

Cut less than
1/3

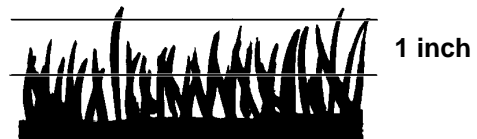
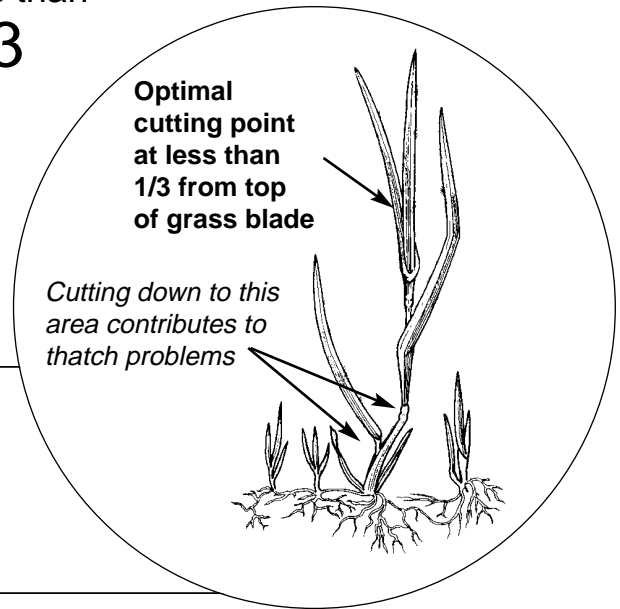

Proper Cutting Height

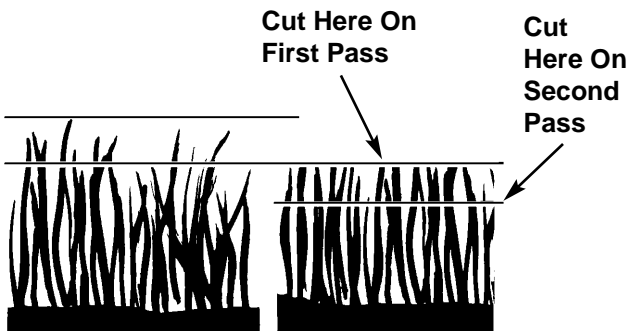

Tall Grass Requires Incremental Cutting

For extremely tall grass, set the cutting height at maximum for the first pass, and then reset it to the desired height and mow a second or third time.

Don't cover the grass surface with a heavy layer of clippings. Consider using a grass collection system and starting a compost pile.

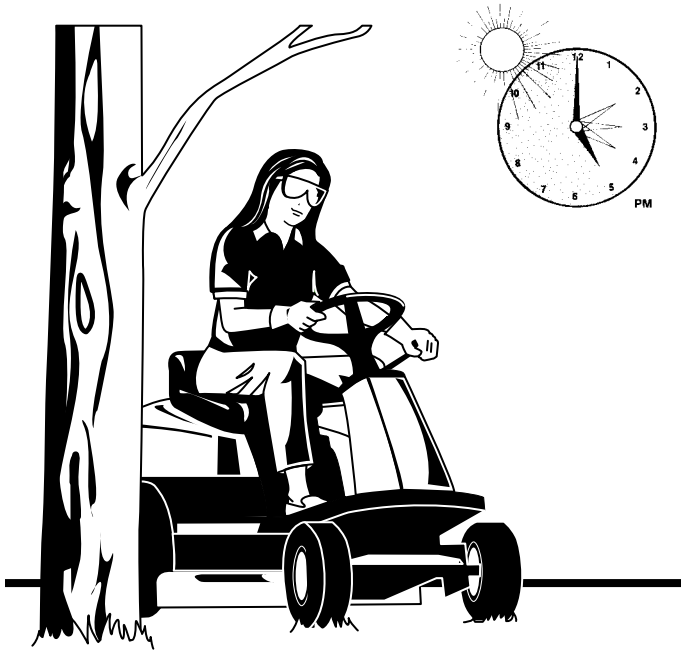

WHEN AND HOW OFTEN TO MOW

The time of day and condition of the grass greatly affect the results you'll get when mowing. For the best results, follow these guidelines:

- I Mow when the grass is between three and five inches high.
- I Mow with sharp blades. Short clippings of grass one inch or shorter decompose more quickly than longer blades. Sharp mower blades cut grass cleanly and efficiently, preventing frayed edges which harm the grass.
- I Mow at time of day when the grass is cool and dry. Late afternoon or early evening often provide these ideal mowing conditions.
- I Avoid mowing after rain or even heavy dew, and never mulch when the grass is wet (moist grass does not mulch well, and clumps beneath the mower deck).

WHAT MOWING PATTERNS TO USE

Always start mowing on a smooth, level area.

The size and type of area to be mowed will determine the best mowing pattern to use. Obstructions such as trees, fences and buildings, and conditions such as slopes and grades must also be considered.

- I Cut long straight strips overlapping slightly.
- I Where possible, change patterns occasionally to eliminate matting, graining or a corrugated appearance.
- I For a truly professional cut, mow across the lawn in one direction, then recut the lawn by mowing perpendicular to the previous cut.

Where possible, make one or two passes around the outside of the area discharging the grass INTO the lawn to keep the cut grass off fences and walks.

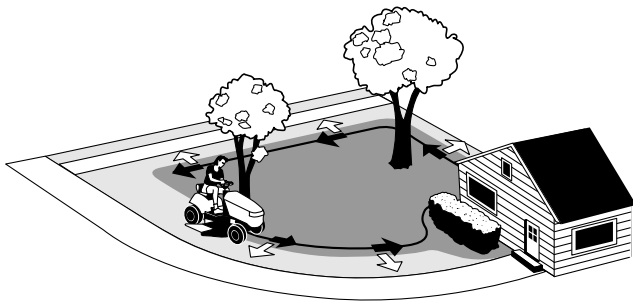
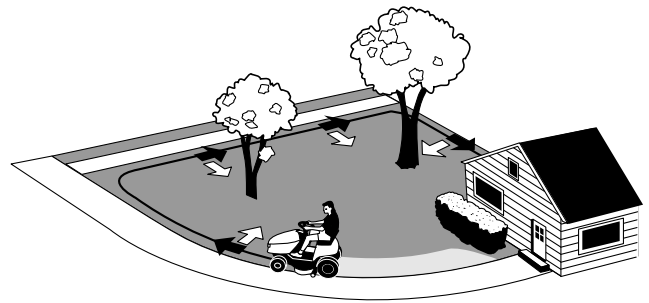

The remainder of the mowing should be done in the opposite direction so that the clippings are dispersed OUT onto the area of lawn previously cut.

Note: Always operate the engine at full throttle when mowing.

If you hear the engine slowing down, you are mowing too fast—using a slower ground speed will improve the cutting efficiency of the blades and prevents many common cutting problems. Use an appropriate ground speed for the thickness and height of the grass you are cutting (3rd gear or slower for manual gear models). If you hear the engine slowing down you are mowing too fast, use a slower ground speed.

Lawn Care & Mowing Information

MOWING METHODS

Proper Broadcast Mowing

Broadcasting, or side-discharging, disperses fine clippings evenly over the entire lawn. Many golf courses use this method. Your mower has a deep dish deck to allow freer circulation of clippings so they are broadcast evenly over the lawn.

ENGINE SPEED & GROUND SPEED FOR BROADCASTING

Always operate the engine at full throttle when mowing. If you hear the engine slowing down, you are mowing too fast—using a slower ground speed will improve the cutting efficiency of the blades and prevents many common cutting problems.

ALWAYS use an appropriate ground speed for the thickness and height of the grass you are cutting (3rd gear or slower for manual gear models). If you hear the engine



slowing down you are mowing too fast, use a slower ground speed.

HOW MUCH GRASS TO CUT OFF WHEN BROADCASTING

Mow when the grass is 3-5 inches long. Do not cut the grass shorter than 2 to 2-1/2 inches. Do not cut off more than 1 inch of grass in a single pass.

Proper Mulching

Mulching consists of a mower deck which cuts and recuts clippings into tiny particles and which then blows them down INTO the lawn. These tiny particles decompose rapidly into by-products your lawn can use.

UNDER PROPER CONDITIONS, your mulching mower will virtually eliminate noticeable clippings on the lawn surface.

NOTE: When mulching under heavy cutting conditions, a rumbling sound may be present and is normal.

MULCHING REQUIRES EXCELLENT MOWING CONDITIONS

Mulching mowers cannot function properly if the grass is wet, or if the grass is simply high to cut. Even more than normal mowing, mulching requires that the grass be dry and the appropriate amount is cut.

Do not use the mower as a mulching mower during the first two or three mowings in the spring. The long grass blades, quick growth, and often wetter conditions are more suitable for broadcasting (side-discharging) or grass bagging operation.

ENGINE SPEED & GROUND SPEED FOR BROADCASTING

Use full engine throttle matched with a slow ground speed so that clippings will be finely cut. Ground speed while mulching should be HALF of the speed that would be used when broadcasting (side discharging) under similar conditions. Since mulching requires more horsepower than broadcasting, using a slower ground speed is vitally important for proper mulching operation.

Mulching Action

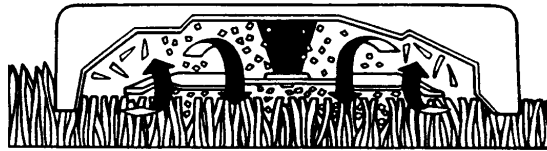

HOW MUCH GRASS TO MULCH

The best mulching action typically results from cutting only the top 1/2 inch to 3/4 inch of grass blade. This provides short clippings which decompose properly (much more quickly than longer clippings). The ideal cutting

height will vary with climate, time of year, and quality of your lawn. We recommend that you experiment with both the cutting height and ground speed until you achieve the best cut. Start with a high cutting height and using progressively lower settings until you find a cutting height that is matched to your mowing conditions and preferences.

TIPS On Dealing With Clippings

Clippings are **beneficial** to your lawn. A common misconception about clippings is that they automatically lead to thatch—this is untrue. Short clippings produced by broadcasting and clippings produced by mulching methods actually **contribute to a healthy lawn** because they:

- Reduce the evaporation of water from your lawn.
- Provide a cushioning layer to reduce lawn wear.
- Moderate soil temperature.
- Clippings act as a safe, non-polluting and inexpensive fertilizer that nourishes your lawn. Fresh cut grass blades are 85% water, and are a rich source of nitrogen which is essential to lush growth. And one garbage bag of clippings contains about 1/4 lb. of usable organic nitrogen.

COMPOSTING

The best way to recycle excess clippings and leave your lawn looking immaculate is to collect them with an efficient collection system and deposit them in a compost pile. A compost pile is a collection of grass, leaves, and other organic wastes which—when properly tended—decompose into an odorless, topsoil material. This material, in turn, acts as an inexpensive fertilizer for your lawn and garden.

How to start a healthy compost pile:

- 1 Build a bin using bricks, fencing, cement blocks, etc. or purchase a prefabricated bin from a garden store. The bin should also have venting on each side and from the bottom to the top.

- 2 Fill the bin with alternating layers of yard waste. Follow this recipe:

First layer: 3-4 inches of chopped brush or other coarse material.

Second layer: 6-8 inches of mixed leaves, grass clippings, sawdust, etc. Materials should be "sponge damp."

Third layer: 1 inch of soil to add micro-organisms that help break down organic matter.

Fourth layer: 1-2 inches of manure to provide the nitrogen needed by micro-organisms.

Keep adding layers until the bin is almost full. Top off with a 4-6 inch layer of straw and scoop out a "basin" to catch rain water.

- 3 Four or five days later the pile will reach temperatures of 140-160 degrees. At this time you'll notice it settling, a good sign your compost is working properly.
- 4 After 5-6 weeks, fork materials into a new pile, turning the outside of the old heap into the center of the new one. Add water if necessary. The compost should be ready to use within three to four months when dark brown, crumbly, and earthy-smelling.



Lawn Care & Mowing Information

SOLUTIONS FOR COMMON MOWING PROBLEMS

Streaking

Streaking is when thin strips of uncut grass are left behind the mower. Streaking is usually caused by operator error or poor blade maintenance.

Streaking

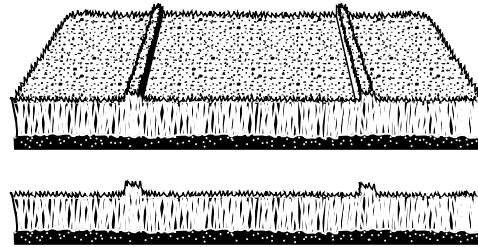

CAUSE

- Blades are not sharp
- Blades are worn down too far
- Engine speed is too slow
- Ground speed is too fast
- Deck is plugged with grass
- Not overlapping cutting rows enough
- Not overlapping enough when turning

SOLUTION

- Sharpen your blades
- Replace your blades
- Always mow at full throttle
- Slow down
- Clean out the mower
- Overlap your cutting rows
- When turning your effective cutting width decreases—overlap more when turning

Stepped Cutting

Stepped cutting is sharp ridges or uneven levels left in the lawn surface. Stepped cutting is usually caused by mower deck damage or misadjustment, or damage to mower blades.

Stepped Cutting

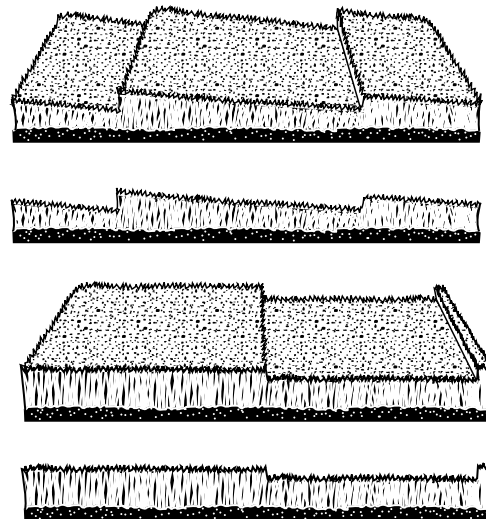

CAUSE

- Deck is not leveled correctly
- Tires are not properly inflated
- Blades are damaged
- Deck shell is damaged
- Mower spindle is bent or loose
- Blades are installed incorrectly

SOLUTION

- Level the deck correctly
- Check and inflate the tires
- Replace the blades
- Repair or replace the deck
- Repair or replace the spindle
- Reinstall the blades correctly

Lawn Care & Mowing Information

Uneven Cutting

Uneven cutting is waviness or smooth troughs in the lawn surface. Uneven cutting is usually caused by mower deck damage or misadjustment.

Uneven Cutting

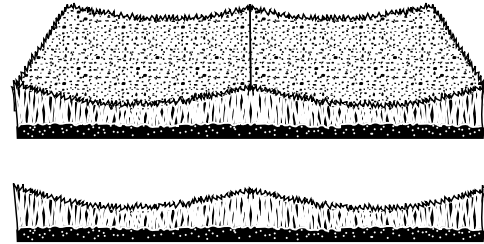

CAUSE

- Deck is not leveled correctly
- Blades are dull or worn
- Blades are damaged
- Deck is clogged with grass clippings
- Deck shell is damaged
- Mower spindle is bent or loose
- Blades are installed incorrectly

SOLUTION

- Level the deck correctly
- Sharpen or replace the blades
- Replace the blades
- Clean out the deck
- Repair or replace the deck
- Repair or replace the spindle
- Reinstall the blades correctly

Scalping

Scalping is when the mower deck comes close to or hits the ground. Scalping can be caused by the mower deck misadjustment, unevenness in the lawn, or by mower deck bouncing because the ground speed is too fast.

Scalping

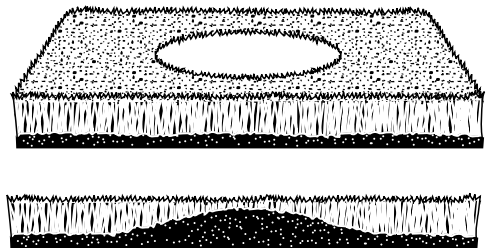

CAUSE

- Lawn is uneven or bumpy
- Mower deck cutting height is set too low
- Ground speed is too fast
- Deck is not leveled correctly
- Tire pressure is low or uneven

SOLUTION

- Roll or level the lawn
- Raise the cutting height
- Slow down
- Correctly level the deck
- Check and inflate the tires

Stingers

Stingers are sparse patches of uncut grass left behind the mower. Stingers are usually caused by operator error or poor blade maintenance.

Stingers

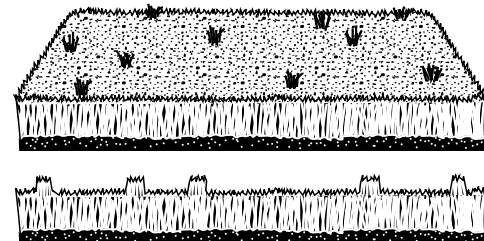









CAUSE

- Blades are not sharp or are nicked
- Blades are worn down too far
- Engine speed is too slow
- Ground speed is too fast
- Deck is plugged with grass

SOLUTION

- Sharpen your blades
- Replace your blades
- Always mow at full throttle
- Slow down
- Clean out the mower

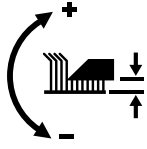
Common International Symbols

- | | | | |
|---|-----------------|---|---------------------------------|
|  | Choke |  | PTO Clutch |
|  | Fast (Throttle) |  | Parking Brake |
|  | Slow (Throttle) |  | Brake |
|  | Throttle |  | Mower Cutting Height Adjustment |
|  | Fuel |  | Headlights |

Technical Manuals

Additional Technical Literature Available



Operators Manuals

Additional copies of this manual are available, (and as part of our product support commitment, we maintain a stock of printed operators manuals going back many years!)

Parts Manuals

Fully illustrated parts manuals are also available — these manuals show all of the product's components in exploded views ("3D" illustrations which show the relationship of the parts and how they go together), as well as giving the replacement part numbers and quantities used. Important assembly notes and special torque values are included in these manuals.

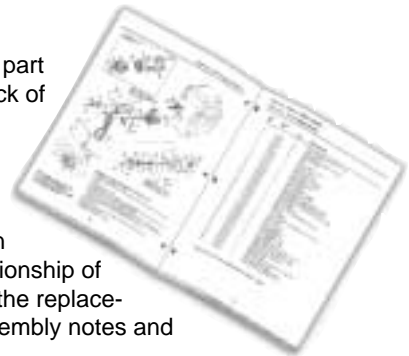

For the applicable manuals currently available for your model, contact your local dealer. Have the information listed in the box at the right available when making your request.

Model:	_____
Serial No.:	_____
Your Name:	_____
Address:	_____
City, State, Zip:	_____
Visa/Mastercard No.:	_____
Card Expiration Date:	_____

