

# *Simplicity*

## SYSTEM 7013S 'BARON'

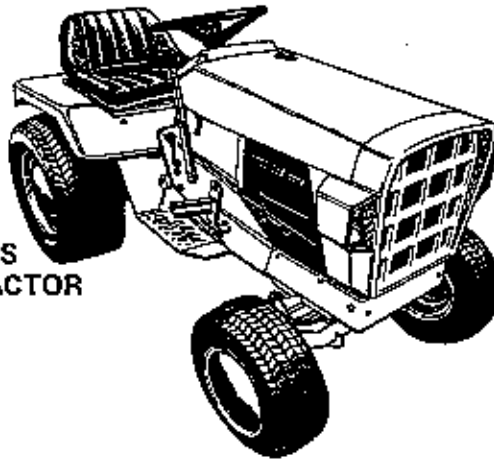

1690015 13 H.P. 7013S  
RIDING TRACTOR

# OPERATOR'S MANUAL

# OPERATION

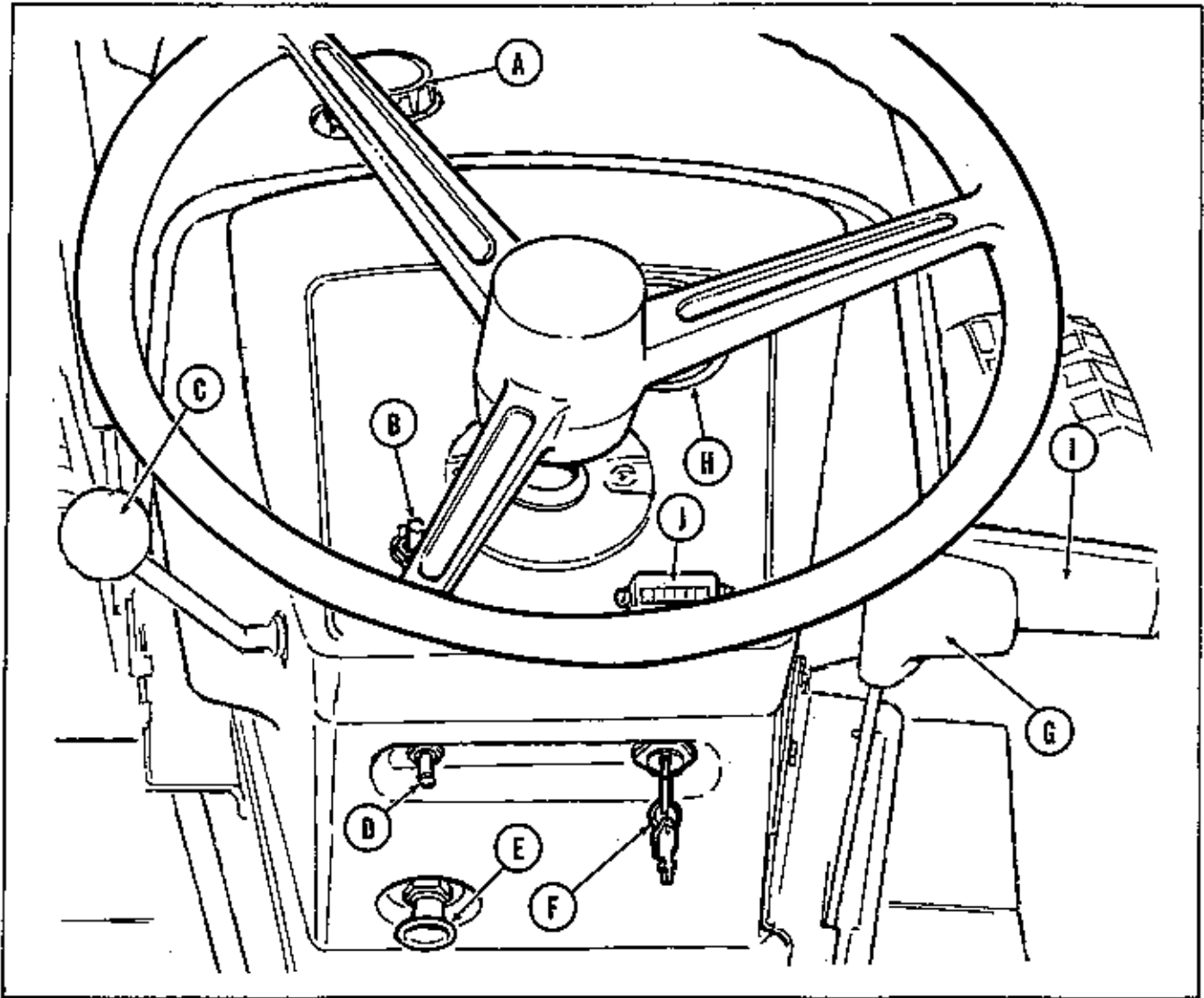

Figure 1. Tractor instrument panel as seen from the operators position on tractor seat.

## INSTRUMENTS AND CONTROLS-HOW TO UNDERSTAND AND USE THEM

Picture yourself seated on your tractor. Before starting the engine, lets learn how to understand and use the instruments and controls. The paragraphs referring to the instruments and controls are illustrated in figures 1 through 4.

**IGNITION SWITCH:** (Figure 1, item F) To actuate the ignition switch first insert the ignition key as shown. When the key is turned clockwise to the first position, the ignition is ON. In the ON position the lights, hourmeter, etc. will operate. Turn the key clockwise past the ON position to the START position to actuate the starter. **THE TRANSMISSION SHIFT LEVER MUST BE IN THE NEUTRAL POSITION AND THE POWER TAKE OFF CLUTCH CONTROL LEVER(S) MUST BE IN THE DISENGAGED POSITION BEFORE THE STARTER WILL ACTUATE.** Release the

key as soon as the engine starts. Return the key to the vertical position to stop the engine. **CAUTION: ALWAYS REMOVE THE IGNITION KEY WHEN CLEANING, ADJUSTING, OR SERVICING THE TRACTOR OR ANY ATTACHMENT OR WHEN LEAVING THE VEHICLE UNATTENDED.**

**CHOKE CONTROL KNOB:** (Figure 1, item E) The choke control knob may be pulled out to increase the amount of fuel entering the engine for starting and cold weather warmup. When starting a cold engine in cold weather pull the choke all the way out. Some choke may be required to start the engine when the air temperature is above 70 degrees F or while the engine is still warm from being recently run. After the engine has started, push the choke in slowly. In cold weather it may be necessary to leave the choke pulled out slightly for three or four minutes while the engine warms up. **NEVER OPERATE THE ENGINE WITH THE CHOKE OUT AFTER IT HAS HAD SUFFICIENT TIME TO**

**WARM-UP:** ABOUT 5 MINUTES SHOULD BE SUFFICIENT EVEN IN COLD WEATHER.

**AMMETER:** The dial pointer will move right to the "Charging" position when energy is being added to the battery and left to the "Discharge" position when energy is being drawn from the battery. The pointer will normally fluctuate to either side of the dial center. (Figure 1, item H)

**HOURMETER: (OPTIONAL)** (Figure 1, item J)  
The hourmeter is useful in keeping accurate maintenance records and telling how much time the tractor has been used on a particular job. It operates anytime the ignition is turned on whether the engine is running or not.

**FUEL GAUGE AND FILLER CAP:** (Figure 1, item A)  
The fuel gauge indicates fuel level. **BEFORE ADDING FUEL, SHUT OFF THE ENGINE AND ALLOW IT TO COOL SEVERAL MINUTES.** Turn the cap counterclockwise to remove it and add fuel. The 3 gallon capacity provides about 3 hours of mowing. Use leaded or non-leaded **REGULAR** grade automotive gasoline. **CAUTION: DO NOT ALLOW LIGHTED CIGARETTES, MATCHES, ETC., AROUND ANY OPEN GASOLINE CONTAINER. DO NOT OVERFILL; WIPE UP ANY SPILLED GASOLINE.**

**LIGHT SWITCH: (OPTIONAL)** (Figure 1, item D)  
The switch should be moved up to the ON position to turn on the tractor lights. To prevent the lights from being turned on by unauthorized persons, the ignition switch must also be in the ON position for the lights to operate. To turn the lights off, push the light switch down to the OFF position. **DO NOT OPERATE THE LIGHTS FOR LONG PERIODS OF TIME (MORE THAN 20 MINUTES) WHEN THE GENERATOR LIGHT IS ON OR THE BATTERY MAY DISCHARGE ENOUGH SO IT WILL NOT START THE ENGINE.**

**POWER LIFT SWITCH:** (Figure 1, item B)  
The power lift switch controls the electrically operated power lift unit. Push the toggle switch forward to raise a front, center or rear mounted attachment. Pull it back toward you to lower the attachments. The power lift will stop and hold in any position when you release the toggle switch. The height indicator (Figure 6, item A) on the left side of the tractor shows attachment position. The lift motor will ratchet when it has reached the end of its travel. Ratcheting is not harmful to the unit, but releasing the toggle switch as soon as ratcheting begins will prevent unnecessary wear. If the motor is allowed to ratchet for an extended period of time, a circuit breaker will open, disconnecting power to the lift motor. It will automatically reset after about a minute.

**CLUTCH AND BRAKE PEDAL:** (Figure 1, item I)  
Depressing the pedal will first disengage the transmission belt. As you continue to depress the pedal, the brakes will

be applied to stop the tractor. The clutch-brake pedal may be depressed for shifting transmission gears, but it is not necessary if the shuttle drive control lever (Figure 1, item G) is in the neutral position.

**SHUTTLE DRIVE CONTROL LEVER** (Figure 1, item G)  
The position of this lever determines whether the tractor moves forward or reverse or remains stationary. It can also be used for short periods of time to reduce tractor travel speed in either forward or reverse, or used to stop tractor travel by pulling it toward the opposite position.

Although the tractor may be shifted into or out of any gear by depressing the clutch-brake pedal, it may be shifted more rapidly by placing the shuttling control lever in the center **NEUTRAL** position as shown in figure 1. The brake which is automatically applied when this lever is in neutral, stops "spinning" of the transmission input shaft to facilitate shifting.

After shifting the four-speed transmission into the desired gear, the tractor can be driven **FORWARD** by pushing the shuttle drive control lever ahead and locking it in the forward position. To drive in **REVERSE** pull the shuttle drive control lever back and lock it in the reverse position. For a particular transmission gear, the tractor will drive the same speed in reverse as forward. The shuttle drive control lever may be moved from forward to reverse or reverse to forward without waiting for the tractor to stop moving. To prevent sudden change of direction and unnecessary wear to the clutches, the shuttle drive control lever should be moved slowly into either drive position.

The tractor may be "inched" or slowed for working in tight areas by holding the shuttle drive control lever part way toward the locked drive position. This can be done for short periods of time without damage, however, constant slipping of the drive clutches will cause them to wear and require frequent adjustment.

**SPEED CONTROL LEVER:** (Figure 1, item C)  
The engine speed control lever is used to set the desired engine speed. The speed control lever should be moved forward away from the operator to increase engine speed or back toward the operator to reduce engine speed. Consult the appropriate section of this manual for specific information on suggested settings of the engine speed control lever. For example: starting the engine, page 5. Controlling tractor ground speed page 5, and the Operation Chart on page 7.

**TRANSMISSION SHIFT LEVER:** (Figure 2, item A)  
The transmission shift lever is used to select the desired transmission gear. There are four drive positions. Using the shuttle drive unit, the tractor will move either forward or reverse in any of the gears. The approximate ground speed in miles per hour for each gear at full engine speed (3600 RPM) both forward and reverse are shown below:

GEAR	MAXIMUM GROUND SPEED
First	.96 MPH
Second	2.3 MPH
Third	3.7 MPH
Fourth	5.1 MPH

The diagram on the tractor frame shows the location of each position. To shift the transmission into first or third, push the shift lever forward and move it left or right to the de-

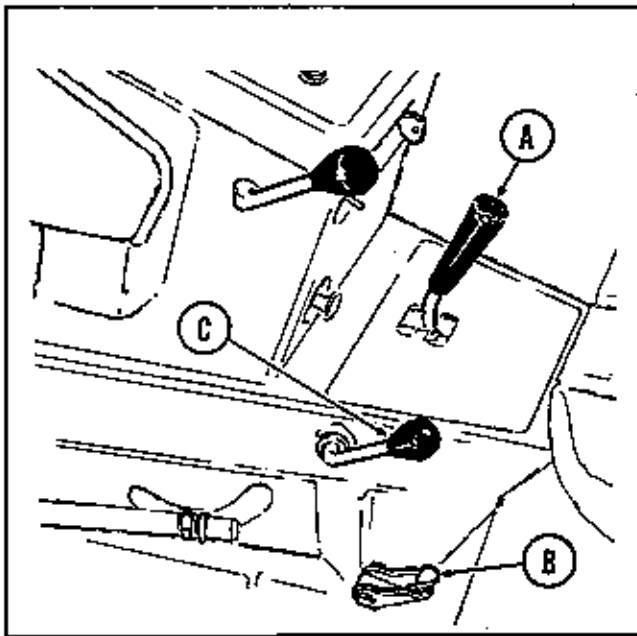

Figure 2. Controls seen from left side of tractor.

sired gear. To shift into second or fourth, pull the shift lever back toward you and move it to the left or right.

Do not attempt to move the shift lever unless tractor movement is stopped and either the shuttle drive control lever is in neutral or the clutch-brake pedal is depressed. The transmission shift lever must be in the neutral START position for the engine starter to operate.

**PARKING BRAKE LOCK:** (Figure 2, item B) To lock the parking brake, grasp the lock and pull it upward and back until the handle rests against the footrest as shown in figure 2. To release pull the top portion away from the footrest and down. It should be locked in the up position to prevent the tractor from rolling whenever the operator leaves the tractor seat. Remember to release the parking brake before driving the tractor.

**POWER TAKE OFF CONTROL LEVER:** (Figure 2, item C) This lever controls power to center or rear mounted attachments such as a mower or rotary tiller. Pull the lever up and move it forward until it snaps over center to engage the power take off. Pull it back and down to disengage. Always move the power take off control lever all the way to the disengaged or engaged position. The tractor engine should be running at 1/2 to full engine speed when the power take off is engaged to absorb the added load. **CAUTION: ALWAYS DISENGAGE THE POWER TAKE OFF, AND WAIT UNTIL ALL ATTACHMENTS HAVE STOPPED MOVING BEFORE LEAVING THE TRACTOR SEAT.** The power take off control lever must be disengaged before the engine will start.

**MANUAL LIFT LEVER:** (Figure 3, item A) The lift lever is used for raising or lowering attachments such as the rotary mower or the tiller for transport. The operating height of attachments, can be regulated by using the notches and pin holes provided. The thumb button (B) on top of the handle disengages the catch from the quadrant so the

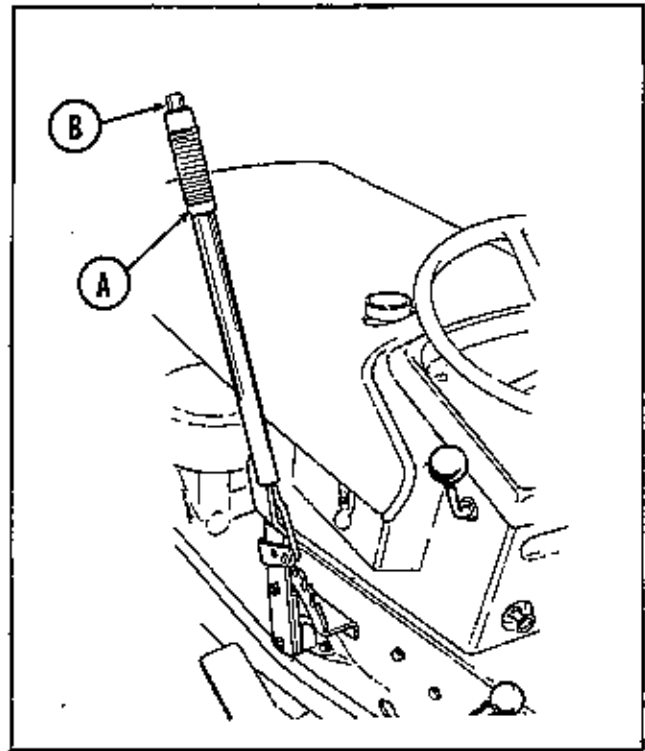

Figure 3. Controls on left side of tractor.

lever can be moved as desired and locked into position. See the owners manual for any attachment you may be using for specific information on how the lift lever should be used.

**DUAL LIFT LEVER: (OPTIONAL)** (Figure 4, item A) The dual lift lever provides a convenient means of operating a front mounted attachment such as a snow

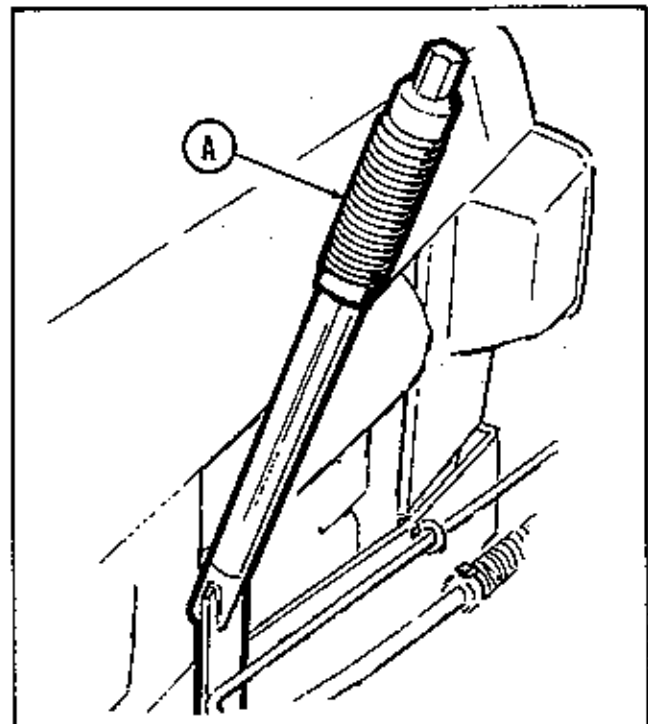

Figure 4. Dual lift lever.

thrower or a snow plow and dozer blade independently of center or rear mounted attachments. A good example is using the rotary tiller and dozer blade in leveling a ground surface. Both attachments can be mounted to the tractor at the same time, and the operator can conveniently raise or lower each of them from the tractor seat.

## BEFORE OPERATING THE TRACTOR

Though your Dealer may have performed the before starting checks listed below we suggest that you personally check each one so that you will become familiar with them and also to insure that your tractor is ready to operate the first time you use it.

**TIRE INFLATION:** The tires should be checked and inflated to the proper pressure before operating. Front tires should have 12 to 15 PSI of air and rear tires 6 to 8 PSI of air.

**CRANKCASE OIL:** Before starting the engine, insure the engine crankcase is filled with the correct grade and weight of oil. See page 15 in the Maintenance section of this manual for instructions on checking the oil and the correct oil to use.

**FUEL SUPPLY:** Fill the fuel tank completely with clean fresh leaded or non-leaded regular grade automotive gasoline. (Do not mix oil with gasoline). Premium gasolines are not recommended as they increase carbon deposits in the engine. **CAUTION: GASOLINE IS HIGHLY FLAMMABLE. NEVER ALLOW ARTICLES SUCH AS LIGHTED MATCHES, OR CIGARETTES, WHICH COULD CAUSE IT TO IGNITE NEAR OPEN GASOLINE CONTAINERS. DO NOT OVERFILL. WIPE UP ANY SPILLED FUEL. BE SURE THE ENGINE IS NOT RUNNING AND HAS BEEN ALLOWED TO COOL BEFORE ADDING FUEL.**

**BEVEL GEAR BOX OIL:** See figure 31. Remove the pipe plug dipstick (A) from the top of the bevel gear box. Check oil level. If oil is low add 90 weight transmission oil as needed.

**AIR CLEANER:** Insure that the air cleaner is in place and properly sealed. If it is dirty, clean or replace it according to the instructions on page 15, in the Maintenance section of this manual.

**BATTERY:** Check the battery to be sure it is filled to the proper level with electrolyte and the vent holes in each of the filler caps are open. See page 18 in the Maintenance section of this manual.

**TRANSMISSION OIL:** See figure 30. Remove the pipe plug (A) to check the oil. The oil should be level with the bottom of the threads. If it is not, add 90 weight transmission oil until it is level with the bottom of the hole threads.

**LUBRICATION:** Lubricate all grease zerks and pivot points according to the Every 25 Hour Maintenance instructions on page 14 of this manual. A pisto-luber grease

gun special designed for this purpose is available from your dealer.

**ATTACHMENTS:** Read and become familiar with the Owners Manual for any attachments you are using with your tractor.

**SEAT ADJUSTMENTS:** The seat should be adjusted so the operator can comfortably depress the clutch and brake pedals while sitting back in the seat. See page 9 in the Adjustment section of this manual if the seat requires adjusting.

## STARTING THE ENGINE

1. Refer to the Instruments and Controls section beginning on page 2 of this manual for the location and use of the instruments and controls. **CAUTION: IT IS DANGEROUS TO START THE TRACTOR UNLESS YOU ARE SEATED IN THE TRACTOR SEAT.** Insure that the power take off clutch control lever (s) are in the disengaged position, and the transmission shift lever is in the neutral/START position.
2. Move the engine speed control lever to midway between slow and fast.
3. Pull the choke knob out. In cold weather pull it all the way out. In warmer weather or when starting an engine which is still warm from recent operation less choke will be required.
4. Depress the clutch brake pedal and hold it down to disengage the transmission drive. Although the engine may be started without disengaging the clutch, in cold weather it will start easier with the clutch disengaged since the starting motor will not have to turn the transmission in addition to the engine.
5. Insert the ignition key and turn it to the right past the ON position to the START position to actuate the starter motor. As you turn the key, check the Ammeter to see if it is functioning properly. See page 3 Ammeter.
6. When the engine starts, release the key and allow it to return to the ON position. Slowly push the choke in. After the engine has run for a few minutes it should not require any choking. If the engine does not start after about 10 seconds of cranking it may be receiving too rich a fuel mixture. Push the choke in and try again. The engine may not need to be choked when starting it in warm weather or if it has been operated recently.
7. Release the clutch brake pedal as soon as the engine is running smoothly.

## STOPPING THE ENGINE

1. Move the engine speed control lever to the SLOW position.
2. If the tractor has been operating under full load, allow the engine to idle for about a minute to reduce the engine temperature. Stopping a hot engine too suddenly can damage engine parts.
3. Turn the ignition key counter-clockwise to the vertical position to stop the engine.
4. Set the parking brake.
5. Remove the ignition key to prevent unauthorized use of the tractor.

## CONTROLLING TRACTOR GROUND SPEED

Tractor ground speed can be controlled by the position of

the transmission shift lever and/or the engine speed control lever or for short periods by the shuttling drive lever.

### ENGINE SPEED

Attachments driven by the power take off operate best at a particular speed. The engine speed control should be adjusted to set the attachment speed for the operation being performed and the tractor transmission used to control travel speed. The engine speed control is one means for controlling ground speed when pulling light loads or transporting the tractor.

### TRANSMISSION SHIFT LEVER

See the chart on page 7 for selecting the gear recommended for performing various jobs.

Operations such as snow throwing or lawn revitalizing can be performed more quickly by using a low forward speed and higher reverse speed. First and third gears are opposite each other and it is simple to "flip shift" with the shuttling speed control in neutral using first for forward and third for reverse.

### STARTING TRACTOR TRAVEL

Assure yourself that the area in which you are going to drive the tractor is free of obstructions. Insure the shuttle drive control lever is in the **NEUTRAL** position, then shift the four-speed transmission into the desired gear. It is not necessary to depress the clutch-brake pedal to shift gears if the shuttle drive control lever is in the neutral position.

Release the parking brake and look around to insure there are no obstructions in your path. To start the tractor in motion, move the shuttle drive control lever **SLOWLY** forward or back from the neutral position until it locks in the forward or reverse position.

### STOPPING TRACTOR TRAVEL

Tractor motion may be stopped either with the shuttle drive control lever or the clutch-brake pedal. To stop the tractor forward travel use the shuttle drive control lever, move the lever to the **NEUTRAL** position and then slowly toward the **REVERSE** position. As soon as the tractor stops moving, place the shuttle drive control lever in neutral. If you wish to stop the tractor while it is moving in reverse, push the shuttle drive lever past neutral slowly toward the forward position.

In emergencies or if both hands are required on the steering wheel, depress the clutch-brake pedal to stop the tractor. Before leaving the tractor seat, shut off the engine, set the parking brake, and remove the ignition key.

### HOT WEATHER OPERATION

When operating the tractor at temperatures above 75°F pay particular attention to the following items to prevent damage.

1. Keep the engine cooling fins and fan screen clean and free of obstruction which would decrease air flow to and from the engine. See page 14 for cleaning instructions.
2. Insure that you are using the proper grade and weight of oil in the engine for the temperature where the tractor is being used. Check the oil level each time you fill the fuel tank.

### DO NOT OVERFILL THE CRANKCASE - ENGINE OVERHEATING MAY RESULT.

3. Check the battery water level more frequently than every 25 hours which is recommended under normal conditions. High temperatures cause faster evaporation of water from the battery.
4. Remove the carburetor heat deflector used with the snow thrower or dozer blade.

### COLD WEATHER OPERATION

When the tractor is being used in temperatures below 30°F, check the following items closely:

1. Use the correct grade and weight of oil for the temperature conditions. Change the oil only when the engine is warm. If an unexpected temperature drop occurs when the engine is filled with summer oil, before starting the engine, move the tractor to a warm location until the oil will flow freely.
2. Use fresh fuel. Fill the fuel tank after each days use to protect against moisture condensation.
3. Disengage the clutch when starting the engine.
4. Install the heat deflector furnished with the snow thrower or dozer blade if these attachments are to be used.

### DUSTY OPERATING CONDITIONS

When the tractor is operated in dusty or dirty conditions check the following items closely:

1. Keep the engine fan screen and cooling fins clean and free of materials which will decrease air flow.
2. Service the air cleaner more frequently. Clean or replace it as often as necessary to allow air to flow to the carburetor freely.
3. Change the engine oil more frequently. The oil should be changed more often than every 25 hours as is recommended under normal conditions. In extremely dusty conditions, change every 10 operating hours.

### OUT OF SERVICE PROTECTION (Storage)

When the tractor is to be stored without use for a month or longer, the following precautions should be taken to insure your tractor will be ready to go when you need it:

1. Unless you wish to run the tractor until the fuel tank is empty, add a good brand of gasoline stabilizer. This additive, Stabil, available from your dealer, prevents formation of gum and varnish for up to one year, providing easier starting and a cleaner fuel system.
2. Drain and refill the engine crankcase while the engine is warm. Tie a tag on the tractor indicating what grade and weight of oil was used.
3. Remove the spark plug and pour one ounce (two tablespoons) of SAE 30 engine oil into the cylinder. Engage the starter to turn the engine over a few times, then reinstall the spark plug.
4. Clean the air cleaner element as described on page 18, of the Maintenance instructions.
5. Plug the exhaust outlet to prevent the entrance of moisture, dirt, bugs, etc.
6. Insure the battery is filled to the proper level with water and is fully charged. Battery life will be increased if it is removed and put in a cool dry place and fully charged about once a month.
7. Grease all grease zerks and put oil on the lubrication points

shown in the Maintenance section.

8. If the tractor is to be stored 6 months or longer block the tractor up off the wheels to relieve weight and keep the tires off a damp floor. Protect the tires from prolonged exposure to direct sunlight.

9. Store the tractor in a dry place indoors.

## STARTING THE TRACTOR AFTER STORAGE

Before starting the tractor after storage, do the following:

1. Remove the blocks from under the tractor.
2. Replace the battery.
3. Unplug the exhaust outlet.
4. Perform the Before Operating instructions on page 5.

Attachment	Engine Speed Control	Transmission Gear Selection	Approx. Ground Speed (MPH)	Required Accessories and Options	Recommended Accessories and Options
Transporting Tractor		1 — 3 2 — ④	3 - 5		
42" or 48" Rotary Mower (Smooth terrain - normal grass)		1 — 3 2 — ④	4 - 5		2 Rear wheel weights when mowing slopes 20-40%, mowing slopes greater than 40% not recommended.
42" or 48" Rotary Mower (Rough terrain - heavy or wet grass)		1 — ③ ② — or — 4	3 - 3.5 or 2 - 2.3		2 Rear wheel weights when mowing slopes 20-40%, mowing slopes greater than 40% not recommended.
46" Sickle Bar		1 — ③ 2 — or — ④	2.5 - 3.5 or 3 - 5		2 Rear wheel weights when mowing slopes 20-40%, mowing slopes greater than 40% not recommended.
38" Lawn Revitalizer		① — 3 ② — or — 4	.8 - .96 or 1.5 - 2.3	Rear lift kit.	Power lift kit.
36" or 42" Snow Thrower (Light Snow)		1 — ③ 2 — 4	2 - 3.5		Power lift kit. Tire chains. 4 Rear wheel weights. 2 Front wheel weights.
36" or 42" Snow Thrower (Heavy or wet snow)		① — 3 2 — 4	.5 - .96		Power lift kit. Tire chains. 4 Rear wheel weights. 2 Front wheel weights.
42" or 46" Snow Plow and Dozer Blade		1 — ③ 2 — or — ④	2 - 3.5 or 4 - 5		Tire chains. 4 Rear wheel weights. 2 Front wheel weights. Power lift kit.
42" Grader Blade		1 — ③ 2 — or — ④	2 - 3.5 or 3.5 - 5		4 Rear wheel weights.
36" Rotary Tiller		① — 3 2 — 4	1	Rear lift kit.	4 Rear wheel weights. 2 Front wheel weights. Power lift kit
10" Mounted Plow		1 — 3 ② — 4	2	Rear lift kit.	4 Rear wheel weights. 2 Front wheel weights. Power lift kit.
Cultivator or Planter		1 — ③ 2 — 4	2 - 3	Rear lift kit.	4 Rear wheel weights. 2 Front wheel weights. Power lift kit.
Spring Tooth Harrow		1 — ③ 2 — 4	2 - 3.5	Rear lift kit.	4 Rear wheel weights. 2 Front wheel weights. Power lift kit.

REFER TO YOUR ATTACHMENT OWNERS MANUALS FOR ADDITIONAL INFORMATION.

Figure 5. Operation chart.

## TROUBLE SHOOTING GUIDE

PROBLEM OR SYMPTON	POSSIBLE CAUSES	CHECKS AND CORRECTIONS
Starter will not turn engine over.	Transmission shift lever not in neutral position. Power take off not disengaged. Battery discharged or dead. Circuit breaker tripped. Neutral safety start switch not properly adjusted. Wiring loose or broken.  Battery terminals corroded.	Move transmission shift lever to neutral start position. Move control lever (s) to disengage position. Check the battery - charge or replace as necessary. Wait a minute for circuit breaker to reset. Adjust the safety switch for the transmission. See page 12. Visually check wiring, replace any broken or frayed wires, tighten loose connections. Clean battery terminals.
Engine turns -- will not start.	Out of fuel. Engine flooded. Crankcase oil too heavy. Fuel filter plugged. Water in gasoline. Spark plug worn or dirty.	Fill fuel tank. Push choke in, attempt to start. Change oil as recommended on page 15. Replace fuel filter. See page 18. Drain fuel tank, replace fuel filter. Check and replace or set. See page 19.
Engine starts hard or runs poorly.	Fuel mixture too rich.  Fuel mixture too lean or too rich. Spark plug, worn or dirty.	Push choke in. Clean air filter element. See page 18. Adjust carburetor. See page 13. Check and replace or set. See page 19.
Engine knocks.	Not enough oil in crankcase. Using wrong weight of oil.  Using wrong grade of gasoline.	Add oil as required. See page 14. Change oil, use weight recommended for weather conditions. See page 15. Use regular grade automotive gasoline.
Tractor drive clutch will not disengage.	Too much clutch free travel.  Belt stop not properly adjusted.	Adjust clutch pedal free travel. See page 10.  Adjust belt stop. See page 10, Clutch free travel.
Engine will not idle smoothly.	Air Cleaner dirty. Water in fuel tank. Carburetor fuel mixture set incorrectly. Spark plug worn or not set properly.	Clean or replace air cleaner. See page 18. Remove fuel tank to drain, replace fuel filter. Adjust carburetor. See page 13.  Adjust or replace. See page 19.
Excessive oil consumption.	Engine running too hot. Using wrong weight of oil. Too much oil in crankcase.	Clean engine fins and fan screen. See page 14. Change to correct weight oil. See page 15. Check oil level according to instructions on page 14.
Exhaust is black or smoky.	Air filter element dirty. Fuel mixture too rich.	Clean or replace filter element. See page 18. Be sure choke opens fully when it is pushed way in. Set carburetor adjustment. See page 13.
Engine runs, tractor will not drive or drive with full power.	4 - Speed transmission not in gear. Parking brake ON. Shuttle drive clutches need adjusting. Main drive belts are slipping.	Put 4 - speed transmission in gear.  Release parking brake. Adjust shuttle drive. See page 10.  Adjust clutch belt tension and free travel. See page 10.
Tractor creeps forward or back with shuttle control in Neutral.	Shuttle drive linkage out of adjustment.	Adjust shuttle drive. See page 10.
Brake will not hold.	Brakes need adjusting. Worn brake linings.	Adjust brake linkage. See page 11. Have your dealer replace linings.
Tractor drive clutch will not engage.	Too little clutch-free travel.	Adjust clutch free travel. See page 10.
Tractor handles poorly.	Steering linkage or front axle loose. Tires not properly inflated.  Wheels are spinning or slipping.  Moving too fast on sloping surfaces.	Tighten any loose connections.  Inflate tires correctly. Six to eight pounds in rear and 12 - 15 pounds in front. Use weights to provide additional stability and traction. Reduce speed.
Power lift will not operate.	Ignition switch may not be on. Circuit breaker may have cut out. Loose or broken wiring.	Turn ignition switch on. Wait a minute for circuit breaker to reset. Check and repair wiring.
Drive belt slips.	Belt stretched or worn. Pulleys may be greasy or oily. Too little clutch free travel.	Replace with correct belt. Clean with non-flammable solvent. Adjust free travel.



# ADJUSTMENTS

Most of the adjustments described here are easy to perform. Some of the adjustments require a little mechanical know-how and some special tools to do them well. You may wish to have your dealer make some or all of the adjustments as they are required; however, we have given instructions for them here as a convenience to you should you wish to make them yourself. **CAUTION: DO NOT ATTEMPT TO MAKE ANY ADJUSTMENTS WHILE THE ENGINE IS RUNNING UNLESS REQUIRED IN THE INSTRUCTIONS. IF THE ENGINE MUST BE RUNNING TO MAKE AN ADJUSTMENT, BE CAREFUL TO STAY CLEAR OF ANY MOVING PARTS.**

This tractor has been designed for easy accessibility to the areas which need to be reached in making adjustments and performing maintenance. The underside of the frame is open to provide easy access to areas requiring lubrication, adjustment, or repair.

## RAISING THE TRACTOR HOOD

See figure 6. The tractor hood is hinged at the front by two spring loaded bolts. It may be easily opened by releasing the two rubber straps (B) located on either side of the hood. Pull down and out on the straps to release them. Lift upward on the back of the hood to raise. The hood raised in this position provides easy access to the generator, battery, fuel tank, engine, etc.

## RAISING THE SEAT DECK

See figure 7. The tractor seat deck (A) is hinged at the back. To raise the seat deck, reach under it from each side and pull the two locking levers (B) to the outside. As you hold the locks out raise the seat deck as shown in figure 8. Raising the seat deck in this manner will expose many of the transmission adjustment and maintenance areas.

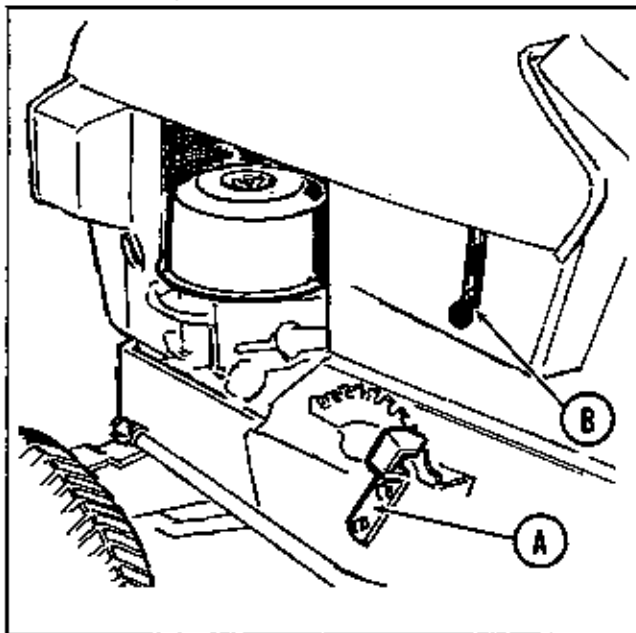

Figure 6. Left side of tractor

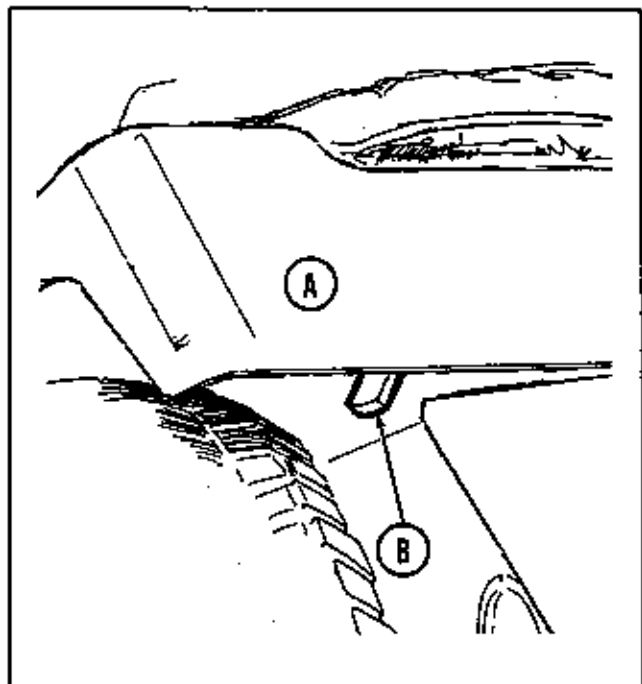

Figure 7. Seat deck release at front of seat deck.

## SEAT ADJUSTMENT

See figure 8. The tractor seat is properly adjusted when the operator can comfortably operate the clutch and brake pedal while sitting back in the seat. The seat can be adjusted forward or back in any of four positions. If adjustment is required, proceed as follows:

1. See figure 8. Position the seat deck as shown by following the instructions under Raising the Seat Deck on page 9.
2. Remove the two cap screws and lock washers at (A).
3. Remove the two nuts and lock washers at (B).
4. If the seat is to be positioned in either of the two forward sets of mounting holes the two rubber spacers are placed over the studs at (B) and used between the seat and seat deck. If the seat is to be positioned in either of the two

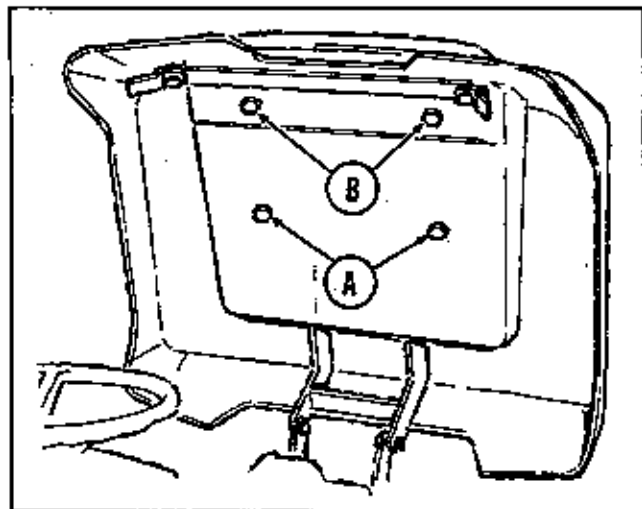

Figure 8. Seat deck raised.

rearward positions, the rubber spacers are placed over the studs (B), but under the seat deck. Line the seat up with the desired holes in the seat deck, and install the rubber spacers according to the holes used.

5. Install the two lock washers and nuts at (B) and tighten them securely.
6. Install the two cap screws and lock washers at (A) and tighten them securely.
7. Lower the seat deck.

### CLUTCH FREE TRAVEL

See figure 9. The clutch free travel is correct when there is  $1/4''$  between the nuts (A) and the rod guide when the clutch brake pedal is released and pulled rearward as far as it will go. If adjustment is required, proceed as follows:

1. Raise the seat deck as shown in figure 8, by following the instructions under Raising the Seat Deck on page 9.
2. Using two wrenches hold the forward nut at (A) stationary with one wrench while turning the rearward nut counter-clockwise slightly with the other to separate them.
3. Pull rearward on the clutch brake pedal to insure it has returned completely to the engaged position.
4. Turn the forward nut at (A) as necessary so that the distance between it and the rod guide is  $1/4''$  as shown in figure 9.
5. Using two wrenches hold the forward nut at (A) stationary while turning the rear one clockwise to tighten the two nuts together securely.
6. See figure 12. Check belt stop (A) and adjust it if necessary so it does not rub the drive belt when the clutch brake pedal is released. When the clutch brake pedal is depressed, belt stop (A) should pick up the drive belt to aid in disengaging it. If adjustment is required, loosen nut (B) slightly. Be sure to tighten nut (B) securely after the adjustment is completed.
7. Lower the seat deck.

### SHUTTLE DRIVE ADJUSTMENT

If the tractor does not drive with full power in either forward or reverse, creeps (moves slowly forward or backward) when the shuttle drive control lever is in neutral, or does not shift into gear without grinding, the shuttle drive may need adjusting. Proceed as follows:

1. With the engine stopped, raise the tractor seat deck by following instructions under Raising the Seat Deck on page 9.
2. Center the shuttle drive control lever (figure 1, item G) in the neutral position as shown.
3. See figure 9. Loosen set screw (B). Slide brake detent (C) forward or back as necessary to center it on brake pin (D). Tighten set screw (B) securely.
4. Push shuttle drive control forward until it latches in the forward position. (figure 1, item G).
5. See figure 10. Loosen nut (E) and turn brake pad (F) so there is  $1/8''$  clearance between the brake pad and the drive pulley. Tighten nut (E) securely.
6. See figure 10. Use the following procedures to adjust the forward clutch.
  - a. See figure 1. Position the shuttle drive control lever (G) in NEUTRAL as shown.
  - b. See figure 10. Loosen the set screw in collar (A). Push the rod guide assembly (B) forward until slack is removed from the forward drive belt (C).

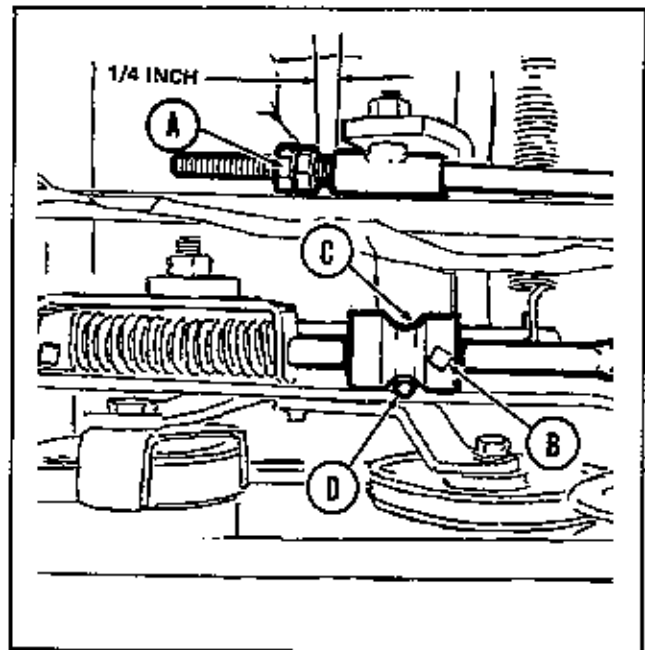

Figure 9. Clutch free travel and shuttle drive adjustment.

- c. While holding rod guide assembly (B) forward, tighten the set screw in collar (A).
- d. Lock the shuttle drive control lever (Figure 1, item G) in the forward drive position.
- e. See figure 10. The distance (D) between the rod guide and collar (A) should be  $1/8''$  to  $3/16''$ . If it is not, repeat steps a. through d. until distance (D) is  $1/8''$  to  $3/16''$ . Place more tension on belt (C) to increase distance (D) or less tension to decrease the distance.
7. Place the shuttle drive control lever in the NEUTRAL position.
8. See figure 11. Remove the cotter pin from swivel (A) and pull swivel (A) out of hole (B). Rotate swivel (A) until all slack is removed from brake band (C) when swivel (A) is placed through hole (B).
9. Install the cotter pin in swivel (A) to hold it in position through hole (B).

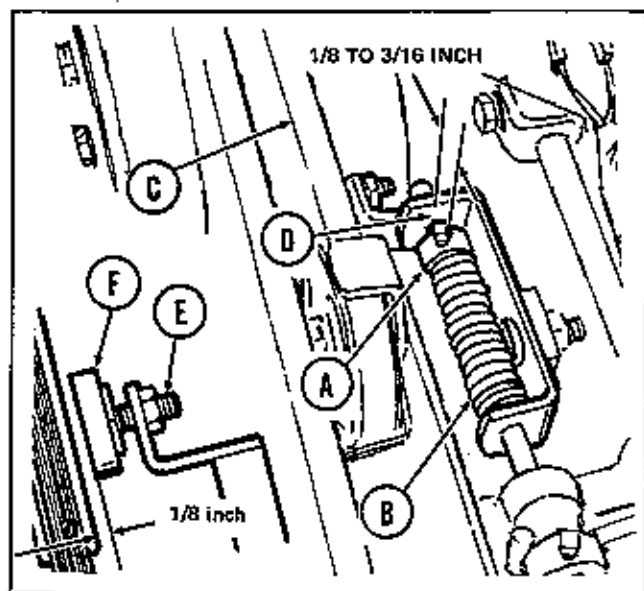

Figure 10. Shuttle drive forward adjustment.

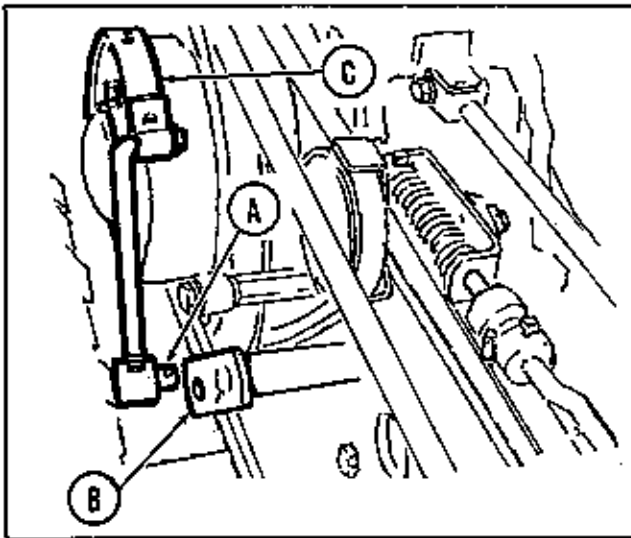

Figure 11. Shuttle drive adjustments.

10. See figure 12. With the shuttle drive control lever locked in the forward drive position, belt stop (C) should be positioned so there is 1/16" to 1/8" clearance between each leg of it and the clutch belt. If adjustment is necessary, loosen nut (D) slightly. Tighten nut (D) securely after the adjustment is completed.

11. Lower the seat deck. Start the engine and drive the tractor to check your adjustment. If the shuttle drive does not operate correctly, locate the problem noted below and make the correction indicated.

Will not pull forward with full power. Repeat adjustment step 6 placing more tension on the clutch belt. (figure 10, item C).

Tractor creeps forward when control lever is in neutral. Repeat step 6 placing less tension on the clutch belt. (figure 10, item C).

Will not pull with full power in reverse. Repeat steps 7 through 9 tightening brake band (figure 11, item C) more than previously.

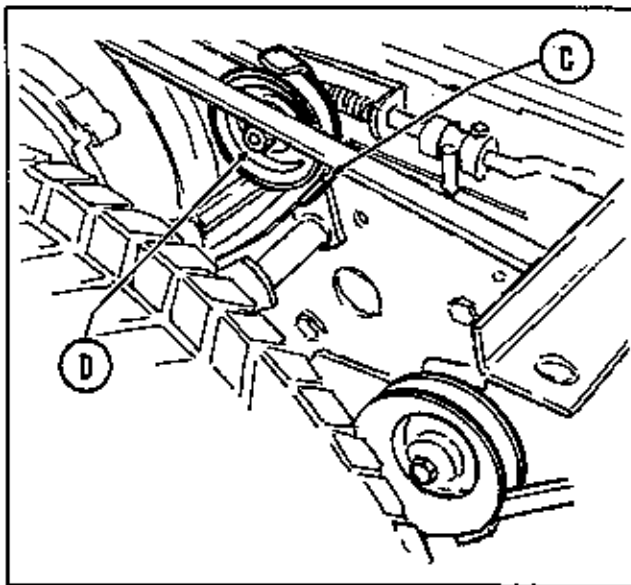

Figure 12. Belt stop adjustments located under seat deck.

Tractor creeps rearward when control lever is in neutral. Repeat steps 7 through 9 placing less tension on the brake band (figure 11, item C) than before.

Cannot shift gears without grinding when shuttle control lever is in neutral. Repeat steps 2 through 5.

## FOOT PEDAL BRAKE ADJUSTMENT

The foot pedal brake should be adjusted so that it will stop the tractor when it is moving backward, but not so tight to prevent the foot pedal from traveling far enough to disengage the clutch. If adjustment is required proceed as follows:

1. See figure 13. Use one open end wrench to hold nut (A) stationary, and another wrench to turn nut (B) counter-clockwise to loosen it slightly.

2. Turning nut (A) clockwise will give more braking action and turning it counter-clockwise will give less. The brake adjustment can best be made by using the trial and error method, and operating the tractor each time an adjustment has been made. The best adjustment can be made by turning nut (A) counter-clockwise until the foot pedal brake does not work. Then turning it clockwise, one turn at a time, until the tractor will stop satisfactorily when rolling backward. This is the correct adjustment. Further tightening may cause the brake to drag, or prevent proper clutch disengagement.

3. After you are satisfied that the adjustment is correct use one wrench to hold nut (A) stationary and another turn nut (B) clockwise to tighten the nuts securely together.

## PARKING BRAKE ADJUSTMENT

Although the transmission may help prevent the tractor from rolling when it is in gear and the engine is stopped, the parking brake should be properly adjusted and used whenever the operator leaves the tractor seat. The parking brake is actua-

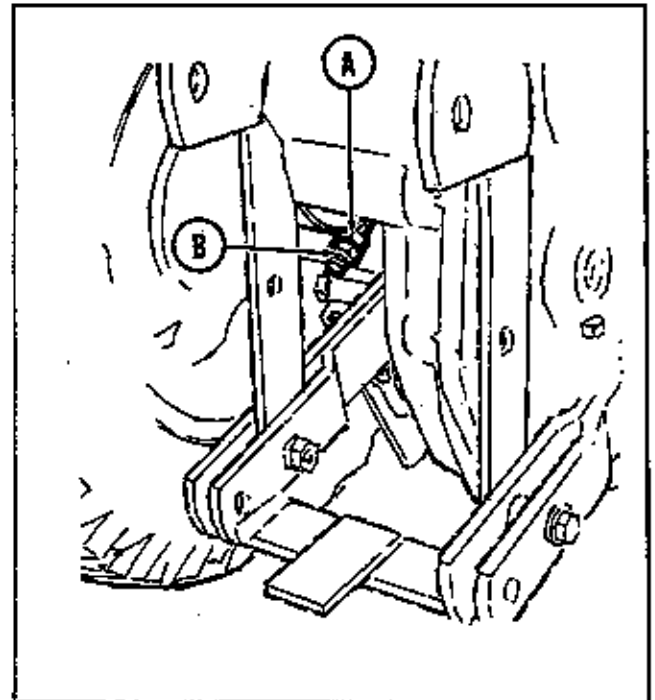

Figure 13. Brake adjustment near left rear wheel.

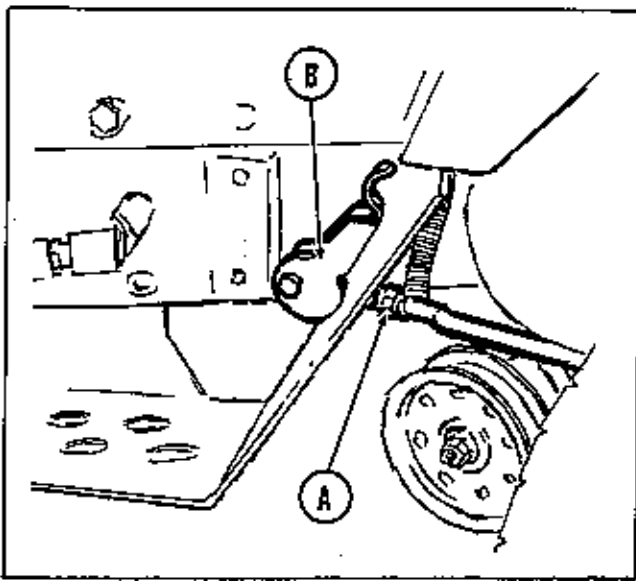

Figure 14. Parking brake adjustment on left side of tractor.

ted and adjusted independently of the foot brake. It is correctly adjusted when it will prevent the tractor from rolling either forward or backward and some resistance is felt when it is placed in the engaged position. If it is too tight, it will be difficult to place it in the engaged position. To adjust the parking brake, proceed as follows:

1. See figure 14. **NOTE: ALL DIRECTIONS GIVEN FOR ADJUSTING THE PARKING BRAKE, ARE AS IF YOU ARE STANDING AT THE FRONT OF THE TRACTOR LOOKING BACK TOWARD THE PARKING BRAKE.** Loosen nut (A) by turning it clockwise.
2. See figure 14. After insuring the tractor is either on a level surface or the wheels are blocked so it will not roll, pull forward on the parking brake handle (B) to disengage the parking brake.
3. Rotate parking brake handle (B) clockwise to tighten the parking brake, or counter-clockwise to loosen it. Turn the brake one complete revolution when making any adjustment. After turning the handle (B) one revolution place it in the engaged position to check it for correct adjustment. The correct engaged position is as shown in figure 14, with the handle at approximately the one o'clock position as you face it from the front of the tractor.
4. After the correct adjustment has been made, use a wrench to tighten nut (A) securely by turning it counter-clockwise.

## TRANSMISSION NEUTRAL SAFETY START SWITCH

If the engine starter will not actuate when the transmission shift lever is in neutral position or will actuate when the transmission shift lever is not in the neutral position, the neutral safety starting switch may need adjusting. Be sure power takeoff lever (s) is disengaged. Adjust transmission safety start switch as follows:

1. Raise seat deck (page 9).
2. Place transmission shift lever in the neutral START position.
3. See figure 15. Adjust carriage bolt (A) to proper height so switch (C) will make contact when transmission is in

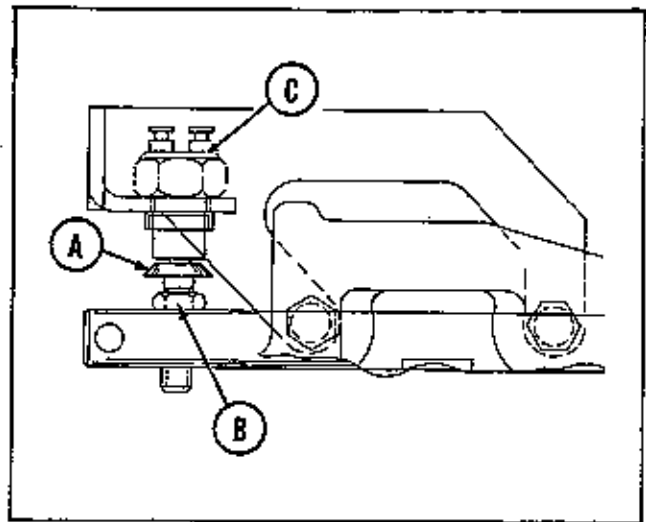

Figure 15. Neutral safety start switch located under seat deck.

neutral START position.

4. Tighten hex nut (B) against shift rod.
5. Lower seat deck and check adjustment by starting tractor.

## POWER TAKE-OFF CLUTCH ADJUSTMENT

See figure 16. The power take off clutch is properly adjusted when pulley (A) moves 1/8" when the power take off control lever is engaged and disengaged. If adjustment is required, proceed as follows:

1. Raise the seat deck, by following the instructions on page 9 under Raising the Seat Deck.
2. Place the power take off clutch control lever (figure 2, item C) in the engaged position.
3. Observe the movement of pulleys (A) in relation to cup (B) as the power take off control is moved slowly from the engaged to disengaged position. If the pulleys (A) move more or less than 1/8", adjustment is required.

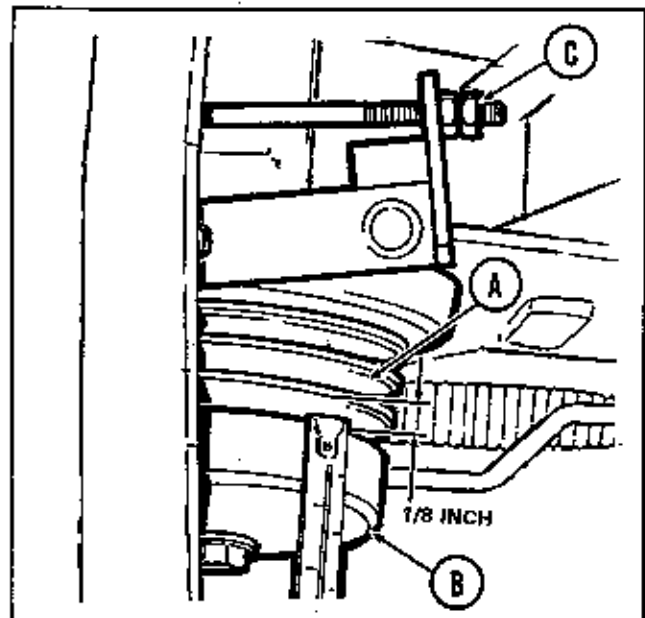

Figure 16. Power take off clutch.

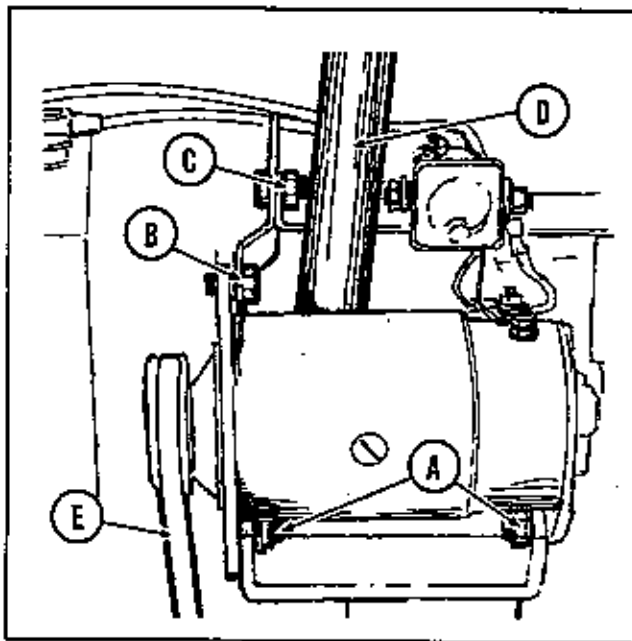

Figure 17. Generator located on right side of engine.

4. Turn the rear most nut at (C) counter-clockwise to loosen it slightly. To increase the amount pulley (A) travels turn the nuts at (C) clockwise. To decrease travel of pulley (A), turn the nuts counter-clockwise. Adjust the nuts at (C) and observe the travel of pulleys (A) as the power take off lever is engaged and disengaged. When adjustment has been made so the pulley (A) travels  $1/8''$  tighten the rear most nut at (C) against the forward nut to lock them in place.
5. Recheck your adjustment.
6. Lower the seat deck.

### STARTER-GENERATOR BELT ADJUSTMENT

See figure 17. If the starter turns, but the engine does not rotate, the starter generator belt may need tightening. Proceed as follows:

1. Raise the tractor hood as explained on page 9 under Raising the Tractor Hood.
2. See figure 17. Loosen slightly the two nuts (A) cap screw (B) and nut (C). Use a pry bar (D) similar to the one shown between the generator and engine block to apply pressure to the generator and tighten the belt. The belt should be tight enough so thumb pressure at (E) will deflect it about  $1/4''$ .
3. While holding the pry bar to maintain tension on the belt, tighten the mounting bracket at (C) securely.
4. Actuate the starter to make sure the engine will rotate. If it does not, loosen the nut at (C) and apply more tension to the belt.
5. Tighten the two nuts at (A) and the cap screw (B) securely.

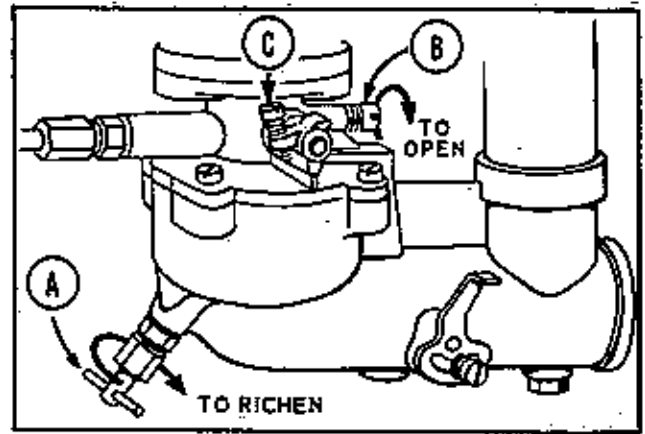

Figure 18. Carburetor adjustments.

6. Lower the hood and lock it in place.

### CARBURETOR ADJUSTMENT

The carburetor is adjusted at the factory and normally does not need adjustment unless it has been disassembled or tampered with.

#### INITIAL ADJUSTMENT

Initial adjustment will permit the engine to be started and warmed up prior to final adjustment. Proceed as follows:

1. See figure 18. Turn the needle valve (A) clockwise until it just closes. **CAUTION: VALVE MAY BE DAMAGED BY TURNING IT IN TOO FAR.**
2. Open the needle valve (A) one and one half turns counter-clockwise.
3. Turn the idle valve (B) clockwise until it just closes.
4. Open idle valve (B) one half to three quarter turns.

#### FINAL ADJUSTMENT

1. Start the engine and run it at full speed.
2. See figure 18. Turn needle valve (A) clockwise until engine misses, (Lean mixture), then turn it out (counter-clockwise) past the smooth operating point, until the engine runs unevenly (Rich mixture). Now turn needle valve (A) to the mid-point between the rich and lean mixture so the engine runs smoothly.
3. Move the engine speed control lever to the slow position, and set the idle speed adjusting screw (C) so a fast idle is obtained (1200 RPM). Hold the throttle in this idle position and turn the idle valve (B) clockwise (lean) and counter-clockwise (rich) until the engine idles smoothly.
4. Reset the idle speed so the engine idles at 1200 RPM. Push the engine speed control lever forward to the fast position, the engine should accelerate without hesitation or sputtering. If the engine does not accelerate properly, readjust needle valve (A) to a slightly richer mixture.

# MAINTENANCE

Your tractor has been designed and manufactured to give you many years of dependable operation. In order for it to give you efficient, trouble free service over a long period of time the maintenance operations listed here must be performed on a regular basis. The optional hour meter provides an accurate method of determining when these services need to be performed.

A wide variety of attachments and accessories permit use of your tractor throughout the year. **BECAUSE YOUR TRACTOR IS A MULTI-SEASON TOOL, IT IS VERY IMPORTANT TO SERVICE THE ENGINE FOR THE SEASON IN WHICH IT WILL BE OPERATED.** Be sure to change to winter grade oil before making cold weather starts.

Whenever you are checking fluid levels in any area of the tractor, the readings will be much more accurate if the tractor is setting on level ground. We have provided the Scheduled Maintenance Chart on page 15 as a convenient means for you to know which services should be performed at various times. You should, of course, refer to the detailed explanation of how to perform each maintenance task until you are familiar enough with it to perform it correctly from memory.

Refer to your Briggs and Stratton operating and maintenance instructions for more specific detail on servicing the engine.

## ORDERING REPLACEMENT PARTS

Replacement parts required for performing maintenance services or repair work should be purchased from your dealer. When ordering parts be prepared to give him the tractor and engine identification numbers. If you have not already recorded these numbers on the inside front cover of this manual, we suggest that you do so now for convenient future reference.

## EVERY 5 HOURS OF OPERATION

**INSPECT THE TRACTOR AND ENGINE:** Make a general inspection of the tractor and engine looking for loose bolts, oil leaks, low tire pressures, etc. A few minutes spent correcting a small problem could prevent a costly breakdown later.

**CHECK ENGINE CRANKCASE OIL LEVEL:** See figure 19. If the engine has been running, allow a minute or two for the oil to drain down into the crankcase before checking the oil level. Proceed as follows:

1. See figure 19. Turn the engine oil filler cap-dipstick (A) counter-clockwise and lift it out.
2. Wipe the oil from the dipstick with a clean cloth.
3. Replace the filler cap-dipstick in the filler pipe and turn the cap clockwise finger tight.
4. Remove the filler cap-dipstick and check the oil level on the dipstick.
5. If the oil is below the full line (B) shown in figure 19, add enough oil to bring the oil level up to the full mark. Use the same grade and weight of oil which is already in the

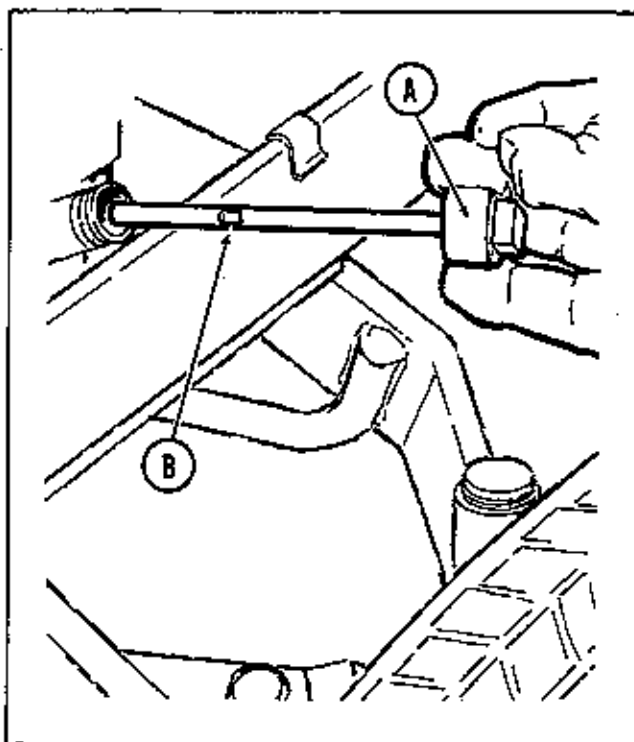

Figure 19. Checking the engine oil at right front of tractor.

engine. **DO NOT OVERFILL THE CRANKCASE.**

6. Replace the filler cap-dipstick (A) and tighten it securely.

## EVERY 25 HOURS OF OPERATION

**CLEAN ENGINE FINS AND SCREEN:** See figure 20. The blower screen (A) must be kept relatively free of chaff, grass, etc., which would restrict the flow of cooling

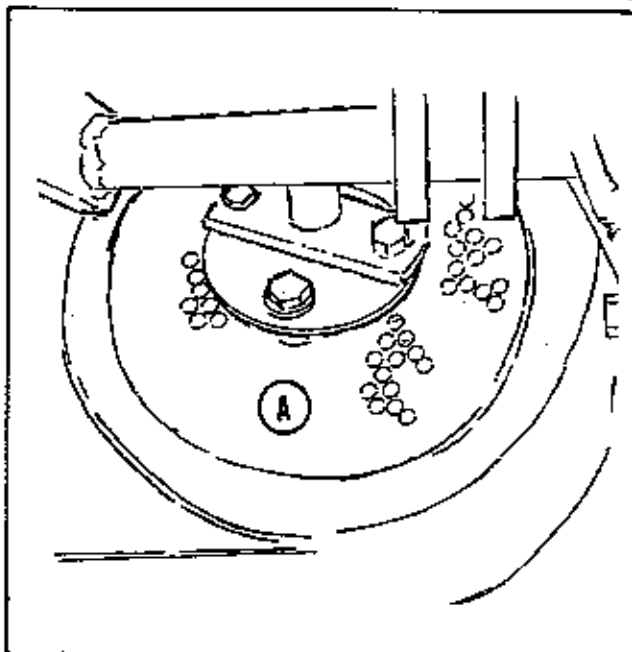

Figure 20. Engine blower screen located at rear of engine as seen from beneath tractor.

air to the engine. Material which collects can normally be removed with a brush after the engine is shut off. The screen may need to be cleaned more often when mowing dry grass.

See figure 22. All grass and chaff should be removed from the engine fins (A). **CAUTION: THE ENGINE FINS ARE VERY HOT AFTER THE ENGINE HAS BEEN OPERATED. DO NOT TOUCH THEM UNTIL THE ENGINE HAS BEEN ALLOWED TO COOL. NEVER SPRAY WATER ON A HOT ENGINE.**

**CHANGE ENGINE OIL:** Every 25 hours or more often under dusty operating conditions, change the engine oil, using an oil with designation of SC or SD or MS.

**SUMMER**  
(Above 40°F.)  
Use SAE 30

If not available,  
Use SAE 10W-30  
or  
SAE 10W-40

**WINTER**  
(Under 40°F.)  
Use SAE 5W-20 or  
SAE 5W-30

If not available,  
Use SAE 10W or  
SAE 10W-30

(Below 0°F)  
Use SAE 10W or  
SAE 10W-30

Diluted 10% with Kerosene

1. Operate the engine at least 10 minutes or until it is warm so the oil will drain freely.
2. See figure 21. Remove the drain plug (A) from the bottom of the engine base and allow the oil to drain.
3. After the oil has completely drained from the engine replace the drain plug and tighten it securely.
4. See figure 19. Remove the filler cap-dipstick (A) and pour 2 quarts of oil into the engine through the oil filler pipe, being careful not to allow any dirt or foreign material to contaminate the oil.
5. Check the oil level. It should show up to the full mark (B) on the dipstick.

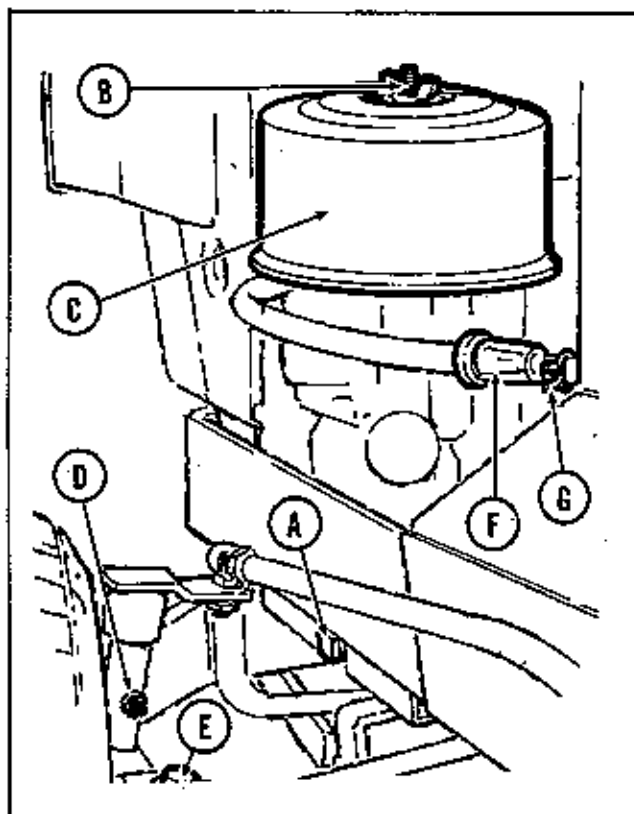

Figure 21. Left front of tractor.

6. Replace the oil filler cap-dipstick, start the engine and check for leaks.

**CLEAN ENGINE AIR FILTER:** The foam pre-cleaner should be removed and cleaned at 3 month intervals or every 25 hours of operation, whichever occurs first.

1. See figure 21. Remove the wing nut (B) and cover (C) from the air cleaner unit.
2. See figures 22 and 23. Remove the foam pre-cleaner (B) and wash it in liquid detergent and water and squeeze dry.
3. Oil the pre-cleaner with one ounce of engine oil, and

Service Required	Page	After each cycle of indicated hours			
		5	25	100	
Inspect the tractor and engine	14	●			
Check engine crankcase oil level	14	●			
Clean engine fins and screen*	14		●		
Change engine oil* (First change 5 hours)	15		●		
Clean engine air filter*	15		●		
Lubricate grease fittings*	16		●		
Lubricate pivot points*	16		●		
Check tire pressure	17		●		
Check transmission oil level	17		●		
Check bevel gearbox oil level	17		●		
Check battery water level*	18		●		
Clean or replace air filter element*	18			●	
Replace fuel filter*	18			●	
Repack front wheel bearings	18			●	
Repack planetary assembly	19			●	
Clean and reset spark plug	19			●	
Clean battery cables and connections	19			●	

\*More often under dusty and/or hot weather operating conditions.

See your Briggs and Stratton instructions for more complete information on servicing the engine.

Scheduled Maintenance Chart.

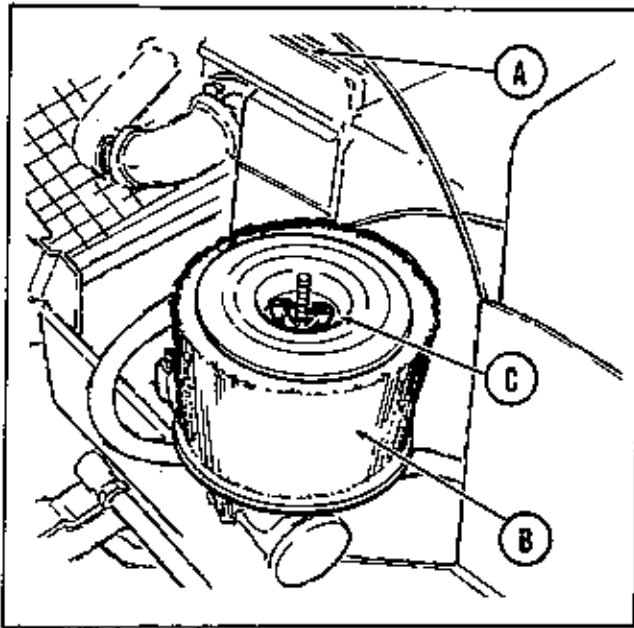

Figure 22. Air cleaner with cover removed on left side of engine.

squeeze it to distribute the oil evenly.

4. Install the foam precleaner as shown in figures 22 and 23.
5. See figure 21. Replace the air cleaner cover (C) and fasten it securely with wing nut (B).

**LUBRICATE GREASE FITTINGS:** Your tractor has 7 grease fittings which should be lubricated every 25 hours with multi-purpose lithium base gun grease. Wipe the fitting clean and lubricate each one with five shots of grease, or until the grease is seen being forced from the bearing. When operating under extremely wet or dusty conditions, lubricate more often. The grease fittings are located as follows:

LOCATION	ILLUSTRATION
Left Spindle	Figure 21, Item D
Right Spindle	Figure 24, Item A
Clutch-brake Pedal	Figure 24, Item B
Steering Bracket	Figure 25, Item A
Right Axle Hub	Figure 26, Item A
Right Axle	Figure 27, Item A

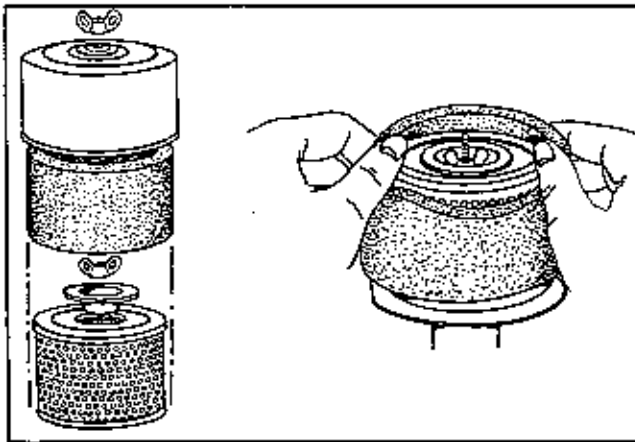

Figure 23. Air cleaner assembly disassembled.

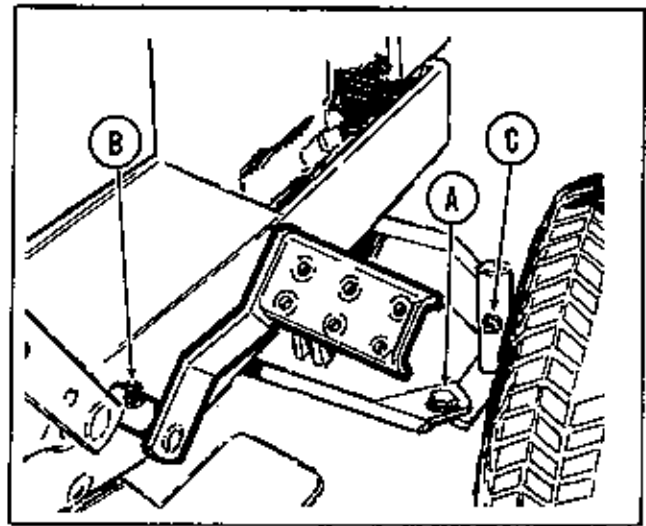

Figure 24. Right front corner of tractor.

**LUBRICATE PIVOT POINTS:** Every 25 hours a film of grease should be placed at the end of the neutral start safety switch, on the steering gear and on the shuttle drive brake detent to provide smoother operation and help reduce wear. They are located as follows:

LOCATION	ILLUSTRATION
Neutral Safety Start Switch	Figure 15, Item C
Steering Gear	Figure 25, Item B
Shuttle Drive Brake Detent	Figure 9, Items C & D

A few drops of engine oil placed on the tractor pivot points will help reduce wear and provide smoother operation of the tractor and its controls. Every 25 hours or more often under wet or dusty operating conditions, place a few drops of SAE 30 engine oil on the pivot points, being careful not to get oil on belts or pulleys as it may cause them to slip. Pivot points are located as follows:

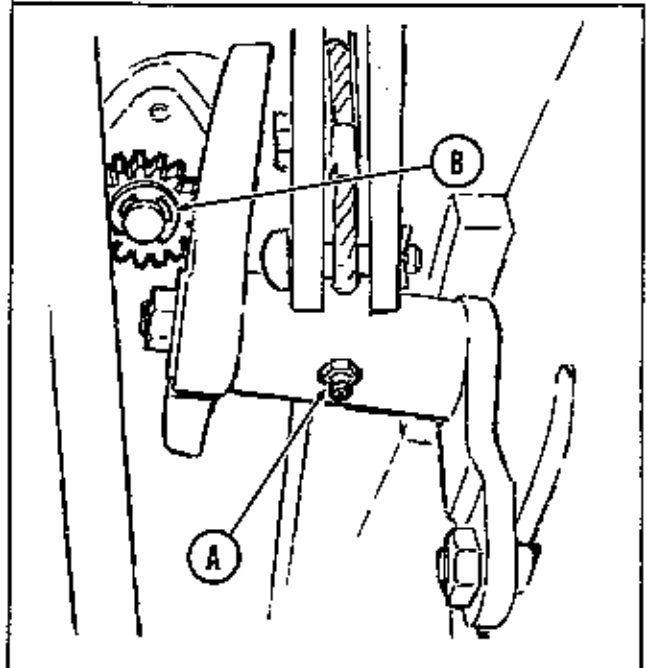

Figure 25. Steering gear as seen from beneath tractor.



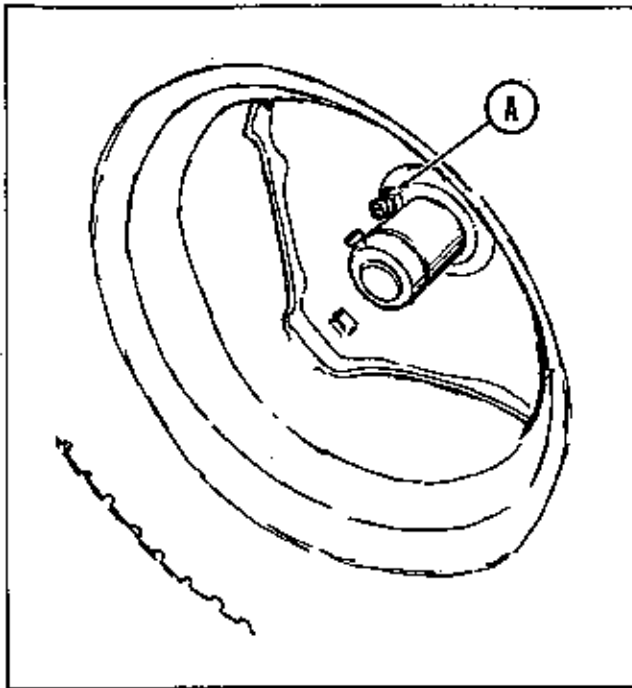

Figure 26. Grease zerk located inside right wheel hub.

LOCATION	ILLUSTRATION
Left Tie Rod End	Figure 21, Item E
Right Tie Rod End	Figure 24, Item C
Front Axle Pivot	Figure 28, Item A
Power Take Off Pivot	Figure 29, Item A

**CHECK TIRE PRESSURE:** Tires will last longer and perform better if they are kept properly inflated. They should be inflated as follows. Front tires 12 to 15 PSI. Rear tires 6 - 8 PSI.

**CHECK TRANSMISSION OIL LEVEL:** See figure 30. Remove pipe plug (A) to check the oil level in the axle housing. Oil should be level with the bottom of the threads. If it is not, add SAE 90 weight transmission oil. Replace the plug and tighten it securely.

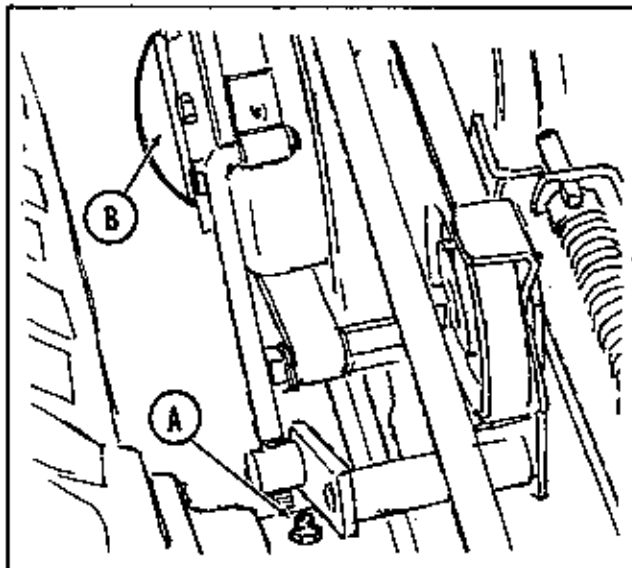

Figure 27. Grease zerk on right rear axle.

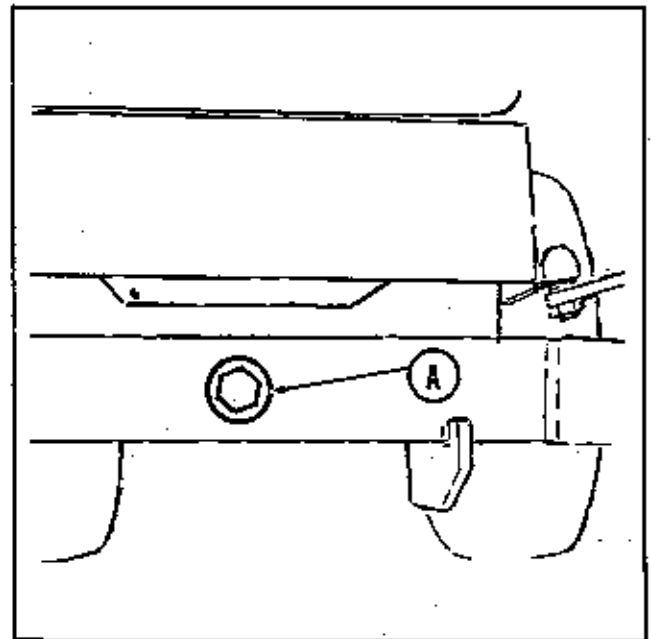

Figure 28. Front of tractor showing axle pivot.

If it should be necessary to drain the axle housing, the drain plug is located at (B). Always tighten it securely when replacing to prevent oil leakage.

**CHECK BEVEL GEAR BOX OIL LEVEL:** See figure 31. The bevel gear box fill plug is located at (A). The gear box is properly filled when SAE 90 weight transmission oil is added until it touches the end of the fill plug dipstick assembly. Do not screw plug into housing when measuring for oil level. Drain bevel gear housing by removing drain plug (B). To prevent oil leakage, securely tighten both fill and drain plugs. The fill plug assembly is vented.

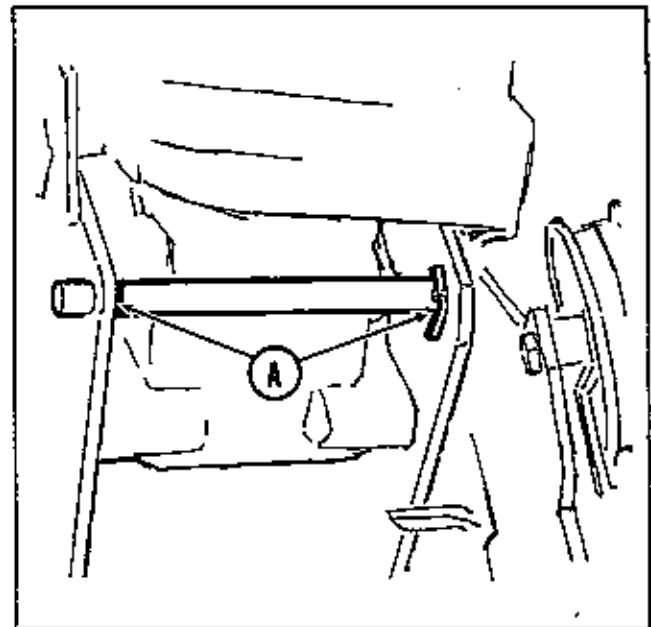

Figure 29. Power take off idler pulley, pivot points as seen from beneath tractor.

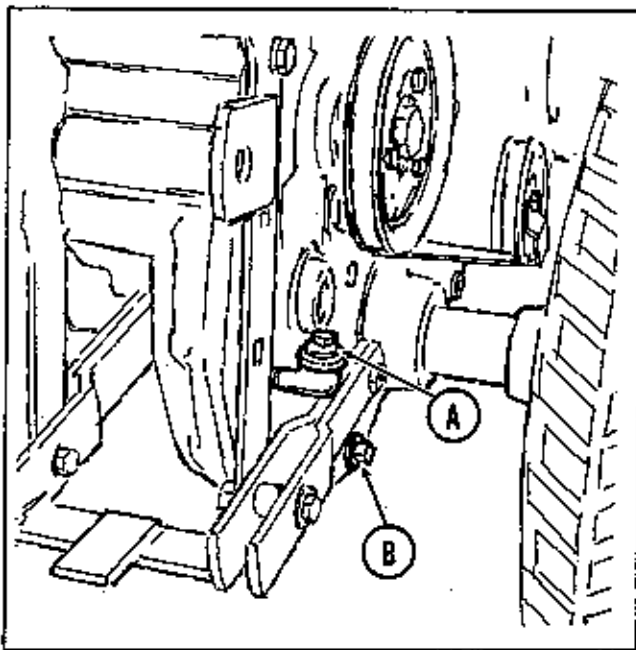

Figure 30. Rear of tractor showing axle drive housing.

**CHECK BATTERY WATER LEVEL:** See figure 32. Every 25 hours, or more often when operating the tractor in temperatures above 72°F, remove the 6 battery caps (A) and check the water level in each cell. When the battery is in use, water evaporates from it. Never allow the water level in the battery to get below the top of the plates. Fill the battery to the marking ring with distilled water as shown in figure 32. If distilled water is not available, clean tap water may be used.

### EVERY 100 HOURS OR ONCE A YEAR

#### CLEAN OR REPLACE AIR FILTER ELEMENT:

The engine air cleaner is made up of two types of filters. The foam filter (Figure 22, Item B) and a dry filtering element. The foam element should be cleaned and oiled every 25 hours as explained under the Every-25 Hour Maintenance

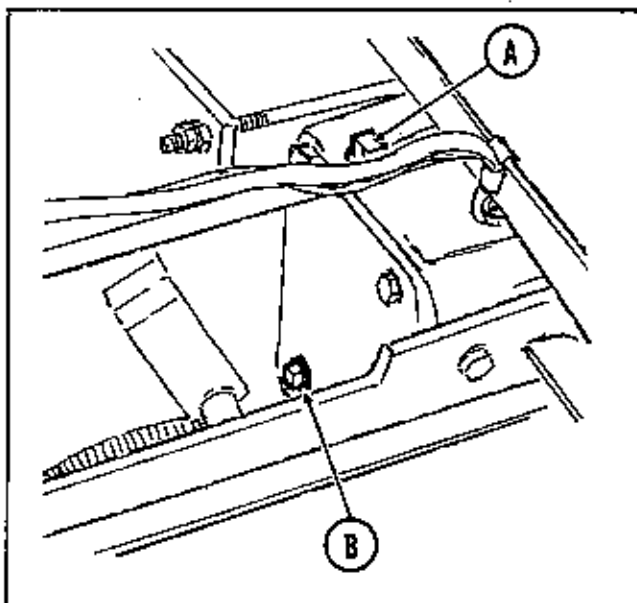

Figure 31. Bevel gear housing located under seat deck.

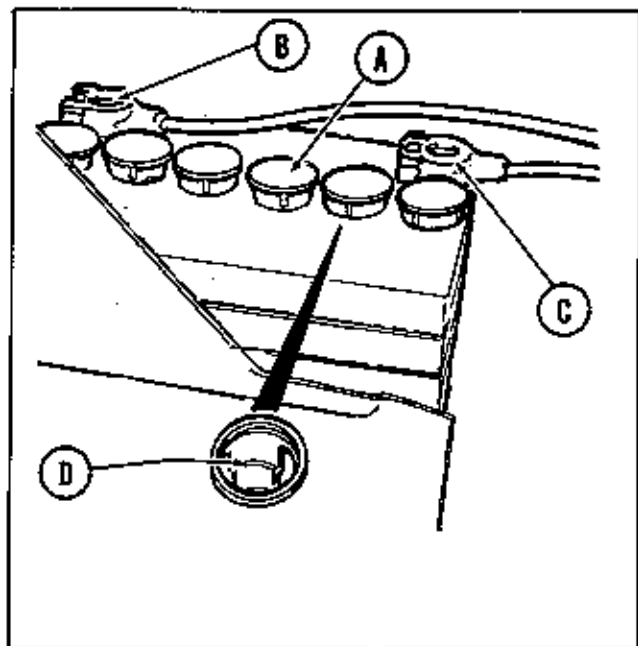

Figure 32. Tractor battery visible when hood is raised.

Services. Once a year or every 100 hours, whichever occurs first, the paper element should be removed and cleaned or replaced. Proceed as follows:

1. See figure 21. Remove wing nut (B) and cover (C) from the air cleaner.
2. See figures 22 & 23. Remove the foam element (B) and clean and oil it as described in the Every 25 Hour Maintenance Service.
3. Remove wing nut (C) and remove the paper element from the air cleaner.
4. Clean the element by tapping it gently on a flat surface. If it is very dirty, replace the element or wash it in detergent, and water rinse until water remains clear. The element must be dried thoroughly before using.
5. See figures 22 & 23. Replace the paper element and wing nut (C) and tighten it securely.
6. Install the foam element (B) over the paper element as shown in figure 22.
7. See figure 21. Replace cover (C) and wing nut (B) and tighten securely.

**REPLACE FUEL FILTER:** See figure 21. Every 100 hours or more often under dirty field conditions, the fuel filter (F) should be replaced. **CAUTION: DO NOT REMOVE THE FUEL FILTER WHEN THE ENGINE IS HOT, AS SPILLED GASOLINE MAY IGNITE. USE CARE WHEN REMOVING AND INSTALLING CLAMPS (G), NOT TO SPREAD THEM ANY MORE THAN NECESSARY AS THEY MAY TAKE A SET AND NOT HOLD THE HOSE TO THE FILTER PROPERLY.**

In extremely dirty fuel conditions, the fuel filter may become filled with dirt and restrict fuel flow. The filter can be washed in solvent and blown out with compressed air and used.

**REPACK FRONT WHEEL BEARINGS:** Every 100 hours of operation or once a year, the front wheel bearings should be removed and repacked with grease. Proceed as follows:

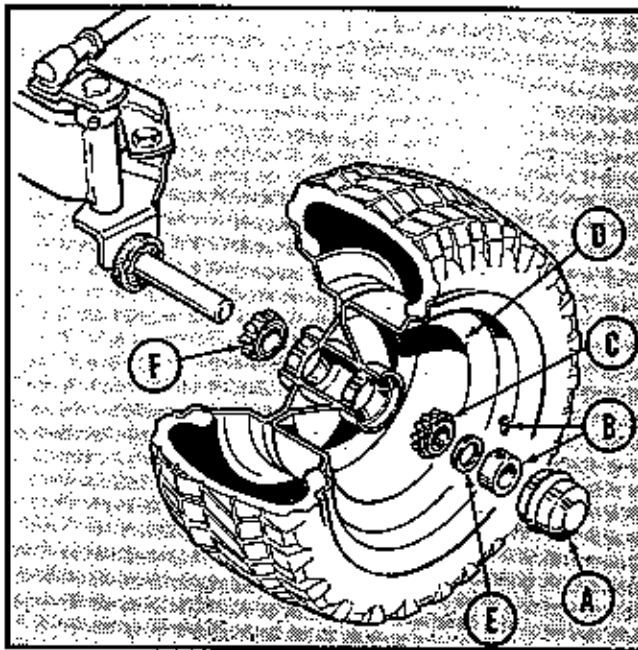

Figure 33. Left front soindle and axle assembly.

1. Block or jack the front of the tractor so the wheel you are to work on is not supporting the tractor.
2. See figure 33. Remove the grease cup (A) by prying off with a screwdriver or claw hammer.
3. Use an Allen wrench to loosen the set screw in collar (B).
4. Remove the set collar (B), spacer (E), outer bearing (C), wheel (D), and inner bearing (F). It is best to keep the two bearings separate so you can put them back in their original place. Wash the bearing shaft, bearings, and wheel housing with a suitable solvent and wipe dry. Inspect the seal of the inner wheel. Replace it if it is damaged. **NOTE: IT IS EXTREMELY IMPORTANT THAT THE BEARINGS AND GREASE THAT IS PACKED IN THEM BE KEPT CLEAN.**
6. Using the palm of your hand, force a good quality wheel bearing grease into the bearings. Place a coating of grease on the seal where it turns in the hub.
7. Replace the inner bearing and slide the wheel on the axle.
8. Replace the outer bearing, spacer, and set collar. Spin the wheel slowly and press in on the set collar to seat the bearing. Be sure the seal on the inside of the wheel is properly seated. Hold in on the set collar and tighten the Allen

### ACCESSORIES

There are many optional accessories available for your tractor through your dealer. They will make your tractor perform better, or easier to operate when using various attachments. For recommended accessories to use, when your tractor is to be operated with an attachment, see the Operation chart on page 7.

### ATTACHMENTS

To make your tractor most useful to you, we supply a complete line of attachments for it. They are available through your dealer. Contact him if you wish to purchase any of the following.

- 42" & 48" ROTARY MOWERS
- 46" SICKLE BAR MOWER

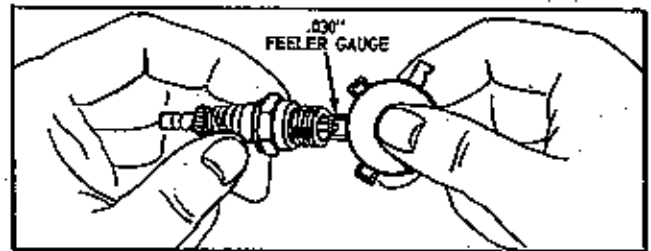

Figure 34. Setting spark plug gap.

screw securely.

9. Replace the grease cup.

**REPACK PLANETARY ASSEMBLY:** Every 100 hours of operation or once a year, the planetary assembly should be repacked with 2 lithium grease.

1. See figure 27. Remove cap (B) by prying off with a screwdriver.
2. Use caution in repacking the planetary assembly. It is extremely important that the grease being used is kept clean.
3. Replace the cap (B).

### CLEAN AND REPLACE SPARK PLUG:

See figure 34. Every 100 hours the spark plug should be removed, cleaned, and the gap reset at .030". When the spark plug is worn out, replace it with AC GC 46, Autolight A 71 or Champion J-8. **CAUTION: BLAST CLEANING OF SPARK PLUGS IN MACHINES THAT USE ABRASIVE GRIT IS NOT RECOMMENDED. SPARK PLUGS SHOULD BE CLEANED BY SCRAPING OR WIRE BRUSHING, AND WASHING WITH A COMMERCIAL SOLVENT.**

### CLEAN BATTERY CABLES:

See figures 32. Every 100 hours or once a year the battery cables (B) and (C) should be removed and cleaned. **CAUTION: ALWAYS REMOVE THE NEGATIVE GROUND CABLE (C) FIRST AND REPLACE IT LAST.** Clean the battery with soap and water to remove all dirt, oil, and corrosion from the battery surface. Do not allow foreign material or cleaning solution to get inside the battery. Clean the terminals and battery clamps with a wire brush. Replace and tighten securely. After tightening coat the terminals and clamps liberally with a coat of grease or vaseline to inhibit corrosion.

### VACUUM COLLECTOR

#### CART COVER

#### ROVING NOZZLE FOR VACUUM COLLECTORS

CART - DUMP 1000 POUND CAPACITY

CART - DUMP 400 POUND CAPACITY

38" LAWN REVITALIZER (Thatcher, aerator)

36" & 42" ROTARY SNOW THROWERS

46" SNOW PLOW AND DOZER BLADE

42" SNOW PLOW AND DOZER BLADE

SNOW CAB

36" ROTARY TILLER & 10" TINE EXT.

10" PLOW

CULTIVATOR

SPRING TOOTH HARROW

42" GRADER BLADE

# ENGINE AND DRIVE SHAFT

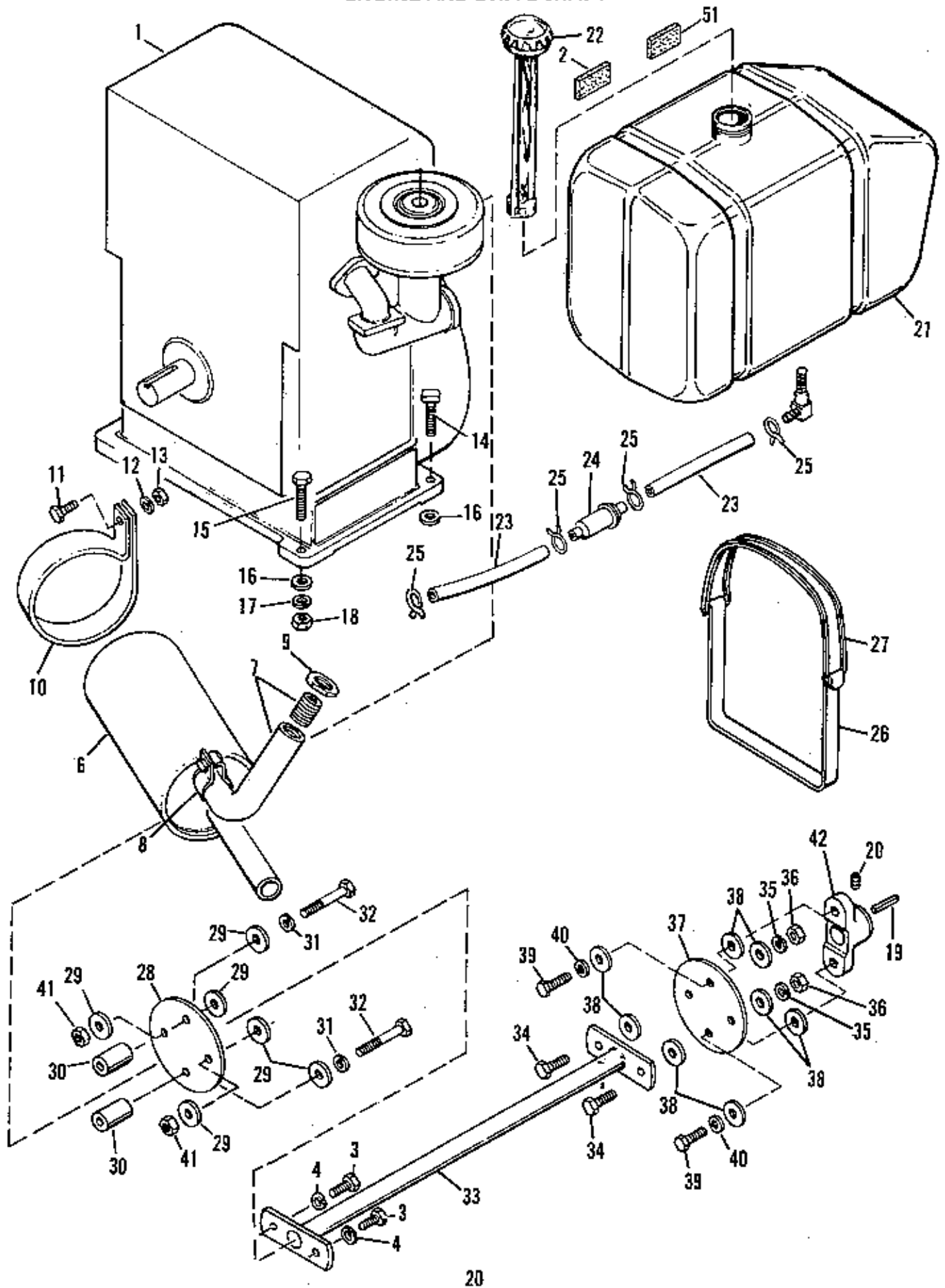

## ENGINE AND DRIVE SHAFT

Ref. No.	Part No.	Qty.	Description
1	—	1	ENGINE
2	173335	1	PAD, Fuel Tank
3	172677	2	CAPSCREW, Hex, 3/8"-16 -16 x 1-1/8" lg.
4	916965	2	WASHER, Plain, 3/8"
5	106582	1	GASKET, Felt
6	170456	1	MUFFLER, Exhaust
7	172195	1	ELBOW & PIPE ASSEMBLY
8	172061	1	CLAMP, Muffler
9	154378	1	NUT, Lock
10	171880	1	STRAP, Muffler
11	919318	1	CAPSCREW, Hex, 5/16" -18 x 5/8" lg.
12	917372	1	LOCKWASHER, 5/16"
13	917372	1	NUT, Hex, Full, 5/16"-18
14	172455	1	CAPSCREW, Rec. Hd, 3/8"-16 x 1-5/16" lg.
15	919360	3	CAPSCREW, Hex, 3/8" -16 x 1-1/2" lg.
16	917378	4	WASHER, Plain, 3/8"
17	917965	4	LOCKWASHER, 3/8"
18	916950	4	NUT, Hex, Full, 3/8"-16
19	157427	1	KEY
20	175049	1	SCREW, Set, 3/8"-24 x 3/8 lg.
21	171115	1	TANK, Fuel
22	171252	1	CAP, Fuel Tank
23	173204	2	HOSE, Fuel
24	173206	1	FILTER, Fuel
25	154372	4	CLAMP, Hose
26	171330	2	STRAP, Tank
27	172744	2	STRAP, Fuel Tank
28	173026	1	COUPLING
29	157424	8	WASHER, Special
30	8161056	2	BEARING, Pivot Block
31	916965	2	LOCKWASHER, 3/8"
32	922130	2	CAPSCREW, Hex, 3/8"-16 x 2-1/4" lg.
33	172328	1	SHAFT ASSEMBLY, Drive
34	172677	2	CAPSCREW, Hex, 3/8"-16 x 1-1/8" lg.
35	720002	2	LOCKWASHER, 3/8"
36	916965	2	NUT, Flex, Full, 3/8"-16
37	173026	1	COUPLING
38	157424	8	WASHER, Special
39	172677	2	CAPSCREW, Hex, 3/8"-16 x 1-1/8" lg.
40	916965	2	LOCKWASHER, 3/8"
41	916950	2	NUT, Hex, Full, 3/8"-16
42	172204	1	FLANGE, Drive Shaft

# FRAME, HOOD, GRILL & INSTRUMENT PANEL

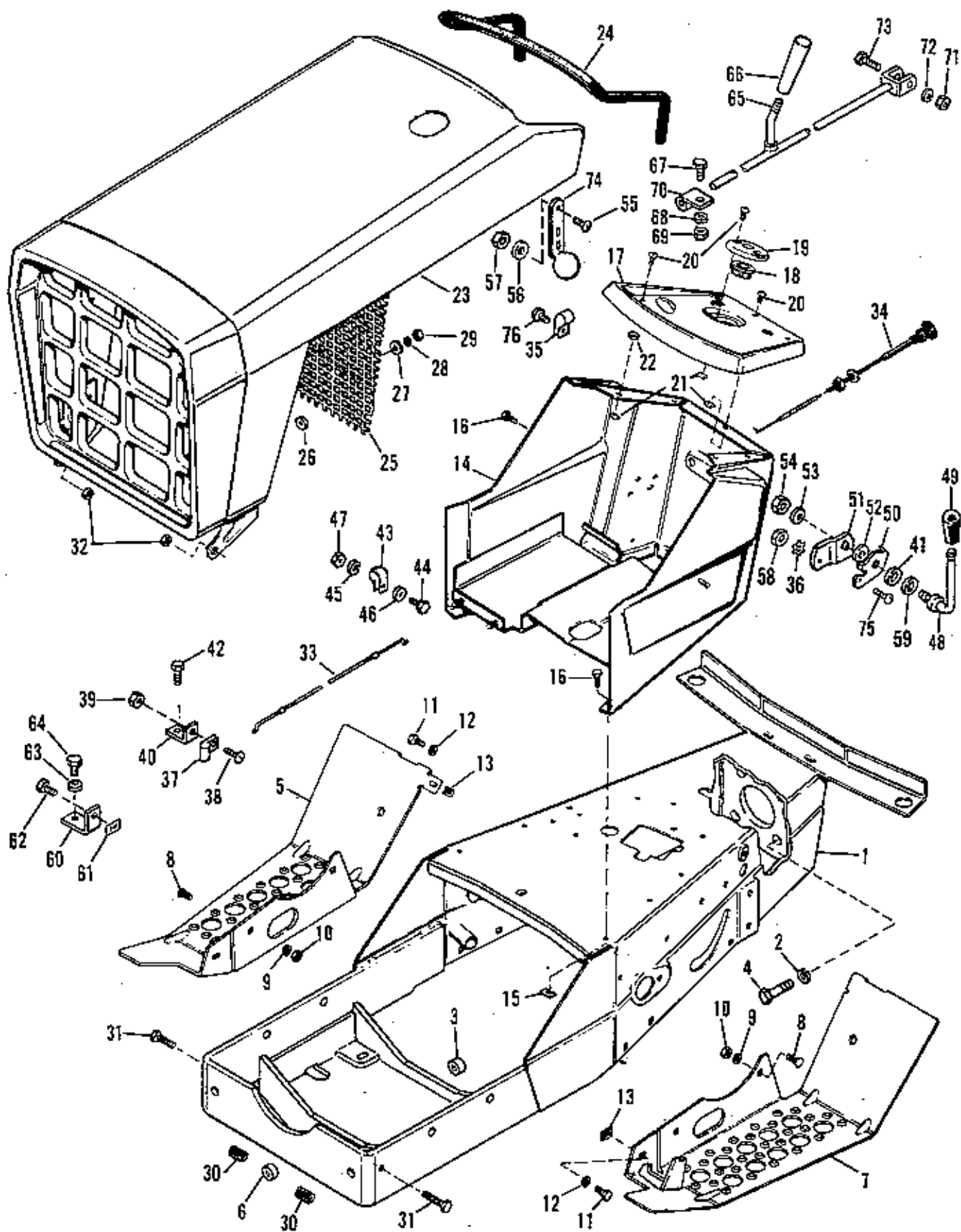

**FRAME, HOOD, GRILL & INSTRUMENT PANEL**

Ref. No.	Part No.	Qty.	Description	Ref. No.	Part No.	Qty.	Description
1	1650294	1	FRAME ASSEMBLY	39	917415	1	NUT, Hex, Full, # 10-32
2	918199	4	LOCKWASHER, 7/16"	40	157315	1	BRACKET, Throttle
3	154289	1	BUSHING	41	156116	1	WASHER
4	916608	4	CAPSCREW, Hex, 7/16" -14 x 1-1/2" lg.	42	925391	1	SCREW, Self Tapping, 1/4"-20 x 5/8" lg.
5	171271	1	FOOT REST, R.H.	43	122186	1	CLAMP
6	174662	1	BUSHING	44	907727	1	CAPSCREW, Hex, 1/4"-20 x 5/8" lg.
7	176628	1	FOOT REST, L.H.	45	916964	1	LOCKWASHER, 1/4"
8	823346	6	BOLT, Carriage 5/16"-18 x 3/4" lg.	46	917377	1	WASHER, Plain, 1/4"
9	917356	6	LOCKWASHER, 5/16"	47	916622	1	NUT, Hex, Full, 1/4"-20
10	917372	6	NUT, Hex, Full, 5/16"-18	48	1651170	1	HANDLE, Clutch
11	917397	2	CAPSCREW, Hex, 5/16-18 x 3/4" lg.	49	172038	1	KNOB
12	917356	2	LOCKWASHER, 5/16"	50	171848	1	STOP, Throttle
13	920470	2	NUT, Tinnerman	51	158424	1	ATM, Throttle
14	1650420	1	DASH ASSEMBLY	52	159107	1	WASHER
15	928703	8	NUT, Tinnerman	53	930665	1	WASHER, Dish Type
16	930561	11	SCREW, Self Tapping # 14 x 3/4" lg.	54	923428	1	NUT, Hex, Full, Lock, 3/8"-16
17	165100	1	PANEL, Instrument	55	930531	2	SCREW, Phillips Hd. # 10-32 x 1/2" lg.
18	157077	1	BUSHING, Steering	56	171804	2	WASHER
19	172008	1	PLATE, Steering	57	930627	2	NUT, Center Lock, # 10-32
20	926025	6	SCREW, Phillips, 1/4"-20 x 1/2" lg.	58	917415	1	NUT, Hex, Full, # 10-32
21	917867	6	NUT, Tinnerman	59	101025	1	WASHER
22	916955	4	WASHER, Plain, 3/16"	60	158811	1	BRACKET, Pulley Guard
23	1651135	1	HOOD & GRILLE ASSEMBLY	61	917867	1	NUT, Tinnerman
24	172935	1	MOLDING, Hood	62	927340	1	CAPSCREW, Hex, 1/4"-20 x 3/4" lg.
25	1651162	1	SCREEN, Grille	63	916955	1	WASHER, Plain, 3/16"
26	171804	2	WASHER	64	930562	1	CAPSCREW, # 14 x 1-1/4" lg.
27	172742	2	WASHER	65	171559	1	ROD ASSEMBLY, Shifter
28	922711	4	LOCKWASHER, Shake Shakeproof # 10	66	164180	1	HANDLE
29	916621	4	NUT, Hex, Full, # 10-24	67	930570	1	CAPSCREW, Hex, 5/16" -18 x 1-1/2" lg.
30	8191047	2	SPRING	68	917356	1	LOCKWASHER, 5/16"
31	919360	2	CAPSCREW, Hex, 3/8"-16 x 1-1/2" lg.	69	917372	1	NUT, Hex, Full, 5/16-18
32	923428	2	NUT, Hex, Full, Lock, 3/8"-16	70	157020	1	GUIDE ASSEMBLY, Shift Rod
33	171355	1	CONTROL, Throttle	71	916622	1	NUT, Hex, Full, 1/4"-20
34	1650997	1	CONTROL, Choke	72	916964	1	LOCKWASHER, 1/4"
35	158475	1	CLIP, Bowden, Wire	73	921959	1	CAPSCREW, Hex, 1/4"-20 x 5/8" lg.
36	922711	1	LOCKWASHER, Shakeproof # 10	74	171600	2	STRAP, Hood
37	158475	1	CLIP, Bowden, Wire	75	917452	1	SCREW, Rd. Hd. # 10-32 x 1/2" lg.
38	922121	1	SCREW, Rd. Hd., # 10-30 x 3/8" lg.	76	923734	1	SCREW, Self Tapping

## BEVEL GEAR HOUSING

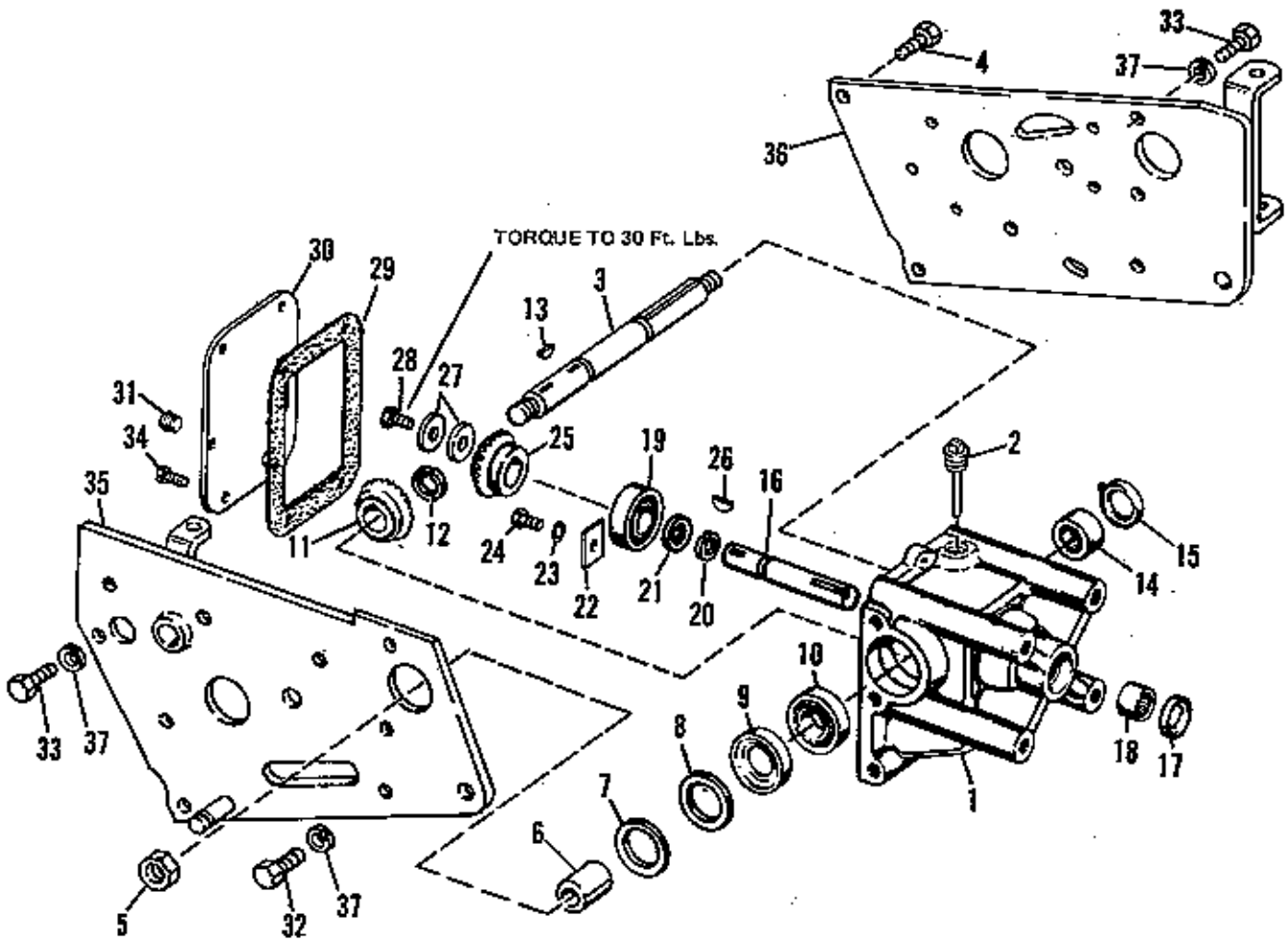

Ref. No.	Part No.	Qty.	Description
1	171797	1	HOUSING, Gear, Bevel
2	178105	1	PLUG ASSEMBLY
3	173966	1	SHAFT, Driven
4	820677	4	CAPSCREW, Hex, 7/16-14 x 1-1/4" lg.
5	922133	1	NUT, Hex, Jam, 3/4"-16
6	171792	1	SPACER
7	171790	5	SHIM (As Required)
8	171791	1	SHIM
9	171787	1	SEAL, Oil
10	172256	1	BEARING, Ball
11	171796	1	GEAR, Bevel, Driven
12	172206	1	RING, Retaining
13	725003	1	KEY
14	154279	1	BEARING, Needle
15	118117	1	SEAL, Oil
16	172750	1	SHAFT, Driven
17	118117	1	SEAL, Oil
18	154279	1	BEARING, Needle
19	172256	1	BEARING, Ball
20	172206	1	RING, Retaining
21	172753	1	WASHER

Ref. No.	Part No.	Qty.	Description
22	154040	1	PLATE, Clamp, Bearing
23	917356	1	LOCKWASHER, 5/16"
24	919318	1	CAPSCREW, Hex, 5/16-18 x 5/8" lg.
25	172752	1	GEAR, Bevel, Driven
26	905123	1	KEY
27	177649	2	WASHER
28	154281	1	CAPSCREW, Hex
29	154282	1	GASKET
30	178104	1	COVER
31	901652	1	PLUG, Pipe
32	920676	6	CAPSCREW, Hex, 7/16" -14 x 1" lg.
33	920677	4	CAPSCREW, Hex, 7/16" -14 x 1-1/4" lg.
34	930526	6	CAPSCREW, Hex, 1/4" -20 x 5/8" lg.
35	173859	1	PLATE ASSEMBLY, Side, R.H.
36	174829	1	PLATE ASSEMBLY, Side, L.H.
37	918199	10	LOCKWASHER, 7/16"



### SEAT AND FENDERS

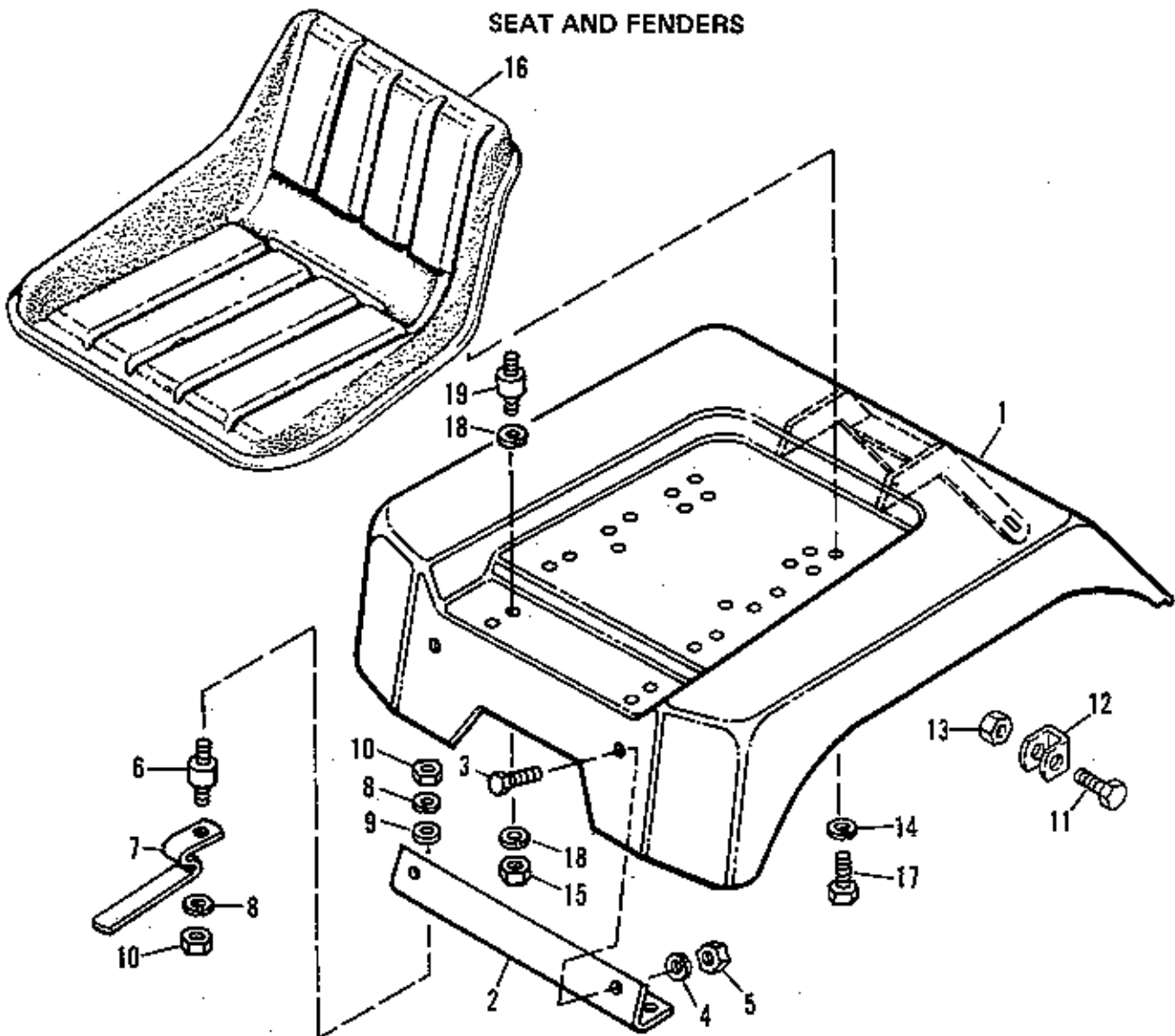

Ref. No.	Part No.	Qty.	Description
1	166111	1	DECK ASSEMBLY, Seat
2	164029	1	BRACKET, Frt. Seat Deck
3	919318	2	CAPSCREW, Hex, 5/16"-18 x 5/8" lg.
4	917356	2	LOCKWASHER, 5/16"
5	917372	2	NUT, Hex, Full, 5/16"-18
6	157094	2	CONNECTOR, Cushion, Frt.
7	1606823	2	CLIP, Seat Deck Latch
8	917356	4	LOCKWASHER, 5/16"
9	917377	2	WASHER, Plain, 1/4"
10	917372	4	NUT, Hex, Full, 5/16"-18
11	917400	2	CAPSCREW, Hex, 3/8"-16 x 1-1/4" lg.

Ref. No.	Part No.	Qty.	Description
12	1607870	1	STOP, Seat Deck
13	923428	2	NUT, Hex, Full, Lock, 3/8"-16
14	917356	2	LOCKWASHER, 5/16"
15	917372	2	NUT, Hex, Full, 5/16"-18
16	171153	1	CONTOUR SEAT ASSEMBLY
17	919318	2	CAPSCREW, Hex, 5/16-18 x 5/8" lg.
18	720001	4	LOCKWASHER, 5/16"
19	159085	2	CONNECTOR, Cushion
20	917372	2	NUT, Hex, Full, 5/16"-18

# POWER TAKE-OFF

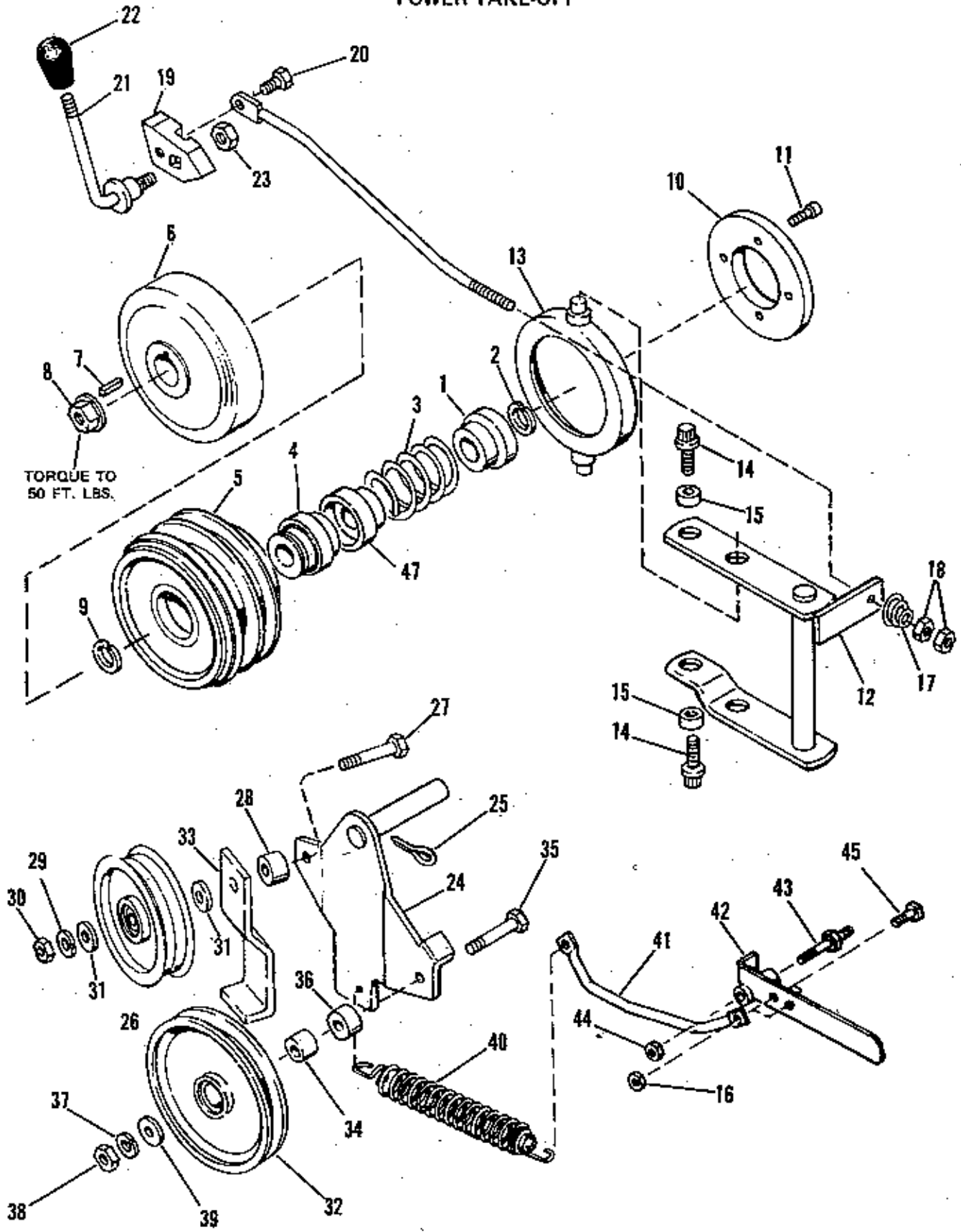

**POWER TAKE-OFF**

Ref. No.	Part No.	Qty.	Description
1	1650264	1	GUIDE, Spring
2	172206	1	RING, Retaining
3	171772	1	SPRING
4	1650254	1	BEARING ASSEMBLY
5	1650304	1	PULLEY
6	174862	1	CLUTCH PLATE ASSEMBLY
7	8061081	1	KEY
8	930644	1	NUT, Flange, Lock, 1/2"-13
9	172206	1	RING, Retaining
10	173957	1	DISK, Brake
11	920036	4	SCREW, Socket Hd, 1/4"-20 x 5/8" lg.
12	1650906	1	PIVOT ASSEMBLY
13	174013	1	SUPPORT, Brake Assembly
14	1651450	2	SCREW, Thread Forming
15	171371	2	BUSHING
16	173988	1	ROD, Control
17	175316	1	SPRING, Conical
18	917372	2	NUT, Hex, Full, 5/16"-18
19	173991	1	LEVER
20	174686	1	CAPSCREW, Special, 5/16"-16 x 7/8" lg.
21	174664	1	HANDLE, Clutch pto
22	172038	1	KNOB
23	717510	1	NUT, Hex, Full, Lock, 3/8"-16

Ref. No.	Part No.	Qty.	Description
24	174455	1	PIVOT ARM ASSEMBLY
25	918469	1	PIN, Cotter, 3/16" x 1-1/2" lg.
26	105306	1	PULLEY
27	917402	1	CAPSCREW, 3/8"-16 x 2" lg.
28	157081	1	SPACER
29	916965	1	LOCKWASHER, 3/8"
30	916950	1	NUT, Hex, Full, 3/8"-16
31	917642	2	WASHER, Plain, 5/16"
32	173982	1	PULLEY, Idler
33	170289	1	STOP, Belt
34	170291	1	SPACER
35	917402	1	CAPSCREW, Hex, 3/8"-16 x 2" lg.
36	172329	1	SPACER
37	916965	1	LOCKWASHER, 3/8"
38	916950	1	NUT, Hex, Full, 3/8"-16
39	917642	1	WASHER, Plain, 5/16"
40	157262	1	SPRING, Tension
41	164047	1	ROD, Spring Tension
42	164155	1	HANDLE ASSEMBLY
43	157273	1	STUD
44	924058	1	NUT, Hex, Full, Lock, 7/16"-14
45	917397	1	CAPSCREW, Hex, 5/16"- 18 x 3/4" lg.
46	923362	1	NUT, Hex, Full, Lock, 5/16"-18
47	1650252	1	GUIDE, Spring

## FRONT LIGHT GROUP

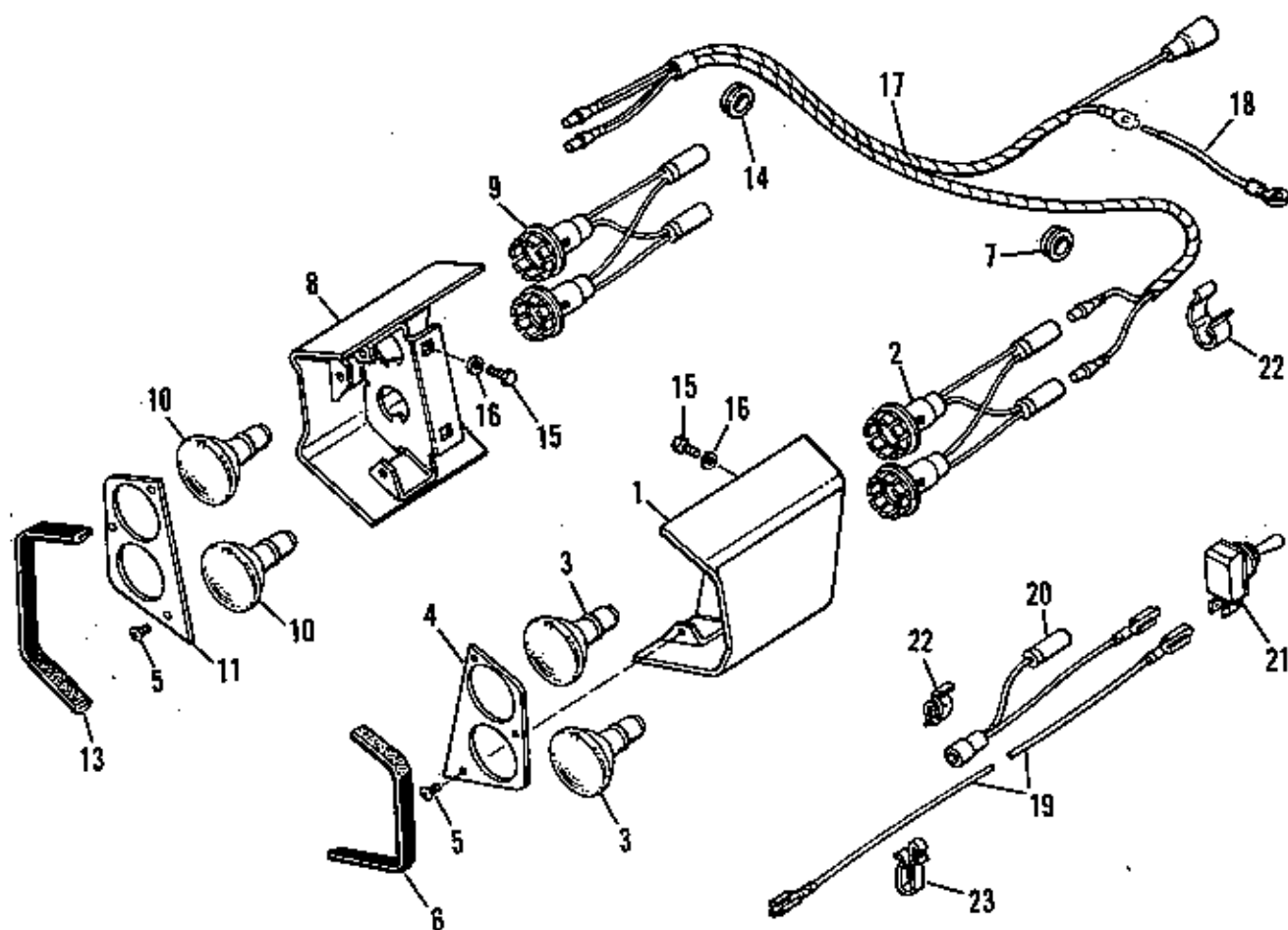

Ref. No.	Part No.	Qty.	Description
1	172286	1	SHROUD & PLATE ASSEMBLY L.H.
2	172290	1	LAMP SOCKET & WIRE ASSEMBLY
3	172048	2	HEADLIGHT
4	172243	1	PLATE, Front
5	928695	3	SCREW, Thread Forming, #12-24 x 1/2" lg.
6	172269	1	MOLDING
7	172176	1	GROMMET
8	172285	1	SHROUD & PLATE ASSEMBLY R.H.
9	172290	1	LAMP SOCKET & WIRE ASSEMBLY
10	172048	2	HEADLIGHT
11	172243	1	PLATE, Front

Ref. No.	Part No.	Qty.	Description
12	928695	3	SCREW, Thread Forming #12-24 x 1/2" lg.
13	172269	1	MOLDING
14	172176	1	GROMMET
15	916019	4	SCREW, Hex, 1/4"-20 x 3/4" lg.
16	916964	4	LOCKWASHER, 1/4"
17	172294	1	HARNES ASSEMBLY
18	1651821	1	WIRE, Headlight to Ground
19	172296	1	WIRE ASSEMBLY, Light Switch
20	1651147	1	WIRE ASSEMBLY
21	122184	1	SWITCH, Toggle
22	178436	2	CABLE Clip, Tinnerman
23	172434	1	CABLE Clip, Tinnerman

## REAR WHEELS AND AXLE

NOTE: REFERENCE NUMBERS 18 AND 27  
MUST BE REPLACED IN PAIRS

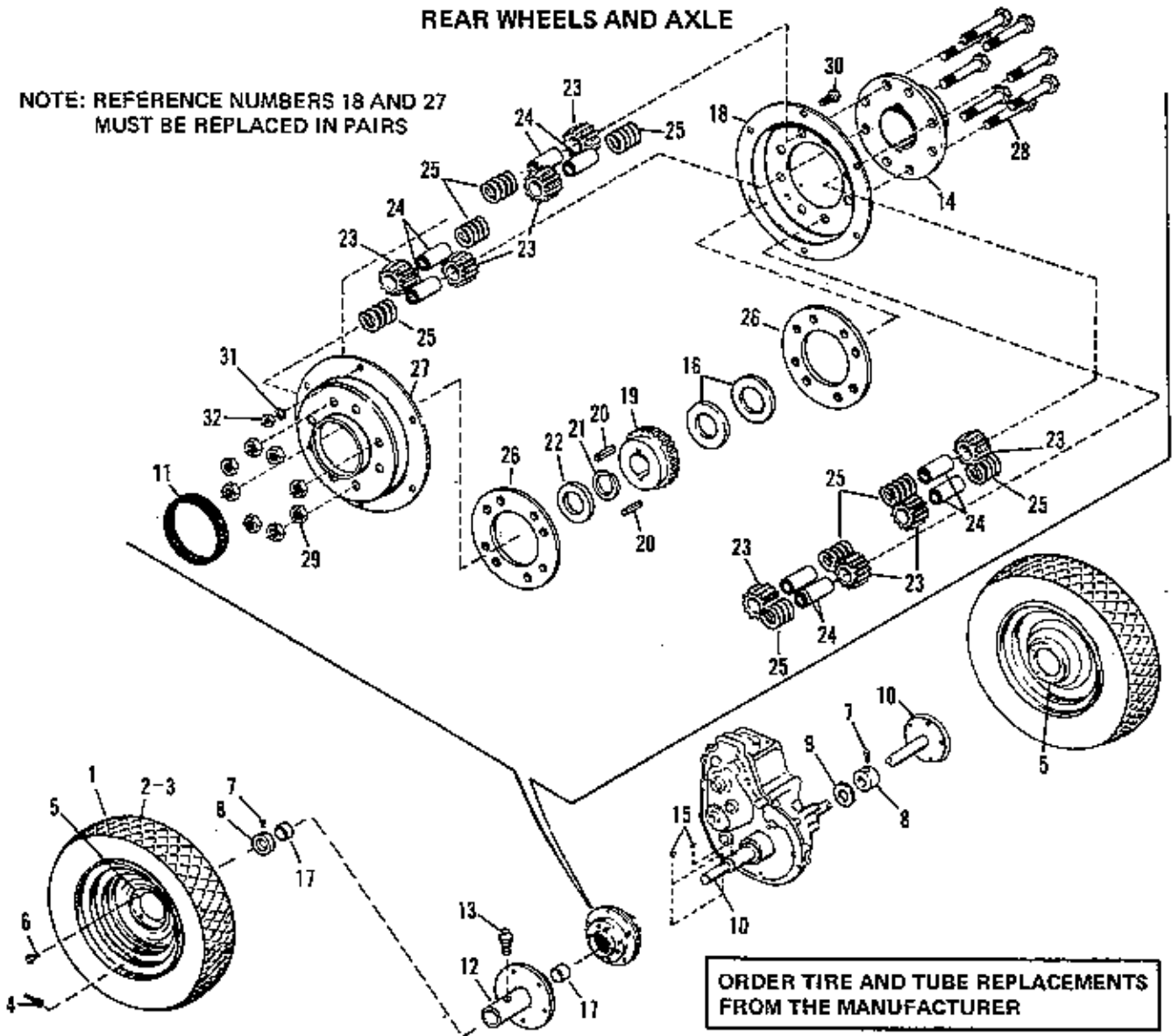

Ref. No.	Part No.	Qty.	Description
1	173432	2	WHEEL & TIRE ASSEMBLY
2	157637	2	TIRE
3	157638	2	TUBE
4	172353	2	STEM, Valve & Cap
5	173430	2	WHEEL, Drive
6	8261100	10	BOLT, Hub
7	928709	4	SCREW, Set, 5/16"-18 x 3/8" lg.
8	154065	2	COLLAR, Set
9	105050	1	WASHER
10	177900	1	REAR AXLE ASSEMBLY
11	121190	1	SEAL, Diff. Cover
12	176945	1	HUB ASSEMBLY
13	727004	1	FITTING, Grease
14	164217	1	CARRIER, Diff.
15	157120	2	KEY
16	171515	2	WASHER, Axle
17	153068	2	BEARING

Ref. No.	Part No.	Qty.	Description
18	171853	1	COVER, Diff.
19	177041	1	GEAR, Diff.
20	930671	2	KEY
21	154291	1	RING, Retaining
22	154277	1	WASHER, Axle
23	158579	8	PINION, Diff.
24	121083	8	SPINDLE, Pinion, Diff.
25	162085	8	SPRING
26	171517	2	RING, Spacer
27	171854	1	COVER, Diff.
28	921972	8	CAPSCREW, Hex, 3/8"-18 x 2-1/2" lg.
29	923428	8	NUT, Hex, Full, Lock, 3/8"-16
30	907727	6	CAPSCREW, Hex, 1/4"-20 x 5/8" lg.
31	916964	6	LOCKWASHER, 1/4"
32	916622	6	NUT, Hex, Full, 1/4"-20

# ELECTRICAL SYSTEM

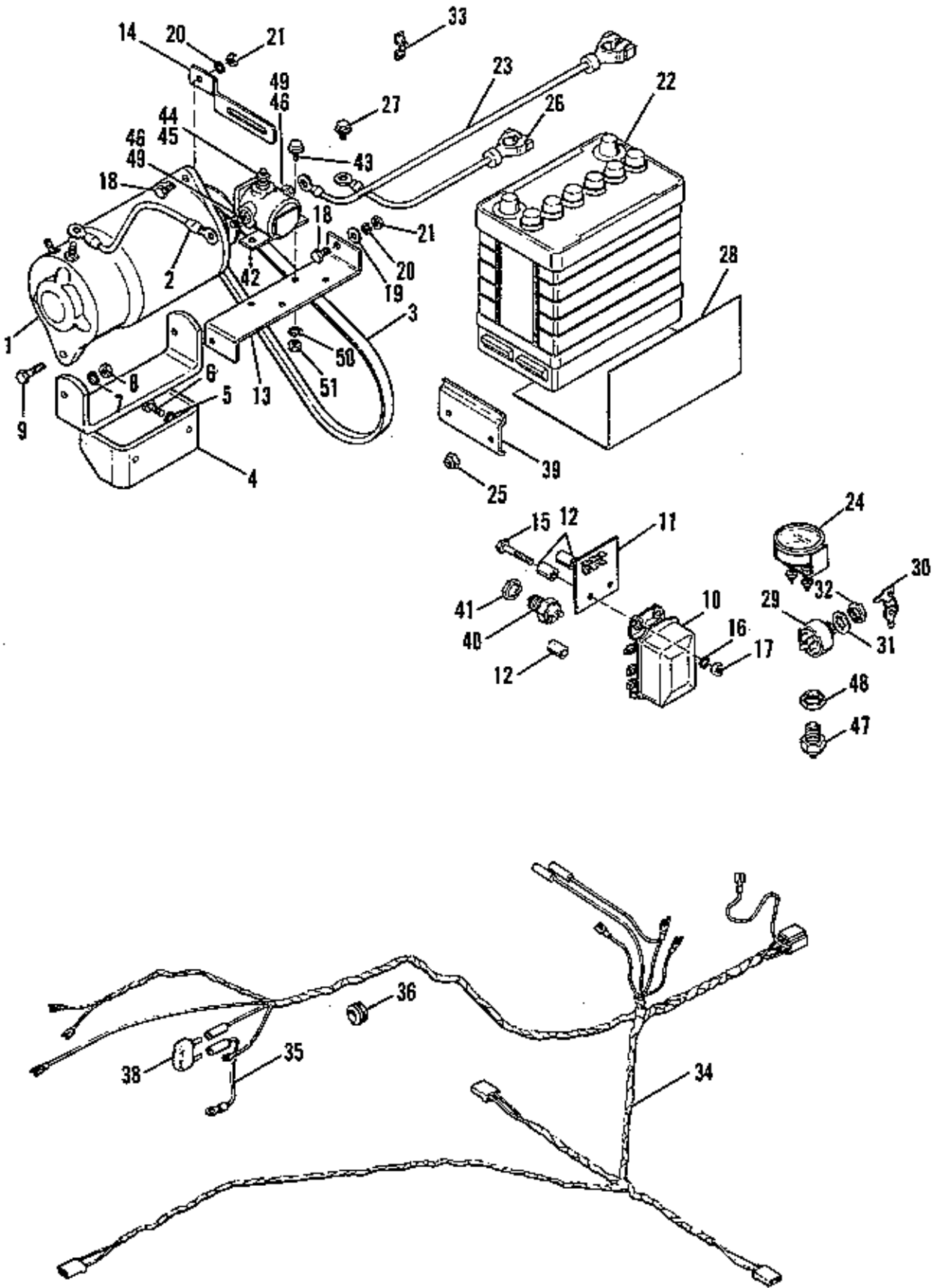

## ELECTRICAL SYSTEM

Ref. No.	Part No.	Qty.	Description
1	122236	1	MOTOR, Generator
2	122213	1	CABLE, Generator to Solenoid
3	157524	1	BELT, "V"
4	157654	1	SUPPORT ASSEMBLY
5	917356	2	LOCKWASHER, 5/16"
6	917397	2	CAPSCREW, Hex, 5/16-18 x 3/4" lg.
7	917356	2	LOCKWASHER, 5/16"
8	917372	2	NUT, Hex, Full, 5/16"-18
9	907729	2	CAPSCREW, Hex, 5/16"-18 x 1-1/4"
10	122193	1	REGULATOR, Voltage
11	1651128	1	BOARD, Terminal
12	106132	3	SPACER
13	176931	1	BRACKET
14	157102	1	ARM, Adjusting, Generator
15	919316	3	CAPSCREW, Hex, 1/4"-20 x 1-3/4" lg.
16	921880	3	LOCKWASHER, Shakeproof, 1/4"
17	916622	3	NUT, Hex, Full, 1/4"-20
18	921332	1	CAPSCREW, Hex, 5/16"-18 x 3/4" lg.
19	917642	1	WASHER, Plain 5/16"
20	917356	2	LOCKWASHER, 5/16"
21	917372	2	NUT, Hex, Full, 5/16"-18
22	172270	1	BATTERY
23	1651103	1	CABLE, Battery
24	1603189	1	AMMETER
25	924433	2	NUT, Elastic, Stop, 5/16"-18

Ref. No.	Part No.	Qty.	Description
26	171811	1	CABLE, Battery to Ground
27	925003	1	SCREW, Hex, Washer Hd. 1/4"-20 x 1/2" lg.
28	172119	1	INSULATION, Fuel Tank
29	178280	1	SWITCH, Ignition
30	122203	1	KEY & RING ASSEMBLY
31	918906	1	LOCKWASHER, Int. 5/8"
32	122234	1	NUT, Hex, Special
33	176912	2	CLIP, Wire
34	1651104	1	HARNESS ASSEMBLY
35	1651031	1	WIRE ASSEMBLY
36	172175	1	GROMMET
37	106786	1	CLAMP
38	172163	1	BREAKER, Circuit
39	171225	1	CLAMP, Battery
40	177522	1	SWITCH, Safety
41	930647	1	NUT, Pal, 9/16"-18
42	122216	1	SOLENOID
43	925003	2	SCREW, Hex, Washer Hd. 1/4"-20 x 1/2" lg.
44	917415	1	NUT, Hex, Full, #10-32
45	922711	1	LOCKWASHER, Shakeproof, #10-32
46	917372	2	NUT, Hex, Full, 5/16"-18
47	177522	1	SWITCH, Safety
48	930647	1	NUT, Pal
49	917356	2	LOCKWASHER, 5/16"
50	916964	2	LOCKWASHER, 1/4"
51	916622	2	NUT, Hex, Full, 1/4"-20

# BRAKE AND LEVER GROUP

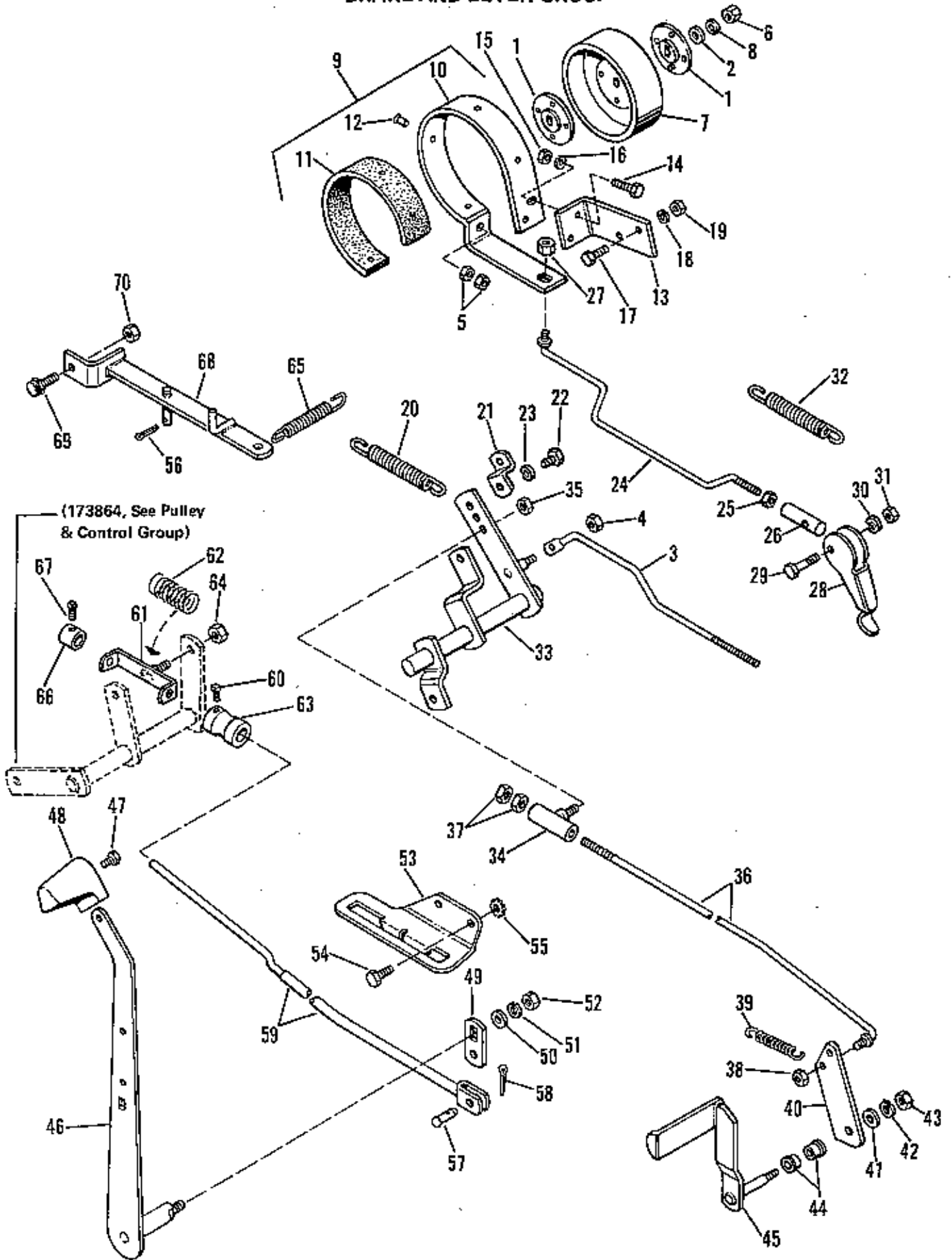



## BRAKE &amp; LEVER

Ref. No.	Part No.	Qty.	Description	Ref. No.	Part No.	Qty.	Description
1	158196	2	WASHER, Special	37	917372	2	NUT, Hex, Full, 5/16"-18
2	917378	1	WASHER, Plain	38	923362	1	NUT, Hex, Full, Lock, 5/16"-18
3	172722	1	ROD, Brake	39	159106	1	SPRING
4	923362	1	NUT, Hex, Full, Lock, 5/16"-18	40	157300	1	ARM, Pedal, Foot
5	916950	2	NUT, Hex, Full, 3/8"-16	41	917378	1	WASHER, Plain, 3/8"
6	918213	1	NUT, Hex, Full, 7/16"-14	42	720002	1	LOCKWASHER, 3/8"
7	157282	1	DRUM, Brake	43	916950	1	NUT, Hex, Full, 3/8"-16
8	918199	1	LOCKWASHER, 7/16"	44	108419	2	BUSHING
9	171497	1	BAND ASSEMBLY, Brake	45	171178	1	PEDAL ASSEMBLY, Foot
10	171482	1	BAND, Brake	46	171072	1	LEVER ASSEMBLY, Planetary
11	154133	1	LINING, Brake	47	715085	1	SCREW, Thread Forming, 1/4"-20 x 3/4" lg.
12	907166	4	RIVET, # 7 x 5/16" lg.	48	171185	1	KNOB
13	164113	1	BRACKET, Brake Band	49	164123	1	LINK
14	907731	2	CAPSCREW, Hex, 3/8"-16 x 1" lg.	50	917378	1	WASHER, Plain, 3/8"
15	916950	2	NUT, Hex, Full, 3/8"-16	51	916695	1	LOCKWASHER, 3/8"
16	916965	2	LOCKWASHER, 3/8"	52	916950	1	NUT, Hex, Full, 3/8"-16
17	916019	2	CAPSCREW, Hex, 1/4"- 20 x 3/4" lg.	53	174473	1	QUADRANT
18	916964	2	LOCKWASHER, 1/4"	54	172157	2	SCREW, Special
19	916622	2	NUT, Hex, Full, 1/4"-20	55	920426q	2	LOCKWASHER, Shake- proof, 5/16"
20	174896	1	SPRING	56	918447	1	PIN, Cotter, 3/32" x 3/4" lg.
21	174893	1	CLIP, Spring	57	153058	1	PIN
22	916432	1	CAPSCREW, Hex, 7/16"- 14 x 1-1/4" lg.	58	918447	1	PIN, Cotter, 3/32 x 3/4" lg.
23	918199	1	LOCKWASHER, 7/16"	59	173876	1	ROD ASSEMBLY
24	174708	1	ROD ASSEMBLY	60	928804	1	SCREW, Set, 1/4"-20 x 3/8" lg.
25	923422	1	NUT, Hex, Full, Lock, 5/16"-18	61	175335	1	GUIDE ASSEMBLY, Rod
26	171994	1	ROD, End	62	162065	1	SPRING
27	917372	1	NUT, Hex, Full, 5/16"-18	63	174855	1	DETENT, Brake
28	172108	1	LEVER, Brake, Parking	64	930628	1	NUT, Hex, Full, Lock, 3/8"-24
29	715062	1	CAPSCREW, Hex, 1/4"- 20 x 1-1/4" lg.	65	175290	1	SPRING
30	721702	1	LOCKWASHER, Double, 1/4"	66	105201	1	COLLAR, Set
31	923329	1	NUT, Hex, Full, Lock, 1/4"-20	67	928804	1	SCREW, Set, 1/4"-20 x 3/8" lg.
32	121037	1	SPRING	68	174852	1	LEVER ASSEMBLY; Brake
33	172724	1	LEVER ASSEMBLY, Pivot	69	174854	1	PAD ASSEMBLY, Brake
34	164094	1	GUIDE ASSEMBLY, Rod	70	920161	1	NUT, Hex, Jam, 5/16"-18
35	923362	1	NUT, Hex, Full, Lock, 5/16"-18				
36	174105	1	ROD ASSEMBLY, Brake & Clutch				

# PULLEY AND CONTROL GROUP

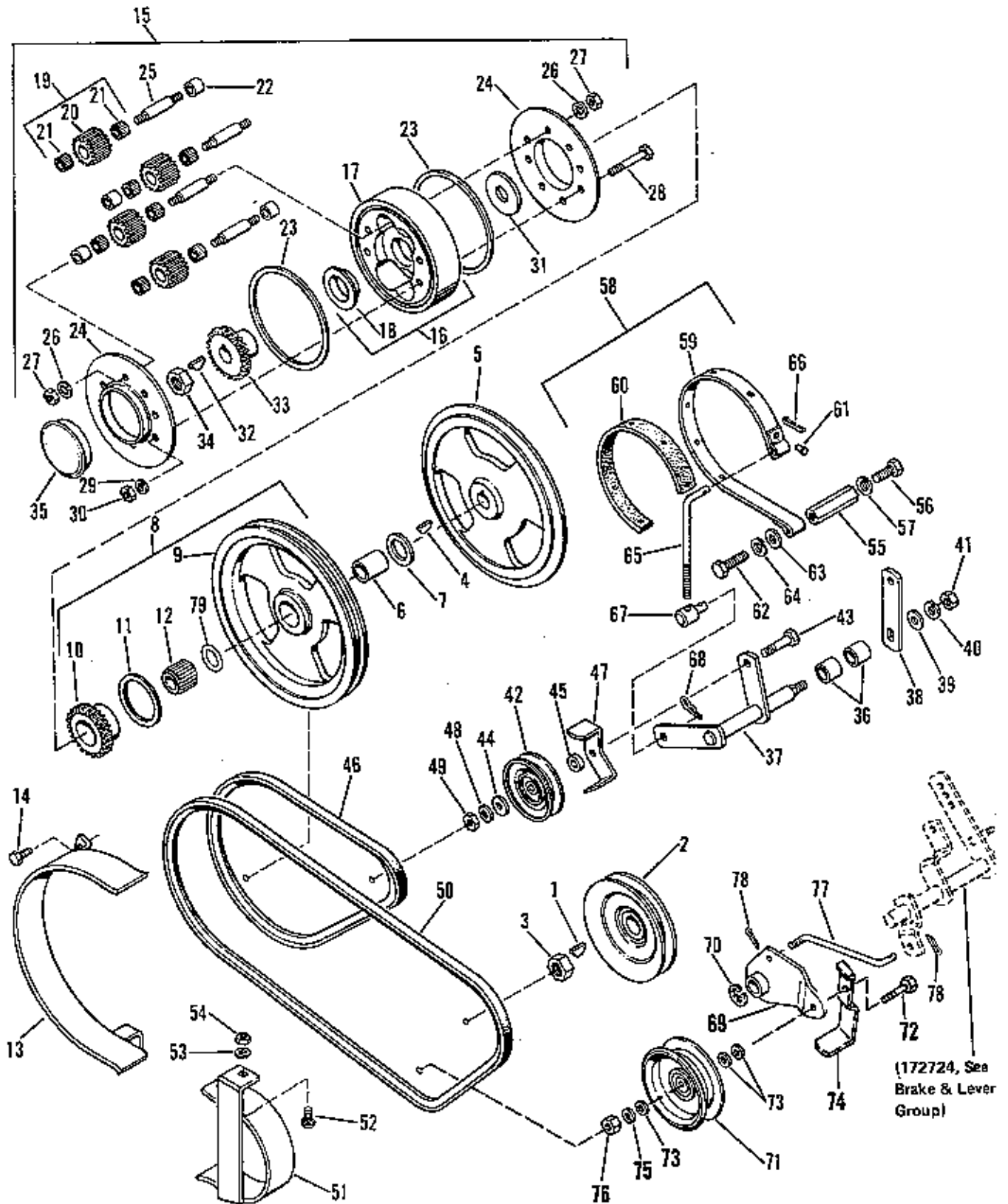

**PULLEYS & CONTROLS**

Ref. No.	Part No.	Qty.	Description
1	930670	1	KEY
2	174359	1	PULLEY
3	922133	1	NUT, Hex, Jam, 3/4"-16
4	905123	1	KEY
5	173793	1	SHEAVE, Half
6	174568	1	RACE, Inner
7	174570	1	BEARING, Thrust
8	176255	1	SHEAVE ASSEMBLY
9	173794	1	SHEAVE
10	175712	1	GEAR, Sun
11	174981	1	SEAL
12	177343	1	BEARING, Roller
13	174394	1	GUARD ASSEMBLY, Pulley
14	930601	2	SCREW, Taptite, 5/16"-18 x 5/8" lg.
15	176256	1	PLANETARY ASSEMBLY
16	174586	1	CARRIER SUB ASSEMBLY, Planetary
17	173795	1	CARRIER, Planetary
18	173789	1	BEARING, Flange
19	176257	4	PINION ASSEMBLY, Planetary
20	175710	4	PINION, Planetary
21	174567	8	BEARING, Needle
22	174569	4	BEARING, Sleeve
23	174399	2	"O" RING
24	174404	2	COVER, Differential
25	174025	4	PIN, Pinion
26	923300	8	LOCKWASHER, Shakeproof, Int.
27	917372	8	NUT, Hex, Full, 5/16"-18
28	919354	4	CAPSCREW, Hex, 5/16" -18 x 2" lg.
29	917356	4	LOCKWASHER, 5/16"
30	917372	4	NUT, Hex, Full, 5/16"-18
31	174274	1	WASHER, Thrust
32	905123	1	KEY
33	175714	1	GEAR, Sun
34	922133	1	NUT, Hex, Jam, 3/4"-16
35	174584	1	CAP, Hub.
36	118092	2	BUSHING
37	173864	1	LEVER ASSEMBLY
38	174427	1	LEVER
39	917378	1	WASHER, Plain
40	916965	1	LOCKWASHER, 3/8"
41	916950	1	NUT, Hex, Full, 3/8"-16
42	174561	1	PULLEY, Idler

Ref. No.	Part No.	Qty.	Description
43	919360	1	CAPSCREW, Hex, 3/8"-16 x 1-1/2" lg.
44	917642	1	WASHER, Plain, 5/16"
45	174870	1	SPACER
46	174883	1	"V" BELT
47	174402	1	GUIDE, Belt
48	916965	1	LOCKWASHER, 3/8"
49	916950	1	NUT, Hex, Full, 3/8"-16
50	174731	1	"V" BELT
51	174424	1	GUARD ASSEMBLY, Belt
52	922110	1	BOLT, Carriage, 3/8"-16 x 3/4" lg.
53	916965	1	LOCKWASHER, 3/8"
54	916950	1	NUT, Hex, Full 3/8-16
55	174386	1	ANCHOR, Brake
56	921210	1	CAPSCREW, Hex, 3/8" -16 x 1" lg.
57	916965	1	LOCKWASHER, 3/8"
58	174381	1	BAND ASSEMBLY, Brake
59	174382	1	BAND, Brake
60	174383	1	LINING, Brake
61	928810	6	RIVET; # 7 x 1/4" lg.
62	919360	1	CAPSCREW, Hex, 3/8"-16 x 1-1/2" lg.
63	917642	1	WASHER, Plain, 5/16"
64	917365	1	LOCKWASHER, 3/8"
65	174385	1	ROD
66	722001	1	PIN, Cotter, 3/32" x 3/4" lg.
67	108172	1	PIVOT
68	722001	1	PIN, Cotter, 3/32 x 3/4" lg.
69	173861	1	LEVER ASSEMBLY Idler
70	1602155	2	"E" RING
71	174497	1	PULLEY
72	919360	1	CAPSCREW, Hex, 3/8" -16 x 1-1/2" lg.
73	917642	3	WASHER, Plain 5/16"
74	178557	1	GUIDE, Belt
75	720002	1	LOCKWASHER, 3/8"
76	717003	1	NUT, Hex, Full, 3/8"-16
77	164088	1	LINK, Clutch
78	918447	1	PIN, Cotter, 3/32" x 3/4" lg.
79	118019	1	SEAL

# TRANSMISSION

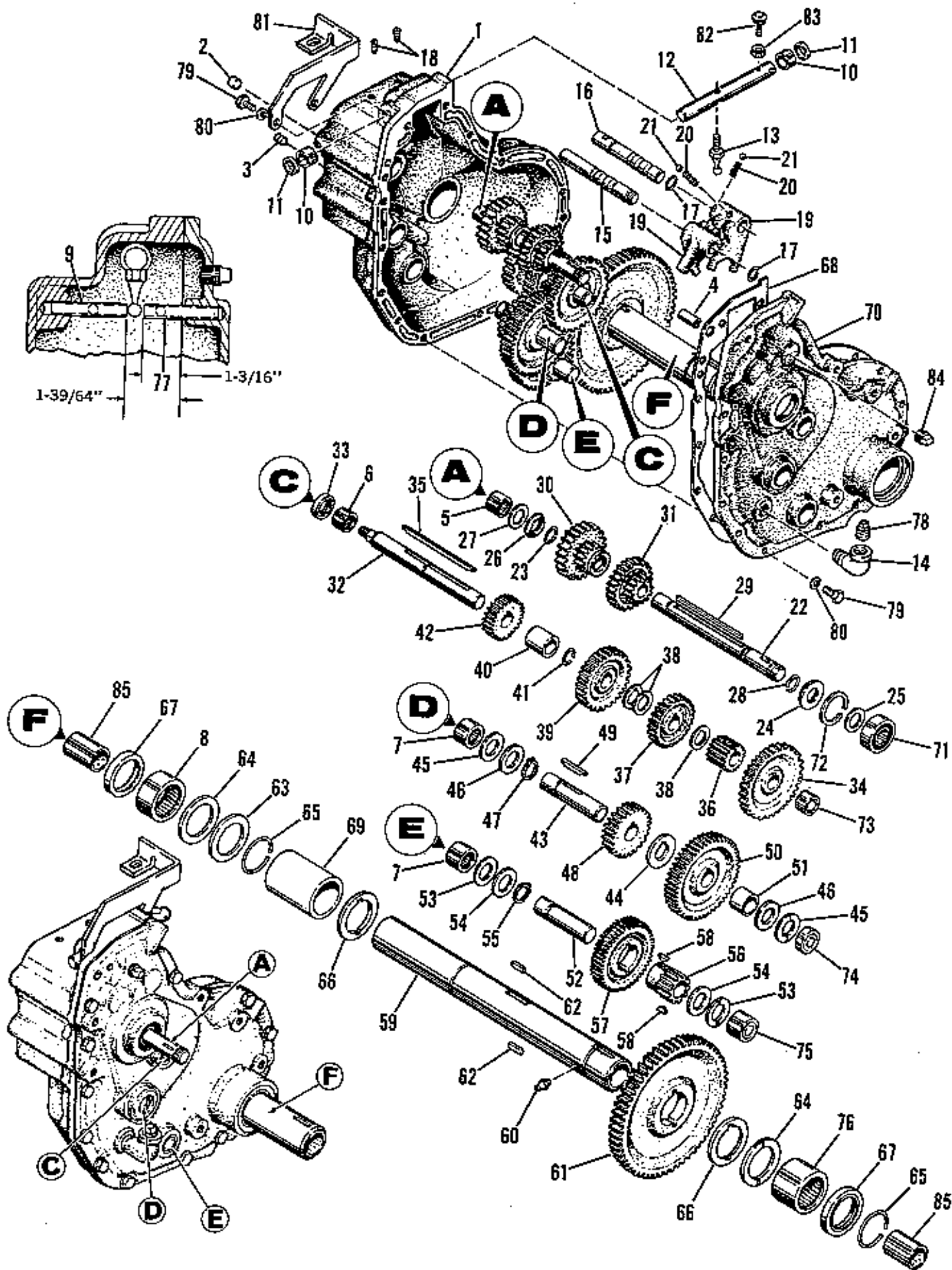

TRANSMISSION

Ref. No.	Part No.	Qty.	Description
1	174582	1	GEAR CASE SUB-ASSEMBLY W/BEARINGS (Includes 2 thru 7)
2	174583	1	PLUG, Expansion
3	929277q	1	SCREW, Set
4	918113	2	PIN, Roll, 3/8" x 1" lg.
5	154257	1	BEARING, Needle
6	154258	1	BEARING, Needle
7	154259	2	BEARING, Needle
8	157519	1	BEARING, Needle
9	154538	1	ROLL PIN SUB-ASSEMBLY
10	121084	2	SPACER
11	157619	2	SEAL, Oil
12	164260	1	ROD, Shift
13	172779	1	STEM, Shift
14	901723	1	ELBOW, 90°
15	154067	1	SHAFT, Shifter
16	154068	1	SHAFT, Shifter, Hi-Lo.
17	8061048	2	RING, Retaining
18	917231	2	SCREW, Set, 5/16-18 x 1/2" lg.
19	154069	2	FORK, Shifter
20	154323	2	SPRING
21	154262	2	BALL, Shift, Lock
22	173807	1	SHAFT, Pulley
23	118134	1	RING, Retaining
24	154462	1	WASHER
25	108472	1	WASHER
26	172982	1	WASHER
27	172981	1	WASHER
28	154264	1	RING, Retaining
29	164294	1	KEY
30	174234	1	GEAR ASSEMBLY, II & IV
31	154075	1	PINION ASSEMBLY, I & III
32	157290	1	SHAFT, I Intermediate
33	154263	1	SEAL, Oil
34	154078	1	GEAR, Driven, I
35	154354	1	KEY
36	154079	1	PINION, 1st Intermediate
37	154080	1	PINION, Driven, III
38	8061012	3	WASHER
39	154081	1	GEAR, Driven, II
40	154082	1	SPACER
41	154264	1	RING, Retaining

Ref. No.	Part No.	Qty.	Description
42	174228	1	PINION, REV. & IV
43	154086	1	SHAFT, 2nd Intermediate
44	154038	1	WASHER
45	172979	2	WASHER
46	172978	2	WASHER
47	154266	1	RING, Retaining
48	164062	1	PINION, 2nd Intermediate
49	154267	1	KEY
50	154089	1	GEAR, 2nd Intermediate
51	154090	1	SPACER
52	154091	1	SHAFT, 3rd Intermediate
53	172979	2	WASHER
54	172978	2	WASHER
55	154266	1	RING, Retaining
56	154092	1	PINION, 3rd Intermediate
57	164051	1	GEAR, 3rd Intermediate
58	910224	2	KEY
59	164222	1	TUBE AND BUSHING ASSEMBLY
60	912808	1	FITTING, Lub
61	154095	1	GEAR, Driven
62	154096	2	KEY
63	172977	2	WASHER
64	154097	1	WASHER
65	154268	2	RING, Snap
66	154130	2	WASHER
67	154269	2	SEAL
68	164234	1	GASKET, Case, Gear
69	154098	1	SPACER
70	164226	1	COVER ASSEMBLY, Case, Gear
71	108202	1	BEARING, Ball
72	164064	1	RING, Retaining
73	154257	1	BEARING, Needle
74	154271	1	BEARING, Needle
75	154259	1	BEARING, Needle
76	157520	1	BEARING, Needle
77	154537	1	ROLL PIN ASSEMBLY
78	901653	2	PLUG, Pipe
79	916431	14	CAPSCREW, Hex, 5/16"-18 x 1" lg.
80	917356	14	LOCKWASHER, 5/16"
81	164251	1	SUPPORT, Switch
82	172241	1	BOLT, Carriage, 5/16"-18 x 1" lg.
83	920161	1	NUT, Hex, Jam, 5/16"-18
84	901653	1	PLUG, Pipe
85	164224	2	BUSHING

# FRONT WHEELS, AXLE AND STEERING

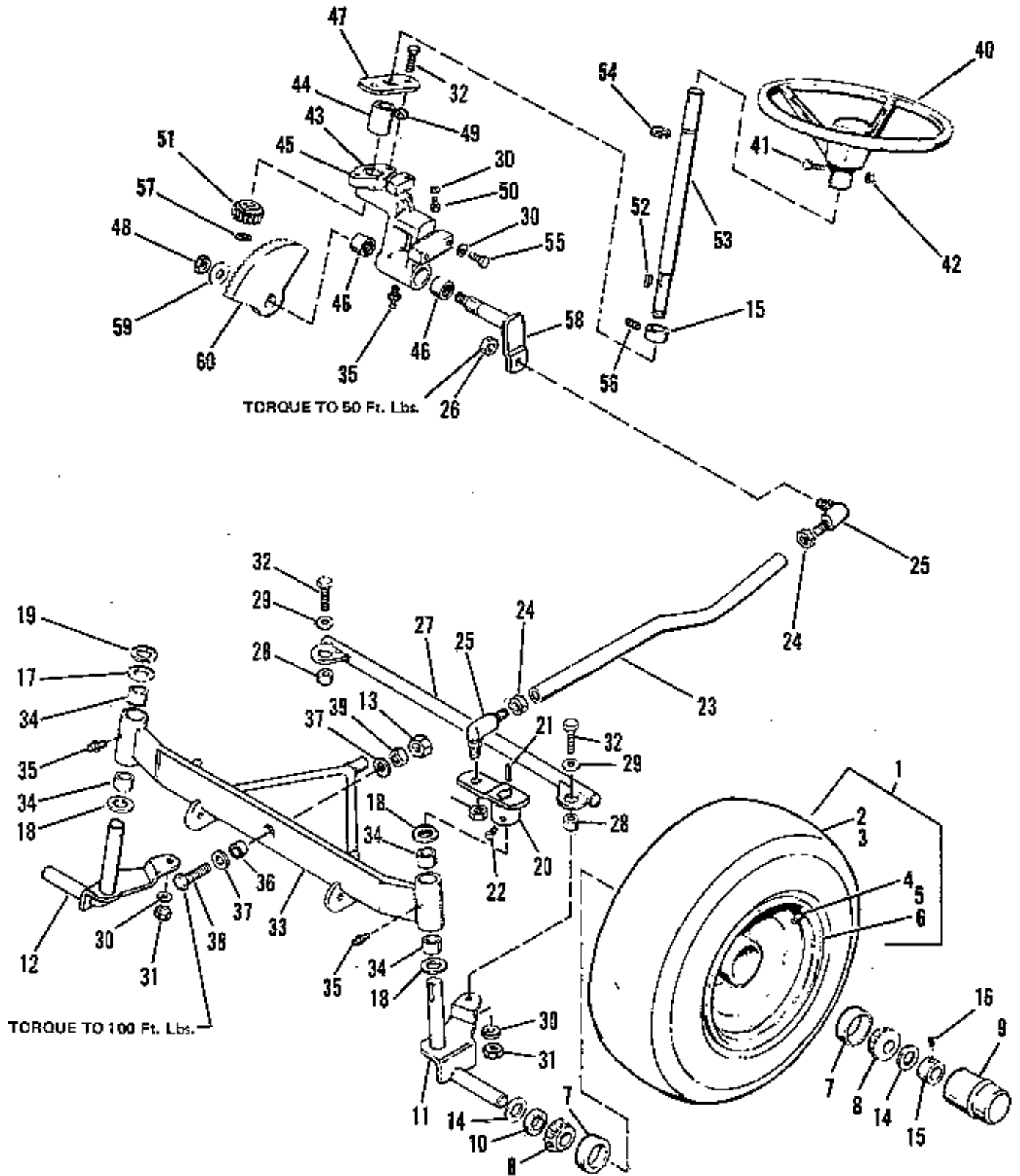

## FRONT WHEELS, AXLE AND STEERING

Ref. No.	Part No.	Qty.	Description
1	176376	2	WHEEL & TIRE ASSEMBLY
2	157490	2	TIRE
3	164247	2	TUBE
4	156305	2	STEM, Valve & Cap
5	171377	2	WHEEL, Sub Assembly
6	171378	2	WHEEL, Front
7	154393	4	CUP, Bearing
8	154486	4	CONE, Bearing
9	154487	2	CAP, Hub
10	170168	2	SEAL
11	171774	1	SPINDLE ASSEMBLY, L.H.
12	157494	1	SPINDLE ASSEMBLY, R.H.
13	922133	1	NUT, Hex, Jam, 1/2"-13
14	171375	4	SPACER
15	8021010	3	COLLAR, Set
16	928734	2	SCREW, Set, 5/16"-18 x 5/16" lg.
17	8061012	1	WASHER
18	108181	3	WASHER
19	157286	1	RING, Retaining
20	170998	1	ARM ASSEMBLY, Steering L.H.
21	157427	2	KEY
22	713006	2	SCREW, Set, 5/16"-18 x 1/2 lg.
23	171830	1	ROD, Tie
24	919262	2	Nut, Jam, 1/2"-20
25	164272	2	JOINT, Ball
26	930633	2	NUT, Hex, Jam, Lock, 1/2"-20
27	157499	1	LINK ASSEMBLY, Drag
28	174177	2	SPACER
29	917378	2	WASHER, Plain 3/8"
30	916965	5	LOCKWASHER, 3/8"
31	916950	2	NUT, Hex, Full, 3/8"-16

Ref. No.	Part No.	Qty.	Description
32	917400	4	CAPSCREW, Hex, 3/8"-16 x 1-1/4" lg.
33	157616	1	AXLE ASSEMBLY, Front
34	154289	4	BUSHING
35	727001	3	FITTING, Grease
36	157618	1	SPACER
37	918431	2	WASHER, Plain, 1/2"
38	927469	1	CAPSCREW, Hex
39	930648	1	NUT, Toplo, 1/2"-13
40	1606342	1	WHEEL, Steering
41	921977	1	CAPSCREW, Hex, 5/16"-18 x 1-1/4" lg.
42	929001	1	NUT, Flange, Lock, 5/16"-18
43	170960	1	CASTING, Steering
44	170992	1	BUSHING
45	171832	1	CASTING w/Bearings
46	154258	2	BEARING, Needle
47	171000	1	PLATE, Steering
48	924058	1	NUT, Hex, Full, Lock 7/16-14
49	928731	2	NUT, Hex, Lock, Jam, 3/8"-16
50	921965	1	CAPSCREW, Hex, 3/8"-16 x 3/4" lg.
51	170988	1	PINION
52	910224	1	KEY
53	171020	1	SHAFT, Steering
54	154264	1	RING, Retaining
55	919357	2	CAPSCREW, Hex, 3/8"-16 x 7/8" lg.
56	928691	1	SCREW, Set, 5/16"-18
57	1602155	1	RING, "E"
58	170999	1	ARM ASSEMBLY, Steering
59	918430	1	WASHER, Plain, 7/16"
60	170987	1	GEAR

# REAR LIFT AND DRAW BAR

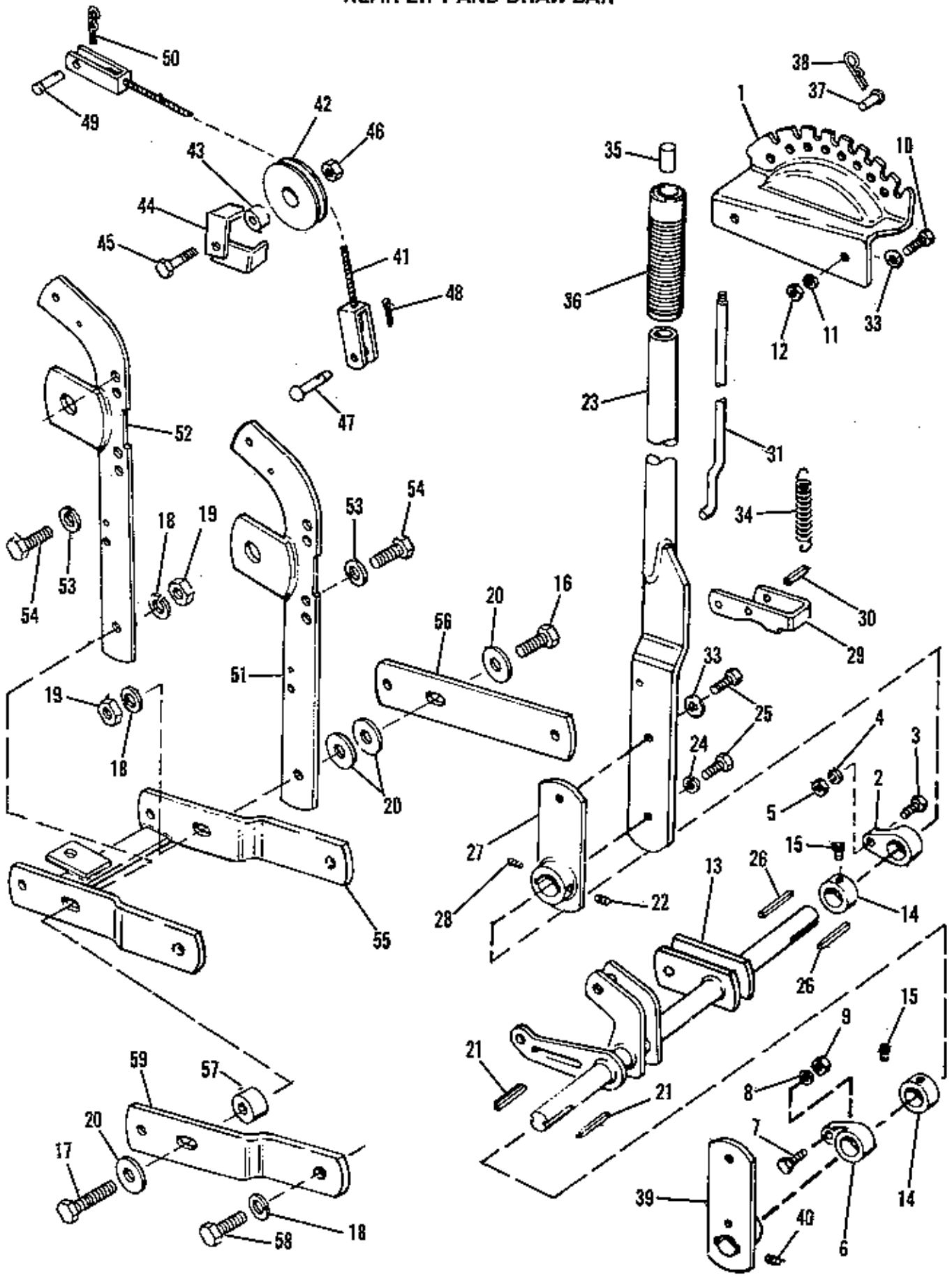



**REAR LIFT AND DRAW BAR**

Ref. No.	Part No.	Qty.	Description
1	171599	1	QUADRANT, Lift Lever
2	170975	1	BEARING, Lift Lever
3	921977	1	CAPSCREW, Hex, 5/16"-18 x 1-1/4" lg.
4	917356	1	LOCKWASHER, 5/16"
5	917372	1	NUT, Hex, Full, 5/16"-18
6	170975	1	BEARING, Lift Lever
7	921977	1	CAPSCREW, Hex, 5/16-18 x 1-1/4" lg.
8	917356	1	LOCKWASHER, 5/16"
9	917372	1	NUT, Hex, Full, 5/16"-18
10	908127	2	CAPSCREW, Hex, 3/8"-16 x 3/4" lg.
11	916965	2	LOCKWASHER, 3/8"
12	916950	2	NUT, Hex, Full, 3/8"-16
13	174111	1	SHAFT ASSEMBLY, Lift
14	157624	2	COLLAR, Set
15	928709	2	SCREW, Set, 5/16"-18 x 3/8" lg.
16	916608	1	CAPSCREW, Hex, 7/16"-14 x 1-1/2" lg.
17	916609	1	CAPSCREW, Hex, 7/16"-14 x 1-3/4" lg.
18	918199	3	LOCKWASHER, 7/16"
19	918213	2	NUT, Hex, Full, 7/16"-14
20	917642	4	WASHER, Plain, 5/16"
21	157652	2	KEY
22	928734	1	SCREW, Set, 5/16"-18 x 1/4" lg.
23	171589	1	LEVER ASSEMBLY, Lift
24	916965	2	LOCKWASHER, 3/8"
25	922763	2	CAPSCREW, Hex, 3/8"-16 x 1" lg.
26	157652	2	KEY
27	171593	1	LEVER ASSEMBLY, Lift
28	928734	1	SCREW, Set, 5/16"-18 x 1/4" lg.
29	173039	1	LATCH, Lift Lever

Ref. No.	Part No.	Qty.	Description
30	918390	1	PIN, Roll, 3/8" x 1-1/4" lg.
31	1651197	1	ROD, Latch
33	917642	2	WASHER, Plain, 3/8"
34	1650155	1	SPRING
35	1650157	1	BUTTON, Thumb
36	156209	1	GRIP, Handle
37	153058	1	PIN
38	8161045	1	CLIP, Spring
39	157625	1	LEVER ASSEMBLY, Front Lift
40	171593	1	SCREW, Set, 5/16"-18 x 1/4" lg.
41	174085	1	CABLE ASSEMBLY, Lift
42	172725	1	PULLEY
43	157081	1	SPACER
44	174723	2	GUARD, Cable
45	108418	1	SCREW
46	928731	1	NUT, Hex, Jam, Lock, 3/8-16
47	174215	1	PIN
48	916241	1	PIN, Cotter, 3/32" x 7/8" lg.
49	153058	1	PIN
50	8161045	1	CLIP, Spring
51	164304	1	ARM ASSEMBLY
52	164284	1	ARM ASSEMBLY
53	918199	4	LOCKWASHER, 7/16"
54	918212	4	CAPSCREW, 7/16"-14 x 1" lg.
55	154202	1	DRAW BAR ASSEMBLY
56	157091	1	BAR, Pull
57	1608759	1	SPACER
58	919364	1	CAPSCREW, 7/16"-14 x 2-1/4" lg.
59	154203	1	BAR, Draw

