

# ***Simplicity***®

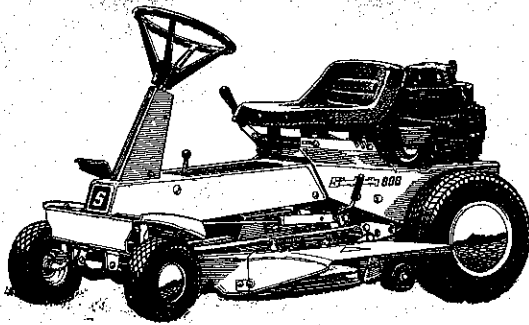

## **OWNER'S MANUAL**

With  
**ILLUSTRATED PARTS LIST**

MFG. NO. 998 WONDER-BOY 808 ELECTRIC START  
MFG. NO. 1000 WONDER-BOY 808 MANUAL START  
MFG. NO. 1030 REAR MOUNTED GRASS CATCHER

SIMPLICITY MANUFACTURING COMPANY, INC.



**1653** #

SER. FORM - 178081  
LITHO IN U.S.A.

## TABLE OF CONTENTS

SECTION		PAGE
1.	Specifications . . . . .	1
2.	Safety Instructions . . . . .	2
3.	Operating Instructions . . . . .	4
4.	Troubleshooting . . . . .	8
5.	Adjustments . . . . .	10
6.	Maintenance . . . . .	13
7.	Storage . . . . .	19
8.	Parts Listing . . . . .	19

### SIMPLICITY'S NEW EQUIPMENT WARRANTY

The Company warrants Simplicity products to be free from defects in material and workmanship, except the Company makes no warranty, express or implied, with respect to tires, engines, generators and voltage regulators, which are warranted by their respective manufacturers. Any part covered by this warranty which is proven defective within one year (45 days for equipment used for rental, municipal or commercial purposes) under normal use, from date of purchase, will be replaced without charge, provided such part is returned to the factory, (if requested), and is found to be defective upon examination at the factory. This warranty does not apply to any Simplicity products altered outside of the Simplicity factory. THE FOREGOING WARRANTY IS IN LIEU OF ALL OTHER WARRANTIES, EXPRESS OR IMPLIED, OF MERCHANTABILITY, FITNESS FOR A PARTICULAR PURPOSE, PERFORMANCE, OR OTHERWISE. The Company's obligation under its warranty is strictly and exclusively limited to the replacement of such parts, and in no event shall the Company be liable for any other damages, whether direct, immediate, incidental, special, or consequential. Simplicity Manufacturing Company, Inc., reserves the right to modify or change specifications without prior notification. There are no warranties which extend beyond the description of any Simplicity product.

## SECTION 1. SPECIFICATIONS

### SPECIFICATIONS SUBJECT TO CHANGE WITHOUT NOTICE

<b>1-1 ENGINE</b>							
Make	Briggs & Stratton						
Model No.	190707 (MFG. No. 998) 190702 (MFG. No. 1000)						
Type	0789-01						
Horsepower	8 @ 3600 rpm (Engine Mfr. Rating)						
Cycles	4						
Cylinders	1						
Bore	3 inches						
Stroke	2-3/4 inches						
Displacement	19.44 Cu. In.						
Crankshaft	Vertical						
Starter	Automatic Rewind or Electric						
Ignition	Magneto						
Governor	Adjustable Mechanical Type 1800-3400 range						
Air Cleaner	Sealed Housing, Reusable Oiled Foam Element						
Choke	Chokematic						
Crankcase	Lubrication: Gear Impeller System Oil Capacity: 2-1/4 Pints						
Fuel Capacity	3 Quarts						
Muffler	Quiet Rear Discharge						
<b>1-2 TRANSMISSION</b>							
Type	2 Speed Range Shuttle Drive with Split Sheave						
Speeds	Two Forward, Two Reverse						
Speed Range (at 3400 rpm)	<table style="display: inline-table; border-collapse: collapse;"> <thead> <tr> <th style="padding: 0 10px;">Forward</th> <th style="padding: 0 10px;">Reverse</th> </tr> </thead> <tbody> <tr> <td style="padding: 0 10px;">Low: 2.52 mph</td> <td style="padding: 0 10px;">2.52 mph</td> </tr> <tr> <td style="padding: 0 10px;">High: 3.92 mph</td> <td style="padding: 0 10px;">3.92 mph</td> </tr> </tbody> </table>	Forward	Reverse	Low: 2.52 mph	2.52 mph	High: 3.92 mph	3.92 mph
Forward	Reverse						
Low: 2.52 mph	2.52 mph						
High: 3.92 mph	3.92 mph						
Differential	Type: All gear, fully enclosed and lubricated						
<b>1-3 ROTARY MOWER</b>							
Mounting	Suspended from and Tilts with Front Axle						
Width of cut (Blade)	30 inches						
Height of cut	1-1/2 to 3-1/2 inches						
Drive	Cushioning V-Belt with Lever Control						
Adjustment	Stepless Screw Controls Front and Rear Height						
Spindles	Sealed Rolling Contact Bearing Mounted						
Rear Support	Three Rollers, 2 at 2 inch, 1 at 3-15/16 " Wide						
Housing	Drawn Steel, Height above blade in clipping channel area increases from 2-1/2 to 4-1/8 inches above blade.						
<b>1-4 CHASSIS</b>							
Frame	Heavy Gauge Steel-Front and Rear U-Channel						
Rear Tires	Inflation Pressure: 10 psi Size: 16.00/6/50 x 8 Turf Tread Tread Width: 28 inches						

#### 1-4 CHASSIS (Continued)

Front Tires	Pneumatic, Inflation Pressure: 22 to 25 psi Size - 4.10/3.50 x 4 Turf Tread Bearings: Powdered Iron with Grease Fittings Tread Width: 28 inches
Seat	Type: Bucket, Rubber Mounted Cover: Leatherette on bonded foam
Turning Radius Stability	Inside Rear Tire: 22 inches For increased stability and traction, install rear wheel weights.

#### 1-5 CONTROLS

Steering	Control: Steering Wheel Type System: 3.81 to 1 Ratio
Clutch and Brake Pedal	Location: Right Front Clutch: Soft Action, Touch-O-Matic, V-Belt Brake: Foot Operated Band Type
Gear Selector	Location: Right side of seat
Mower Clutch	Location: Left side of seat
Throttle Control	Location: Front center of seat
Starter	Location: Manual: Rear right side of engine, has automatic choke Location: Electric: Key under right side of seat, has automatic choke

#### 1-6 DIMENSIONS

Overall Length	57-3/4 Inches
Overall Width	Without Mower 28-1/4 Inches With 30 Inch Mower and Safety Shield: 40-1/4 Inches
Wheel Base	44-3/8 Inches
Shipping Weight	With 30 Inch Mower: 406 Lbs. Manual With 30 Inch Mower: 416 Lbs. Electric

## SECTION 2. SAFETY INSTRUCTIONS

### TRAINING

1. Read the Owner's Manual carefully. Be thoroughly familiar with the controls and proper use of the equipment. On riding vehicles, know how to stop quickly.
2. Never allow children to operate a power mower or riding vehicle. Never allow adults to operate any equipment without proper instruction.
3. Keep the area of operation clear of all persons, particularly small children, and pets.
4. Do not carry passengers.
5. Check fuel before starting engine. Do not fill gasoline tank indoors, when engine is running, or while engine is still hot. Wipe off any spilled gasoline before starting engine. Do not run engine indoors.
6. Disengage self-propelled mechanism or drive clutch on units so equipped before starting engine (motor).
7. Never attempt to make a wheel height adjustment while engine (motor) is running.
8. Mow only in daylight or in good artificial light.

### PREPARATION

1. Thoroughly inspect the area where the equipment is to be used and remove all stones, sticks, wire, bones and other foreign objects.
7. Never operate equipment in wet grass. Always be sure of your footing on walk-behind units; keep a firm hold on the handle and walk; never run.
8. Check battery water level and state of charge.

## OPERATION

1. Do not change engine governor settings or over-speed engine.
2. Do not put hands or feet near or under rotating parts. Keep clear of discharge opening at all times.
3. Stop blade(s) when crossing gravel drive, walks or roads.
4. After striking a foreign object, stop the engine (motor), remove wire from spark plug, thoroughly inspect the mower for any damage, and repair the damage before restarting and operating the mower.
5. If the equipment should start to vibrate abnormally, stop the engine (motor) and check immediately for the cause. Vibration is generally a warning of trouble.
6. Stop engine (motor) whenever you leave the equipment, before cleaning mower housing, and when making any repairs or inspections.
7. On riding vehicles, take all possible precautions when leaving vehicle unattended; such as disengaging power-take-off, lowering attachments, shifting into neutral, setting parking brake, stopping engine and removing key.
8. When cleaning, repairing or inspecting, make certain blade and all moving parts have stopped. Disconnect spark plug wire and keep wire away from plug to prevent accidental starting.
9. Do not run engine indoors.
10. Shut engine (motor) off and wait until blade comes to a complete stop before removing grass catcher and/or unclogging chute.
11. Mow up and down slopes with riding vehicles. Exercise extreme caution when changing direction on slopes. Do not mow excessively steep slopes (greater than 40% grade).
12. Always bring the unit to a complete stop before cleaning, repairing and adjusting.
13. Never operate mower without proper guards, plates or other safety protective devices in place.
14. Keep washout ports and other mower housing service openings closed when mowing.
15. Stay alert for holes in terrain and other hidden hazards.
16. On riding vehicles, use care when pulling loads or using heavy equipment.
  - A. Use only approved drawbar hitch points.
  - B. Limit loads to those you can safely control.
  - C. Do not turn sharply. Use care when backing.
  - D. Use counterweight(s) or wheel weights when suggested in owner's manual.
17. Watch out for traffic when crossing or near roadways.
18. Never direct discharge of material toward bystanders nor allow anyone near vehicle while in operation.

## MAINTENANCE AND STORAGE

1. On riding vehicles, disengage power to attachments and stop engine (motor) before leaving operator's position, making any repairs or adjustments, when transporting, or when not in use.
2. Check blade and engine mounting bolts at frequent intervals for proper tightness.
3. Keep all nuts, bolts, and screws tight to be sure equipment is in safe working condition.
4. Never store equipment with gasoline in the tank inside of a building where fumes may reach an open flame or spark. Allow engine to cool before storing in any enclosure.
5. To reduce fire hazard keep engine free of grass, leaves or excessive grease.
6. Check grass catcher bags frequently for wear or deterioration. Replace with new bags for safety protection.

## SECTION 3. OPERATING INSTRUCTIONS

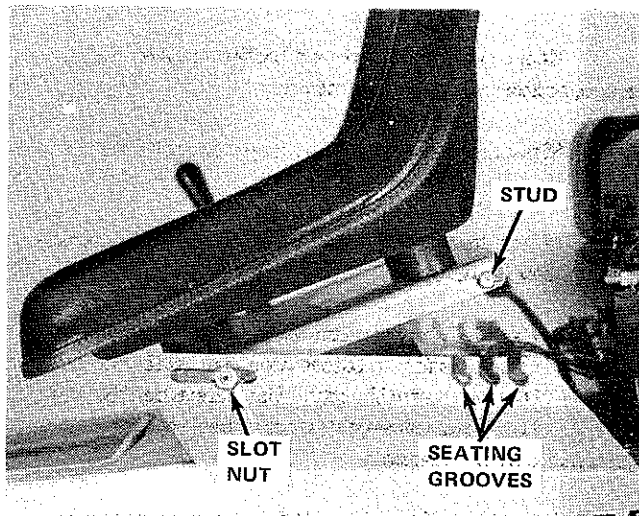

Figure 3-1. Seat Adjustment

### 3-1 BEFORE STARTING

A. The seat has three sitting positions (Figure 3-1). To adjust for a comfortable position, tilt the seat forward and slide studs in to desired groove. Slot nuts should be tightened to allow free movement of seat assembly.

B. Familiarize yourself with the following control operations:

1. Clutch and Brake Foot Pedal (Figure 3-2). Push pedal down to declutch and apply brake simultaneously. Vehicle may be stopped by depressing clutch pedal or by retaining direction control lever to NEUTRAL without depressing clutch pedal.

2. Throttle Lever (Figure 3-3). Move lever FORWARD to increase speed and toward REAR to slow speed. Mowing should be done at 3/4 to full throttle.

3. Mower Height Adjuster (Figure 3-2). The height adjusting handle raises and lowers the mower at both front and rear. Turn handle CLOCKWISE to raise, COUNTER-CLOCKWISE to lower.

4. Gear Shift Lever (Figure 3-2). Depress clutch and brake foot pedal and place the shift lever in the desired position. The upper position places the transmission in LOW gear, the middle position in NEUTRAL, and the lower position in HIGH gear (Figure 3-9). Gear shift lever must be in NEUTRAL when starting.

5. Direction Control Lever (Figure 3-2). The direction control lever controls the direction of travel. To position lever in either FORWARD, NEUTRAL, OR REVERSE, it is necessary to pull handle inward from notch and then move either forward or rearward as desired.

6. Mower Clutch Lever (Figure 3-3). When mower is engaged the clutch lever is forward and down. Engine

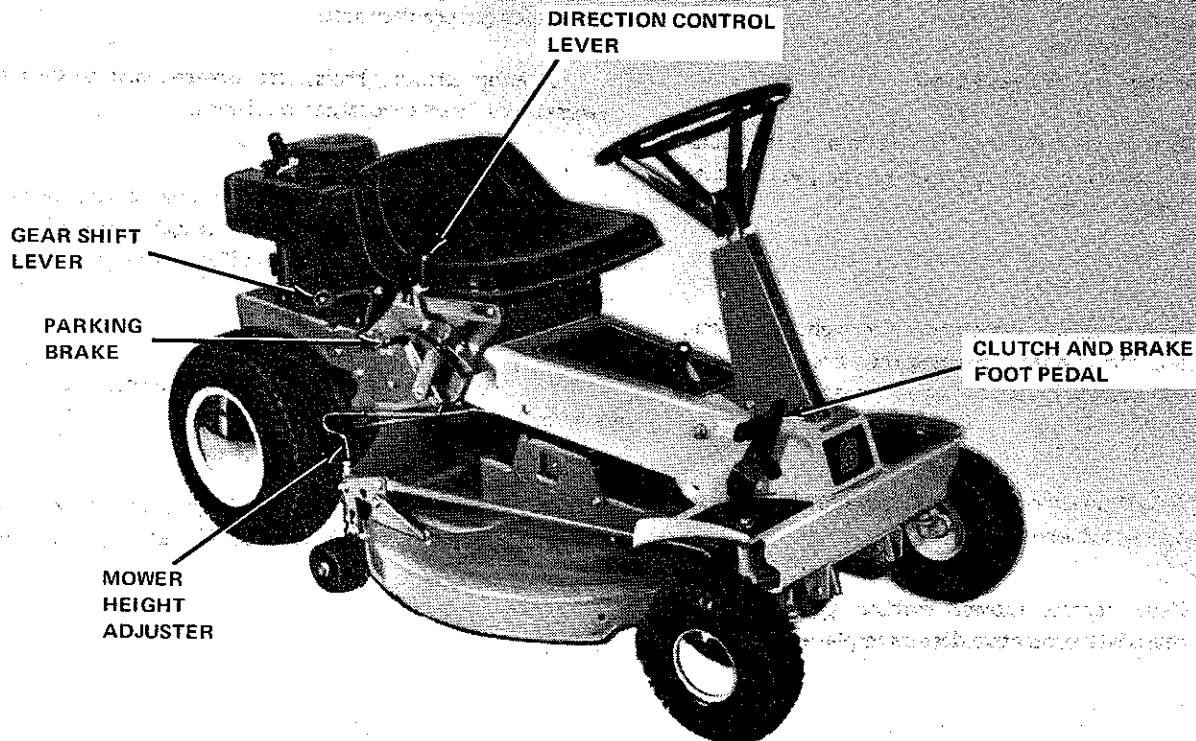

Figure 3-2. Right Side Operation Controls

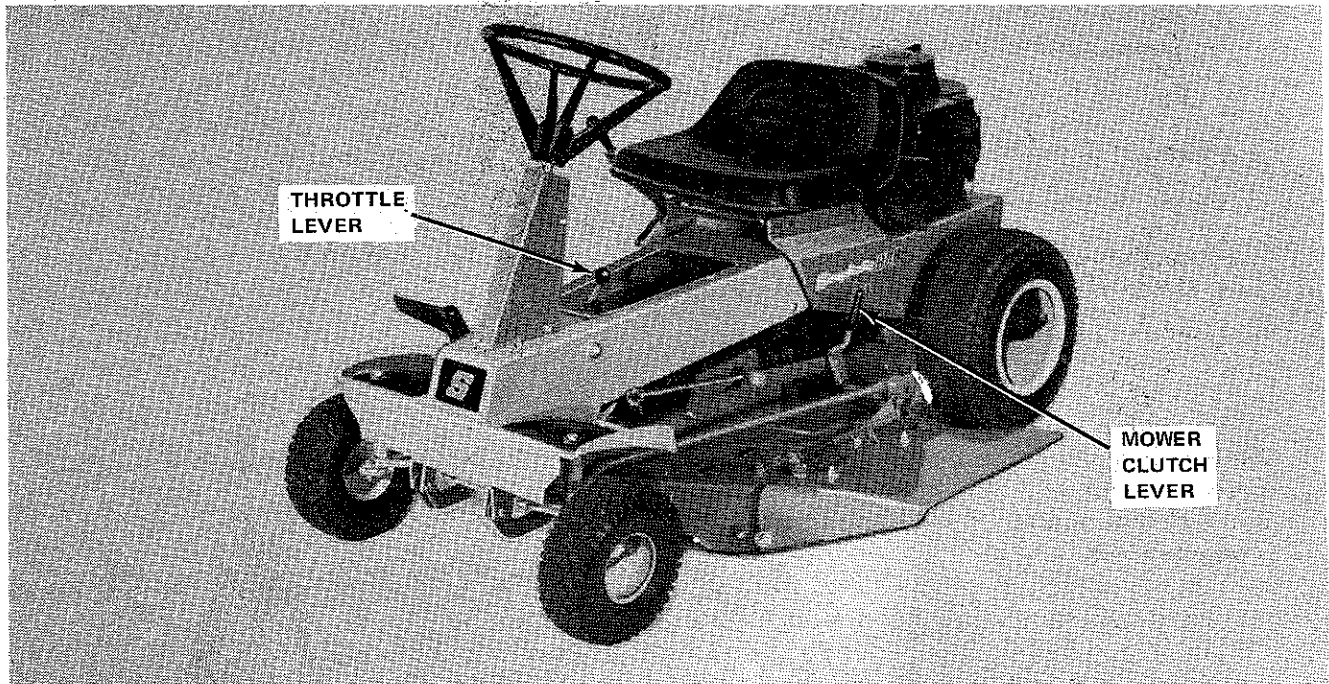

Figure 3-3. Left Side Operation Controls

should be running 3/4 to full speed when the mower drive is engaged. Mower clutch lever must be disengaged before starting engine.

7. Parking Brake (Figure 3-2). To apply parking brake, push lever down.

C. Before attempting to start the engine, read the engine owner's manual thoroughly. Be sure to have on hand sufficient quantities of "Regular" grade gasoline and 10W-30 grade SD/CC, MS, MS/DG, or MS/DM motor oil. (Par. 6-1).

D. Remove the engine crankcase filler cap and gauge (Figure 3-4). Fill the crankcase with 10W-30 grade SD/CC, MS, MS/DG, or MS/DM oil until level reads full on gauge. Crankcase capacity is 2-1/4 pints. Check oil level

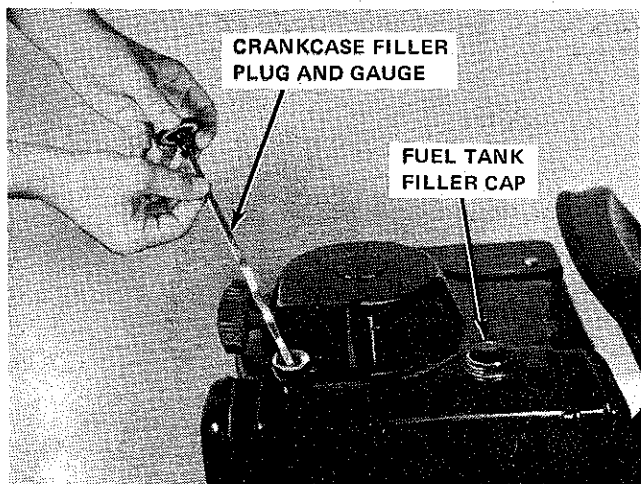

Figure 3-4. Oil and Fuel Fill Locations

every time fuel is added. Use caution not to overfill engine crankcase with oil.

E. Remove the fuel tank filler cap and fill the tank completely with clean, fresh "Regular" grade gasoline. Use a can with a flexible spout.

**CAUTION**

**DO NOT MIX OIL WITH GASOLINE**

**WARNING**

**GASOLINE IS HIGHLY INFLAMMABLE. AVOID OVERFILLING AND WIPE UP ANY SPILLED FUEL. ALLOW NO OPEN FLAME, SMOKING OR MATCHES NEAR THE AREA WHEN REFUELING.**

Replace the filler cap securely. Store gasoline in small quantities. Prolonged storage produces harmful gum and deposits. If it is necessary to store gasoline for prolonged periods, add STA-BIL brand gasoline stabilizer, available at your Simplicity dealer. (See Section 7, Storage).

F. Check tire pressure. Front tires should be 22 to 25 psi and rear tires 10 psi.

G. Check lubrication. (See Section 6, Maintenance.)

H. Adjust mower front-to-rear pitch as follows:

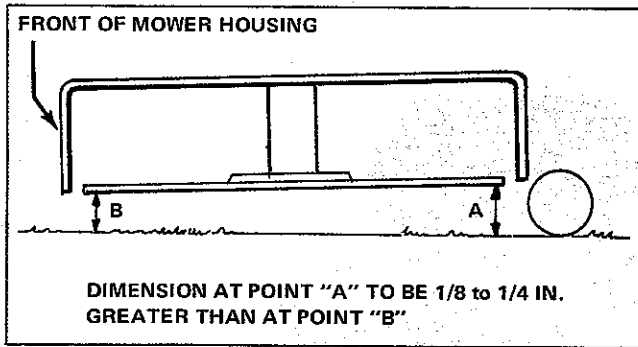

Figure 3-5. Cutting Height Measurement

**NOTE**

This adjustment is not necessary to perform for each start-up, merely a check of blade tip-to-ground distance is necessary and adjustments made accordingly.

1. Move mower to a flat, smooth surface.

**CAUTION**

Be sure engine is not running, transmission is in neutral and mower drive is disengaged (clutch lever up). Block the wheels, front and rear, to prevent rolling while working on the mower blade.

2. Position blade tips pointing front to rear.

3. Measure distance from blade tips to ground. Dimension at point "A" must be level to 1/8" higher or 1/8" lower than at point "B" (Figure 3-5).

4. To obtain the above blade setting, remove the eyebolts from both sides of the bracket (Figure 3-6) loosen locknut and adjust turnbuckle until the blade obtains the desired setting. Tighten locknut and secure eyebolt on bracket.

I. Familiarize yourself with starting and stopping (Par. 3-2) and operation (Par. 3-3) procedures.

**3-2 STARTING AND STOPPING**

A. Place controls (Figures 3-2 and 3-3) in following positions:

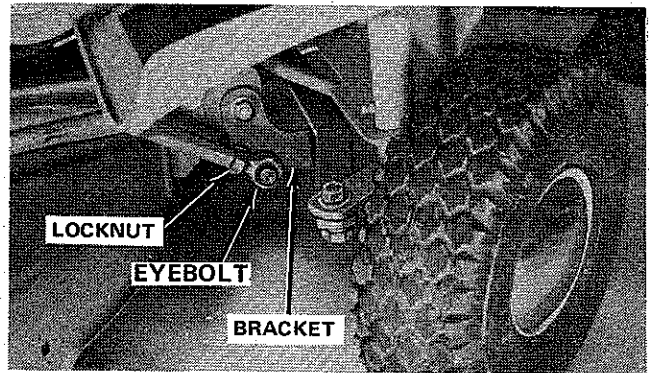

Figure 3-6. Mower Front-To-Rear Pitch Adjustment

1. Throttle lever completely forward. (Figure 3-8).
2. Gear Shift Lever-NEUTRAL (Figure 3-9).
3. Direction Control Lever-NEUTRAL (Figure 3-10).
4. Mower Clutch Lever-Disengaged, lever up (Figure 5-2).
5. Turn ignition key to "On" position.

**NOTE**

If gear shift lever not in NEUTRAL or mower clutch lever engaged (lever down), engine will crank but not start.

**B. Electric**

1. Locate ignition switch under right side of drivers seat.
2. Insert ignition key and turn clockwise until starter actuates.
3. When engine starts, release key and move throttle lever slightly rearward so engine is no longer choked.
4. To stop engine, turn ignition key counter-clockwise until vertical and remove key to prevent unauthorized starting.

**C. Manual**

**NOTE**

Use the following procedures on electric start models, should the electric start fail to function.

1. Grasp recoil starter handle firmly and pull sharply straight out.

**CAUTION**

Do not release starter handle with rope extended. Return rope to cover by hand.



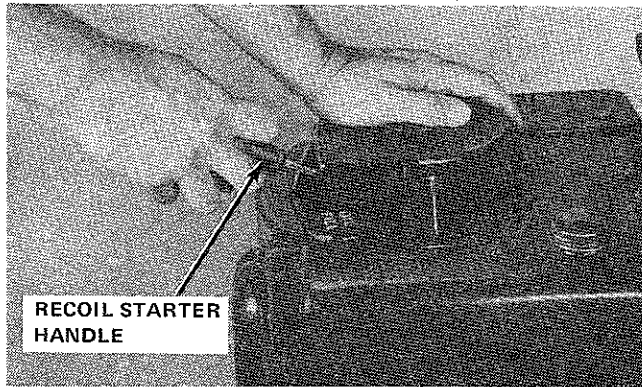

Figure 3-7. Manual Starting

2. If engine fails to start after 4 or 5 pulls, it may be flooded, the choke may not be set properly. If flooding is suspected, move throttle lever rearward and attempt starting again.

3. When engine starts, move throttle lever slightly rearward so engine is no longer choked.

4. To stop engine, turn ignition key to OFF position.

### 3-3 VEHICLE OPERATION

A. Seat yourself on mower and move throttle lever forward to give full engine speed.

B. Depress the clutch-brake pedal. This disengages the transmission for shifting and applies the brake at the same time.

C. Have the front wheels centered straight ahead and hold the steering wheel with one hand. Move the gear shift lever to HI or LO as desired. (Figure 3-9.) Remember to push downward for HIGH gear or lift upward for LOW gear on the shift lever.

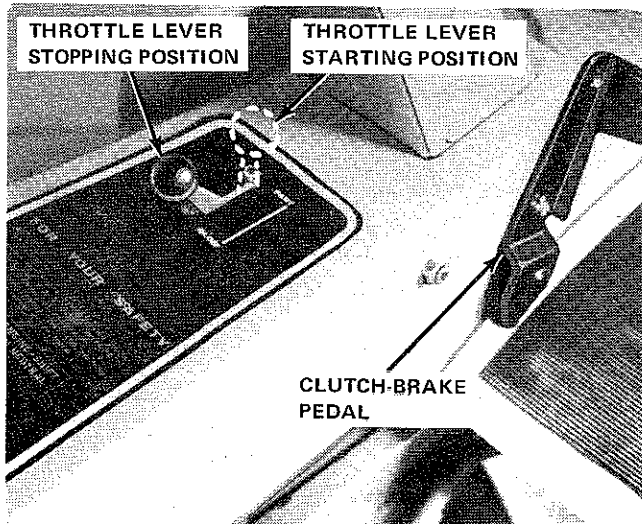

Figure 3-8. Throttle Lever Positioning and Clutch Brake Pedal

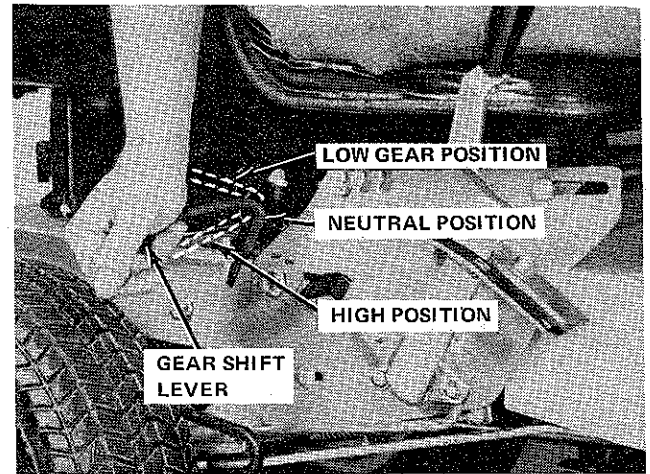

Figure 3-9. Gear Shift Lever Positioning

#### CAUTION

Change gears only when machine is motionless, lever is in NEUTRAL, and foot pedal is depressed.

D. Release brake and clutch pedal (Figure 3-8).

E. Slowly move direction control lever forward until vehicle begins moving (Figure 3-10). Continue lever movement until it is locked in FORWARD position. Vehicle should now be moving.

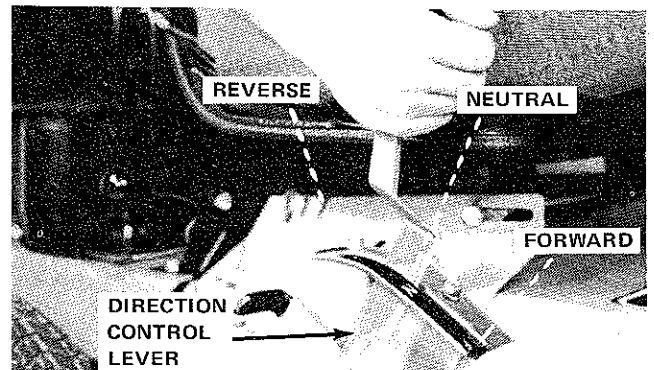

Figure 3-10. Direction Control Lever Positioning

F. Drive on level ground until you get the "feel" of machine. To stop forward or rearward motion, place direction control lever in NEUTRAL or depress clutch and brake pedal. Try slower throttle settings, shift gears, practice steering and handling in forward and reverse until you are ready to start mowing.

H. To stop, depress clutch and brake pedal and put gear shift and direction control lever in NEUTRAL. Move throttle lever back to SLOW. Turn ignition key to "Off" position.

### 3-4 VEHICLE-MOWER OPERATION

A. Check mower cutting height and adjust accordingly. (See Section 5, Adjustments.)

B. Start Engine, (Par. 3-2). Set throttle lever at 3/4 to full speed.

C. Engage mower by pushing mower clutch lever down.

D. Operate vehicle with mower referring to Par. 3-3 and the following.

E. For the first use of the mower, choose a smooth, level area. Cut long, straight strips overlapping slightly. After getting used to the operation, proceed to inclines or rough ground.

F. Guide the right side of the mower along trees, posts or other obstacles and follow the contour as closely as possible.

G. DISPERSAL: If the clippings are to remain on the lawn, mow with the discharge side toward the area already cut. If the clippings will be raked up later and the grass is at a normal height of 3 inches or less, it is practical to disperse the clippings into the un-cut area. There they will be concentrated in the center of the lawn for minimum raking.

H. WET, THICK OR HEAVY GRASS: Start at the outer edge of the area and mow counterclockwise so that clippings are always deposited on cut grass. Less engine power is required and a more even cut free of streaks will result.

I. HEIGHT SETTING: On thick or springy grass, do not set the cutting height too low. The wheels may sink

into the lawn, resulting in too short a cut. (See Section 5, Adjustments.)

J. For best appearance, new grass should be cut in the afternoon or evening when it is free of moisture.

K. Change patterns occasionally to eliminate matting, graining and a corrugated appearance. See diagram on Figure 3-11. To collect lawn clippings, a vacuum collector is available from your Simplicity dealer.

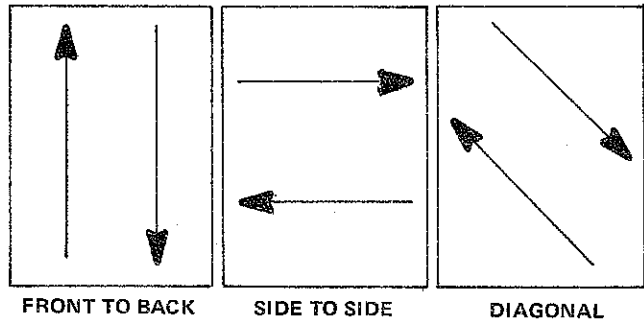

Figure 3-11. Mowing Patterns

**CAUTION**

If you feel severe vibration when mowing, the blade is unbalanced. Have it balanced before further use. (See Section 6, Maintenance.)

**SECTION 4. TROUBLESHOOTING**

**4-1 TROUBLESHOOTING**

If a specific problem and remedy is not covered herein, proceed to isolate the system in which the problem occurs

and then locate the defective part. The greater the number of symptoms of problems, the easier the remedy will be.

PROBLEM	PROBABLE CAUSE	REMEDY
Engine fails to crank	Defective battery. Defective ignition system.	Charge, then replace if not hold charge. Refer to servicing dealer.
Engine cranks but fails to start.	Throttle lever not completely forward. Gear shift lever in HI or LO. Mower clutch lever down in engaged position. Spark plug cable disconnected. No gasoline at carburetor. Interlock wires (green) cut. Interlock switch broke.	Push lever forward. Move lever to NEUTRAL. Move mower clutch lever up to disengaged position. Connect spark plug cable. Clean fuel lines and vent holes. Check fuel level Replace module. Replace switch.

PROBLEM	PROBABLE CAUSE	REMEDY
Belt slippage.	Belts excessively worn. Pulleys greasy or oily. Broken or worn belt tension spring. Belt not adjusted properly.	Replace belts. Clean pulleys. Replace spring. Adjust (Section 5).
Drive belts jump pulley.	Too much belt slack. Belt stops out of position.	Tighten belt (Section 5). Position stops (Section 5).
Belt breaks.	Sharp edges and rough spots on pulleys. Pulleys misaligned. Belt tension too tight. Old belt.	File sharp edges or replace pulley if excessively damaged. Remove pulley and check alignment. Relieve tension. Replace.
Difficult handling	Controls or drive systems out of adjustment. Tires under-inflated.	Adjust (Section 5). Inflate front tires 22-25 psi. Rear tires 10 psi.
Wheels spinning on slopes.	Wet grass. Surface too steep.	Allow grass to dry sufficiently. Add wheel weights for added traction.
Uneven cut.	Mower not adjusted properly. Mower housing bent or damaged. Blade arbor tube bent.	Adjust (Section 5). Repair or replace if excessively damaged. Straighten or replace if unusually bent.
Poor or rough cut.	Mower not leveled. Blade dull. Grass too high or gone to seed. Drive belt slipping. Mower not adjusted properly. Engine speed too low.	Level mower (Section 5). Sharpen blade. Use sickle. Tighten belt by adjusting mower clutch lever (Section 5). Adjust (Section 5). Run at 3/4 to full throttle.
Vibrations	Arbor shaft or tube (or both) bent. Blade unbalanced. Drive pulley damaged or misaligned	Straighten or replace. Replace blade. Replace damaged pulley. Realign as required.

PROBLEM	PROBABLE CAUSE	REMEDY
Excessive play in steering.	Loose capscrews or worn bushings.	Tighten attaching hardware. Install kit 103326, Steering Mechanism (Section 5).
Loss of REVERSE drive power.	Drive linkage out of adjustment.	Refer to Section 5-6.

## SECTION 5. ADJUSTMENTS

### NOTE

If vehicle is placed on end for over a 2 hour period, the battery must be removed and the fuel tank drained.

### 5-1 CUTTING HEIGHT ADJUSTMENT

A. Raise or lower entire mower by twisting height adjustment handle (Figure 5-1) until front of blade is at desired cutting height. Clockwise to raise blade and counter-clockwise to lower.

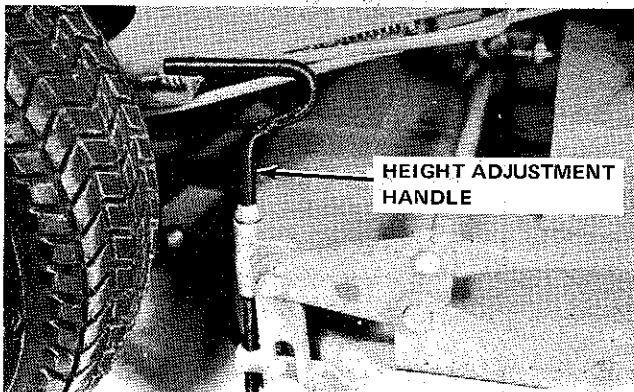

Figure 5-1. Cutting Height Adjustment

B. Most lawns should be mowed to keep the height of the grass approximately 2-inches high. Under dry conditions, it should be allowed to grow higher. To keep a green lawn, NEVER mow more than one-third off the height of the grass or a maximum of 1-inch in one mowing. For extremely tall grass, set the cutting height at MAXIMUM for the first mowing, then reset to the desired height and mow again.

C. The 30-inch mower is designed to cut grass at a height of 1-1/2 to 3-1/2-inches. Best results are obtained by cutting often and not too short. Allow the grass to grow to 3-inches then cut off only the top 1-inch.

### 5-2 MOWER CLUTCH LEVER

### NOTE

Adjustment of mower clutch lever is to be made after mower attached to vehicle.

A. When mower clutch lever is engaged (lever down), there should be approximately 3/4-inch clearance between clutch rod set collar and upper leg of rod bracket (Figure 5-2). If adjustment is necessary, loosen collar setscrew, and adjust accordingly

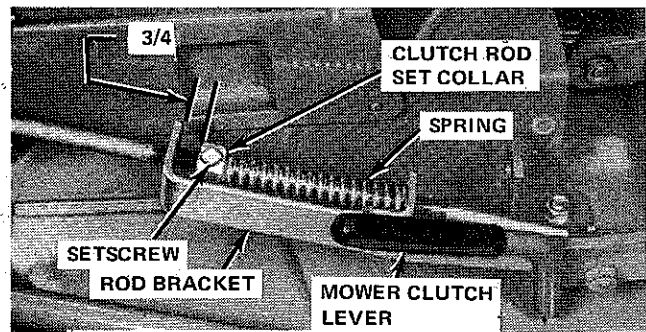

Figure 5-2. Mower Clutch Lever Adjustment

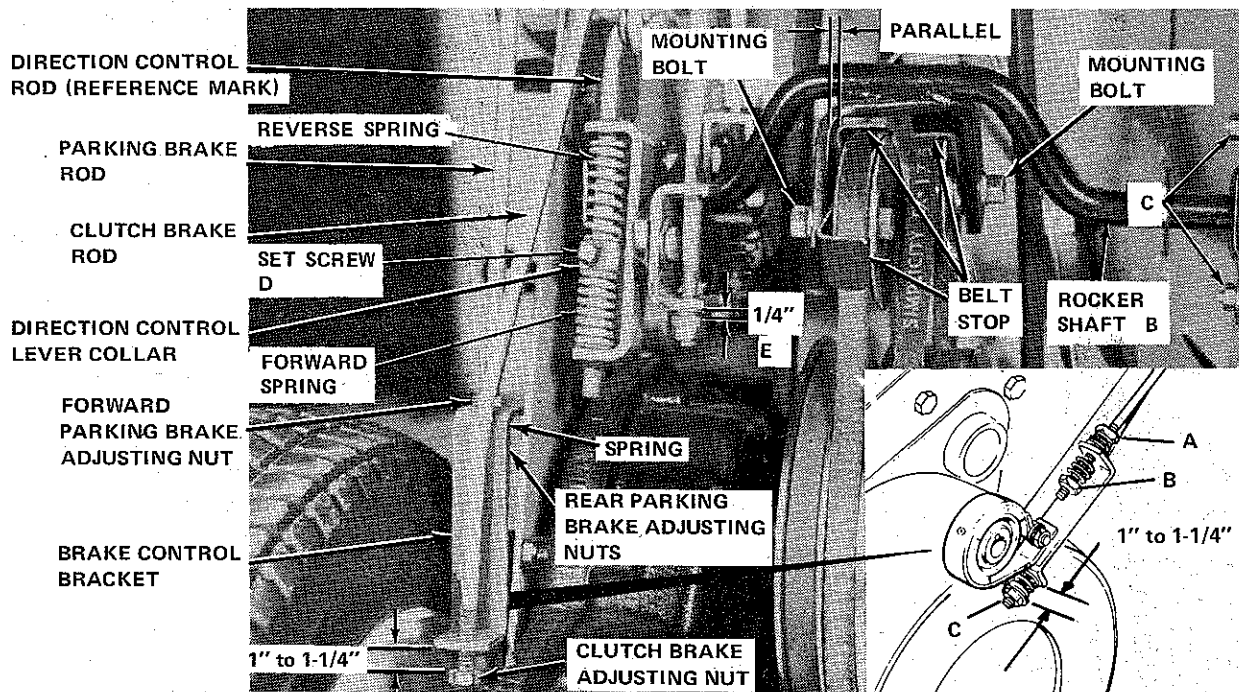
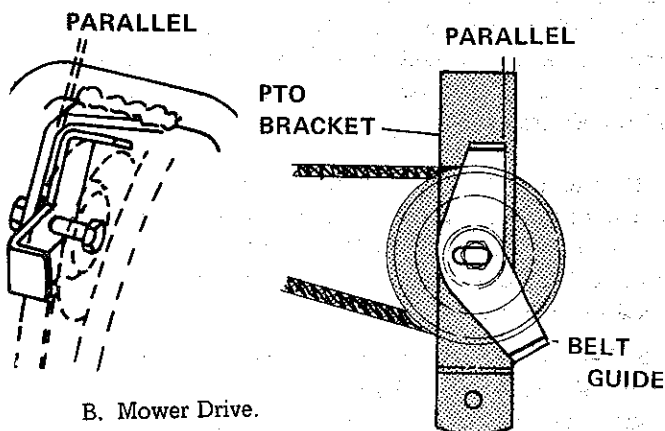

Figure 5-4. Brake and Direction Control Lever Adjustments

### 5-3 BELT STOPS

A. Forward and Reverse Idler.

Belt guides should be installed in such a fashion that the indicated edges of the guide and mounting bracket are parallel. Refer to illustration and figure 5-4.



B. Mower Drive.

Belt guides should be installed in such a fashion that the indicated edges of the guide and mounting bracket are parallel. Refer to illustration and figure 6-11.

C. Check to insure that the belt guide (See Figure 6-11) is all the way to the rear. (The belt guide is slotted for ease of belt removal, and when installed on the unit it should be pushed all the way to the rear of the tractor). The guide should be checked to insure the straight edge of the guide is parallel to the PTO bracket.

### 5-4 BRAKING

#### NOTE

Clutching and braking functions are made si-

multaneously as the clutch pedal, on the right front side of the vehicle is depressed.

A. The clutch brake rod (Figure 5-4) moves forward, as the pedal is depressed, and engages a clutch brake control bracket, which pulls upon a brake band and activates the brake. The distance from a clutch brake adjusting nut at the end of the clutch brake rod to the bracket allows for free clutch pedal travel. This adjustment should tighten brake band on drum when clutch pedal is depressed two-thirds of its total travel. If band does not tighten sufficiently, readjust adjusting nut accordingly.

1. Turn the nut (A), until it is to the end of the threaded portion of the rod.

2. Engage the parking brake lever and tighten the nut (B), until the spring is collapsed.

3. With the parking brake lever engaged, adjust the nut (C), to give 1" to 1-1/4" between the flat washer and brake band frame.

B. The opposite end of the brake control bracket is secured to a parking brake rod (Figure 5-4) that is controlled by a parking brake lever on the right side of the vehicle, below the operator's seat. When the brake lever is pushed downward, the rod and control bracket move forward, tightening the brake band. The parking brake adjusting nuts must be adjusted on the brake control bracket so that the spring is compressed solid when the brake lever is engaged.

## 5-5 CLUTCHING OPERATION

A. Clutching occurs whenever belt tension is released on the idler belts.

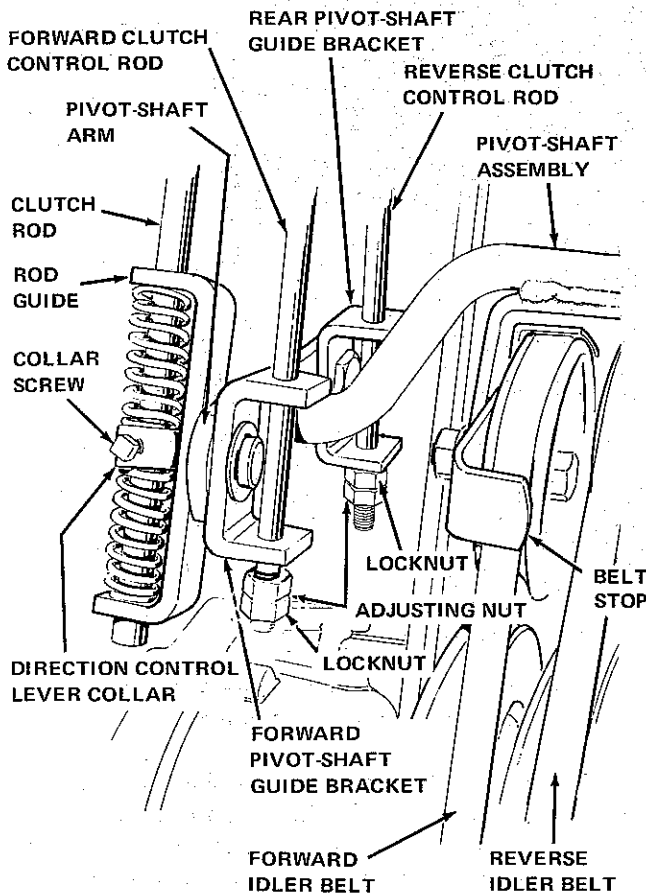

Figure 5-5. Direction Control Lever Neutral, Clutch Pedal Relaxed

Tension is made when the pivot-shaft arm is pivoted in either a forward or reverse direction by the direction control lever on the right side of the vehicle below the operator's seat. The pivoting compresses a control rod spring on an adjusting nut on either the forward or reverse clutch control rod and releases the rod spring of the remaining control rod.

B. Belt stop contact is broken when either the direction control lever is placed in NEUTRAL or the clutch-brake pedal is depressed. Clutch-brake pedal depression moves the branched clutch control rods forward. The forward mo-

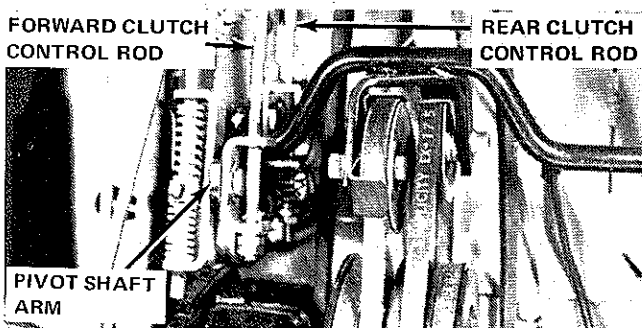

Figure 5-6. Direction Control Lever Forward, Clutch Pedal Depressed

tion pivots the pivot-shaft arm in the direction of the relaxed control rod spring (Figure 5-6). The pivot-shaft arm is then in the NEUTRAL position and there is no belt stop contact.

## 5-6 CLUTCHING ADJUSTMENTS

The following procedure is to be followed to obtain sufficient forward and reverse idler belt tension. The procedure should be as follows:

A. Item D, loosen the set screw on the set collar so the set collar is free to move. If there has been any indication of loss of reverse in the unit, at this time completely disassemble the spring/rod guide assembly and substitute the 177365 spring provided in the 103326 kit in place of the existing reverse spring (this is the top spring, if the unit is sitting upright) before proceeding with the following adjustments.

B. Applying approximately 5 lbs. of pressure, rotate the rocker shaft as far forward as possible (away from you) and place a reference mark on the rod as indicated. Noting the reference mark, rotate the rocker shaft, using approximately 5 lbs. of pressure, to the full reverse position (out towards you). There should be  $11/16''$  of travel between the two positions.

C. Item C. If this dimension is not obtained, loosen the four capscrews which hold the rocker shaft in place and adjust the rocker shaft up or down as necessary to obtain the  $11/16''$  dimension (lower the shaft towards the rear of the tractor for a larger dimension and vice versa for a smaller). Once the  $11/16''$  is obtained, secure the four capscrews using 15 ft. lbs. of torque.

D. Item D. Again rotate the rocker shaft front to back and using your reference mark, determine the half way position on the rod. This should be  $11/32''$  from one extreme position, front or back. Once the rod is in the mid-way position, tighten the set screw on the set collar.

E. Item E. Place the shuttle control lever in the full forward position, and pull the rocker shaft towards you. Now adjust the two jam nuts to give  $1/4''$  clearance between the rod guide and the first jam nut. Repeat the process for reverse; handle in reverse, push on the rocker shaft, the jam nuts and rod guide for reverse is the second assembly located directly behind the forward assembly.

F. Item F. Make sure the inside edge of the belt finger is parallel to the outer edge of the rocker shaft assembly. This holds true for both belt fingers.

## 5-7 TRANSMISSION DRIVE BELT

Turn outer adjusting nut (Figure 5-7) so that the spring distance between the flat washer and the idler bracket is  $1-1/8''$ . Turn the elastic stop nut to the rear of the tractor

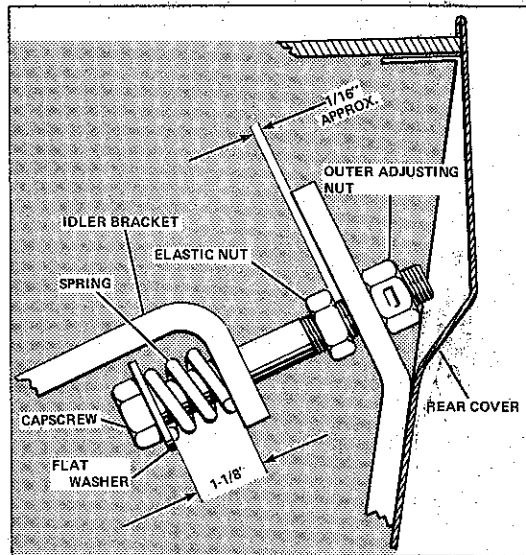

Figure 5-7. Transmission drive belt adjustment.

until it strikes the tractor frame. In some cases it may be necessary to cut 1/4" from the rear of the capscrew after making the preceding adjustment in order to properly close the rear door on the unit. This adjustment should be rechecked after the unit is run.

## 5-8 STEERING MECHANISM

### NOTE

If excess play in steering mechanism is noted install kit 103326 as follows:

1. Remove the mower and stand the tractor in an upright position for easy access in making the following adjustment. (Be sure the gas tank is less than 1/2" full before tipping the tractor upright).

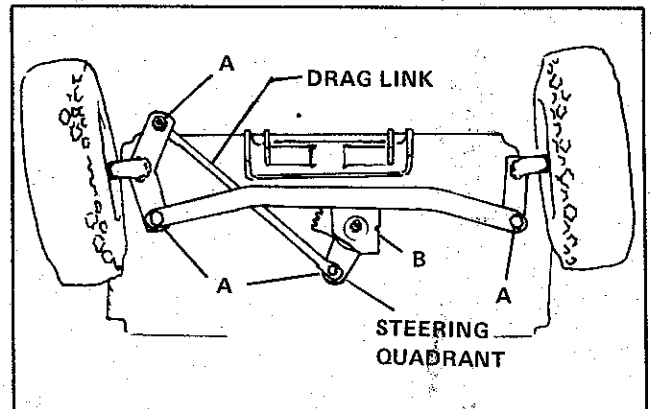

Figure 5-8. Steering Adjustment Points

2. Check to insure the steering wheel is securely attached to the steering post.

3. Check the three capscrews at the bottom of the steering column for tightness. (Torque to 20 ft. lbs.).

4. See Figure 5-8, Item A. Remove the drag link from the unit, and remove the two brass bushings from the drag link. Install the two 154177 bushings supplied in the 103326 kit in place of the brass bushings removed. Re-assemble the drag link assembly and torque all items indicated with an "A" to 30 ft. lbs.

5. See Figure 5-8, Item B. Loosen the steering quadrant from the tractor. Remove the two washers, lock screw and flange nut while doing this. Now reinstall the quadrant using the 178489 washer, 178490 washer, 715182 lock screw and 718073 flange nut supplied in the 103326 kit in place of the items previously removed. Torque this assembly to 60 ft. lbs.

## SECTION 6. MAINTENANCE

### 6-1 MAINTENANCE

#### A. Crankcase Oil.

1. Check the crankcase oil level (Figure 3-4) when fuel is added or every five operating hours. Change oil every 20 operating hours using 2-1/4 pints of SD/CC, MS, MS/DG, or MS/DM 10W-30 grade motor oil.

### NOTE

Pay attention to "Service Designation" stamped on the top of each can of oil you intend using in your engine. Use oil labeled MS (Motor Severe), but do not use ML or MM labels as they do not contain sufficient additives for proper protection. Labels DL and DM may be used

also; however, DO NOT use a DS label oil as it is too severe in detergent quality for this application. Be sure to use a premium grade oil.

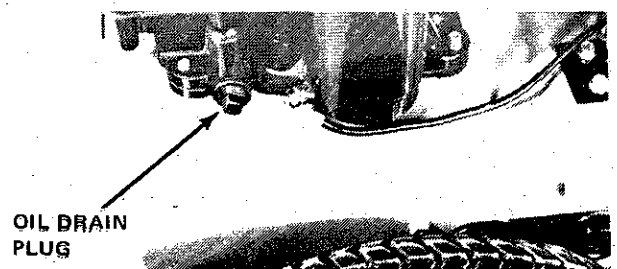

Figure 6-1. Oil Drain Plug



2. Crankcase oil should be drained when engine is warm. Place suitable container under oil drain plug and remove plug (Figure 6-1). Allow oil to drain completely, then replace drain plug. Fill crankcase through cap and gauge hole (Figure 3-4).

**B. Grease and oiling points.**

1. Grease wheel fittings, control lever and quadrant, and frame pivot washers every 10 operating hours with lithium-based No. 2 automotive grease. Remove all

dirt, grit and paint from fittings before application. Apply Blend No. 4E grease to brake and clutch rod guide. Make sure grease is distributed internally into rod guide.

2. Apply light engine oil every 10 operating hours to all points specified in Figures 6-2, 6-3, and 6-4 except tie rod and draglink pivots. Apply 10W-30 or heavier motor oil to tie rod and draglink pivots (Figure 6-4).

3. Use the following illustrations as a guide to greasing and oiling.

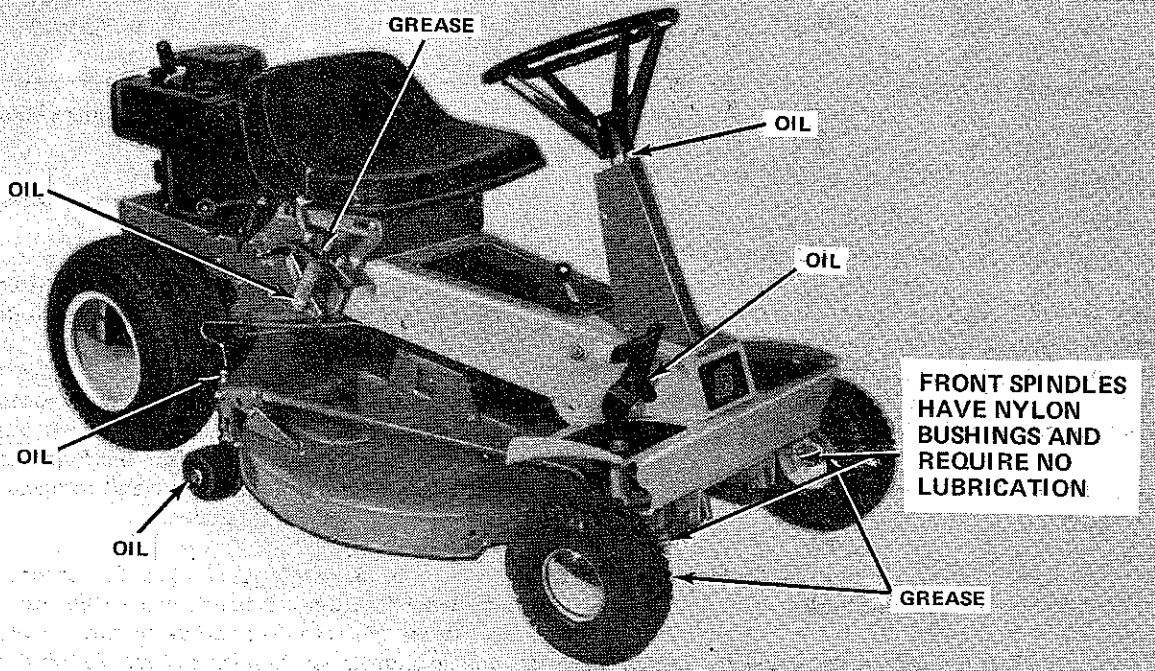

**Figure 6-2. Right Side Lubrication Points**

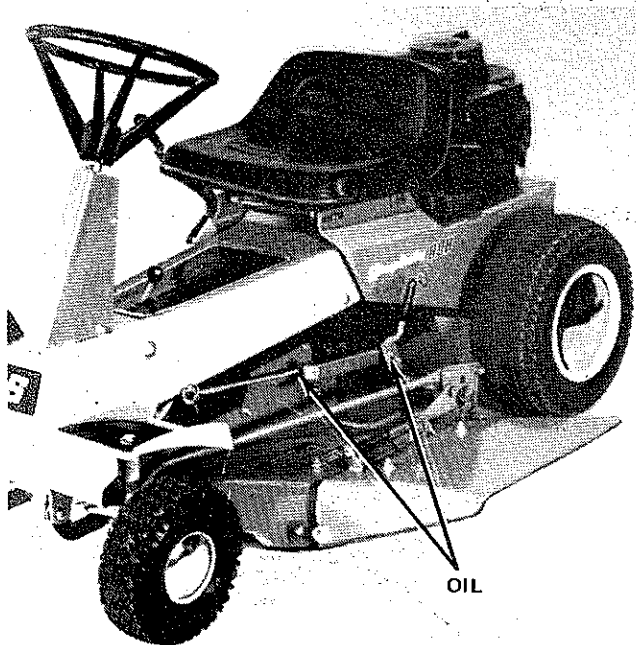

**Figure 6-3. Left Side Lubrication Points**

**C. Transmission Oil.**

1. Check transmission oil every 10 hours of operation. Transmission oil can be checked with the vehicle on all four wheels or standing upright on its rear.

To check level when vehicle on all four wheels, remove fill and drain plug (Figure 6-12). To check level when vehicle upright, remove fill and drain plug (Figure 6-4).

**CAUTION**

If vehicle placed in upright position longer than two hours, remove battery from vehicle to avoid leakage.

2. Operate vehicle for 1/2 hour to warm transmission oil before draining. Remove lower plug, allowing oil to drain into a suitable container.

3. To add transmission fluid, install lower plug and add 2-1/2 pints of Amerec 90 gear oil through top plug opening.



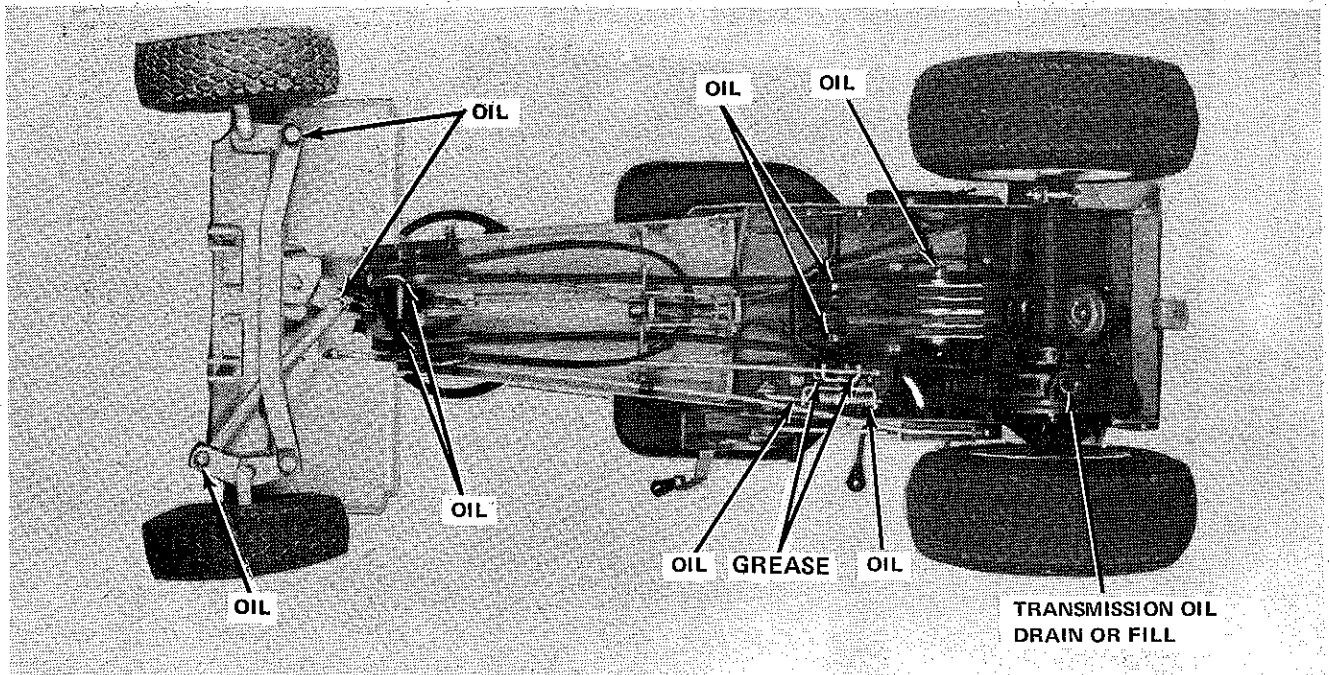

Figure 6-4. Bottom Lubrication Points

## 6-2 ENGINE COMPONENT CLEANING

### A. Air Cleaner.

1. Service air cleaner every 20 operating hours or, if operating under extremely dusty conditions, 5-10 operating hours.

2. Remove air cleaner cover and wash foam air cleaner element in gasoline, squeezing several times. Allow it to dry thoroughly and saturate it with engine oil. Squeeze several times to remove excess oil and reinstall.

### B. Spark Plug.

Clean and regap spark plug every 100 operating hours. Do not clean plug by sandblasting as this process leaves a residue of grit in the plug, which can cause engine damage. Clean the plug with solvents, scraping or using a wire brush. Gap to 0.030 of an inch. Discard plug if cannot clean adequately or if plug is old and worn.

### NOTE

Briggs and Stratton Corp. will not honor the warranty on any engine damaged by grit from a sandblasted spark plug.

### C. Cooling Fins.

Clean all clippings, dirt, and chaff from cooling fins on the cylinder and head to prevent damage from overheating.

## 6-3 MOWER REPAIR

### A. Removal.

1. Remove mower from unit by disengaging the mower clutch lever, and also disengaging the mower deck lift lever. (Figure 6-5).

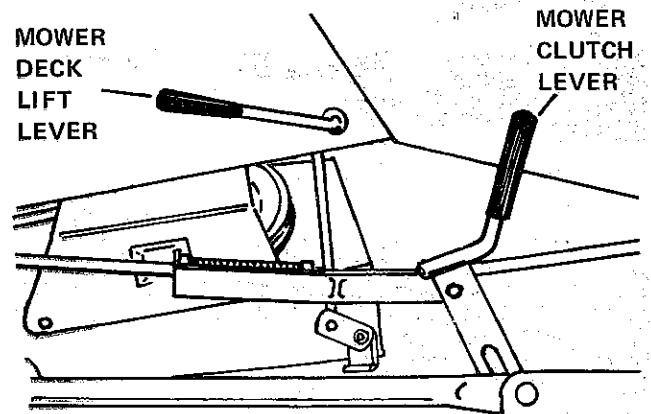

Figure 6-5 Mower Clutch Lever and Deck Lift Lever

2. Remove hairpin clip (Figure 6-6) from mower idler pulley bracket and remove adjusting rod from bracket.

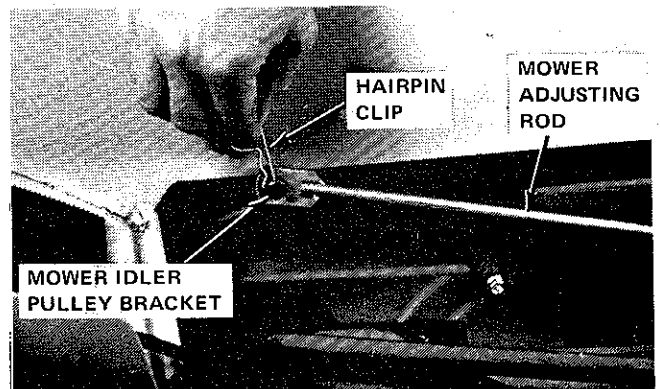

Figure 6-6. Mower Adjusting Rod Attachment

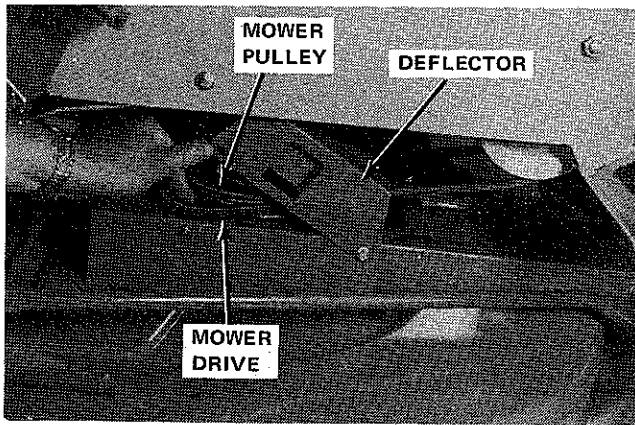

Figure 6-7. Mower Drive Belt and Pulley

3. Lifting deflector, disengage mower drive belt from mower pulley (Figure 6-7). To separate belt from pulley, it may be necessary to move entire mower forward slightly.

4. Supporting front end of mower, remove two hairpin clips and pins attaching front of mower to vehicle. (Figure 6-8). Slowly lower mower and slide it out from under vehicle.

5. Place mower end of drive belt in bracket under frame. (Figure 6-4).

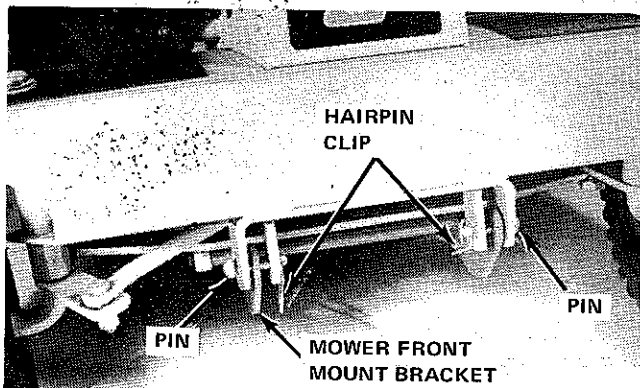

Figure 6-8. Mower Front Mount Brackets

#### B. Cleaning and Inspection.

1. Clean all grass clippings and material from housing. Clean blade and arbor.

2. Rotate blade by hand to see if ends are level with each other. Inspect blade for nicks or grooves.

3. Inspect drive belt for wear or age.

#### C. Repair.

1. Remove small nicks from blade with file or stone. Do not file excessively or blade will require rebalancing. Deep nicks in blade cutting edge will require

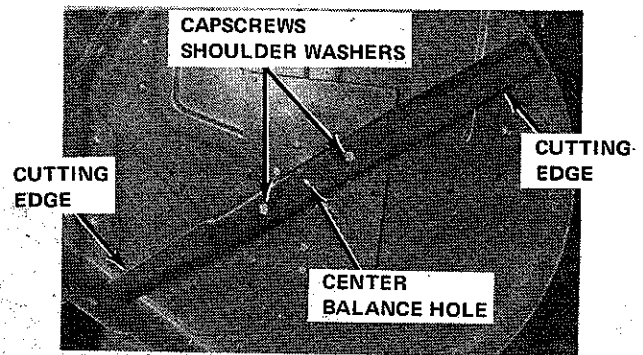

Figure 6-9. Mower Blade

grinding and subsequent rebalancing (See Blade Replacement for blade removal procedures).

2. Securely tighten all mower and guard attaching parts.

#### D. Blade Replacement.

1. Using several layers of folded cloth or a leather glove hold one end of blade while removing both capscrews and shoulder washers (Figure 6-9) attaching blade to arbor.

2. To sharpen blade, clamp it in a vise and use a 10 inch file along original bevel. File to a razor edge.

3. To balance blade, insert a knife blade or small rod through center hole (Figure 6-9) and observe if both ends balance evenly. Refile heavy side, if required.

#### WARNING

**ALWAYS HANDLE BLADE WITH CARE TO AVOID INJURY.**

4. Using cloth or glove, install blade on mower, cutting edge upward. Tighten blade mounting capscrews to 37-47 ft. lbs. torque.

5. Slowly rotate blade by hand to see if it clears housing and tips are running true.

#### E. Mower Drive Belt Replacement.

Refer to par. 6-4 for mower drive belt removal and installation, if required.

#### F. Installation.

1. Move mower under vehicle and, supporting front end of mower, secure it to front end brackets with two pins and hairpin clips (Figure 6-8).

2. Lifting deflector, reinstall mower drive belt on mower pulley. (Figure 6-7). Mower clutch lever must be in disengaged position or to the rear and up (Figure 6-5).

3. Secure adjusting rod to mower idler pulley bracket with hairpin clip (Figure 6-6). Engage mower suspension hook.

#### G. Adjustments and Operation.

Refer to Section 3 for vehicle-mower operation and Section 5 for mower adjustments.

#### H. Arbor shaft or Sleeve damage.

If the mower is properly adjusted and in apparent good condition, but seems to require excess engine power, it may be that the arbor shaft or sleeve has been damaged by hitting an obstruction. Check the blade drive system. The rotor spindle (or spindles) should turn with 1 to 2 lbs. pull on the blade with the drive belt removed. If the pull pressure exceeds 2 lbs., the unit is robbing power from the engine. Tight bearings, a bent arbor shaft or spindle housing can be repaired or replaced by your Simplicity dealer. Arbor nut (see mower housing exploded view) must be torqued to 140 foot-pounds.

### 6-4 BELT REPLACEMENT

#### NOTE

Refer to Figure 6-10 for location of pulleys and belts.

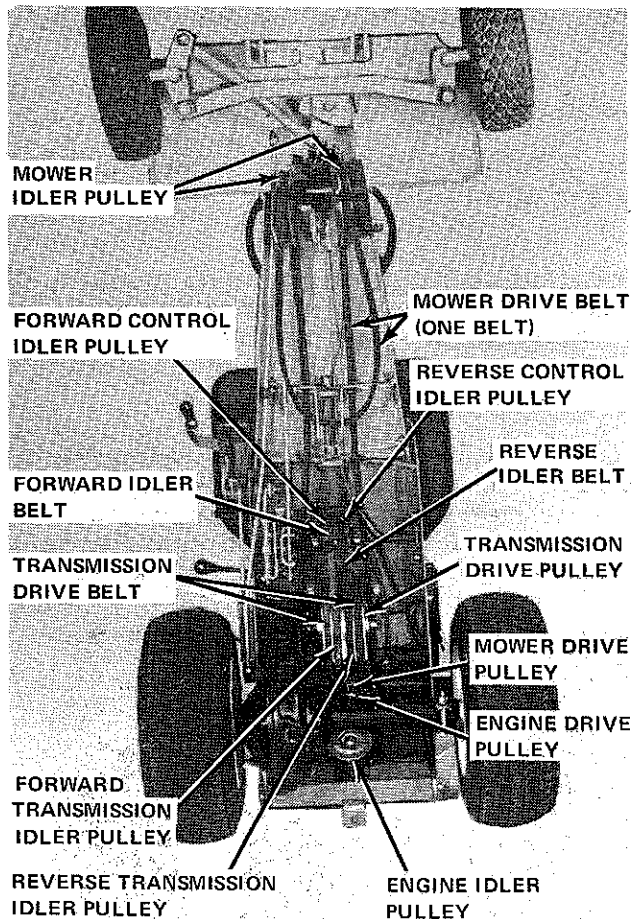

Figure 6-10. Belt and Pulley Location

#### A. Mower Drive Belt.

1. Remove mower (Par. 6-3).

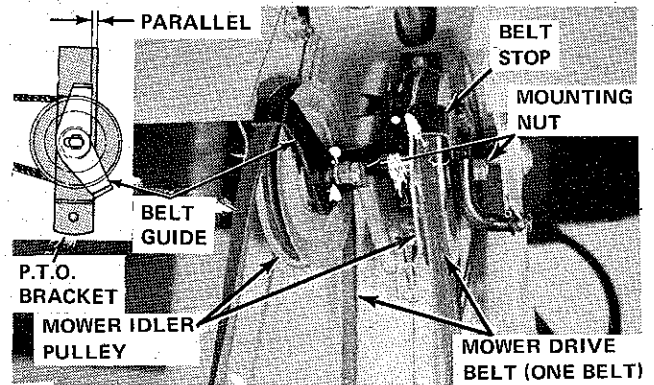

Figure 6-11. Mower Clutch Assembly

2. Loosen belt stop and pulley mounting nuts (Figure 6-11) and position belt stop so that stop fingers allow for belt removal. Remove mower drive belt from mower idler pulleys.

3. Open battery cover at rear of vehicle. Back off the outer adjusting nut (Figure 6-12) far enough that the tension on the engine drive belt is reduced to the point where the belt may be removed from the engine crankshaft pulley. It may be necessary to completely remove the outer adjusting nut to accomplish this.

4. Install new mower drive belt in reverse order of removal. Belt stops must be positioned as outlined in Section 5-3 item B. Adjust mower clutch lever as instructed in Section 5.

#### B. Transmission Drive Belt.

1. Open battery cover at rear of vehicle (Figure 6-12).

2. Push engine idler pulley (Figure 6-12) in against spring until engine drive belt can be slid from pulley. If spring does not allow sufficient compression to allow belt removal, loosen outer adjusting nut a few turns.

3. Disengage engine drive belt from engine drive pulley (Figure 6-10) and remove from battery cover opening.

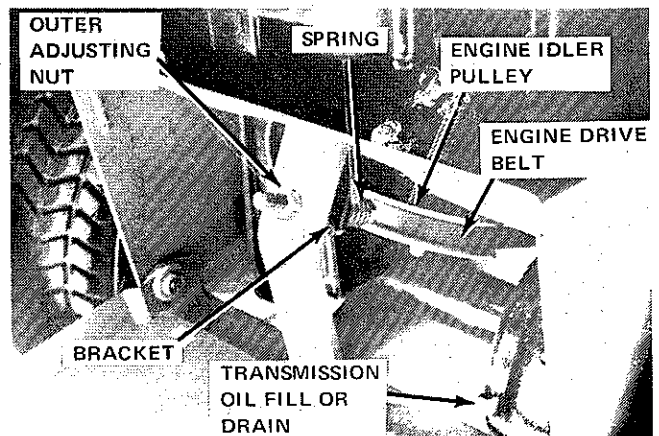

Figure 6-12. Engine Idler Pulley and Drive Belt

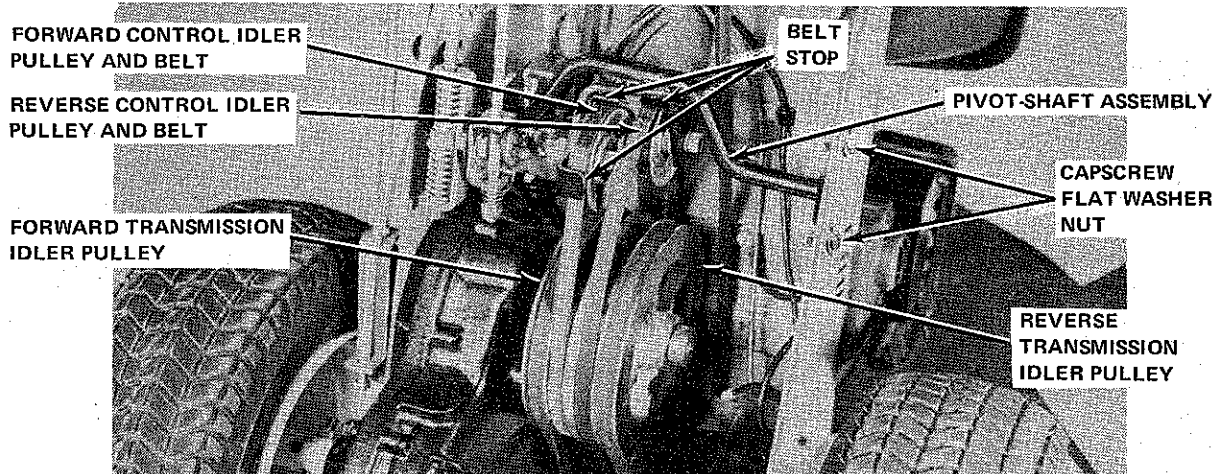

Figure 6-13. Forward and Reverse Idler Belts and Pulleys

**NOTE**

Engine drive belt is only one belt and it engages transmission drive pulleys in opposite directions. The engine drive pulley is smaller than its neighboring mower drive pulley.

4. Working through battery cover opening, install new transmission drive belt (Figure 6-10) on engine drive pulley. Carefully work belt over outside transmission drive pulleys and depress engine idler pulley (Figure 6-12) enough to slip new engine drive belt in place. Adjust drive belt as instructed in paragraph 5-7 of this manual.

**C. Forward and Reverse Idler Belts.**

1. Remove transmission drive belt as previously outlined.
2. Loosen belt stop mounting bolts and slide them forward enough to slide either or both idler belts from either or both control idler pulleys.
3. Remove both idler belts from their respective transmission idler pulleys.
4. Install new idler belts in reverse order of removal. Belt stops must be positioned as outlined in section 5-3 item A. Pivot-shaft assembly must be secured sufficiently forward to allow controls to activate either forward or reverse belt. Refer to Section 5 for proper belt tension.

**6-5 BATTERY REPLACEMENT**

**NOTE**

A hydrometer test of battery solution should be made monthly or more often in warmer weather. If specific gravity tests 1.225 or less, the battery should be recharged. At the same time the solution level should be checked and distilled water added to retain level as designated on battery. Always add distilled water before recharging. Use charger receptacle next to ignition switch. If battery is to be charged off the vehicle, do not exceed 1.3 amperes charging rate;

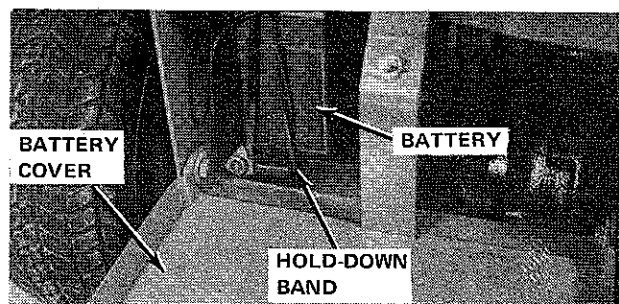

Figure 6-14. Battery Installation

1. Open battery cover in rear of vehicle and remove hold-down band from battery (Figure 6-14).
2. Slide battery from support and remove battery cables from terminals. (Figure 6-15).

**WARNING**

**TO AVOID ACCIDENTAL SPARKS: DISCONNECT NEGATIVE (-) GROUND CABLE FIRST AND CONNECT IT TO BATTERY LAST.**

3. Place battery in clean, level location.
4. Install new or recharged battery in reverse order of removal. Position hold-down band securely around battery. If the overflow drain hose is pinched under the battery during installation, move the hose clamp to the right front corner of the battery. Hose must not be blocked and be 1/8-inch from bottom of battery.

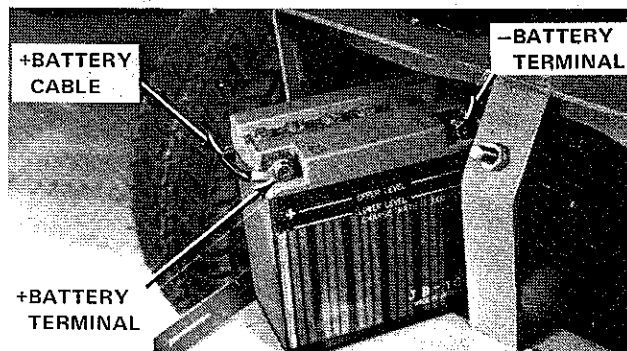

Figure 6-15. Battery Cables and Terminals

## SECTION 7. STORAGE

### 7-1 OFF-SEASON STORAGE

A. Drain the fuel tank completely by running the engine until it stops. If desired, fuel can be stored in containers or in the tank by using STA-BIL brand gasoline stabilizer, available at your Simplicity dealer. Add a can capful to the fuel in the tank or follow the directions on the can for containers of other capacity. This additive prevents formation of gum and varnish for up to one year, providing easier starting and a clean fuel system.

B. Drain and refill crankcase while engine is warm. (See Section 6, Maintenance).

C. Remove spark plug, pour 1 oz. 10W-30 oil into cylinder through plug hole. Crank engine a few times to distribute oil. Reinstall plug.

D. Clean dirt and chaff from cylinder head fins and engine housing.

E. Apply grease to all fittings and light engine oil to all points listed in Section 6, Maintenance.

F. Block the machine up off the wheels to relieve weight and keep tires off a damp floor. Protect the tires from prolonged exposure to direct sunlight.

G. Store the machine in a dry place indoors.

### 7-2 STARTING AFTER STORAGE

A. Remove the spark plug and wipe it dry. Crank the engine a few times to blow the excess oil out the plug hole, then reinstall the plug.

B. Fill the fuel tank completely with fresh "Regular" gasoline.

C. Service the air cleaner. (See Section 6, Maintenance.)

D. Check the crankcase oil level and replenish if necessary (Section 6, Maintenance).

E. Start the engine and let it run slowly. DO NOT run at high speed immediately after starting. Run the machine outdoors or in a well-ventilated area.

F. Inflate the tires to proper operating pressure. The front tires should be 22-25 psi and the rear 10 psi.

## SECTION 8. ILLUSTRATED PARTS LIST

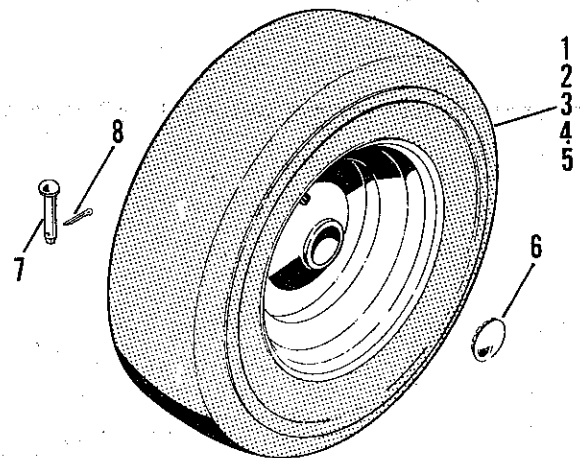
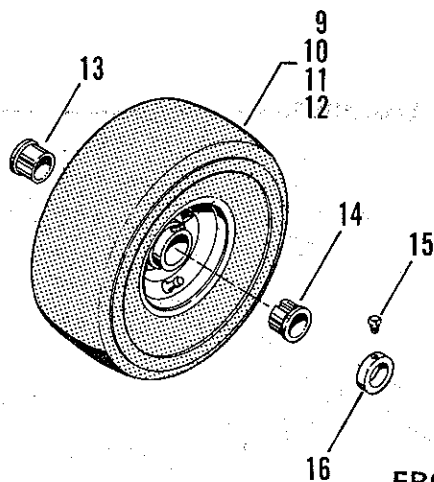

FRONT & REAR TIRES

Ref. No.	Part No.	Qty. Req.	Description
1	171851	2	Rear Wheel & Tire Assy. (Incl. Ref. Nos. 2 thru 5)
2	171850	2	Wheel Assembly
3	159156	2	Tire - Tubeless
4	153038	2	Tube
5	171270	2	Valve Stem-Cap
6	158433	2	Plug Button
7	118053	2	Pin
8	722009	2	Cotter Pin, 1/8" x 3/4" lg.

Ref. No.	Part No.	Qty. Req.	Description
9	163106	2	Front Wheel & Tire Assy. (Incl. Ref. Nos. 10 thru 14)
10	163107	2	Wheel
11	163108	2	Tire
12	163109	2	Tube
13	163110	4	Bearing
14	163111	4	Bearing Relief
15	713503	2	Set Screw, 5/16" - 18 x 5/16" lg.
16	8021010	2	Set Collar





**MFG. NO. 1000 Electric Start**

Ref. No.	Part No.	Qty. Req.	Description
1	176623	1	Support Assy. (Battery)
2	718009	3	Speed Nut
3	714006	3	Self-Tapping Screw 10 x 1/2
4	106786	1	Clamp
5	177981	1	Battery Assy. Cable (To Solenoid)
6	176975	1	Negative Battery Cable Assy. (To Ground)
7	177390	1	Battery and Clip Assy.
8	174648	1	Battery
9	176912	1	Wire Clip
10	177982	1	Solenoid Cable Assy. (To Starter)
11	177983	1	Ignition Wire Assy. (Switch to Solenoid)
12	177985	1	Trans. Wire Assy. (Switch to Ignition Switch)
13	177984	1	Wire Assy. (PTO Switch to Solenoid)
14	172410	1	Fuse 7-1/2 Amp.
15	178172	1	Wire Assy.
16	178173	1	Wire Assy.
17	178171	1	Resistor
18*	715189	2	Screw, Thread Forming
19	122216	1	Solenoid
20	178444	1	Wire

\* Not Shown

**MFG. NO. 998 Manual Start**

Ref. No.	Part No.	Qty. Req.	Description
1	177163	1	Switch
2	177164	1	Adaptor
3	122203	1	Key & Ring Assy.
4	178448	1	Support Switch
5	715124	2	Screw, Thread Forming
6	178447	1	Ignition Interlock
7	715124	1	Screw, Thread Forming
8	176834	1	Wire
9	178444	1	Wire
10	154247	1	Clamp
11	715124	1	Screw, Thread Forming
12	177522	2	Safety Switch
13	718067	3	Nut, Pal
14	176883	2	Grommet
15	172176	2	Grommet
16	176912	2	Clip, Wire

**WIRING DIAGRAM FOR MANUAL START (991000)**

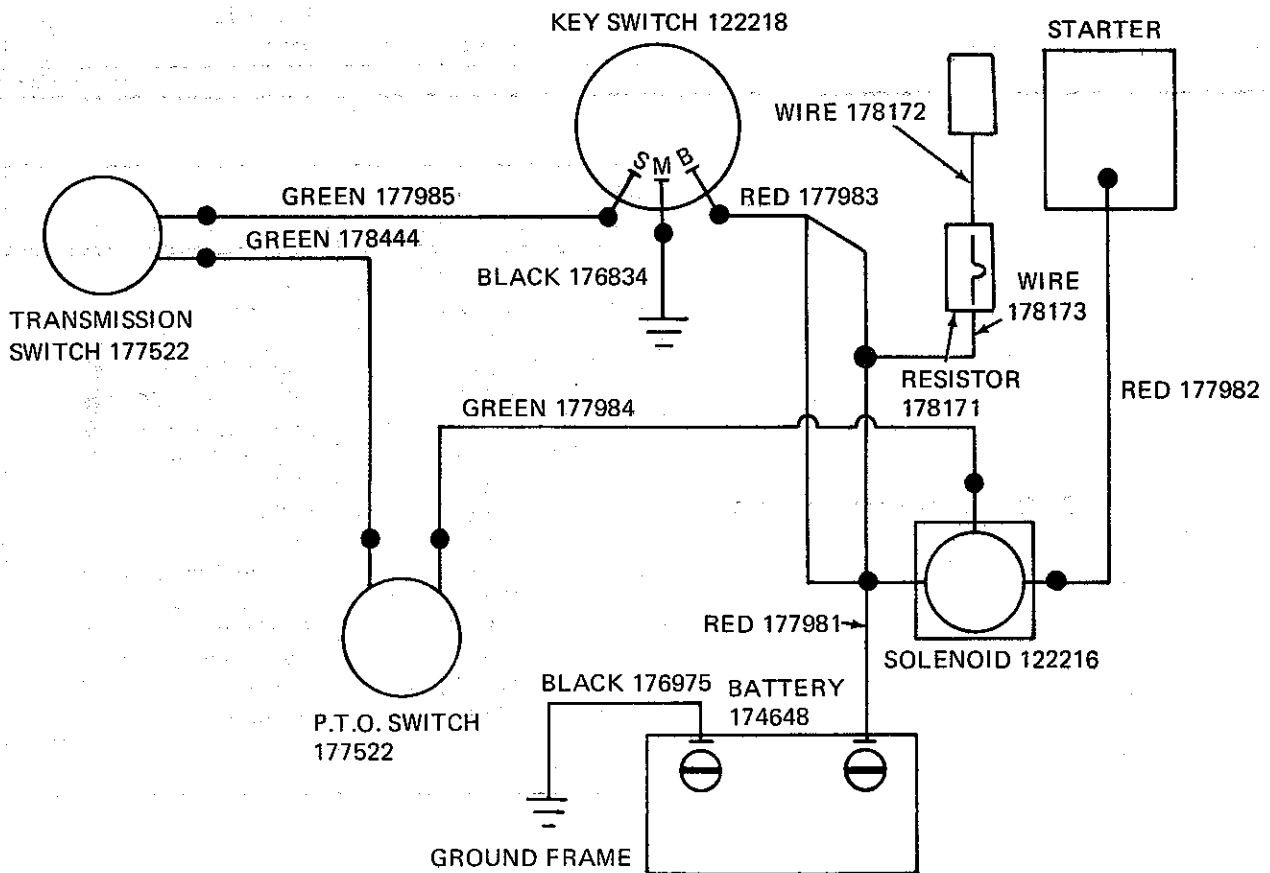
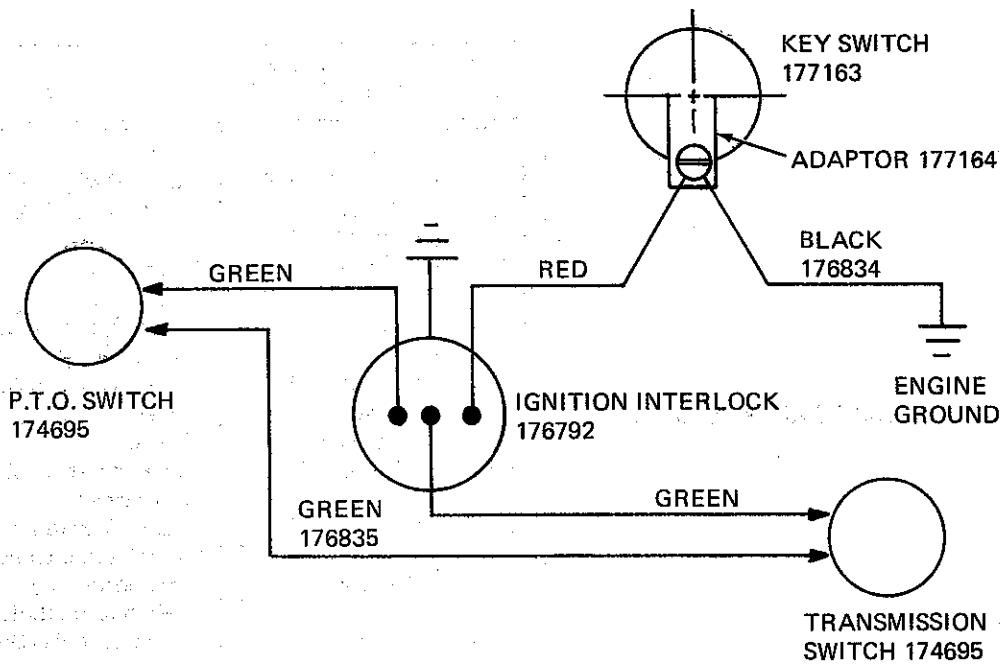

**WIRING DIAGRAM FOR ELECTRIC START (990998)**



# DECALS

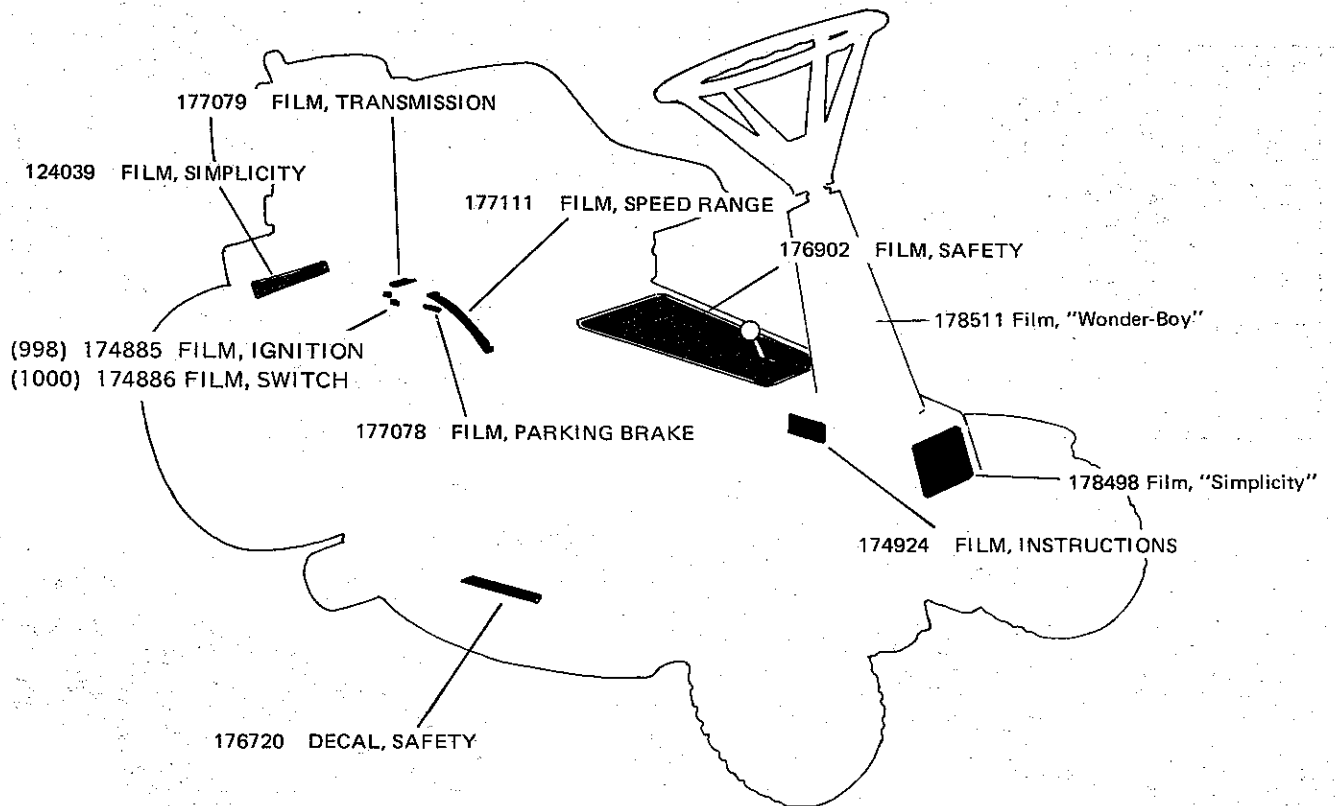
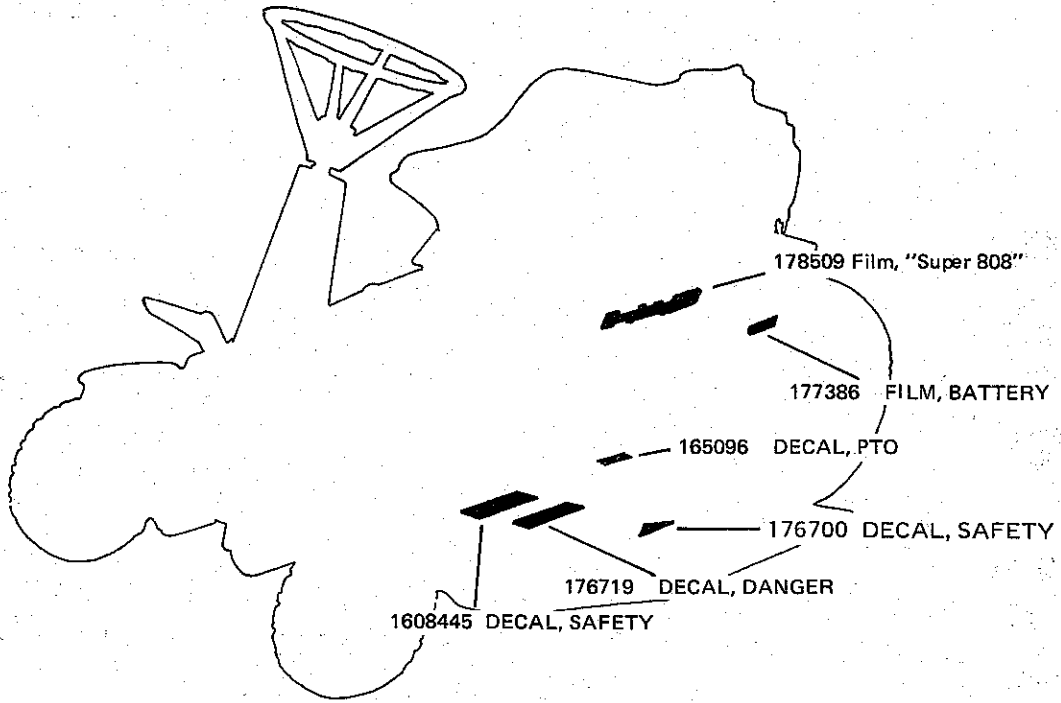

# CLUTCH & BRAKE

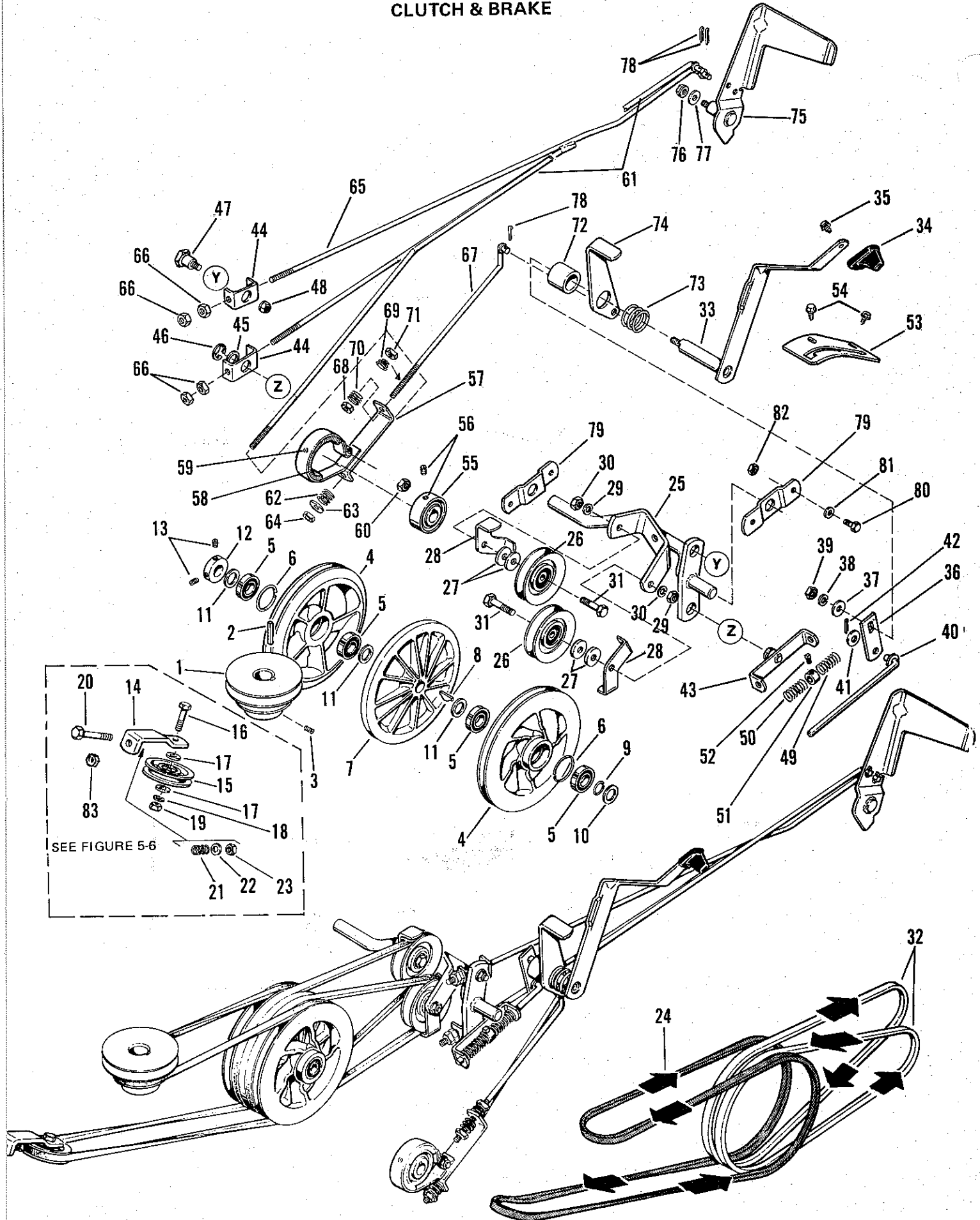

## CLUTCH & BRAKE

Ref. No.	Part No.	Qty. Req.	Description
1	175365	1	Engine Pulley
2	159129	1	Key
3	713503	1	Set Screw, 5/16"-18 x 5/16" lg.
4 *	176502	2	Outer Pulley Assembly (Includes 2 Ref. No. 5 & 1 Ref. No. 6)
5	175734	4	Bearing
6	108051	2	Retaining Ring
7	175739	1	Center Disc Clutch
8	157332	1	Key
9	8061048	1	Retaining Ring
10	175271	1	Washer
11	121210	3	Washer
12	108289	1	Set Collar
13	713503	2	Set Screw, 5/16"-18x5/16"lg.
14	176493	1	Idler Bracket
15	176640	1	Idler Pulley
16	715099	1	Hex Capscrew, 3/8"-16 x 1-1/2" lg.
17	719002	2	Plain Washer, 5/16"
18	720002	1	Lock Washer, 3/8"
19	717003	1	Hex Nut, Full, 3/8"-16
20	715184	1	Hex Capscrew, 3/8"-16 x 4"lg.
21	177365	1	Spring
22	719002	1	Plain Washer, 5/16"
23	717504	1	Hex Nut, Elastic Lock 3/8"-16
24	177452	1	V-Belt
25	175950	1	Pivot Bracket
26	174561	2	Idler Pulley
27	157424	4	Special Washer
28	174402	2	Belt Guide
29	720002	2	Lock Washer
30	717003	2	Hex Nut, Full, 3/8"-16
31	715099	2	Hex Capscrew, 3/8"-16 x 1-1/2" lg.
32	175361	1	Matched Belts
33	175945	1	Control Lever Assembly
34	171165	1	Knob
35	714012	1	Thread Forming Screw, 1/4"-20 x 7/8" lg.
36	176899	1	Link
37	719001	1	Plain Washer, 3/8"
38	720002	1	Lock Washer, 3/8"
39	717003	1	Hex Nut, Full, 3/8"-16
40	175947	1	Clutch Rod

Ref. No.	Part No.	Qty. Req.	Description
41	719001	1	Plain Washer, 3/8"
42	722006	1	Cotter Pin, 1/8" x 1" lg.
43	176796	1	Rod Guide Assembly
44	176797	2	Rod Guide
45	101025	1	Washer
46	118240	1	Retaining Ring
47	161166	1	Shoulder Bolt
48	718064	1	Flange Lock Nut, 3/8"-26
49	177365	1	Spring
50	177365	1	Spring
51	105201	1	Set Collar
52	713001	1	Set Screw, 1/4"-20x3/8"lg.
53	176014	1	Quadrant
54	715083	2	Swageform Screw, 5/16"-18 x 1/2" lg.
55	165067	1	Brake Drum
56	713503	2	Set Screw, 5/16"-18x5/16"lg.
57	176638	1	Brake Band Assembly (Includes Ref. No. 59 & 60)
58	156136	1	Brake Lining
59	724502	3	Rivet
60	718064	1	Flange Nut, 3/8"-26
61	176669	1	Brake Rod
62	162085	1	Spring
63	719002	1	Plain Washer, 5/16"
64	717511	1	Hex Nut, Full, Lock, 5/16"-18
65	176730	1	Clutch Rod Assembly
66	717001	4	Hex Nut, Full, 3/8"-16
67	176864	1	Parking Brake Rod
68	717001	1	Hex Nut, Full, 3/8"-16
69	153010	1	Spring
70	8191047	1	Spring
71	717525	1	Hex Nut, Elastic 5/16"-18
72	176865	1	Hub
73	153093	1	Spring
74	176866	1	Lever
75	176663	1	Pedal Assembly
76	718064	1	Flange Nut, 3/8"-26
77	719001	1	Plain Washer, 3/8"
78	722001	3	Cotter Pin, 3/32"x3/4"lg.
79	176551	2	Support Pivot
80	715057	4	Hex Capscrew, 1/4"-20 x 3/4" lg.
81	719006	4	Plain Washer, 1/4"
82	718049	4	Flange Nut, 1/4"-24
83	717510	1	Hex Nut, Full, Lock 3/8-16"



IF TRANSMISSION PULLEYS (4) REMOVED, BE SURE TO COMPRESS PULLEYS ON CENTER DISC CLUTCH (7) WHEN INSTALLING BEFORE TIGHTENING SET COLLAR SET SCREW (13).

# TRANSMISSION

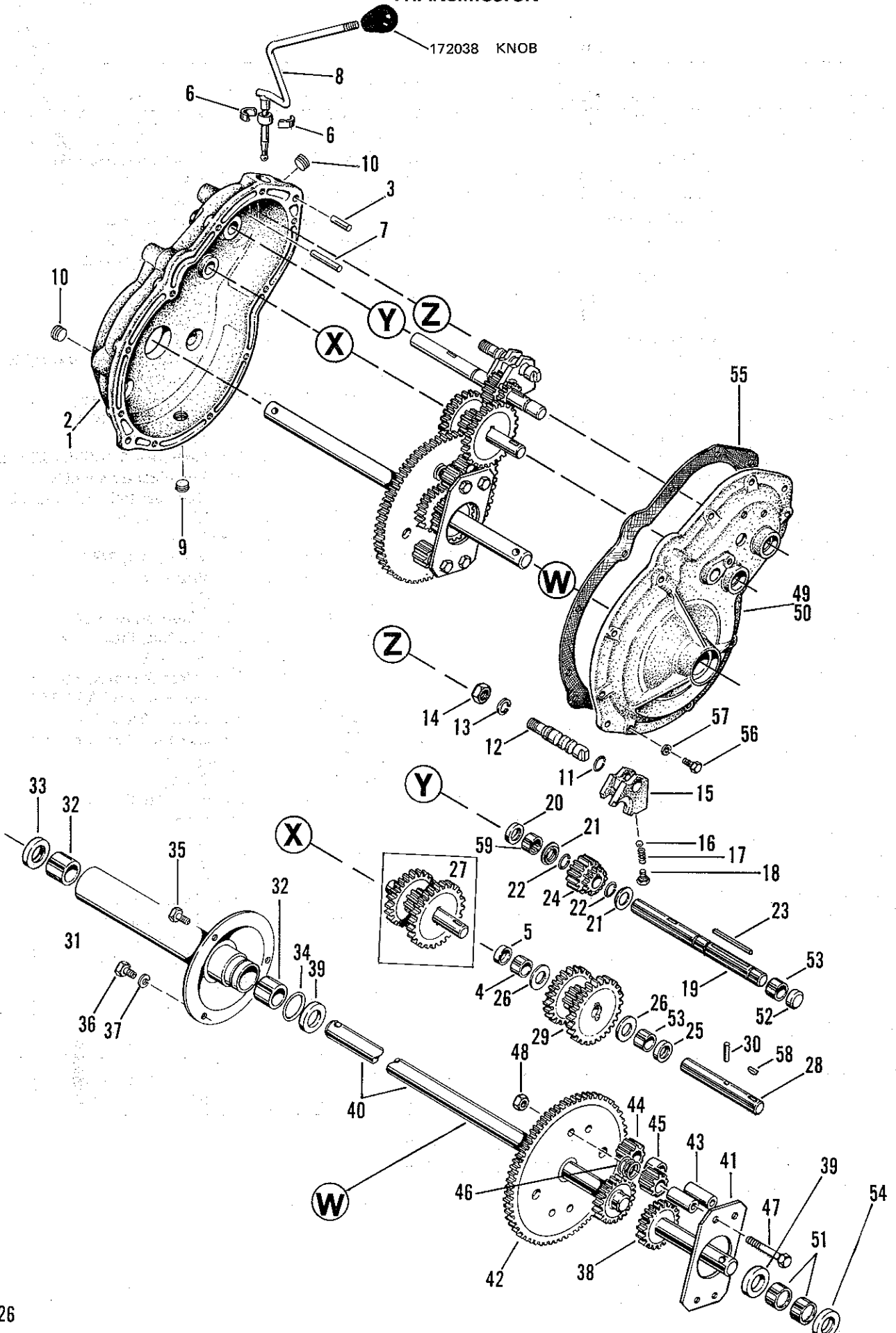

## TRANSMISSION

Ref. No.	Part No.	Qty. Req.	Description
1	175329	1	Gear Case Assy. (Incl. Ref. Nos. 2 thru 8 and 59)
2	175330	1	Gear Case
3	723007	2	Roll Pin
4	163022	1	Bushing
5	163050	1	Expansion Plug
6	101042	2	Bushing, Ball, Half
7	723025	1	Roll Pin
8	176619	1	Shift Rod Assembly
9	726003	1	Pipe Plug
10	726252	2	Pipe Plug
11	8061048	1	Retaining Ring
12	165004	1	Shift Shaft, Rev-Lo
13	720006	1	Lock Washer, 7/16"
14	717022	1	Hex Nut, Full, 7/16"
15	171364	1	Shift Fork, Hi-Lo
16	154262	1	Ball
17	171456	1	Spring
18	715133	1	Hex Capscrew, 5/16"-18 x 5/16" lg.
19	175270	1	Pulley Shaft
20	156084	1	Oil Seal
21	156085	2	Washer
22	8061048	2	Retaining Ring
23	170453	1	Key
24	156087	1	Pinion Assy., Hi-Lo
25	156084	1	Oil Seal
26	156089	2	Washer
27	165009	1	Shaft and Gear Assembly (Incl. Ref. Nos. 28-29)
28	165010	1	Brake Shaft
29	165011	1	Gear Cluster Assembly
30	156292	1	Dowel Pin

Ref. No.	Part No.	Qty. Req.	Description
31	177811	1	Axle Housing Assembly (Includes Ref. No. 32)
32	163021	2	Bushing
33	163012	1	Oil Seal
34	156099	1	Oil Seal
35	161130	1	Special Capscrew
36	705031	2	Hex Capscrew, 3/8"-16 x 7/8" lg.
37	720002	2	Lock Washer, 3/8"
38	175312	1	R. H. Axle Assembly
39	175311	2	Washer
40	175314	1	L. H. Axle Assembly
41	156002	1	Differential Plate
42	175328	1	Drive Gear Assembly
43	121083	4	Spindle
44	158579	4	Pinion
45	121084	2	Spacer
46	162085	2	Spring
47	715043	4	Hex Capscrew, 3/8"-16 x 2-1/2" lg.
48	717510	4	Hex Nut, Full, Lock 3/8"-16
49	175331	1	Gear Cover Assy. (Incl. Ref. Nos. 50 thru 53)
50	175332	1	Cover
51	163021	2	Bushing
52	163074	1	Expansion Plug
53	163022	2	Bushing
54	163012	1	Oil Seal
55	156103	1	Gasket
56	705019	10	Hex Capscrew, 5/16"-18 x 1-1/4" lg.
57	720001	10	Lock Washer, 5/16"
58	725505	1	Key, 5/32" x 5/8"
59	156072	1	Bearing

# FRONT FRAME & STEERING

**STEERING GEAR MUST BE ATTACHED TO FRAME AS ILLUSTRATED HERE**

715182 SCREW  
178489 SPECIAL WASHER

FRAME  
718073 FLANGE NUT  
188490 WASHER  
154177 BUSHING  
175617 STEERING GEAR

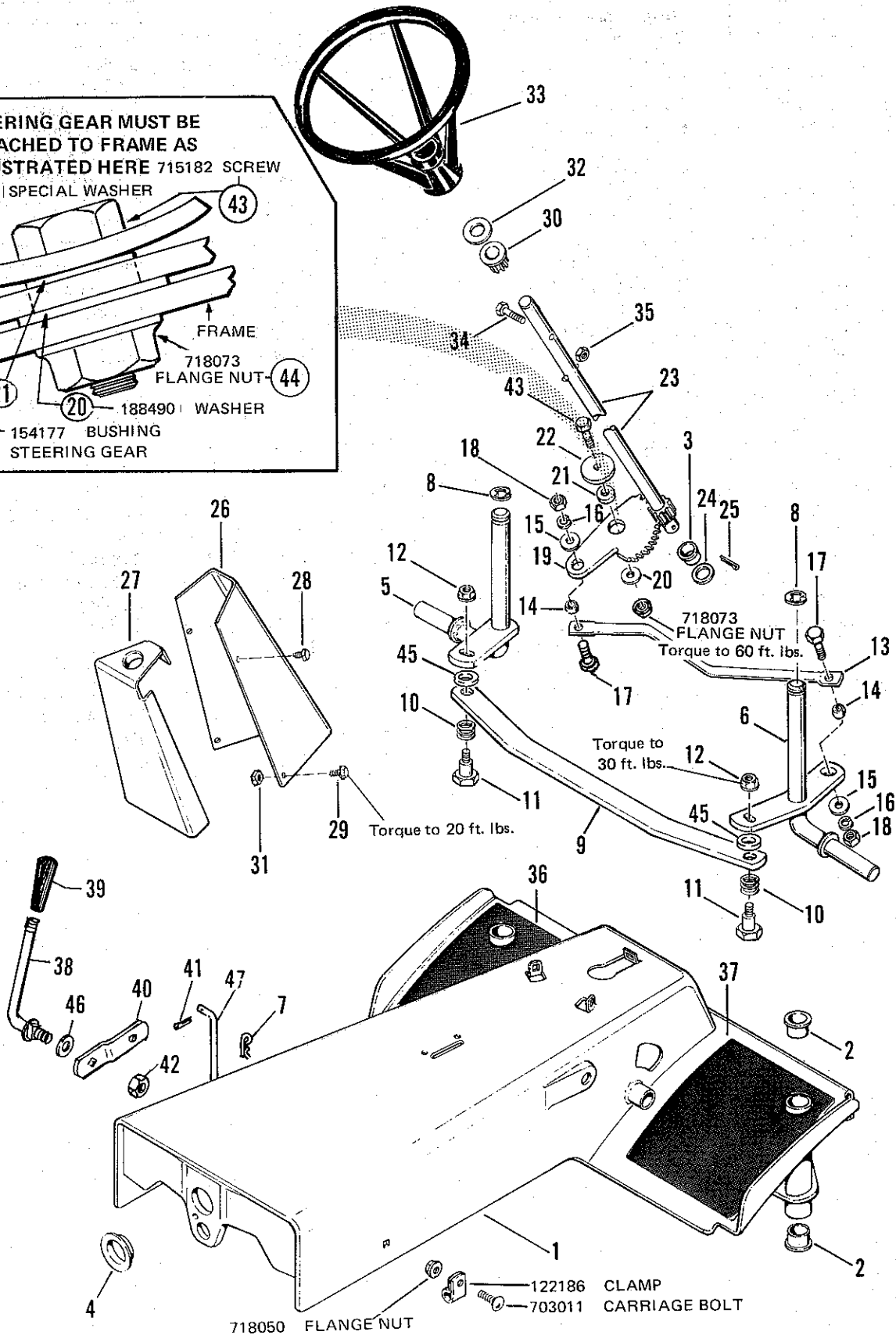

## FRONT FRAME & STEERING

Ref. No.	Part No.	Qty. Req.	Description
1	175452	1	Front Frame Assembly
2	176440	4	Bushing
3	176444	3	Bushing
4	176441	2	Picot Bushing
5	175651	1	L.H. Spindle
6	175654	1	R.H. Spindle
7	106787	1	Clip
8	157286	2	Retaining Ring
9	176711	1	Tie Rod
10	158578	2	Spring
11	7105042	2	Shoulder Bolt
12	718064	2	Flange Nut, 3/8"-26
13	175676	1	Drag Link
14	154177	2	Bushing
15	719002	2	Plain Washer, 5/16"
16	720002	2	Lock Washer, 3/8"
17	705016	2	Hex Capscrew, 3/8"-16 x 1-1/4" lg.
18	717003	2	Hex Nut, Full, 3/8"-16
19	175617	1	Steering Gear
20	178490	1	Washer
21	154177	1	Bushing
22	178489	1	Special Washer
23	175613	1	Steering Pinion Assembly
24	121210	1	Washer
25	722010	1	Cotter Pin, 1/8" x 1-1/4" lg.
26	176389	1	Steering Support
27	176391	1	Rear Panel
28	714003	3	Self-Tapping Screw, No. 10 x 1/2" lg.
29	715060	3	Flange Hd. Screw
30	157077	1	Bushing
31	718032	3	Retainer Nut
32	158223	1	Washer (As Required)
33	176501	1	Steering Wheel
34	715046	1	Hex Capscrew, 5/16"-18 x 1-1/4" lg.
35	717511	1	Hex Nut, Full, Lock, 5/16"-18
36	176809	1	L.H. Foot Pad
37	176810	1	R.H. Foot Pad
38	172040	1	Handle
39	1650149	1	Knob
40	1650145	1	Arm Assembly
41	722016	1	Cotter Pin
42	718064	1	Flange Hex Nut
43	715182	1	Whiz Lock Screw, 3/8"-16 x 1-1/4" lg.
44	718073	1	Flange Nut, 3/8"-26
45	719002	2	Plain Washer, 5/16"
46	101025	1	Washer
47	1650139	1	Rod

## REAR FRAME & SEAT

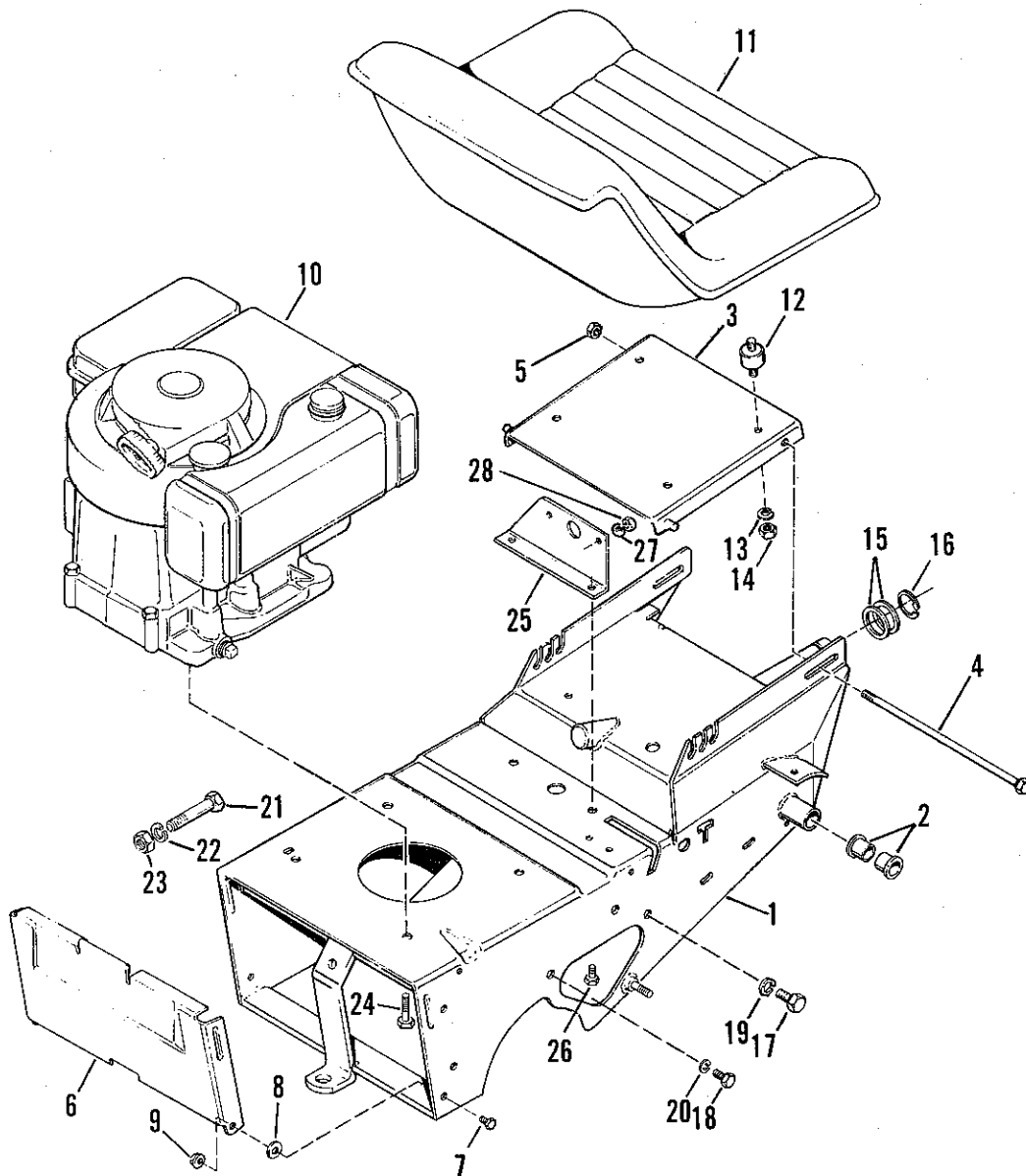

Ref. No.	Part No.	Qty. Req.	Description
1	178007	1	Rear Frame Assembly
2	108419	2	Bushing
3	176491	1	Seat Plate Assembly
4	176848	1	Special Screw, 3/8"-16 x 10" lg.
5	718064	1	Flange Nut, 3/8"-16
6	176494	1	Rear Cover
7	705015	2	Hex Capscrew, 1/4"-20 x 5/8" lg.
8	166161	2	Nylon Washer
9	718049	2	Flange Nut, 1/4"-20
10	177975	1	Engine (Mfg. No. 998)
	177974	1	Engine (Mfg. No. 1000)
11	176495	1	Seat Assembly
12	157094	4	Connector
13	720001	4	Lockwasher, 5/16"
14	717001	4	Hex Nut, 5/16"-18
15	153088	2	Washer

Ref. No.	Part. No.	Qty. Req.	Description
16	158396	1	Retaining Ring
17	705040	2	Hex Capscrew, 7/16"-14 x 3/4" lg.
18	705004	1	Hex Capscrew, 3/8"-16 x 3/4" lg.
19	720006	2	Lockwasher, 7/16"
20	720002	2	Lockwasher, 3/8"
21	715167	1	Hex Capscrew, 7/16"-14 x 2-3/4" lg.
22	720006	1	Lockwasher, 7/16"
23	717022	1	Hex Nut, 7/16"-14
24	715079	4	Special Screw, 3/8"-16 x 1-1/4" lg.
25	176836	1	Engine Plate
26	715114	2	Hex Capscrew, 3/8"-16 x 1/2" lg.
27	720001	2	Lockwasher, 5/16"
28	717001	2	Hex Nut, Full, 5/16"-18



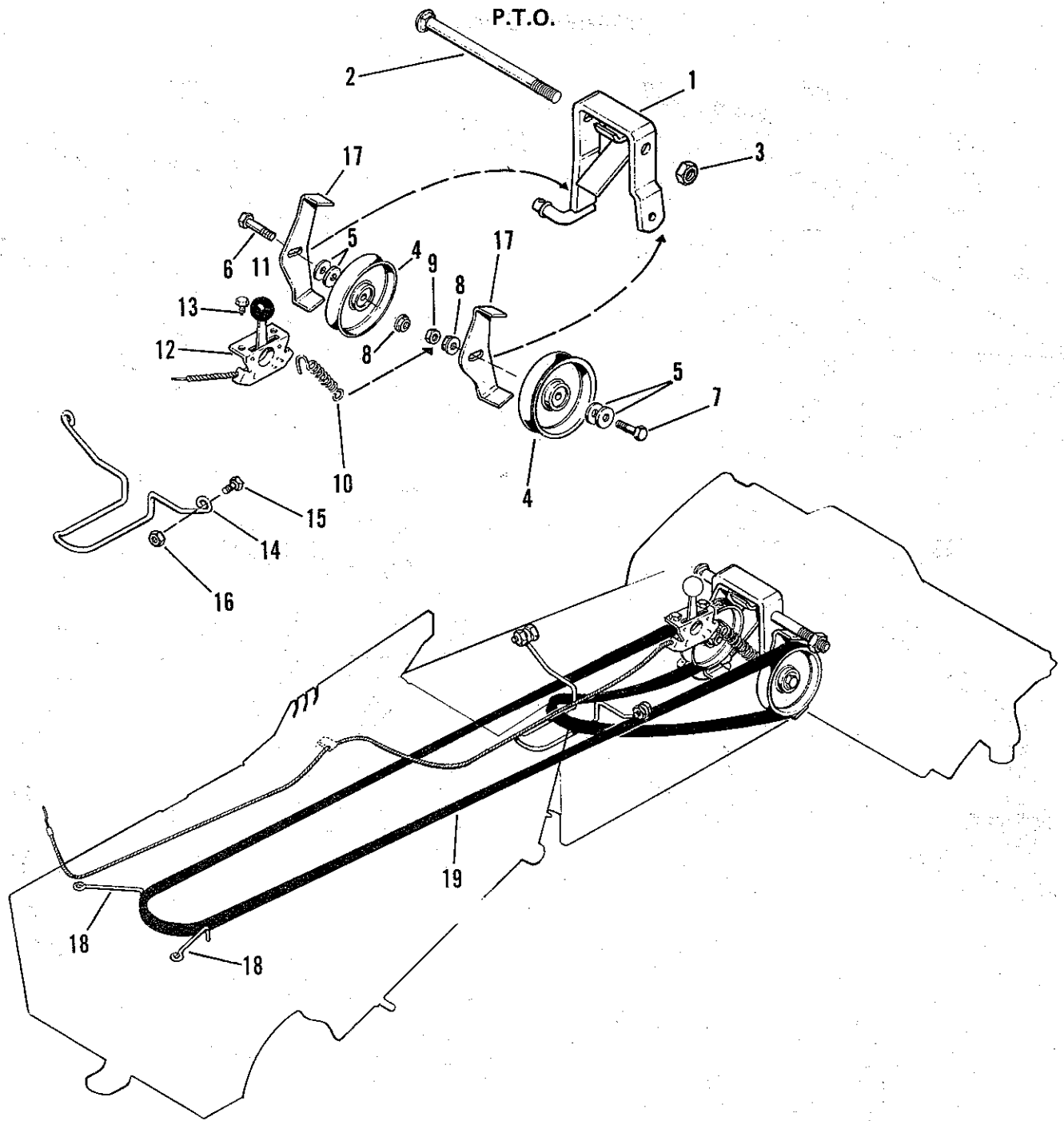

Ref. No.	Part No.	Qty. Req.	Description
1	176749	1	PTO Bracket Assembly
2	702030	1	Carriage Bolt, 1/2"-13 x 8" lg.
3	718063	1	Lock Nut, 1/2"-13
4	175954	2	Pulley
5	157424	4	Special Washer
6	715045	1	Hex Capscrew, 3/8"-16 x 1-3/4" lg.
7	715035	1	Hex Capscrew, 3/8"-16 x 2" lg.
8	718064	2	Flange Nut, 3/8"-26
9	717524	1	Lock Nut, 3/8"-16

Ref. No.	Part No.	Qty. Req.	Description
10	106681	1	Spring
11	172038	1	Knob
12	176868	1	Throttle Control
13	715124	2	Taptite Screw, 1/4"-20 x 3/8"
14	176964	1	Belt Guide
15	705001	2	Hex Capscrew, 5/16"-18 x 7/8" lg.
16	717511	2	Hex Nut, Lock, 5/16"-18
17	176913	2	Belt Guide
18	158499	2	Belt Stop
19	176451	1	"V" Belt

# MOWER HOUSING

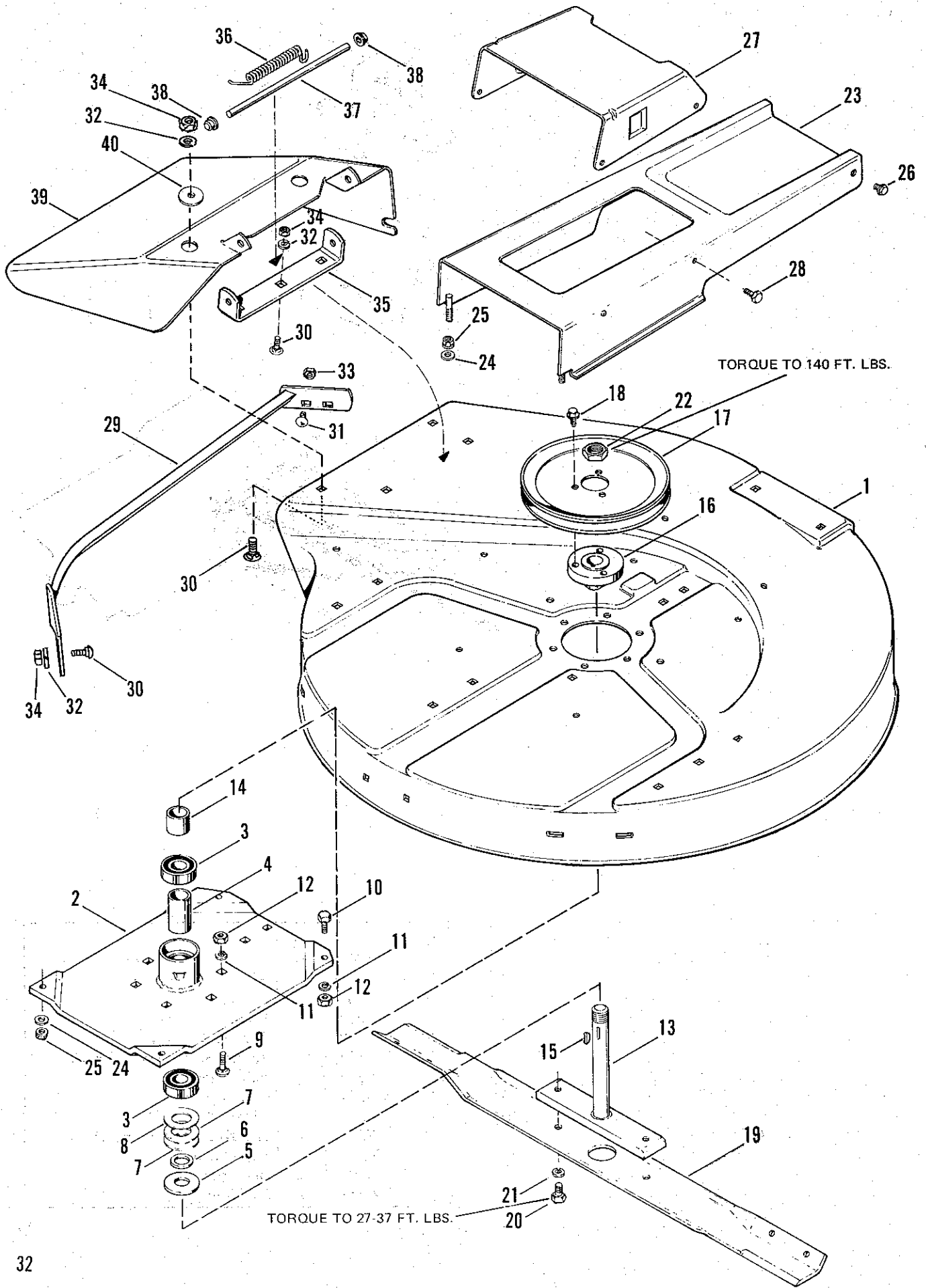

## MOWER HOUSING

Ref. No.	Part No.	Qty. Req.	Description
1	1608351	1	30" Mower Housing
2	176986	1	Arbor Tube Assembly
3	108202	2	Ball Bearings
4	176984	1	Spacer
5	108182	1	Washer, Arbor
6	108181	1	Washer
7	108472	2	Washer
8	108257	1	Washer
9	702024	6	Carriage Bolt, 5/16"-18 x 1" lg.
10	705007	2	Hex Capscrew, 5/16"-18 x 1" lg.
11	720001	8	Lock Washer, 5/16"
12	717001	8	Hex Nut, Full, 5/16"-18
13	176889	1	Arbor Assembly
14	176843	1	Spacer
15	725006	1	Key
16	176340	1	Pulley Hub
17	175941	1	Pulley
18	177932	3	Thread Forming Screw 3/8"-16 x 3/4" lg.
19	176839	1	30" Blade
20	715119	2	Hex Capscrew
21	720002	2	Lock Washer, 3/8"
22	717517	1	Hex Jam Nut, 3/4"-16
23	176772	1	Lower Cover Assembly
24	719002	4	Plain Washer, 5/16"
25	718050	4	Flange Nut, 5/16"
26	715114	2	Hex Capscrew, 3/8"-16 x 1/2" lg.
27	176791	1	Upper Cover
28	715067	2	Screw, Taptite, 1/4"-20 x 3/8"
29	1608374	1	Stone Guard Assembly
30	702015	6	Carriage Bolt, 5/16"-18 x 3/4" lg.
31	703011	2	Carriage Bolt, 5/16"-18 x 1/2" lg.
32	720001	7	Lock Washer, 5/16"
33	717530	2	Hex Nut, Full, Lock, 5/16"-18
34	717001	7	Hex Nut, Full, 5/16"-18
35	1608281	1	Support
36	1608348	1	Spring
37	1608293	1	Pin
38	170015	2	Push Nut
39	1608357	1	Deflector
40	8161199	2	Special Washer

# MOWER CONTROL

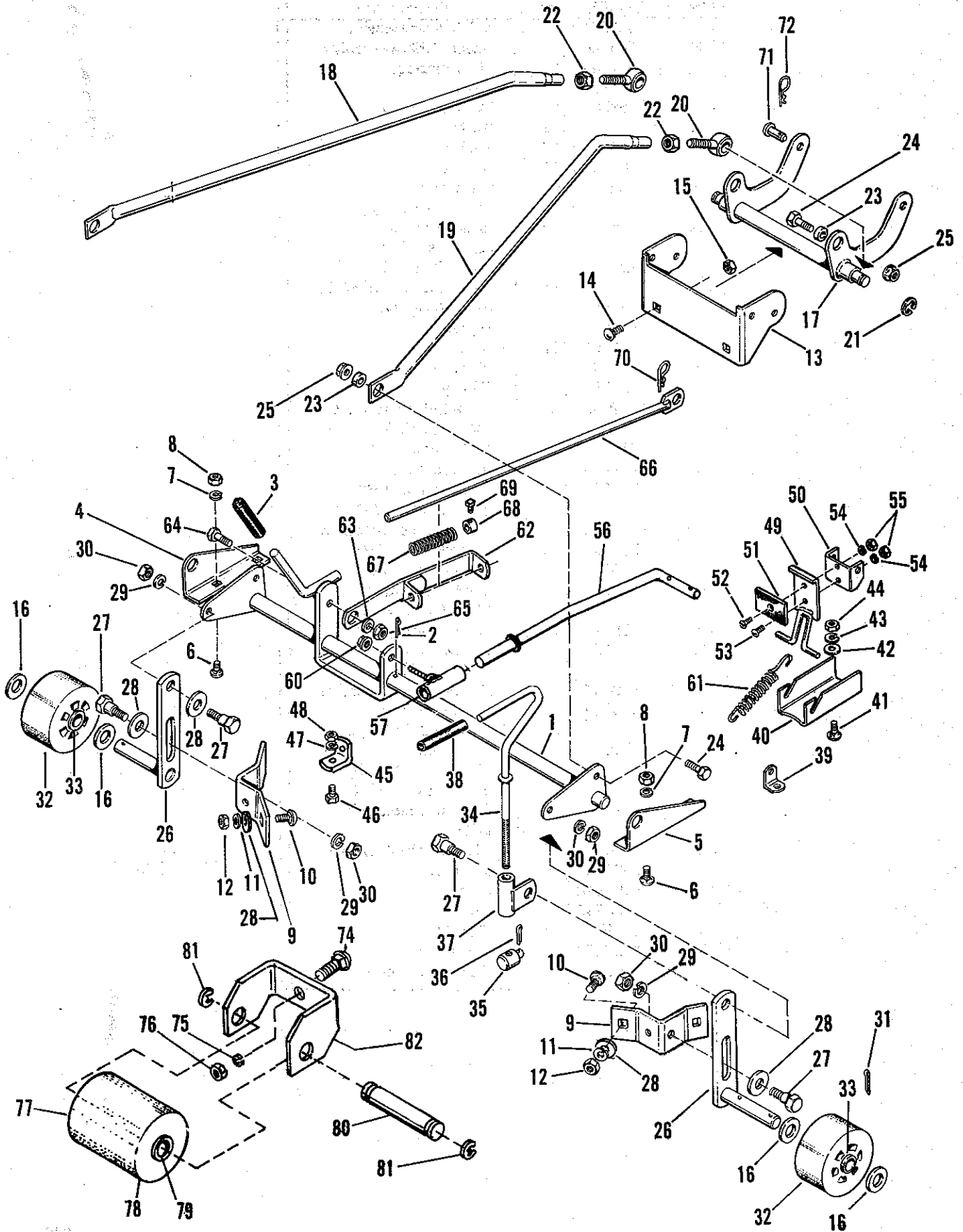

## MOWER CONTROL

Ref. No.	Part No.	Qty. Req.	Description
1	175943	1	Control Arm Assembly
2	722010	2	Cotter Pin, 1/8"x 1-1/4"
3	161105	1	Handle Grip
4	176769	1	L.H. Pivot Bracket
5	176770	1	R.H. Pivot Bracket
6	702022	4	Carriage Bolt, 5/16"-18 x 5/8" lg.
7	720001	4	Lock Washer, 5/16"
8	717001	4	Hex Nut, Full, 5/16"-18
9	1602211	2	Roller Bracket Support
10	702022	4	Carriage Bolt, 5/16"-18 x 5/8" lg.
11	720001	4	Lock Washer, 5/16"
12	717001	4	Hex Nut, Full, 5/16-18
13	176788	1	Front Mower Bracket
14	715082	2	Whiz Lock Screw, 5/16"-18 x 3/4"
15	718033	2	Flange Nut, 5/16"
16	177351	4	Washer
17	175935	1	Rocker Arm Assembly
18	175942	1	L.H. Adjusting Arm
19	176736	1	R.H. Adjusting Arm
20	157215	2	Eye Bolt
21	158399	2	Retaining Ring
22	717016	2	Hex Jam Nut, 1/2-20
23	153081	4	Spacer
24	715096	4	Hex Capscrew, 3/8"-16 x 1" lg.
25	718064	4	Flange Nut
26	1607603	2	Roller Support Assembly
27	1602186	4	Shoulder Bolt
28	719003	6	Plain Washer, 7/16"
29	720002	4	Lock Washer, 3/8"
30	717003	4	Hex Nut, Full, 3/8"-16
31	722011	4	Cotter Pin, 3/16" x 1" lg.
32	1603206	2	Roller Assembly (Includes 2 Ref. No. 33)
33	108419	4	Bushing
34	176775	1	Handle
35	108172	1	Pivot
36	722002	1	Cotter Pin, 3/32" x 1" lg.
37	176777	1	Rod Guide Assembly
38	176985	1	Grip
39	1602446	2	Spring Anchor
40	1607989	1	Pivot Bracket
41	702024	2	Carriage Bolt, 5/16"-18 x 1" lg.

Ref. No.	Part No.	Qty. Req.	Description
42	719002	2	Plain Washer, 5/16"
43	720001	2	Lock Washer, 5/16"
44	717001	2	Hex Nut Full, 5/16-18
45	122052	1	Bracket
46	917397	1	Hex Capscrew, 5/16"-18 x 5/8" lg.
47	720001	1	Lock Washer, 5/16"
48	717001	1	Hex Nut, Full, 5/16"-18
49	176783	1	Brake Support Assembly
50	176785	1	Brake Rod Anchor
51	1610590	1	Brake Sheave
52	709500	1	Flat Hd. Mach. Screw No. 10 - 24 x 5/8" lg.
53	710012	1	Rd. Hd. Mach. Screw No. 10-24 x 1/2" lg.
54	720011	2	No. 10 Lock Washer
55	717023	2	Hex Nut No. 10-24
56	178547	1	Brake Rod
57	178548	1	Rod Guide Assy.
58	1603204	1	Center Roller Bracket
59	108711	1	Shoulder Bolt
60	717510	1	Hex Nut, Full, Lock, 3/8"-16
61	1602894	2	Spring
62	176743	1	Rod Guide Assembly
63	153081	1	Spacer
64	705005	1	Hex Capscrew, 3/8"-16 x 1" lg;
65	718064	1	Flange Nut
66	176874	1	Clutch Rod Assembly
67	162065	1	Spring
68	105201	1	Set Collar
69	713001	1	Set Screw, 1/4"-20x3/8"lg.
70	8161045	1	Spring Clip
71	156306	2	Pin
72	106788	3	Spring Clip
74	702022	2	Carriage Bolt
75	720001	2	Lockwasher
76	717001	2	Hex Nut
77	108431	1	Roller Assembly
78	108178	1	Roller
79	108419	1	Bushing
80	1603205	1	Center Roller Shaft
81	1602155	2	"E" Ring

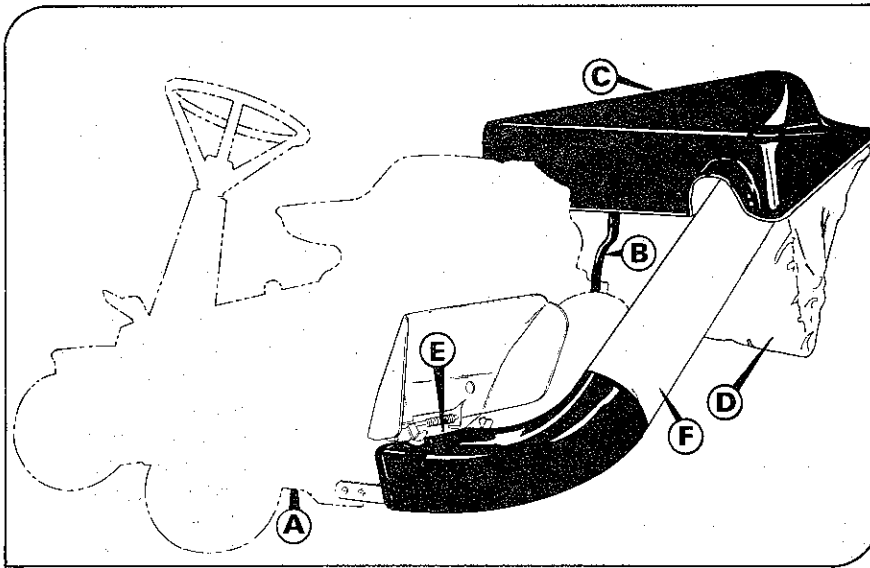

## Assembly Instructions

For

(MFG. NO. 1030)

REAR MOUNTED GRASS CATCHER

(MFG. NO. 975)

FRONT WEIGHT, OPTIONAL

ASSEMBLE IN ALPHABETICAL ORDER OR AREAS

START HERE

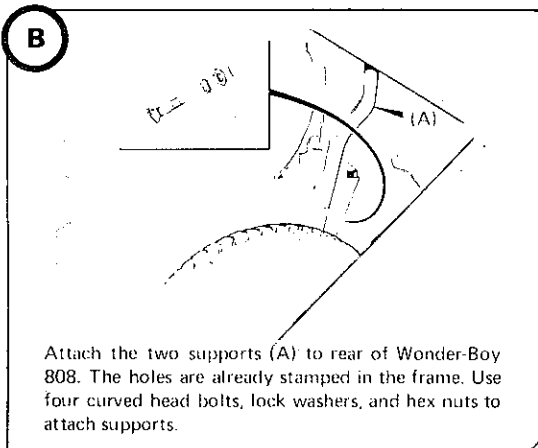
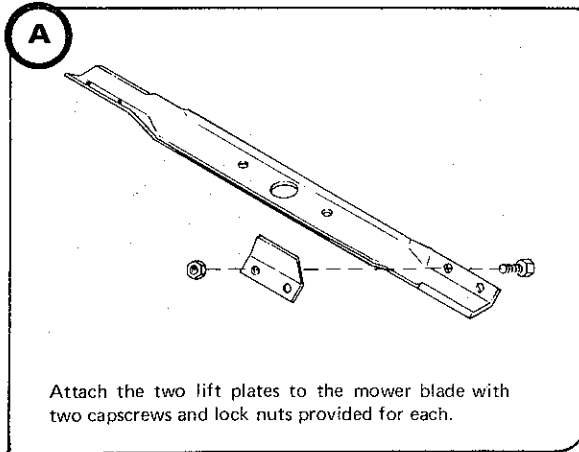

Ref. No.	Part No.	Qty. Req.	Description
1	176871	1	Adaptor
2	123103	2	Nut Assembly
3	703010	2	Carriage Bolt, 5/16-18 x 1"
4	177104	1	Discharge Tube
5	711003	8	Phillips Head Screw, 10-32x1/2"
6	719007	16	Plain Washers, 3/16"
7	721507	8	Lockwasher, No. 10
8	717007	8	Hex Nut, Full, 10-32
9	177086	1	Grass Bag
10	178609	4	Clips
11	178364	1	Support Assembly
12	177019	1	Cover
13	717511	4	Hex Nut, Full Lock, 5/16-18
14	711003	8	Phillips Head Screw, 10-32x1/2"
15	719007	8	Plain Washer, 3/16"
16	721507	8	Lockwasher, No. 10
17	717007	8	Hex Nut, Full, 10-32
18	177096	2	Vertical Support
19	177249	4	Curved Head Bolt
20	720001	4	Lockwasher, 5/16"
21	717001	4	Hex Nut, Full, 5/16-18
22	177243	2	Lift Plate
23	715071	4	Hex Nut, Full, Lock, 5/16-18

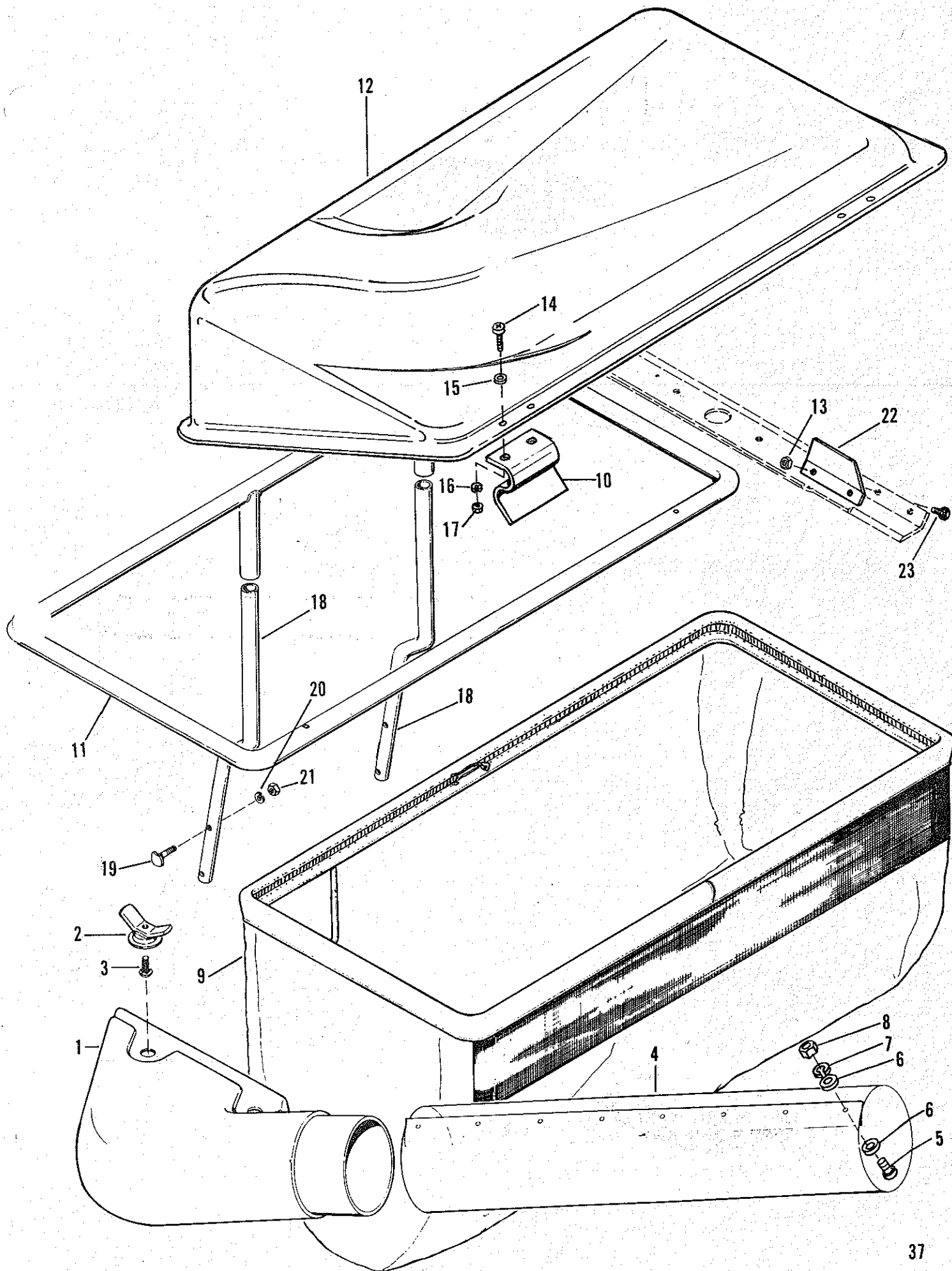

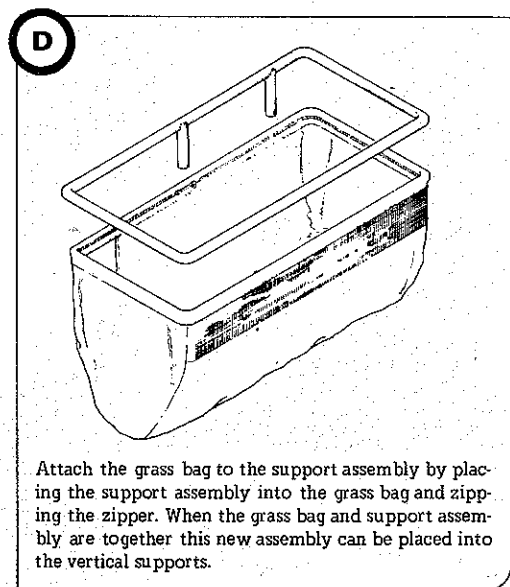
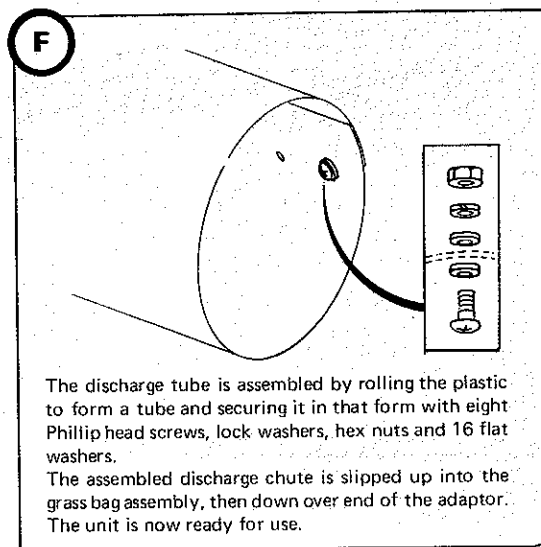
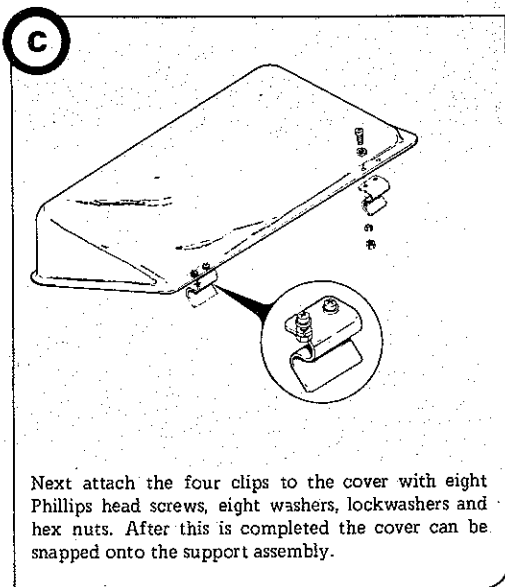

NOTE: One front weight (990975) is recommended when using Rear Mounted Grass Catcher on slopes of 30 to 40 percent.

**MFG. No. 975 Front Weight (Optional)**

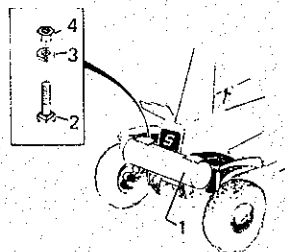

Attach counterweight assembly with two carriage bolts, lock washers and hex nuts. Holes for weight are stamped in frame and are located under rubber foot-pads. After weight is installed replace rubber foot pads over the counterweight assembly.

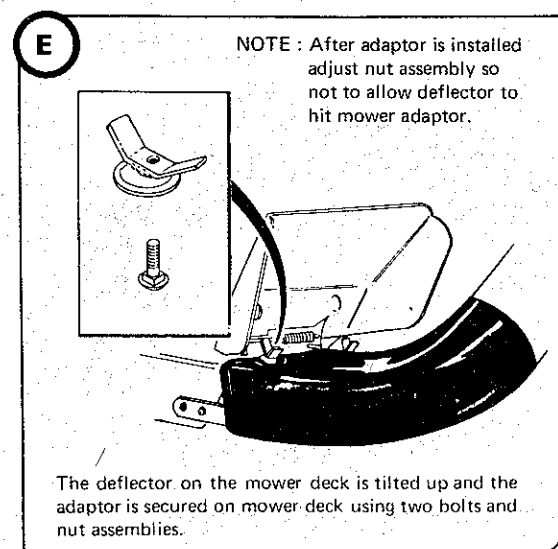

Ref. No.	Part No.	Qty. Req.	Description
1	177397	1	Counterweight Assembly
2	702002	2	Carriage Bolt
3	720002	2	Lock Washer 3/8
4	717003	2	Hex Nut, 3/8-16

NOTE: When it is time to remove the cut grass from the bag, lift up on rear of cover and place it aside. Then lift grass bag and support assembly up and away from discharge tube and vertical supports. Discard cut grass completely.