

7100 SERIES

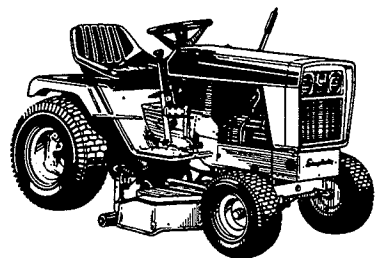

OPERATOR'S MANUAL

Simplicity®

Introduction

This manual covers all Manufacturer's Numbers for hydrostatic, semi-automatic or six speed transmissions (with Ag and Turf tires). Read manual carefully and follow the instructions for your tractor.

HYDROSTATIC

7112 1690473 (TURF)
1690751 (AG)

7114 1690723 (TURF)
1690747 (AG)
1691418

7116 1690477 (TURF)
1690478 (AG)
1690569 (TURF)
1690570 (AG)
1691382

7117 1690479 (TURF)
1690480 (AG)
1690571 (TURF)
1690572 (AG)
1691717

7119 1690638 (TURF)
1690640 (AG)

SEMI-AUTOMATIC

7114 1690474
1690721 (TURF)
1690752 (AG)

7116 1690658 (TURF)
1690660 (AG)

7117 1690725 (TURF)
1690740 (AG)

SIX-SPEED:

7110 1690472

7112 1690644
1690750 (AG)

7116 1690475 (TURF)
1690476 (AG)

7117 1690646 (TURF)
1690648 (AG)

MOWERS

42" 1690501
1691218

48" 1690502
1691219

Contents

ATTACHMENTS & ACCESSORIES	2
SAFETY RULES	4
DECALS	6
OPERATION	9
NORMAL CARE	16
STORAGE	24
TROUBLESHOOTING & BELT REPLACEMENT	25
SEAT ADJUSTMENT	33
PTO CLUTCH ADJUSTMENT - ALL MODELS	33
ADJUSTMENTS — HYDROSTATIC	34
ADJUSTMENTS — SEMI-AUTOMATIC	36
ADJUSTMENTS — SIX SPEED	39
MOWER INSTALLATION	43
MOWER LEVELLING	45
MOWER REMOVAL	46
TRACTOR & MOWER IDENTIFICATION	47
SPECIFICATIONS	48
PARTS MANUAL AVAILABLE	51
COMMON REPLACEMENT PARTS	Inside Back Cover

Optional Attachments & Accessories

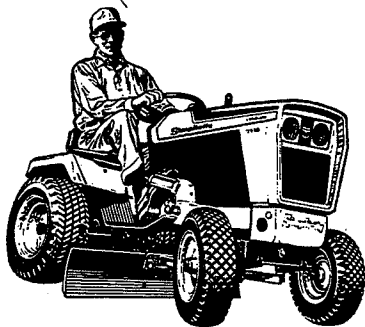

42" GRADER BLADE -
For grading and
levelling jobs.



36" & 38" TILLER -
Powered by tractor PTO.
Self-sharpening tines,
enclosed ends, levelling tail
gate. Tine extension available
for 36" tiller

CULTIVATOR - For seedbed
preparation - rigid shank or
spring tooth models.



**PTO DRIVEN VACUUM
COLLECTOR -** For big job
grass and leaf collection.

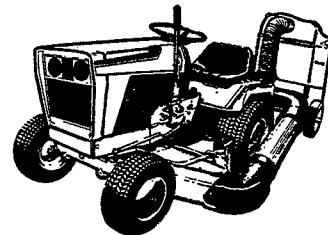

SNOW CAB - Shields
the operator from
blowing snow and
wind.

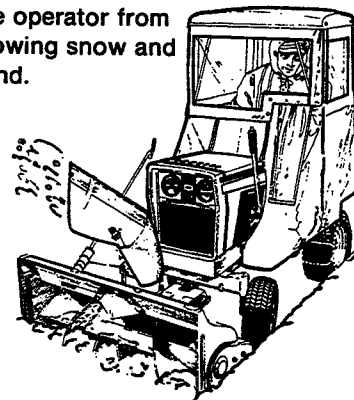

36" & 42" SNOWTHROWER -
Efficient single stage
operation to handle the
heaviest of snow.

NOT ILLUSTRATED

5000 WATT ALTERNATOR supplies electrical power. Driven by tractor PTO.

ROVING NOZZLE used with vacuum collector to collect leaves in hard-to-reach places.

DUMP CART for vacuum collector and hauling chores.

42" & 46" DOZER BLADE for snow removal or dozing.

42" & 48" MOWER for smooth lawn cutting.

MOLDBOARD PLOW for turning the earth.

TIRE CHAINS for traction on slippery surfaces.

HOURMETER to record operating time.

FRONT AND REAR WHEEL WEIGHTS improve traction and stability. Required with some attachments.

HUB CAPS

DUAL LIFT LEVERS when using front & rear attachments simultaneously.

540 RPM POWER TAKEOFF for use with 540 RPM attachments.

REAR LIGHT improves visibility to rear of tractor.

ELECTRIC LIFT raises and lowers attachments by use of a switch.

ELECTRIC SPOUT ROTATOR for control of snowthrower chute. Replaces manual rotator.

TURF TIRES AND AG TIRES

REAR BALL HITCH

REAR LIFT

NOTE: Some attachments require certain accessories.

Safety Rules



Read these safety rules and follow them closely. Failure to obey these rules could result in loss of control of vehicle, severe personal injury to yourself or bystanders, or damage to property or equipment. The triangle  in the text signifies important cautions or warnings which must be followed.

GENERAL

- Read the Operators Manual carefully. Be thoroughly familiar with the controls and the proper use of the equipment.
- Never allow children to operate the machine. Do not allow adults to operate it without proper instruction.
- Do not carry passengers.
- Use only attachments or accessories designed for your machine. See your dealer for a complete list of recommended attachments or accessories.
- Keep the area of operation clear of all persons, particularly small children, and pets.
- Never direct discharge of material toward bystanders.

● Make sure:

- a. tractor and attachments are in good operating condition,
- b. all safety devices and shields are in place and in good working condition, and
- c. all adjustments are correct.

PREPARATION

- Handle gasoline with care - it is highly flammable.
 - a. Use approved gasoline container.
 - b. Never remove the fuel tank cap or add gasoline to a running or hot engine, or fill the fuel tank indoors. Wipe up spilled gasoline.
- Do not run the engine indoors. Exhaust fumes are deadly.

- Clear the work area of objects which might be picked up and thrown by attachments.

- Disengage all attachment clutches and shift into neutral before attempting to start the engine.

- Wear heavy footwear. Do not operate tractor when barefoot or when wearing open sandals or canvas shoes.

OPERATION

- Before leaving the operator's position for any reason, such as to unclog attachment chutes or to make repairs or adjustments, do the following: lower the attachment, shut off engine and remove key, disengage power to attachments, set parking brake, and shift transmission into gear (for hydrostatic tractor, shift into forward range).

- Stop tractor and attachments and inspect for damage after striking a foreign object. Repair any damage before restarting and operating the equipment.

- Watch out for traffic when crossing or operating near roadways.

- Operate only in daylight or in good artificial light.

- Never make any adjustment while the engine is running.
- Avoid using brake to control downhill speed. Select low transmission and engine speed before starting downhill.
- Be especially careful not to touch tractor or attachment parts which might be hot from operation. Allow such parts to cool before attempting to maintain, adjust, or service.
- Stay alert for holes in the terrain and other hidden hazards. Be extra careful when operating on wet or slippery surfaces.
- If equipment begins to vibrate abnormally, disengage power to attachments and stop engine at once. Inspect for damage and correct before starting up tractor.
- Use care when pulling loads or using heavy equipment.
 - a. Use only drawbar hitch point.
 - b. Limit loads to those you can safely control.
 - c. Do not turn sharply. Use care when backing.

- d. Use weights when recommended in the tractor or attachment Operators Manual.



WARNING

Slope Operation

Never operate on slopes greater than 35 percent (19.3°) which is a rise of 3.5 feet (1067 mm) vertically in 10 feet (3.1 m) horizontally. When operating on slopes that are greater than 20 percent (11.3°) use rear wheel weights (see your dealer). Select slow ground speed before driving onto slope. Do not use brakes to control speed. On Semi-Automatic and Six Speed models, do not attempt to shift gears while on slopes because once out of gear, it may not be possible to shift into another gear. Mow UP and DOWN the slope, never across the face, use caution when changing directions and **DO NOT START OR STOP ON SLOPES.**

- Disengage power to attachment(s) when transporting or not in use.
- Reduce speed before approaching sharp turns to avoid tipping or loss of control.

MAINTENANCE & STORAGE

- Keep all nuts, bolts and screws tight to be sure the equipment is in safe working condition.
- To reduce fire hazard, keep the engine and mower free of grass, leaves and excess grease.
- Never store the equipment with gasoline in the tank inside of building where fumes may reach an open flame or spark. Allow the engine to cool before storing in any enclosure.

ALL WARNING, CAUTION, and instructional messages on your tractor and mower should be carefully read and obeyed. Personal bodily injury can result when these instructions are not followed. The information is for your safety and it is important. The safety messages on the following pages are on your tractor and mower.

Decals

⚠ DANGER



ROTATING CUTTING BLADE

- DO NOT OPERATE MOWER WITHOUT DEFLECTOR OR ENTIRE GRASS CATCHER IN PLACE.



CAUTION

DISCONNECT GROUND (-) TERMINAL WHEN WORKING ON ELECTRICAL SYSTEM TO PREVENT SHORT CIRCUIT

⚠ DANGER

ROTATING CUTTING BLADE

- DO NOT PUT HANDS OR FEET UNDER MOWER DECK WHILE BLADE IS ROTATING.

CHOKE  LIGHTS  IGNITION SWITCH OFF ON START 

⚠ CAUTION

TO AVOID POSSIBLE INJURY

- READ OPERATOR'S MANUALS.
- KNOW LOCATION AND FUNCTION OF ALL CONTROLS.
- KEEP SAFETY DEVICES (GUARDS, SHIELDS AND SWITCHES) IN PLACE AND WORKING.
- REMOVE OBJECTS THAT COULD BE THROWN BY BLADE.

BRAKE-CLUTCH PEDAL
ENGAGE CLUTCH APPLY BRAKE

PARKING BRAKE LEVER
ON OFF

↑ CENTER PTO ENGAGE
↓ DISCONNECT

- DO NOT MOW WHEN CHILDREN AND OTHERS ARE AROUND.
- NEVER CARRY CHILDREN.
- ALWAYS LOOK BEHIND MACHINE BEFORE BACKING.
- DO NOT MOW WHERE MACHINE COULD TIP OR SLIP.
- IF MACHINE STOPS GOING UPHILL, STOP BLADE AND BACK SLOWLY DOWN.
- BE SURE BLADE AND ENGINE ARE STOPPED BEFORE PLACING HANDS OR FEET NEAR BLADE.
- WHEN LEAVING MACHINE REMOVE KEY AND SET PARKING BRAKE.

⚠ CAUTION: DO NOT TOW TRACTOR. DAMAGE WILL RESULT TO HYDROSTATIC TRANSMISSION.



Location: Console on Hydro-static Tractor

⚠ WARNING

TO AVOID INJURY DO NOT RUN ENGINE WITH SEAT DECK RAISED

CHOKES 

LIGHTS 

IGNITION SWITCH OFF  ON  START

FOR YOUR SAFETY
 TO START ENGINE - SHIFT LEVER MUST BE IN NEUTRAL AND PTO DISENGAGED.
 KEEP HANDS, FEET AND CLOTHING AWAY FROM POWER DRIVE PARTS.

BRAKE-CLUTCH PEDAL
 ENGAGE CLUTCH → APPLY BRAKE

1 START → 3
 2 R

KEEP ALL SHIELDS IN PLACE.
 KEEP PEOPLE AND PETS A SAFE DISTANCE AWAY FROM MACHINE.

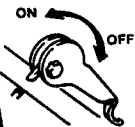
PARKING BRAKE LEVER
 ON  OFF

BEFORE LEAVING OPERATOR'S POSITION:

1. SHUT OFF ENGINE AND REMOVE KEY.
2. DISENGAGE PTO CLUTCH.
3. SET PARKING BRAKE.
4. SHIFT TRANSMISSION INTO FORWARD GEAR.
5. WAIT FOR ALL MOVEMENT TO STOP BEFORE SERVICING MACHINE.



WARNING: BEFORE LEAVING THE TRACTOR, SET PARKING BRAKE. DO NOT RELY ON TRANSMISSION TO HOLD TRACTOR.

1566754

Location: Console on Semi-Automatic Tractor

CHOKES 

LIGHTS 

IGNITION SWITCH OFF  ON  START

FOR YOUR SAFETY
 TO START ENGINE - SHIFT LEVER MUST BE IN NEUTRAL AND PTO DISENGAGED.
 KEEP HANDS, FEET AND CLOTHING AWAY FROM POWER DRIVE PARTS.

BRAKE-CLUTCH PEDAL
 ENGAGE CLUTCH → APPLY BRAKE

1 START → 3
 2 4

KEEP ALL SHIELDS IN PLACE.
 KEEP PEOPLE AND PETS A SAFE DISTANCE AWAY FROM MACHINE.

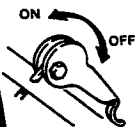
PARKING BRAKE LEVER
 ON  OFF

BEFORE LEAVING OPERATOR'S POSITION:

1. SHUT OFF ENGINE AND REMOVE KEY.
2. DISENGAGE PTO CLUTCH.
3. SET PARKING BRAKE.
4. SHIFT TRANSMISSION INTO FORWARD GEAR.
5. WAIT FOR ALL MOVEMENT TO STOP BEFORE SERVICING MACHINE.

WARNING: BEFORE LEAVING THE TRACTOR, SET PARKING BRAKE. DO NOT RELY ON TRANSMISSION TO HOLD TRACTOR.

1566875

Location: Console on Six Speed Tractor

Operation

CONTENT OF SECTION

Starting the Engine - Page 9

Operating the Hydrostatic Tractor - Page 10

Operating the Semi-Automatic Tractor -
Page 12

Operating the Six-Speed Tractor - Page 14

INTERLOCK SWITCHES

Mfg. nos. 1691382 and higher are equipped with a seat switch which will stop the engine if the operator leaves seat when PTO is engaged and/or transmission is in gear. On all models, the transmission must be in NEUTRAL and PTO disengaged to start engine.



WARNING

To reduce fire hazard, keep the engine and mower free of grass, leaves and excess grease.



WARNING

Refer to your attachment Operator's Manual for special requirements. When mowing with a vacuum collector attachment, always use the front wheel weights.



WARNING

Slope Operation

Never operate on slopes greater than 35 percent (19.3°) which is a rise of 3.5 feet (1067 mm) vertically in 10 feet (3.1 m) horizontally. When operating on slopes that are greater than 20 percent (11.3°) use rear wheel weights (see your dealer). Select slow ground speed before driving onto slope. Do not use brakes to control speed. On Semi-Automatic and Six Speed models, do not attempt to shift gears while on slopes because once out of gear, it may not be possible to shift into another gear. Mow UP and DOWN the slope, never across the face. Use caution when changing directions and **DO NOT START OR STOP ON SLOPES.**

STARTING THE ENGINE

NOTE

Refer to figure 1, 2, or 3 to identify the controls for your tractor.

Checks Before Starting

1. Make sure you have proper wheel weights or counterweights if required. See the warnings on page 8. Make sure any slopes are within required limits.
2. Check that crankcase is filled to full mark on dipstick. See the engine Operator's Manual for instructions and oil recommendations.
3. Make sure all nuts, bolts, screws and pins are in place and tight.



WARNING

Gasoline is highly flammable and must be handled with care. Never fill the tank when the engine is still hot from recent operation. Do not allow open flame, smoking or matches in the area. Avoid overfilling and wipe up any spills.

4. Make sure you can reach all controls from operator's position. If not, see Seat Adjustment, page 33.
5. Fill the gasoline tank with a good grade of fresh gasoline. DO NOT mix oil with gasoline. Refer to engine manual for gasoline recommendations.
6. For hydrostatic tractors, be sure free wheeling latch on hydrostatic pump is engaged. See "Moving Tractor Without Engine Power" (page 10).

Starting the Engine

NOTE

Also see engine manual for recommendations. Do not idle engine for extended periods, it may cause carbon buildup.

1. Seat yourself in the operator's position. Make sure parking brake is set (pulled up and back against fender).
2. On 6-speed tractors depress clutch-brake pedal and place gear shift lever in neutral. Place PTO lever in disengaged position.

On hydrostatic tractors, place the hydrostatic control lever in neutral position. Place PTO lever in disengaged position.

On semi-automatic tractors place vehicle motion lever (D, figure 2) in neutral position. Place PTO lever in disengaged position.

3. Depress clutch-brake pedal and apply braking pressure. Keep clutch disengaged until engine starts. (On 6-speed tractors, keep clutch disengaged until you are ready to operate.)
4. Pull choke out (unless engine is warm).
5. Set engine speed control to SLOW.
6. Turn ignition key to START. When engine starts, release key. If the engine does not start within 30 seconds, allow starter motor to cool for a minute before making a second attempt.
7. As engine warms up, push choke fully in. Allow engine to warm up for a few minutes before applying a load. See page 10, 12 or 13 to start operation.

OPERATING THE HYDROSTATIC TRACTOR

Moving Tractor Without Engine Power - Hydrostatic Only

Normally, the hydrostatic transmission will not allow the tractor to be pushed. To push the tractor, push the free wheeling latch (figure 9) down. This will disengage the transmission. To engage the transmission, pull the latch up.



CAUTION

Towing the hydrostatic tractor will cause transmission damage. Do not use another vehicle to push or pull the tractor.

3. Push transmission control lever to the right to clear the neutral notch. Move lever slowly forward to move tractor forward or pull lever back to move tractor rearward.
4. Adjust engine speed control for desired engine speed. Adjust transmission control lever to desired ground speed. See Table 1. Engage the PTO with moderately fast motion to avoid belt wear.
6. Before leaving tractor seat, do the following:
 - a. Lower the attachment.
 - b. Move engine speed control to SLOW. Allow to idle momentarily then shut off engine and remove key.
 - c. Disengage power to attachment.
 - d. Set parking brake.
 - e. Move transmission control lever to forward position.





Mowing Conditions	Engine Speed Control	Hydrostatic Lever Position
Rotary Mower (Smooth terrain-normal grass)		
Rotary Mower (Rough terrain-heavy or wet grass)		

Table 1. Hydrostatic Operation Chart

Starting & Stopping - Hydrostatic

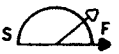
1. Start the engine (see page 9). Set engine speed control between 1/4 and 1/2. Make sure transmission control lever is in neutral, then release clutch-brake pedal. The attachment can be raised to transport position, if desired.
2. Make sure path in desired direction of travel is clear. Release parking brake.

5. To stop tractor motion, move transmission control lever to the neutral position notch. For a faster stop, depress the clutch-brake pedal fully.

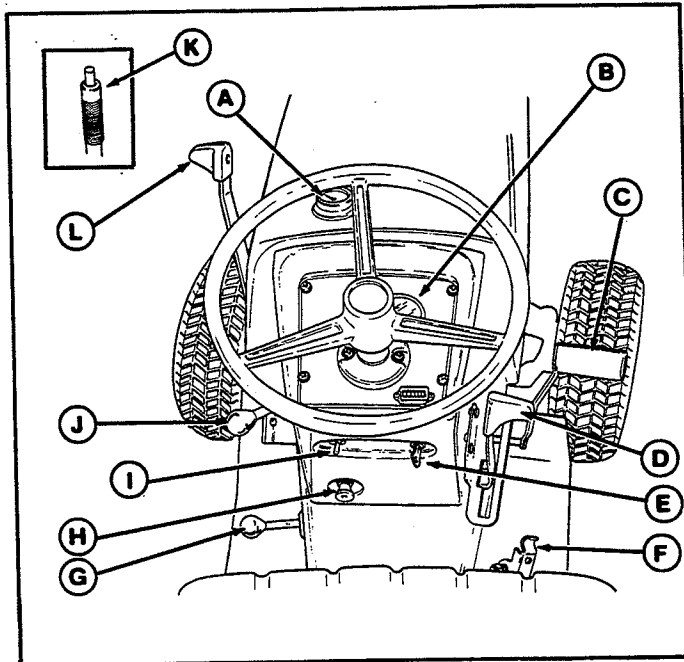

Figure 1. Hydrostatic Controls

ITEM	NAME	FUNCTION
A	Gasoline Gauge	Shows gasoline level and serves as tank cap.
B	Ammeter	Shows when battery is being charged or discharged.
C	Clutch-Brake Pedal	Disengages clutch when depressed at least halfway. Applies brake when depressed fully.
D	Transmission Control Lever	Controls tractor speed and direction of travel (forward or reverse).
E	Ignition Switch	Operates with key to start, run or stop engine.
F	Parking Brake Lever	Locks brake to hold tractor in parked position.
G	PTO Lever	Engages and disengages power to attachments.
H	Choke Knob	When pulled out, closes engine choke for cold weather starting.
I	Light Switch	Switches headlights on or off.
J	Engine Speed Control	Controls engine speed.
K	Manual Lift Lever	Lifts and holds attachments in transport position.
L	Hydraulic Lift (if equipped)	Lifts and holds attachments in transport position.

OPERATING THE SEMI-AUTOMATIC TRACTOR

1. Start the engine (see page 9). Set engine speed control between 1/4 and 1/2. Make sure vehicle motion lever is in neutral then release clutch-brake pedal.
2. With vehicle motion control lever in neutral, place gear shift lever in desired gear. See Table 2.



Mowing Conditions	Engine Speed Control	Transmission Gear Selection
Rotary Mower (Smooth terrain-normal grass)		
Rotary Mower (Rough terrain-heavy or wet grass)		

Table 2. Semi-Automatic Operation Chart

3. Make sure path in desired direction of travel is clear. Release parking brake.
4. Slowly move the vehicle motion control lever forward to move forward or back to move in reverse. The tractor can be

“creeped” by holding lever part way toward locked drive position, but doing this for a long period of time will cause drive clutch wear. For normal driving, lock the lever all the way in drive position.

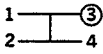
5. Adjust engine speed control to desired engine speed. See Table 2.
6. To shift gears, tractor motion must be completely stopped. Engage the PTO with moderately fast motion to avoid belt wear.
7. To stop, move the vehicle motion control lever smoothly from drive position to neutral position and then partway into opposite direction range until tractor stops. When tractor stops, move lever into neutral. The tractor can also be stopped gradually by pressing the pedal down halfway. For a faster stop, depress the clutch-brake pedal fully.

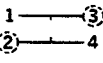
8. Before leaving the tractor seat, do the following:
 - a. Lower the attachment.
 - b. Move engine speed control to SLOW. Allow to idle momentarily, then shut off engine and remove key.
 - c. Disengage power to attachments.
 - d. Set parking brake.
 - e. Shift transmission into forward gear.

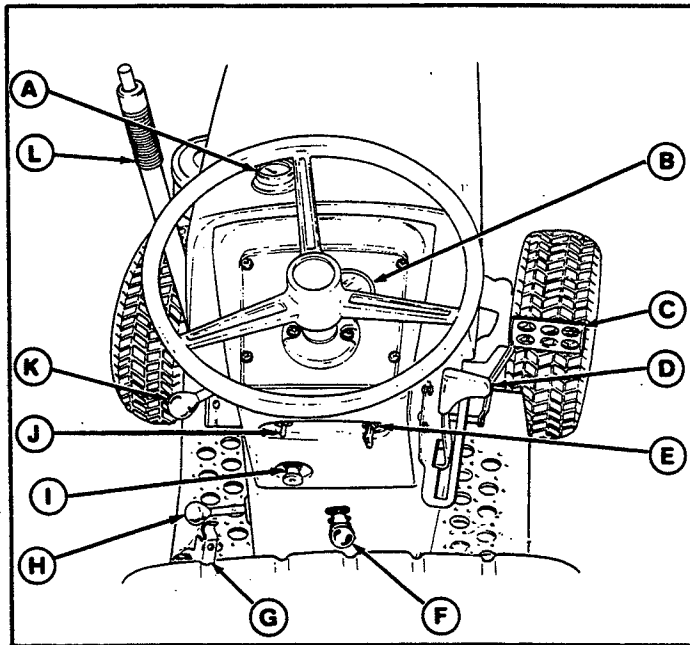

Figure 2. Semi-Automatic Controls

ITEM	NAME	FUNCTION
A	Gasoline Gauge	Shows gasoline level and serves as tank cap.
B	Ammeter	Shows when battery is being charged or discharged.
C	Clutch-Brake Pedal	Disengages clutch when depressed at least halfway. Applies brake when depressed fully.
D	Vehicle Motion Control Lever	Controls direction of travel (forward or reverse).
E	Ignition Switch	Operates with key to start, run or stop engine.
F	Gear Shift Lever	Shifts transmission gears
G	Parking Brake Lever	Locks brake to hold tractor in parked position.
H	PTO Lever	Engages and disengages power to attachments.
I	Choke Knob	When pulled out, closes engine choke for cold weather starting.
J	Light Switch	Switches headlights on or off.
K	Engine Speed Control	Controls engine speed.
L	Lift Lever	Lifts and holds attachments in transport position.

OPERATING THE SIX-SPEED TRACTOR

1. With engine running, set engine speed control between 1/4 and 1/2.
2. With the clutch-brake pedal fully depressed, use gear shift lever to select desired gear. See Table 3. Move the speed range lever forward for high range or back for low range.



Mowing Conditions	Engine Speed Control	Speed Range	Trans. Gear
Rotary Mower (Smooth terrain-normal grass)		LO	3
		HI	2
Rotary Mower (Rough terrain-heavy or wet grass)		LO	2
		HI	1

Table 3. Six Speed Operation Chart

3. Make sure path in desired direction of travel is clear. Release parking brake.
4. Release clutch-brake pedal slowly to start tractor into motion.
5. Adjust engine speed control to desired engine speed.

6. To shift gears, the tractor must be completely stopped and clutch-brake pedal completely depressed. Engage the PTO with moderately fast motion to avoid belt wear.
7. To stop, depress clutch-brake pedal until tractor stops. Pressing pedal down about halfway will give a gradual stop. Pressing pedal down farther will give a more rapid stop.
8. Before leaving the tractor seat, do the following:
 - a. Lower the attachment.
 - b. Move engine speed control to SLOW. Allow to idle momentarily, then shut off engine and remove key.
 - c. Disengage power to attachments.
 - d. Set parking brake.
 - e. Shift transmission into forward gear.

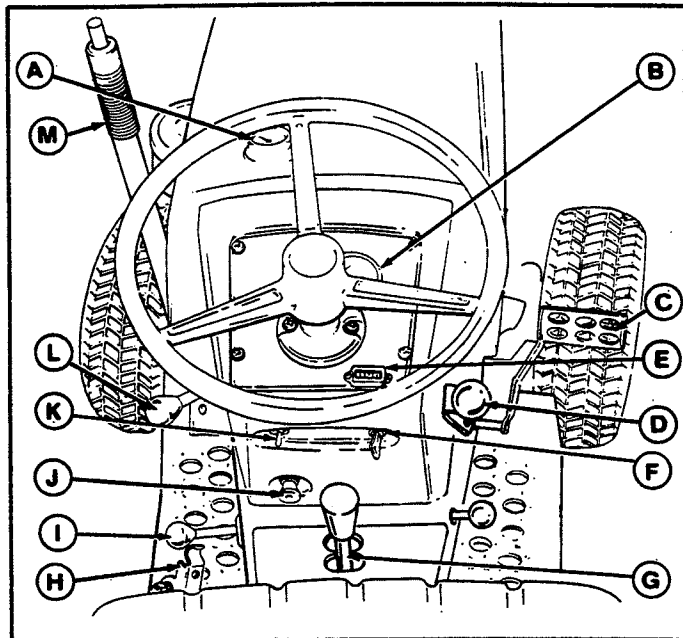

Figure 3. Six Speed Controls

ITEM	NAME	FUNCTION
A	Gasoline Gauge	Shows gasoline level and serves as tank cap.
B	Ammeter	Shows when battery is being charged or discharged.
C	Clutch-Brake Pedal	Disengages clutch when depressed at least halfway. Applies brake when depressed fully.
D	Speed Range Lever	Controls tractor speed. Clutch pedal must be depressed to shift lever.
E	Hourmeter (Optional)	Records operating hours of tractor.
F	Ignition Switch	Operates with key to start, run or stop engine.
G	Gear Shift Lever	Shifts transmission gears.
H	Parking Brake Lever	Locks brake to hold tractor in parked position.
I	PTO Lever	Engages and disengages power to attachments.
J	Choke Knob	When pulled out, closes engine choke for cold weather starting.
K	Light Switch	Switches headlights on or off.
L	Engine Speed Control	Controls engine speed.
M	Lift Lever	Lifts and holds attachments in transport position.

Normal Care

NORMAL CARE SCHEDULE

Refer to the engine manual for normal care of engine. See Table 4 for a schedule of normal care for tractor and mower.



WARNING

Before performing maintenance, lower the attachment, shut off engine and remove key, disengage power to attachments, set parking brake, and shift transmission into gear (for hydrostatic tractor, shift into forward range).

Care Required	Schedule			
	See Page	Every 5 Hours	Every 25 Hours	Every 100 Hours Or Yearly
Check for loose hardware.	—	•		
Check tires.	18		•	
Lubricate tractor.	17		•	
Check bevel gear box fluid level.	18		•	
Check transmission fluid.	19			•
Check trans. screen (Hydro only).	20	•		
Grease planetary assy. (Semi-Automatic).	21			•
Clean and check battery.	18		•	
Clean engine cooling fins.	—	•		
Repack front wheel bearings.	18			•
Lubricate mower idler pulley pivot.	22			•
Clean, sharpen & balance blades.	22			•
SEE ENGINE MANUAL FOR ENGINE CARE				

Table 4. Normal Care Schedule - Tractor & Mower

LUBRICATE TRACTOR

1. There are six grease fittings on the tractor. Wipe fittings clean before greasing. Use a standard grease gun with general purpose automotive grease.
 - a. One fitting in each front axle spindle (right-hand spindle shown in figure 4).

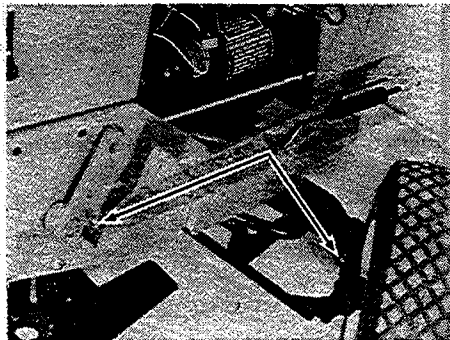

Figure 4. Grease Fittings

- b. One fitting on clutch-brake pedal (figure 4);
- c. One fitting on steering gear under tractor (figure 5);
- d. Two fittings on the right hand rear axle (figure 6).

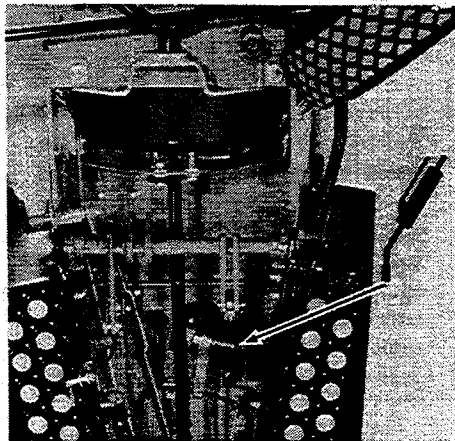

Figure 5. Grease Fitting

2. A few drops of engine oil should be placed on the numerous pivot points and moving parts of the tractor and mower. Keep oil off belts and pulleys to prevent belt damage. Place oil at all points where metal parts rub together, such as rods and rod guides, levers, etc.

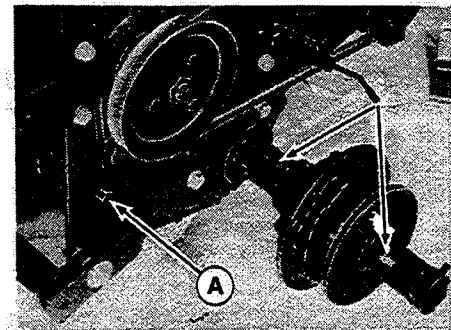

Figure 6. Grease Fittings

A. Oil Level/Fill Plug

CHECK BEVEL GEAR BOX FLUID LEVEL

Check the bevel gear box fluid level. Remove the fill plug (A, figure 7) and wipe oil off attached pin. Insert the fill plug loosely in hole (do not screw in). In this position the fluid should just touch the bottom of the pin. If not, add multipurpose power train oil. Do not overfill. A drain plug (C) is located on rear cover.

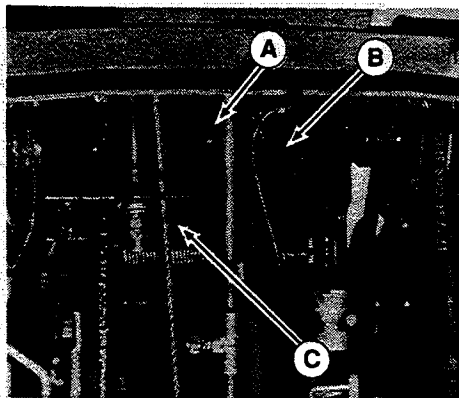

Figure 7. Bevel Gear Box

- A. Oil Fill/Check Plug
- B. Bevel Gear Box
- C. Drain Plug

CLEAN AND CHECK BATTERY



WARNING

Always disconnect the negative cable **FIRST** and reconnect it **LAST**. The positive terminal can easily be shorted to the tractor frame by a wrench or other tool if this is not done. Avoid spilling electrolyte. Keep flames and sparks away from the battery to avoid an explosion. After reconnecting the cables, make sure the cover is in place over the positive terminal.

1. The battery and cables can be cleaned with baking soda and water. Clean the terminals and clamps with a wire brush. Coat the clamps with grease or petroleum jelly to inhibit corrosion.
2. Remove the caps to check the fluid level. The fluid should be even with the split ring full mark. If not, add distilled water.

CHECK TIRES

Check the air pressure of all four tires. Front tire pressure should be 12 to 15 psi (82 to 103 kPa). Rear tire pressure should be 6 to 8 psi (41 to 55 kPa).

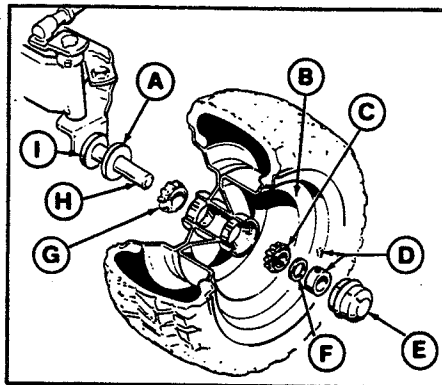

Figure 8. Repack Front Wheel Bearings

- | | |
|----------------------|------------------|
| A. Seal | F. Washer |
| B. Wheel | G. Inner Bearing |
| C. Outer Bearing | H. Spindle |
| D. Collar & Setscrew | I. Spacer |
| E. Grease Cup | |

REPACK FRONT WHEEL BEARINGS

1. Block or jack up front of tractor for wheel removal.
2. Pry off grease cup with a screwdriver or a claw hammer (figure 8).
3. Loosen collar setscrew using an Allen wrench.
4. Remove collar, washer and outer bearing.

NOTE

Keep the two bearings separated. Each should be put back in its original place.

5. Remove wheel and inner bearing.
6. Wash wheel shaft, bearings and internal part of wheel. Use a solvent and remove all old grease. Wipe dry.
7. Inspect seal. If seal is damaged, replace it.

NOTE

Use only a prime quality wheel bearing grease. Keep grease clean and free of dirt.

8. Coat seal and spindle with grease.
9. Lubricate bearings completely with grease. Use hand to force grease and fill spaces between bearing rollers.
10. Install inner bearing, washer and collar.
11. Install outer bearing, washer and collar.
12. Press collar towards tractor and spin wheel slowly to seat bearing.
13. When wheel and bearings are seated and against seal, hold collar and tighten setscrew securely.

14. Test seating by attempting to wobble wheel. If wobble is more than just evident, loosen setscrew and repeat steps 12, 13 and 14.
15. Replace grease cup and wipe up any excess grease.
16. Repeat entire procedure for other wheel.

CHECK TRANSMISSION FLUID — SIX SPEED & SEMI-AUTOMATIC

Oil level should be maintained up to the bottom of the oil level/fill plug (figure 8A). Fill with power train oil such as Simplicity

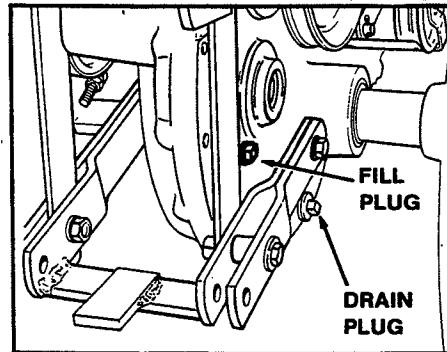

Figure 8A. Transmission Fluid Check — Six Speed and Semi-Automatic

Multi-Purpose Hydraulic/Transmission Oil or Deutz-Allis Power Fluid 821.

CHECK TRANSMISSION FLUID — HYDROSTATIC

1. The tractor must be on a level surface and the free wheeling latch (A, figure 9) must be completely down.
2. Wipe the transmission fill cap (C) and fill tube (D) clean. Remove the cap (C).
3. Lift and hold the relief valve (E) open.
4. Fluid should be at top of filler pipe. If not, add Simplicity Multi-Purpose Hydraulic/Transmission Oil, Type F automatic transmission fluid, or Deutz-Allis Power Fluid 821.

NOTE

The filter should be replaced every 400 hours of operation. See page 20.

CHANGE TRANSMISSION FLUID & FILTER — HYDROSTATIC

NOTE

The filter is shown in figure 9. On early models, filter is mounted underneath transmission. Replace the filter every 400 hours of operation or whenever changing transmission fluid. Transmission fluid should be changed only when performing repair work on transmission or hydrostatic unit or if it becomes discolored from overheating.

1. With hydrostatic transmission fluid hot, park tractor on level ground, place transmission control lever in neutral, place any PTO clutch levers in the disengaged position, engage parking brake, and stop engine. Press free wheeling latch (figure 9) down firmly to disengage the hydrostatic pump.
2. Remove hydrostatic transmission drain plug (B, figure 10) from lower right hand side. Remove dirt from around the fill cap (C, figure 9) and loosen cap to permit air to enter transmission.

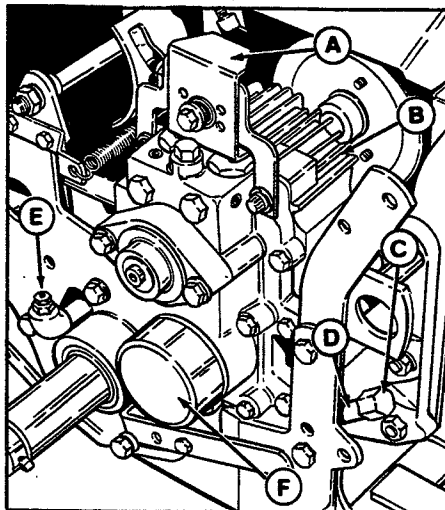

Figure 9. Hydrostatic Transmission

- A. Free Wheeling Latch
- B. Cooling Fins
- C. Fill Cap
- D. Fill Tube
- E. Relief Valve
- F. Filter

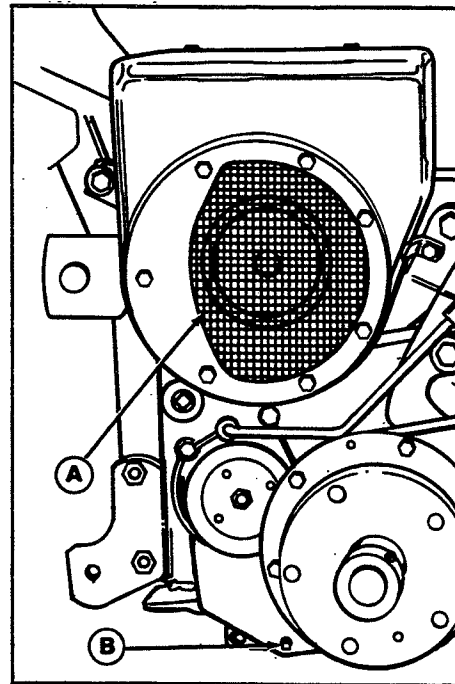

Figure 10. Hydrostatic Transmission

- A. Cooling Fan Screen
- B. Drain Plug

3. Clean dirt from the hydrostatic transmission filter and filter holder into which it is mounted and remove and discard filter.
4. When fluid has drained out of transmission, install new hydrostatic transmission filter in the following way:
Fill the filter with new fluid. Coat gasket with transmission fluid, screw filter on until gasket contacts base, then tighten 1/2 to 3/4 turn more. Use no tools. Turn by hand only. Install and tighten drain plug securely.
5. Remove the fill cap (C, figure 9) and clean dirt away from the relief valve (E). Using a clean funnel, add Simplicity Multi-Purpose Hydraulic/Transmission Oil, Type F transmission fluid, or Deutz-Allis Power Fluid 821 into the fill tube while holding the relief valve up until fill tube will accept no more fluid. Replace the fill tube hand tight.

NOTE

Vent rod must be held fully up for the entire time that fluid is being added.

6. Start engine and set it at idle speed, or slightly above.

 **CAUTION**

Make sure that free wheeling latch is firmly down and that parking brake is fully engaged before starting the engine.

7. Let engine run at least five minutes, then stop engine and immediately lift relief valve and remove fill tube cap. While relief valve is up, pour more fluid into the transmission fill tube until level reaches the "run-over" point of the tube. Then install and tighten the fill tube cap. Total fluid installed should be three quarts or more. Be extremely careful to keep all dust and dirt out of transmission while changing oil and filter. Check filter and drain plug for leaks.

ADD GREASE TO PLANETARY GEAR ASSEMBLY — SEMI-AUTOMATIC

1. With tractor engine off, key removed, and parking brake set, pry off cover cap (D, figure 11) carefully with a screwdriver.

2. Work No. 2 Lithium grease into planetary assembly with hand. Be sure no dirt enters the grease or planetary assembly. Also fill the cap half full with grease.
3. Replace the cap and tap it in place.
4. Apply a small amount of grease to the pin groove of the drive brake detent (C) and to the head of the bolt (B) that actuates the interlock safety switch (A).

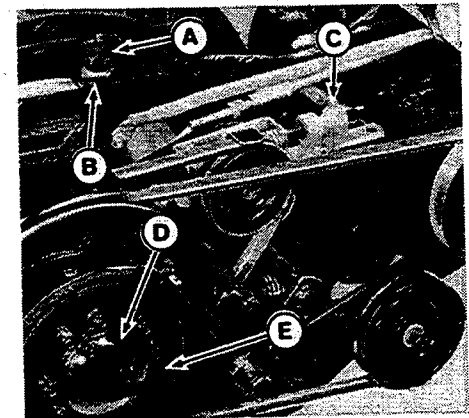

Figure 11. Planetary Gear - Semi-Automatic

- | | |
|-----------------------------------|--------------------------|
| A. Interlock Safety Switch | D. Cover Cap |
| B. Switch Actuating Bolt | E. Planetary Gear |
| C. Brake Detent | |

LUBRICATE MOWER IDLER PULLEY PIVOT

1. Remove mower from tractor.
2. Remove cotter pins to fold back the adjusting rods (42" mower) or lift the bail assembly (48" mower).

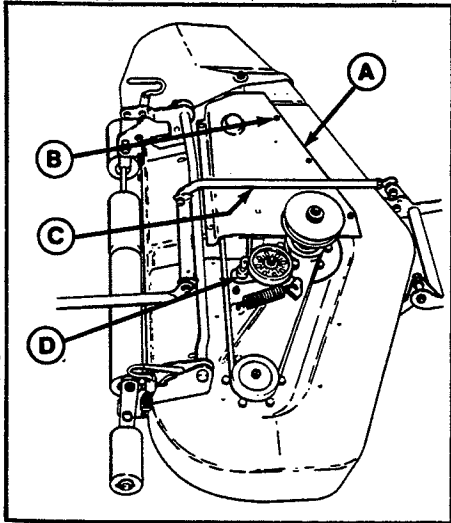

Figure 12. Idler Pulley Pivot

- A. Cover
B. Taptites
C. Level Adjusting Rod
D. Idler Pulley Pivot

3. Remove the taptite screws to remove the right hand cover (both covers can be removed to check/clean inside of mower deck). See figure 12.
4. Apply a few drops of oil to idler pulley pivot. Be sure idler pivots freely.
5. Reinstall cover and taptite screws. Be sure the belt fits inside the belt guide which is located on bottom of cover.
6. Reinstall adjusting rods or bail assembly and secure with cotter pins. Be sure to spread legs of cotter pins.

CLEAN, SHARPEN & BALANCE BLADES

1. Remove mower from tractor.
2. Check each of the three blades. Blades should be sharp and free of nicks and dents. If not, sharpen blades as described in remaining steps.



WARNING

For your personal safety, do not handle the sharp mower blades with bare hands. Careless or improper handling of blades may result in serious injury.

3. To remove blade for sharpening, use wooden block to hold blade while removing its blade mounting capscrew (figure 13).

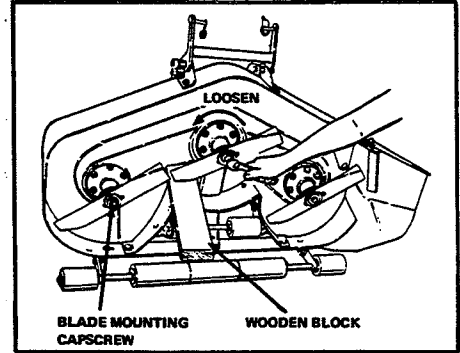

Figure 13. Loosen Blade

4. Use a file to sharpen blade to fine edge. Remove all nicks and dents in blade edge. If blade is severely damaged, it should be replaced.

5. Balance the blade as shown in figure 14. Center the blade's center hole on a nail lubricated with a drop of oil. A balanced blade will remain level.

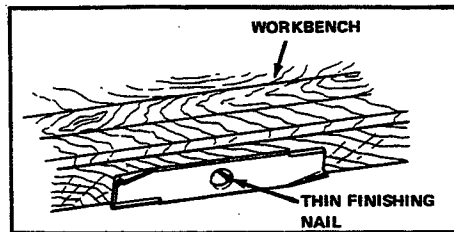

Figure 14. Balance Blade



WARNING

For your personal safety, blade mounting capscrews must be installed with the cup washer and spline washer and then securely tightened. Torque blade mounting capscrews to 45 to 55 ft. lbs. (61 to 74.6 N.m).

6. Reinstall each blade with the tabs pointing up toward deck and secure with a capscrew, cup washer, and spline washer. Be sure spline washer is aligned with shaft splines. Use a wooden block to prevent blade rotation (figure 15) and torque capscrews from 45 to 55 ft. lbs. (61 to 74.6 N.m).

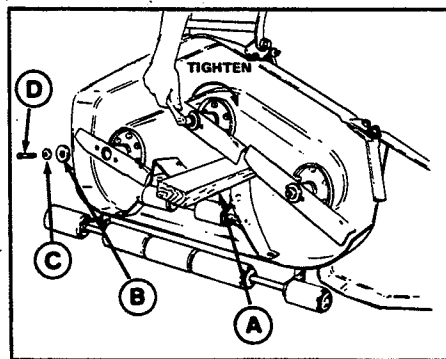

Figure 15. Install Blade

- A. Wooden Block
 B. Spline Washer
 C. Cup Washer
 D. Capscrew

Storage

STORAGE (TWO MONTHS OR MORE)

1. Prepare the mower for storage as follows:
 - a. Remove mower from tractor.
 - b. Clean underside of mower.
 - c. Coat all bare metal surfaces with paint or light coat of oil to prevent rusting.
 - d. Clean, sharpen and balance the blades.
2. Either add a gasoline stabilizer to the tank or drain the tank. Drain tank as follows.
 - a. Disconnect the fuel line from the carburetor or fuel pump. Drain fuel. Reconnect fuel line and put about 1/2 cup gasoline back into tank. Wipe up any spills.
 - b. Start engine and allow it to run until all gasoline is used up and engine stops.

Drain crankcase oil while engine is hot and refill with a grade of oil that will be required when tractor is used again.

3. Remove spark plug. Pour one ounce of 10W-30 oil into engine through spark plug hole. Crank engine a few times to distribute oil and then reinstall the spark plug.
4. Clean any dirt or grass from cylinder head cooling fins and engine housing and clean air cleaner element.
5. Cover air cleaner and exhaust outlet tightly with plastic or other water proof material to keep moisture, dirt and insects out of the engine.
6. Completely lubricate tractor as outlined in earlier part of this section.
7. Clean up tractor and apply paint or rust preventive to any areas where paint is chipped or damaged.
8. Be sure the battery is filled to the proper level with water and is fully charged. Battery life will be increased if it is removed and put in a cool, dry place and fully charged about once a month.
9. If the tractor is to be stored 6 months or longer block the tractor up off the wheels to relieve weight and keep the tires off a damp floor. Protect the tires

from prolonged exposure to direct sunlight.

10. Store the tractor in a dry place indoors.

STARTING AFTER STORAGE

Before starting the tractor after it has been stored, do the following:

1. Remove the blocks from under the tractor.
2. Replace the battery.
3. Unplug the exhaust outlet.
4. Remove spark plug and wipe it dry. Crank the engine a few times to blow excess oil out of the plug hole. Reinstall plug.
5. Fill fuel tank with fresh regular grade gasoline.
6. Check crankcase oil level, and add proper oil if necessary.
7. Inflate tires to proper operating pressure. Check fluid levels.
8. Start the engine and let it run slowly. **DO NOT** run at high speed immediately after starting. Be sure to run engine only out of doors or in well ventilated area.

Troubleshooting & Belt Replacement

For problems not covered in this manual, contact your dealer.



WARNING

Before performing maintenance, lower the attachment, shut off engine and remove key, disengage power to attachments, set parking brake, and shift transmission into gear (for hydrostatic tractor, shift into forward range).

1. Engine does not crank.

- A. Semi-Automatic or Six Speed - Gear shift lever not in neutral.
Hydrostatic - Transmission control lever not in neutral.
- B. PTO lever(s) not disengaged.
- C. Circuit breaker tripped. Wait one minute for automatic reset. If defective, see your dealer.
- D. Wiring loose or broken. Replace broken wires and tighten connections.
- E. Battery discharged or terminals corroded. Clean terminals or have battery charged.
- F. Faulty electrical system.

2. Engine cranks but does not start.

- A. Out of gasoline.
- B. Engine flooded. Push in choke and attempt to start.
- C. Crankcase oil too heavy. See Engine Manual.
- D. Water in gasoline or gasoline is stale. Drain and fill with fresh gasoline.
- E. Faulty engine electrical or fuel system. See Engine Manual or your dealer.

3. Engine hard to start or runs poorly.

- A. Fuel mixture too rich. Push in choke. Clean air filter.
- B. Carburetor adjusted incorrectly or engine needs tune up. See Engine Manual or your dealer.
- C. Water in gasoline. Drain and fill with fresh gasoline.

4. Engine knocks.

- A. Oil level low. Add oil as required.
- B. Wrong grade of oil. See oil specifications.
- C. Wrong grade of gasoline. Use fresh, regular grade of gasoline.

5. Excessive oil consumption.

- A. Engine running too hot. Clean engine cooling fins and blower screen.
 - B. Wrong weight of oil. See oil specifications.
 - C. Too much oil in crankcase. Drain excess oil.
-

6. Exhaust black or smoky.

- A. Dirty air filter. Clean or replace.
 - B. Choke not open. Push in choke and be sure choke plate opens.
 - C. Carburetor adjustment wrong. See Engine Manual or your dealer.
-

7. Semi-Automatic Tractor - Tractor creeps forward or backward with vehicle motion lever in neutral. Perform neutral adjustment.

8. Hydrostatic Tractor - Tractor creeps forward or backward with hydrostatic control lever in neutral position. Perform hydrostatic neutral adjustment.

9. Engine runs, but will not drive tractor or lacks power.

- A. **Semi-Automatic or Six Speed** - Transmission not in gear; shift into gear. Drive clutch out of adjustment; adjust.
 - B. **Hydrostatic** - Free wheeling latch down; push latch up. Hoses kinked; check and correct. Clutch idler pivot sticking; lubricate.
 - C. Parking brake engaged.
 - D. Transmission oil cold. Allow three minutes for warmup.
 - E. Transmission fluid low. Add as required. Check for leaks.
 - F. Drive belt slipping. See problem no. 10.
-

10. Drive belt slips.

- A. Clutch free travel or belt tension out of adjustment. Adjust.
 - B. Pulleys or belts greasy or oily. Clean.
 - C. Clutch rod binding in guide; oil clutch rod.
 - D. Belt stretched or worn. Replace belt.
-

11. Brake will not hold.

- A. Brake (foot pedal or parking) out of adjustment.
- B. Brake lining worn. Replace.

12. Tractor handles poorly.

- A. Steering linkage loose. Tighten any loose connections.
- B. Improper tire inflation.
- C. Wheels spinning or slipping. Use weights.
- D. Driving too fast for land contours. Reduce speed.
- E. Steering requires lubrication.

TROUBLESHOOTING (MOWER)

1. Mower will not raise.

- A. Lift cable not attached or broken. Attach or replace as necessary.
- B. Lift lever or electric lift problem. See your dealer.
- C. Hydraulic lift system faulty. See your dealer.

2. Mower cut is uneven.

- A. Mower not leveled properly. Perform "Mower Levelling", page 45.
- B. Tractor tires not inflated properly. See tractor manual for correct pressures.
- C. Missing pin on mower hitch. Install pin.

3. Mower cut is rough looking.

- A. Engine speed too slow. Use 3/4 to full throttle.
- B. Tractor ground speed too fast. Use low gear or slower tractor ground speed.
- C. Blades dull and require sharpening.
- D. Mower drive belt oil or worn. Clean or replace belt as necessary.
- E. Mower idler pulley pivot sticking. Check/lubricate as necessary (See Normal Care).
- F. Mower internal drive belt worn or broken.

4. Engine stalls easily with mower engaged.

- A. Tractor ground speed too fast. Use low gear or slower tractor ground speed.
- B. Engine speed too slow. Use 3/4 to full throttle.
- C. Cutting height set too low when mowing tall grass. Cut tall grass at maximum cutting height during first pass.
- D. Discharge chute jamming with cut grass. Mow grass with discharge pointing toward previously cut area or wait for drier conditions.

5. Excessive mower vibration.

- A. Blade mounting capscrews are loose. Torque capscrews to 45-55 ft. lbs. (61 to 74.6 N.m).
- B. Mower blades are bent. Replace.
- C. Mower blades are out of balance. Remove, sharpen & balance blades (page 22).

6. Excessive belt breakage occurs.

- A. Loose or rough pulleys. File off rough edges or replace as necessary.
- B. Incorrect belt. Use belt designed for your mower.
- C. Damaged mower pulley. See your dealer.
- D. Mower not levelled properly. Level the mower.
- E. Operating mower with lift lever in raised position. Operate mower only with lift lever in lowered position.
- F. Belt out of adjustment. See "Mower Installation" procedure.

7. Belt slips.

- A. Pulleys or belt greasy or oily. Clean.
- B. Belt stretched. Replace belt.
- C. Belt out of adjustment. See "Mower Installation" procedure.

BATTERY REPLACEMENT

A dead battery or one too weak to start the engine may not mean the battery needs to be

replaced. It may, as an example, mean that the alternator is not charging the battery properly. If there is any doubt about the

cause of the problem, see your dealer. If you need to replace the battery, proceed as shown in the battery cleaning procedure (page 18).

JUMP START WITH AUXILIARY (BOOSTER) BATTERY

Jump starting is not recommended. However, if it must be done, follow these directions. Both booster and discharged batteries should be treated carefully when using jumper cables. Follow exactly the procedure outlined below, being careful not to cause sparks.



WARNING

For your personal safety use extreme care when jump starting. Never expose battery to open flame or electric spark — battery action generates hydrogen gas which is flammable and explosive. Do not allow battery acid to contact skin, eyes, fabrics, or painted surfaces. Batteries contain a sulfuric acid solution which can cause serious personal injury or property damage. Also note the close proximity of battery and gas tank.

1. Set parking brake and place transmission in "NEUTRAL". Turn off lights and other electrical loads.
2. Remove vent caps from both the booster and the discharged batteries. Lay a cloth over the open vent wells of each battery. These two actions help reduce the explosion hazard always present in either battery when connecting a "live" battery to a "dead" battery.

3. Attach one end of one jumper cable to the positive terminal of the booster battery (identified by a red color, "+" or "P" on the battery case, post or clamp) and the other end of same cable to positive terminal of discharged battery. DO NOT permit vehicles to touch each other, as this could establish a ground connection.

4. Attach one end of the remaining cable to the negative terminal (black color, "-" or "N") of the booster battery, and the other end to a bare metal surface on the frame of your tractor AWAY FROM the battery compartment (do not connect directly to negative post of dead battery). Take care that clamps from one cable do not inadvertently touch

the clamps on the other cable. Do not lean over the battery when making this connection.

5. The tractor with the dead battery should now start.

Reverse the jump starting procedure exactly to remove the jumper cables. Then reinstall the vent caps and throw the cloths away as they may have corrosive acid on them.



WARNING

Any procedure other than the above could result in: (1) personal injury caused by electrolyte squirting out the battery vents, (2) personal injury or property damage due to battery explosion, (3) damage to the charging system of the booster vehicle or of the immobilized vehicle.

Do not attempt to jump start a vehicle having a frozen battery because the battery may rupture or explode. If a frozen battery is suspected, examine all fill vents on the battery. If ice can be seen or if the electrolyte fluid cannot be seen, do not attempt to start with jumper cables as long as the battery remains frozen.

DRIVE BELT REPLACEMENT — SEMI-AUTOMATIC

1. Raise the tractor seat.
2. Remove the two taptite screws to remove the transmission pulley belt retainer (A, figure 16).

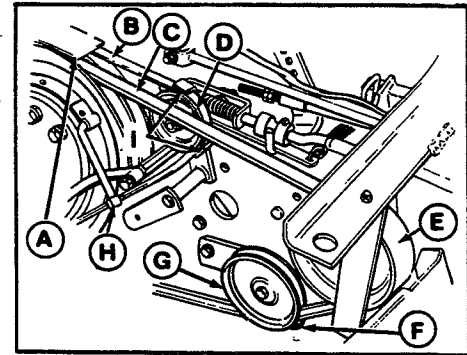

Figure 16. Drive Belt Replacement - Semi-Automatic

- | | |
|-------------------------|------------------|
| A. Pulley Belt Retainer | F. Guide Finger |
| B. V-Belt | G. Idler Pulley |
| C. Main Drive Belt | H. Pivot Rod |
| D. Pulley | I. Guide Fingers |
| E. Belt Guard | |

- Loosen, but do not remove, the hex nut holding the idler pulley (G).
- Loosen or remove the belt guard (E) at the front pulley.
- Disengage the clutch to put slack in the main drive v-belt (C). Remove the main drive belt from the large rear pulley first and then from the other pulleys.
- Remove the spring clip holding the pivot rod assembly (H), and pull the pivot rod free as shown.
- Loosen the hex nut at the small pulley (D). Then place the shuttle control lever in REVERSE to put slack in the belt, and remove the shorter v-belt (B).
- Install new v-belts designed for your machine. Remember: the shorter belt (B) must be installed first.
- Engage the clutch and place the shuttle control lever in FORWARD to tension the belts. Check to be sure the belts are seated in all pulley grooves.
- Position the two belt guide fingers (I) on the small pulley (D) about 1/8 inch (3 mm) from the pulley. Hold the guide in position and retighten the hex nut to hold the small pulley.
- Reinstall the pulley belt retainer (A) with the two taptite screws. Position the retainer so there is 1/16 to 1/8 inch (1.5 to 3 mm) clearance between the retainer and all points of both drive pulleys. Hold the retainer in place and tighten the screws.
- Return the shuttle control lever to its neutral notch. Reinstall the pivot rod (H) and secure it with the spring clip.
- Tighten the hex nut to hold the idler pulley (G) in place. Be sure the belt guide finger (F) traps the belt in the idler pulley as shown.
- Position the belt guard (E) so there is 1/16 to 1/8 inch clearance between the guard and all points of the pulley. Hold the guard in position and tighten the hex nut to secure the guard.

DRIVE BELT REPLACEMENT — HYDROSTATIC

- Tie the clutch-brake pedal down in the disengaged position.
- Raise the tractor seat deck.
- Remove the capscrew (C, figure 17) and remove the belt guard assembly (B).

- Remove the two capscrews (D) and the thread forming screw (E) to remove the fan guard assembly.

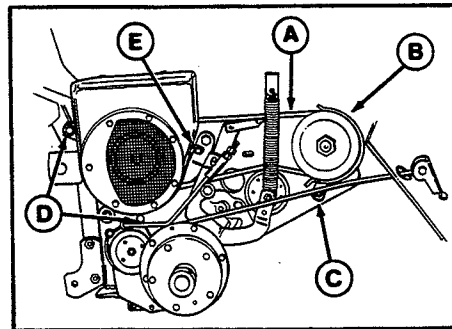

Figure 17. Drive Belt Replacement - Hydrostatic

- A. Belt** **D. Fan Guard Capscrews**
B. Belt Guard **E. Thread Forming Screw**
C. Capscrew

- Remove the old belt and install the new one. Make sure the belt is in all pulley grooves and is not twisted.
- Reinstall the fan guard with the capscrews (D) and the thread forming screw (E).
- Release the clutch-brake pedal and check to be sure belt is still seated in all pulleys.

8. Reinstall the belt guard (B) so the bracket on the back side almost touches the pulley hub. Hold the guard in place and tighten the capscrew (B).
9. Check and adjust the tractor clutch according to the instructions in the Adjustment section.
10. Lower and latch the seat deck when finished.

DRIVE BELT REPLACEMENT — SIX SPEED

1. Place speed range lever in HI position.
2. Raise tractor seat.
3. Remove the cotter pin (B, figure 18) from the brake rod (A). Then remove the inner drive belt from inside the brake rod bracket.
4. Remove the capscrew with lockwasher (H) holding the bottom of the transmission pulley belt retainer (I).
5. Remove the taptite screw (J) holding top of belt retainer, and slide the belt retainer and brake rod assembly out the rear of the tractor.
6. Remove the taptite screw (D) from

bottom of front pulley belt guard.

7. Remove the taptite screw (C) from top of front pulley belt guard, and remove the guard.
8. Remove the outside v-belt (F) from the front pulley first, and then off the tractor.
9. Depress the clutch-brake pedal to slacken the inner v-belt (G) and remove from the idler pulley (E) and off the tractor.
10. Reinstall the new v-belts in the reverse order of their removal. Make sure both belts are properly seated in all pulley grooves.

To reassemble your tractor, proceed as follows:

1. Reinstall the belt retainer (I) with the taptite screw and the capscrew and lockwasher (J and H). Align the belt retainer so it is 1/16 to 1/8 inch (1.5 to 3 mm) from all points of the transmission pulleys before tightening hardware.
2. Reinstall the brake rod (A) in the lever and secure it with a cotter pin (B). Slip the inner v-belt back inside the brake rod bracket.

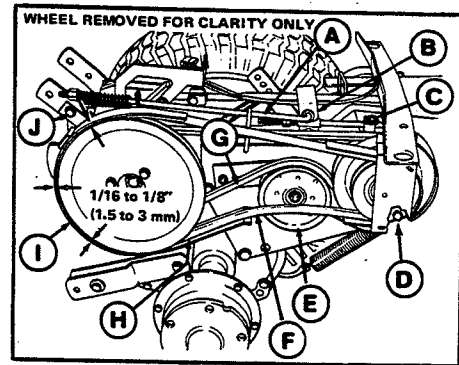

Figure 18. Replacing Drive Belts

- | | |
|------------------|--|
| A. Brake Rod | H. Capscrew and Lockwasher (Behind Pulley) |
| B. Cotter Pin | I. Transmission Pulley Belt Retainer |
| C. Taptite Screw | J. Taptite Screw |
| D. Taptite Screw | |
| E. Idler Pulley | |
| F. V-Belt | |
| G. V-Belt | |

3. Reinstall the front pulley belt guard with the two taptite screws (C and D).
4. Check pulley brake and readjust as necessary according to the Adjustment section of this manual.

MOWER BELT REPLACEMENT

1. Remove mower from tractor as instructed in "Mower Removal" (page 46).
2. Remove the self-tapping screws from the covers. The 42 inch mower has 10 screws. The 48 inch mower has 14 screws.
3. For the 42 inch mower, remove the cotter pin and pull back the right-hand levelling bar (D). Lift the right-hand belt cover over the lift anchor. Remove the left-hand cover.
4. For the 48 inch mower, lift the bail assembly slightly to provide access for cover removal. Remove the left-hand belt cover first. Then spring the inner edge of the right-hand belt cover up over the lift anchor (G) and slide it out from under the levelling rod.
5. Clean the interior of the mower belt housing.
6. The idler pulley arm pivots at the lift anchor. Make sure the arm pivots freely. Lubricate the pivot with a drop or two of oil and wipe up excess oil.

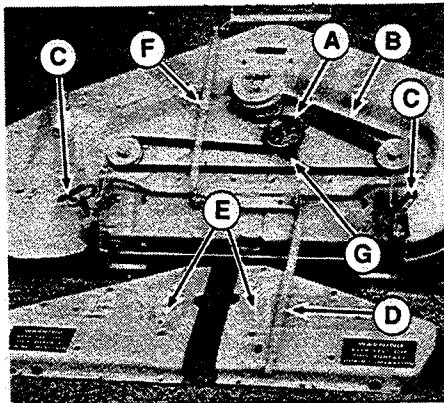

Figure 19. Mower Drive Belt -
42 Inch Mower Shown

- A. Idler Pulley
- B. Mower Belt
- C. Height Adjusting Lever
- D. Leveling Bar, RH
- E. Belt Covers
- F. Leveling Bar, LH
- G. Lift Anchor

7. Unhook the idler spring (B) from the idler (A). Remove the old belt from the pulleys. Install the new belt and re-attach idler spring (B).
8. Reinstall the belt covers and connect the levelling bars. Be sure to spread cotter pin legs fully. When installing the right-hand belt cover, be sure the belt is positioned in the belt guide which is located on bottom of belt cover.

Adjustments



WARNING

Before performing maintenance, lower the attachment, shut off engine and remove key, disengage power to attachments, set parking brake, and shift transmission into gear (for hydrostatic tractor, shift into forward range).

RAISING THE SEAT DECK — ALL MODELS

Reach under the seat deck and locate the locking levers (one on each side). Press upward at the tips of both levers and raise the seat deck.

SEAT ADJUSTMENT — ALL MODELS

1. Lift up the seat as shown in figure 20.
2. Loosen the four capscrews under the seat and slide the seat forward or back. Tighten the capscrews firmly.
3. The springs (B) can be moved to different holes in the deck for maximum riding comfort. A lighter person will want to

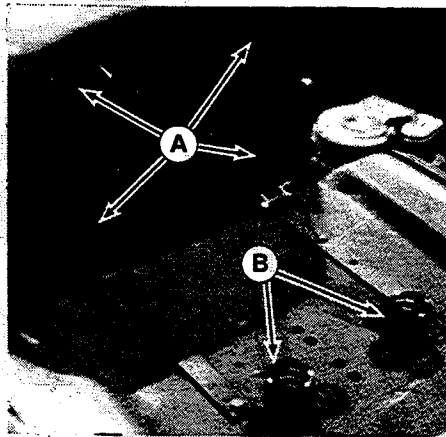

Figure 20. Seat Adjustment

A. Nuts B. Springs

move the springs more forward. To change position, lift the springs and move to desired holes.

PTO CLUTCH ADJUSTMENT — ALL MODELS

The PTO clutch is properly adjusted when the clutch pulley (C, figure 21) moves away from clutch cone (D) 1/16 inch (1.5 mm) when clutch is disengaged. To adjust, proceed as follows.

1. Loosen the rear nut (B).

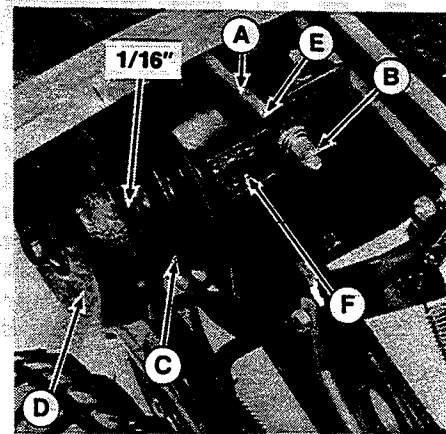

Figure 21. PTO Clutch Adjustment - All Models

A. PTO Clutch Rod D. Clutch Cone
B. Jam Nuts E. Locknut
C. Clutch Pulley F. Pivot Arm

2. Turn the front nut slightly clockwise to increase pulley travel or counterclockwise to decrease pulley travel.
3. Tighten the rear nut against the front nut and repeat the check.
4. Adjust locknut (E) so there is 1/8" between locknut (E) and pivot arm (F) when clutch is disengaged.

ADJUSTMENTS — HYDROSTATIC

1. To adjust parking brake, loosen the jam nut (E, figure 22) at parking brake rod end. Rotate the parking brake handle (B) clockwise until it is tight and pulled up against fender as shown. Operate the brake handle to see if it is too loose or too tight. It should be tight against fender when set but not too tight to operate. When proper adjustment is made, tighten the jam nut.
2. To adjust the foot brake, engage the parking brake. Adjust jam nuts (H) on end of foot brake rod to provide 1/2 inch (12.7 mm) spring length between washers. (If not equipped with spring, see following note.) Depress the pedal to engage the brake. The drive belt should be slack and free of idler pulley. If not, check clutch adjustment (step 3). Test operate the tractor. If brake doesn't stop the tractor, see your dealer.

NOTE

In step 2, on early models that are not equipped with spring (M, figure 22) adjust nuts (H) to achieve 1/2" clearance to rod guide (G). In step 3, adjust jam nuts (J) to achieve 3/8" clearance to rod guide.

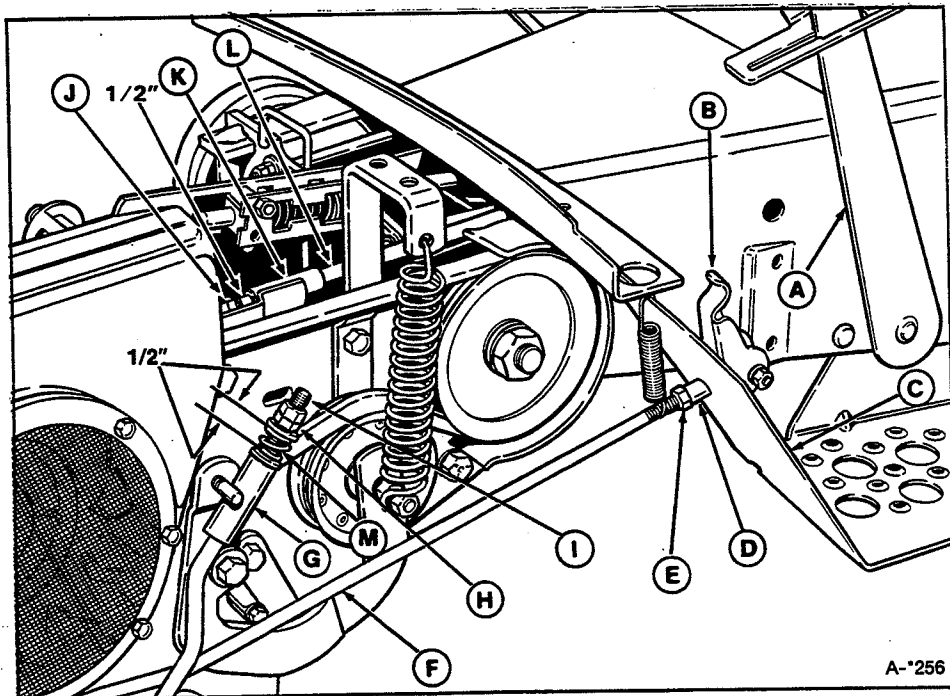

A-256

Figure 22. Brake & Clutch Adjustments - Hydrostatic

A. Hydrostatic Control Lever
 B. Parking Brake Handle
 C. Fender
 D. Parking Brake Rod End
 E. Jam Nut
 F. Parking Brake Rod

G. Foot Brake Rod Guide
 H. Jam Nuts
 I. Foot Brake Rod
 J. Jam Nuts
 K. Clutch Rod Guide
 L. Clutch Rod

M. Spring

3. To adjust tractor clutch, adjust jam nuts (J) on clutch rod so there is 1/2 inch spring length between washers with clutch-brake pedal in up position. (If not equipped with spring, see previous note.)
4. **Hydrostatic Neutral Adjustment.** If the tractor creeps forward or back when the hydrostatic control lever is in neutral, adjust as follows.

**CAUTION**

Always stop engine before leaving operator's position. Do not perform adjustment with engine running.

- a. Park tractor on level ground, make sure hydrostatic control lever is firmly seated in the neutral notch of quadrant, stop engine and set parking brake.
- b. Raise the seat deck and check if the pump control arm roller (E, figure 23) is exactly centered with the centering mark (D). If not, loosen bolt (C) and move the control cam (B)

until centering mark (D) is centered on roller (E). Tighten the bolt (C).

- c. Lower the seat deck, get in operator's seat, start engine and release parking brake. If tractor still creeps with hydrostatic control lever in neutral, note which direction it creeps and proceed with next steps.
- d. Stop the engine, set parking brake, and raise seat deck. Loosen the jam nut (H) on end of cam pivot shaft (G). If tractor creep had been in reverse turn adjusting nut (I) 1/8 to 1/4 turn clockwise when viewed from right side of tractor. If tractor creep had been forward, turn nut 1/8 to 1/4 turn counterclockwise. Lock jam nut, lower seat deck, get in operator's seat, start engine, and release parking brake. If tractor still creeps, repeat step "d" turning nut (I) a little at a time until no creep occurs.

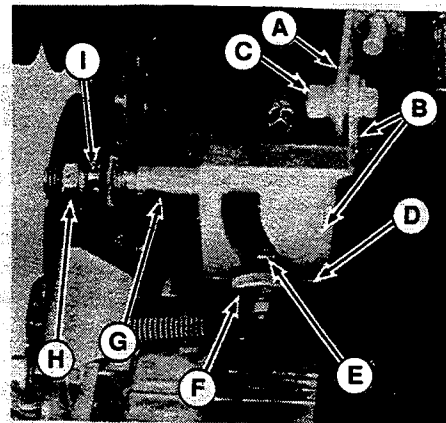

Figure 23. Hydrostatic Neutral Adjustment

- A. Control Strap
- B. Control Cam Assy.
- C. Bolt
- D. Centering Mark
- E. Pump Control Arm Roller
- F. Pump Control Arm
- G. Cam Pivot Shaft
- H. Jam Nut
- I. Adjusting Nut

ADJUSTMENTS — SEMI-AUTOMATIC

1. To adjust parking brake, loosen the jam nut (F, figure 24) at parking brake rod end. Rotate the parking brake lever (H) clockwise until it is tight and pulled up against fender as shown. Operate the lever to see if it is too tight or too loose. It should be tight against fender when set but not too tight to operate. When proper adjustment is made, tighten the jam nut.
2. To adjust tractor clutch, adjust jam nuts (J, figure 25) on the clutch rod so there is 1/4 inch (6 mm) clearance between jam nut and rod guide (K) with clutch-brake pedal in up position.

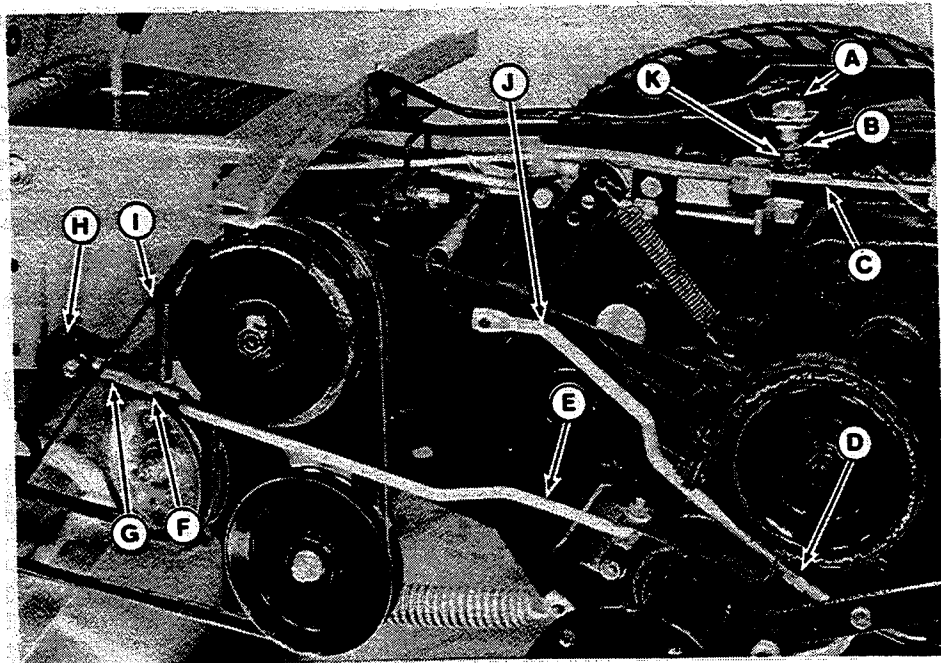

Figure 24. Semi-Automatic

- | | |
|----------------------|------------------------|
| A. Interlock Switch | G. Rod End |
| B. Locknut | H. Parking Brake Lever |
| C. Gear Shift Rod | I. Fender |
| D. Jam Nuts | J. Brake Rod |
| E. Parking Brake Rod | K. Carriage Bolt |
| F. Jam Nut | |

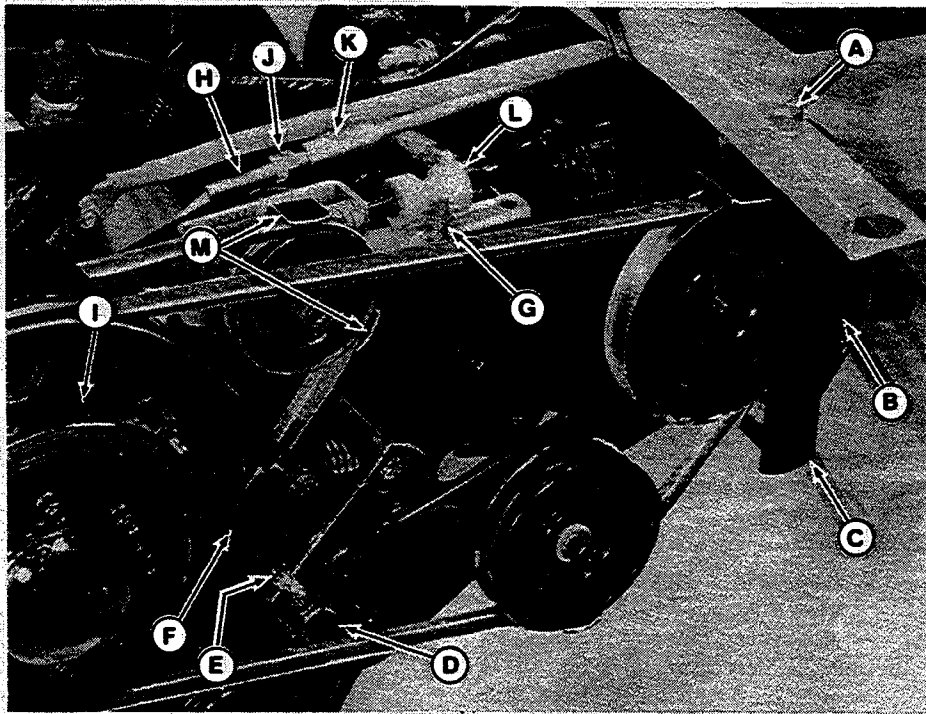

Figure 25. Semi-Automatic Tractor Adjustments

- | | | |
|---------------------|---------------|---------------------|
| A. Bolt | E. Lock Pin | I. Brake Band |
| B. 1/8" Clearance | F. Brake Rod | J. Jam Nuts |
| C. Front Belt Guard | G. Brake Pin | K. Clutch Rod Guide |
| D. Pivot Pin | H. Clutch Rod | L. Brake Detent |
| | | M. Belt Stops |

- To adjust the foot brake, adjust jam nuts (D) on the brake rod so that the clutch-brake pedal will stop the tractor, but not so tight that brake drags or prevents proper clutch disengagement. Turning nuts (D) clockwise will give more braking action and turning counterclockwise will give less. Use the trial and error method and operate the tractor after each adjustment is made. Tighten the jam nut against the adjusting nut after adjustment is made.

**Semi-Automatic Adjustments Continued
On Next Page**

4. **Neutral Adjustment.** If the tractor creeps forward or backward when the vehicle motion lever is in neutral or if tractor will not drive with full power or if gears grind when shifting, perform adjustment as follows.

- a. Place the vehicle motion lever in its neutral position.
- b. Check that the brake pin (C, figure 26) is centered in notch of brake detent spool (B). If not, loosen setscrew in brake detent spool and slide detent spool to center brake pin in notch. Tighten the setscrew.
- c. Place the vehicle motion lever in forward drive position. There should be 1/8 inch (3 mm) clearance between brake pad and drive pulley (figure 27). If not, loosen nut turn brake pad in or out until clearance is reached. Retighten nut.

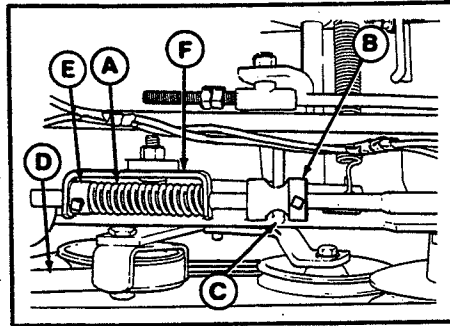

Figure 26. Neutral Adjustment

- A. Forward Drive Belt Spring
- B. Brake Detent Spool
- C. Brake Pin
- D. Forward Drive Belt
- E. Set Collar
- F. Rod Guide

- d. Place vehicle motion lever in forward drive position. Make sure the distance between rod guide (A, figure 28) and set collar (C) is 1/8 to 3/16 inch (3 to 5 mm). If not, place shuttle control in neutral, loosen setscrew, and move set collar (C) and guide (A) forward to increase the distance or back to decrease clearance. Retighten the setscrew. Shift into forward drive and recheck adjustment.

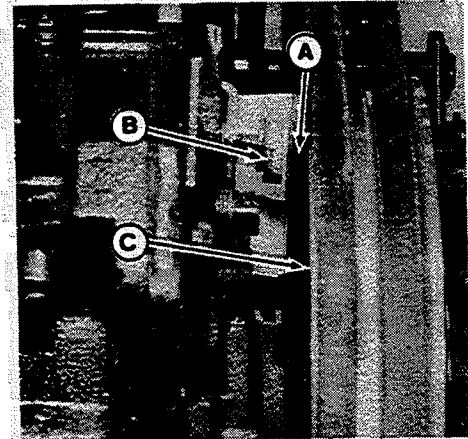

Figure 27. Neutral Adjustment

- A. 1/8" Clearance
- B. Brake Pad
- C. Pulley

- e. Place vehicle motion lever in forward drive position. Make sure the clearance between the forward drive belt and each leg of the belt stop (M, figure 25) is 1/16 to 1/8 inch (1.5 to 3 mm). If not, loosen the nut on other side of pulley just enough so that the belt stop can be rotated. When adjustment is correct, retighten the nut.

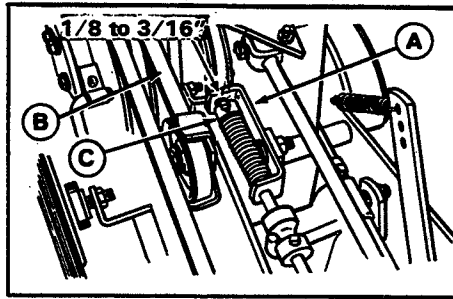

Figure 28. Neutral Adjustment

- A. Rod Guide
- B. Forward Drive Belt
- C. Set Collar

- f. Place vehicle motion lever in reverse drive position. The brake band (I, figure 25) should grip the planetary hub tightly. If not, place the vehicle motion in neutral position. Remove the spring clip (E) from the pivot pin (D) and pull the pivot pin out of its hole. Rotate the pivot pin on the rod so that almost all slack is taken out of the brake band when the pivot pin is in its hole and vehicle motion in neutral. Replace pivot pin in hole, and spring clip in pivot pin.

- g. Test operate the tractor. Another adjustment may be required. See the following guidelines.

Will not pull forward with full power. Repeat step d, placing more tension on the forward drive belt.

Tractor creeps forward when control lever is in neutral. Repeat step d, placing less tension on the forward drive belt.

Will not pull with full power in reverse. Repeat step f, putting more tension on brake band.

Tractor creeps rearward when control lever is in neutral. Repeat step f, putting less tension on the brake band.

Cannot shift gears without grinding when shuttle control lever is in neutral. Repeat steps b and c.

ADJUSTMENTS — SIX SPEED

1. To adjust the parking brake, loosen the jam nut (D, figure 29). Rotate the parking brake lever clockwise until it is tight and pulled up against fender. Operate the lever to see if it is too tight or too loose. It should be tight against fender when set but not too tight to operate. When proper adjustment is made, tighten the jam nut.

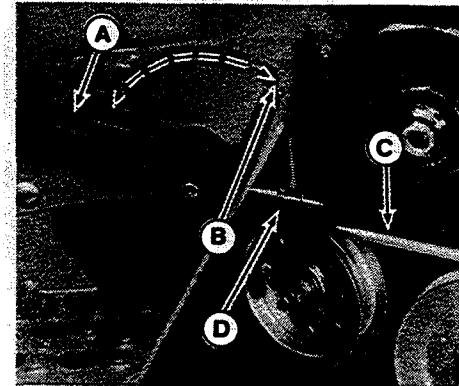

Figure 29. Parking Brake - Six Speed

- A. Parking Brake Lever
- B. Engaged Position
- C. Parking Brake Rod
- D. Jam Nut

Adjustments

2. To adjust the foot brake, depress the clutch-brake pedal and move the speed range lever until the cam lever (A, figure 30) is under the gate finger (B).

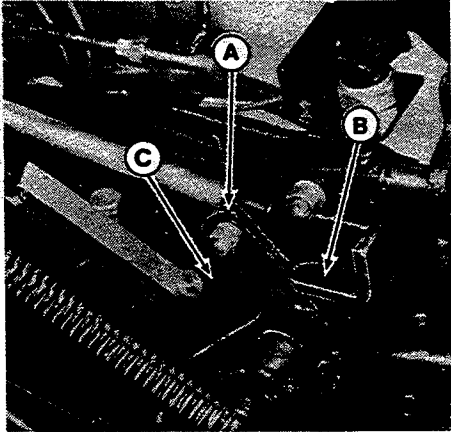

Figure 30. Foot Brake Adjustment - Six Speed

- A. Cam Lever
- B. Gate Finger
- C. 0.030" Feeler Gauge

Place a 0.030 inch feeler gauge between the cam lever and the end of the gate finger (figure 30). Release the brake pedal and set the parking brake. Loosen the brake rod jam nuts (figure 31). Turn

the front jam nut (B) in or out until it just comes in contact with the brake band plus 1/3 turn. Hold the front jam nut in position and tighten the rear jam nut securely.

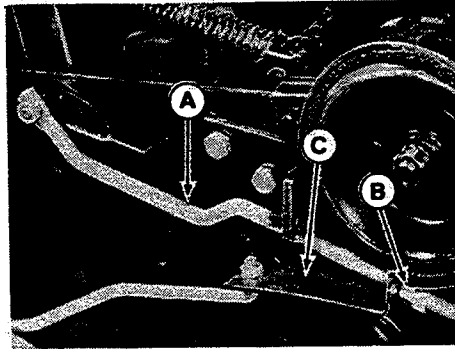

Figure 31. Foot Brake Adjustment - Six Speed

- A. Brake Rod
- B. Front Jam Nut
- C. Brake Band

3. Idler Pulley Arm Adjustment. This adjustment is necessary only if the idler pulley does not line up properly with the drive belt when the clutch is in the engaged position or if it binds on the

gate finger. If the idler pulley arm needs adjustment, proceed as follows:

- a. Push the speed range lever fully forward so that the idler arm is against the right rear sideplate.
- b. Loosen setscrew in hub of cam lever (B, figure 32).

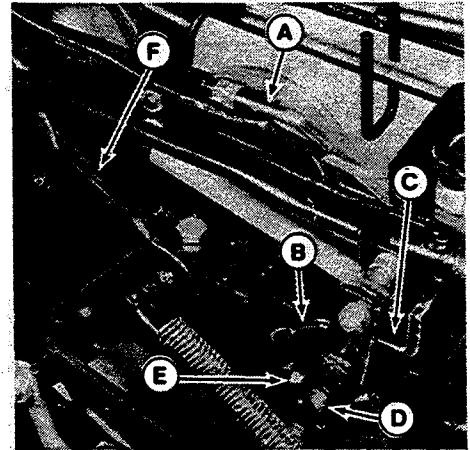

Figure 32. Idler Pulley Arm Adjustment - Six Speed

- A. Clutch-Brake Rod
- B. Cam Lever
- C. Gate Finger
- D. Idler Arm Shaft
- E. Setscrew
- F. Dual Range Control Rod

- c. With the idler arm against the right sideplate, move the cam lever so that it is flush against the left edge of the gate finger (C).
 - d. Tighten setscrew firmly in cam lever, depress clutch-brake and move speed range lever back and forth from Lo range to Hi range, checking that the cam lever does not bind on the gate finger.
4. **Rear Belt Retainer Adjustment.** The transmission pulley belt retainer should be adjusted so that there is 1/16 - 1/8 inch (1.5 - 3 mm) clearance between the edge of the retainer and the large outside pulley on the transmission. (See figure 33.) The retainer should follow the curve of the pulley evenly. If necessary, bend the retainer so that its edge follows the curve of the pulley evenly.

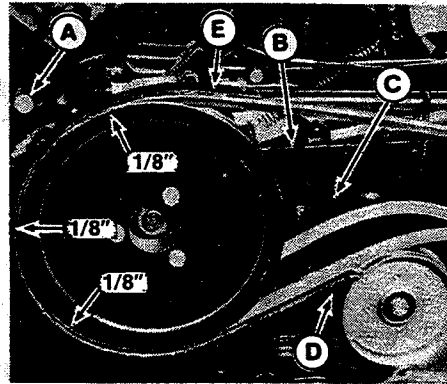

Figure 33. Rear Belt Guard Adjustment

- A. Belt Guard Capscrew
- B. Right Side Plate
- C. Sliding Idler Arm
- D. Belt Guard Capscrew

5. **Idler Tension Adjustment.** To check idler tension adjustment, place the speed range lever between Hi and Lo positions and release the clutch. Spring tension will hold the cam lever on the gate finger.
 - a. There should be 1/8 - 1/4 inch (3 to 6 mm) clearance between the outside belt and the top edge of the idler pulley, when the belt is resting on the

front and rear belt guards (A and C, figure 34).

- b. If there is not 1/8 - 1/4 inch clearance, loosen the nut holding on the idler pulley and move the pulley up or down as needed.
- c. When the proper clearance is reached, tighten the nut holding on the pulley firmly.

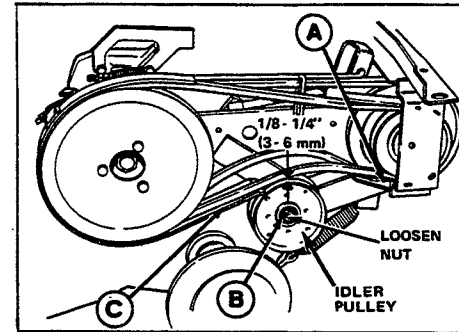

Figure 34. Idler Tension Adjustment - Six Speed

- A. Front Belt Guard
- B. Idler Adjusting Bolt
- C. Rear Belt Guard

6. Clutch Rod Clearance Adjustment.

- Shift the speed range lever to Hi, and release the clutch.
- Pull back firmly on the clutch rod (C, figure 35). There should be a $3/8$ inch (9.5 mm) gap between the clutch rod guide (A) and the clutch rod adjusting nut (B).

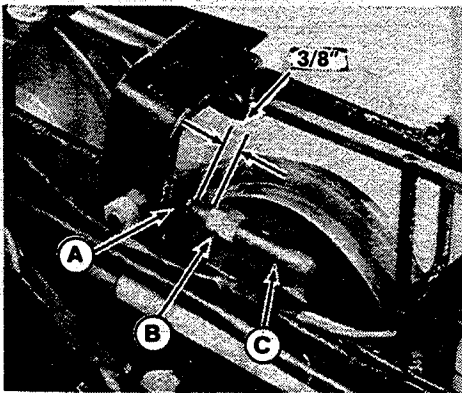

Figure 35. Clutch Rod Clearance Adjustment

- Rod Guide
- Adjusting Nut
- Clutch-Brake Rod

- If the clearance is not $3/8$ inch, loosen the locking nut from the adjusting nut, and turn the adjusting nut in or out to obtain the $3/8$ gap.
- When the proper gap is reached, hold the adjusting nut with a wrench and tighten the locking nut to it firmly.

7. Pulley Brake Adjustment.

- The pulley brake return spring (C, figure 36) should be compressed enough so that it measures $1-3/8$ inches (35 mm) with the clutch-brake pedal released (up). If it does not, turn the nut (D) to obtain the proper measurement.
- After adjusting the pulley brake return spring, press the clutch-brake pedal down fully to engage the brake.
- While holding the clutch-brake pedal down fully, measure the length of the rear spring (A) on the pulley brake rod. It should be compressed to $1-3/4$ inches (45 mm). If it is not $1-3/4$ inches, loosen the adjusting nut (B) and move it forward or back until the proper measurement is

reached. Then hold the adjusting nut and tighten the locking nut firmly to it.

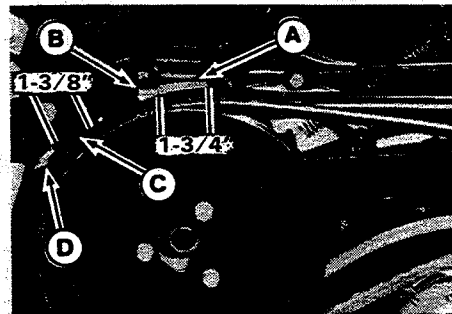

Figure 36. Pulley Brake Adjustment

- Spring, Pulley Brake Rod
- Adjusting Nut
- Rear Spring
- Locknut

MOWER INSTALLATION

- Place the mower on a flat, hard, surface. Park your tractor to the right of the mower, and position the tractor front wheels for a sharp right hand turn. Lower the attachment, shut off engine and remove key, disengage power to attachments, set parking brake, and shift transmission into gear (for hydrostatic tractor, shift into forward range).



WARNING

On tractors with hydrostatic lift, it will be necessary to start the engine to raise or lower the lift cable. Before starting the engine, always seat yourself in operator's position. Before leaving operator's position, shut off the engine, remove the key and wait for moving parts to stop.

- Make sure the front idler pulley (L, figure 37) is installed in top mounting tab for mower installation.
- If the tractor has a manual lift lever or the optional electric lift, lower the lift cable and go on to step 4. If the tractor has hydraulic lift, use the following procedure to lower the cable.

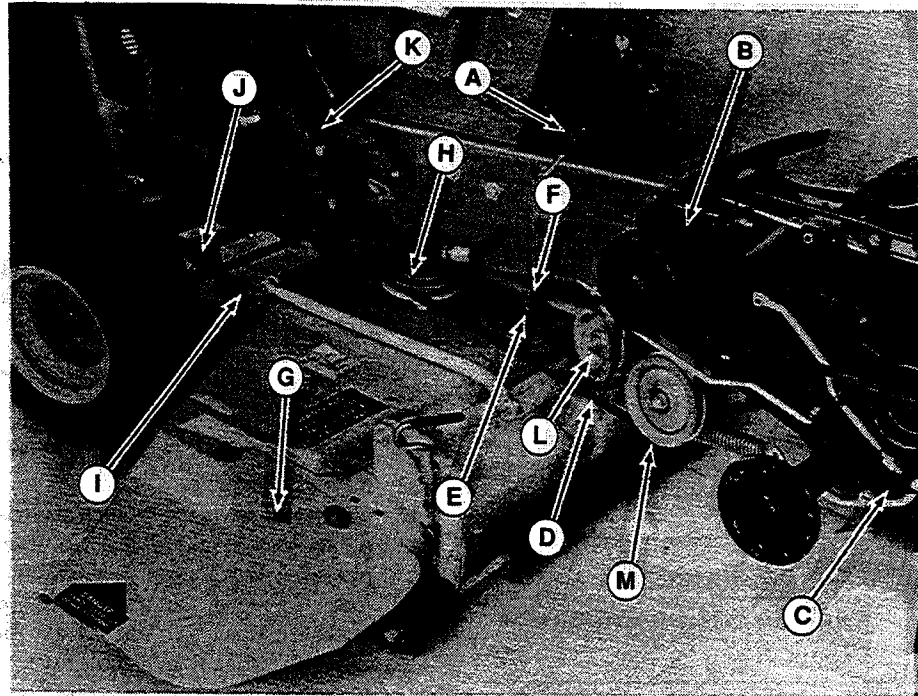

Figure 37. Mower Installation

- A. PTO Clutch Lever
- B. Tractor Drive Pulley
- C. Belt Tensioning Lever
- D. Drive Belt

- E. Lift Anchor
- F. Lift Cable Clevis
- G. Deflector
- H. Mower Driven Pulley

- I. Rocker Arm
- J. Tractor Front Hitch
- K. Lift Lever
- L. Front Idler Pulley
- M. Rear Idler Pulley

Start the engine. With vehicle speed lever in **NEUTRAL**, release the clutch-brake pedal. Push the lift lever forward to lower the cable. Shut off the engine.

Reach under the tractor to grasp the lift cable and pull it straight down. (The lift cable will not lower if no weight is on it.)

4. Slide the mower under the tractor, then turn the front wheels to face straight ahead. Use the lift cable pin and spring clip to attach the tractor lift cable clevis (F) mower lift anchor (E). Use lower hole unless higher lift is desired.
5. Raise the mower using the lift lever or electric lift. (For tractors with hydrostatic lift lever, be sure to shut off engine before leaving the seat.)



WARNING

Keep hands and feet from under mower.

6. Lift the front of the mower and attach the mower hitch to the tractor hitch (J) using two pins and safety clips. Install the pins from the outside. It is easier to install the left-hand pin first.



WARNING

For your personal safety, be sure to remove tractor ignition key after using it to operate the optional electric lift. Accidental starting is possible if the key is left in the ignition.

7. Lower the mower fully using the lift lever or electric lift. (For tractors with hydrostatic lift lever, be sure to shut off engine before leaving seat.)
8. Push the belt tensioning lever (C, figure 37) fully down and forward.
9. Raise the tractor seat to gain access to the PTO pulley.
10. Install the mower drive belt provided on the mower pulley and the tractor pulleys. The belt must be seated in the inner groove of the drive pulley (B). Make sure that flat side of the belt contacts the front idler pulley (L).
11. Pull the belt tensioning lever fully back and up to put tension on the mower drive belt.
12. Pull the belt tensioning lever (C, figure 37) up to tighten the belt. If the belt is

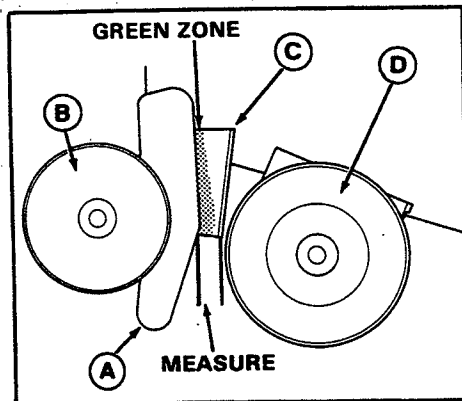

Figure 38. Belt Adjustment

A. Idler Bracket C. Stop
B. Front Idler Pulley D. Rear Idler Pulley

new the rear edge of the idler bracket (A, figure 38) should be aligned with the front edge of the green zone shown in figure 38. The distance between idler bracket (A) and stop (C) will be approximately 1-3/16 inch (30 mm).

If the belt has been used before, the rear edge of the idler bracket (A, figure 38) should be in the middle of the green zone shown in figure 38. The distance between idler bracket (A) and stop (C)

will be approximately 7/8 inch (22 mm).

If adjustment is required, go to step 13.
If adjustment is not required, go to step 14.

13. Push the belt tensioning lever down to release belt tension. Loosen the nut that secures the rear idler pulley (D, figure 38) in the slot. To move the idler bracket (A) forward, move rear idler pulley (D) toward rear. To move the idler bracket (A) toward rear, move the idler pulley (D) forward. Tighten the nut to secure pulley. Pull the belt tensioning lever up and recheck position of idler bracket (A). Readjust if necessary.
14. Operate the tractor with mower engaged for 15 to 30 minutes with a new belt or about two minutes with a used belt. Then stop the engine, remove the key, shift into neutral, set the parking brake and disengage the PTO. Check position of idler bracket (A, figure 38). If the rear edge of idler bracket is in middle of green zone, the belt adjustment is acceptable. If not, readjust the belt as described in step 13.

15. If a new belt or mower was installed, level the mower as described in following procedure.

NOTE

Check belt adjustment periodically during mowing season. Drive belt must be readjusted when rear edge of idler bracket aligns with rear edge of green zone or goes into the red zone.

MOWER LEVELING PROCEDURE

This adjustment is normally required only when installing the mower for the first time or when reinstalling the mower after repairs were made to the tractor or mower hitches which might have affected the level. To level the mower, place tractor and mower on a level surface, set the parking brake, then proceed as follows.



WARNING

For your personal safety, do not handle the sharp mower blades with bare hands. Careless or improper handling of blades may result in serious injury.

1. Check tractor tire pressures. The front tires should have 12 to 15 psi and the rear tires should have 6 to 8 psi.
2. Turn both mower height adjustment handles (A, figure 39) fully clockwise to the highest cutting height position.
3. Rotate the mower blades so the tips point straight forward and backward as shown in figure 39.
4. Measure and note the distance from the front tip of the center blade to the ground.

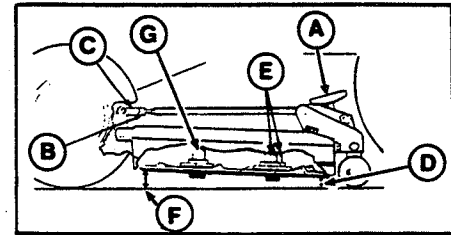

Figure 39. Level Mower

- | | |
|-----------------------------|---------------------------|
| A. Height Adjustment Handle | F. Height of Center Blade |
| B. Jam Nut | G. Front Blade |
| C. Yoke or Eyebolt | |
| D. Height of Side Blades | |
| E. Side Blades | |

5. Measure the distances from the rear tips of the two side blades to the ground. The side blade measurements should be the same, and the rear measurement should be 1/8 to 1/4 inch (3 to 6 mm) less than the measurement for the center blade front tip made in step 4.

NOTE

If the measurements taken are satisfactory, the mower is level and needs no adjustment. If the measurements are incorrect, the mower bail assembly eyebolts (42" mower) or yokes (48" mower) must be adjusted according to step 6. Both eyebolts or yokes must be adjusted to level the mower front to back. If only slight side-to-side leveling of the two side blades is required, the eyebolt or yoke of only one side need be adjusted.



WARNING

To avoid possible injury when performing step 6, block up the front of the mower before removing the eyebolts or yokes so the mower will not drop down.

6. Level the mower according to the following.
 - a. Loosen the jam nuts (B, figure 39).
 - b. Remove the cotter pins and then disconnect the eyebolts or yokes (C, figure 39) from the mower hitch.
 - c. Turning the eyebolts and yokes changes the length of the bail assembly arms. Shorten the bail assembly arms to decrease the front height of the mower. Lengthen the arms to increase the front height. Be sure to give both eyebolts or yokes an equal number of turns for front to back leveling.
 - d. Reinstall the eyebolts or yokes on the hitch (the cotter pins need not be reinstalled yet) to check the blade tip measurements. Continue the adjustment and check until the center blade front tip is 1/8 to 1/4 inch (3 to 6 mm) higher than the side blade rear tips.
 - e. Reinstall the eyebolts or yokes on the hitch and reinstall the cotter

pins. Spread the cotter pins around the hitch pins. Then retighten the jam nuts (B).

MOWER REMOVAL



WARNING

Before leaving operator's position, lower the attachment, shut off engine and remove key, disengage power to attachments, set parking brake and shift transmission into gear.



WARNING

On tractors with hydrostatic lift, it will be necessary to start the engine to raise or lower the mower. Before starting the engine, always seat yourself in operator's position. Before leaving operator's position, shut off the engine and remove the key.

1. Park the tractor on a flat, hard surface where there is room to remove the mower at the left side of the tractor.

2. Push the belt tensioning lever (C, figure 37) fully down and forward to release mower belt tension.
3. Raise the tractor seat deck and remove the mower drive belt from the mower and tractor pulleys (see figure 37). Close the tractor seat deck.
4. Use the tractor lift lever or electric lift to raise the mower.
5. Remove the safety clips and pins to detach the mower hitch from the tractor hitch. Remove the right hand side pin first. Reinstall the pins and safety clips in the mower hitch for storage.
6. Lower the mower fully.
7. Remove the spring clip and pin to detach the lift cable from the mower. Reinstall the pin and spring clip in the lift cable for storage.
8. Turn tractor wheels for a sharp right hand turn, and slide the mower out the left side of the tractor.
9. Pull the belt tensioning lever fully back and up out of the way to prevent damaging it when using the tractor without the mower.

Tractor & Mower Identification

When ordering parts, be prepared to give the identification number of the tractor and mower. The I.D. plate for the mower is located on the mower deck. The I.D. plate for the tractor is located on the left side of the frame.

Refer to the engine manual to locate engine I.D. plate. We suggest you record the number for easy reference.

Tractor Mfg. No.

Tractor Serial No.

Mower Mfg. No.

Mower Serial No.

Engine I.D. No.

Engine Model No.

Specifications

ENGINE - Briggs & Stratton

16 HP Hydrostatic; 16 HP Semi-Automatic

Make: Briggs & Stratton-4 cycle, air cooled, single cylinder

Model No: 326437

Bore & Stroke: 3-9/16 x 3-1/4 in. (91 x 83 mm)

Displacement: 32.4 cu. in. (581 cc)

Air Cleaner: Dual element, paper cartridge and oil foam precleaner

Starter: 12 volt gear drive

Governor: Mechanical, fully enclosed running in oil

Ignition: Flywheel magneto with breaker points

Electrical System: 10 amp flywheel alternator, solid state rectifier - regulator, 45 amp hr. battery

ENGINE - Kohler

12, 14, 16, 17 & 19 HP Hydrostatic;

12 & 17 HP Six Speed; and 14 & 17 HP

Semi Automatic

Make: Kohler - 4 cycle, air cooled

Model No.:

12 HP: K301s (one cylinder)

14 HP: K321 (one cylinder)

16 HP: K341 (one cylinder)

17 HP: KT17 (two cylinder)

19 HP: KT19 (two cylinder)

Bore & Stroke:

12 HP: 3-3/8 x 3-1/4 in.

14 HP: 3.50 x 3.25 in.

16 HP: 3.75 x 3.24 in.

17 HP: 3-1/8 x 2-3/4 in.

19 HP: 3-1/8 x 3-1/6 in.

Displacement: **12 HP:** 29-5/64 cu. in. (475 cc)

14 HP: 31.27 cu. in. (507 cc)

16 HP: 35.89 (588.2 cc)

17 HP: 42-3/16 cu. in. (690 cc)

19 HP: 47 cu. in. (770 cc)

Air Cleaner: Replaceable dry element with precleaner

Starter: Electric gear drive

Governor: **12 HP, 14 HP & 16 HP:** Mechanical flyweight type
17 HP & 19 HP: Oil bathed internal flyweight type

Ignition: Battery ignition with breaker points

Electrical System: 15 amp flywheel alternator, solid state rectifier - regulator, 45 amp hr. battery

CAPACITIES - ALL MODELS

Engine Crankcase Oil: See Engine Manual

Bevel Gear Box: Fill to end of dipstick, with dipstick loosely installed.

Transmission Gear Case - Semi-Automatic & 6 Speed:
56 ounces (1.6 liters)

Final Drive Gear Case - Hydrostatic: 3 quarts (2.8 liters)

Fuel Tank: 3 gallons (11 liters)

STEERING - ALL MODELS

Type of Linkage: Bevel gear - spindle lever type

Steering Gear Ratio: 4.66:1

GROUND DRIVE - HYDROSTATIC

Clutch: Foot operated V-belt clutch between bevel gear & transmission.

Transmission: Air cooled, hydrostatic with variable displacement axial piston pump and with fixed displacement, reversible axial piston motor. Free wheeling valve for maneuvering; of vehicle without starting engine.

Transmission Oil Filter: Spin-on oil filter in charge pump suction line - 25 micron rating.

Final Drive: Hardened spur gears, rolling contact bearings.

Differential: Planetary spur gear, controlled traction.

GROUND DRIVE - SIX SPEED & SEMI-AUTOMATIC

Clutch: Foot operated V-belt clutch between bevel gear box and transmission.

Transmission: Six Speed: Sliding spur gear with 6 speeds forward and two reverse

Transmission: Semi-Automatic: Differential clutch drive to transmission with forward reverse control. Sliding spur gear with 4 gear ratios - hardened spur gears, rolling contact bearings

Differential: Planetary spur gear, controlled traction.

GROUND SPEEDS - HYDROSTATIC

Forward: Variable, up to 7 mph (11 km/h) at 3600 rpm

Reverse: Variable, up to 4 mph (6.4 km/h) at 3600 rpm

GROUND SPEED - SEMI-AUTOMATIC

<u>Gear</u>	<u>Forward or Reverse</u>
1	0.96 mph (1.5 km/h)
2	2.3 mph (3.8 km/h)
3	3.7 mph (5.9 km/h)
4	5.1 mph (8.2 km/h)

GROUND SPEED - SIX SPEED

<u>Gear</u>	<u>Lo - Range</u>	<u>Hi - Range</u>
1	0.7 (1.1 km/h)	1.6 mph (2.5 km/h)
2	1.7 (2.7 km/h)	3.7 mph (5.9 km/h)
3	2.8 (4.5 km/h)	6.1 mph (km/h)
Reverse	1.5 (2.4 km/h)	3.2 mph (5 km/h)

DIMENSIONS - ALL MODELS

Height at Steering wheel: 39.7 in (1008 mm)

Height at Dashboard: 35.7 in. (907 mm)

Width: 36.9 in (953 mm)

Length: 70 in. (1778 mm)

Front Wheel Thread: 30 in. (762 mm)

Rear Wheel Thread: 27 in. (686 mm)

Front Axle Clearance: 8 in. (203 mm)

Wheel Base: 50.7 in (1270 mm)

Front Tires: 16 x 6.50 x 8

Rear Tires: 12 HP, 14 HP: 23 x 8.50 x 12

16 HP, 17 HP & 19 HP: 23 x 10.50 x 12

Turning Radius: Inside Rear Wheels - 32 in.

Outside Front Wheels - 85 in.

MOWER

Effective Cutting Width: 42" - 42 in. (1067 mm)

48" - 48 in. (1219 mm)

Overall Width w/Deflector - 42": 55 in. (1397 mm)

48": 61 in. (1549 mm)

Cutting Height: Adjustable from 1-5/8 to 3-1/8 (41 to 79
(41 to 79 mm))

Number of Blades: 3

Transport Clearance: 3 in. (76 mm), maximum (low cut)

SPECIFICATIONS FOR TRACTORS AND MOWERS ARE SUBJECT TO CHANGE WITHOUT NOTICE.

Parts Manual Availability

Parts Manuals are fully illustrated. All of the assemblies are shown in exploded views which show the relationship of the parts and how they go together. Important assembly notes and special torque values are included in the illustrations. For standard hardware, a torque specification chart is included.

For the manual applicable for your model, contact the Simplicity Customer Publications Department at (414) 284-8519. Have the following information available when phoning in your request.

Model: _____

Mfg. No.: _____

Your Name: _____

Address: _____

City, State, Zip: _____

Visa/Mastercard No.: _____

Expiration Date: _____

Allow 3-4 weeks for delivery.



***Extend Equipment Life -
Use Only Genuine Factory
Authorized Repair Parts***



Common Replacement Parts

Listed below are part numbers for the more common replacement parts. Use the order form at the back of the manual to order a complete illustrated parts manual. Only genuine Simplicity replacement parts will assure optimum performance and safety. DO not attempt repairs or maintenance unless proper procedures and safety precautions are followed. For assistance in any area, see your dealer.

QTY	DESCRIPTION	NUMBER
1	Cotter Pin - lift cable	1918448
1	Spring Clip - lift cable	1918196
1	Transmission Belt - Hydro	1650502
1	Transmission Belt - 6 Speed	1607967
1	Shuttle Main Drive Belt (longer)	174731
1	Shuttle Drive Belt - secondary	174883
1	2 Keys with ring	122203
2	Sealed Beam Lamps	1665853
3	Blade - 42" mower (Mfg. No. 1690501)*	1656144
3	Blade - 48" mower (Mfg. No. 1690502)*	1656143
3	Blade - 42" mower (Mfg. No. 1691218)*	1679917
3	Blade - 48" mower (Mfg. No. 1691219)*	1679916
1	Belt - 42" mower	1656960
1	Belt - 48" mower	1657044
2	Mower Hitch Pins	118053
2	Clips for mower hitch pins	176012
2	Cotter pin for levelling mechanism	1918452

QTY	DESCRIPTION	NUMBER
2	Pins - Levelling - 48" only	1960116
2	Pivot Pin - Levelling - 42" only	1651516
1	Battery	1685058
	Simplicity SAE 5W-30 Cold Weather Engine Oil (Case of 12 Quarts)	***1685576
	Simplicity SAE 15W-40 SS/CD Engine Oil (Case of 12 Quarts)	***1685554
	Grease Gun Kit (incl. grease)	1685510
	Extra 8 OZ. Tube - for above	103077
**	Touch-Up Paint (ORANGE, Spray Can)	1685558
**	Touch-Up Paint (WHITE, Spray Can)	103049
	Multi-Purpose Hydraulic/Transmission Oil (Case of 12 Quarts)	***1685516

Pneumatic Tire Seal - Stops Leaks	
Available in the following amounts:	
11 Oz. Tube	1685523
Case of 24-11Oz. Tubes	1685525

*Refer to I.D. Plate on mower to locate Mfg. No. of mower to order the correct blades.

**Also available in 1/2 Oz. Brush Cap Daubers.

***See your dealer to buy one-quart cans.

SIMPLICITY MANUFACTURING, INC.
500 N. Spring Street., P.O. Box 997
Port Washington, WI 53074-0997 USA

FORM 1701323-01
Rev. 4/96
© Copyright 1996 Simplicity Manufacturing, Inc.
All Rights Reserved. Printed In USA.