

**Parts
Manual
Models
7110 & 7116
Six Speed**

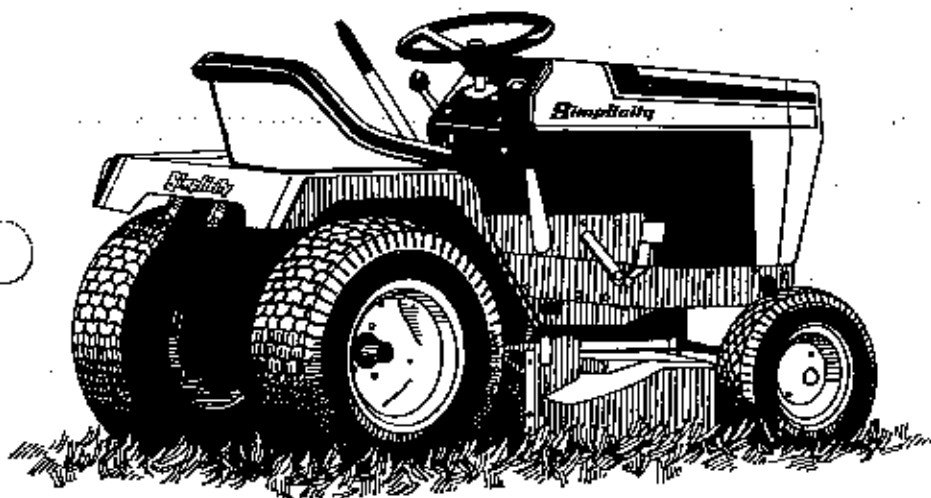

10 H.P. TRACTOR
MFG. NO. 1690472
16 H.P. TRACTOR
W/TURF TIRES
MFG. NO. 1690475
16 H.P. TRACTOR
W/AGRICULTURAL TIRES
MFG. NO. 1690476

753
TP-526
PRINTED IN U.S.A.
797

Simplicity

AN ALLIS CHALMERS COMPANY

Attention Dealers:

For quick, accurate reference when making warranty claims, group numbers are given with each parts section.

Standard torques appear in a chart at the end of the manual, while important individual torques are given on specific parts drawings.

CRITICAL and MAJOR notations point out important facts or instructions which relate to personal safety and proper machine operation. Any CRITICAL notation **C** which may appear in this book, pinpoints characteristics which, if not properly followed, can create a safety hazard. Any MAJOR notation **M** which may appear in this book, marks characteristics which, if not properly followed, may result in operating failure, shortened product life, or greatly reduced quality of the unit.

When ordering parts, keep your tractor's serial number and manufacturer's number in mind. Variations may occur in a part between early and later model tractors, causing the tractor serial number to be listed in the parts description whenever these variations occur.

For your convenience, assembly notes are included in parts drawings to assist in repair and assembly of unit.

Simplicity
Technical Publications

NOTE: SPECIFICATIONS MAY CHANGE WITHOUT NOTICE.

© Simplicity Manufacturing Co., Division of Allis-Chalmers, 1979

Table of Contents

FRAME & FOOTREST GROUP	2
FRONT AXLE GROUP	4
STEERING GROUP	6
ENGINE, EXHAUST & DRIVE SHAFT GROUP (7110 ONLY)	8
ENGINE, EXHAUST & DRIVE SHAFT GROUP (7116 ONLY)	10
DRIVE & CLUTCH GROUP	12
BRAKE GROUP	14
BRAKE LINKAGE GROUP	16
TRANSMISSION GROUP	18
TRANSMISSION BRAKE, DRIVE & CONTROL GROUP	22
P.T.O. CONTROL GROUP	24
P.T.O. CONE CLUTCH GROUP	26
LIFT LEVER & CABLE GROUP	28
BEVEL GEAR & SIDE PLATE GROUP	30
DRAW BAR GROUP	32
REAR AXLE & DIFFERENTIAL GROUP	34
ELECTRICAL GROUP (7110 ONLY)	36
ELECTRICAL GROUP (7116 ONLY)	38
DASH GROUP	40
HOOD & GRILLE GROUP	42
SEAT & DECK GROUP	44
DECAL GROUP	46
TIRE & WHEEL GROUP	48
STANDARD HARDWARE TORQUE SPECIFICATIONS	Inside Back Cover

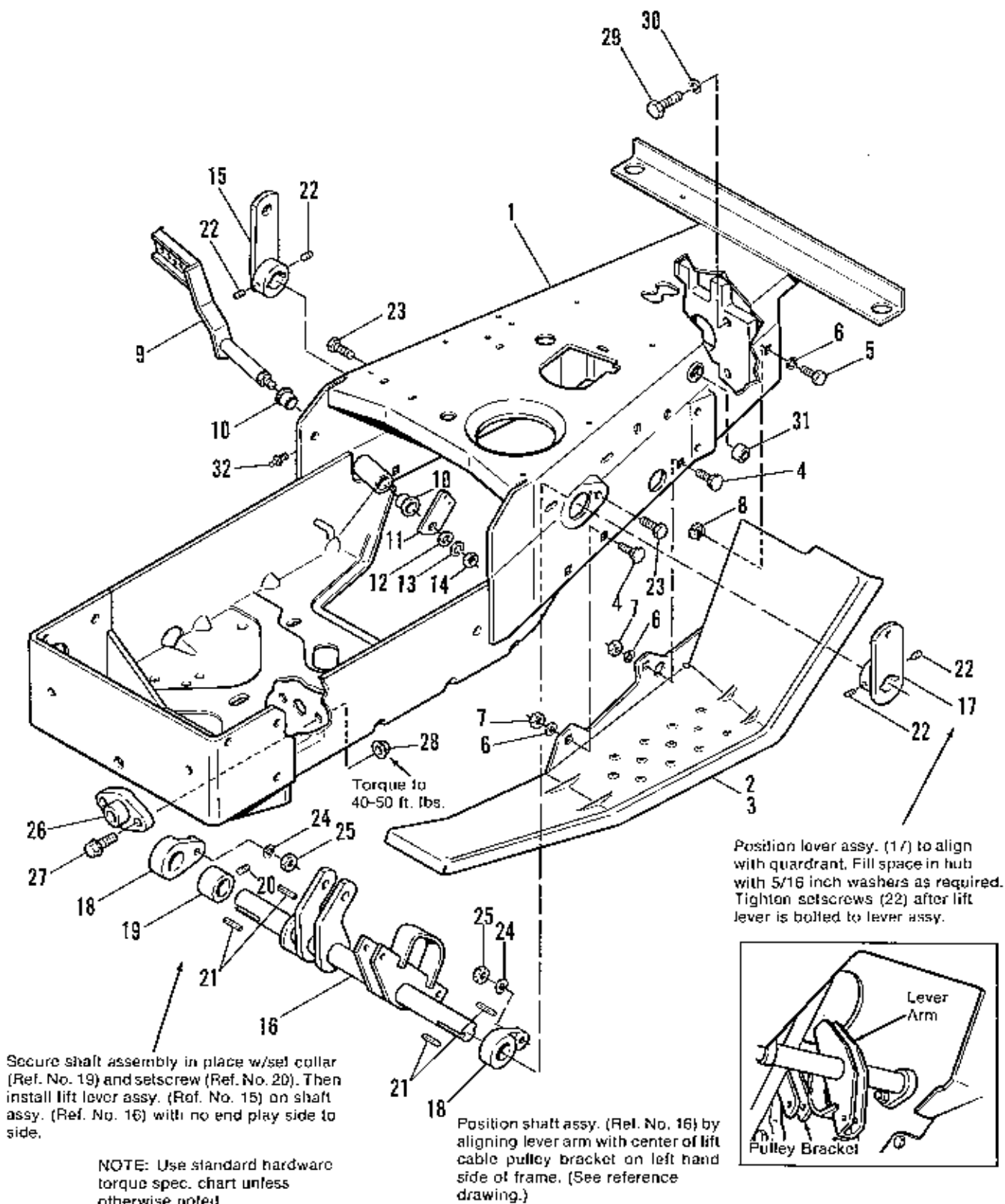

Ref. No.	Part No.	Qty.	Description
*1	1667097	1-2	FRAME & BUSHING ASSY.
2	1665909	1	FOOTREST, R.H.
3	1665908	1	FOOTREST, L.H.
4	920562	4	BOLT, Carriage, 5/16-18 x 3/4
5	921332	2	CAPSCREW, Hex Hd., 5/16-18 x 3/4
6	917356	6	LOCKWASHER, 5/16
7	917372	4	NUT, Hex, Full, 5/16-18
8	920470	2	NUT, Speed, Tinnerman, 5/16-18
9	1657472	1	FOOT PEDAL ASSY.
10	108419	2	BUSHING
11	157300	1	ARM, Foot Pedal
12	917378	1	WASHER, 3/8
13	916965	1	LOCKWASHER, 3/8
14	916950	1	NUT, Hex, Full, 3/8-16
15	157625	1	FRONT LIFT LEVER ASSY. (R.H.)
16	1663168	1	LIFT SHAFT ASSY.
17	171593	1	LIFT LEVER ASSY. (L.H.)
18	170975	2	BEARING, Lift Lever
19	157624	1	COLLAR, Set
20	928709	1	SETSCREW, Cup Pt., 5/16-18 x 3/8
21	157652	4	KEY
22	928734	4	SETSCREW, Skt. Hd., 5/16-18 x 1/4
23	921977	2	CAPSCREW, Hex Hd., 5/16-18 x 1-1/4
24	917356	2	LOCKWASHER, 5/16
25	917372	2	NUT, Hex, Full, 5/16-18
26	1653876	1	BEARING, Pivot
27	928727	2	CAPSCREW, Hex, Whiztock, 3/8-16 x 1-1/4
28	928352	2	LOCKNUT, Hex, Flange, Whiz, 3/8-16.
29	921212	4	CAPSCREW, Hex Hd., 7/16-14 x 1-1/2
30	918199	4	LOCKWASHER, 7/16
31	174662	1	BUSHING
32	921133	1	FITTING, Lube

*Ref. No. 1 includes Ref. No's. 31 & 32.

Adjust length of drag link assy. (Ref. No. 10) by positioning end ball joint so that front wheels will be in the straight ahead position when the timing marks on the steering pinion and gear are aligned. The steering wheel mounting hole \odot is to be parallel to fore and aft \odot of tractor.

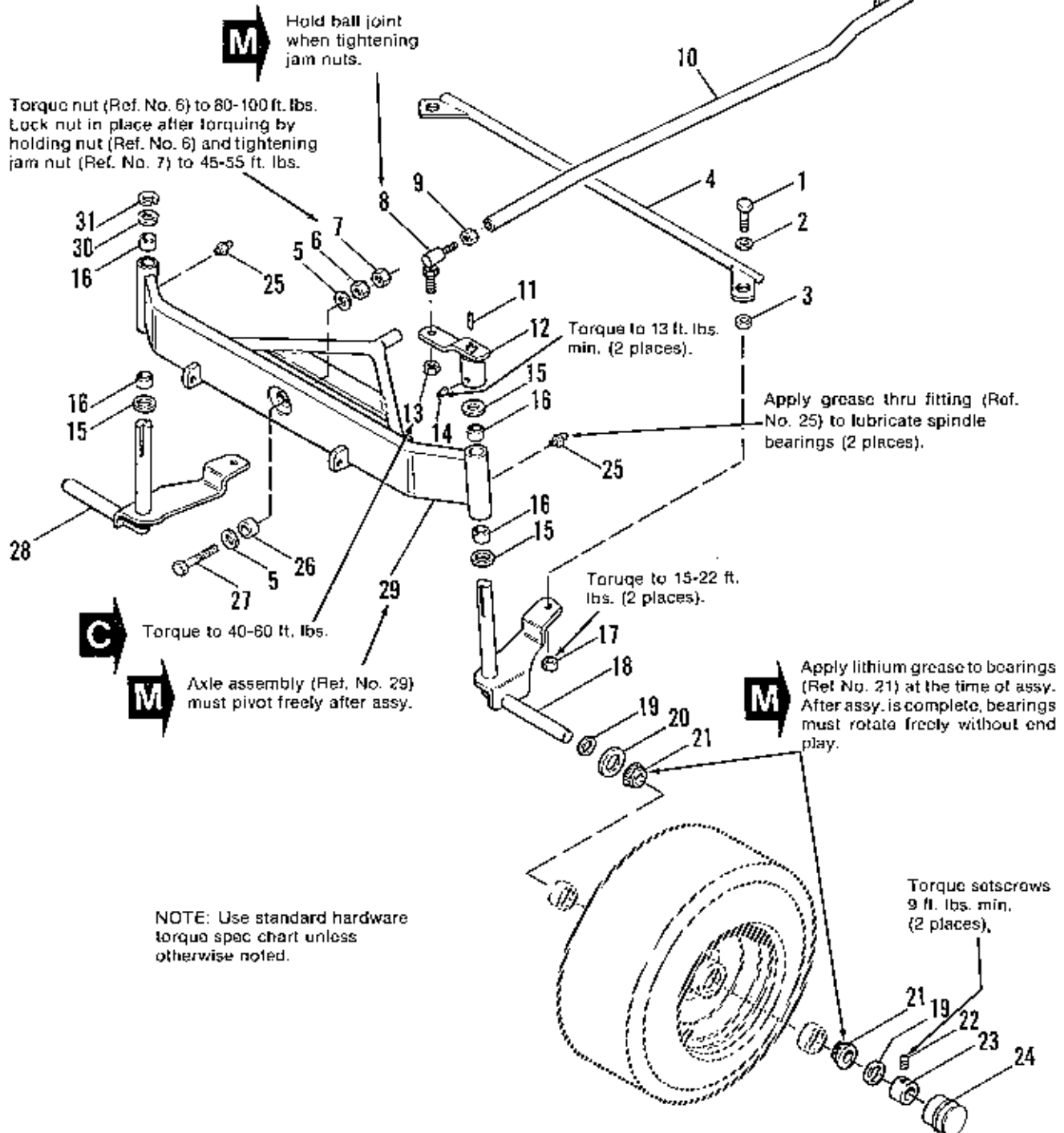

Ref. No.	Part No.	Qty.	Description
1	921210	2	CAPSCREW, Hex Hd., 3/8-16 x 1
2	917378	2	WASHER, Plain, 3/8
3	154177	2	SPACER
4	157499	1	TIE ROD ASSY.
5	918431	2	WASHER, Plain, 1/2
6	930648	1	LOCKNUT, Hex, 1/2-13
7	913744	1	NUT, Hex, Jam, 1/2-13
8	164272	1	JOINT, Ball
9	919262	1	NUT, Hex, Jam, 1/2-20
10	1666648	1	DRAG LINK ASSY.
11	157427	2	KEY, Square
12	170998	1	ARM ASSY., Steering
13	930245	1	LOCKNUT, Hex, 1/2-20
14	928721	2	SETSCREW, Sq. Hd., 5/16-18 x 1/2
15	108181	3	WASHER
16	154289	4	BUSHING
17	923428	2	LOCKNUT, Hex, 3/8-16
18	171774	1	SPINDLE ASSY., L.H.
19	171375	4	SPACER
20	170168	2	SEAL
21	154486	4	BEARING, Cone
22	928691	2	SETSCREW, Skt. Hd., 5/16-18 x 5/16
23	8021010	2	COLLAR, Sot
24	154487	2	CAP, Hub
25	914687	2	FITTING, Grease
26	157618	1	SPACER
27	927496	1	CAPSCREW, Hex Hd., 1/2-13 x 2-1/4
28	157494	1	SPINDLE ASSY., R.H.
29	1650553	1	FRONT AXLE ASSY.
30	8061012	1	WASHER
31	157286	1	RING, Retaining

NOTE: See pages 48 & 49 for Wheel & Tire Assy. parts list.

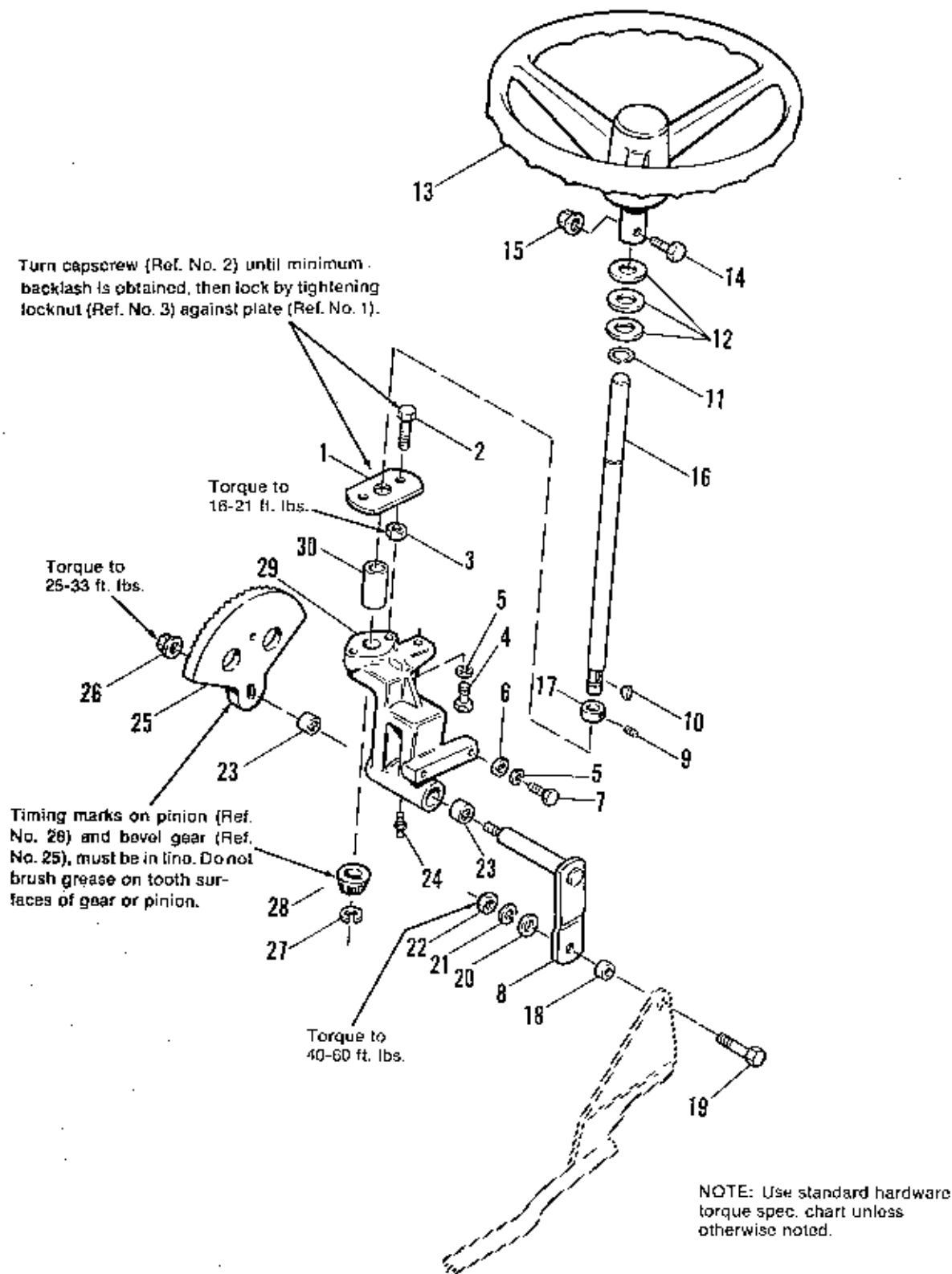

Ref. No.	Part No.	Qty.	Description
1	171000	1	PLATE, Steering
2	920415	2	CAPSCREW, Hex Hd., 3/8-16 x 1-1/4
3	928731	2	LOCKNUT, Hex, Jam, 3/8-16
4	921965	1	CAPSCREW, Hex, 3/8-16 x 3/4
5	916965	3	LOCKWASHER, 3/8
6	917378	2	WASHER, Plain, 3/8
7	921966	2	CAPSCREW, Hex Hd., 3/8-16 x 7/8
8	1666204	1	ARM ASSY., Steering
9	928734	1	SETSCREW, Skt. Hd., 5/16-18 x 1/4
10	910224	1	KEY, Woodruff #8, 5/32 x 5/8
11	154264	1	RING, Retaining
12	158223	3	WASHER, Nylon, 3/4
13	1606342	1	WHEEL, Steering
14	921977	1	CAPSCREW, Hex Hd., 5/16-18 x 1-1/4
15	929001	1	LOCKNUT, Flange, 5/16-18
16	171020	1	SHAFT, Steering
17	8021010	1	COLLAR, Set
18	105051	1	SPACER
19	920328	1	CAPSCREW, Hex Hd., 1/2-13 x 1-1/2
20	918431	1	WASHER, Plain
21	916966	1	LOCKWASHER, 1/2
22	916951	1	NUT, Hex, 1/2-13
23	154258	2	BEARING, Needle
24	914687	1	FITTING, Grease
25	170987	1	GEAR, Bevel
26	930650	1	LOCKNUT, Hex, Flange, 7/16-14
27	1602155	1	"E" RING
28	170988	1	PINION, Bevel
*29	171832	1	HOUSING ASSY., Steering
30	170992	1	BUSHING

*Reference No. 29 includes Ref. No's. 23 & 30.

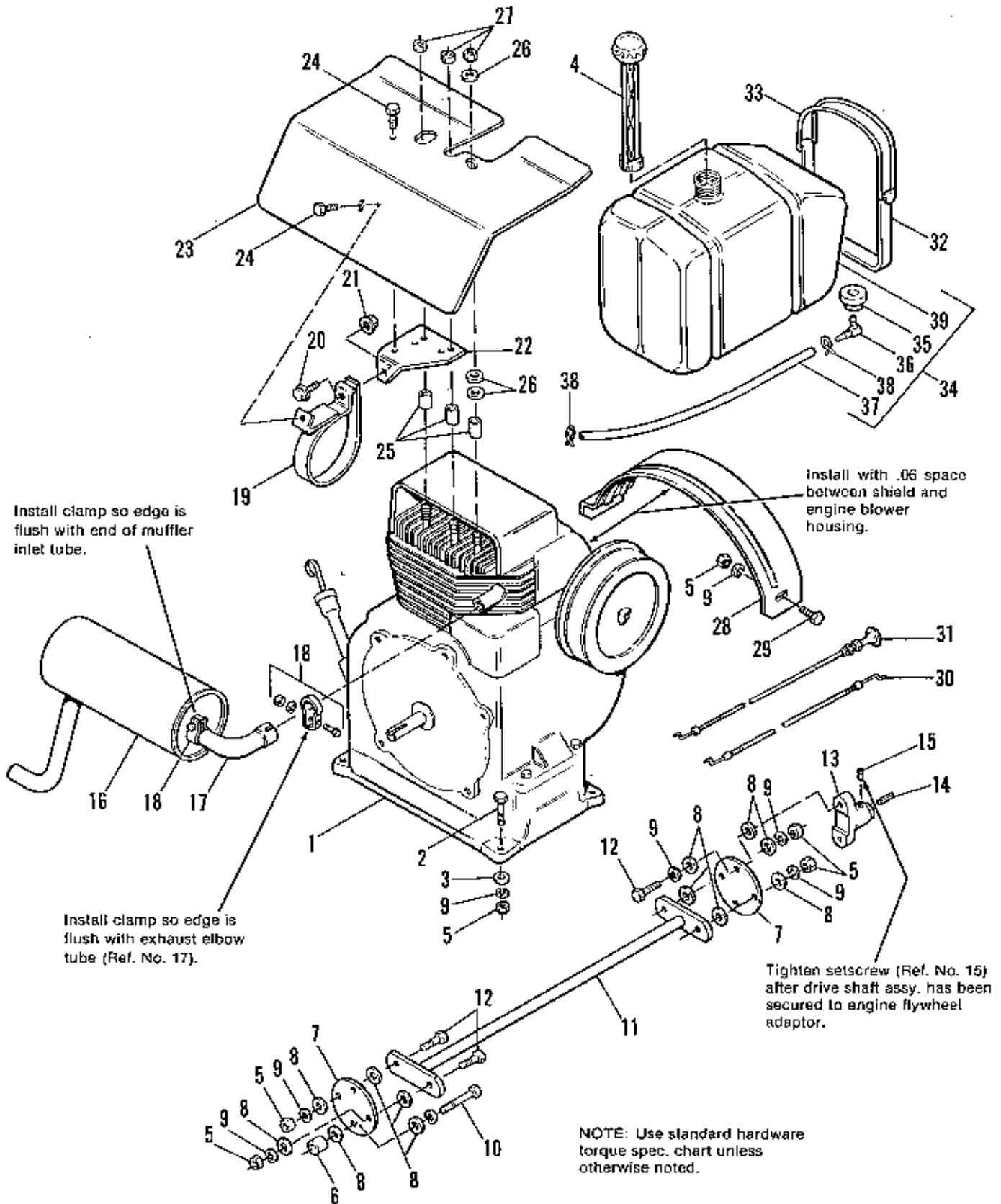

Ref. No.	Part No.	Qty.	Description
1		1	ENGINE, 10 H.P. Kohler
2	921969	4	CAPSCREW, Hex Hd., 3/8-16 x 1-1/2
3	917378	4	WASHER, 3/8
4	171252	1	CAP, Fuel Tank, Gauge
5	916950	10	NUT, Hex, 3/8-16
6	1656397	2	SPACER
7	173026	2	COUPLING
8	157424	16	WASHER, Special
9	916965	14	LOCKWASHER, 3/8
10	922130	2	CAPSCREW, Hex Hd., 3/8-16 x 2-1/4
11	1666152	1	SHAFT ASSY., Drive
12	920415	6	CAPSCREW, Hex Hd., 3/8-16 x 1-1/4
13	172264	1	FLANGE, Drive Shaft
14	157427	1	KEY, Drive Shaft
15	924624	1	SETSCREW, 3/8-24 x 3/8
16	1666059	1	MUFFLER, Exhaust
17	1666120	1	ELBOW, Exhaust
18	172061	2	CLAMP, Muffler
19	1666833	1	STRAP ASSY., Muffler
20	933689	1	CAPSCREW, Hex, Flange, Whizlock, 5/16-18 x 1-1/2
21	925763	1	LOCKNUT, Hex, Flange, Whiz, 5/16-18
22	1666837	1	SUPPORT, Muffler
23	1666838	1	SHIELD, Hoat
24	925003	2	SCREW, Hex Hd., Taptite, 1/4-20 x 1/2
25	121121	3	SPACER
26	156065	3	WASHER
27	928731	3	LOCKNUT, Jam, 3/8-16
28	1666805	1	SHIELD
29	921965	2	CAPSCREW, Hex Hd., 3/8-16 x 3/4
30	1666266	1	CONTROL, Throttle
31	1666269	1	CONTROL, Choke
32	171330	2	STRAP, Tank
33	172744	2	STRAP, Fuel Tank
34	1666271	1	FUEL TANK ASSY.
35	1654930	1	BUSHING
36	1664460	1	FITTING
37	1666276	1	HOSE, Fuel
38	154372	2	CLAMP, Hose
39		1	TANK, Fuel (See Ref. No. 34)

*Reference No. 34 includes Ref. No's. 35, 36, 37, 38 (Qty. 1), 39.

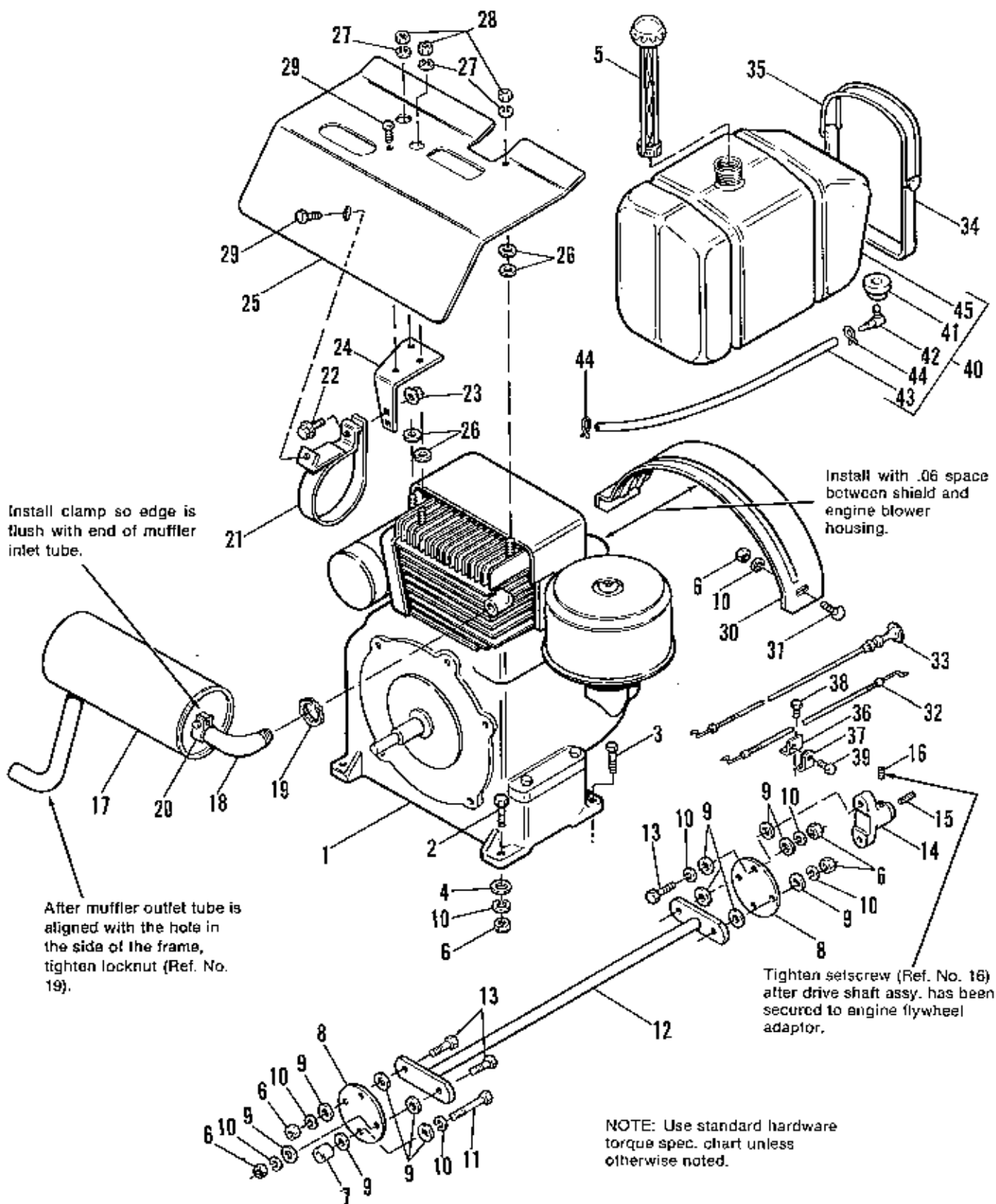

Ref. No.	Part No.	Qty.	Description
1		1	ENGINE, 16 H.P. Briggs & Stratton
2	921969	2	CAPSCREW, Hex Hd., 3/8-16 x 1-1/2
3	172455	2	CAPSCREW, Hex Hd., 3/8-16 x 1-5/16
4	917378	4	WASHER, 3/8
5	171252	1	CAP, Fuel Tank, Gauge
6	916950	10	NUT, Hex, 3/8-16
7	1666397	2	SPACER
8	173026	2	COUPLING
9	157424	16	WASHER, Special
10	916965	14	LOCKWASHER, 3/8
11	922130	2	CAPSCREW, Hex Hd., 3/8-16 x 2-1/4
12	1666152	1	SHAFT ASSY., Drive
13	920415	6	CAPSCREW, Hex Hd., 3/8-16 x 1-1/4
14	172264	1	FLANGE, Drive Shaft
15	157427	1	KEY, Drive Shaft
16	924624	1	SETSCREW, 3/8-24 x 3/8
17	1666059	1	MUFFLER, Exhaust
18	1666122	1	ELBOW ASSY., Exhaust
19	154378	1	LOCKNUT
20	172061	1	CLAMP, Muffler
21	1666833	1	STRAP ASSY., Muffler
22	933669	1	CAPSCREW, Hex, Flange, Whizlock, 5/16-18 x 1/2
23	925763	1	LOCKNUT, Hex, Flange, Whiz, 5/16-18
24	1666895	1	SUPPORT, Muffler
25	1666831	1	SHIELD, Heat
26	917642	4	WASHER, 5/16
27	917356	3	LOCKWASHER, 5/16
28	917372	3	NUT, Hex, 5/16-18
29	925003	2	SCREW, Hex Hd., Taptite, 1/4-20 x 1/2
30	1666805	1	SHIELD
31	921965	2	CAPSCREW, Hex Hd., 3/8-16 x 3/4
32	1666268	1	CONTROL, Throttle
33	1666269	1	CONTROL, Choke
34	171330	2	STRAP, Tank
35	172744	2	STRAP, Fuel Tank
36	1656453	1	BRACKET, Cable
37	158475	1	CLIP, Bowden Wire
38	927429	1	SCREW, Hex Hd., 1/4-20 x 5/8
39	929477	1	SCREW, Taptite #10-24 x 1/2
*40	1666275	1	TANK ASSY., Fuel
41	1654930	1	BUSHING
42	1664460	1	FITTING
43	1666278	1	HOSE, Fuel
44	154372	2	CLAMP, Hose
45		1	TANK, Fuel (See Ref. No. 40)

*Reference No. 40 includes Ref. No's. 41, 42, 43, 44 (Qty. 1), 45.

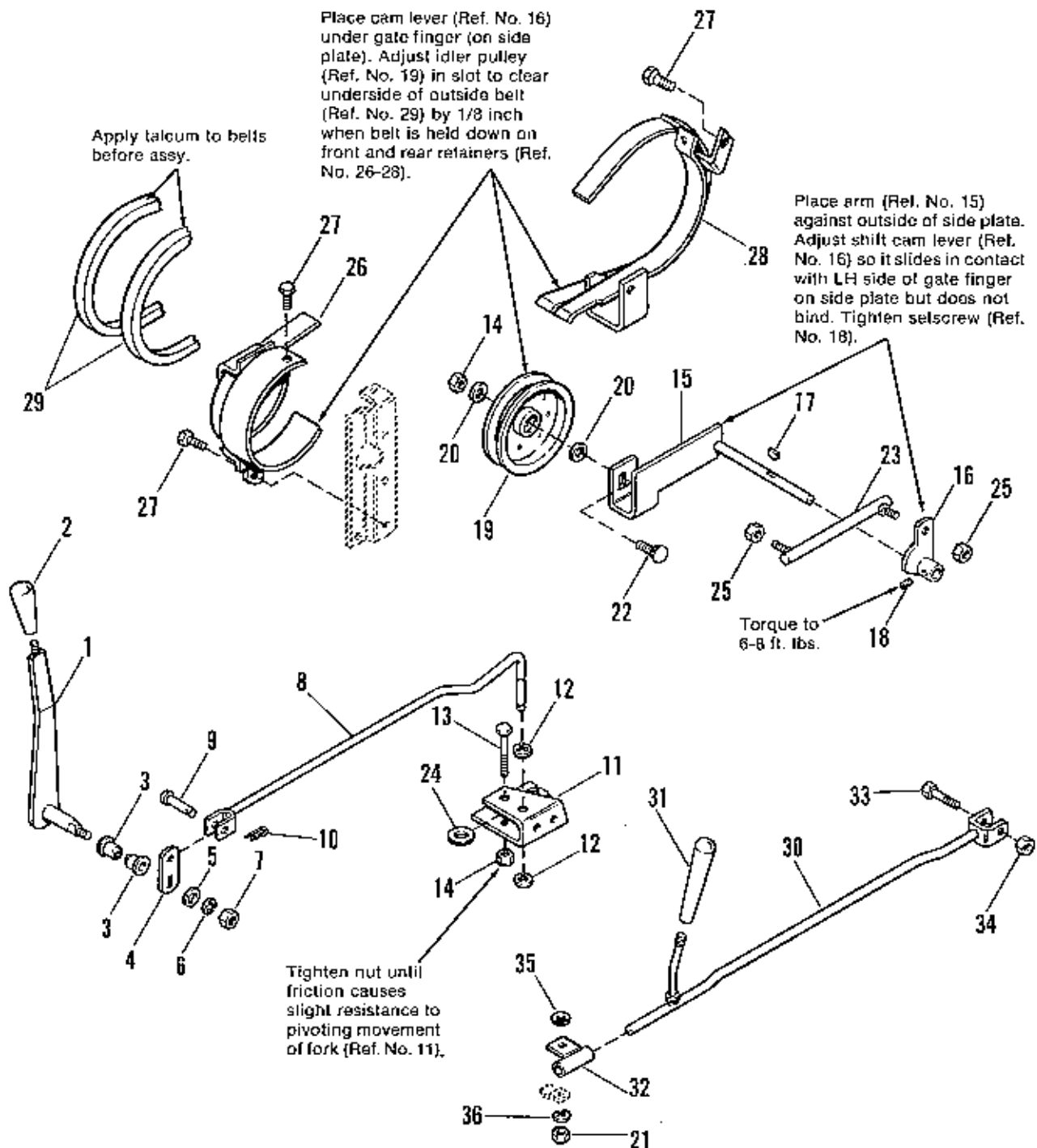

Ref. No.	Part No.	Qty.	Description
1	1656454	1	CONTROL LEVER ASSY.
2	172038	1	KNOB
3	108419	2	BUSHING, Flanged
4	164123	1	LINK
5	917378	1	WASHER, 3/8
6	916965	1	LOCKWASHER, 3/8
7	916950	1	NUT, Hex, Full, 3/8-16
8	1656457	1	CONTROL ROD ASSY.
9	1651167	1	PIN
10	918447	1	PIN, Cotter, 3/32 x 3/4
11	1606567	1	FORK, Shift
12	1602735	2	"E" RING, External
13	923701	1	CAPSCREW, Hex Hd., 3/8-16 x 2
14	930651	2	LOCKNUT, Hex, 3/8-16
15	1607025	1	IDLER ARM ASSY.
16	1607026	1	CAM SHIFT LEVER ASSY.
17	905121	1	KEY, Woodruff, #5, 1/8 x 5/8
18	928804	1	SETSCREW, Sq. Hd., 1/4-20 x 1/4
19	1606554	1	PULLEY, Idler
20	917642	2	WASHER, 5/16
21	916622	1	NUT, Hex, Full, 1/4-20
22	922109	1	BOLT, Carriage, 3/8-16 x 1-1/4
23	1606568	1	JOINT, Ball, Dbl. End
24	1657516	1	WASHER
25	926591	2	LOCKNUT, Hex, Full, 5/16-24
26	1657077	1	BELT RETAINER ASSY.
27	924856	3	SCREW, Taptite, 5/16-18 x 1/2
28	1657546	1	REAR RETAINER ASSY.
29	1607967	2	BELT, "V", Drive
30	171559	1	SHIFT ROD ASSY.
31	164180	1	HANDLE, Shift Rod
32	157020	1	SHIFT ROD GUIDE ASSY.
33	930570	1	CAPSCREW, Hex Hd., 5/16-18 x 1-1/2
34	923362	1	NUT, Hex, Full, 5/16-18
35	106785	1	WASHER, Cup
36	916964	1	LOCKWASHER, 1/4



Adjust transmission brake as follows:

- Place .030 shim between cam lever (Drive & Clutch Group) and gate finger (on side plate).
- Adjust and set parking brake (Brake Linkage Group).
- Run brake rod adjusting nut (15) in until it contacts brake band (finger tight) plus 1/3 turn (2 flats on nut) then tighten locking nut (16) against adjustment nut (15) to secure brake adjustment.

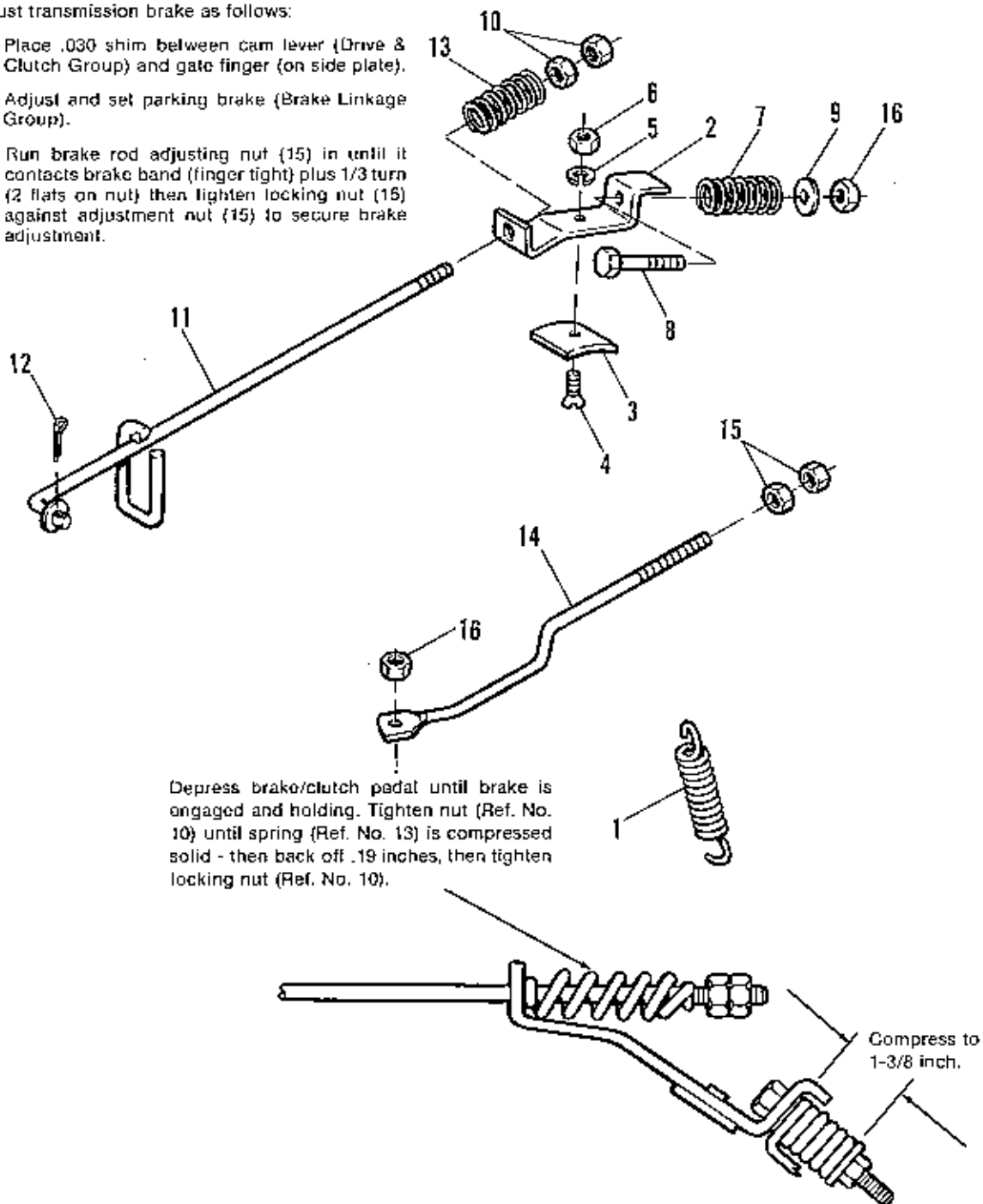

NOTE: Use standard hardware torque spec. chart unless otherwise noted.

Ref. No.	Part No.	Qty.	Description
1	174896	1	SPRING
2	1657545	1	STRAP, Pulley Brake
3	1610590	1	BRAKE, Sheave
4	926267	1	SCREW, Machine, No. 10-24 x 5/8
5	917365	1	LOCKWASHER, #10
6	916621	1	NUT, Hex, Full, #10-24
7	1610703	1	SPRING
8	919355	1	CAPSCREW, Hex, 5/16-18 x 2-1/4
9	917377	1	WASHER, 1/4
10	917372	2	NUT, Hex, Full, 5/16-18
11	1608621	1	PULLEY BRAKE ROD ASSY.
12	919313	1	PIN, Cotter, 3/32 x 1/2
13	157041	1	SPRING
14	172722	1	ROD, Brake
15	916950	2	NUT, Hex, Full, 3/8-16
16	923362	2	LOCKNUT, Hex, 5/16-18

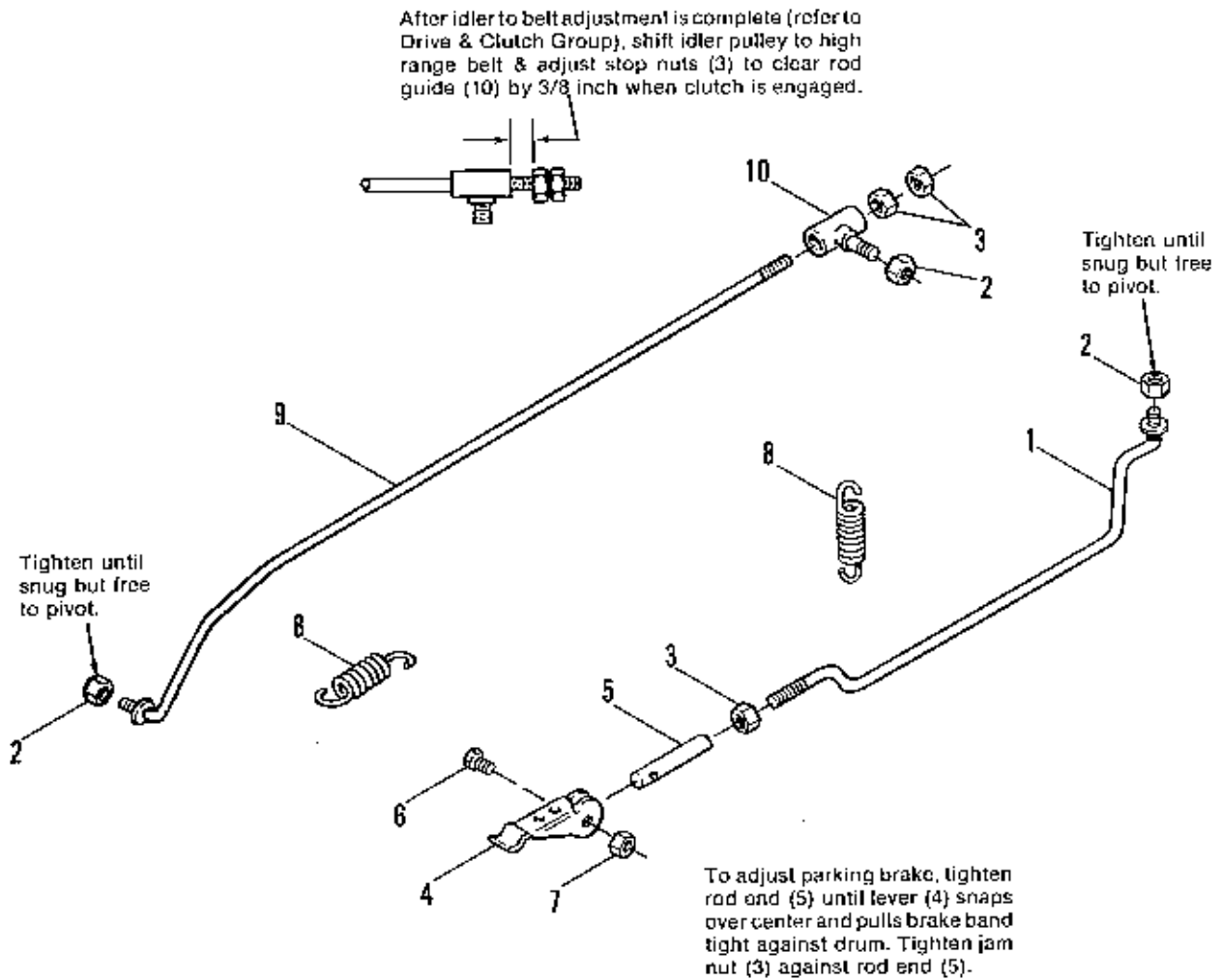

NOTE: Use standard hardware torque spec. chart unless otherwise noted.

Ref. No.	Part No.	Qty.	Description
1	1666791	1	PARKING BRAKE ROD ASSY.
2	923362	3	LOCKNUT, Hex, 5/16-18
3	917372	3	NUT, Hex, Full, 5/16-18
4	172108	1	LEVER, Parking Brake
5	171994	1	END, Rod
6	928771	1	CAPSCREW, Hex Hd., 1/4-20 x 1
7	923358	1	LOCKNUT, Hex, 1/4-20
8	121037	2	SPRING
9	1656455	1	CLUTCH & BRAKE ROD ASSY.
10	164094	1	ROD GUIDE ASSY.

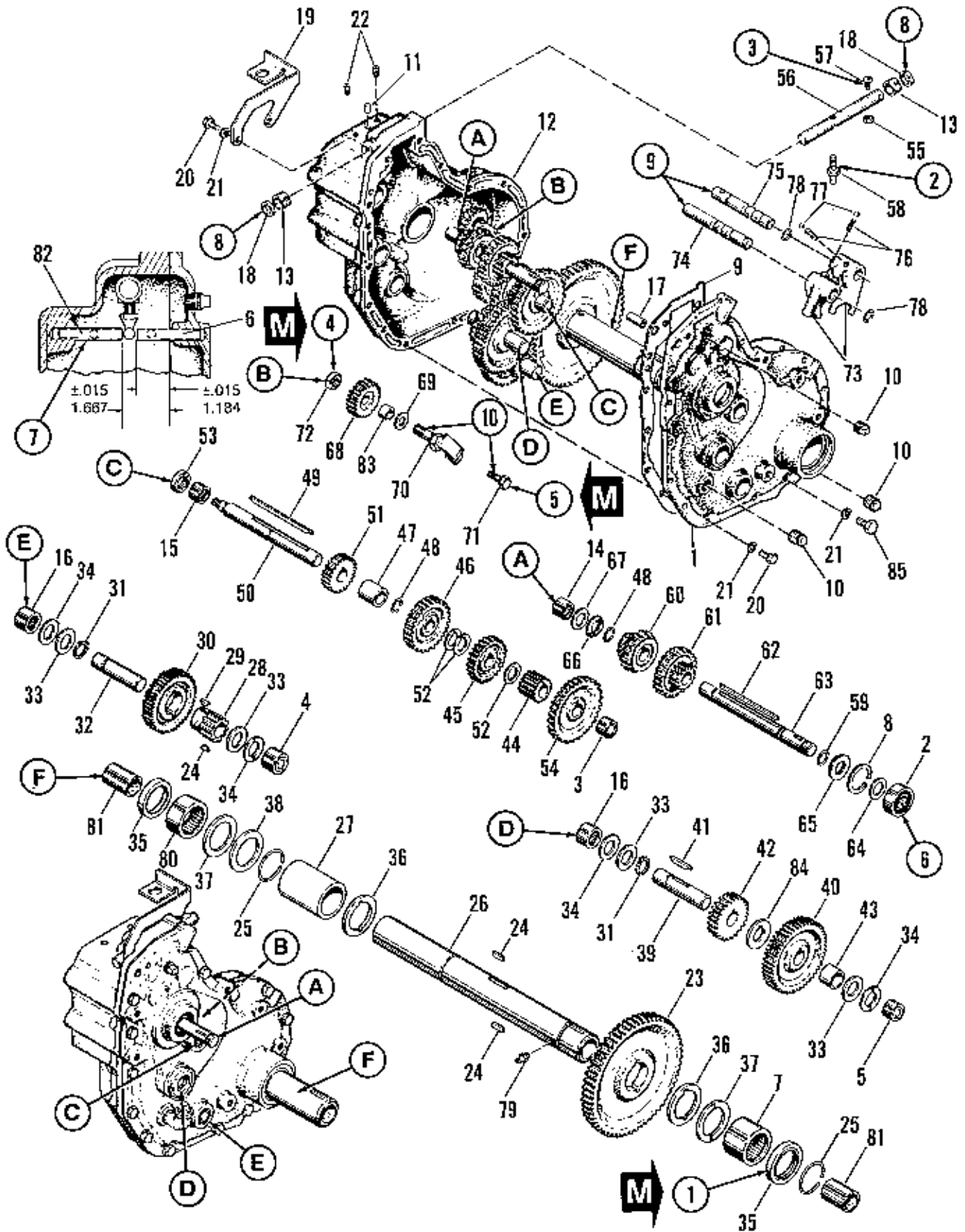

Ref. No.	Part No.	Qty.	Description
1	164226	1	COVER, Gear Case
2	108202	1	BEARING, Ball
3	154257	1	BEARING, Needle
4	154259	1	BEARING, Needle
5	154271	1	BEARING, Needle
6	154537	1	ROLL PIN ASSY.
7	157520	1	BEARING, Needle
8	164064	1	RING, Retaining
9	164234	1	GASKET, Gear Case
10	901653	3	PLUG, Pipe, Sq. Hd., 3/8
11	118462	1	PLUG, Vent
12	157516	1	GEAR CASE ASSY.
13	121084	2	SPACER, Diff.
14	154257	1	BEARING, Needle
15	154258	1	BEARING, Needle
16	154259	2	BEARING, Needle
17	918113	2	PIN, Spring, 3/8 x 1
18	157619	2	SEAL, Oil
19	164251	1	SUPPORT, Switch
20	921333	15	CAPSCREW, Hex Hd., 5/16-18 x 1
21	917356	16	LOCKWASHER, 5/16
22	917231	2	SETSCREW, Skt. Hd., 5/16-18 x 1/2
23	154095	1	GEAR, Drive
24	154096	2	KEY
25	154268	2	RING, Snap
26	164222	1	TUBE & BUSHING ASSY.
27	154098	1	SPACER, Axle Tube
28	154092	1	PINION, 3rd Interm.
29	910224	2	KEY, Woodruff, #6
30	164051	1	GEAR, 3rd Interm.
31	154266	2	RING, Retaining
32	154091	1	SHAFT, 3rd Interm.
33	172978	4	WASHER
34	172979	4	WASHER
35	154269	2	SEAL
36	154130	2	WASHER, Axle Tube
37	172977	2	WASHER, Axle Tube
38	154097	1	WASHER, Axle Tube
39	154086	1	SHAFT, 2nd Interm.
40	154089	1	GEAR, 2nd Interm.
41	154267	1	KEY
42	164062	1	PINION, 2nd Interm.
43	154090	1	SPACER
44	154079	1	PINION, 1st Interm.
45	154080	1	PINION, Driver III
46	154081	1	GEAR, Driver II
47	154082	1	SPACER
48	154264	1	RING, Retaining
49	154354	2	KEY
50	157290	1	SHAFT, 1st Interm.

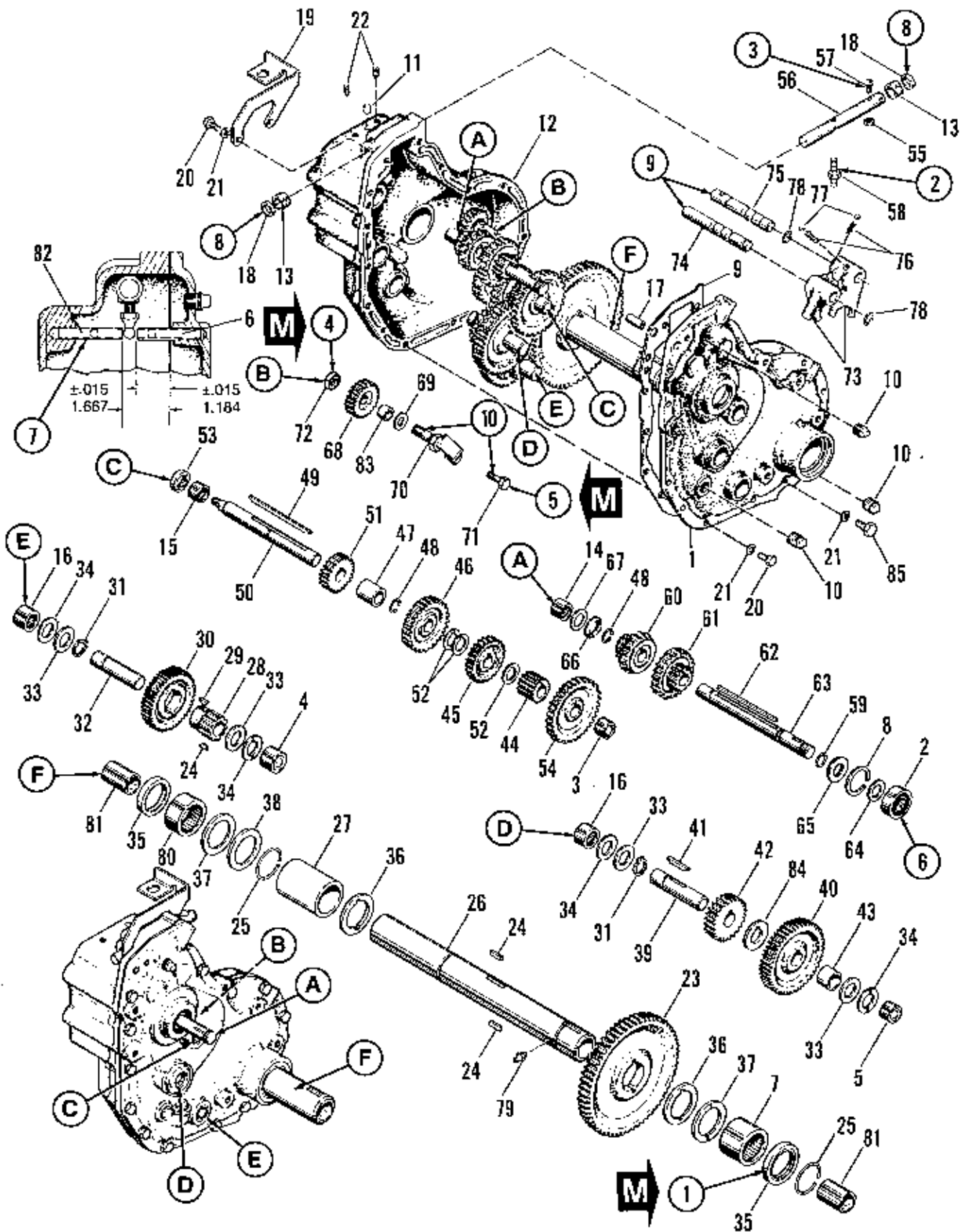

NOTE: PARTS REF. NO. 51-85 CONTINUED
ON THE FOLLOWING PAGE.



Ref. No.	Part No.	Qty.	Description
51	174228	1	PINION, Rev. & IV
52	8061012	3	WASHER
53	154263	1	SEAL, Oil
54	154078	1	GEAR, Driven I
55	920161	1	NUT, Hex, Jam, 5/16-18
56	1665525	1	ROD, Shift
57	172241	1	BOLT, Carriage, Special
58	172779	1	STEM, Shift
59	118134	1	RING, Retaining
60	154072	1	PINION ASSY., Rev. & II
61	154075	1	PINION ASSY., I & II
62	164294	1	KEY
63	174338	1	SHAFT, Pulley
64	1664241	1	WASHER
65	154462	1	WASHER
66	172981	1	WASHER
67	172982	1	WASHER
68	154087	1	GEAR, Rev.
69	154325	1	WASHER
70	154352	1	REV. GEAR PIN ASSY.
71	928727	1	CAPSCREW, Hex, Flange, Whizlock, 3/8-16 x 1-1/4
72	930245	1	LOCKNUT, Hex, 1/2-20
73	154069	2	FORK, Shift
74	154067	1	SHAFT, Shifter
75	154068	1	SHAFT, Shifter, HI-LO
76	154323	2	SPRING
77	905359	2	BALL, Shiftlock
78	8061048	2	RING, Retaining
79	914687	1	FITTING, Grease
80	157519	1	BEARING, Needle
81	1653120	2	BUSHING
82	154538	1	ROLL PIN ASSY.
83	154084	1	SPACER, Rev. Gear
84	154038	1	WASHER
85	921221	1	CAPSCREW, Hex Hd., 5/16-18 x 1-1/2

NOTE: PARTS REF. NO. 1-50 FOUND ON
PRECEDING PAGE.

TRANSMISSION GROUP

1. Grease inside lips of all seals before installation. Install seals with springs  toward inside.
2. Apply Loctite and torque to 18-23 Ft. Lbs.
3. Adjust carriage bolt to proper height so that safety switch will make contact when transmission is in neutral position.
4. Torque to 55 Ft. Lbs.
5. Torque to 18-23 Ft. Lbs. 
6. Install bearing with land riding seal facing in.
7. Install pin with groove down.
8. Install seal with lip in, grease inside of lip before installation.
9. Apply sealer when assembling shift fork rails into transmission gear case.
10. Seal holes in transmission gear case with sealer when assembling capscrews.
11. Use Standard Hardware Torque Spec. Chart unless otherwise noted.

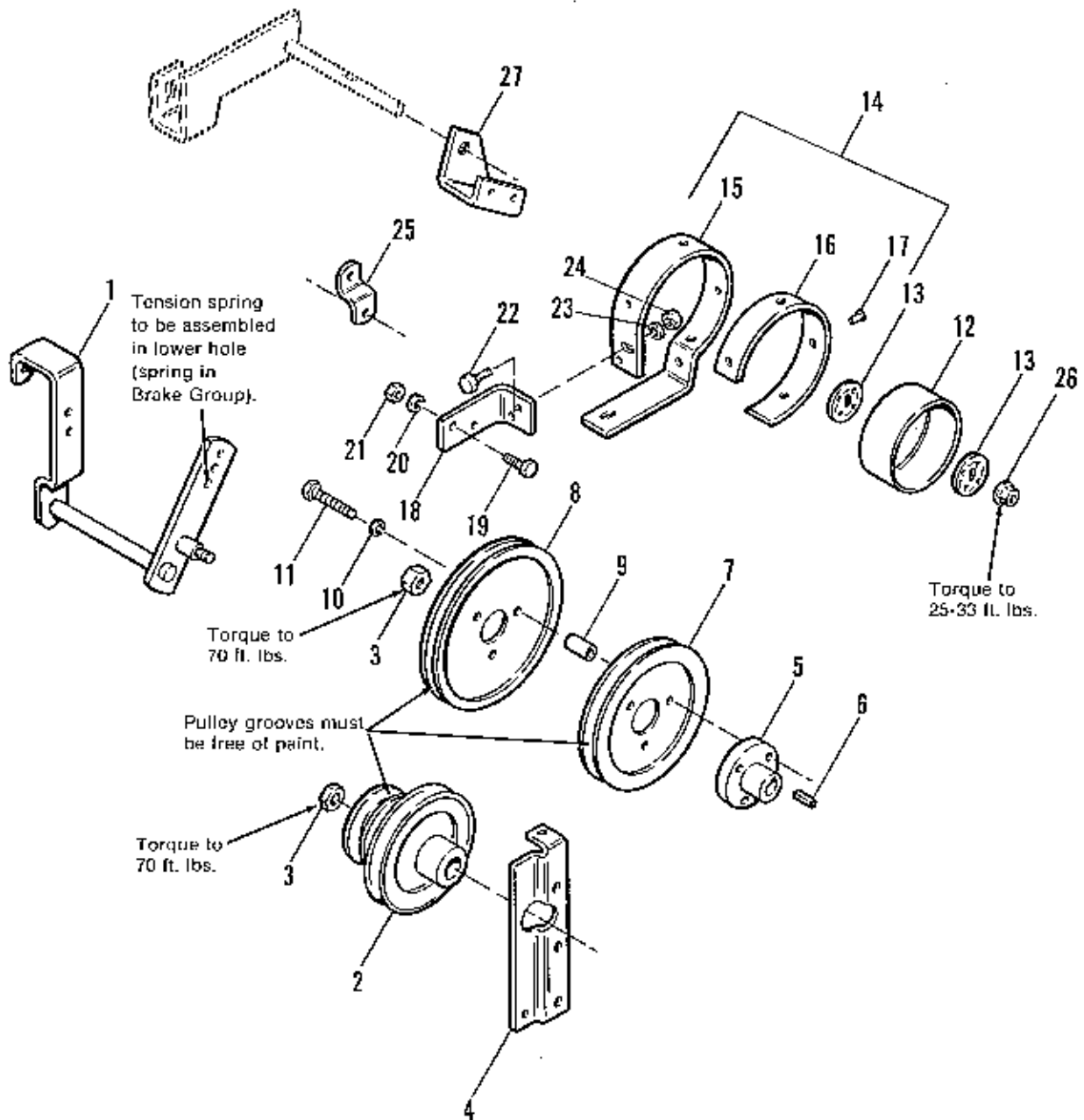

NOTE: Use standard hardware torque spec. chart unless otherwise noted.

Ref. No.	Part No.	Qty.	Description
1	1656459	1	PIVOT LEVER ASSY.
2	1608322	1	FRONT PULLEY ASSY.
3	922133	2	LOCKNUT, Jam, 3/4-16
4	1608304	1	SUPPORT, Belt Retainer
5	1608309	1	HUB, Pulley
6	905123	1	KEY, Woodruff #9
7	1608122	1	SHEAVE
8	174420	1	SHEAVE
9	1608310	3	SPACER
10	917356	3	LOCKWASHER, 5/16
11	921978	3	CAPSCREW, Hex Hd., 5/16-18 x 2
12	157282	1	DRUM, Brake
13	158196	2	WASHER, Special
14	171497	1	BRAKE BAND ASSY.
15		1	BAND, Brake (See Ref. No. 14)
16	154133	1	LINING, Brake
17	907166	4	RIVET, Tubular
18	164113	1	BRACKET, Brake Band
19	920415	2	CAPSCREW, Hex Hd., 3/8-16 x 1-1/4
20	916965	2	LOCKWASHER, 3/8
21	916950	2	NUT, Hex, Full, 3/8-16
22	923341	2	CAPSCREW, Hex Hd., 1/4-20 x 3/4
23	916964	2	LOCKWASHER, 1/4
24	916622	2	NUT, Hex, Full, 1/4-20
25	174893	1	CLIP, Spring
26	930650	1	LOCKNUT, Hex, Flange, Whiz, 7/16-14
27	1607027	1	BEARING, Idler Pivot

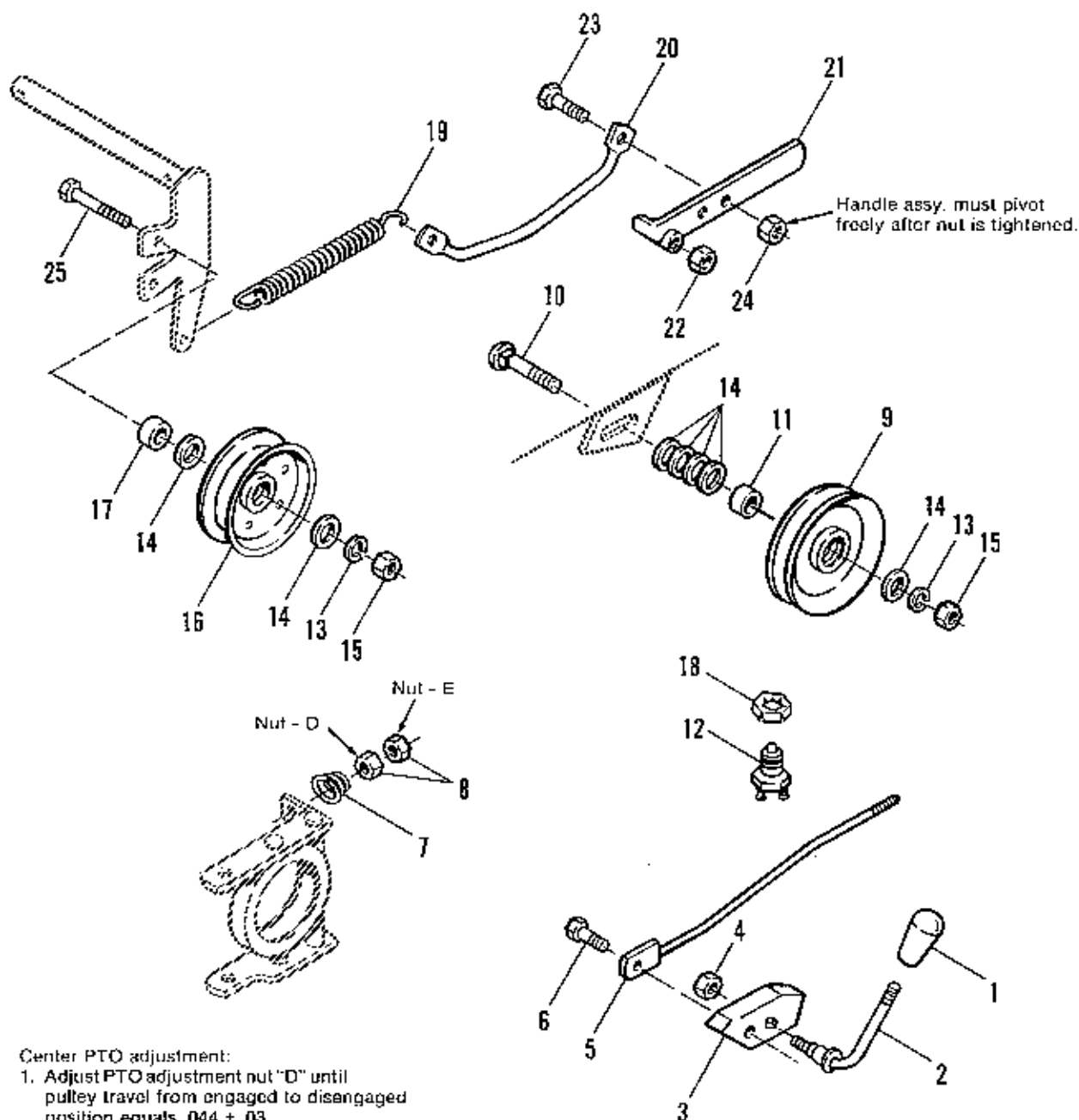

Center PTO adjustment:

1. Adjust PTO adjustment nut "D" until pulley travel from engaged to disengaged position equals $.044 \pm .03$.
2. Secure adjustment by locking nuts "D" and "E" together.
3. Check clutch for proper disengagement.

NOTE: Use standard hardware torque spec. chart unless otherwise noted.

Ref. No.	Part No.	Qty.	Description
1	172038	1	KNOB
2	174664	1	HANDLE, Clutch P.T.O.
3	173991	1	LEVER
4	930651	1	LOCKNUT, Hex, 3/8-16
5	173988	1	CONTROL ROD ASSY.
6	174686	1	CAPSCREW, Special
7	175316	1	SPRING
8	917372	2	NUT, Hex, Full, 5/16-18
9	1665440	1	PULLEY ASSY., W/Bearing
10	931352	1	BOLT, Carriage, 3/8-16 x 1-1/2
11	1666294	1	SPACER
12	177522	1	SWITCH, Interlock
13	916965	2	LOCKWASHER, 3/8
14	917642	7	WASHER, 5/16
15	916950	2	NUT, Hex, Full, 3/8-16
16	1606554	1	PULLEY, Idler
17	157081	1	SPACER
18	930647	1	NUT, Pal
19	1666786	1	SPRING, Tension
20	164047	1	ROD, Tension
21	164155	1	HANDLE ASSY.
22	924058	1	LOCKNUT, Hex, 7/16-14
23	921332	1	CAPSCREW, Hex Hd., 5/16-18 x 3/4
24	923362	1	LOCKNUT, Hex, 5/16-18
25	923701	1	CAPSCREW, Hex Hd., 3/8-16 x 2

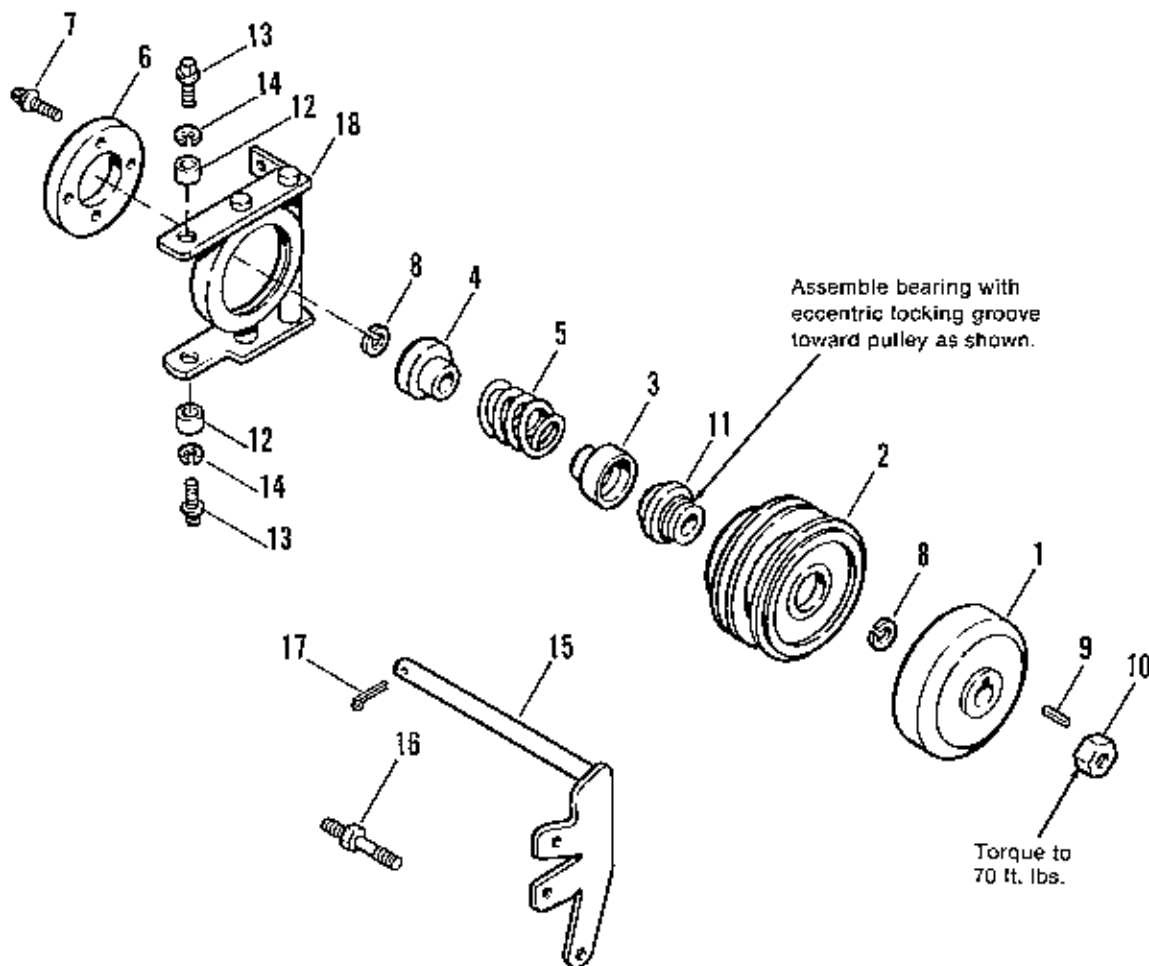

NOTE: Use standard hardware torque spec. chart unless otherwise noted.

Ref. No.	Part No.	Qty.	Description
1	174862	1	CLUTCH PLATE ASSY.
2	1650304	1	PULLEY
3	1650252	1	GUIDE, Spring, Outside
4	1650264	1	GUIDE, Spring, Inside
5	171772	1	SPRING
6	173957	1	DISC, Brake
7	920036	4	CAPSCREW, Skt. Hd., 1/4-20 x 5/8
8	172206	2	RING, Retaining
9	905123	1	KEY
10	922133	1	LOCKNUT, Hex, 3/4 x 16
11	1650254	1	BEARING ASSY.
12	171371	2	SPACER
13	1651450	2	SCREW, Thd. Forming
14	917356	2	LOCKWASHER, 5/16
15	1666781	1	PIVOT ARM ASSY.
16	157273	1	STUD
17	918459	1	PIN, Cotter, 3/16 x 1-1/2
18	1650906	1	PIVOT ASSY.

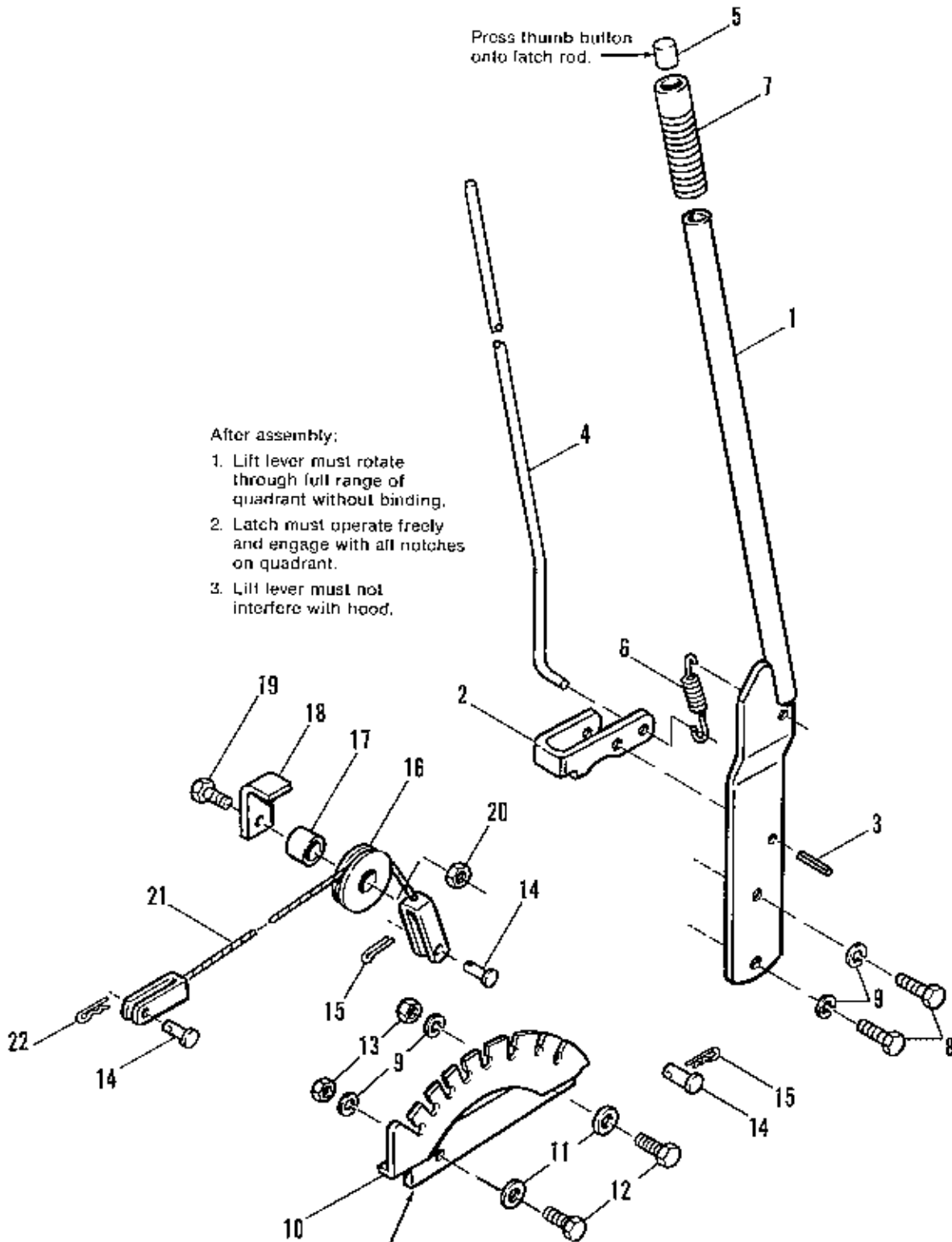

Press thumb button onto latch rod.

- After assembly:
1. Lift lever must rotate through full range of quadrant without binding.
 2. Latch must operate freely and engage with all notches on quadrant.
 3. Lift lever must not interfere with hood.

Mount quadrant on frame. Use slots to center quadrant with lift shaft.

NOTE: Use standard hardware torque spec. chart unless otherwise noted.

Ref. No.	Part No.	Qty.	Description
1	1666257	1	LIFT LEVER ASSEMBLY
2	173038	1	LATCH, Lift Lever
3	918390	1	PIN, Spring, 3/8 x 1-1/4
4	1666663	1	ROD, Latch
5	1650157	1	BUTTON
6	1650155	1	SPRING
7	156209	1	GRIP
8	923490	2	CAPSCREW, Hex Hd., 3/8-16 x 1
9	916965	4	LOCKWASHER, 3/8
10	171599	1	QUADRANT
11	917642	2	WASHER, 5/16
12	921966	2	CAPSCREW, Hex Hd., 3/8-16 x 7/8
13	916950	2	NUT, Hex, Full, 3/8-16
14	153058	3	PIN
15	918196	2	CLIP, Spring
16	172725	1	PULLEY
17	157081	1	SPACER
18	174723	1	GUARD, Cable
19	108418	1	SCREW, Special
20	928731	1	LOCKNUT, Hex, Jam, 3/8-16
21	1666797	1	LIFT CABLE ASSY.
22	916241	1	PIN, Cotter, 3/32 x 7/8

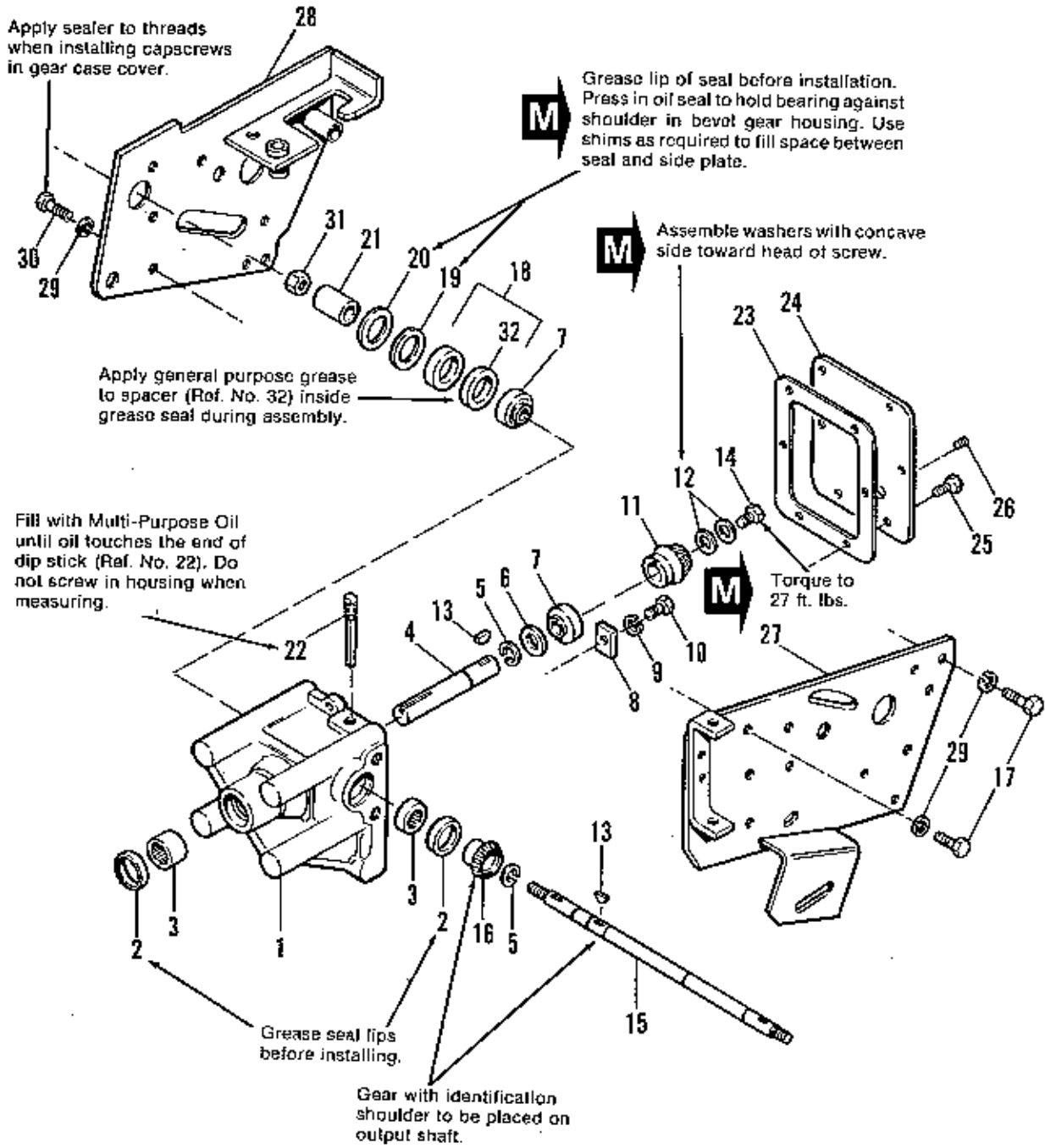

NOTE: Use standard hardware torque spec. chart unless otherwise noted.

Ref. No.	Part No.	Qty.	Description
1	171797	1	HOUSING, Bevel Gear
2	118117	2	SEAL, Oil
3	154279	2	BEARING, Needle
4	172750	1	SHAFT, Driver
5	172206	2	RING, Retaining
6	172753	1	WASHER
7	172256	2	BEARING, Ball
8	154040	1	PLATE, Bearing Clamp
9	917356	1	LOCKWASHER, 5/16
10	925205	1	CAPSCREW, Hex Hd., 5/16-18 x 5/8
11	172752	1	GEAR, Bevel Driver
12	177649	2	WASHER
13	905123	2	KEY, Woodruff #9
14	154281	1	CAPSCREW, Hex Hd., 5/16-18 x 3/4
15	1657178	1	SHAFT, Driven
16	171796	1	GEAR, Bevel Driven
17	920677	2	CAPSCREW, Hex Hd., 7/16-14 x 1-1/4
18	1685088	1	SEAL, Oil Kit
19	171791	1	SHIM
20	171790	5	SHIM
21	171792	1	SPACER
22	178105	1	PLUG ASSY.
23	154282	1	GASKET
24	178104	1	COVER
25	930626	6	CAPSCREW, Hex, 1/4-20 x 5/8
26	901652	1	PLUG, Pipe
27	1666793	1	PLATE ASSY., Side, L.H.
28	1606609	1	PLATE ASSY., Side, R.H.
29	916199	12	LOCKWASHER, 7/16
30	920676	10	CAPSCREW, Hex Hd., 7/16-14 x 1
31	922133	1	LOCKNUT, Hex, Jam, 3/4-16
32	1663111	1	SPACER, Oil Seal

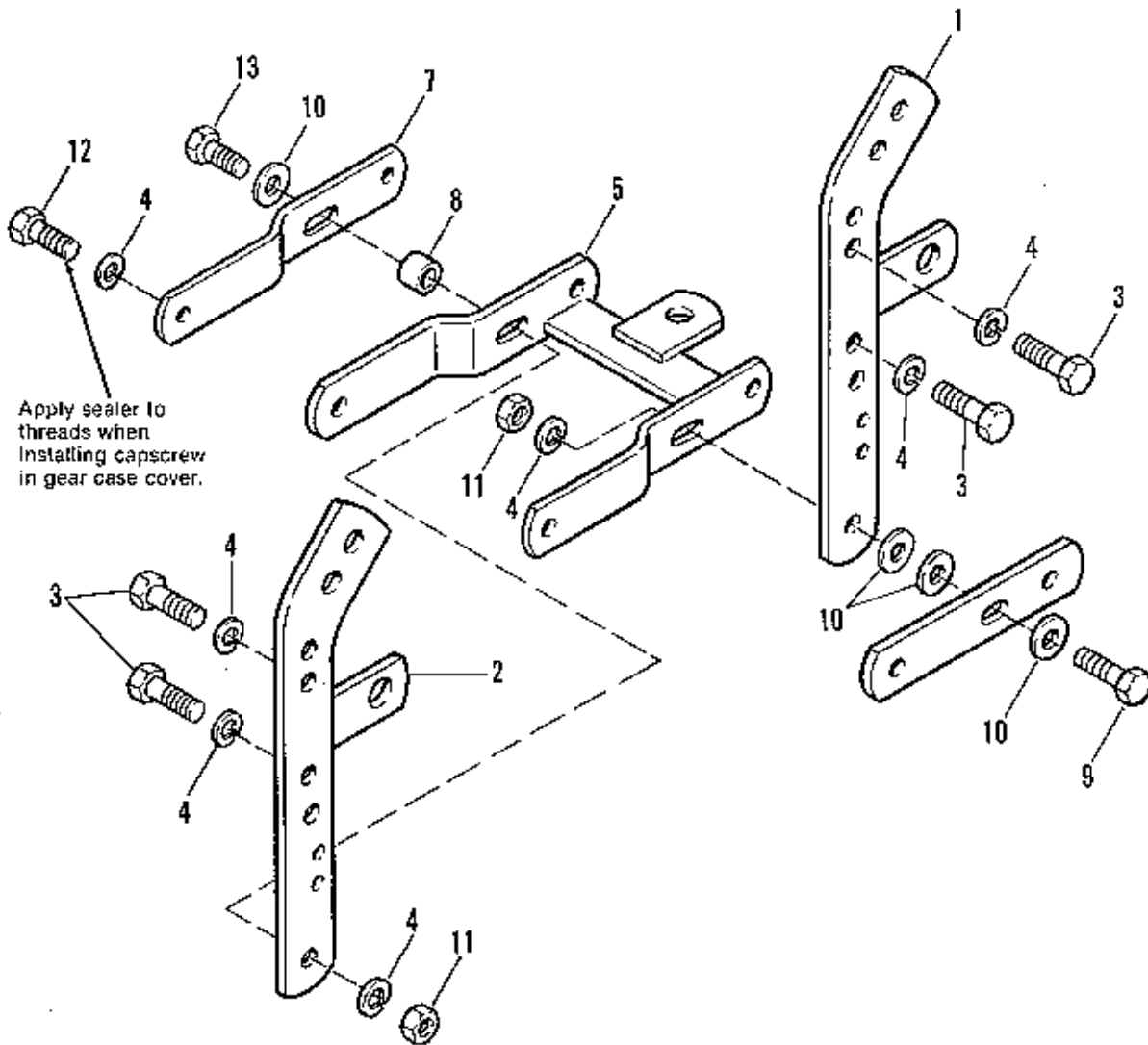

NOTE: Use standard hardware torque spec. chart unless otherwise noted.

Draw Bar Group (7110 & 7116)

Simplicity

7179

Ref. No.	Part No.	Qty.	Description
1	164304	1	ARM ASSY., L.H.
2	164284	1	ARM ASSY., R.H.
3	920676	4	CAPSCREW, Hex Hd., 7/16-14 x 1
4	918199	8	LOCKWASHER, 7/16
5	154202	1	DRAW BAR ASSY.
6	157091	1	BAR, Pull, L.H.
7	154203	1	BAR, Draw, R.H.
8	1608759	1	SPACER
9	920677	1	CAPSCREW, Hex Hd., 7/16-14 x 1-1/4
10	918430	4	WASHER, 7/16
11	918213	2	NUT, Hex, 7/16-14
12	923027	1	CAPSCREW, Hex Hd., 7/16-14 x 1-3/4
13	926109	1	CAPSCREW, Hex Hd., 7/16-14 x 2-1/4

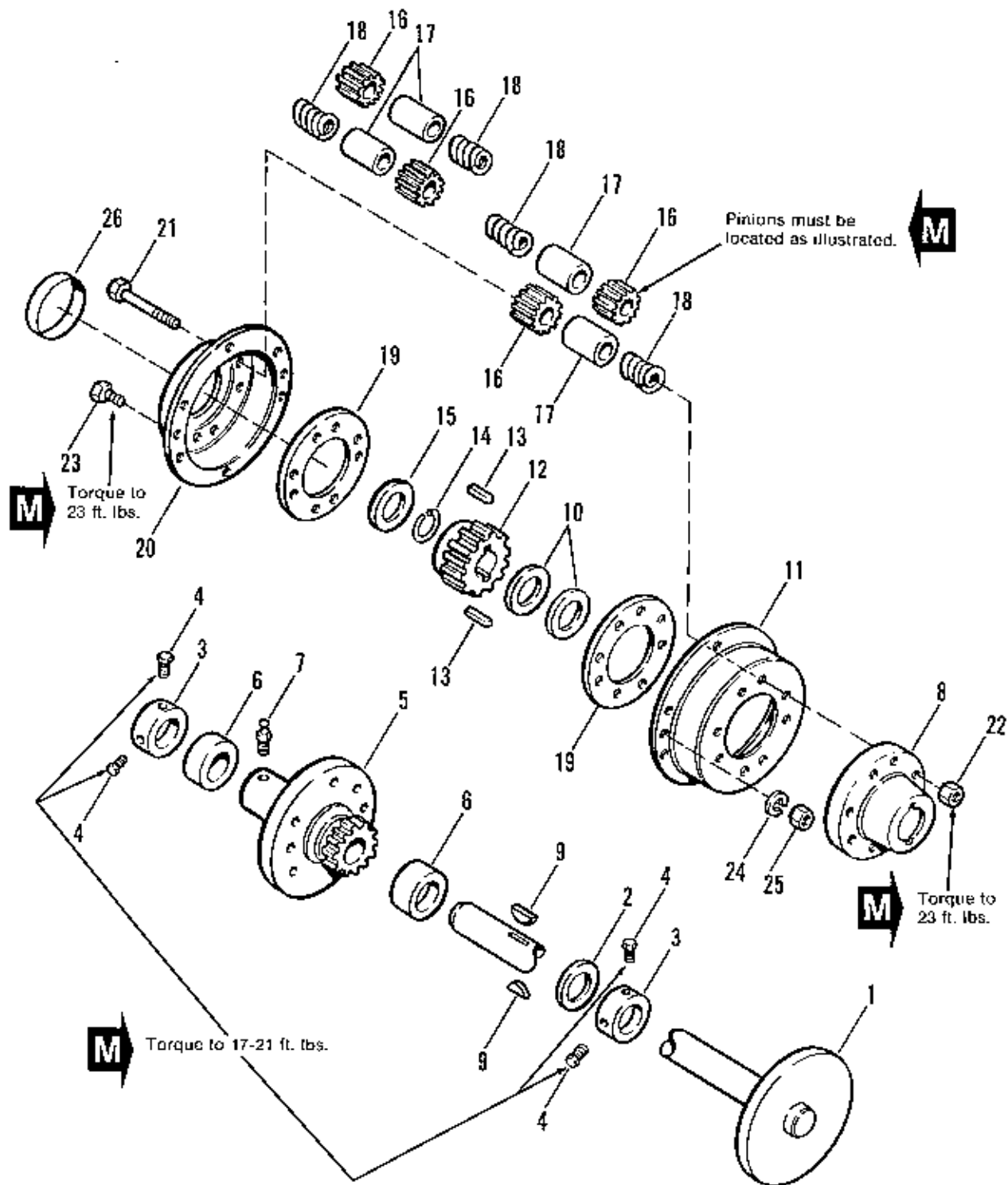

NOTE: Use standard hardware torque spec. chart unless otherwise noted.

Ref. No.	Part No.	Qty.	Description
1	177900	1	REAR AXLE ASSY.
2	105050	1	WASHER
3	154065	2	COLLAR, Set
4	928721	4	SETSCREW, Sq. Hd., 5/16-18 x 1/2
5	176945	1	R.H. WHEEL HUB ASSY.
6	153068	2	BEARING
7	915019	1	FITTING, Grease
8	164217	1	CARRIER, Diff.
9	157120	2	KEY, Drive
10	171515	2	WASHER, Axle
11	171853	1	COVER, Diff.
12	177041	1	GEAR, Diff.
13	930671	2	KEY, Hi Pro, 1/4 x 3/4
14	154291	1	RING, Retaining
15	154277	1	WASHER, Axle
16	158579	8	PINION, Diff.
17	121083	8	SPINDLE, Diff. Pinion
18	162085	8	SPRING
19	171517	2	RING, Spacer
20	171854	1	COVER, Diff.
21	921972	8	CAPSCREW, Hex Hd., 3/8-16 x 2-1/2
22	930651	8	NUT, Hex, 3/8-16
23	921959	6	CAPSCREW, Hex, 1/4-20 x 5/8
24	916964	6	LOCKWASHER, 1/4
25	916622	6	NUT, Hex, 1/4-14
26	121190	1	SEAL, Cover
27	1650519	1	DIFFERENTIAL SUBASSY. (Includes Ref. No's. 8, 11, 16 thru 26)

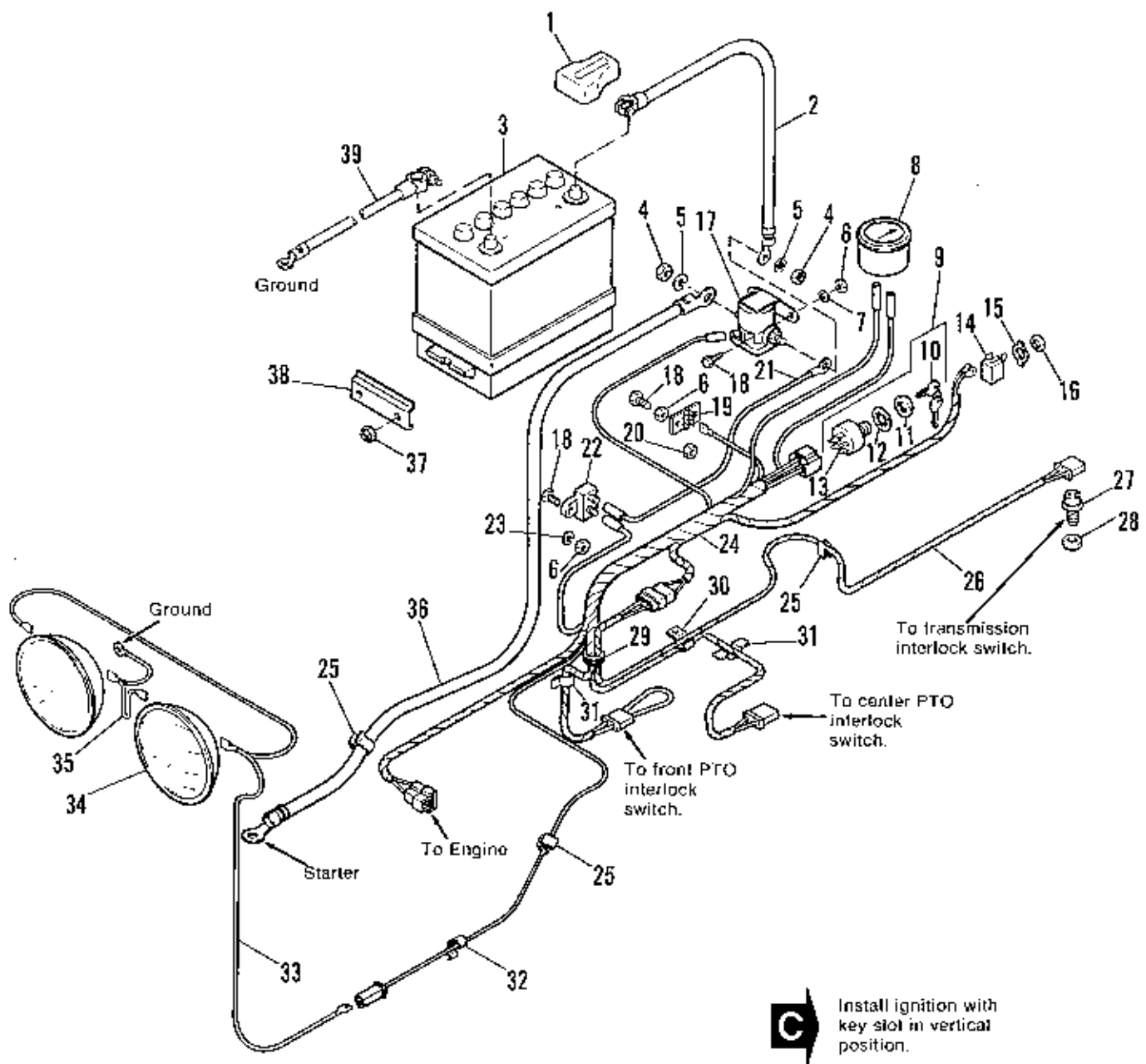

NOTE: Use standard hardware torque spec. chart unless otherwise noted.

Ref. No.	Part No.	Qty.	Description
1	1657339	1	PROTECTOR, Terminal
2	1666235	1	CABLE, Battery to Solenoid
3	1686058	1	BATTERY (includes decal)
4	917372	2	NUT, Hex, 5/16-18
5	917356	2	LOCKWASHER, 5/16
6	916622	5	NUT, Hex, 1/4-20
7	916964	2	LOCKWASHER, 1/4
8	1603189	1	AMMETER
9	1602780	1	SWITCH & KEY ASSY., Ignition
10	1603249	1	KEYS, 2
11	122235	1	NUT, Special
12	918906	1	LOCKWASHER, Internal Tooth, 5/8
13	1666259	1	SWITCH, Ignition
14	122184	1	SWITCH, Toggle
15	1650878	1	PLATE
16	1650880	1	NUT, Switch
17	122216	1	SOLENOID, Starter
18	921959	5	CAPSCREW, Hex Hd., 1/4-20 x 5/8
19	1665230	1	BOARD, Terminal
20	923358	2	LOCKNUT, Hex, 1/4-20
21	1665237	1	WIRE ASSY.
22	1665238	1	CIRCUIT BREAKER
23	921880	1	LOCKWASHER, 1/4
24	1886327	1	HARNESS ASSY.
25	172434	3	CLIP, Tinnerman
26	1665236	1	WIRE ASSY.
27	177522	1	SWITCH, Interlock
28	930647	1	NUT, Pal
29	172175	1	GROMMET
30	932771	1	CLIP, Cable
31	176912	2	CLIP, Wire
32	172436	1	CLIP, Tinnerman
33	1666665	1	WIRE ASSY.
*34		2	LAMP, Sealed Beam, G.E. #4411-1
35	1666731	1	WIRE ASSY.
36	1886328	1	CABLE, Solenoid to Starter
37	924433	2	NUT, Elastic, 5/16-18
38	171225	1	CLAMP
39	171811	1	CABLE, Battery to Ground

*Purchase from your local automotive supplier.

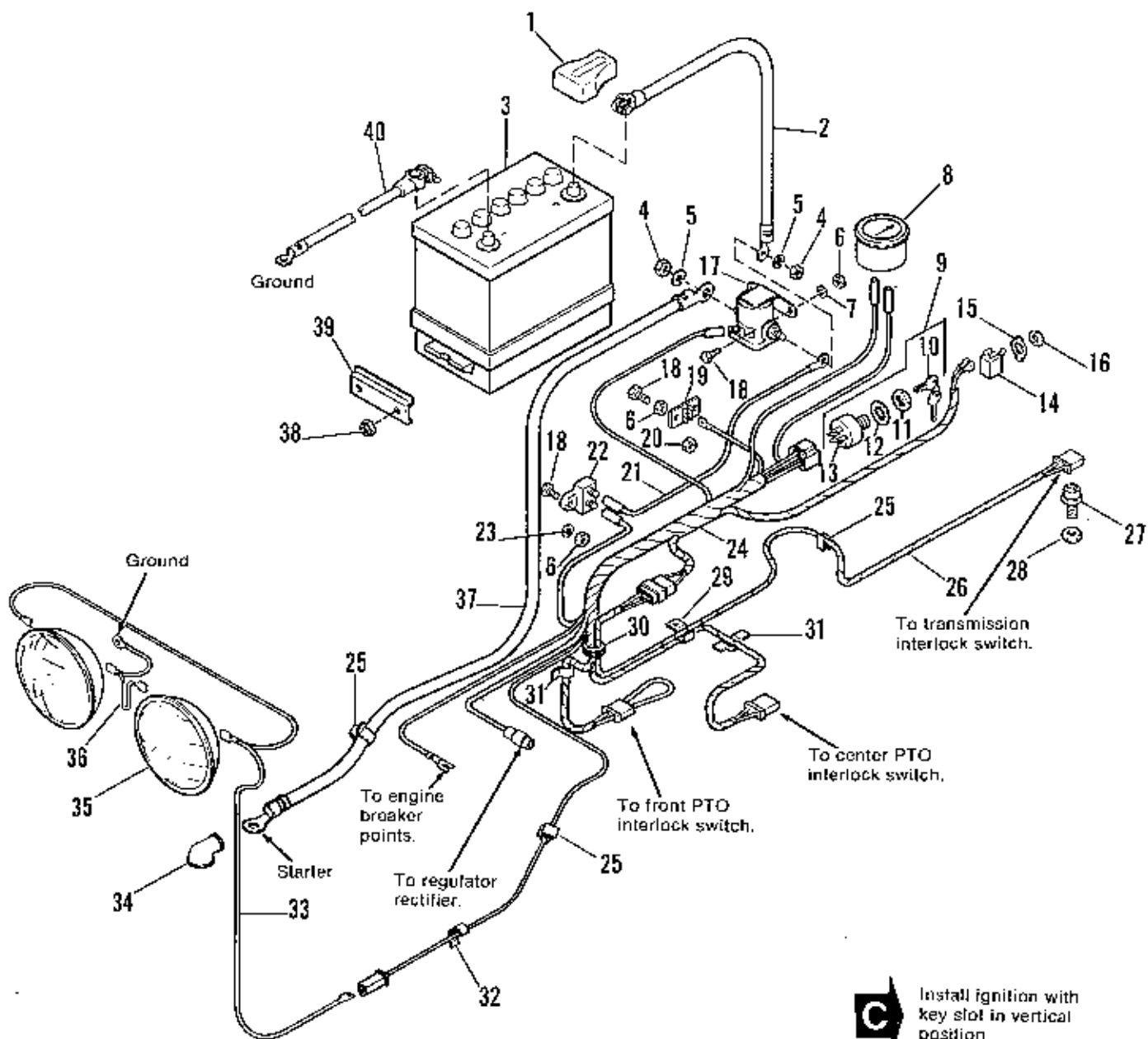

NOTE: Use standard hardware torque spec. chart unless otherwise noted.

Ref. No.	Part No.	Qty.	Description
1	1657339	1	PROTECTOR, Terminal
2	1665235	1	CABLE, Battery to Solenoid
3	1685058	1	BATTERY (includes decal)
4	917372	2	NUT, Hex, 5/16-18
5	917356	2	LOCKWASHER, 5/16
6	916622	5	LOCKNUT, Hex, 1/4-20
7	916964	2	LOCKWASHER, 1/4
8	1603189	1	AMMETER
9	178280	1	SWITCH & KEY ASSY., Ignition
10	122203	1	KEYS, 2
11	122234	1	NUT, Special
12	918906	1	LOCKWASHER, Internal Tooth, 5/8
13	1665250	1	SWITCH, Ignition
14	122184	1	SWITCH, Toggle
15	1650878	1	PLATE
16	1650880	1	NUT, Switch
17	122216	1	SOLENOID, Starter
18	921959	5	CAPSCREW, Hex Hd., 1/4-20 x 5/8
19	1665230	1	BOARD, Terminal
20	923358	2	LOCKNUT, Hex, 1/4-20
21	1665237	1	WIRE ASSY.
22	1665238	1	CIRCUIT BREAKER
23	921880	1	LOCKWASHER, 1/4
24	1666325	1	HARNESS ASSY.
25	172434	3	CLIP, Tinnerman
26	1665236	1	WIRE ASSY.
27	177522	1	SWITCH, Interlock
28	930647	1	NUT, Pal
29	932771	1	CLIP, Cable
30	172175	1	GROMMET
31	176912	2	CLIP, Wire
32	172436	1	CLIP, Tinnerman
33	1666665	1	WIRE ASSY.
34	122023	1	COVER, Terminal
*35		2	LAMP, Sealed Beam, G.E. #4411-1
36	1666731	1	WIRE ASSY.
37	1666328	1	CABLE, Solenoid to Starter
38	924433	2	NUT, Elastic, 5/16-18
39	171225	1	CLAMP
40	171811	1	CABLE, Battery to Ground

*Purchase from your local automotive supplier.

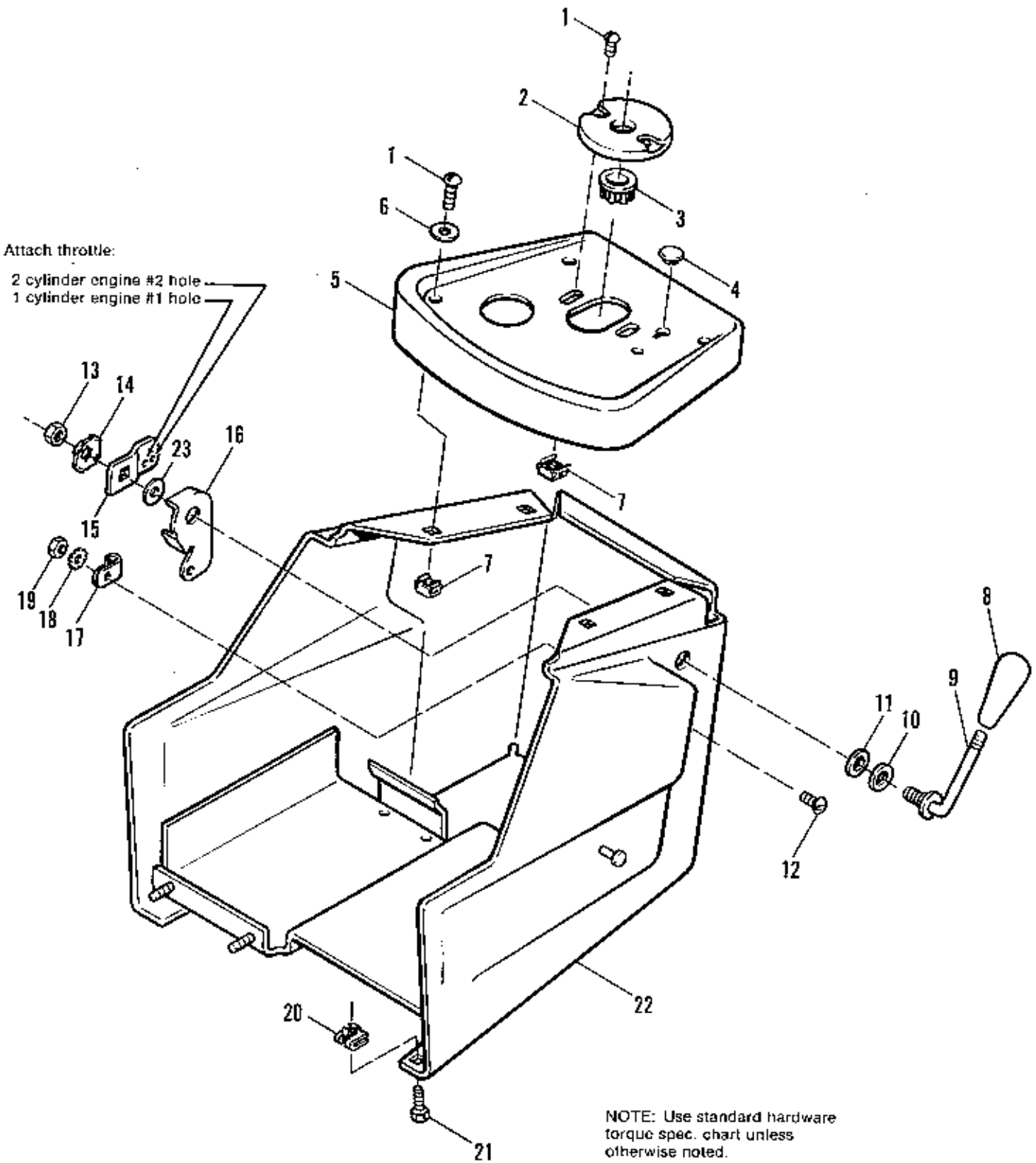

Ref. No.	Part No.	Qty.	Description
1	926025	6	SCREW, Rd. Hd., 1/4-20 x 1/2
2	172008	1	PLATE, Steering
3	157077	1	BUSHING
4	177447	2	BUTTON, Plug
5	1651000	1	PANEL, Instrument
6	916955	4	WASHER, Plain, 3/16
7	917867	6	NUT, Tinnerman
8	172038	1	KNOB, Tapered
9	1651170	1	HANDLE, Clutch Control
10	101025	1	WASHER
11	156116	1	WASHER
12	930531	1	SCREW, Rd. Hd., #10-32 x 1/2
13	930851	1	LOCKNUT, Hex, 3/8-18
14	930665	1	LOCKWASHER, Dished Type Shakeproof, 3/8
15	1666703	1	ARM, Throttle
16	171848	1	STOP, Throttle
17	158475	1	CLIP, Bowden Wire
18	922711	1	LOCKWASHER, External, #10
19	917415	1	NUT, Hex, #10-32
20	928703	6	NUT, Spood, Tinnerman
21	930561	6	SCREW, Hex Hd., #14 x 3/4
22	1665229	1	DASH ASSY.
23	159107	1	WASHER, Nylon

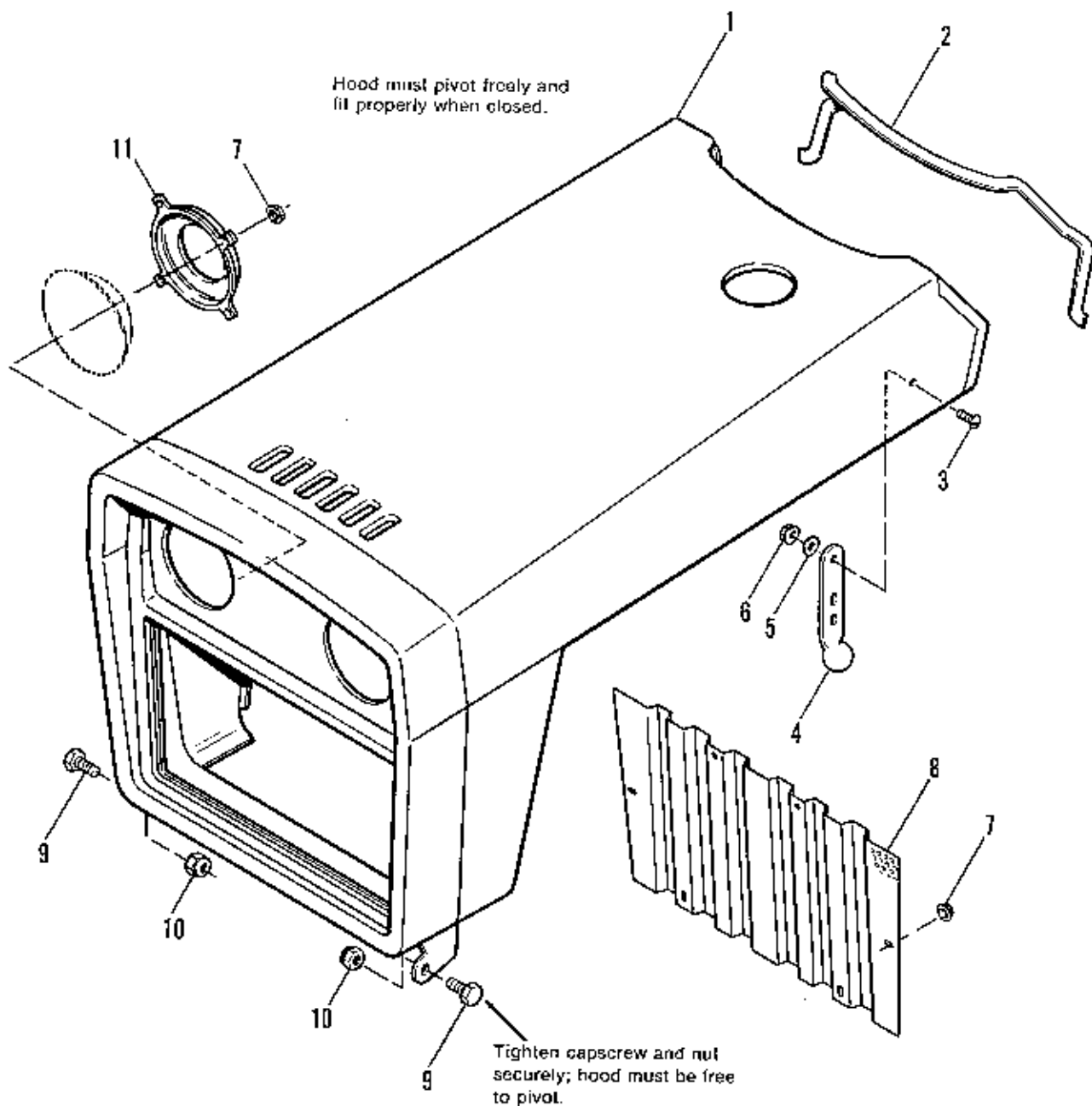

NOTE: Use standard hardware torque spec. chart unless otherwise noted.

Ref. No.	Part No.	Qty.	Description
1	1665945	1	HOOD & GRILLE ASSY.
2	172935	1	MOULDING, Hood
3	930531	2	SCREW
4	171600	2	STRAP, Hood
5	171804	2	WASHER, Special
6	930627	2	LOCKNUT, Hex, #10-32
7	1665253	14	LOCKNUT, Pa1
8	1665148	1	SCREEN
9	921210	2	CAPSCREW, Hex Hd., 3/8-16 x 1
10	923428	2	LOCKNUT, Hex, 3/8-16
11	1665813	2	BRACKET, Headlight Support

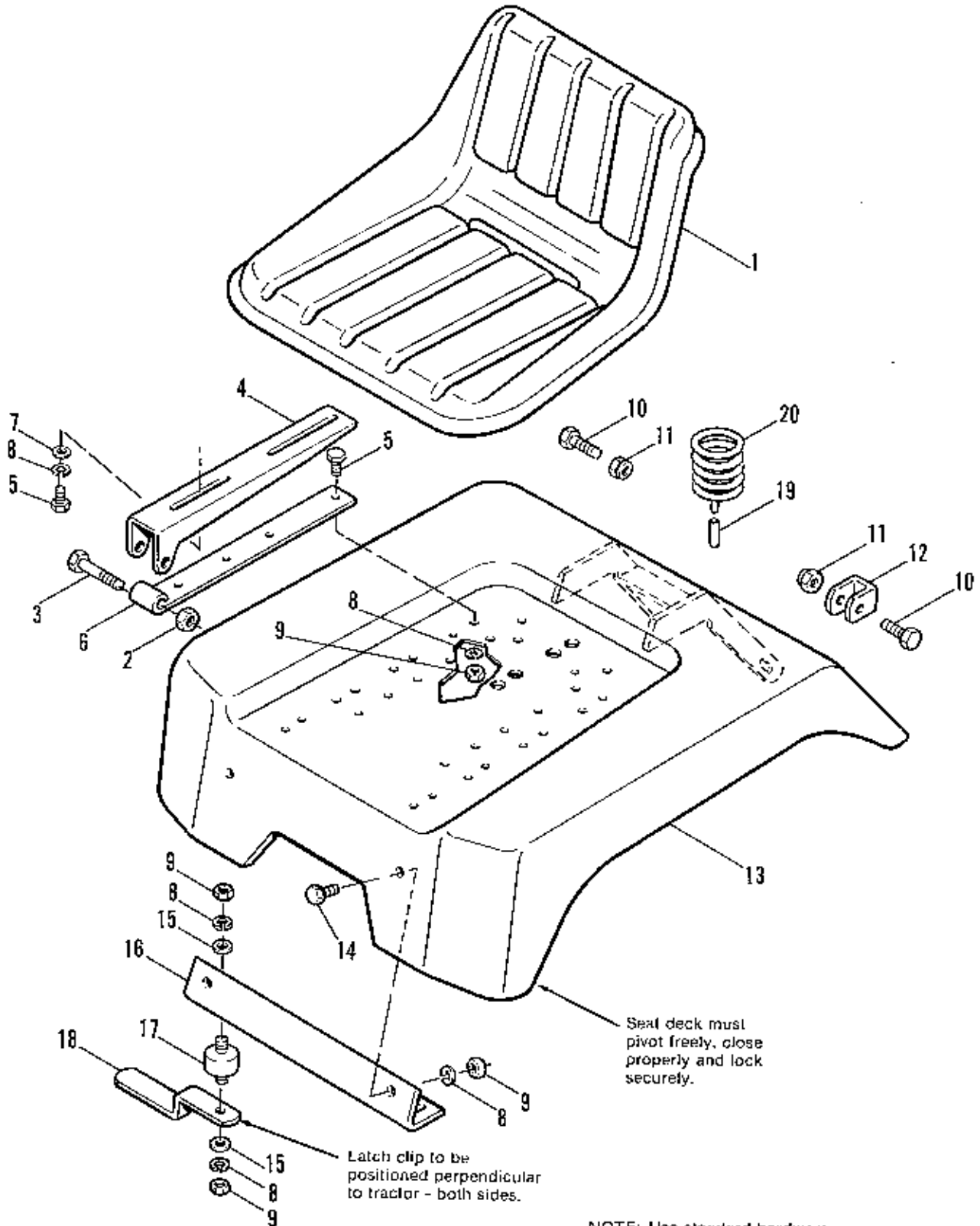

Ref. No.	Part No.	Qty.	Description
1	1665607	1	SEAT
2	923428	2	LOCKNUT, Hex, Full, 3/8-16
3	923701	2	CAPSCREW, Hex Hd., 3/8-16 x 2
4	1666200	2	HINGE, Upper
5	921332	10	CAPSCREW, Hex Hd., 5/16-18 x 3/4
6	1666737	2	HINGE, Lower
7	917642	4	WASHER, Plain, 5/16
8	917356	16	LOCKWASHER, 5/16
9	917372	12	NUT, Hex, 5/16-18
10	920415	2	CAPSCREW, Hex, Hd., 3/8-16 x 1-1/4
11	930651	2	LOCKNUT, Hex, 3/8-16
12	1607870	1	STOP, Seat Deck
13	1666501	1	DECK ASSY., Seat
14	925205	2	CAPSCREW, Hex, Hd., 5/16-18 x 5/8
15	917377	4	WASHER, 1/4
16	164029	1	BRACKET, Front Seat Deck
17	1666744	2	CONNECTOR, Cushion
18	1606823	2	CLIP, Latch
19	1666691	2	COVER, Wire
20	1666690	2	SPRING, Seat

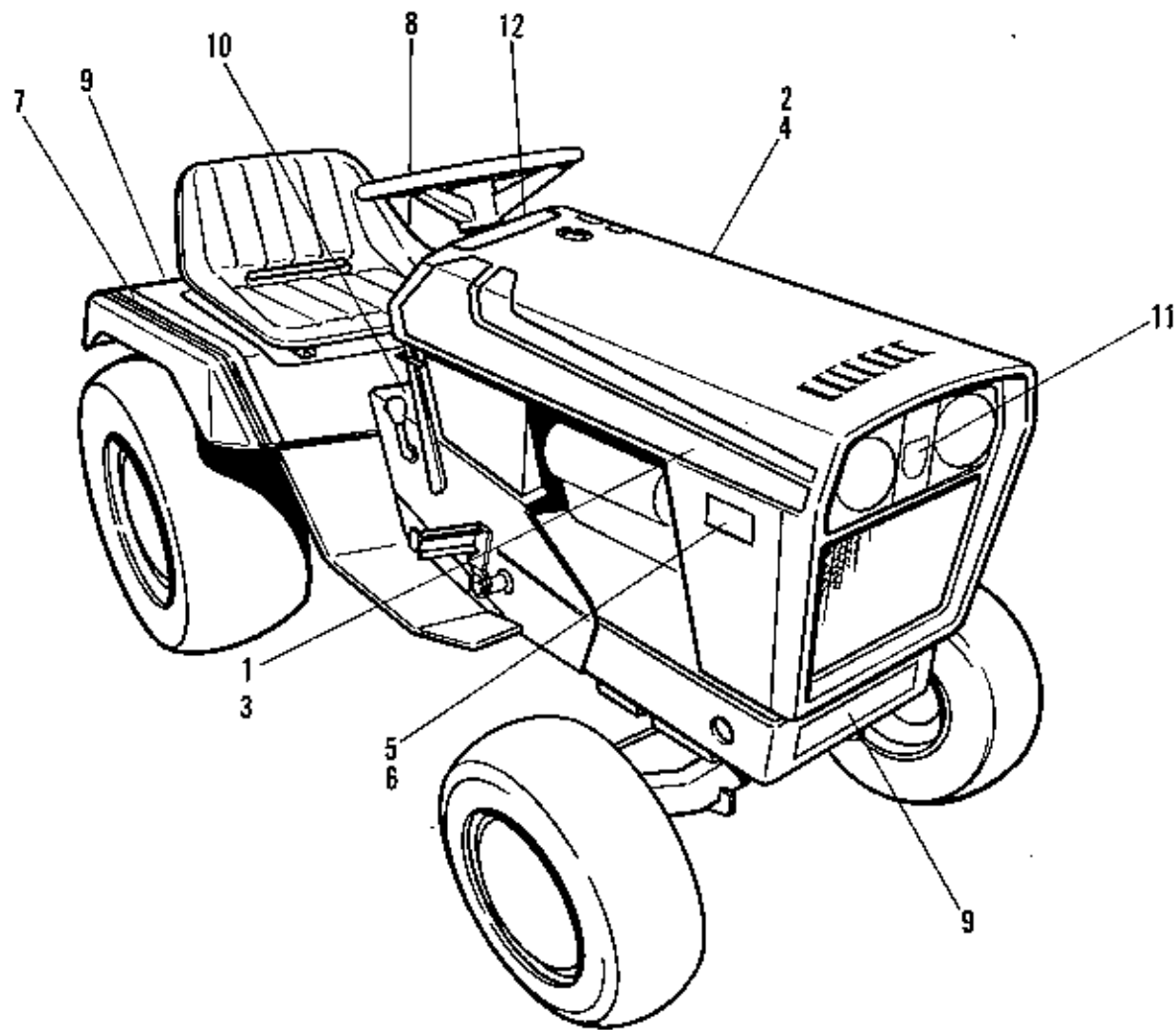

Ref. No.	Part No.	Qty.	Description
1	1666843	1	DECAL, Hood, Landlord, R.H. (7110 Only)
2	1666844	1	DECAL, Hood, Landlord, L.H. (7110 Only)
3	1666839	1	DECAL, Hood, Sovereign, R.H. (7116 Only)
4	1666840	1	DECAL, Hood, Sovereign, L.H. (7116 Only)
5	1666865	2	DECAL, 7110 Six Speed
6	1666868	2	DECAL, 7116 Six Speed
7	1657282	1	DECAL, Seat Deck, R.H.
8	1657283	1	DECAL, Seat Deck, L.H.
9	153166	2	DECAL, Simplicity
10	1666874	1	DECAL, Console, Six Speed
11	1666854	1	DECAL, Simplicity Grille
12	1666871	1	DECAL, Dash, Six Speed
	157096	1	DECAL, Caution (On Top of Engine)
	1666680	1	DECAL, Drive Belts (Inside Hood)
	1666236	1	DECAL, Warning (Under Seat Deck)
	1667175	1	DECAL, Adjustment (Located on left side plate - red & green)

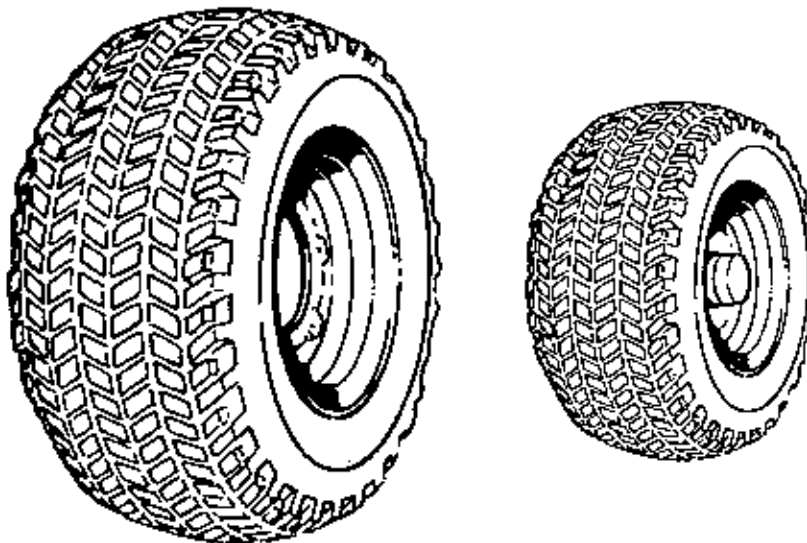
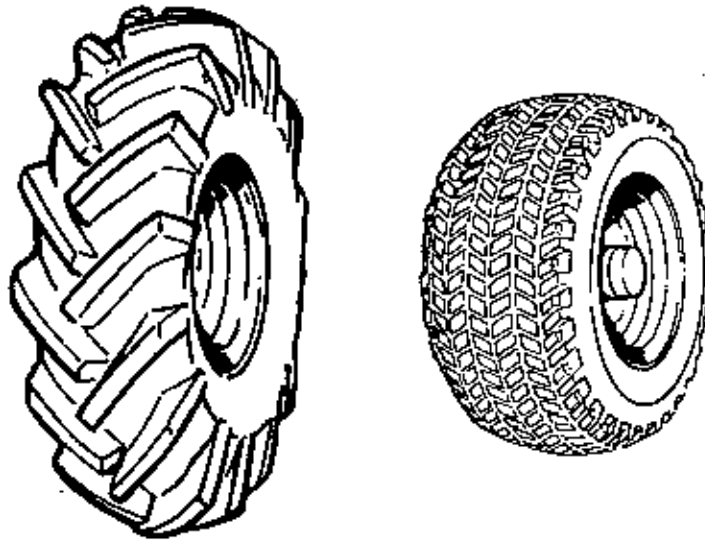

Part No.	Qty.	Description
1657752	1	WHEEL & TIRE ASSY., Rear, R.H., 23 x 10-1/2 - 12, Ag.
1657753	1	WHEEL & TIRE ASSY., Rear, L.H., 23 x 10-1/2 - 12, Ag.
1657694	2	TIRE, 23 x 10-1/2 - 12, Goodyear
157638	2	TUBE
172353	2	VALVE STEM & CAP
173430	2	WHEEL
8261100	10	BOLT, Hub

Part No.	Qty.	Description
171376	2	WHEEL & TIRE ASSY., Front, 16 x 6-1/2 - 8, Turf
156305	2	VALVE STEM & CAP
157490	2	TIRE, Front, Goodyear
164247	2	TUBE
171377	2	WHEEL SUBASSY. (Includes Bearing)
154393	2	CUP, Bearing

Mfg. No. 1690472, 1690475



Turf Tire & Wheel Group (7110 & 7116)

Part No.	Qty.	Description
173431	2	WHEEL & TIRE ASSY., Rear, 23 x 8-1/2 - 12, Turf (Mfg. No. 1690472)
173432	2	WHEEL & TIRE ASSY., Rear, 23 x 10-1/2 - 12, Turf (Mfg. No. 1690475)
157024	2	TIRE, Rear, Goodyear (Mfg. No. 1690472)
157637	2	TIRE, Rear, Goodyear (Mfg. No. 1690475)
157062	2	TUBE (Mfg. No. 1690472)
157638	2	TUBE (Mfg. No. 1690475)
172353	2	VALVE STEM & CAP
173430	2	WHEEL, Drive
8261100	10	BOLT, Hub

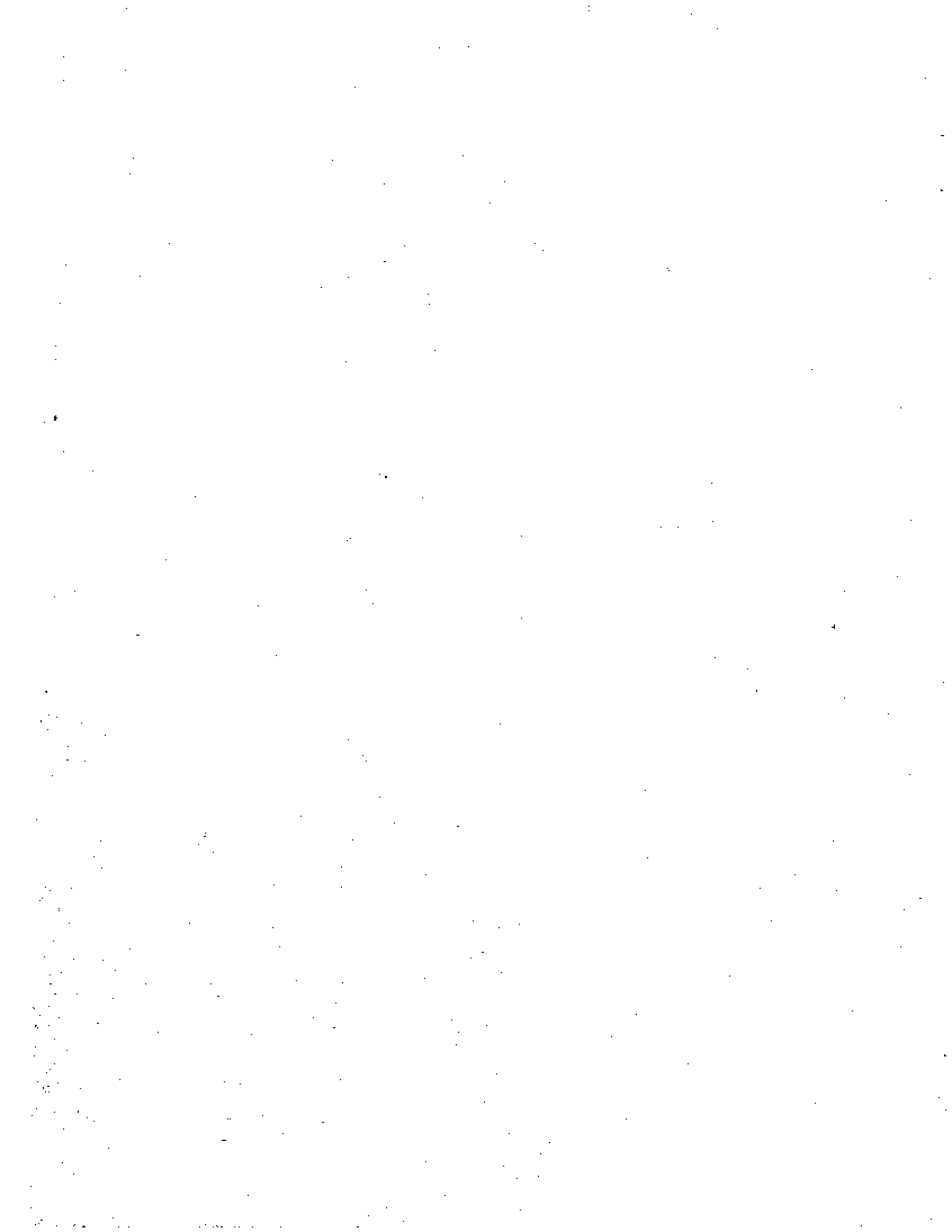
Part No.	Qty.	Description
171376	2	WHEEL & TIRE ASSY., Front, 16 x 6-1/2 -8, Turf
156305	2	VALVE STEM & CAP
157490	2	TIRE, Front, Goodyear
164247	2	TUBE
171377	2	WHEEL SUBASSY. (Includes Bearing)
154393	2	CUP, Bearing



**TORQUE SPECIFICATIONS FOR
STANDARD MACHINE HARDWARE
TOLERANCE $\pm 10\%$**

SIZE	SAE GRADE #2		SAE GRADE #5		SAE GRADE #8	
						
8-32	19	In. Lbs.	30	In. Lbs.	41	In. Lbs.
8-36	20	"	31	"	43	"
10-24	27	"	43	"	60	"
10-32	31	"	49	"	68	"
1/4-20	66	"	8	Ft. Lbs	12	Ft. Lbs.
1/4-28	76	"	10	"	14	"
5/16-18	11	Ft. Lbs	17	"	25	"
5/16-24	12	"	19	"	25	"
3/8-16	20	"	30	"	45	"
3/8-24	23	"	35	"	50	"
7/16-14	30	"	50	"	70	"
7/16-20	35	"	55	"	80	"
1/2-13	50	"	75	"	110	"
1/2-20	55	"	90	"	120	"
9/16-20	65	"	110	"	150	"
9/16-18	75	"	120	"	170	"
5/8-11	90	"	150	"	220	"
5/8-18	100	"	180	"	240	"
3/4-10	160	"	260	"	386	"
3/4-16	180	"	300	"	420	"
7/8-9	140	"	400	"	600	"
7/8-14	155	"	440	"	660	"
1-8	220	"	580	"	900	"
1-12	240	"	640	"	1,000	"

NOTES:

1. These torque values are to be used for all Simplicity hardware excluding: locknuts, self-tapping screws, thread forming screws, and sheet metal screws.
2. Unless otherwise noted on assembly drawings all torque values must meet this specification.

**BOLT HEAD MARKING
S.A.E. GRADE:**



Simplicity Mfg. Co.
500 N. Spring Street
Port Washington, WI 53074