

Simplicity
AN ALLIS-CHALMERS COMPANY

OPERATOR'S MANUAL

MODEL 7018H

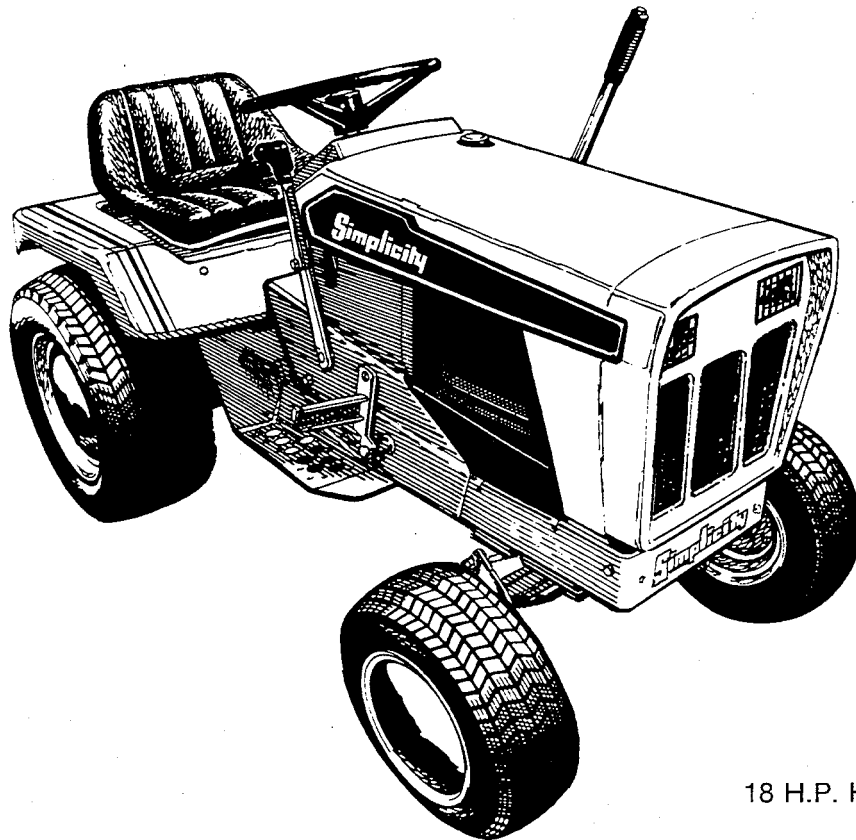

18 H.P. HYDROSTATIC TRACTOR
WITH TURF TIRES
MFG. NO. 1690431
18 H.P. HYDROSTATIC TRACTOR
WITH AGRICULTURAL TIRES
MFG. NO. 1690433



**CAUTION: Read Manual Thoroughly
Before Operating Tractor**

Dear Customer,

Congratulations on your selection and purchase of this tractor. It has been carefully designed and constructed to provide you with years of dependable service. This tractor has been built to meet or exceed current Outdoor Power Equipment Institute (OPEI) safety standards, according to American National Safety Institute (ANSI) Safety Specification B71.1b - 1977, and has been certified by an independent testing laboratory. With proper use and care, this tractor will help you do all your jobs efficiently.

To ensure yourself of the utmost value and performance from this tractor, read this manual carefully. Make sure that your tractor is adjusted properly and operated correctly. Be sure that you (and anyone who operates this machine) know how to use the machine safely. Be thoroughly familiar with all controls and procedures before actual operation.

Also, carefully read and follow the safety rules in this manual and those in your attachment manuals. Review this safety information often; it is there for your benefit and it is important.

This manual provides you with step-by-step operation, normal care, troubleshooting, and adjustment procedures for your tractor. If help is needed with any of these procedures however, your dealer will be happy to assist you.

Measurements are given in this manual with metric equivalents in parentheses. For example, behind the measurement 1/8 inch will appear: (3 mm). So, the metric equivalent of 1/8 inch is 3 millimetres.

These metric measurements are provided for your convenience as an aid in converting to the metric system. A list of metric terms and abbreviations is given below.

LIST OF ABBREVIATIONS OF METRIC TERMS

m	=	metres
mm	=	millimetres
L	=	litres
km/h	=	kilometres per hour
kPa	=	kiloPascals
ml	=	millilitres
kW	=	kilowatts
cc	=	cubic centimetres
kg	=	kilograms
°C	=	degrees Celsius

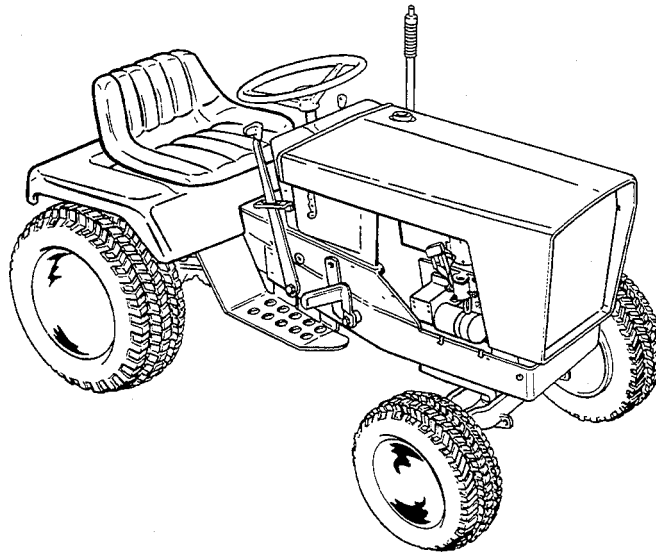
7018H TRACTOR**Table of Contents**

SAFETY RULES	2
OWNER BENEFITS	4
ATTACHMENTS & ACCESSORIES	5
TRACTOR IDENTIFICATION	6
OPERATION	7
CONTENT OF SECTION	7
TRACTOR CONTROLS	7
OPERATING PROCEDURES	8
MAINTENANCE RECORD	12
NORMAL CARE	13
CONTENT OF SECTION	13
SCHEDULED CARE	13
NORMAL STORAGE	13
OFF-SEASON STORAGE	13
STARTING AFTER STORAGE	14
TROUBLESHOOTING	21
CONTENT OF SECTION	21
TROUBLESHOOTING PROCEDURES	21
BATTERY	23
DRIVE BELT REPLACEMENT	24
ADJUSTMENTS	25
CONTENT OF SECTION	25
ADJUSTMENT PROCEDURES	25
ASSEMBLY	29
ELECTRICAL SCHEMATIC	30
SPECIFICATIONS	31
ATTACHMENT OPERATION CHART	33



WARNING

Read these safety rules and follow them closely. Failure to obey these rules could result in loss of control of vehicle, severe personal injury to yourself or bystanders, or damage to property or equipment affecting safety.

Safety Rules



This notation preceding Cautions and Warnings in the text signifies important precautionary steps which, if not properly followed, could result in personal injury or damage to your equipment affecting safety.

-
- General**
- Read the Operator's Manual carefully. Be thoroughly familiar with the controls and the proper use of the equipment.
 - Never allow children to operate the machine. Do not allow adults to operate it without proper instruction.
 - Do not carry passengers.
 - Use only attachments or accessories designed for your machine. See your dealer for a complete list of recommended attachments or accessories.
 - Keep the area of operation clear of all persons, particularly small children, and pets.
 - Never direct discharge of material toward bystanders or allow anyone near the vehicle while in operation.
 - Make sure:
 - a. tractor and attachments are in good operating condition,
 - b. all safety devices and shields are in place and in good working condition, and
 - c. all adjustments have been made.
-
- Preparation**
- Handle gasoline with care - it is highly flammable.
 - a. Use approved gasoline container.
 - b. Never remove the cap of the fuel tank or add gasoline to a running or hot engine, or fill the fuel tank indoors. Wipe up spilled gasoline.
 - Do not run the engine indoors. Exhaust fumes are deadly.
 - Clear the work area of objects which might be picked up and thrown by attachments.
 - Disengage all attachment clutches and shift into neutral before attempting to start the engine.
 - Wear heavy footwear. Do not operate tractor when barefoot or when wearing open sandals or canvas shoes.
-
- Operation**
- Disengage power to attachment(s), stop tractor engine, shift into neutral, set parking brake, and remove the key before leaving the operator's position for any reason, such as to unclog attachment chutes or to make repairs or adjustments.
 - Stop tractor and attachments and inspect for damage after striking a foreign object. Repair any damage before restarting and operating the equipment.
 - Watch out for traffic when crossing or near roadways.

- When using the tractor with attachments, proceed as follows.
 - a. Operate only in daylight or in good artificial light.
 - b. Never make any adjustment while the engine is running.
 - c. Check all hardware, especially mower blade mounting bolts, for tightness at frequent intervals.
- Operate only up and down the face of slopes; never across the face. Do not stop or start suddenly on slopes.
- Reduce speed on slopes and in sharp turns to prevent tipping or loss of control. Use extreme caution when changing direction on slopes.
- Be especially careful not to touch tractor or attachment parts which might be hot from operation. Allow such parts to cool before attempting to maintain, adjust, or service.
- Stay alert for holes in the terrain and other hidden hazards. Be extra careful when operating on wet or slippery surfaces.
- If equipment begins to vibrate abnormally, disengage power to attachments and stop engine at once. Inspect for damage and correct before starting up tractor.
- Use care when pulling loads or using heavy equipment.
 - a. Use only drawbar hitch point.
 - b. Limit loads to those you can safely control.
 - c. Do not turn sharply. Use care when backing.
 - d. Use weights when recommended in the tractor or attachment Operator's Manual.
- Disengage power to attachment (s) when transporting or not in use.
- Take all possible precautions when leaving the vehicle unattended, such as disengaging the power take-off, lowering the attachments(s), shifting into neutral, setting the parking brake, stopping the engine, and removing the key.

Maintenance and Storage

- Keep all nuts, bolts, and screws tight to be sure the equipment is in safe working condition.
- Do not change the engine governor settings or overspeed the engine.
- To reduce fire hazard, keep the engine free of grass, leaves, and excess grease.
- Never store the equipment with gasoline in the tank inside a building where fumes may reach an open flame or spark. Allow the engine to cool before storing in any enclosure.

ALL WARNING, CAUTION, and instructional messages on your tractor and attachments should be carefully read and obeyed. Personal bodily injury can result when these instructions are not followed. The information is for your safety, and it is important. The following are among those on your tractor.

CAUTION
DISCONNECT GROUND (-) TERMINAL WHEN WORKING ON ELECTRICAL SYSTEM TO PREVENT SHORT CIRCUIT

LOCATION: On Engine Near Ground Wire

WARNING: WHEN PARKING ON HILL, SET PARKING BRAKE. DO NOT RELY ON TRANSMISSION TO HOLD TRACTOR.

LOCATION: On Top Frame Near Seat

FOR YOUR SAFETY

TO START ENGINE-SPEED LEVER MUST BE IN NEUTRAL AND PTO DISENGAGED.
 KEEP PEOPLE AND PETS A SAFE DISTANCE AWAY FROM MACHINE.
 KEEP ALL SHIELDS IN PLACE.
 KEEP HANDS, FEET AND CLOTHING AWAY FROM POWER DRIVEN PARTS.
BEFORE LEAVING OPERATORS POSITION

1. Shift transmission to neutral
2. Set parking brake
3. Disengage PTO clutch
4. Shut off engine and remove key
5. Wait for all movement to stop before servicing machine

LOCATION: On Top Frame Near Seat

Owner Benefits

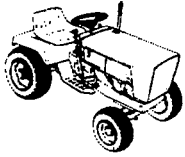

Easy steering — the all-gear steering system is designed to give reliable, fast steering for maneuverability and long life. The short turning radius allows operation around tight corners and in confined areas.

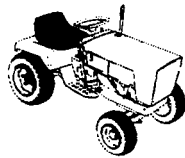

Adjustable 4-position leatherette bonded foam seat helps provide a comfortable, smooth ride.

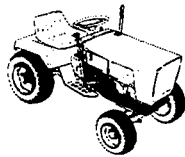

Heavy gauge electrically welded frame of sturdy channel construction takes on rugged jobs with dependable long life operation.

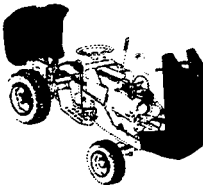

Forward tilting hood and grille makes engine compartment accessible for repairs and maintenance. **Rearward tilting seat** provides access to drive train.

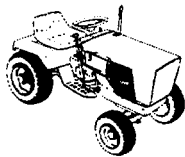

Dependable, air-cooled, balanced engine with mechanical governor offers smooth engine performance under varying load conditions.

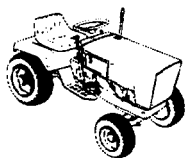

Combined clutch and brake pedal helps ensure safe starting and stopping with easy rocker action.

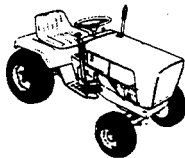

Large wide turf tires give comfortable ride and help protect lawns.

Conveniently located parking brake holds tractor still when tractor is unattended.

Dash-mounted operating controls are accessible and provide quick, finger-tip response.

Hydrostatic transaxle permits selection of any speed from a slow crawl to the maximum in both forward and reverse directions.

7018H Tractor

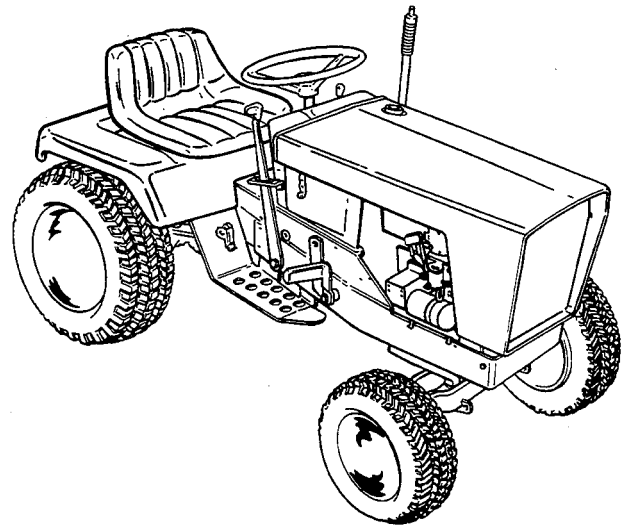

Fast starting under most weather conditions with heavy duty 12 volt electric starter and 45 ampere, automotive rated battery. Ammeter included as standard equipment.

Limited slip differential allows traction even when one of the wheels is on a slippery surface.

Accessories

Many optional accessories are available for your tractor to help it perform better or to make it easier to operate when using various attachments. See your dealer to purchase any of the following accessories.

WHEEL WEIGHTS
REAR LIGHT KIT
POWER LIFT KIT
DUAL LIFT LEVER
REAR LIFT KIT

TIRE CHAINS
HOURMETER
REAR BALL HITCH
HUB CAPS

Attachments

To make your tractor more useful to you, a complete line of attachments is available. See your dealer to purchase any of the following.

42" & 48" ROTARY MOWERS
P.T.O. VACUUM COLLECTOR
42" & 48" VACUUM COLLECTOR ADAPTERS
ROVING NOZZLE FOR VACUUM COLLECTOR
DUMP CART
DUMP CART COVER
38" HEAVY DUTY TILLER
10" MOLDBOARD PLOW
ONE POINT HITCH

540 RPM POWER TAKE OFF
36" & 42" ROTARY SNOW THROWERS
42" & 46" SNOW PLOW AND DOZER BLADES
SNOW CAB
36" ROTARY TILLER
42" GRADER BLADE
SPRING TOOTH HARROW
CULTIVATOR

Tractor Identification

When ordering replacement parts for your tractor, be prepared to give your dealer the identification numbers found on the tractor and engine identification plates shown below. The identification plate for the tractor is located on the frame in front of the tractor seat. The identification plate for the engine is located on the engine blower housing. We suggest that you locate the numbers and record them below for easy reference.

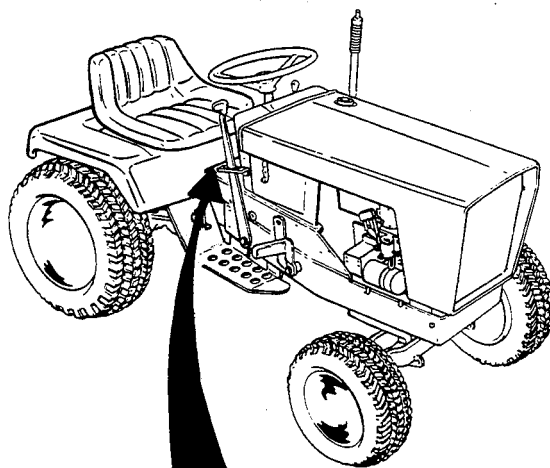

SIMPLICITY MANUFACTURING CO.
A DIVISION OF ALLIS-CHALMERS CORPORATION
PORT WASHINGTON, WI U.S.A.
Refer to ID no. when writing or ordering parts
ID NO.

TRACTOR IDENTIFICATION PLATE

18 H.P.
KOHLER

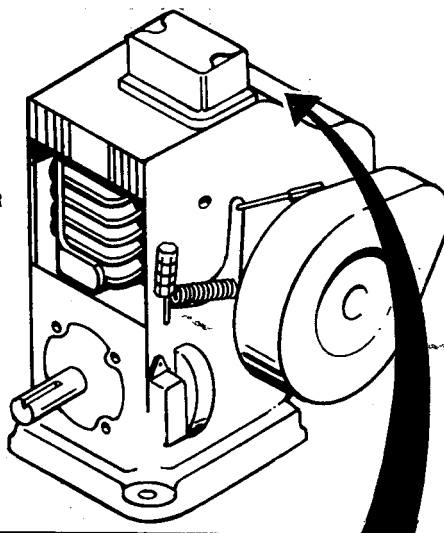

MODEL NO.
SPECIFICATION NO.
SERIAL NO.

7018H ENGINE IDENTIFICATION PLATE

Operation

CONTENT OF SECTION

This section begins with a brief description of the tractor controls, followed by the basic tractor operating procedures.

TRACTOR CONTROLS

Figure 1 shows the locations, names, and functions of the standard tractor controls. Figure 2 gives the same information for optional controls.

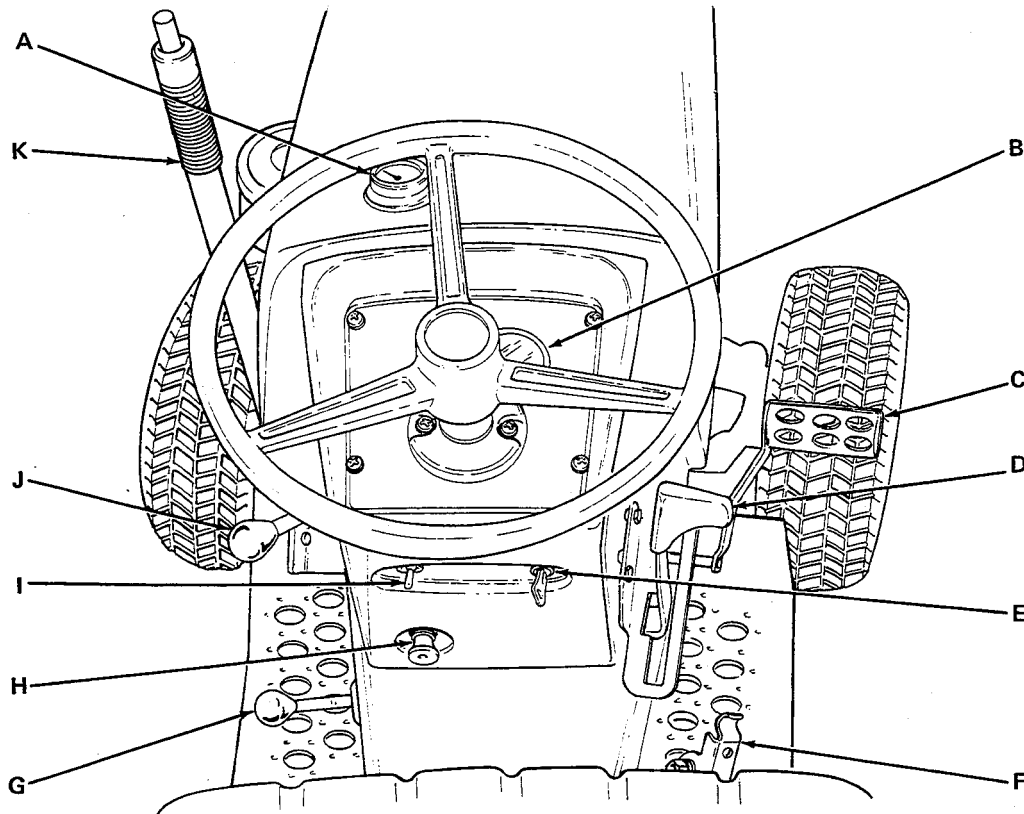

Item	Name	Function
A	Fuel Gauge	Shows fuel level and serves as cap for fuel tank.
B	Ammeter	Shows when battery is being charged or discharged.
C	Clutch-Brake Pedal	Controls both main clutch and brake. Disengages clutch when pressed down at least halfway. Applies brake when fully depressed.
D	Transmission Control Lever	Varies amount and direction of fluid flow in hydrostatic transmission to control speed and direction of tractor motion.
E	Ignition Switch	Operates with key to start, run, or stop engine.
F	Parking Brake Lever	Locks brake to hold tractor in parked position.

Item	Name	Function
G	PTO (Power Take Off) Clutch Lever	Operates clutch for power driven attachments. Used to turn center and rear mounted attachments on and off.
H	Choke Control	When pulled out, closes engine choke for starting and warmup when engine is cold.
I	Light Switch	Switches tractor headlights on or off.
J	Engine Speed Control	Operates engine throttle to adjust engine speed.
K	Lift Lever	Lifts and locks attachments such as the rotary mower in transport position. Pushbutton atop lever opens lock to lower attachment to work position.

Figure 1. Locations and Functions of Standard Tractor Controls

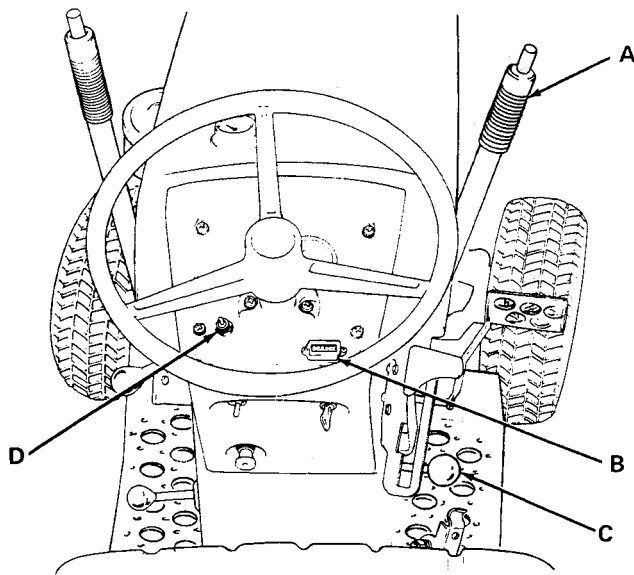

Item	Name	Function
A	Dual Lift Lever	Provides lift control for front-mounted attachments. Used with standard lift lever (item K, figure 1) to provide separate control for two attachments at same time.
B	Hourmeter	Records tractor engine operating hour to help ensure regular care.
C	Front PTO (Power Take Off) Lever	Operates clutch for snow thrower attachment. Used to turn this front mounted attachment on and off.
D	Power Lift Switch	Controls optional electrically operated power lift. When this control is present, the lift lever (item K, figure 1) is removed. The ratchet portion of the lift lever, however, will still be present and can be used as a height indicator.

Figure 2. Locations and Functions of Optional Tractor Controls

OPERATING PROCEDURES

The remainder of this section contains tractor operating procedures. The procedures assume that the tractor is working properly. If the tractor fails to perform satisfactorily during operation, refer to the troubleshooting procedures in the Troubleshooting Section of this manual.

The procedures in this section have been arranged in the normal sequence of operations commencing with "Checks before Starting" through "Operating with Attachments." The arrangement of these procedures is intended primarily to acquaint you as the operator with the fundamental operating procedures to ensure the safe, efficient operation of your tractor. It is recommended that when operating the tractor for the first time that you make the following operational checks in sequence:

- Locations and Functions of Controls
- Checks Before Starting
- Stopping the Tractor
- Starting the Engine
- Starting Tractor into Motion
- Before Leaving the Tractor

Also, when driving the tractor for the first time, start off slowly and drive only on level ground. Get the feel of starting, stopping, and starting again. Then increase speed by moving transmission control lever and engine speed control.

After you have become familiar with all of the procedures for the tractor you should be ready to operate the attachments. Refer to the instructions in this section titled "Operating with Attachments," the attachment operation chart (figure 22), and the appropriate Operator's Manual for the attachment.

Checks Before Starting

Read this manual completely before the first use of your tractor, and thereafter as often as necessary to ensure safe and efficient tractor operation.

The following checks should be performed before starting the engine for the first time. Repeat these checks each time you use the tractor to ensure that it is ready for use.

1. Refer to Normal Care Section of this manual to determine and perform needed care. Be sure to check the engine crankcase oil level.
2. Check all nuts, bolts, screws, and pins to be sure they are in place and tight.

3. Seat yourself on the tractor. Try operating some of the controls to see if the seat position fits you. If not, see the seat adjustment procedure in the Adjustments Section of this manual.
4. Check the fuel gauge. If you need more fuel to complete the job at hand, fill the tank as follows:



WARNING

Gasoline is highly flammable and must be handled with care. Never fill the tank when the engine is hot. Do not allow open flame, smoking, or matches in the area. Avoid overfilling and wipe up any spills.

- a. Remove fuel gauge cap as shown in figure 3.
- b. Fill fuel tank with clean, fresh, lead-free regular grade gasoline. Leaded regular gasoline is acceptable, but Kohler recommends using lead-free.
- c. Install and hand tighten fuel gauge cap.

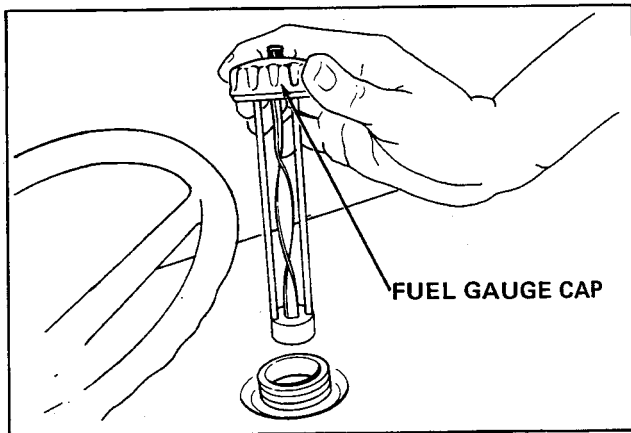

Figure 3. Fuel Gauge Cap

Stopping the Tractor

In most cases, the tractor can be stopped by simply returning the transmission control lever to the neutral notch position. The clutch-brake pedal can also be used to stop the tractor. For a gradual stop on level ground, press the pedal down only far enough to disengage the clutch. For a more rapid stop, press the pedal down further to also apply the brake.

Try to avoid sudden stops on hills. Also avoid using the brake to control downhill speed. Select a low transmission control lever setting and a slow engine speed before starting downhill.

Moving the Tractor without Engine Power

Normally, the hydrostatic transmission will not allow the tractor to be pushed. To push the tractor, it is necessary to push the free wheeling latch down (see figure 4). To again engage the transmission, the free wheeling latch must be pulled up and locked.

NOTE

Towing the tractor faster than a normal walking speed or for all but the shortest distances will cause transmission damage. To avoid this, never use another vehicle to push or pull your tractor.

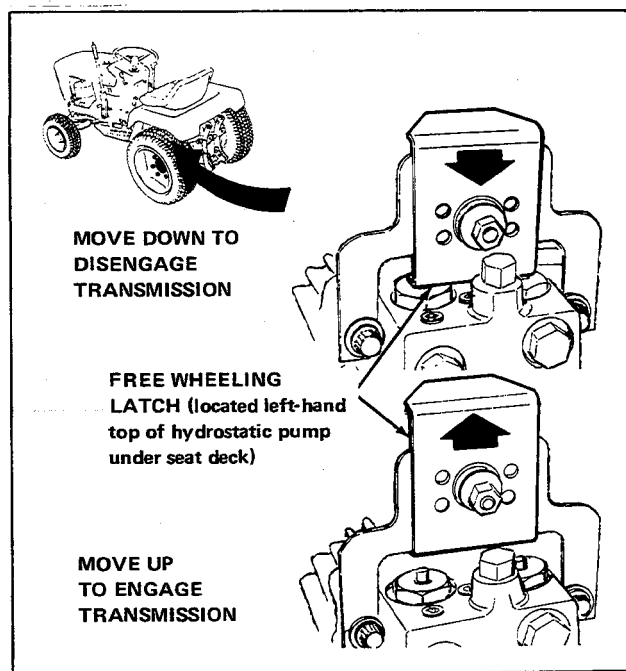

Figure 4. Free Wheeling Latch

Starting the Engine

After completing the "Checks Before Starting," proceed as follows:



WARNING

For your personal safety, do not start or run engine in an enclosed area. Exhaust fumes are deadly.

1. Seat yourself in the operator's position.
2. Set parking brake by lifting parking brake lever up and back until it rests against fender.
3. Pull choke control out fully (it may not be necessary to choke a warm engine).

4. Set the engine speed control in the idle position for starting, as recommended in your Kohler engine Owner's Manual.

NOTE

The transmission control lever must be in neutral and PTO lever in fully disengaged position before the engine will start.

5. Pull PTO clutch lever up and fully back to disengage PTO clutch.
6. Put transmission control lever in neutral notch position.
7. Press clutch-brake pedal down to disengage clutch. **Keep clutch disengaged until engine starts.**
8. Turn the ignition key to START. The electric starter should crank the engine. If not, repeat steps 5 and 6.
9. When the engine starts, release the key. It will return to the ON position for normal running.
10. Move engine speed control to SLOW position.
11. As engine warms up, push in choke control.
12. Warm up the engine for at least one minute before engaging PTO clutch or driving tractor.

Starting Tractor into Motion

This procedure describes how to safely start the tractor into motion after starting the engine.

1. Position the front wheels straight ahead. Whenever possible, the first motion should be straight forward or backward.
2. Set engine control for 1/3 to 1/2 speed.
3. Release parking brake.
4. Check that the path is clear in the direction you want to go.
5. Slowly release clutch-brake pedal to engage clutch.
6. Move transmission control lever from neutral notch position. Push it slowly forward to move forward or pull it slowly rearward to move in reverse.
7. Adjust transmission control lever and engine speed control for desired speed.

Operation on Slopes

For your personal safety, always operate your tractor up and down the face of slopes, and never across the face. Never attempt to operate on steep slopes. Be sure to use slow tractor ground speeds on slopes, and use extreme caution when changing direction on any slope. Do not start or stop suddenly on slopes.

Also, use tractor wheel weights where required or recommended for added stability and handling on slopes. See the "Operating with Attachments" chart (figure 22) at the end of this manual and your attachment Operator's Manual for wheel weight and slope information when operating with attachments.

Use two rear wheel weights when operating your tractor on slopes over 20 percent (11.3°). Never operate on slopes greater than 35 percent (19.3°), which is a 3-1/2 feet rise in 10 feet forward, and always operate in an up and down direction.

Operating with Attachments

These instructions describe a general procedure for tractor operation with attachments.

1. Be sure the attachment is properly installed and ready for use. Refer to attachment Operator's Manual.
2. Start tractor engine.
3. Raise the attachment.
4. Start tractor into motion and proceed to work site.
5. At work site, move transmission control lever to neutral notch to bring tractor to complete stop.
6. Unlock lift lever and lower attachment. To unlock lift lever, pull lever back slightly before pressing lock release pushbutton on top of lever.
7. Clear work site of any objects that might be thrown by or get caught in attachment.
8. Set engine speed control for 3/4 speed.
9. Be sure the attachment discharge is not directed toward people or pets.
10. If PTO is being used, push PTO clutch lever completely forward and down to engage attachment.

11. Adjust engine speed control to setting best suited to attachment operation. Refer to attachment operation chart (figure 22) and Attachment Operator's Manual.
12. Start tractor into motion.
13. Adjust transmission control lever to produce best tractor speed for operation of attachment.

NOTE

Complete remaining steps to return machine to storage.

14. Stop tractor motion by moving transmission control lever to neutral position, and then disengage PTO.
15. Raise attachment to its highest position.
16. Resume tractor motion to return to storage site.

Before Leaving Tractor

For your safety and that of others, perform steps below before leaving tractor seat.

1. Disengage PTO and stop tractor motion by moving transmission control lever to neutral notch.
2. Set engine control to SLOW.

NOTE

Stopping a hot engine too suddenly can cause engine damage. Move engine control to SLOW and idle engine for about one minute before stopping engine.

3. Set parking brake.
4. Lower attachment.
5. Turn ignition key to OFF and remove key.

Normal Care

CONTENT OF SECTION

Your tractor was designed and built to provide years of service with only minor care. Certain tasks, however, must be performed to keep the tractor in good operating condition and to avoid costly repairs. This section provides the necessary care instructions for your tractor. To service an attachment, refer to the separate manual for that attachment.

SCHEDULED CARE

A schedule for routine care is provided in figure 6. We suggest that you check the items to ensure that the tractor is ready for use. Performing these checks will also help you to become familiar with the care of the tractor.

All other scheduled care is performed after operating the tractor for a specific amount of time. See figures 6 through 11. Remember to perform the "every 25-hour check" when you perform the "every 100-hour check."

Because the schedule is based on operating time, it is necessary to determine the actual operating time. This is easily accomplished if your tractor has an optional hour meter. If not, you can determine normal times for regular jobs such as cutting your lawn. Multiply these normal times by the number of times you perform the jobs to estimate total operating time.

A Maintenance Record (figure 5) is provided on the preceding page to help you document all operating hours and maintenance repair actions.

NORMAL STORAGE

To protect your tractor, store it in an enclosed dry area. Do not store it in an enclosure where fumes from the fuel tank could reach an open flame without first running the fuel tank dry.

To store your tractor in a cold area between winter snow removal jobs, we suggest that you fill the fuel tank at the completion of each job to prevent water condensation in fuel tank. If you do not intend to use your tractor during the winter months, follow the off-season storage instructions given below.

OFF-SEASON STORAGE

When the tractor is to be stored for two months or longer, take precautions as follows:



WARNING

For your personal safety, keep open flame or spark away from flammable gasoline when working near the fuel tank. Never store tractor where gasoline fumes may reach an open flame or spark.

1. To empty or prepare fuel tank:
 - a. Run tractor engine until it stops from lack of fuel, or

Care Required	See	Schedule				
		Before First Use	Every 5 Hours	** Every 25 Hours	Every 100 Hours or Annually	*** Spring and Fall
Check Tractor and Engine	Page 14	•	•			
Clean Engine and Air Filter	Engine Manual			•		
Change Engine Oil*	Engine Manual			•		•
Lubricate Tractor	Figure 7	•		•		
Check Fluid Levels and Tires	Figure 8	•		•		
Check Transmission Fluid	Figure 9	•			•	
Clean Battery and Cables	Figure 10			•		
Clean or Replace Spark Plug	Engine Manual				•	
Repack Front Wheel Bearings	Figure 11				•	

*Change original engine oil after first 5 hours of operation.
 **More often in hot (over 70°F: 21 °C) weather or dusty operating conditions.
 ***Only if tractor is used in both summer (over 40°F) and winter (under 40°F: 4.5 °C)

Figure 6. Summary of Scheduled Care

- b. Use a gasoline stabilizer. This additive, available from your dealer, prevents formation of gum and varnish for up to one year. With the additive, fuel may remain in your tractor tank for long periods.
2. Change engine oil while the engine is still warm. See your Kohler engine Owner's Manual.
3. Remove spark plug. Pour one ounce (30 ml) of SAE-30 oil into engine through spark plug hole. Crank engine a few times to distribute oil and then reinstall the spark plug.
4. Lubricate tractor. (See figure 7).

**WARNING**

Batteries contain a sulfuric acid solution which can cause serious personal injury or property damage. Use care to prevent an accidental spill of the battery acid. Do not allow the battery fluid to contact eyes, skin, fabrics, or painted surfaces.

5. Check battery fluid level. (See figure 8). Battery life will be increased if it is removed and stored in a cool, dry place, fully charged.
6. At end of storage period, follow instructions in "Starting after Storage."

STARTING AFTER STORAGE

Before starting the tractor after a period of off-season storage, perform the following:

1. If it was removed, install battery. (See figure 10).
2. Remove spark plug and wipe dry. Crank engine a few times to blow excess oil out of plug hole. Then reinstall the plug.
3. Fill fuel tank with fresh gasoline (unless a fuel stabilizer was used).
4. Clean engine fins and air filter. See your Kohler engine Owner's Manual.
5. Check fluid levels and tire pressure. (See figures 8 and 9).
6. Start the engine outdoors. Do not run engine at high speeds immediately after starting.

CHECK TRACTOR AND ENGINE (5-Hour Care)

1. Check tractor and engine for loose bolts, nuts, screws, oil leaks, etc. Be sure any attachment safety guards or shields are in place and secure.
2. With the tractor level, check/add engine crankcase oil according to your Kohler engine Owner's Manual. Use the same grade and weight of oil used at last change. **Do not overfill.**

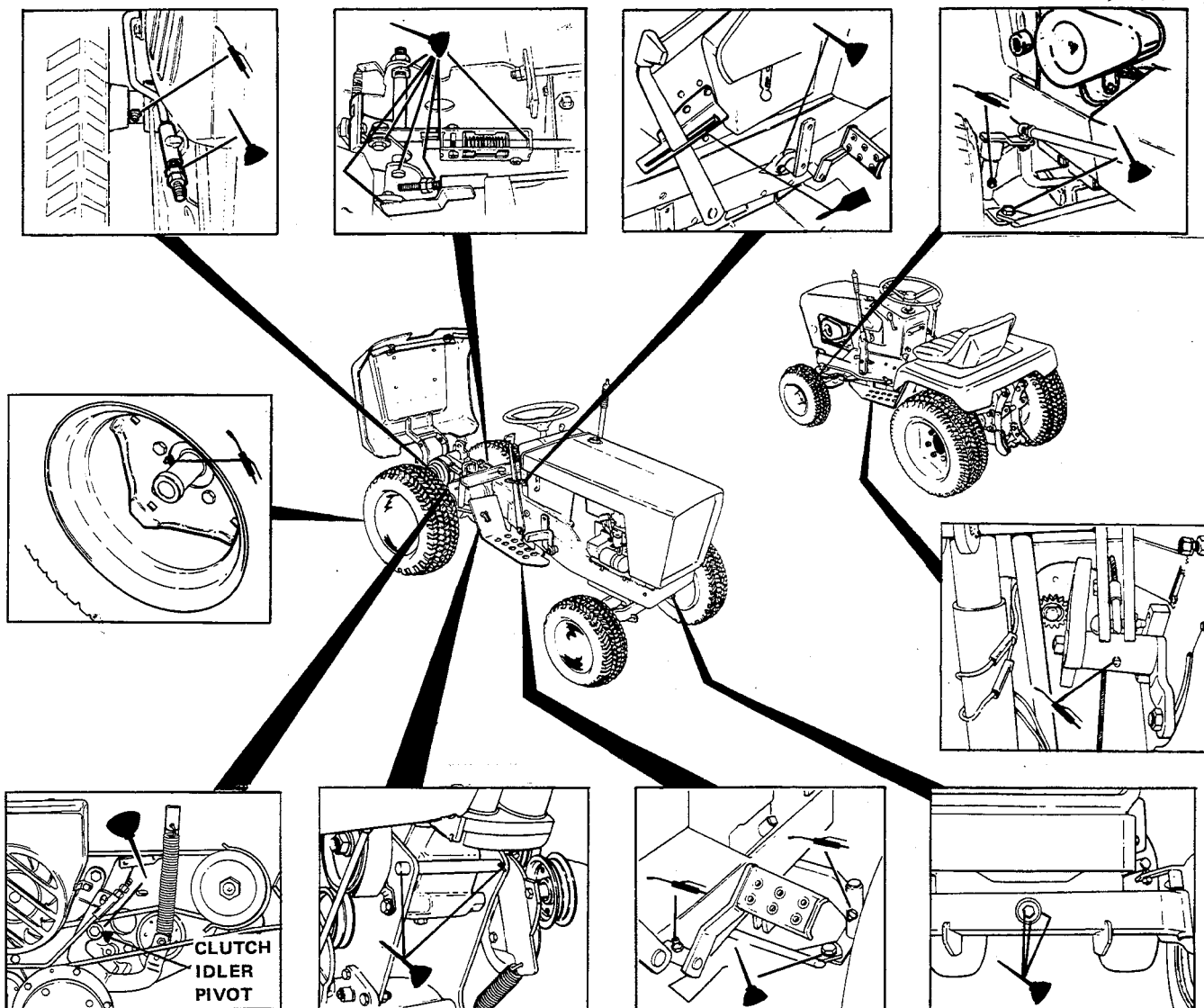

NOTE

Keep grease and oil off belts and pulleys.



Symbol	Use	Apply With	Procedure
	Lithium base automotive grease	Grease gun	<ol style="list-style-type: none"> 1. Wipe fitting clean with rag. 2. Apply 2 or 3 shots of grease. 3. Wipe up any excess grease.
	Medium weight (SAE 30) oil	Oil can	<ol style="list-style-type: none"> 1. Brush and wipe dirt and grass from area. 2. Apply a few drops of oil. 3. Wipe up any drips or spills.
	Lithium base automotive grease	Brush	<ol style="list-style-type: none"> 1. Wipe area clean of old grease and dirt. 2. Apply thin film of grease with hand or brush.

Figure 7. Lubricate Tractor (25-Hour Care)

NOTE

Wait at least 10 minutes after operation before checking bevel gear box oil level.

1. Check bevel gear box oil level.
 - A. Remove fill plug.
 - B. The oil level should touch the tip of the fill plug when the plug is loosely installed. If not, add Simplicity lubricant (part no. 1685092), available from your dealer, or an equivalent tractor hydraulic lubricant, to tip of fill plug when it is loosely installed.
 - C. Reinstall and tighten fill plug.

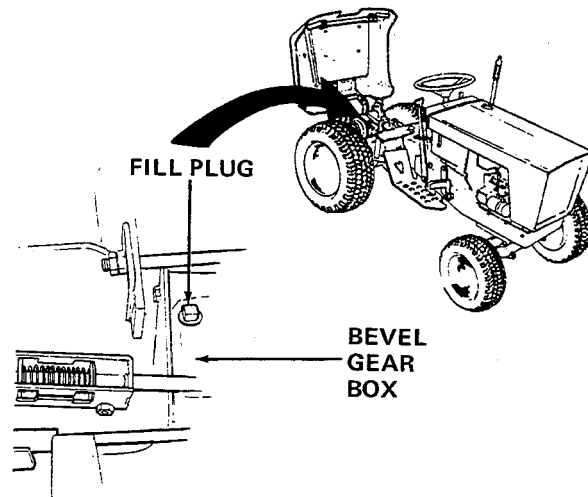

2. Check battery fluid level.
 - A. Remove filler caps, one at a time.
 - B. Fluid must be even with split ring full mark. If not, add distilled water.
 - C. Reinstall filler caps.
3. Check air pressure of all four tires (pressures apply for both Turf and Agricultural type tires).

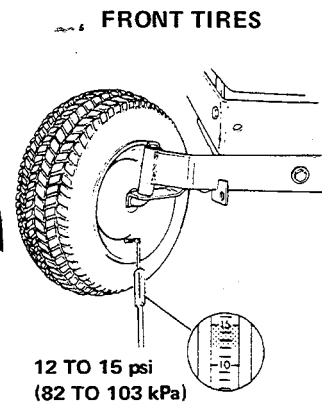
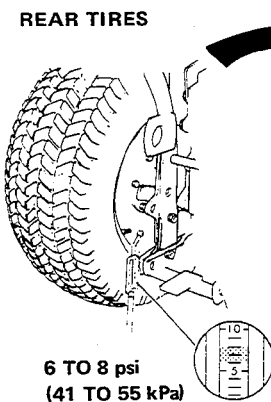
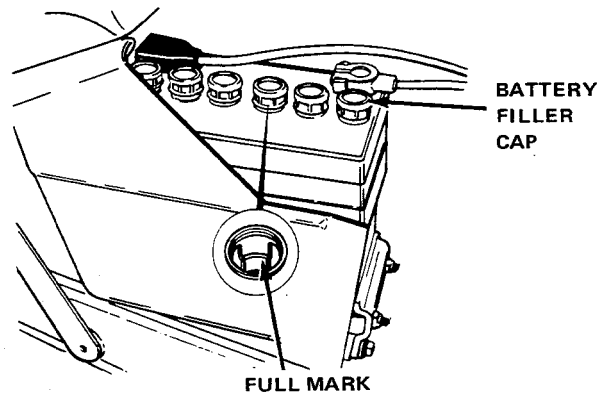
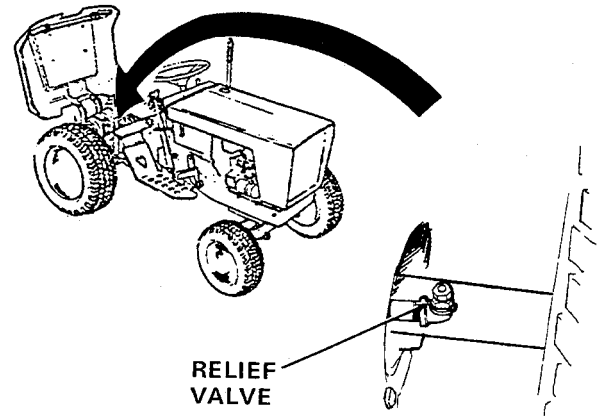

Figure 8. Check Fluid Levels and Tire Pressures (25-Hour Care)

NOTE

Check fluid when transmission is cold.

1. Wipe the transmission filler cap and filler pipe clean.
2. Remove transmission filler cap.
3. Lift and hold relief valve open.
4. Fluid should be at top of filler pipe. If it is not, add Dexron II or Type F automatic transmission fluid to top of pipe.
5. Release relief valve.
6. Reinstall and secure filler cap.



NOTE

A transmission fluid filter is visible from the bottom of the tractor. Replace this filter every 400 hours of operation or whenever changing transmission fluid. The replacement filter must have a 25 micron rating and be a full flow type without anti-drain back. (available from your dealer). Transmission fluid should be changed only when performing repair work on transmission or hydrostatic unit, or if it becomes discolored (dark brown or black) from overheating. Be especially careful when changing the filter fluid that no dirt or other contaminant is allowed to enter the system.

When replacing the filter, fill it with fluid before installing it. Then wet the gasket with fluid and handtighten the filter in place. Finish adding

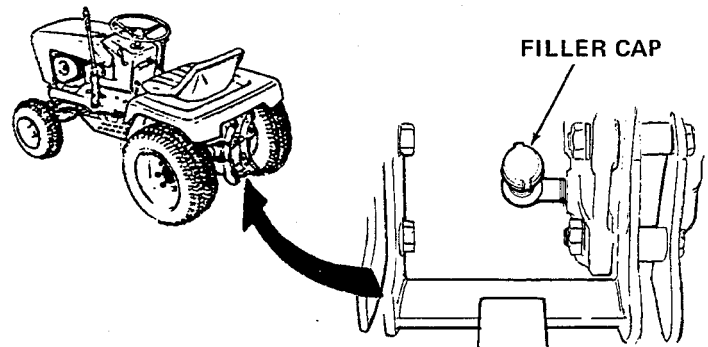

fluid through the fill pipe as instructed above. Capacity: about 3 quarts (2.8 L). Check for leaks.



To be sure transmission is full, start the engine and then stop it again. Wait one minute. Then check the fluid level following the normal checking procedure above. Repeat this check and add fluid as needed until the level remains at the top of the filler pipe. Recheck for leaks.

Figure 9. Check Transmission Fluid (100-Hour Care)

 **CAUTION**

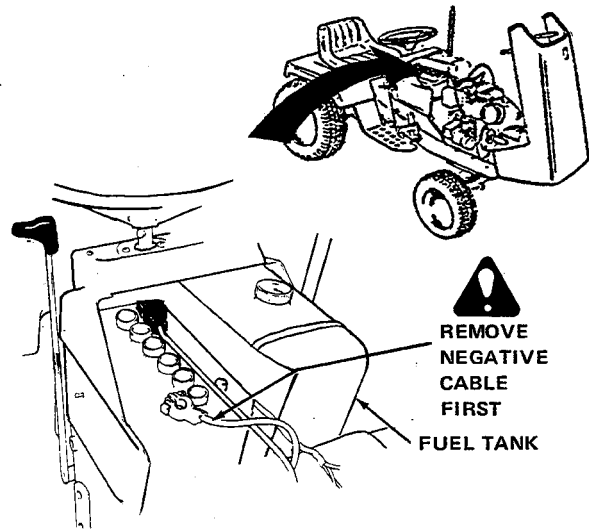
For your personal safety when removing battery cables, always disconnect the negative cable **FIRST** and reconnect it **LAST**. The positive battery terminal can be easily shorted to the tractor frame by a wrench or other tool if this is not done.



-  1. Remove cables, negative cable first. Lift and slide back the clamp cover to remove the positive cable.
2. Loosen battery clamp.
3. Remove battery.
4. Scrub battery, cables, and battery compartment. Use baking soda and water.
5. Clean terminals and cable clamps with wire brush.
6. Install battery and tighten battery clamp.
-  7. Install the positive cable and slide the clamp cover back in place.
8. Install the negative cable.
9. Coat cable clamps and terminals with grease or petroluem jelly.

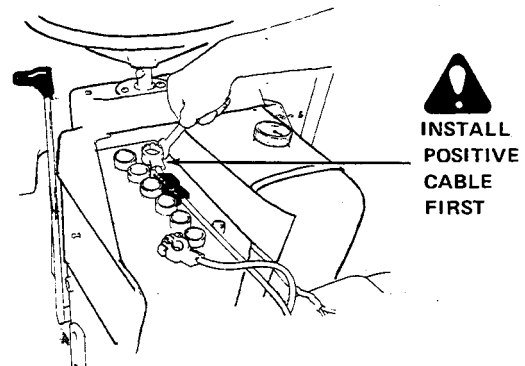
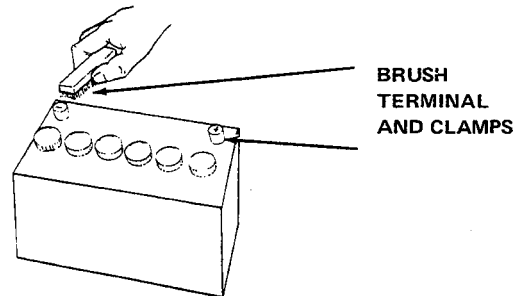

Figure 10. Clean Battery and Cables (25-Hour Care)



WARNING

For your personal safety, block the rear wheels when raising the tractor front end. Never trust the jack alone; use jack stands or blocks in addition to the jack. Do not raise the tractor higher than need be, and do not put arms or legs under tractor.

1. Block or jack up front of tractor for wheel removal
2. Pry off grease cup with a screwdriver or a claw hammer.
3. Loosen collar setscrew using an Allen wrench.
4. Remove collar, washer and outer bearing.

NOTE

Keep the two bearings separate. Each should be reinstalled in its original place.

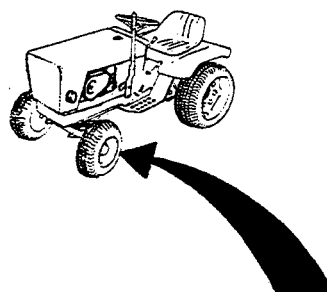

5. Remove wheel and inner bearing.
6. Wash wheel shaft, bearings, and internal part of wheel with solvent to remove all old grease. Wipe dry.
7. Inspect seal. If seal is damaged, replace it.

NOTE

Use only a prime quality wheel bearing grease. Keep grease free of dirt.

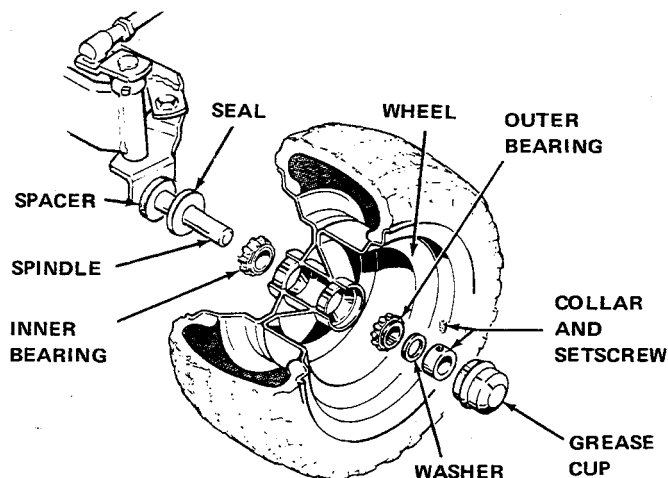

8. Coat seal and spindle with grease.
9. Lubricate bearings completely with grease. Use hand to force grease in the spaces between bearing rollers.
10. Install inner bearing and wheel on axle.
11. Install outer bearing, washer and collar.
12. Press collar towards tractor and spin wheel slowly to seat bearings.

13. When wheel and bearings are seated and against seal, hold collar and tighten setscrew securely.
14. Test seating by attempting to wobble wheel. If wobble is more than just evident, loosen setscrew and repeat steps 13 and 14.
15. Replace grease cup and wipe up any excess grease.
16. Repeat entire procedure for other wheel.

Figure 11. Repack Front Wheel Bearings (100-Hour Care)

NOTES

Troubleshooting

CONTENT OF SECTION

This section of the manual provides troubleshooting and repair instructions for the more common and easily corrected problems. For other problems, it is recommended that you contact your dealer.



WARNING

To avoid serious injury, perform maintenance on the tractor only when the engine is stopped, and the parking brake engaged. Always remove the ignition key before beginning the maintenance to prevent accidental starting of the engine.

TROUBLESHOOTING PROCEDURES

Troubleshooting procedures are provided in figure 12. To use these procedures, first locate the problem description that best describes the trouble that you have encountered. Check the possible causes one at a time in the order that they are listed. Correct any problems that are found and operate the tractor again to be sure you have eliminated the trouble.

Problem	Cause/Remedy
1. Starter motor does not crank.	<ul style="list-style-type: none"> A. Transmission control lever not in neutral position. Shift into neutral. B. PTO clutch lever(s) not disengaged. Disengage fully. C. Circuit breaker tripped. Wait one minute for automatic reset. Replace if defective(see your dealer). D. Wiring loose or broken. Visually check wiring and replace broken or frayed wires. Tighten any loose connections. E. Battery terminals are corroded. Clean according to Normal Care instructions (figure 10) F. Battery discharged or dead. Charge or replace as necessary. G. Starter or solenoid defective. Repair or replace.
2. Starter cranks, but engine will not start. (First check proper starting procedure for your engine on page 9).	<ul style="list-style-type: none"> A. Out of fuel. Refill fuel tank. B. Engine flooded. Push in choke and attempt to start. C. Crankcase oil too heavy. If so, change oil as specified in your Kohler engine Owner's Manual. D. Spark plug faulty, fouled, or incorrectly gapped. Clean and gap or replace. E. Water in fuel. Drain and refill with fresh fuel. F. Old stale gas. Drain fuel and replace with fresh fuel. G. Points worn or out of adjustment. See your Kohler engine Owner's Manual.
3. Engine starts hard or runs poorly.	<ul style="list-style-type: none"> A. Fuel mixture too rich. Push in choke all the way. Clean air filter. B. Carburetor adjusted incorrectly. See your engine manual. C. Spark plug or points faulty, fouled, or incorrectly gapped. See your Kohler engine Owner's Manual. D. Water in fuel. Tank and lines must be drained and dried.

Figure 12. Troubleshooting Procedures

Problem	Cause/Remedy
4. Engine knocks.	A. Oil level low. Check/add oil as required. B. Using wrong grade of oil. See your Kohler engine Owner's Manual.
5. Excessive oil consumption.	A. Engine running too hot. Clean engine fins and blower screen. B. Using wrong weight of oil. See your engine manual. C. Too much oil in crankcase. Drain excess oil.
6. Engine exhaust is black or smoky.	A. Dirty air filter. Clean air filter. B. Choke not fully open. Push in choke completely and be sure it opens fully. Check carburetor adjustment.
7. Tractor creeps forward or backward with transmission control in neutral notch position.	A. Transmission neutral setting requires adjustment. See Adjustment Section of this manual.
8. Engine runs, but tractor will not drive or lacks power.	A. Free wheeling latch pushed down. Pull latch up. B. Parking brake is engaged. Release. C. Transmission oil cold. Allow 3 minutes for warmup. D. Transmission fluid low. See figure 9. E. Drive belt slipping. See Adjustment Section. F. Kinked hydrostatic hoses. Check and correct as necessary. G. Transmission filter leaking. Check and tighten as necessary. H. Clutch idler pivot sticking. Lubricate (see figure 7).
9. Drive belt slips	A. Clutch free-travel or belt tension is incorrectly adjusted. See Adjustment Section. B. Pulleys or belt greasy or oily. Clean as required. C. Clutch rod binding in guide. Oil clutch rod. D. Belt stretched or worn. Replace with correct belt.
10. Brake will not hold.	A. Brake(foot pedal or parking)is incorrectly adjusted. See Adjustment Section. B. Brake lining is worn and requires replacement. (See your dealer).
11. Tractor handles poorly.	A. Improper tire inflation. Check and correct (see figure 8). B. Wheels are spinning or slipping. Use weights to provide additional stability and traction. C. Moving too fast on slopes. Reduce speed.

Figure 12. Troubleshooting Procedures (Cont'd)

Battery Replacement

A dead battery or one too weak to start the engine may not mean the battery needs to be replaced. It may, as an example, mean that the alternator is not charging the battery properly. If there is any doubt about the cause of the problem, see your dealer. If you need to replace the battery, proceed as shown in the battery cleaning procedure (figure 10).

Jump Start With Auxiliary (Booster) Battery

Jump starting is not recommended. However, if it must be done, follow these directions. Both booster and discharged batteries should be treated carefully when using jumper cables. Follow exactly the procedure outlined below, being careful not to cause sparks.



WARNING

For your personal safety use extreme care when jump starting. Never expose battery to open flame or electric spark — battery action generates hydrogen gas which is flammable and explosive. Do not allow battery acid to contact skin, eyes, fabrics, or painted surfaces. Batteries contain a sulfuric acid solution which can cause serious personal injury or property damage. Also note the close proximity of battery and gas tank.

1. Set parking brake and place transmission in "NEUTRAL". Turn off lights and other electrical loads.
2. Remove vent caps from both the booster and the discharged batteries. Lay a cloth over the open vent wells of each battery. These two actions help reduce the explosion hazard always present in either battery when connecting a "live" battery to a "dead" battery.

3. Attach one end of one jumper cable to the positive terminal of the booster battery (identified by a red color, "+" or "P" on the battery case, post or clamp) and the other end of same cable to positive terminal of discharged battery. DO NOT permit vehicles to touch each other, as this could establish a ground connection.
4. Attach one end of the remaining cable to the negative terminal (black color, "-" or "N") of the booster battery, and the other end to a bare metal surface on the frame of your tractor AWAY FROM the battery compartment (do not connect directly to negative post of dead battery). Take care that clamps from one cable do not inadvertently touch the clamps on the other cable. Do not lean over the battery when making this connection.
5. The tractor with the dead battery should now start.

Reverse the jump starting procedure exactly to remove the jumper cables. Then reinstall the vent caps and throw the cloths away as they may have corrosive acid on them.



WARNING

Any procedure other than the above could result in: (1) personal injury caused by electrolyte squirting out the battery vents, (2) personal injury or property damage due to battery explosion, (3) damage to the charging system of the booster vehicle or of the immobilized vehicle.

Do not attempt to jump start a vehicle having a frozen battery because the battery may rupture or explode. If a frozen battery is suspected, examine all fill vents on the battery. If ice can be seen or if the electrolyte fluid cannot be seen, do not attempt to start with jumper cables as long as the battery remains frozen.

Drive Belt Replacement

If the hydrostatic drive belt (item A, figure 13) becomes worn or breaks, replace it as follows:



WARNING

For your personal safety, stop tractor engine and remove the ignition key to prevent accidental starting of the engine.

1. Tie the clutch-brake pedal down in the disengaged position.
2. Raise the tractor seat deck.
3. Remove the capscrew (item C, figure 13) and remove the belt guard assembly (item B).
4. Remove the two capscrews (item D) and the thread forming screw (item E) to remove the fan guard assembly.
5. Remove the old belt and install the new one. Make sure the belt is in all pulley grooves and is not twisted.
6. Reinstall the fan guard with the capscrews (items D) and the thread forming screw (item E).
7. Release the clutch-brake pedal and check to be sure belt is still seated in all pulleys.
8. Reinstall the belt guard (item B) so the bracket on the back side almost touches the pulley hub. Hold the guard in place and tighten the capscrew (item B).
9. Check and adjust the drive belt according to the Clutch Free Travel instructions in the Adjustment Section.
10. Lower and latch the seat deck when finished.

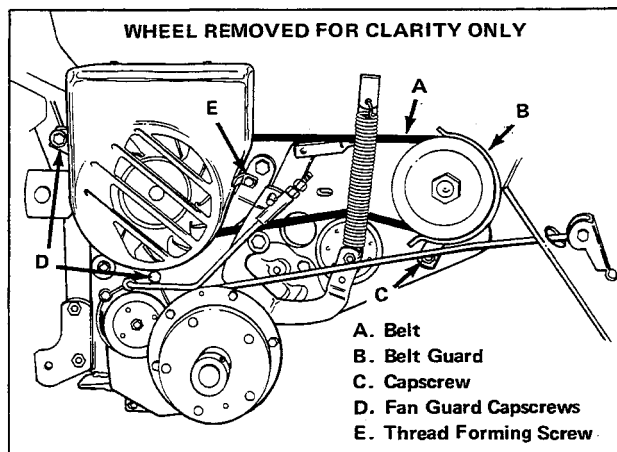

Figure 13. Replacing Drive Belt

Adjustments

CONTENT OF SECTION

This section contains adjustment procedures for the tractor and engine. The adjustments are normally performed only to correct specific problems. Because of the need for access to perform the adjustments, procedures for raising the seat deck and hood are also included in this section.



WARNING

To avoid serious injury, perform adjustment procedures on the tractor only when the engine is off and the parking brake set. Always remove the ignition key before beginning the adjustment procedures to prevent accidental starting of the engine.

Raising the Hood

The hood may be raised to the position shown in figure 14. With the hood raised, parts in the engine area are easily reached. Raise the hood as follows:



CAUTION

For your personal safety, be aware of the hot muffler and engine. Allow all parts to cool before working in the area.

1. Pull the rubber straps (figure 14) down and away from the holddown pins.
2. Raise the hood to the position shown in figure 14.
3. When your tasks in the engine area are completed, lower the hood to its normal position. Then pull the rubber straps over the holddown pins to lock the hood in place.

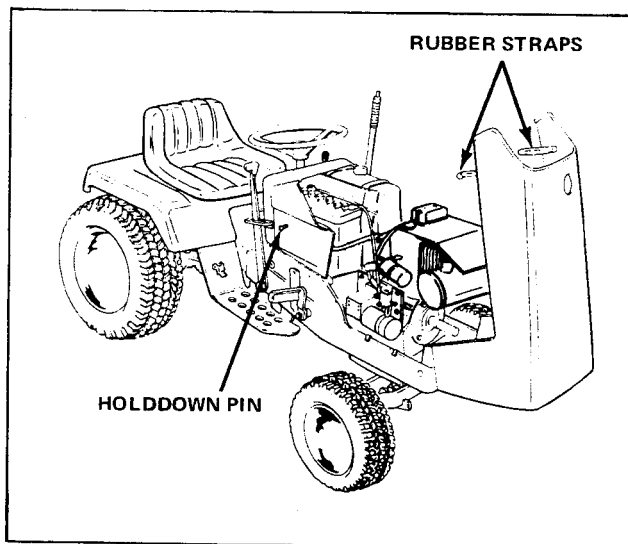

Figure 14. Raising Tractor Hood

Raising the Seat Deck

The seat deck may be raised to the position shown in figure 15. This will expose many of the transmission and clutch-brake adjustment points. To raise the seat deck, proceed as follows:



WARNING

Be sure engine is off before raising seat deck.

1. Reach under the seat deck and locate the locking levers (figure 15).
2. Press upward at the tips of both locking levers and raise the seat to the upright position.
3. When you have completed your tasks, push the seat deck down again until it locks in place.

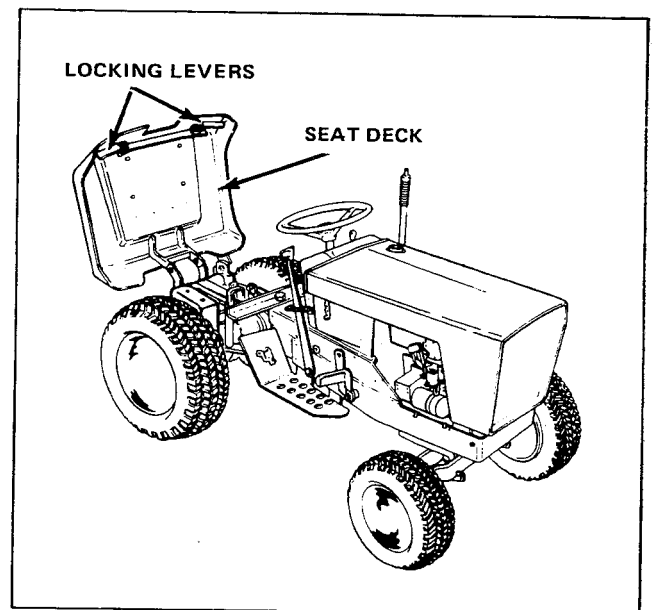

Figure 15. Raising the Seat Deck

ADJUSTMENT PROCEDURES

Seat Adjustment

The seat may be moved forward or backward to any of four different positions to suit different sized operators. To move the seat, proceed as follows:

1. Raise the seat deck.
2. Remove the two capscrews and lockwashers (item A, figure 16).
3. Remove the two nuts and lockwashers (item B).

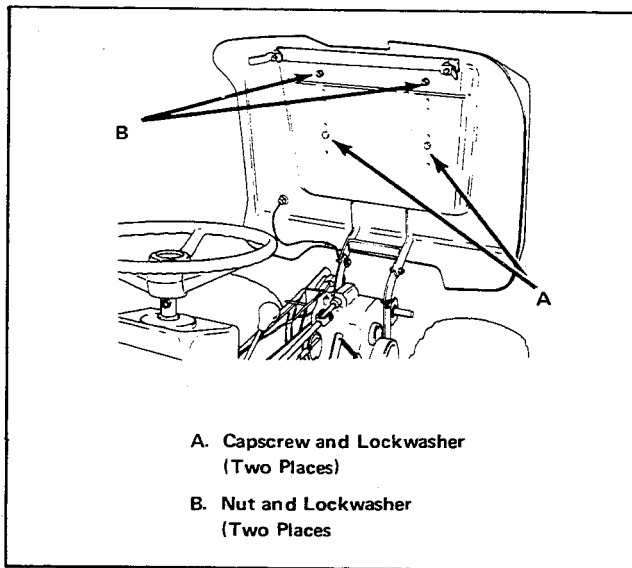

Figure 16. Seat Adjustment

NOTE

The rubber seat connectors (2) are used as spacers between the seat and seat deck when using the two front sets of mounting holes. When using one of the two rear sets of mounting holes, unscrew the connectors and install them from under the seat deck into the seat. In this way the rubber cushions will be under the seat deck. The hardware not used can be stored on the connector studs.

4. Move the seat to the desired set of mounting holes.
5. Install and tighten the lockwashers and nuts (item B).
6. Install and tighten the lockwashers and cap screws (item A).
7. Lower and lock the seat deck in place.

Clutch Free Travel

If the main drive belt does not engage or disengage properly, the clutch free travel may be incorrectly adjusted. To check the clutch free travel, raise the seat deck. Then pull the clutch-brake pedal fully up and back and measure the gap between the nut (item D, figure 17) and the rod guide (item C). If this gap is not 3/8 inch (9.5 mm), adjust the clutch-brake travel as follows:

1. Loosen the two nuts (items D and E, figure 17).
2. While holding the clutch-brake pedal fully up and back, turn the adjusting nut (item D) until the gap between it and the rod guide (item C) is 3/8 inch (9.5 mm).
3. Hold the adjusting nut (item D) at the correct measurement and tighten the locking nut (item E) to it.
4. Close the seat deck.

Transmission Neutral Adjustment

When the transmission control lever is in its neutral notch, the tractor should not creep forward or backward. If it does, adjust the transmission as follows:

1. Stop the tractor engine and place the transmission control lever in its neutral notch.
2. Raise the seat deck.
3. Check roller (item G, figure 17). The roller should be centered on the neutral mark of the cam (item H). If it is, proceed directly to step 7. If it is not centered, continue to step 4.
4. Loosen, but do not remove, nut (item F).
5. Adjust cam (item H) to center neutral mark on roller. Then hold cam while retightening nut (item F).
6. Lower seat and start engine. If tractor does not creep, omit remainder of this procedure. If creep is still present, continue on to step 7.
7. Stop the engine and remove the key. Block up the tractor so both rear wheels are free of the ground.



WARNING

For your personal safety, keep hands, clothing, and hair away from moving parts. Belts, pulleys, and rear wheels will be in motion during the remainder of the adjustment.

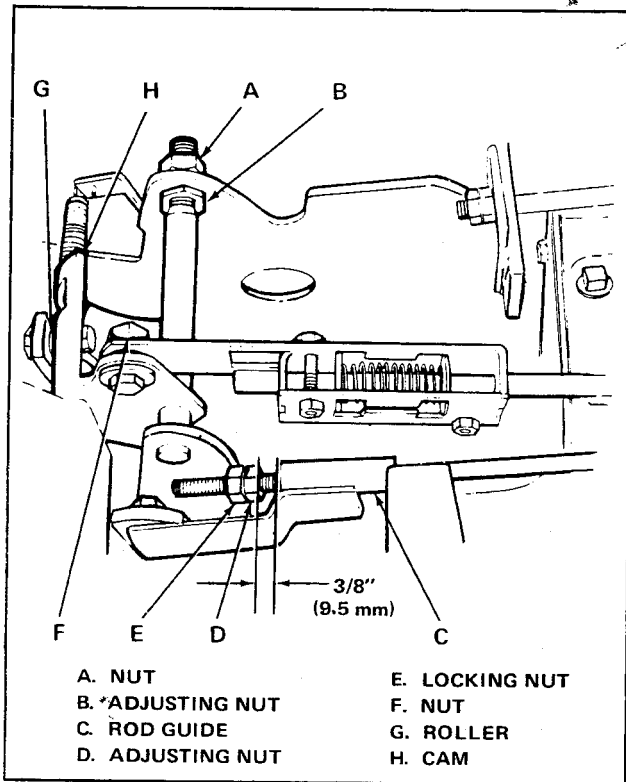

Figure 17. Clutch Free Travel and Transmission Neutral Adjustments

8. Start tractor.
9. Raise seat deck.
10. Loosen nut (item A, figure 17).
11. Turn adjusting nut (item B) in direction opposite wheel movement until creep stops.
12. Hold adjusting nut steady and tighten nut (item A) to secure adjustment.
13. Stop the engine, close the seat deck, and lower the tractor.

Parking Brake Adjustment

The parking brake should prevent the tractor from rolling when the engine is stopped. Adjust the parking brake as follows:

1. Loosen the jam nut (item A, figure 18).
2. With the tractor on a level surface and the wheels blocked to prevent tractor movement, release the parking brake by pushing the handle (item B) down.
3. Rotate the parking brake handle one complete turn in a clockwise direction to tighten the brake.

4. Check the adjustment by setting the brake. If it is difficult to set it is too tight. If it is too loose, return to step 2.
5. When proper adjustment is obtained, tighten the jam nut.

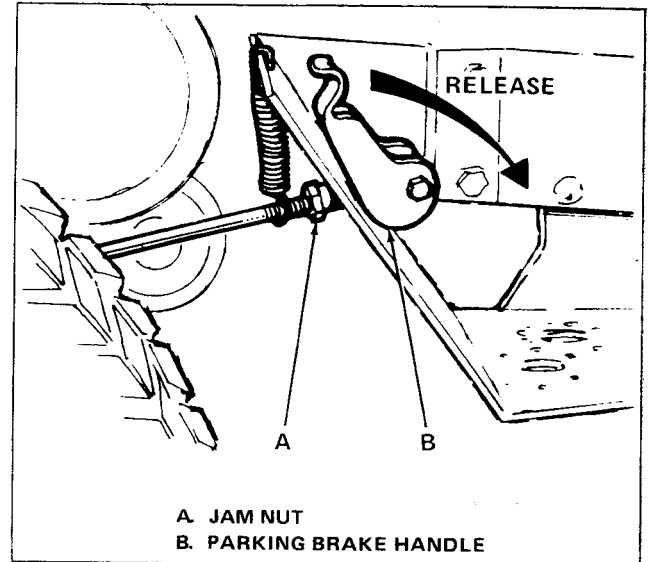

Figure 18. Parking Brake Adjustment

Foot Pedal Adjustment

The foot pedal brake may require adjustment if depressing it fully fails to stop the tractor. Perform this adjustment as follows:

1. Adjust the parking brake if you have not already done so.
2. Set the parking brake and open the seat deck.
3. Loosen the two nuts (items B and C, figure 19).
4. Turn the adjusting nut (item C) until the gap between it and the rod guide (item D) is 1/2 inch (13 mm).
5. Hold the adjusting nut (item C) still and tighten the locking nut (item B) to it.
6. Depress the clutch-brake pedal until the adjusting nut (item C) just touches the rod guide (item D). The drive belt (item A) should now be slack and free of the idler pulley. If not, check the clutch free travel adjustment.
7. Close the seat deck.
8. Start the tractor and test operate the brake. If the brake still does not stop the tractor, return to step 2 and repeat the adjustment procedures to reduce the gap in step 4 by 1/8 inch (3 mm).

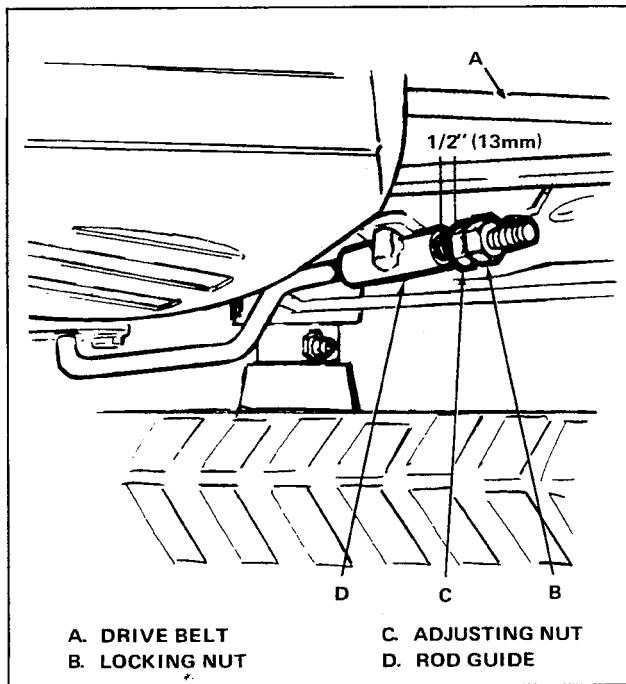

Figure 19. Foot Pedal Parking Brake

PTO Clutch Adjustment (All Models)

To check the PTO Clutch Adjustment, raise the seat deck. Then observe the movement of the pulleys (item C, figure 20) in relation to the clutch plate (item D) as the PTO clutch lever is moved from the engaged to the disengaged position. The pulley movement should be 3/64" (1.2 mm). If not, adjust the PTO clutch as follows:

1. Set PTO clutch lever to engaged position.
2. Loosen the locking nut (item B).
3. Turn the adjusting nut (item A) slightly clockwise to increase pulley travel or slightly counterclockwise to decrease pulley travel.
4. Hold the adjusting nut still and tighten the locking nut to it. Repeat the check and re-adjust if necessary.
5. Close the seat deck.

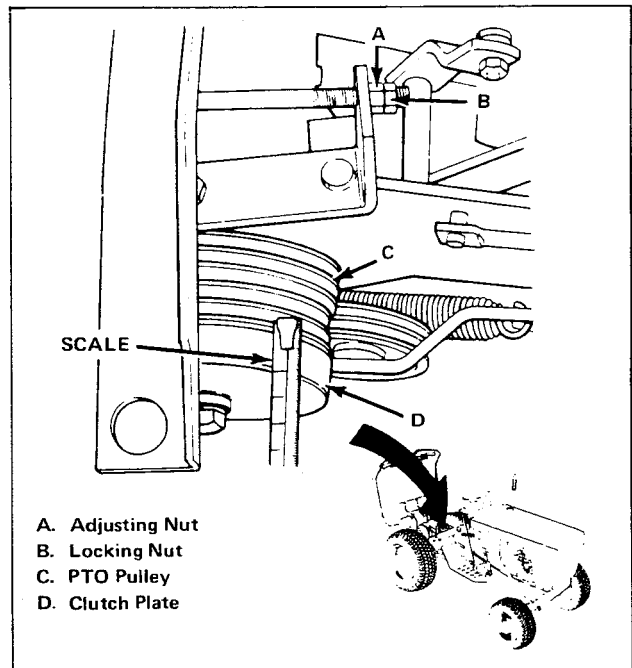

Figure 20. PTO Clutch Adjustment

Assembly

CONTENT OF SECTION

This section provides the necessary instructions for assembling the tractor and preparing it for operation. Your dealer has performed the necessary setup procedures, but they still can be rechecked by you. This will help familiarize you with the tractor.

TO UNCRATE: Remove the top, side, and end sections of the crate and then the plastic covering from the unit. Remove the bands holding the tractor at the front and rear axles. Then remove the Instruction Packet and set it aside.

TRACTOR SETUP

Cut the banding material to remove the steering wheel from the footrest. Then remove the capscrew and flange locknut from the steering shaft. The three flat washers on the steering shaft should be used as necessary to fill the gap under the steering wheel. Check fit the steering wheel to see how many washers are needed, and then install the steering wheel with the capscrew and flange locknut. Roll tractor off the rear of the pallet, being careful to avoid nails and staples.



CAUTION

For your personal safety, the battery should be removed from the tractor for activation.

Remove the battery from the tractor and fill it with electrolyte to the split rings in each cell. **DO NOT OVERFILL.** Let the electrolyte stand for 20 minutes and recheck the level, topping up if necessary. Charge the battery until there is a specific gravity of 1.260 in each cell. Reinstall the battery and connect the cables, **NEGATIVE CABLE LAST.**

The tires are overinflated for shipping purposes. Release air from the tires until pressures are 6 to 8 PSI (41 to 55 kPa) in the rear tires, and 12 to 15 PSI (82 to 103 kPa) in the front tires. Any tires below these pressures when received should be checked for leaks.

With the tractor level, fill the crankcase with oil according to the Kohler engine Owner's Manual. Check oil level during procedure so as not to overfill. The crankcase capacity is about 2 quarts (1.9 L).

Check the transmission fluid level according to the Normal Care section of this manual.

Check the bevel gear box oil level according to the Normal Care section.

Check tractor lubrication according to the Normal Care section. Pay special attention to wheels and to clutch-brake, drive, and steering linkages.

Fill the fuel tank with clean, fresh, lead-free regular grade gasoline. (Leaded gasoline is acceptable substitute.)

Check for oil and gasoline leaks.

Check all capscrews, nuts, pins, etc. for tightness. Pay particular attention to the engine mounting bolts and the hardware securing the lower steering assembly.

Start the engine and test all controls for proper operation and adjustment. Be sure to test the transmission and PTO safety switches. The engine should not start with either the transmission or the PTO, or both, engaged. After stopping the engine, recheck for oil and gasoline leaks.

If all controls operate properly during testing, then proceed directly to the **FINAL SETUP CHECKS.**

If any control fails to operate properly during testing or seems to be out of adjustment, check and readjust it according to the Adjustment section of this manual. Be sure to follow all adjustment procedures in the order given, and be especially sure that an adjustment you make does not affect another adjustment area. Test operate the tractor again, checking all controls. When all problems are corrected, proceed to the **FINAL SETUP CHECKS.**

FINAL SETUP CHECKS

Recheck the hardware in any area where you have made an adjustment to be sure it is in place and tight.

Check to be sure all decals are undamaged and that there are no scratches or mars in painted surfaces. Touch up paint as needed.

Keep the product literature with the tractor to help avoid losing it.

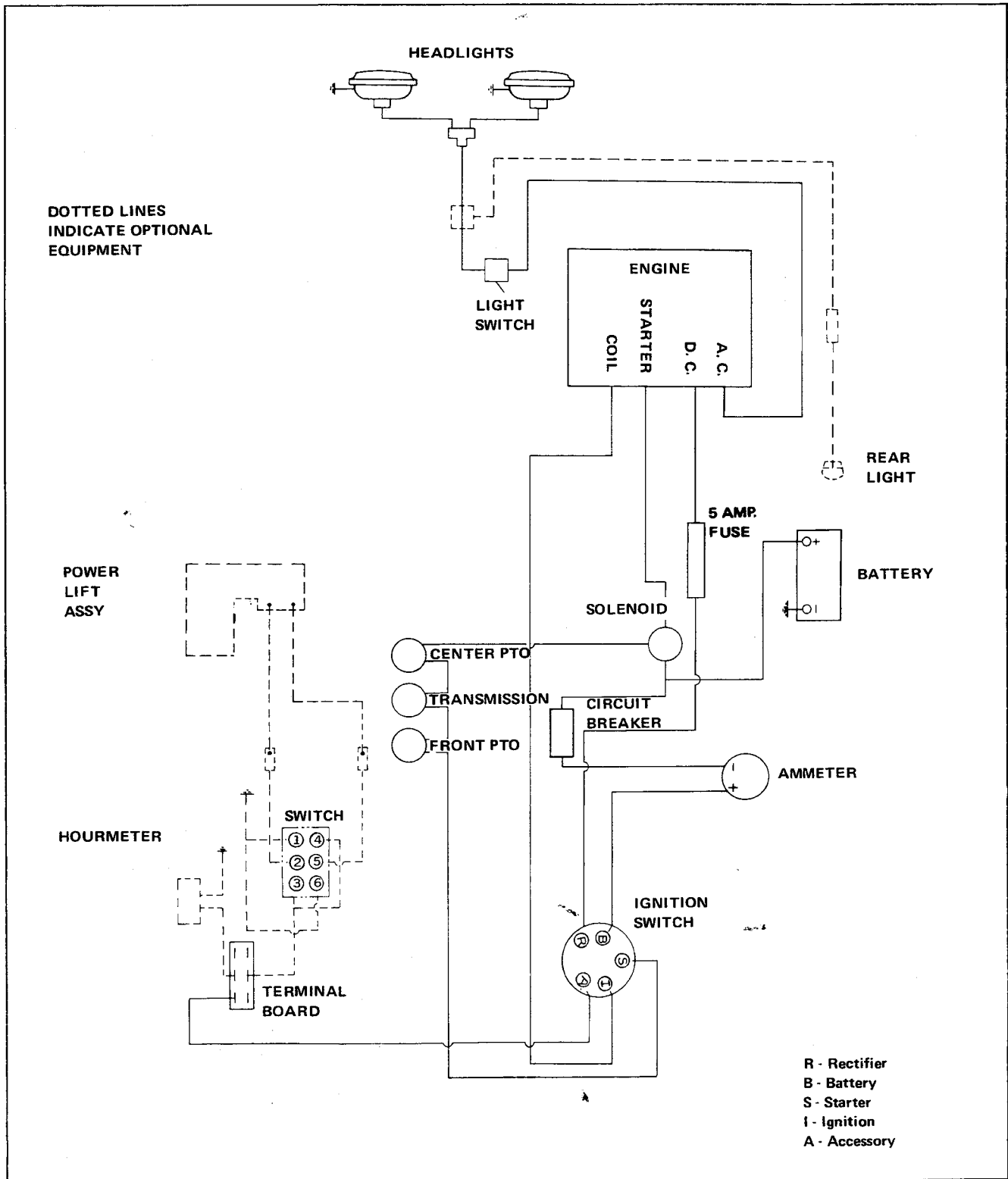

Figure 21. 7018H Electrical Schematic

Specifications

ENGINE	7018H	MAKE: Kohler MODEL NO: K361 HORSEPOWER: 18(13.4 kW) CYCLES: 4 CYLINDERS: 1	BORE: 3-3/4 Inches (95.3 mm) STROKE: 3-1/4 Inches (82.6 mm) DISPLACEMENT: 35.89 Cu. In. (588.1 cc) CRANKSHAFT: Horizontal
	Electrical System	Split-Circuit Alternator	
		12 Volt — 45 Ampere Hour Battery	
		Key Ignition Switch	
		Ammeter on Instrument Panel	
	Ignition	TYPE: Battery Ignition w/Breaker Point	
		Dust Proof Breaker Enclosure	
	Governor	TYPE: Internal Fly-Weight with External Adjustment	
		RANGE: 3700 R.P.M. No Load	
	Air Cleaner	TYPE: Replaceable Dry Paper	
	Crankcase	BREATHER: Ventilated through Carburetor	
		LUBRICATION: Gear Impeller System	
OIL CAPACITY: 2 Quarts (1.9 L)			
Fuel Tank	MATERIAL: Non-Corrosive, Molded Synthetic Material		
	Fuel Level Gauge Built into Filler Cap		
	CAPACITY: 3 Gallons (11.4 L)		
Muffler	Quiet Compact, Low Back Pressure		
TRANSMISSION	Type	Hydrostatic Pump and Motor	
		Air Cooled by Own Fan	
	Pump	Variable Displacement Axial Type	
	Motor	Fixed Displacement Reversible Axial Type	
	Hydraulic Fluid	TYPE: Type F Automotive Transmission Fluid or Dexron II	
		RESERVOIR: Final Drive Gear Case, 3 Quart (2.8 L) Capacity	
		FILTER: Cartridge w/25 Micron Rating, full flow w/o anti-drain back.	
	Control	Spring Dampened Single Lever	
		Neutral Detent with Safety Start Switch	
		Free Wheeling Valve and Latch for Manual Tractor Movement	
	Speed Range at 3600 R.P.M. Engine Speed	Continuously Variable, Forward or Reverse, without Clutching or Shifting	
		FORWARD: 0 to 7 MPH (0 to 11.3 km/h)	
REVERSE: 0 to 4 MPH (0 to 6.4 km/h)			
Final Drive	Hardened Spur Gears		
	Rolling Contact Bearings		
Differential	All Gear, Controlled Traction Type		

CHASSIS	Frame	Channel, Electrically Welded, Heavy Gauge Steel	
		POWER TAKE-OFF POINTS: Front, Center, Rear	
		ENGINE MOUNTING: Above Front Axle	
		PIVOT POINT LOCATION: At Front Axle	
	Rear Wheels	PNEUMATIC INFLATION PRESSURE: 6 to 8 psi (41 to 55 kPa)	
		TIRE SIZE: 23 - 10.50 x 12 Turf Type (Option)	
		TIRE SIZE: 23 - 10.50 x 12 Agricultural Type (Option)	
	Front Wheels	PNEUMATIC INFLATION PRESSURE: 12 to 15 psi (82 to 103 kPa)	
		TIRE SIZE: 16 x 6.50-8	
	Accessibility	Hood Tips Forward. Seat Deck Tips Rearward.	
Seat	TYPE: Molded — Foam. COVER: Black Vinyl. POSITIONS: 4		
Turning Radius	INSIDE REAR TIRE: 30.5 Inches (775 mm)		
CONTROLS	Steering	Full Circle Steering Wheel	
		SYSTEM: 4.14-to-1 Ratio, Gear and Sector	
	Clutch-Brake Pedal	LOCATION: Right Front	
		CLUTCH: Soft Action, V-Belt Clutch	
		BRAKE: External Band Type	
		Parking Brake Lock Standard Equipment	
	Location	IMPLEMENT LIFT LEVER: Left Side	
		POWER TAKE-OFF CLUTCH LEVER: Left Side	
		TRANSMISSION CONTROL LEVER: Right Side	
		Ignition Key Switch	On Instrument Panel
		Light Switch	
		Throttle Lever	
		Choke Control	
		Ammeter	
PARKING BRAKE LOCK: Lower Right of Seat			
DIMENSIONS	Overall Length	67 Inches (1.7 m)	
	Overall Width	37.5 Inches (952 mm)	
	Height	TO TOP OF DASHBOARD: 35.5 Inches (902 mm)	
		TO TOP OF STEERING WHEEL: 39.25 Inches (997 mm)	
	Weight	BASE WEIGHT: 775 Lbs. (351.5 kg)	
Wheel Base	48.1 Inches (1.2 m)		
TUNE-UP DATE	Spark Plug Type (* indicates type for areas subject to radio noise limitations)	Champion: H - 10 or RH - 10*	
		Autolite: AL7B	
	Spark Plug Gap	STANDARD PLUG: .035 In. (.89 mm). Resistor Plug: .025 In. (.64 mm)	
	Ignition Point Gap	.020 inch (.50 mm)	

Specifications Subject To Change Without Notice

Operating with Attachments

















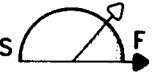

Attachment	Engine Speed Control	Hydrostatic Lever Position	Approx. Ground Speed (MPH)	Required Accessories and Options	Recommended Accessories and Options
Rotary Mower (Smooth terrain-normal grass)			3-5		
Rotary Mower (Rough terrain-heavy or wet grass)			2-4		
Snow Thrower (Use fast ground speed in light snow, slow in wet, heavy snow)			3-4 or 1-2		Tire Chains. 4 Rear Wheel weights. Power Lift Kit.
Snow Plow/ Dozer Blade			3-5		Tire Chains. 4 Rear Wheel weights.
Grader Blade			3-5		4 Rear Wheel Weights
Sickle Bar			3-5		
36" Rotary Tiller			1-2	Rear Lift Kit	4 Rear Wheel Weights Power Lift Kit. Tire Chains
38" Rotary Tiller (Heavy Duty)			1-2	Rear Lift Kit Front Wheel Weights Rear Wheel Weights Electric Lift Kit	Tire Chains
Moldboard Plow			2-3	Rear Lift Kit One-Point Hitch	4 Rear Wheel Weights
Cultivator Spring Tooth Harrow			2-5	Rear Lift Kit One-Point Hitch.	4 Rear Wheel Weights

Figure 22. Attachment Chart

Attachment Operation on Slopes

For your personal safety, always operate your tractor with attachments up and down the face of slopes, and never across the face. Use slow tractor ground speeds on slopes, and use extreme caution when changing direction on any slopes. Do not start or stop suddenly on slopes.

Two rear wheel weights are required to operate your tractor with front or mid-mounted attachments on slopes greater than 20 percent (11.3 degrees); use two front wheel weights for rear mount-

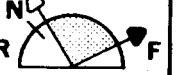
ed attachments. Except for the 38" heavy duty tiller, never operate your tractor with attachments on slopes greater than 35 percent (19.3 degrees), which is a 3-1/2 feet rise in 10 feet forward, and always in an up and down direction. For the 38" heavy duty tiller, never operate on slopes greater than 27 percent (15 degrees), which is a 2.7 feet rise in 10 feet forward.

See your attachment Operator's Manual for more detailed information on normal operation requirements and procedures.

