

Simplicity

OPERATOR'S MANUAL 7000 - 6 SPEED SERIES

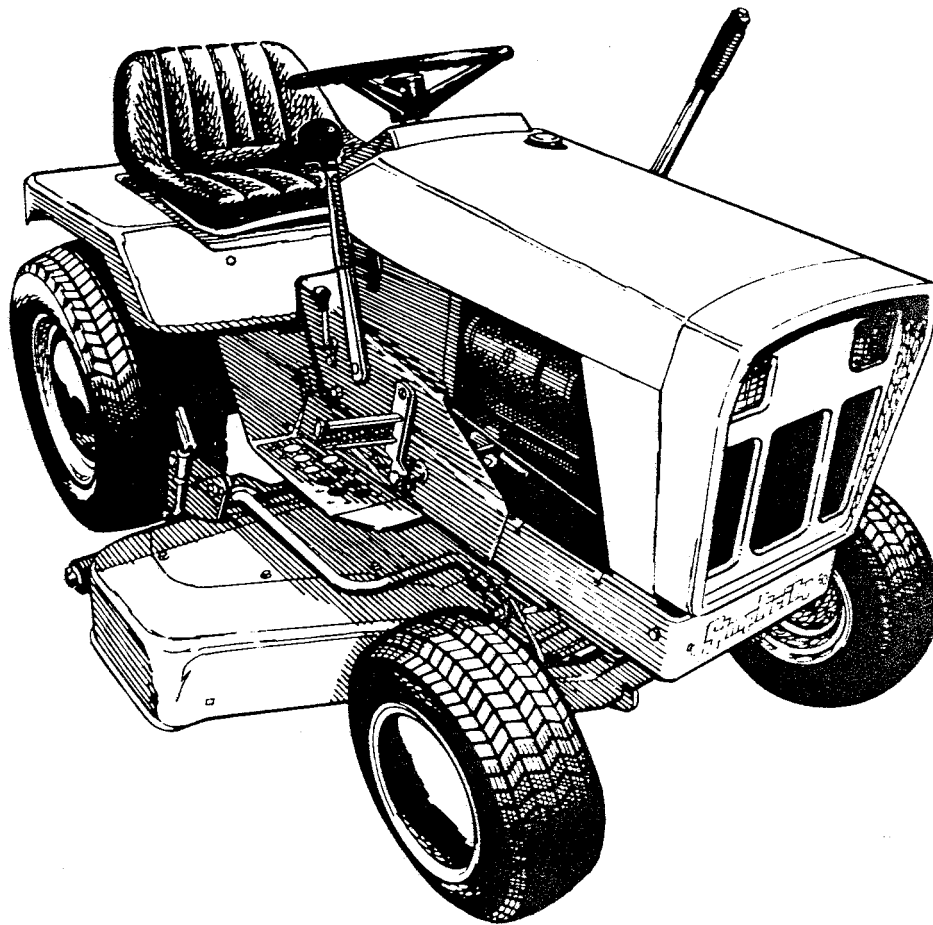

10 H.P. TRACTOR
MFG. NO. 1690204
16 H.P. TRACTOR
MFG. NO. 1690203



**CAUTION: Read Manual Thoroughly
Before Operating Tractor**

FORM - 1656681
PRINTED IN U.S.A.
767

7000-6 Tractor

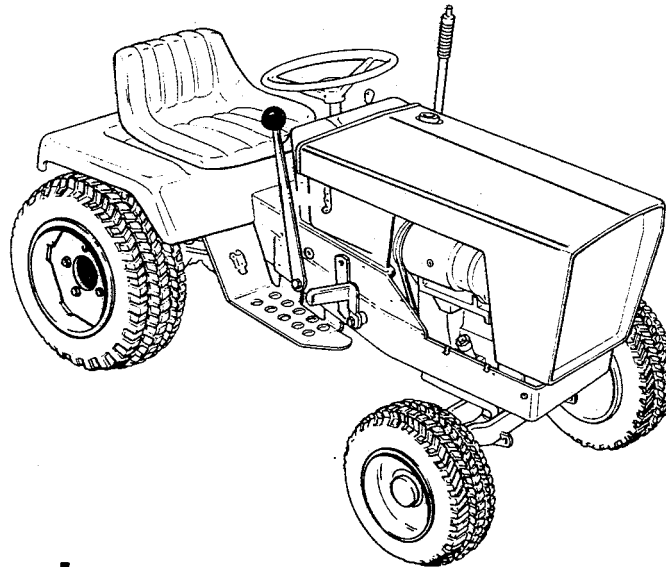

Table of Contents

SAFETY RULES	2
OWNER BENEFITS	3
TRACTOR IDENTIFICATION	4
OPERATION	5
CONTENT OF SECTION	5
TRACTOR CONTROLS	5
OPERATING PROCEDURES	6
NORMAL CARE	9
CONTENT OF SECTION	9
SCHEDULED CARE	9
NORMAL STORAGE	9
OFF-SEASON STORAGE	9
STARTING AFTER STORAGE	10
TROUBLESHOOTING	19
CONTENT OF SECTION	19
TROUBLESHOOTING PROCEDURES	19
ADJUSTMENTS	21
CONTENT OF SECTION	21
ADJUSTMENT PROCEDURES	21
ELECTRICAL SCHEMATIC	28
SPECIFICATIONS	29
ACCESSORIES AND ATTACHMENTS	30
OPERATION CHART	31
MAINTENANCE RECORD	33

Safety Rules This notation preceding Cautions and Warnings in the text signifies important precautionary steps which, if not properly followed, could result in personal injury or damage to your equipment.

General

- Read the Operating and Service Instructions carefully. Be thoroughly familiar with the controls and the proper use of the equipment.
- Never allow children to operate the machine. Do not allow adults to operate it without proper instruction.
- Do not carry passengers.
- Keep the area of operation clear of all persons, particularly small children, and pets.
- When using any attachments, never direct discharge of material toward bystanders nor allow anyone near the vehicle while in operation.
- Make sure
 - a. tractor and attachments are in good operating condition,
 - b. all safety devices and shields are in place and in good working condition, and
 - c. all adjustments (cutting height, etc.), have been made.

Preparation

- Handle gasoline with care — it is highly flammable.
 - a. Use approved gasoline container.
 - b. Never remove the cap of the fuel tank or add gasoline to a running or hot engine, or fill the fuel tank indoors. Wipe up spilled gasoline.
- Do not run the engine indoors. Exhaust fumes are dangerous.
- Clear the work area of objects which might be picked up and thrown.
- Disengage all attachment clutches and shift into neutral before attempting to start the engine.
- Wear heavy footwear. Do not operate tractor when barefoot or when wearing open sandals or canvas shoes.

Operation

- Disengage power to attachments and stop engine before unclogging attachment chutes.
- Disengage power to attachment(s) and stop the engine before leaving the operator's position.
- Disengage power to attachment(s) and stop the engine before making any repairs or adjustments.
- When using the vehicle with mower, proceed as follows:
 - a. Mow only in daylight or in good artificial light.
 - b. Never make a cutting height adjustment while the engine is running.
 - c. Check the blade mounting bolts for proper tightness at frequent intervals.
- Do not stop or start suddenly when going uphill or downhill. Mow up and down the face of steep slopes; never across the face.
- Reduce speed on slopes and in sharp turns to prevent tipping or loss of control. Use extreme caution when changing direction on slopes.
- Stay alert for holes in the terrain and other hidden hazards. Be extra careful when operating on wet or slippery surfaces.
- The vehicle and attachments should be stopped and inspected for damage after striking a foreign object, and the damage should be repaired before restarting and operating the equipment.
- Watch out for traffic when crossing or near roadways.
- If equipment begins to vibrate abnormally — disengage power to attachments and stop engine at once. Inspect for damage and correct before starting up tractor.
- Use care when pulling loads or using heavy equipment.
 - a. Use only drawbar hitch point.
 - b. Limit loads to those you can safely control.
 - c. Do not turn sharply. Use care when backing.
 - d. Use weights when suggested in the owner's manual.
- Disengage power to attachment(s) when transporting or not in use.
- Take all possible precautions when leaving the vehicle unattended, such as disengaging the power take-off, lowering the attachment(s), shifting into neutral, setting the parking brake, stopping the engine, and removing the key.
- Keep the vehicle and attachments in good operating condition, and keep safety devices in place.

Maintenance and Storage

- Keep all nuts, bolts, and screws tight to be sure the equipment is in safe working condition.
- Do not change the engine governor settings or overspeed the engine.
- To reduce fire hazard, keep the engine free of grass, leaves, or excessive grease.
- Never store the equipment with gasoline in the tank inside a building where fumes may reach an open flame or spark. Allow the engine to cool before storing in any enclosure.

Owner Benefits

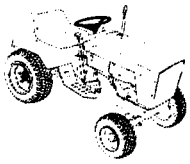

Easy steering — the all-gear steering system is designed to give reliable, fast steering for excellent maneuverability and trouble free long life. The short turning radius allows you to work around tight corners and in confined areas.

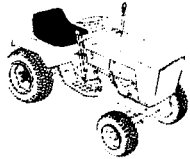

Adjustable 4-position leatherette bonded foam seat assures comfortable, smooth ride.

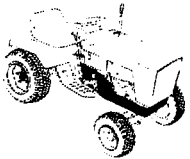

Heavy gauge electrically welded frame of sturdy channel construction takes on rugged jobs with dependable long life operation.

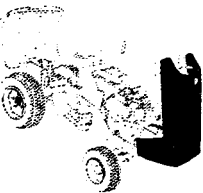

Forward tilting hood and grille makes engine compartment easily accessible for repairs and maintenance. Rearward tilting seat provides easy access to drive train.

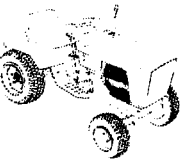

Dependable, rugged engine with mechanical governor assures smooth engine performance under varying load conditions.

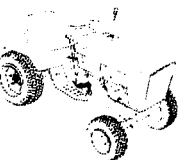

Combined clutch and brake pedal insures safe starting and stopping with easy rocker action.



Large wide tires give comfortable ride and help protect your lawn.

Conveniently located parking brake keeps tractor still when tractor is unattended.

Dash-mounted operating controls are easily accessible and provide quick finger-tip operator response.

7010, 7016 - 6 Speed

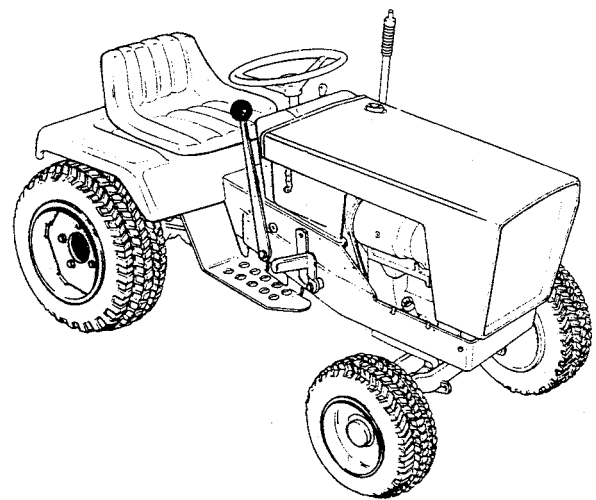

Fast starting under all weather conditions is easier with a heavy duty 12-volt electric starter and generator with 45 ampere, automotive-rated battery. Ammeter included as standard equipment.

Speed range lever gives you six useable forward speeds, suitable for every job.

Dependable all-gear transaxle has limited slip differential, permits traction even when one wheel is on a slippery surface.

Tractor Identification

When ordering replacement parts for your Simplicity tractor, be prepared to give your dealer the identification numbers found on the tractor and engine identification plates shown below. The identification plate for the tractor is located on the frame in front of the tractor seat. The identification plate for the engine is located on the left side of the engine blower housing. We suggest that you locate the numbers and record them below for easy reference.

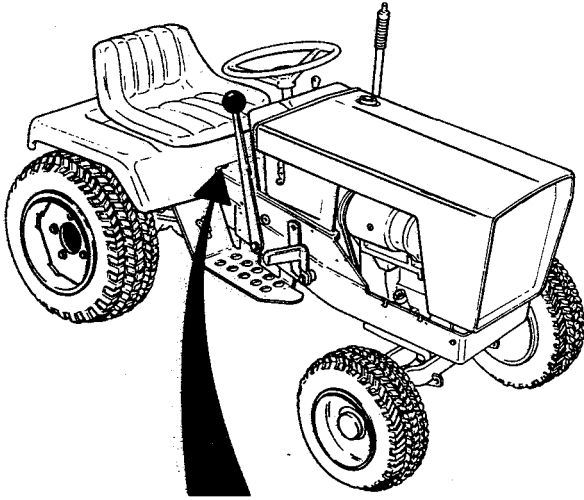

Engine I D

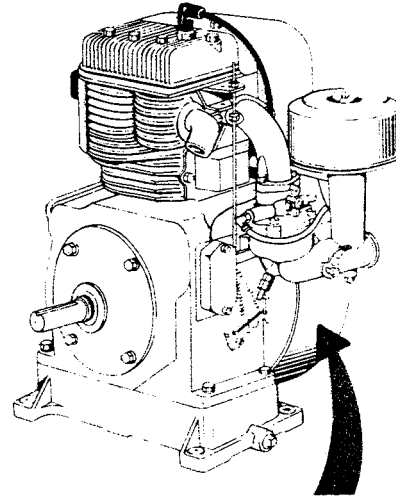

Tractor I D

Operation

CONTENT OF SECTION

This section begins with a brief description of the tractor controls, followed by the basic tractor operating procedures.

TRACTOR CONTROLS

Figure 1 shows the location, name, and function of each of the standard tractor controls. Figure 2 gives the same information for optional controls.

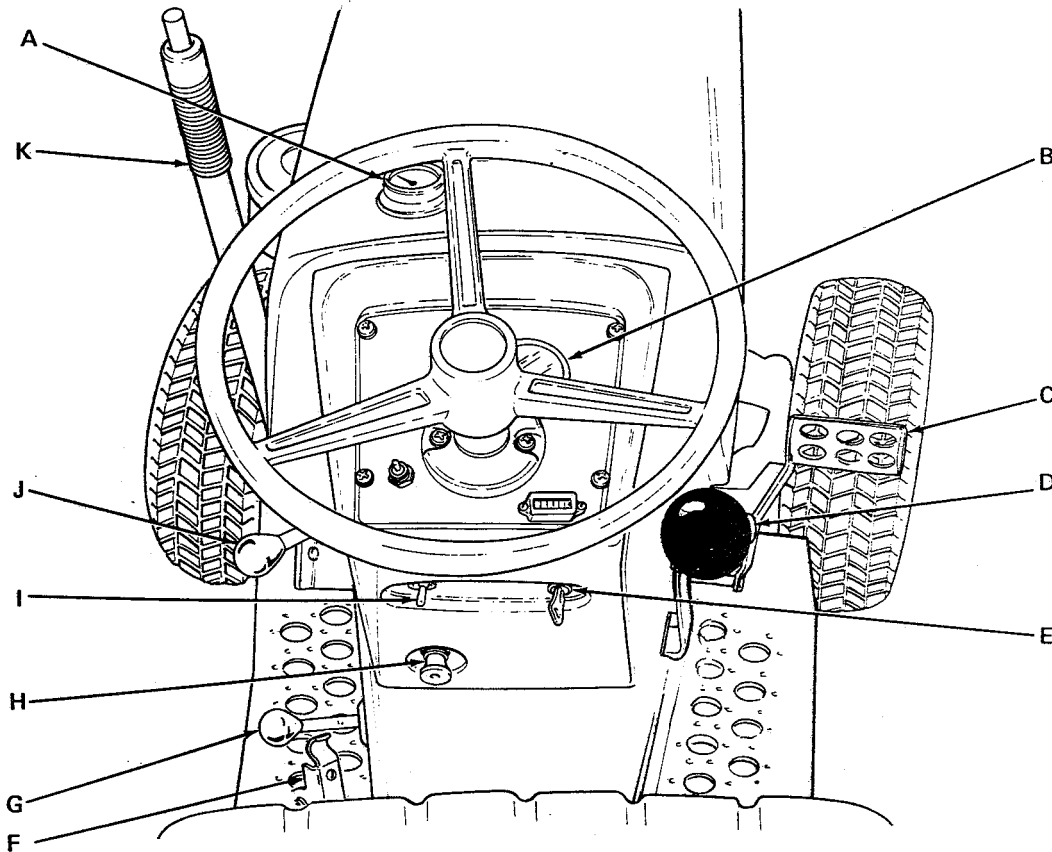

Item	Name	Function
A	Fuel Gauge	Shows fuel level and serves as cap for fuel tank fill pipe.
B	Ammeter	Shows when battery is being charged or discharged.
C	Clutch-Brake Pedal	Controls both main clutch and brake. Disengages clutch when pressed down at least halfway. Applies brake when fully depressed.
D	Speed Range Lever	Shifts tractor speed to high or low range. Clutch must be fully depressed to shift dual range lever.
E	Ignition Switch	Operates with key to start, run, or turn off engine.
F	Parking Brake Lever	Locks brake to hold tractor in parked position.

Item	Name	Function
G	PTO (Power Take Off) Clutch Lever	Operates clutch for power driven attachments. Used to turn center and rear mounted attachments on and off.
H	Choke Control	When pulled out, closes engine choke for starting and warmup in cold weather.
I	Light Switch	Switches tractor headlights on or off.
J	Engine Speed Control	Operates engine throttle to adjust engine speed.
K	Lift Lever	Lifts and locks attachments such as the rotary mower in transport position. Pushbutton atop lever opens lock to lower attachment to work position.

Figure 1. Location and Function of Standard Tractor Controls

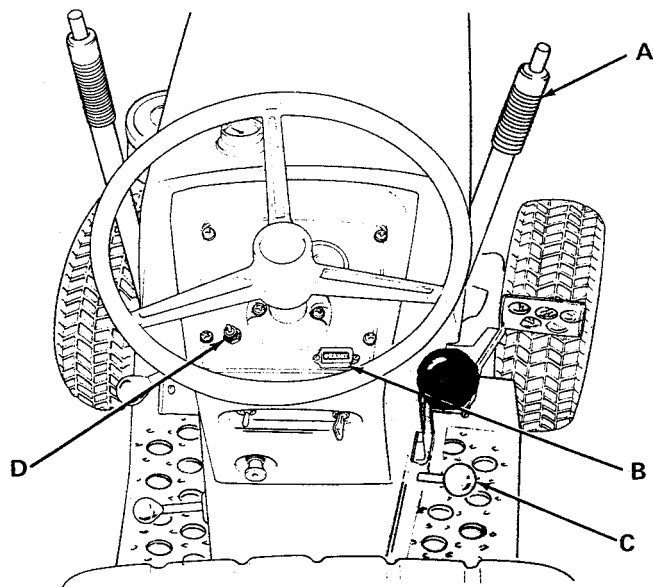

Item	Name	Function
A	Dual Lift Lever	Provides lift control for front-mounted attachments. Used with standard lift lever (item K, figure 1) to provide separate control for two attachments at same time.
B	Hourmeter	Provides easy method of keeping record of tractor operating hours to insure regular care.
C	Front PTO (Power Take Off) Lever	Operates clutch for snow thrower attachment. Used to turn this front mounted attachment on and off.
D	Power Lift Switch	Controls optional electrically operated power lift. When this control is present, the lift lever (item K, figure 1) is removed. The ratchet portion of the lift lever, however, will still be present and can be used as a height indicator.

Figure 2. Location and Function of Optional Tractor Controls

OPERATING PROCEDURES

The remainder of this section contains tractor operating procedures. The procedures assume that the tractor is working properly. If the tractor fails to perform satisfactorily during operation, refer to the troubleshooting procedures in the Troubleshooting Section of this manual.

The procedures in this section have been arranged in the normal sequence of operations commencing with "Checks before Starting" through "Operating with Attachments." The arrangement of these procedures is intended primarily to acquaint you as the operator with the fundamental operating procedures to insure the safe, efficient operation of your tractor. It is recommended that when operating the tractor for the first time that you proceed through the following operational checks in sequence:

- Location and Function of Controls
- Checks Before Starting
- Stopping the Tractor
- Starting the Engine
- Starting Tractor into Motion
- Before Leaving the Tractor

NOTE

When driving the tractor for the first time, start off slowly and drive only on level ground. Get the feel of starting, stopping, and starting again. Then increase speed by moving gear shift lever and the engine speed control.

Before commencing any operations it is essential that you review and become completely familiar with the Safety Rules on page 2.

After you have become familiar with all of the above procedures you should be ready to operate the attachments. Refer to the paragraph in this section titled "Operating with Attachments," the attachment operation chart (page 32), and the appropriate manual for the attachment.

Checks Before Starting

The checks below should be performed before starting the engine for the first time. Repeat these checks each time you use the tractor to insure that it is ready for use.

1. Refer to Normal Care Section of this manual to determine and perform needed care.
2. Seat yourself on the tractor. Try operating some of the controls to see if the seat position

fits you. If not, see the seat adjustment procedure in the Adjustments Section of this manual.

3. Check the fuel gauge. Be sure there is enough fuel in the tank to complete your task. If you need more fuel, fill the tank as follows:

▲ WARNING

Gasoline is highly flammable and must be handled with care. Never fill the tank when the engine is still hot from recent operation. Do not allow open flame, smoking or matches in the area. Avoid overfilling and wipe up any spills.

- a. Remove fuel gauge cap as shown in figure 3.
- b. Fill fuel tank with clean, fresh, leaded or nonleaded regular grade gasoline.
- c. Install and hand tighten fuel gauge cap.

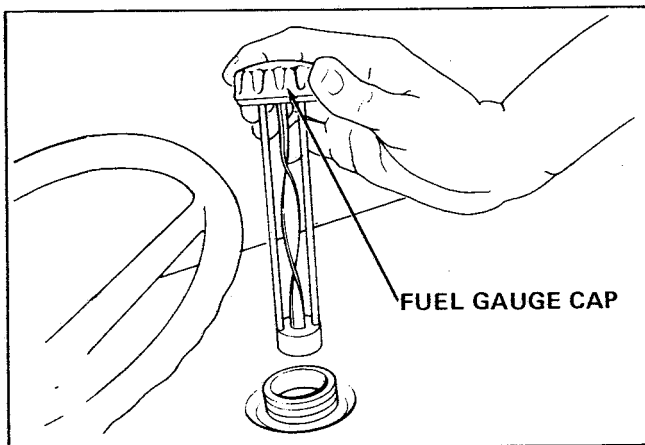

Figure 3. Remove Fuel Gauge Cap

Stopping the Tractor

Tractor motion can be stopped by depressing the clutch-brake pedal. Pressing the pedal down about half-way will give a gradual stop. Pressing the pedal down further will give a more rapid stop by engaging the brake.

Shifting Transmission and Speed Range

The gear shift lever and the speed range lever can be shifted from one position to another after fully depressing the clutch-brake pedal. Do not attempt to shift either lever without depressing clutch-brake pedal fully, or damage to the transmission may result.

To select the high speed range, push the speed range lever fully forward after depressing the clutch-brake pedal. To select the low speed range, pull the lever fully back after depressing clutch-brake pedal.

Figure 4 shows the gear shift pattern. Select the gear and speed range for the speed you desire. For ground speeds of the different gears and speed ranges, see the Specifications section at the end of this manual and the Recommended Operating Speeds Chart following it.

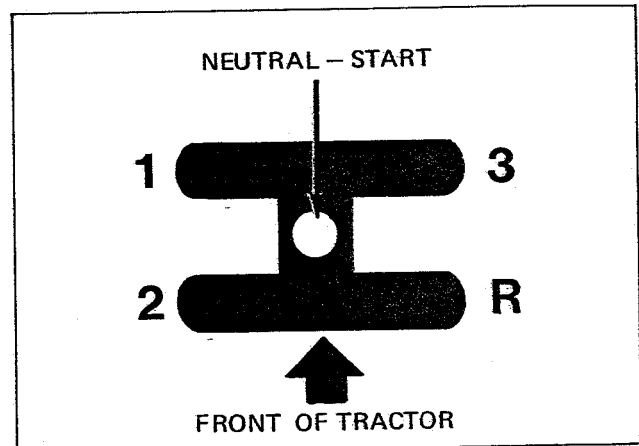

Figure 4. Gear Shift Pattern

Starting the Engine

Complete the "Checks Before Starting" procedures. Then proceed as follows:

▲ WARNING

Do not start or run engine in an enclosed area. Open doors if in garage — exhaust fumes are dangerous.

1. Seat yourself on the tractor.
2. Set parking brake by lifting parking brake lever up and back until it rests against fender.
3. Pull choke control out fully. When engine is warm, it may not be necessary to choke engine.
4. Set engine speed control midway between SLOW and FAST. For cold weather starting, set engine speed control to SLOW for easier starting.
5. Pull PTO clutch lever up and fully back to disengage PTO clutch.
6. Put gear shift lever in neutral-start position.
7. Press clutch-brake pedal down to disengage clutch. Keep clutch disengaged until engine starts.

**WARNING**

Gear shift lever must be in neutral and PTO lever in fully disengaged position before the engine will start.

8. Insert key in ignition switch and turn it to START. The electric starter motor should run. If not, repeat steps 5 and 6.
9. When the engine starts, release the key. It will return to the ON position for normal running.
10. Move engine speed control to SLOW position.
11. As engine warms up, push in choke control.

Starting Tractor into Motion

This procedure describes how to safely start the tractor into motion after starting the engine.

1. Rotate steering wheel to straighten front wheels. Whenever possible, the first motion should be straight forward.
2. Set engine control for 1/3 to 1/2 speed.
3. With the clutch-brake pedal fully depressed, select the gear suited for the operation planned and the speed range desired.
4. Release parking brake.
5. Check that the path is clear in the direction you want to go.
6. Slowly release clutch-brake pedal to engage clutch and set tractor into motion.
7. Adjust engine speed control for desired speed.

Operating with Attachments

This paragraph describes a general procedure for tractor operation with attachments.

1. Insure that attachment is properly installed and ready for use. Refer to attachment manual for details.
2. Start engine.
3. Pull lift lever back to raise attachment.

4. Start tractor into motion and proceed to work site.
5. At work site, bring tractor to complete stop.
6. Unlock lift lever and lower attachment. To unlock lift lever, pull lever back slightly before pressing lock release pushbutton on top of lever.
7. Clear work site of any objects that might be thrown by or get caught in attachment.
8. Set engine speed control for 3/4 speed.
9. Verify that attachment discharge is not directed toward people or pets.
10. If PTO is being used, push PTO clutch lever completely forward and down to engage attachment.
11. Adjust engine speed control and select gear best suited to attachment operation. Refer to attachment operation chart (page 32).
12. Start tractor into motion.

NOTE

Complete remaining steps to return machine to storage.

14. Disengage PTO, and stop tractor motion.
15. Raise attachment to travel position.
16. Resume tractor motion to return to storage site.

Before Leaving Tractor

To prevent accidents, perform steps below before leaving tractor seat.

1. Disengage PTO, and stop tractor motion.
2. Set engine control to SLOW.

NOTE

Stopping a hot engine too suddenly can cause engine damage. Move engine control to SLOW and idle engine for about one minute before stopping engine.

3. Set parking brake.
4. Lower attachments.
5. Shift to neutral.
6. Turn ignition key to OFF and remove key.

Normal Care

CONTENT OF SECTION

Your tractor was designed and built to provide years of service with only minor care. Certain tasks however, must be performed to keep the tractor in good operating condition and to avoid costly repairs. This section tells how to give the necessary care for the tractor. To service an attachment, refer to the separate manual for that attachment.

SCHEDULED CARE

A schedule for routine care is provided in figure 5. We suggest that you check these items to insure that the tractor is ready for use. Performing the checks will also help you to become familiar with the care of the tractor.

All other scheduled care is performed after operating the tractor for a specific amount of time. See figures 6 through 14. Remember to perform the "every 25-hour check" when you perform the "every 100-hour check."

Because the schedule is based on operating time, it will be necessary to determine or estimate the actual operating time. This is easily accomplished if your tractor is equipped with an optional hour meter. If not, you can determine normal times for regular jobs such as cutting your lawn. Multiply these normal times by the number of times you perform the jobs to estimate total operating time.

A Maintenance Record (figure 33) is provided to help you document all operating hours and maintenance repair actions.

NORMAL STORAGE

To protect your tractor, store it in an enclosed dry area. Do not store it in an enclosure where fumes from the fuel tank could reach an open flame without first draining the fuel tank.

To store your tractor in a cold area between winter snow removal jobs, we suggest that you fill the fuel tank after the completion of each job to prevent water condensation in the fuel tank.

If you do not intend to use your tractor during the winter months, follow the off-season storage instructions given in the paragraph below.

OFF-SEASON STORAGE

When the tractor is to be stored for two months or longer, take precautions as follows:

NOTE

Fuel may be stored in the tank or in a container for longer periods if a gasoline stabilizer is used. This additive, available from your dealer, prevents formations of gum and varnish for up to one year.

1. Drain fuel tank if stabilizer is not used. This can be done by removing the fuel hose at the engine and draining the hose into a container.

Care Required	See Figure	Schedule				
		Before First Use	Every 5 Hours	** Every 25 Hours	Every 100 Hours or Annually	*** Spring and Fall
Check Tractor and Engine	6	•	•			
Clean Engine and Air Filter	7			•		
Change Engine Oil*	8			•		•
Lubricate Tractor	9	•		•		
Check Fluid Levels and Tire Pressure	10	•		•		
Check Transmission Oil Level	11	•			•	
Clean Battery and Cables	12				•	
Clean or Replace Spark Plug and Fuel Filter	13				•	
Repack Front Wheel Bearings	14				•	

*Change original engine oil after first 5 hours of operation.
 **More often in hot (over 70° F) weather or dusty operating conditions.
 ***Only if tractor is used in both summer (over 40° F) and winter (under 40° F).

Figure 5. Summary of Scheduled Care

2. After reconnecting fuel hose, run engine until it stops.
3. Change engine oil while the engine is still warm. (See figure 8.)
4. Remove spark plug. Pour one ounce of 10W-30 oil into engine through spark plug hole. Crank engine a few times to distribute oil and then reinstall the spark plug.
5. Lubricate tractor. (See figure 9.)

⚠ WARNING

Battery fluid is a strong, sulfuric acid solution which could cause serious personal injury or property damage when working with the battery. Do not allow battery fluid to come in contact with skin, eyes, fabrics, or painted surfaces. Use care to prevent accidental spills of the acid.

6. Check battery fluid level. (See figure 10.) Battery life will be increased if it is removed and stored in a cool, dry place and fully charged about once a month.

7. At end of storage period, follow instructions in the "Starting after Storage" paragraph which follows.

STARTING AFTER STORAGE

Before starting the tractor after a period of off-season storage, perform the following:

1. Remove spark plug and wipe dry. Crank engine a few times to blow excess oil out of plug hole. Then reinstall the plug.
2. Fill fuel tank with fresh gasoline (unless a fuel stabilizer was used).
3. Clean engine fins and air filter. (See figure 7.)
4. Check fluid levels and tire pressure. (See figures 10 and 11.)
5. If it was removed, install battery. (See figure 12.)
6. Start the engine outdoors or in a well ventilated area. Do not run engine at high speeds immediately after starting.

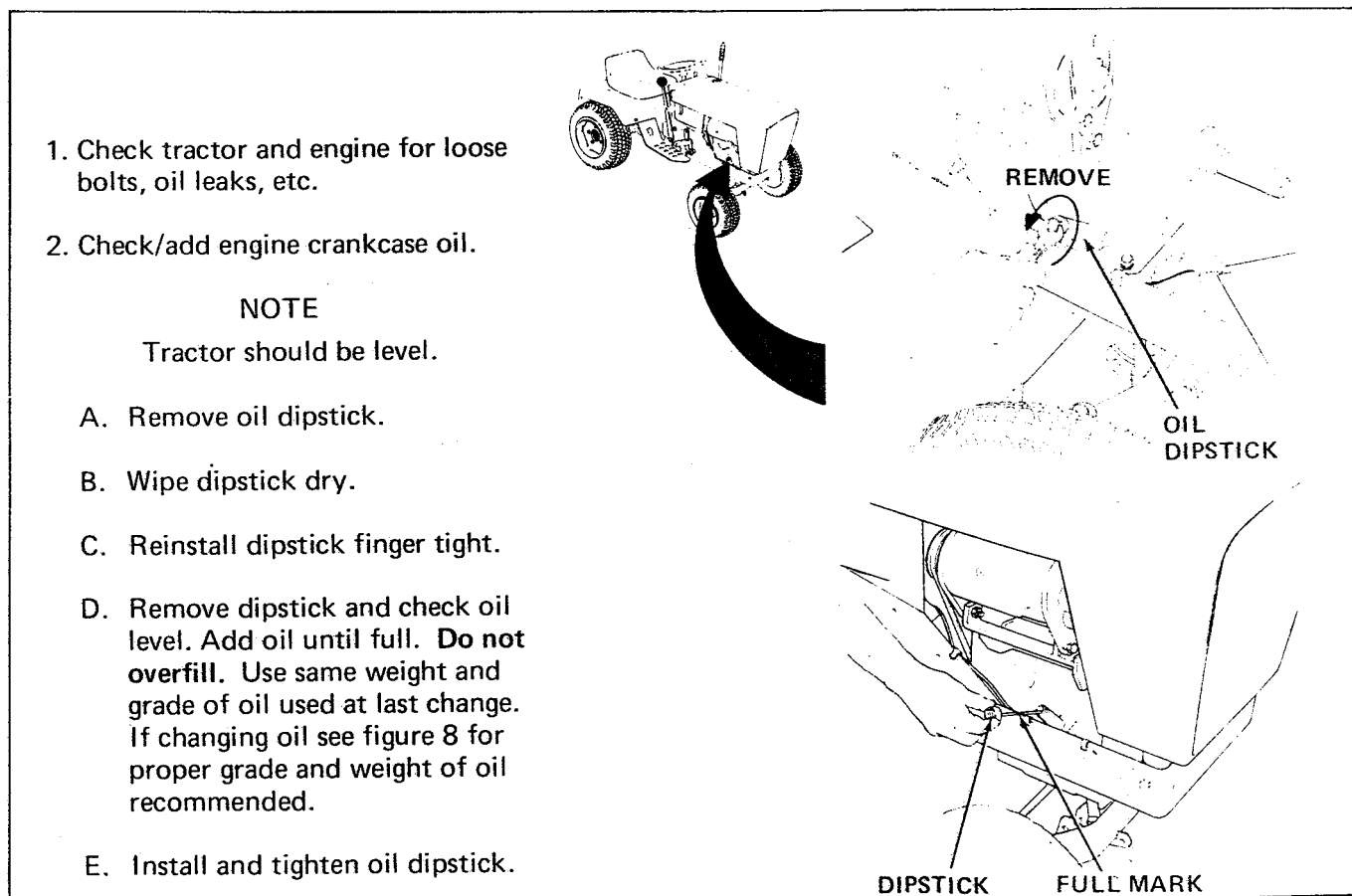

1. Check tractor and engine for loose bolts, oil leaks, etc.
2. Check/add engine crankcase oil.

NOTE

Tractor should be level.

- A. Remove oil dipstick.
- B. Wipe dipstick dry.
- C. Reinstall dipstick finger tight.
- D. Remove dipstick and check oil level. Add oil until full. **Do not overfill.** Use same weight and grade of oil used at last change. If changing oil see figure 8 for proper grade and weight of oil recommended.
- E. Install and tighten oil dipstick.

Figure 6. Check Tractor and Engine (5-Hour Care)

NOTE

Cleaning is important to avoid overheating and engine damage. More frequent cleaning is recommended after operation in dusty or muddy conditions or after cutting dry grass.

1. Clean all dirt and grass from engine fins. Remove cover as necessary.
2. Clean engine blower screen.

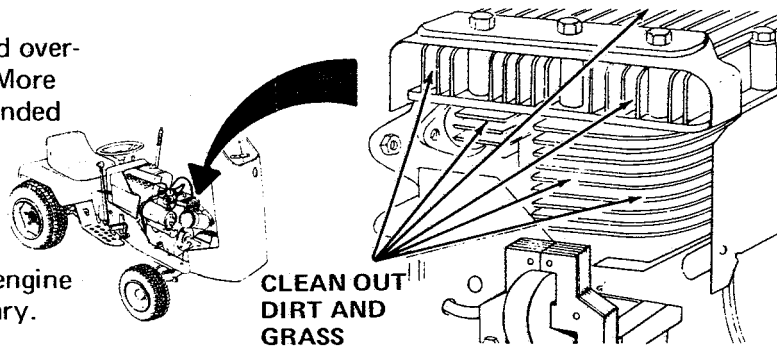

3. Clean engine air filter.

- A. Remove upper wing nut and cover.
- B. Remove foam sleeve.
- C. Wash foam with kerosene or soap and water.
- D. Dry foam.
- E. Soak foam with lightweight oil; squeeze several times to spread oil evenly and to remove excess.
- F. Yearly or every 100 operating hours, whichever occurs first, remove and clean paper cartridge. Clean by tapping gently on flat surface. If very dirty, replace cartridge, or wash in liquid detergent and water. Rinse until water remains clear. Cartridge must be air dried thoroughly before using.
- G. Install foam, cover, and upper wing nut.

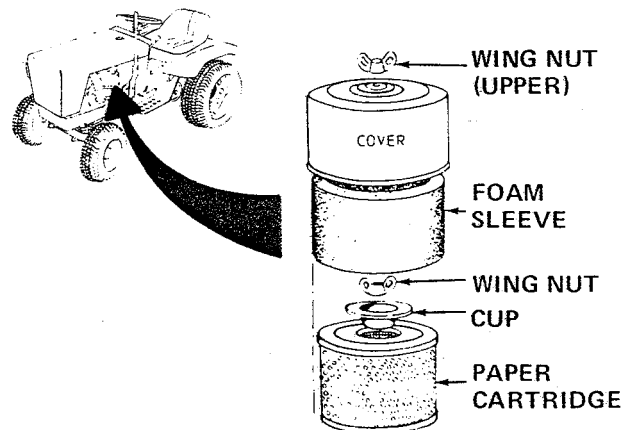
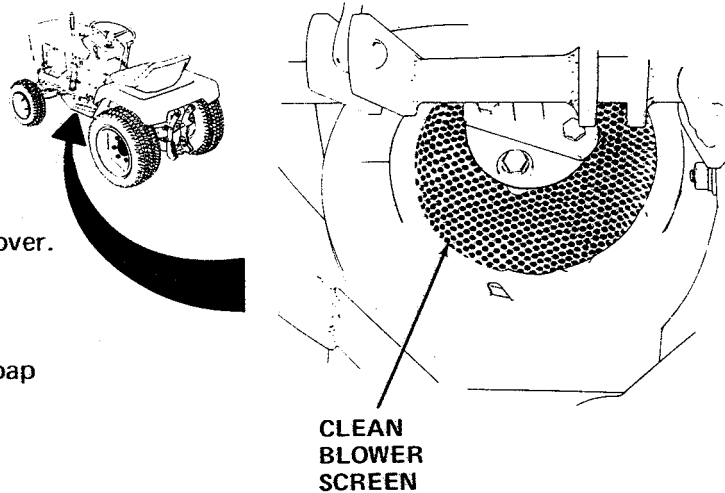
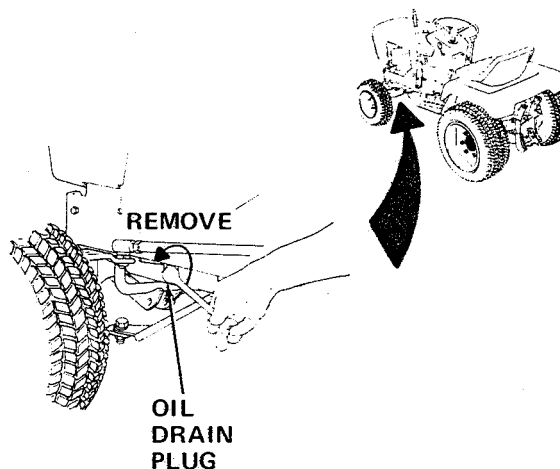

Figure 7. Clean Engine and Air Filter (25-Hour Care); or as required.

NOTE

Change oil while engine is still warm from operation.

1. Remove drain plug.
2. Drain old oil.
3. Install and tighten drain plug.



NOTE

DON'T POLLUTE: Dispose of drain oil properly.

4. Remove oil dipstick.

CAUTION

To avoid engine damage, use only high quality detergent oil of the correct grade and weight. The grade (service) marking on the can may be MS, SE, SC, or SD. The correct weight varies with the season as follows:

Summer	Winter
(Above 40° F) Use SAE 30, or SAE 10W-30.	(Between 0 & 40° F) Use SAE 5W-20 or SAE 5W-30.
	(Below 0° F) Use SAE 10W or SAE 10W-30 diluted 10% with kerosene.

5. Add new oil until level reaches full mark on dipstick. Remember to install dipstick finger tight during checks. Pour slowly and check often with dipstick. Capacity is about 2 quarts.
6. Install and tighten oil dipstick.

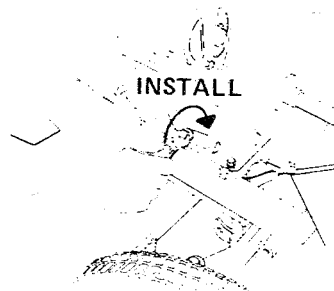
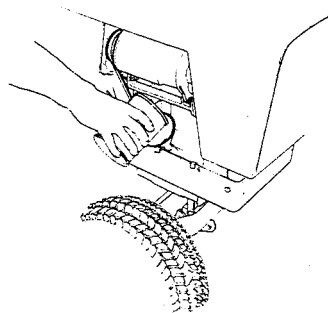
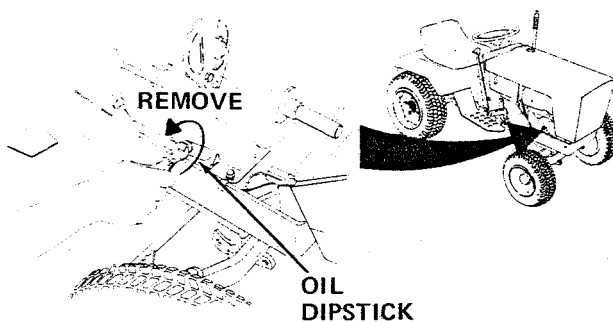
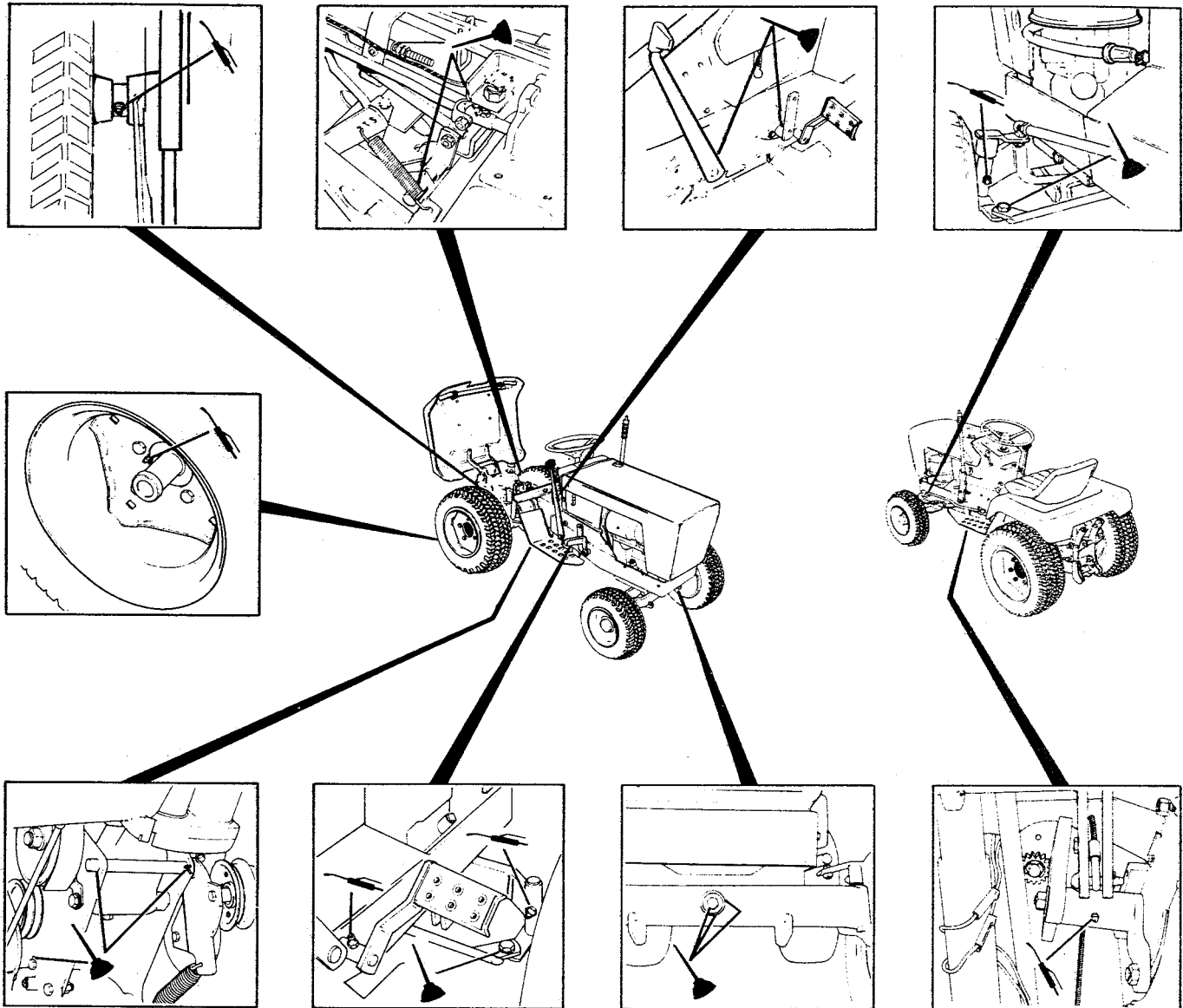

Figure 8. Change Engine Oil (25-Hour Care)



NOTE

Keep grease and oil off belts and pulleys.



Symbol	Use	Apply With	Procedure
	Lithium base automotive grease	Grease gun	<ol style="list-style-type: none"> 1. Wipe fitting clean with rag. 2. Apply 2 or 3 shots of grease. 3. Wipe up any excess grease.
	Medium weight (SAE 30) oil	Oil can	<ol style="list-style-type: none"> 1. Brush and wipe dirt and grass from area. 2. Apply a few drops of oil. 3. Wipe up any drips or spills.
	Lithium base automotive grease	Brush	<ol style="list-style-type: none"> 1. Wipe area clean of old grease and dirt. 2. Apply thin film of grease with hand or brush.

Figure 9. Lubricate Tractor (25-Hour Care)

NOTE

Allow 10 minutes after operation before checking bevel gear box fluid level.

1. Check bevel gear box fluid level.

- A. Remove fill plug.
- B. Fluid should touch tip of fill plug when plug is loosely installed in hole. If not, add SAE 90 weight transmission fluid.
- C. Install and tighten fill plug.

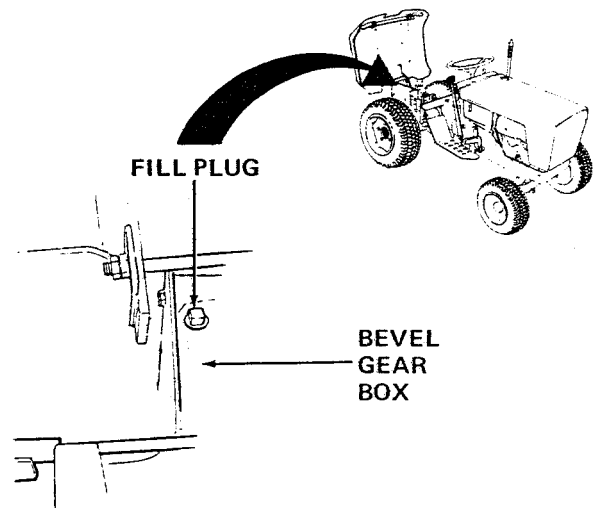
**2. Check battery fluid level.**

- A. Remove filler caps, one at a time.
- B. Fluid must be even with split ring full mark. If not, add distilled water to refill.
- C. Install filler caps.

**3. Check air pressure of all four tires.**

Figure 10. Check Fluid Levels and Tire Pressures (25-Hour Care)

1. Remove fill plug.
2. Fluid should be level with the bottom of the threads of fill plug elbow.
3. If it is not, add SAE 90 oil to bottom of threads.
4. Replace and tighten fill plug.

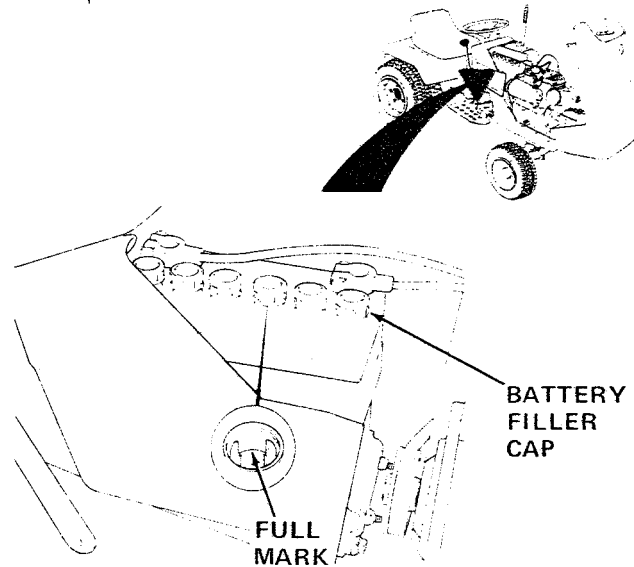
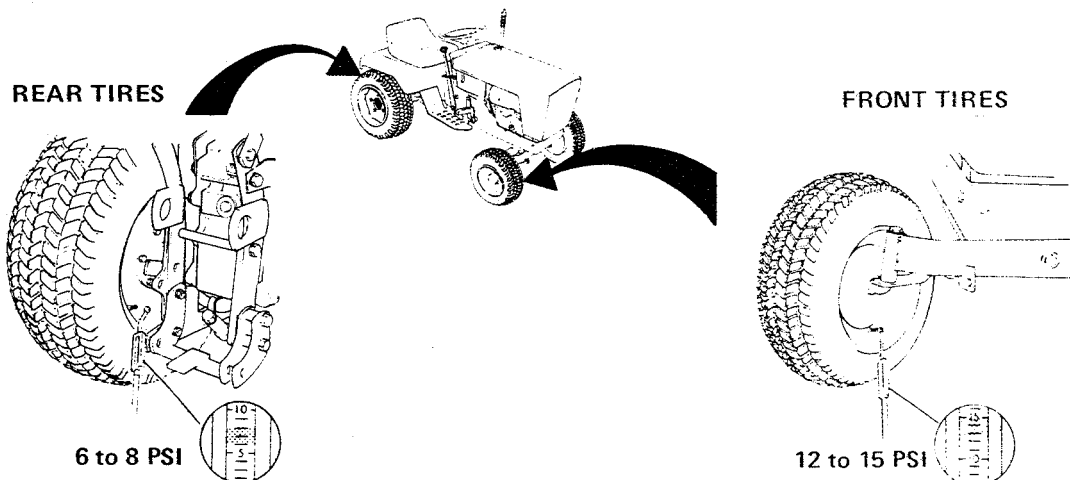
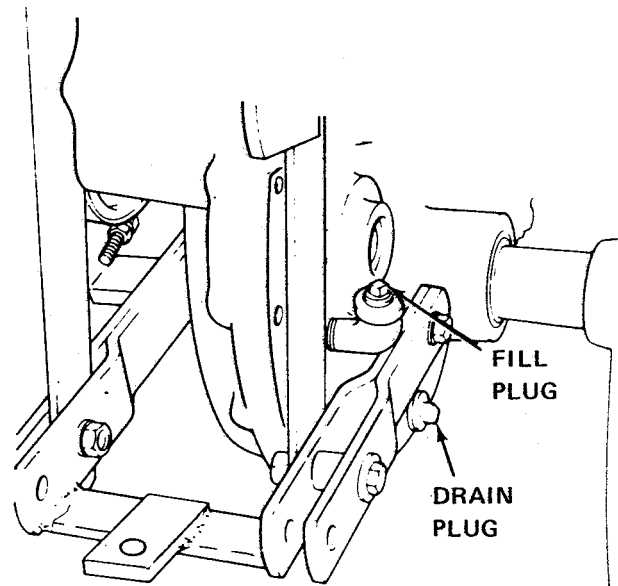

NOTE

If transmission shows any evidence of leaking (oil seeping through seals, drips, etc.) check oil level more often.

If the transmission oil becomes contaminated with foreign matter (sand, water, etc.) for some reason, drain transmission completely, flush thoroughly with clean solvent, and refill with fresh SAE 90 transmission oil.

Figure 11. Check Transmission Fluid (100-Hour Care)

⚠ CAUTION

The positive battery terminal can be easily shorted to the tractor frame by a wrench or other tool. To avoid this problem, always disconnect the negative cable first and connect it last.

⚠ 1. Remove cables, negative cable first.

2. Loosen battery clamp.

3. Remove battery.

4. Scrub battery, cables, and battery compartment. Use baking soda and water.

5. Clean terminals and cable clamps with wire brush.

6. Install battery and tighten battery clamp.

⚠ 7. Install cables, positive cable first.

8. Coat cable clamps and terminals with grease or vaseline.

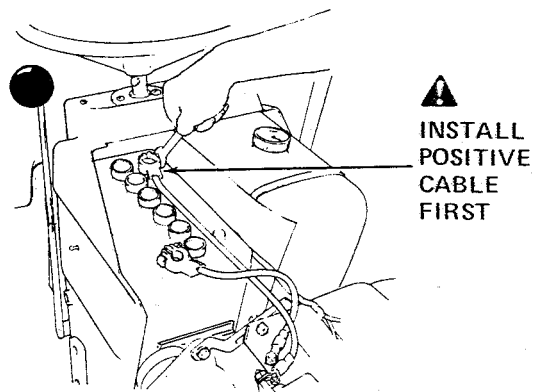
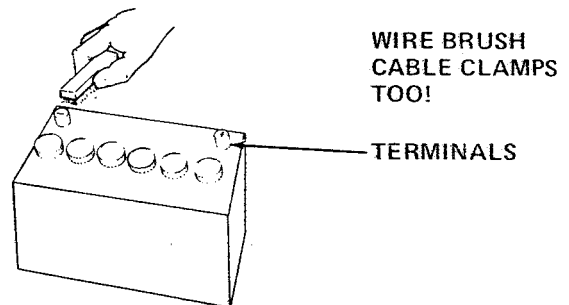
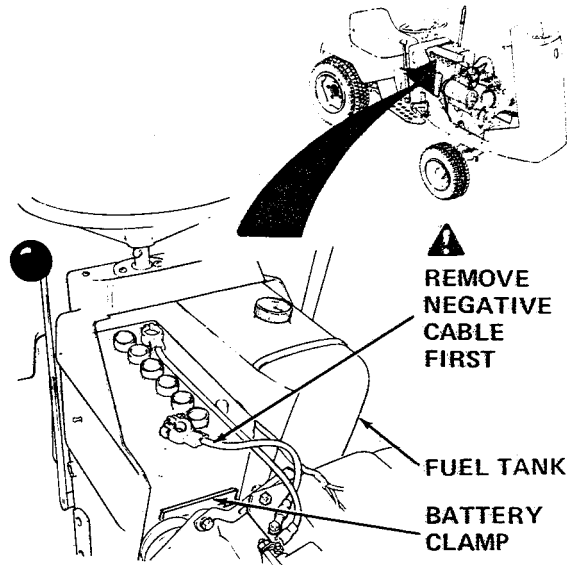

Figure 12. Clean Battery and Cables (100-Hour Care)

1. Clean or replace spark plug.

A. Remove spark plug.

CAUTION

Do not clean spark plug by sand-blasting; sand or grit that remains on plug may damage engine.

B. Clean spark plug. If plug shows signs of defects, it should be replaced with a new plug.

C. Set gap at .030 inch.

D. Install spark plug in engine and reconnect wire.

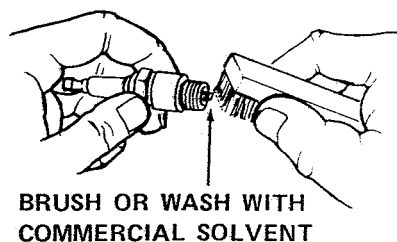
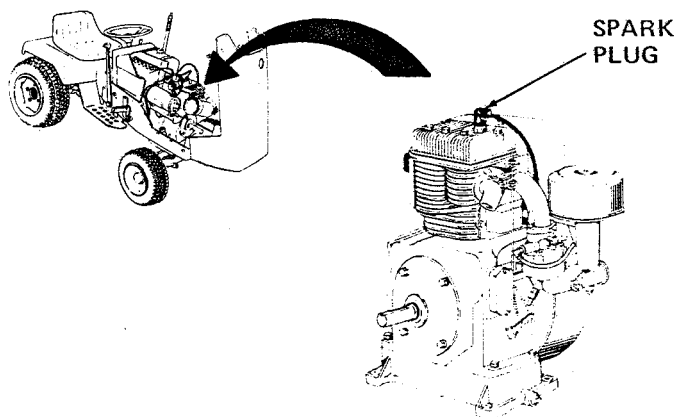

2. Clean or replace fuel filter.

WARNING

Do not remove fuel filter while engine is hot. Gasoline spills will occur. For your safety, review safety rules for handling of gasoline. Do not spread hose clamps further than necessary. Insure clamps grip hoses firmly over filter during installation.

A. Using pliers, open and slide hose clamps from fuel filter.

B. Remove hoses from fuel filter.

C. To clean old filter, wash in solvent. Blow out any residue with air hose in opposite direction of fuel flow.

D. Install new or cleaned filter in hoses. Secure by reclamping with hose clamps.

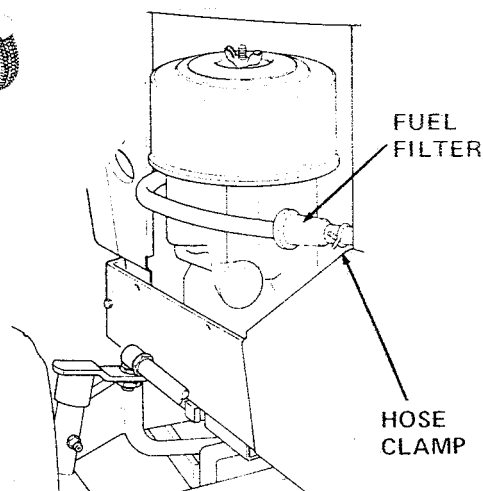
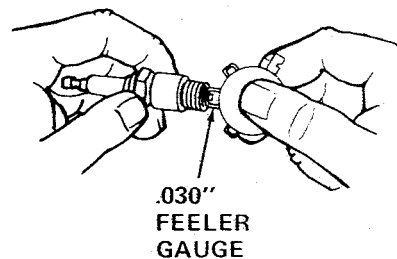
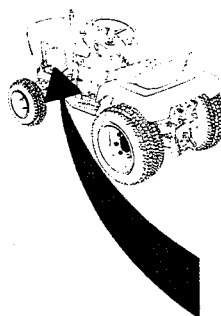
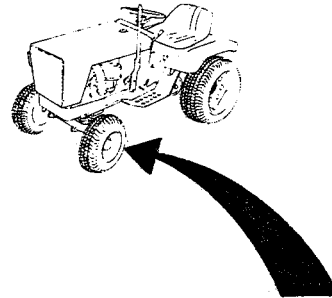

Figure 13. Clean or Replace Spark Plug and Fuel Filter (100-Hour Care)

1. Block or jack up front of tractor for wheel removal.
2. Pry off grease cup with a screwdriver or a claw hammer.
3. Loosen collar setscrew using an Allen wrench.
4. Remove collar, washer and outer bearing.



NOTE

Keep the two bearings separate. Each should be put back in its original place.

5. Remove wheel and inner bearing.
6. Wash wheel shaft, bearings and internal part of wheel. Use a solvent and remove all old grease. Wipe dry.
7. Inspect seal. If seal is damaged, replace it.

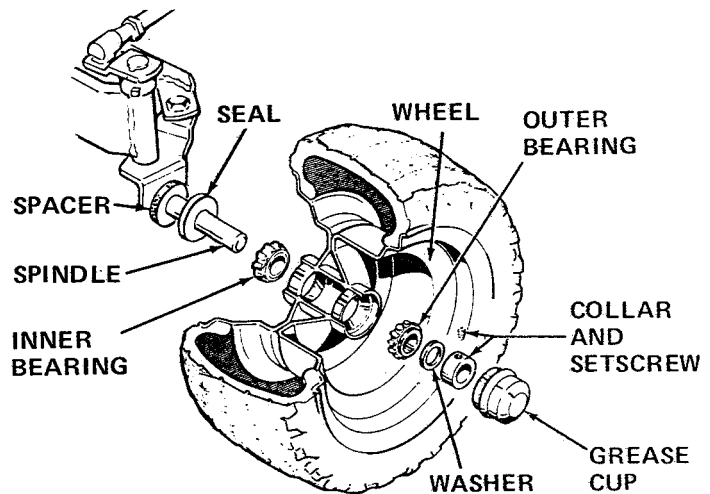

NOTE

Use only a prime quality wheel bearing grease. Keep grease clean and free of dirt.

8. Coat seal and spindle with grease.
9. Lubricate bearings completely with grease. Use hand to force grease and fill spaces between bearing rollers.
10. Install inner bearing and wheel on axle.
11. Install outer bearing, washer and collar.
12. Press collar towards tractor and spin wheel slowly to seat bearings.

13. When wheel and bearings are seated and against seal, hold collar and tighten setscrew securely.
14. Test seating by attempting to wobble wheel. If wobble is more than just evident, loosen setscrew and repeat steps 13 and 14.
15. Replace grease cup and wipe up any excess grease.
16. Repeat entire procedure for other wheel.

Figure 14. Repack Front Wheel Bearings (100-Hour Care)

Troubleshooting

CONTENT OF SECTION

This section of the manual provides troubleshooting and repair instructions for the more common and easily corrected problems. For other problems, it is recommended that you contact your dealer.

▲ WARNING

To avoid serious injury, perform maintenance on the tractor only when the engine is stopped. Always remove the ignition key to prevent accidental starting of the engine before beginning any maintenance.

TROUBLESHOOTING PROCEDURES

Troubleshooting procedures are provided in figure 15. To use these procedures, first locate the problem description that best describes the trouble that you have encountered. Check the possible causes one at a time in the order that they are listed. Correct any problems that are found and operate the tractor again to verify that you have eliminated the trouble.

Problem	Cause
1. Starter motor does not run.	<ul style="list-style-type: none"> A. Transmission control lever not in neutral position. B. PTO clutch lever(s) not in disengaged position. C. Circuit breaker tripped. Wait one minute for automatic reset. Replace, if defective. D. Wiring loose or broken. Visually check wiring and replace broken or frayed wires; tighten loose connections. E. Battery terminals are corroded and require cleaning. F. Battery discharged or dead. Charge or replace as necessary. G. Starter motor generator defective.
2. Starter runs, but engine will not start.	<ul style="list-style-type: none"> A. Out of fuel. Refill fuel tank. B. Engine flooded. Push in choke and attempt to start. C. Crankcase oil too heavy. If so, replace oil per specifications in figure 8. D. Spark plug faulty, fouled, or poorly gapped. E. Water in fuel. Drain fuel and refill with fresh fuel. F. Old stale gas. Drain fuel and replace with fresh fuel. G. Starter-generator belt loose and requires adjustment. H. Points worn or out of adjustment.
3. Engine starts hard or runs poorly.	<ul style="list-style-type: none"> A. Fuel mixture too rich. Push in choke all the way. Clean air filter. B. Carburetor adjusted incorrectly. C. Spark plug or points faulty, fouled, or poorly gapped. D. Water in fuel. Tank, lines and filter must be drained and dried.

Figure 15. Troubleshooting Procedures

Problem	Cause
4. Engine knocks.	A. Low oil level. Check/add oil as required. B. Using wrong grade of oil. C. Engine worn, needs maintenance.
5. Excessive oil consumption.	A. Engine running too hot. Clean engine fins and blower screen. B. Using wrong weight of oil. C. Too much oil in crankcase.
6. Engine exhaust is black or smoky.	A. Dirty air filter. Clean air filter. B. Choke not fully open. Push in choke completely and be sure it opens fully; check carburetor adjustment.
7. Engine runs, but tractor will not drive or lacks power.	A. Transmission not in gear. B. Parking brake engaged. C. Drive belt slips. (See problem and causes below.)
8. Speed Range lever binds or will not shift.	A. Clutch-brake pedal not fully depressed. B. Linkage out of adjustment. See adjustments section.
9. Drive belt slips.	A. Clutch free-travel or idler tension is incorrectly adjusted. B. Pulleys or belt greasy or oily and require cleaning. C. Clutch rod binding in guide; oil clutch rod. D. Belt stretched or worn. Replace with correct belt.
10. Brake will not hold.	A. Brake (foot pedal or parking) is incorrectly adjusted. B. Brake lining is worn and requires replacement.
11. Tractor handles poorly.	A. Steering linkage is loose. Tighten any loose connections. B. Improper tire inflation. Check and correct. C. Wheels are spinning or slipping. Use weights to provide additional stability and traction. D. Moving too fast on slopes. Reduce speed. E. Steering requires lubrication.

Figure 15. Troubleshooting Procedures (continued)

Battery Replacement

A dead battery or one too weak to start the engine may not mean the battery needs to be replaced. It may, as an example, mean that the generator is not

charging the battery properly. If there is any doubt about the cause of the problem, see your dealer. If you need to replace the battery, proceed as shown in the battery cleaning procedure (figure 12).

Adjustments

CONTENT OF SECTION

This section contains adjustment procedures for the tractor and engine. The adjustments are normally performed only to correct specific problems. Because of the need for access to perform the adjustments, procedures for raising the seat deck and hood are also included in this section.

▲ WARNING

To avoid serious injury, perform adjustment procedures on the tractor only when the engine is stopped. Always remove the ignition key before beginning the adjustment procedures to prevent accidental starting of the engine.

Raising the Hood

The hood may be raised to the position shown in figure 16. With the hood raised, parts in the engine area are easily reached. Raise the hood as follows:

1. Pull the rubber straps (figure 16) down and away from the holddown pins.
2. Raise the hood to the position shown in figure 16.
3. When your tasks in the engine area are completed, lower the hood to its normal position. Then pull the rubber straps over the hold-down pins to lock the hood in place.

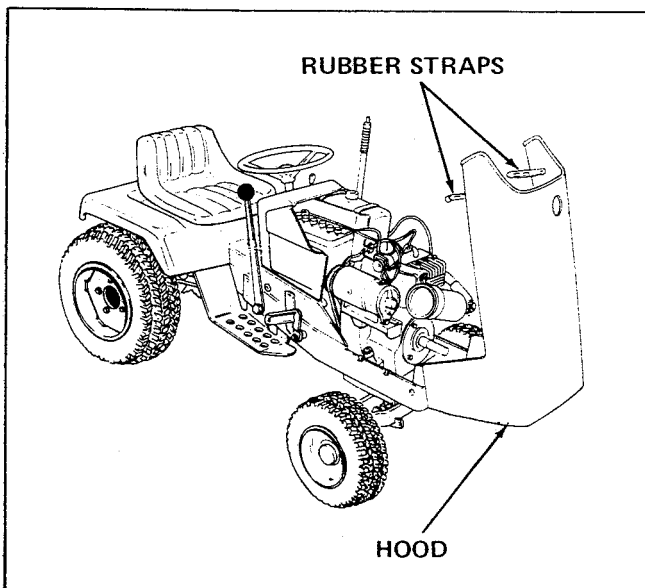

Figure 16. Raising the Hood

Raising the Seat Deck

The seat deck may be raised to the position shown in figure 17. This will expose many of the transmission and clutch-brake adjustment points. To raise the seat deck, proceed as follows:

1. Reach under the seat deck and locate the locking levers (figure 17).
2. Press upward at the tips of both locking levers and raise the seat to the upright position.
3. When you have completed your tasks, push the seat deck down again until it locks in place.

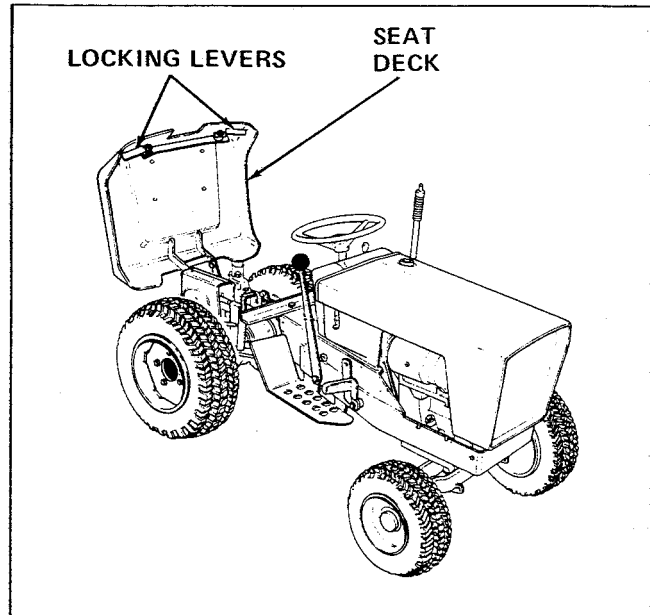

Figure 17. Raising the Seat Deck

ADJUSTMENT PROCEDURES

Seat Adjustment

The seat may be moved forward or backward to any of four different positions to suit different sized operators. To move the seat, proceed as follows:

1. Raise the seat deck.
2. Remove the two capscrews and lockwashers (item A, figure 18).
3. Remove the two nuts and lockwashers (item B).

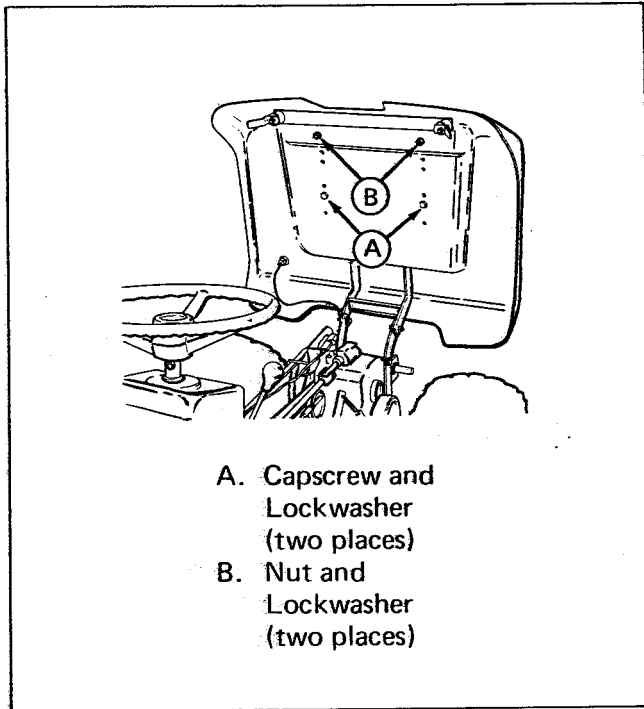

Figure 18. Seat Adjustment

NOTE

Rubber spacers are installed over the studs held by the nuts. These spacers must be between the seat and the seat deck when using the two front sets of mounting holes. When using one of the two rear sets of mounting holes, the spacers must be under the seat deck.

4. Move the seat to the desired set of mounting holes.
5. Install and tighten the lockwashers and nuts (item B).
6. Install and tighten the lockwashers and capscrews (item A).
7. Lower and lock the seat deck in place.

TRANSMISSION CONTROLS ADJUSTMENT PROCEDURES

The following adjustments are for the clutch and brake controls, as well as the speed range lever control. They should be checked in the order given, since one adjustment may affect those given later. Check these adjustments in the following order:

- Parking Brake Adjustment
- Idler Pulley Arm Adjustment
- Transmission Pulley Belt Retainer Adjustment
- Idler Tension Adjustment
- Clutch Rod Clearance Adjustment
- Transmission Brake Adjustment
- Pulley Brake Adjustment

Parking Brake Adjustment

The parking brake should prevent the tractor from rolling when the engine is stopped. Adjust the parking brake as follows:

1. Loosen jam nut (item A, figure 19).
2. After insuring that tractor is on level ground or that wheels are blocked to prevent tractor movement, release parking brake by pushing handle (item B) down.
3. Rotate parking brake handle one complete turn in a clockwise direction to tighten brake.
4. Check adjustment by setting brake. If it is difficult to set, it is too tight. If it is too loose, return to step 2.
5. When proper adjustment has been obtained, tighten jam nut (item A).

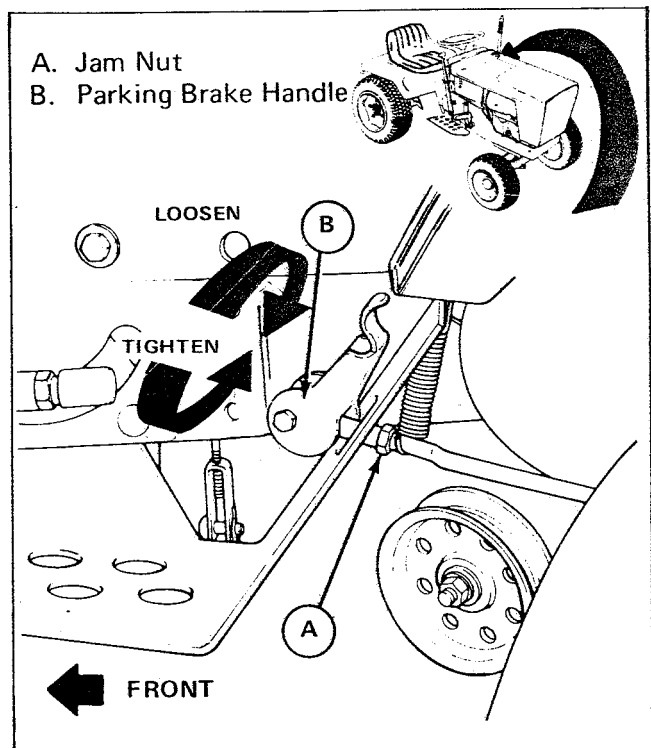

Figure 19. Parking Brake Adjustment

Idler Pulley Arm Adjustment

This adjustment is necessary only if the idler pulley does not line up properly with the drive belt when the clutch is in the engaged position or if it binds on the gate finger. If the idler pulley arm needs adjustment, proceed as follows:

1. Push the speed range lever fully forward so that the idler arm is against the right rear side plate.
2. Loosen setscrew in hub of cam lever. (See figure 20).
3. With the idler arm against the right sideplate, move the cam lever so that it is flush against the left edge of the gate finger (figure 20).
4. Tighten setscrew firmly in cam lever, depress clutch-brake and move speed range lever back and forth from Lo range to Hi range, checking that the cam lever does not bind on the gate finger.

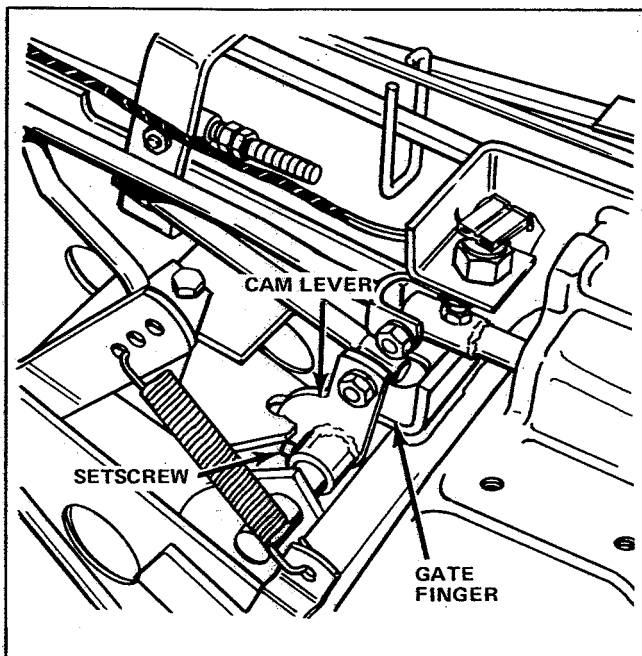

Figure 20. Idler Pulley Arm Adjustment

Transmission Pulley Belt Retainer Adjustment

The transmission pulley belt retainer should be adjusted so that there is 1/16-1/8 inch clearance between the edge of the retainer and the large outside pulley on the transmission. (See figure 21.) The retainer should follow the curve of the pulley evenly. If necessary, bend the retainer so that its edge follows the curve of the pulley evenly.

1. If the retainer needs adjustment, loosen the two capscrews which hold the retainer.
2. Move the retainer until the proper clearance is reached.
3. Hold the retainer in place while tightening the two capscrews in the transmission.

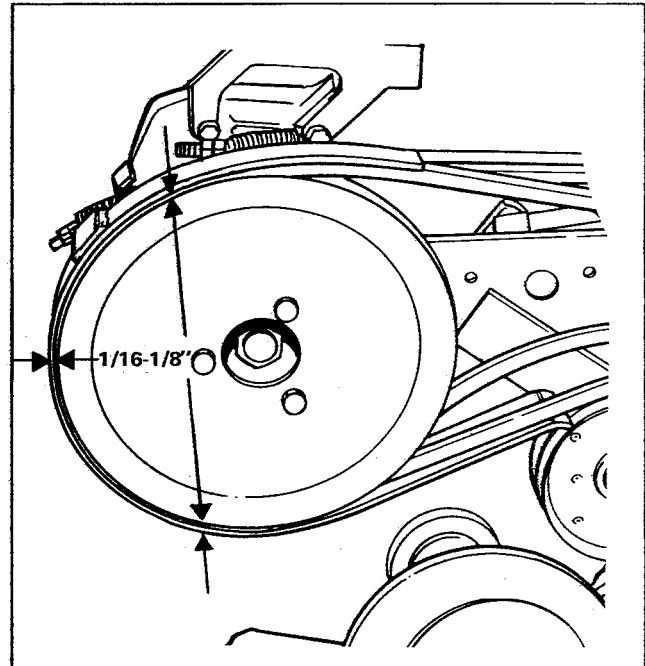

Figure 21. Transmission Pulley Belt Retainer Adjust.

Idler Tension Adjustment

To check idler tension adjustment, place the speed range lever between Hi and Lo positions and release the clutch. Spring tension will hold the cam lever on the gate finger.

1. There should be 1/8-1/4 inch clearance between the outside belt and the top edge of the idler pulley, when the belt is resting on the front and rear belt retainers. (See figure 22).
2. If there is not 1/8-1/4 inch clearance, loosen the nut holding on the idler pulley and move the pulley up or down as needed.
3. When the proper clearance is reached, firmly tighten the nut holding on the pulley.

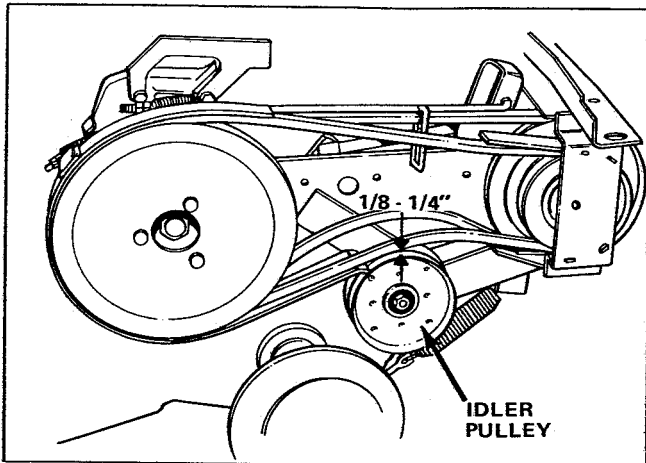

Figure 22. Idler Tension Adjustment

Clutch Rod Clearance Adjustment

1. Shift the speed range lever to Hi, and release the clutch.
2. Pull back firmly on the clutch rod (figure 23). There should be a 3/8 inch gap between the clutch rod guide and the clutch rod adjusting nut.
3. If the clearance is not 3/8 inch, loosen the locking nut from the adjusting nut, and turn the adjusting nut in or out to obtain the 3/8 gap.
4. When the proper gap is reached, hold the adjusting nut with a wrench and tighten the locking nut to it firmly.

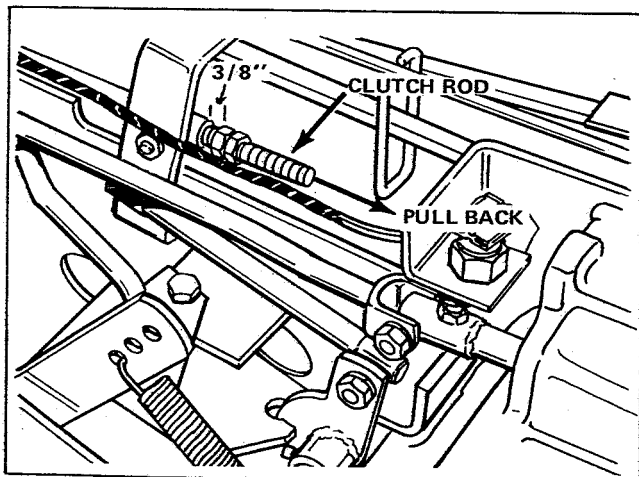

Figure 23. Clutch Rod Clearance Adjustment

Transmission Brake Adjustment

1. With the clutch-brake pedal depressed, move the speed range lever half-way between the Hi and Lo positions, so that the cam lever is directly in front of the gate finger.
2. Place a 0.030 inch feeler gauge between the cam lever and the gate finger, and release the clutch-brake pedal. The spring tension will hold the feeler gauge between the cam lever and gate finger (figure 24).
3. Engage the parking brake by pulling the parking brake handle up firmly so that it holds the brake band tight against the brake drum.

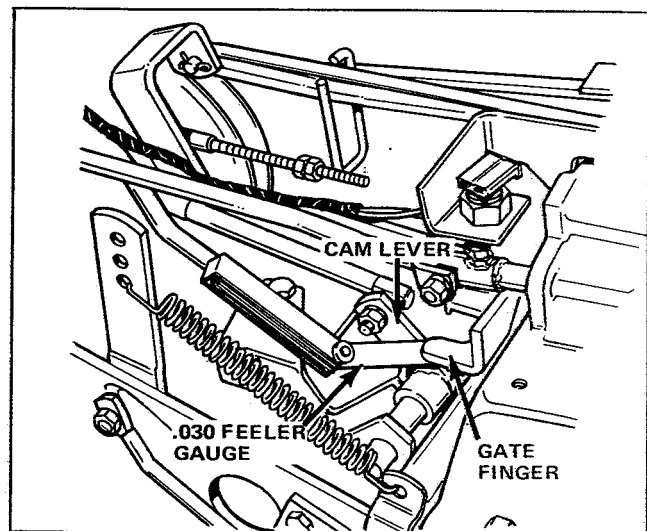

Figure 24. Transmission Brake Adjustment

4. Turn the adjusting nut on the brake rod (figure 25) finger tight against the brake band. Hold the adjusting nut in that position while tightening the locking nut firmly to it.

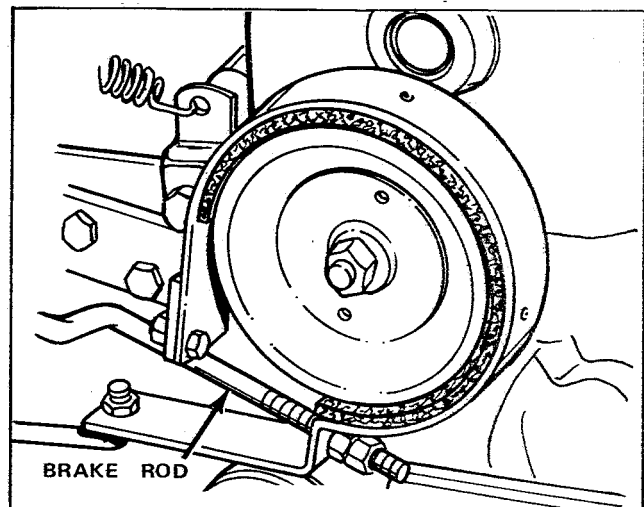

Figure 25. Brake Rod Adjustment

Pulley Brake Adjustment

1. The pulley brake return spring (figure 26) should be compressed enough so that it measures 1 3/8 inches with the clutch-brake pedal released (up). If it does not, loosen the adjusting nut and move it to obtain the proper measurement.

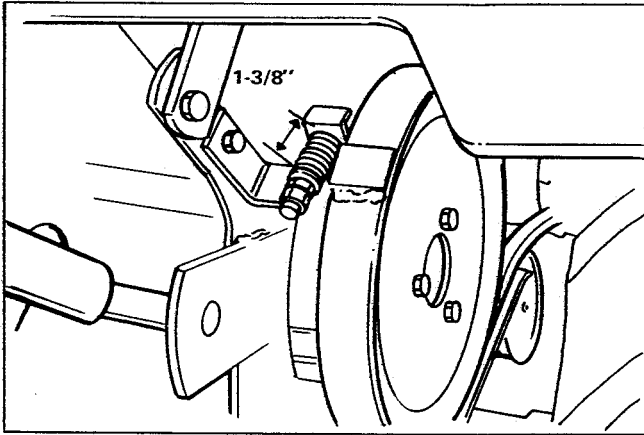

Figure 26. Pulley Brake Adjustment

2. After adjusting the pulley brake return spring, press the clutch-brake pedal down fully to engage the brake.
3. While holding the clutch-brake pedal down fully, measure the length of the large spring on the pulley brake rod (figure 27). It should be compressed to 1 3/4 inches. If it is not 1 3/4 inches, loosen the adjusting nut and move it forward or back until the proper measurement is reached. Then hold adjusting nut and tighten the locking nut firmly to it.

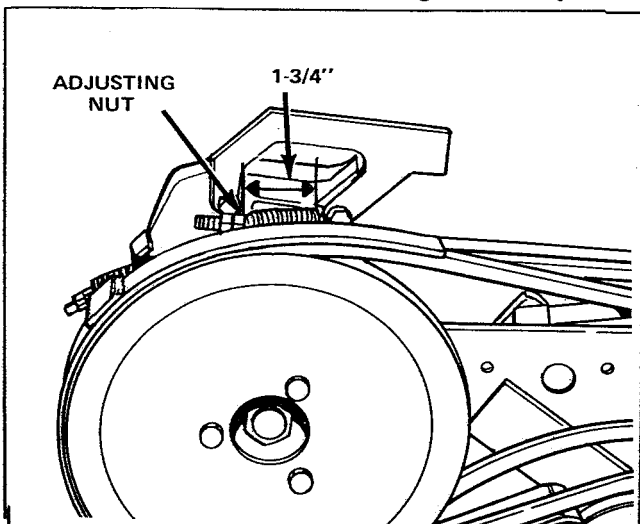

Figure 27. Pulley Brake Rod Adjustment

PTO Clutch Adjustment

PTO clutch adjustment may be required if the clutch fails to engage or disengage a PTO driven attachment. To check the adjustment, raise the seat deck. Then observe the movement of the pulleys (item C, figure 28) in relation to the cup (item D) as the PTO clutch lever is moved from the engaged to the disengaged position. The pulley movement should be 1/8 inch. If not, adjust the PTO clutch as follows:

1. Set PTO clutch lever to engaged position.
2. Loosen the rear nut (item B).
3. Turn the front nut (item A) slightly clockwise to increase pulley travel or slightly counter-clockwise to decrease pulley travel.
4. Tighten the rear nut against the front nut and repeat the check.
5. Lower and lock the seat deck in place.

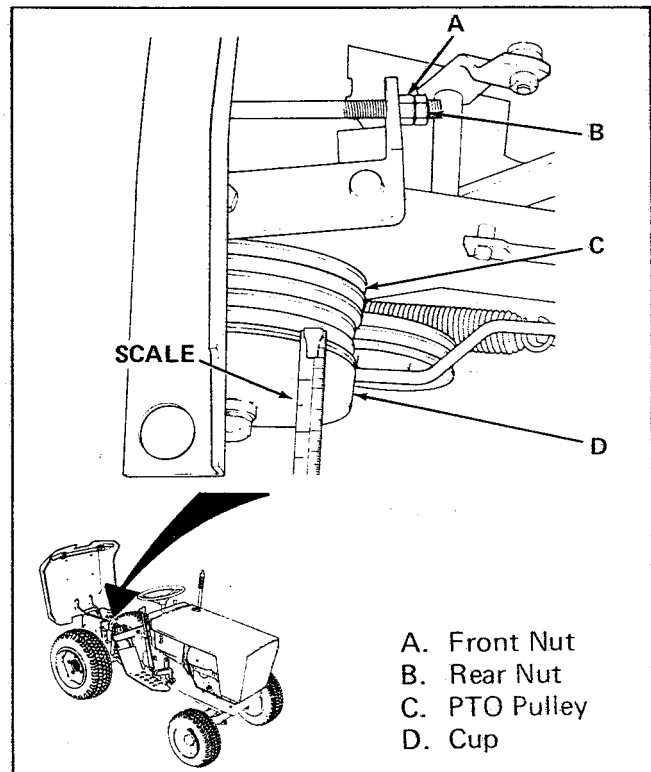

Figure 28. PTO Clutch Adjustment

Starter-Generator Belt Adjustment

If the starter turns, but the engine does not rotate, the starter-generator belt may need tightening. Proceed as follows:

1. Raise the tractor hood.
2. Loosen, but do not remove, the two nuts (item B), the capscrew (item D) and the nut (item E) shown in figure 29.
3. Use a pry bar (item A) between the starter-generator and the engine block to apply pressure that will tighten the belt (item C). The belt should be tight enough so thumb pressure at the midpoint of the belt moves the belt about 1/4 inch.
4. While holding the pry bar to maintain belt tension, tighten the mounting nut (item E) securely.
5. Remove pry bar and try to start engine. If belt slips, loosen the nut (item E) and return to step 3 to tighten the belt further.
6. When belt is properly tightened, securely tighten the two nuts (item B) and the cap-screw (item D).
7. Lower and lock hood in place.

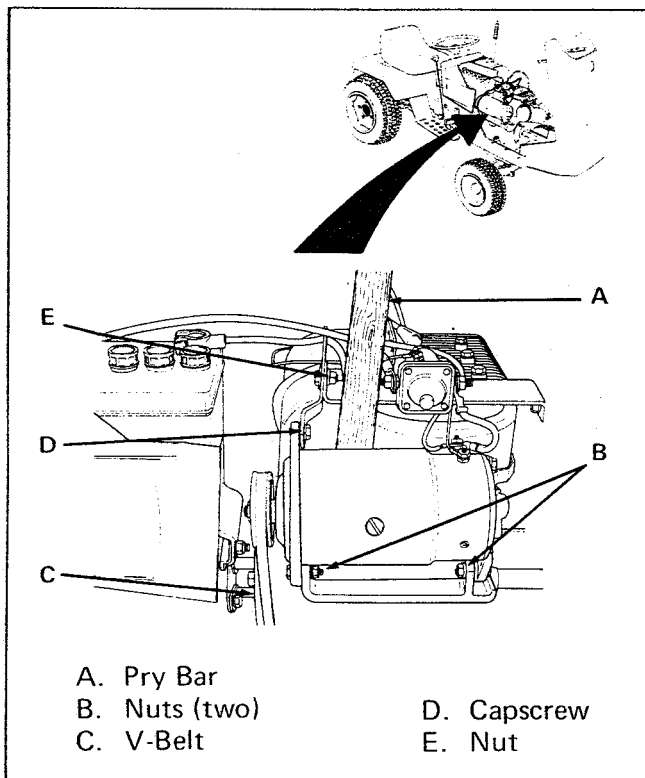

Figure 29. Starter-Generator Belt Adjustment

Clean and Adjust Contact Points

Remove cover. Clean points (item C, figure 30) with a carborundum contact point stone. Then insert a hard finished card or piece of paper and close and open points. The paper will absorb any dirt or filings on the points. Adjust breaker points as follows:

1. Disconnect wire from spark plug.
2. Actuate starter until points open to widest gap.
3. Loosen locknut (item B).
4. Adjust screw (item A) until breaker point gap is 0.020 inch.
5. Tighten locknut (item B).
6. Reinstall cover on breaker point box. Apply sealant over wire entry point in cover (D).
7. Reconnect wire to spark plug.

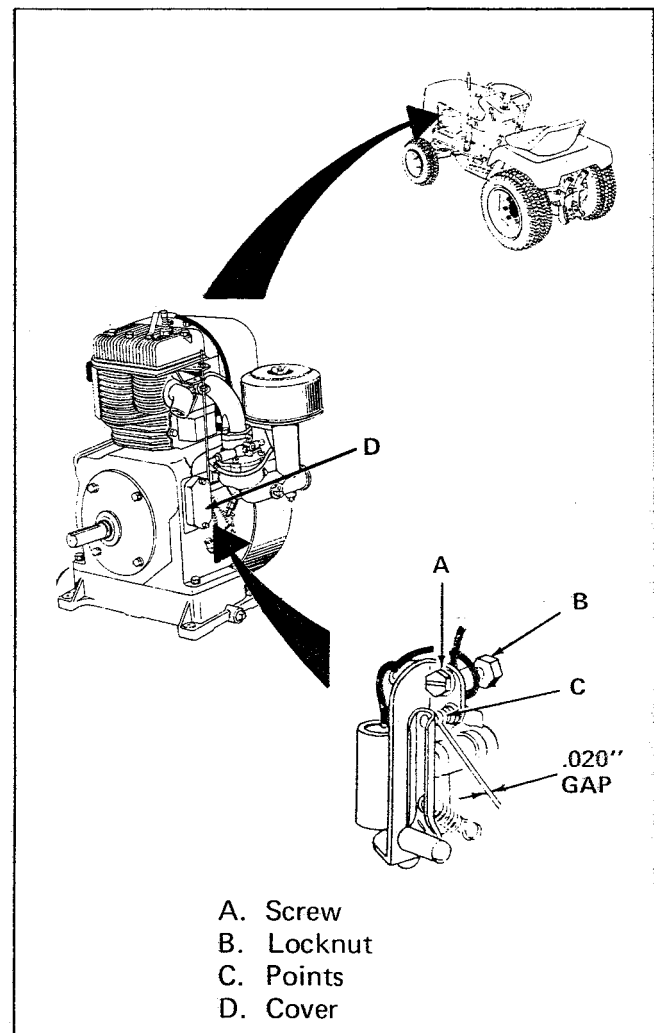

Figure 30. Breaker Points (Cover Removed)

Carburetor Adjustment

The carburetor is adjusted at the factory. However, additional adjustment may be required to compensate for fuel, altitude and load changes. The adjustment procedure is given in two parts: initial adjustment and final adjustment. Perform the initial adjustment only if the engine fails to start.

Initial Adjustment. Perform the initial adjustment of the carburetor as follows:

NOTE

Do not overtighten the needle valve (item C, figure 31). The needle valve is easily damaged when overtightened.

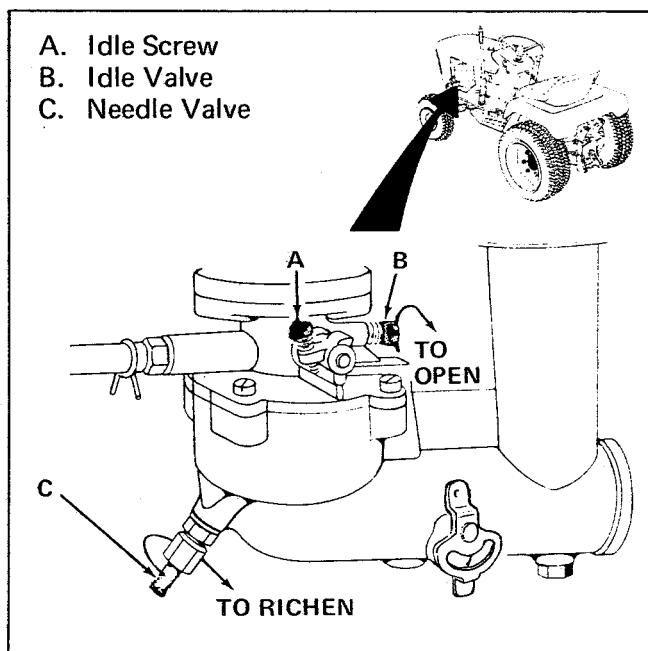

Figure 31. Carburetor Adjustment

1. Turn needle valve (item C) clockwise (in) until it just closes.
2. Open needle valve (item C) one and one-half turns counterclockwise.
3. Turn idle valve (item B) clockwise until it just closes.
4. Turn idle valve (item B) counterclockwise one-half to three-quarters of a turn.

Final Adjustment. To perform the final, fine adjustment of the carburetor, proceed as follows:

1. Start engine and allow it to warm up.
2. Set engine speed control to FAST position.
3. Turn needle valve (item C, figure 31) in (clockwise) until engine begins to miss to find lean mixture position.
4. Turn needle valve (item C) out (counterclockwise) past smooth operating point until engine runs unevenly to find rich mixture position.
5. Now turn needle valve (item C) to a point midway between the lean and rich mixture positions found in steps 3 and 4.
6. Set engine speed control to SLOW position.
7. Adjust idle screw (item A) for fast (1200 RPM) engine idle speed.
8. Turn idle valve (item B) in or out until engine idles smoothly.
9. Repeat adjustment of idle screw (item A) as described in step 7.
10. Operate engine speed control. Engine should accelerate without hesitation or sputtering. If not, readjust needle valve (item C) for slightly richer mixture.

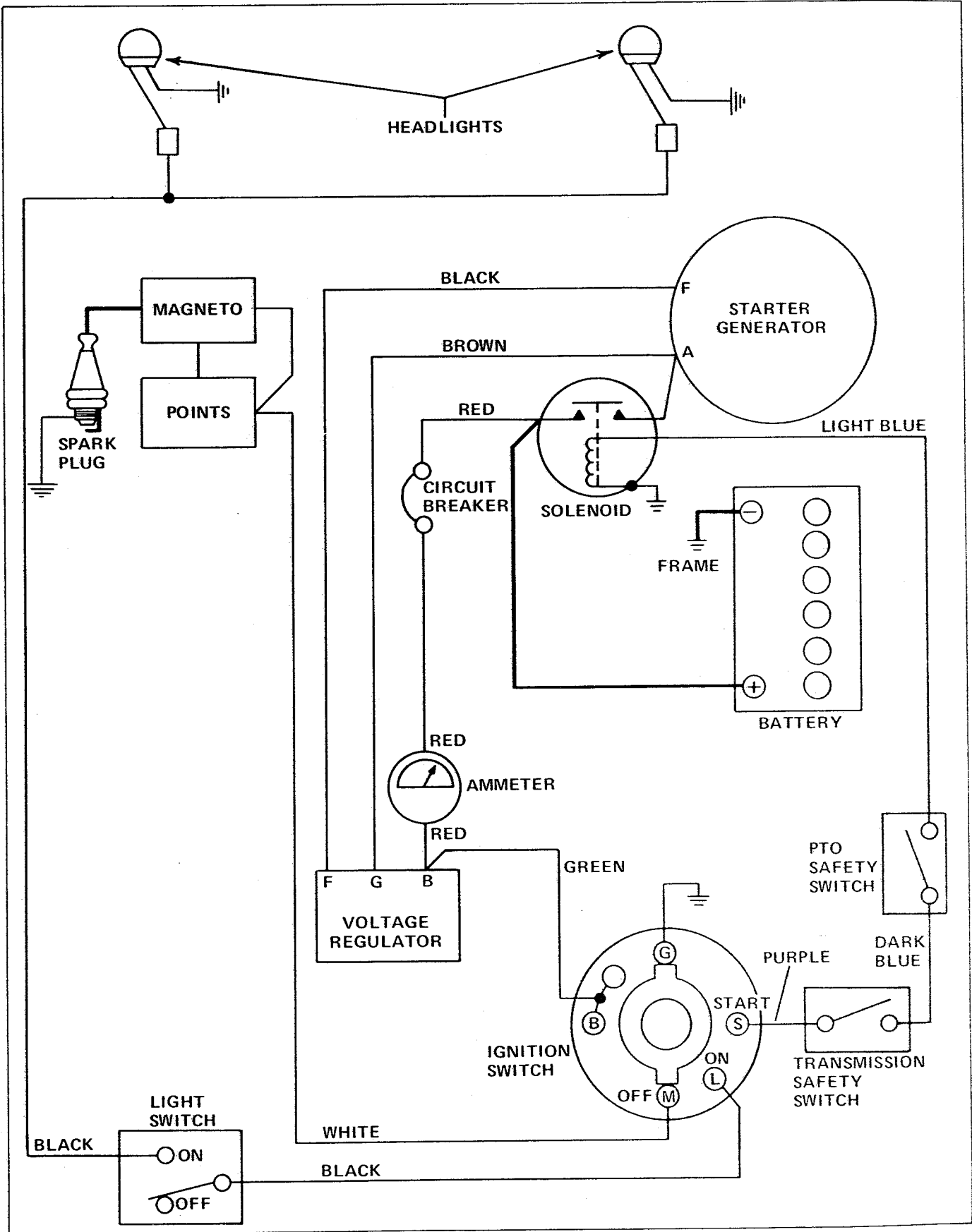

Figure 32. Electrical Schematic

Specifications

ENGINE	MAKE: BRIGGS AND STRATTON	7016 MODEL NO: 326431 HORSEPOWER: 16 CYCLES: 4 CYLINDERS: 1 BORE: 3-9/16 Inches STROKE: 3-1/4 Inches DISPLACEMENT: 32.4 Cu. In. CRANKSHAFT: Horizontal	7010 MODEL NO: 243431 HORSEPOWER: 10 CYCLES: 4 CYLINDERS: 1 BORE: 3-1/16 Inches STROKE: 3-1/4 Inches DISPLACEMENT: 23.94 Cu. In. CRANKSHAFT: Horizontal
	Electrical System	Belt Driven Generator, Regulated DC Output	
		12 Volt – 45 Amp. Hr. Automotive Battery	
		Key Ignition Switch	
		Ammeter on Instrument Panel	
	Ignition	TYPE: Flywheel Magneto w/Key Switch	
		Dust Proof Breaker Enclosure	
	Governor	TYPE: Adjustable, Mechanical, Running in Oil	
		RANGE: 1200 to 3600 R.P.M.	
	Air Cleaner	Dual Dry and Oiled Foam Elements.	
		ELEMENTS: Reusable Polyurethane Foam and Paper	
	Crankcase	BREATHER: Ventilated through Carburetor	
		LUBRICATION: Gear Impeller System	
		OIL CAPACITY: 2 Quarts	
Fuel Tank	MATERIAL: Non-Corrosive, Molded Synthetic Material		
	Fuel Level Guage Built into Filler Gap		
	CAPACITY: 3 Gallons		
Muffler	Quiet Compact, Low Back Pressure		
TRANSMISSION	Type	Sliding Spur Gear with Differential	
		With Dual Range V-Belt Drive	
	Material	Hardened and Ground Gears and Shafts	
		Rolling Contact Bearings	
	Lubrication	SAE 90 OIL CAPACITY: 2.25 Quarts	
	Speeds	6 Forward, 2 Reverse	
	Ground Speeds at 3600 RPM	HI RANGE	LOW: 1.6 MPH
SECOND: 3.7 MPH			SECOND: 1.7 MPH
REVERSE		THIRD: 6.1 MPH	THIRD: 2.8 MPH
		REVERSE: 3.2 MPH	REVERSE: 1.5 MPH
Differential	Planetary Spur Gear -Controlled Traction		
CHASSIS	Frame	Channel, Electrically Welded, Heavy Guage Steel	
		POWER TAKE-OFF POINTS: Front, Center and Rear	
		ENGINE MOUNTING: Above Front Axle	
		PIVOT POINT LOCATION: At Front Axle	
	Rear Wheels	PNEUMATIC INFLATION PRESSURE: 6 to 8 P.S.I.	
		7010 TIRE SIZE: 23 x 8.50 - 12 Terra-Tread (Tubeless)	
7016 TIRE SIZE: 23 x 10.50 - 12 Terra-Tread (Tubeless)			

CHASSIS (cont'd).	Front Wheels	PNEUMATIC INFLATION PRESSURE: 12 to 15 P.S. I.	
		7010 TIRE SIZE: 4.80 x 4.00-8	
		7016 TIRE SIZE: 16 x 6.50-8	
	Accessibility	Hood Tips Forward	
		Seat Deck Tips Rearward	
	Seat	TYPE: Molded – Foam	
		COVER: Black Vinyl	
POSITIONS: 4			
Turning Radius	INSIDE REAR TIRE: 30.5 Inches		
CONTROLS	Steering	Full Circle Steering Wheel	
		SYSTEM; 4.14 to 1 Ratio, Gear and Sector	
	Clutch-Brake Pedal	LOCATION: Right Front	
		CLUTCH: Soft Action, Touch-O-Matic V-Belt	
		BRAKE: External Band Type	
	Location	Parking Brake Lock Standard Equipment	
		IMPLEMENT LIFT LEVER: Left Side	
		POWER TAKE-OFF CLUTCH LEVER: Left Side	
		SPEED RANGE LEVER: Right Side	
		Ignition Key Switch	On Instrument Panel
		Light Switch	
		Throttle Lever	
	Choke Control		
Ammeter			
PARKING BRAKE LOCK: Lower Left of Seat			
DIMENSIONS	Overall Length	67 Inches	
	Overall Width	37.5 Inches	
	Height	TO TOP OF ENGINE COVER: 35.5 Inches	
		TO TOP OF STEERING WHEEL: 39.25 Inches	
	Wheel Base	48.1 Inches	
	Approximate Weight	627 Pounds	
TUNE-UP DATA	Spark Plug Type (* indicates type for areas subject to radio noise limitations.	AC: CS-45 (short) or GC-46 (long)	
		Autolite: A7N (short) or A71 (long) or AR7N (*)	
		Champion: CJ-8 (short) or J-8 (long) or RCJ-8 (*)	
	Spark Plug Gap	.030 Inch	
	Ignition Point Gap	.020 Inch	

SPECIFICATIONS SUBJECT TO CHANGE WITHOUT NOTICE

Accessories

There are many optional accessories available for your Simplicity tractor through your Simplicity dealer. They will make your tractor perform better or easier to operate when using various attachments. See your Simplicity dealer if you wish to purchase any of the following:

WHEEL WEIGHTS – FRONT, REAR

REAR LIGHT KIT

POWER LIFT KIT

DUAL LIFT LEVER

REAR LIFT KIT

ENGINE WINTERIZING KIT

TIRE CHAINS

HOURLY METER

REAR BALL HITCH

HUB CAPS

Attachments

To make your Simplicity tractor most useful to you, a complete line of attachments is available through your Simplicity dealer. Contact him if you wish to purchase any of the following:

42" & 48" ROTARY MOWERS

P.T.O. VACUUM COLLECTOR

42" & 48" VACUUM COLLECTOR ADAPTERS

ROVING NOZZLE FOR VACUUM COLLECTOR

DUMP CART

DUMP CART COVER

46" SICKLE BAR MOWER

ONE-POINT HITCH

36" & 42" ROTARY SNOW THROWERS

42" & 46" SNOW PLOW AND DOZER BLADES

SNOW CAB

36" ROTARY TILLER

38" HEAVY DUTY TILLER











42" GRADER BLADE

SPRING TOOTH HARROW

CULTIVATOR

10" MOLDBOARD PLOW

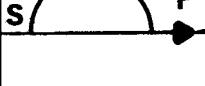
540 RPM PTO

Attachment	Engine Speed Control	Speed Range	Trans. Gear	Approx. Ground Speed (MPH)	Required Accessories and Options	Recommended Accessories and Options
Transporting Tractor		HI	3	3-6		
42" or 48" Rotary Mower (Smooth terrain - normal grass)		LO	3	3-4		2 Rear wheel weights when mowing slopes 20-35% mowing slopes greater than 35% not recommended.
		HI	2			
42" or 48" Rotary Mower (Rough terrain - heavy or wet grass)		LO	2	2-3		2 Rear wheel weights when mowing slopes 20-35% mowing slopes greater than 35% not recommended.
		HI	1			
46" Sickle Bar		LO	2	2-4		2 Rear wheel weights when mowing slopes 20-35% mowing slopes greater than 35% not recommended.
		HI	2			
36" or 42" Snow Thrower (Light Snow)		LO	3	3-4		Power lift kit. Tire chains. 4 Rear wheel weights. 2 Front wheel weights.
		HI	2			
36" or 42" Snow Thrower (Heavy or wet snow)		LO	1	1-1.5		Power lift kit. Tire chains. 4 Rear wheel weights. 2 Front wheel weights.
		HI	1			
42" or 46" Snow Plow and Dozer Blade		LO	3	3-4		Tire chains. 4 Rear wheel weights. 2 Front wheel weights. Power lift kit.
		HI	2			
42" Grader Blade		LO	3	3-4		4 Rear wheel weights.
		HI	2			
36" Rotary Tiller		LO	1	1-1.5	Rear lift kit.	4 Rear wheel weights. 2 Front wheel weights. Power lift kit.
		HI	1			
10" Mounted Plow		LO	1	1-1.5	Rear lift kit.	4 Rear wheel weights. 2 Front wheel weights. Power lift kit.
		HI	1			
Cultivator		LO	2	2-4	Rear lift kit.	4 Rear wheel weights. 2 Front wheel weights. Power lift Kit.
		HI	2			
Spring Tooth Harrow		LO	2	2-4	Rear lift kit.	4 Rear wheel weights. 2 Front wheel weights. Power lift kit.
		HI	2			

REFER TO YOUR ATTACHMENT OWNERS MANUALS FOR ADDITIONAL INFORMATION.

PARTS MANUALS AVAILABLE FOR 7010 AND 7016

You can order a parts manual for your tractor and for your attachments. Check the appropriate box below for the parts manual(s) you want, enclose the form with a check or money order made out to SIMPLICITY in an envelope, and send them to:

Simplicity Manufacturing Co.
500 N. Spring Street
Port Washington, WI 53074

Parts manual TP-384 contains the 7010 and 7016 Tractors, and 48" mower and 42" mower and hitch.

Parts manual TP-219 contains: 36" and 42" Snow Thrower
42" and 46" Snow Plow and Dozer Blade and Hitches
36" Tiller
38" Tiller
42" Grader Blade
10" Moldboard Plow
Vacuum Collector and adapters
Dump Cart and Cover
and all available accessories.

CUT HERE

- I would like a parts manual (TP-384) for my 7000 Series tractor and mower. I am enclosing a check or money order for \$2.00.
- I would like a parts manual (TP-219) for my 7000 Series attachments and accessories. I am enclosing a check or money order for \$2.00.
- I would like parts manuals for both the 7000 Series tractors and the 7000 Series attachments and accessories. I am enclosing a check or money order for \$4.00.

NAME _____ Tractor No. _____

STREET OR RFD _____

CITY _____ STATE _____ ZIP _____

(Allow Two or Three Weeks For Delivery)

Send this form with your check or money order to:

SIMPLICITY MANUFACTURING CO.
ATTN: CUSTOMER PUBLICATIONS
500 N. SPRING STREET
PORT WASHINGTON, WI 53074