

Print Vendor Instructions

How to use this file Operator's Manuals

- Paper Size:**
- 11x17
 - Body - 50 lbs brilliant white offset or equivalent
 - Cover - on pre-printed two tone "Swash" stock.
- Press:**
- Body - 1 color, 2-sided
 - Cover - 1 color, 1 sided
- Bindery:**
- Saddle stitch, face trim *if too thick for saddle stitch, tape bind
- Covers:**
- FRONT COVER is present at the beginning of the file.
 - BACK COVER is the page immediately after the front cover.
 - The part number for this manual (typically a 172_____ number) is located on the front cover.
 - This file may contain several manuals which differ only by their covers. See the part number at the bottom of the cover page. .
- Body:**
- The body for all manuals is identical regardless of the cover.
 - Odd number pages are always right hand pages, even number pages are always left hand pages.
- General:**
- This instruction sheet is NOT part of the manual and must not be printed.
 - Pages labeled "THIS PAGE INTENSIONALLY BLANK" are placement pages and should NOT be printed.

**THIS PAGE INTENTIONALLY BLANK
(FOR PLACEMENT ONLY - DO NOT PRINT)**



OPERATOR'S MANUAL



Citation Series

21HP Zero-Turn Riders

Mfg. No.	Description
----------	-------------

2690444	Simplicity 21HP Citation Zero-Turn Rider with 48" Mower
---------	---

23HP Zero-Turn Riders

Mfg. No.	Description
----------	-------------

2690445	Simplicity 23HP Citation Zero-Turn Rider with 52" Mower
---------	---

5100324

Revision 02

Rev. Date: 4/2006

TP 100-7250-02-CI-S



MANUFACTURING, INC.
500 N Spring Street / PO Box 997
Port Washington, WI 53074-0997

www.simplicitymfg.com

© Copyright 2006, Simplicity Manufacturing, Inc.
All Rights Reserved. Printed in USA.

Table of Contents

Safety Rules & Information	2	Troubleshooting, Adjustments & Service	23
Identification Numbers	7	Troubleshooting the Rider	23
Safety Decals	8	Troubleshooting the Mower	24
Safety Interlock System.....	9	Seat Adjustment.....	25
Features & Controls	10	Ground Speed Control Lever Adjustment.....	25
Control Functions.....	10	Speed Balancing Adjustment.....	25
Operation	12	Parking Brake Adjustment	26
General Operating Safety	12	Battery Charging.....	26
Checks Before Starting.....	12	Rear Suspension Adjustment	27
Starting the Engine	13	PTO Clutch Adjustment	28
Stopping the Rider	13	Blade Brake Check.....	28
Mowing.....	13	Return to Neutral Adjustment	29
Pushing the Rider by Hand.....	13	Neutral Adjustment	29
Zero Turn Driving Practice	14	Mowing Height Adjustment	30
Raise & Lower the Roll Bar	16	Foot Pedal Adjustment.....	30
Attaching a Trailer	17	Deck Leveling Adjustment.....	31
Storage.....	17	Hydraulic Pump Drive Belt Replacement.....	32
Regular Maintenance	18	Mower Belt Replacement.....	33
Maintenance Schedule	18	Specifications	34
Checking Tire Pressures.....	19	Lawn Care & Mowing Information	LC-1
Checking/Adding Fuel.....	19		
Fuel Filter	19		
Oil & Filter Change	19		
Lubrication	20		
Check Hydraulic Oil Level.....	21		
Hydraulic Oil Filter Change.....	21		
Battery Maintenance.....	21		
Cleaning the Battery and Cables.....	21		
Servicing the Mower Blades	22		

NOTE: In this manual, “left” and “right” are referred to as seen from the operating position.

WARNING

You must read, understand and comply with all safety and operating instructions in this manual before attempting to set-up and operate your machine.

Failure to comply with all safety and operating instructions can result in loss of machine control, serious personal injury to you and / or bystanders, and risk of equipment and property damage. The triangle  in the text signifies important cautions or warnings which must be followed.

WARNING

Engine exhaust from this product contains chemicals known, in certain quantities, to cause cancer, birth defects, or other reproductive harm.

Safety Rules and Information



Read these safety rules and follow them closely. Failure to obey these rules could result in loss of control of unit, severe personal injury or death to you, or bystanders, or damage to property or equipment.

This mowing deck is capable of amputating hands and feet and throwing objects.

The triangle  in text signifies important cautions or warnings which must be followed.

GENERAL OPERATION

1. Read, understand, and follow all instructions in the manual and on the unit before starting.
2. Do not put hands or feet near rotating parts or under the machine. Keep clear of the discharge opening at all times.
3. Only allow responsible adults, who are familiar with the instructions, to operate the unit (local regulations can restrict operator age).
4. Clear the area of objects such as rocks, toys, wire, etc., which could be picked up and thrown by the blade(s).
5. Be sure the area is clear of other people before mowing. Stop the unit if anyone enters the area.
6. Never carry passengers.
7. Do not mow in reverse unless absolutely necessary. Always look down and behind before and while travelling in reverse.
8. Never direct discharge material toward anyone. Avoid discharging material against a wall or obstruction. Material may ricochet back toward the operator. Stop the blade(s) when crossing gravel surfaces.
9. Do not operate the machine without the entire grass catcher, discharge guard (deflector), or other safety devices in place and operational.
10. Slow down before turning.
11. Never leave a running unit unattended. Always disengage the blades (PTO), set parking brake, stop engine, and remove keys before dismounting.
12. Disengage blades (PTO) when not mowing. Shut off engine and wait for all parts to come to a complete stop before cleaning the machine, removing the grass catcher, or unclogging the discharge guard.
13. Operate the machine only in daylight or good artificial light.
14. Do not operate the unit while under the influence of alcohol or drugs.
15. Watch for traffic when operating near or crossing roadways.
16. Use extra care when loading or unloading the unit into a trailer or truck.
17. Always wear eye protection when operating this unit.
18. Data indicates that operators, age 60 years and above, are involved in a large percentage of power equipment-related injuries. These operators should evaluate their ability to operate the equipment safely enough to protect themselves and others from injury.
19. Follow the manufacturer's recommendations for wheel weights or counterweights.
20. Keep in mind the operator is responsible for accidents occurring to other people or property.
21. All drivers should seek and obtain professional and practical instruction.
22. Always wear substantial footwear and trousers. Never operate when barefoot or wearing sandals.
23. Before using, always visually check that the blades and blade hardware are present, intact, and secure. Replace worn or damaged parts.
24. Disengage attachments before: refueling, removing an attachment, making adjustments (unless the adjustment can be made from the operator's position).
25. When the machine is parked, stored, or left unattended, lower the cutting means unless a positive mechanical lock is used.
26. Before leaving the operator's position for any reason, engage the parking brake (if equipped), disengage the blades (PTO), stop the engine, and remove the key.
27. To reduce fire hazard, keep the unit free of grass, leaves, & excess oil. Do not stop or park over dry leaves, grass, or combustible materials.
28. It is a violation of California Public Resource Code Section 4442 to use or operate the engine on or near any forest-covered, brush-covered, or grass-covered land unless the exhaust system is equipped with a spark arrester meeting any applicable local or state laws. Other states or federal areas may have similar laws.
29. OSHA regulations may require the use of hearing protection when exposed to sound levels greater than 85 dBA for an 8 hour time period.

CAUTION



This machine produces sound levels in excess of 85 dBA at the operator's ear and can cause hearing loss through extended periods of exposure.

Wear hearing protection when operating this machine.

TRANSPORTING AND STORAGE

1. When transporting the unit on an open trailer, make sure it is facing forward, in the direction of travel. If the unit is facing backwards, wind lift could damage the unit.
2. Always observe safe refueling and fuel handling practices when refueling the unit after transportation or storage.
3. Never store the unit (with fuel) in an enclosed poorly ventilated structure. Fuel vapors can travel to an ignition source (such as a furnace, water heater, etc.) and cause an explosion. Fuel vapor is also toxic to humans and animals.
4. Always follow the engine manual instructions for storage preparations before storing the unit for both short and long term periods.
5. Always follow the engine manual instructions for proper start-up procedures when returning the unit to service.
6. Never store the unit or fuel container inside where there is an open flame or pilot light, such as in a water heater. Allow unit to cool before storing.

SLOPE OPERATION

Slopes are a major factor related to loss-of-control and tip-over accidents, which can result in severe injury or death. Operation on all slopes requires extra caution. If you cannot back up the slope or if you feel uneasy on it, do not operate on it.

Control of a walk-behind or ride-on machine sliding on a slope will not be regained by the application of the brake. The main reasons for loss of control are: insufficient tire grip on the ground, speed too fast, inadequate braking, the type of machine is unsuitable for its task, lack of awareness of the ground conditions, incorrect hitching and load distribution.

1. Mow across slopes, not up and down.
2. Watch for holes, ruts, or bumps. Uneven terrain could overturn the unit. Tall grass can hide obstacles.
3. Choose a slow speed so that you will not have to stop or change speeds while on the slope.
4. Do not mow on wet grass. Tires may lose traction.
5. Avoid starting, stopping, or turning on a slope. If tires lose traction (i.e. machine stops forward motion on a slope), disengage the blade(s) (PTO) and drive slow off the slope.
6. Keep all movement on slopes slow and gradual. Do not make sudden changes in speed or direction, which could cause the machine to rollover.
7. Use extra care while operating machines with grass catchers or other attachments; they can affect the stability of the unit. Do not use on steep slopes.
8. Do not try to stabilize the machine by putting your foot on the ground (ride-on units).
9. Do not mow near drop-offs, ditches, or embankments. The mower could suddenly turn over if a wheel is over the edge of a cliff or ditch, or if an edge caves in.
10. Do not use grass catchers on steep slopes.
11. Do not mow slopes if you cannot back up them.
12. See your authorized dealer/retailer for recommendations of wheel weights or counterweights to improve stability.
13. Remove obstacles such as rocks, tree limbs, etc.
14. Use slow speed. Tires may lose traction on slopes even though the brakes are functioning properly.
15. Do not turn on slopes unless necessary, and then, turn slowly and gradually uphill, if possible. Never mow down slopes.

TOWED EQUIPMENT (RIDE-ON UNITS)

1. Tow only with a machine that has a hitch designed for towing. Do not attach towed equipment except at the hitch point.
2. Follow the manufacturer's recommendations for weight limit for towed equipment and towing on slopes. See attaching a trailer under OPERATION.
3. Never allow children or others in or on towed equipment.
4. On slopes, the weight of the towed equipment may cause loss of traction and loss of control.
5. Travel slowly and allow extra distance to stop.
6. Do not shift to neutral and coast down hill.

WARNING

Never operate on slopes greater than 17.6 percent (10°) which is a rise of 3-1/2 feet (106 cm) vertically in 20 feet (607 cm) horizontally.

Select slow ground speed before driving onto slope. Use extra caution when operating on slopes with rear-mounted grass catchers.

Mow across the face of slopes, not up and down, use caution when changing directions and DO NOT START OR STOP ON SLOPE.

CHILDREN

Tragic accidents can occur if the operator is not alert to the presence of children. Children are often attracted to the unit and the mowing activity. Never assume that children will remain where you last saw them.

1. Keep children out of the mowing area and under the watchful care of another responsible adult.
2. Be alert and turn unit off if children enter the area.
3. Before and during reverse operation, look behind and down for small children.
4. Never carry children, even with the blade(s) off. They may fall off and be seriously injured or interfere with safe unit operation. Children who have been given rides in the past may suddenly appear in the mowing area for another ride and be run over or backed over by the machine.
5. Never allow children to operate the unit.
6. Use extra care when approaching blind corners, shrubs, trees, or other objects that may obscure vision.

EMISSIONS

1. Engine exhaust from this product contains chemicals known, in certain quantities, to cause cancer, birth defects, or other reproductive harm.
2. Look for the relevant Emissions Durability Period and Air Index information on the engine emissions label.

IGNITION SYSTEM

1. This spark ignition system complies with Canadian ICES-002.

Safety Rules and Information

SERVICE AND MAINTENANCE

Safe Handling of Gasoline

1. Extinguish all cigarettes, cigars, pipes, and other sources of ignition.
2. Use only approved gasoline containers.
3. Never remove the gas cap or add fuel with the engine running. Allow the engine to cool before refueling.
4. Never fuel the machine indoors.
5. Never store the machine or fuel container where there is an open flame, spark, or pilot light such as near a water heater or other appliance.
6. Never fill containers inside a vehicle or on a truck bed with a plastic bed liner. Always place containers on the ground away from your vehicle before filling.
7. Remove gas-powered equipment from the truck or trailer and refuel it on the ground. If this is not possible, then refuel such equipment on a trailer with a portable container, rather than from a gasoline dispenser nozzle.
8. Keep nozzle in contact with the rim of the fuel tank or container opening at all times until fueling is complete. Do not use a nozzle lock-open device.
9. If fuel is spilled on clothing, change clothing immediately.
10. Never over-fill the fuel tank. Replace gas cap and tighten securely.
11. Use extra care in handling gasoline and other fuels. They are flammable and vapors are explosive.
12. If fuel is spilled, do not attempt to start the engine but move the machine away from the area of spillage and avoid creating any source of ignition until fuel vapors have dissipated.
13. Replace all fuel tank caps and fuel container caps securely.

Service & Maintenance

1. Never run the unit in an enclosed area where carbon monoxide fumes may collect.
2. Keep nuts and bolts, especially blade attachment bolts, tight and keep equipment in good condition.
3. Never tamper with safety devices. Check their proper operation regularly and make necessary repairs if they are not functioning properly.
4. Keep unit free of grass, leaves, or other debris build-up. Clean up oil or fuel spillage and remove any fuel-soaked debris. Allow machine to cool before storage.
5. If you strike an object, stop and inspect the machine. Repair, if necessary, before restarting.
6. Never make adjustments or repairs with the engine running.
7. Check grass catcher components and the discharge guard frequently and replace with manufacturer's recommended parts, when necessary.
8. Mower blades are sharp. Wrap the blade or wear gloves, and use extra caution when servicing them.
9. Check brake operation frequently. Adjust and service as required.
10. Maintain or replace safety and instructions labels, as necessary.
11. Do not remove the fuel filter when the engine is hot as spilled gasoline may ignite. Do not spread fuel line clamps further than necessary. Ensure clamps grip hoses firmly over the filter after installation.

12. Do not use gasoline containing METHANOL, gasohol containing more than 10% ETHANOL, gasoline additives, or white gas because engine/fuel system damage could result.
13. If the fuel tank must be drained, it should be drained outdoors.
14. Replace faulty silencers/mufflers.
15. Maintain or replace safety and instruction labels as necessary.
16. Use only factory authorized replacement parts when making repairs.
17. Always comply with factory specifications on all settings and adjustments.
18. Only authorized service locations should be utilized for major service and repair requirements.
19. Never attempt to make major repairs on this unit unless you have been properly trained. Improper service procedures can result in hazardous operation, equipment damage and voiding of manufacturer's warranty.
20. On multiple blade mowers, take care as rotating one blade can cause other blades to rotate.
21. Do not change engine governor settings or over-speed the engine. Operating the engine at excessive speed can increase the hazard of personal injury.
22. Disengage drive attachments, stop the engine, remove the key, and disconnect the spark plug wire(s) before: clearing attachment blockages and chutes, performing service work, striking an object, or if the unit vibrates abnormally. After striking an object, inspect the machine for damage and make repairs before restarting and operating the equipment.
23. Never place hands near the moving parts, such as a hydro pump cooling fan, when the tractor is running. (Hydro pump cooling fans are typically located on top of the transaxle).
24. Units with hydraulic pumps, hoses, or motors: **WARNING:** Hydraulic fluid escaping under pressure may have sufficient force to penetrate skin and cause serious injury. If foreign fluid is injected into the skin it must be surgically removed within a few hours by a doctor familiar with this form of injury or gangrene may result. Keep body and hands away from pin holes or nozzles that eject hydraulic fluid under high pressure. Use paper or cardboard, and not hands, to search for leaks. Make sure all hydraulic fluid connections are tight and all hydraulic hoses and lines are in good condition before applying pressure to the system. If leaks occur, have the unit serviced immediately by your authorized dealer.
25. **WARNING:** Stored energy device. Improper release of springs can result in serious personal injury. Springs should be removed by an authorized technician.
26. Models equipped with an engine radiator: **WARNING:** Stored energy device. To prevent serious bodily injury from hot coolant or steam blow-out, never attempt to remove the radiator cap while the engine is running. Stop the engine and wait until it is cool. Even then, use extreme care when removing the cap.

ROLL BAR INSTRUCTIONS

For models equipped with factory-installed Roll Over Protection System (ROPS).

WARNING

In order to avoid serious injury or death from roll over, it is important to follow the warnings listed below.

OPERATIONAL WARNINGS

- Always use the seat belt when the roll bar is in the raised position.
- Never use the seat belt when the roll bar is in the down position.
- Remember there is no roll over protection when the roll bar is in the down position so it is very important to always keep the roll bar in the raised position whenever possible.
- Lower the roll bar to the down position only when it is absolutely necessary.
- Check for overhead clearances before driving under any objects. Do not allow roll bar to contact low overhanging obstacles such as tree branches and guide wires.
- Never remove the roll bar from the vehicle.
- Do not exceed the machine weight rating of the roll bar.
- Read and follow all of the instructions shown below regarding the inspection and maintenance of the roll bar structure and the seat belt.

WARNING

Failure to properly inspect and maintain the ROLL BAR protective structure can cause serious injury or death.

INSPECTION OF THE ROLL BAR PROTECTIVE STRUCTURE

A ROLL BAR, like any other safety device, needs to be periodically inspected to verify that the integrity of the device has not been compromised through normal machine use, misuse, age degradation, modifications, or a roll over.

To maintain operator roll over protection and roll bar effectiveness:

- If a ROLL BAR becomes damaged for any reason, such as a collision, roll over or impact, the ROLL BAR must be replaced. Small undetectable cracks can reduce the effectiveness of the ROLL BAR. Never weld, straighten, or repair the ROLL BAR.
- Never alter the ROLL BAR by welding anything to it or by drilling additional holes.

- **BEFORE FIRST TIME USE** - Inspect the ROLL BAR structure and mounting hardware for:
 - 1) Check to make sure the machine GVW (Gross Vehicle Weight), including attachments, restrained payload, fuel and operator, is not in excess of the maximum weight specified on the ROLL BAR label.
 - 2) Make sure there isn't any missing, damaged, or loose mounting hardware.
 - 3) Make sure the ROLL BAR has been correctly and completely installed.
- **EVERY 100 HOURS** - Inspect the ROLL BAR structure and mounting hardware for:
 - 1) Any cracks in the structure (structural members and/or welds).
 - 2) Significant corrosion on any part of the ROLL BAR structure or hardware.
 - 3) Missing, damaged, or loose mounting hardware.
 - 4) Mounting hardware that is of a grade lesser than specified.
 - 5) Machine GVW (Gross Vehicle Weight), including attachments, restrained payload, fuel and operator, in excess of the maximum weight specified on the ROLL BAR label.
 - 6) Any modifications that have been made, such as unauthorized welds and holes.
 - 7) Any permanent deformation or twisting of the ROLL BAR structure.
 - 8) That the ROLL BAR label is still in place and is readable.
 - 9) That the ROLL BAR on-product warning labels are still on the ROLL BAR and are readable.
- If there is any doubt as to the condition of the ROLL BAR, remove the machine from service and contact your dealer for assistance.

Safety Rules & Information

! WARNING

Failure to properly inspect and maintain the seat belt can cause serious injury or death.

INSPECTION AND MAINTENANCE OF THE ROLL BAR SEAT BELT

- The seat belt like the ROLL BAR, needs to be periodically inspected to verify that the integrity has not been compromised through normal machine use, misuse, age degradation, modifications, or a roll over. If the seat belt does not pass all of the following tests, it should be replaced.
- **BEFORE EACH USE** – Conduct the following inspections/maintenance of the seat belt and retraction mechanism:
 - 1) Check for dirt or debris in the retraction mechanism. If dirt or debris is found, it should be removed.
 - 2) Check to make sure the retraction mechanism retracts easily and completely.
 - 3) Check for damage to any part of the seat belt such as nicks, cuts, loose stitching, or fraying.
 - 4) Check that the buckle and latch operate properly and that the latch plate is not excessively worn, deformed, or the buckle is damaged or cracked. The seat belt should latch and release easily.

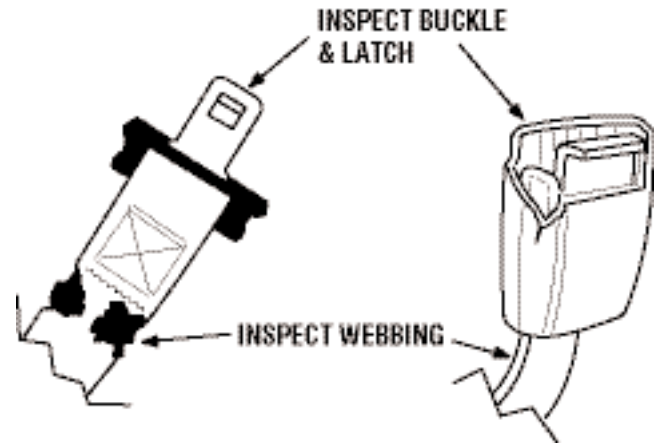

Identification Numbers



North American /
CE Models

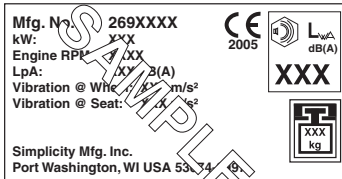

CE Models
(Only)

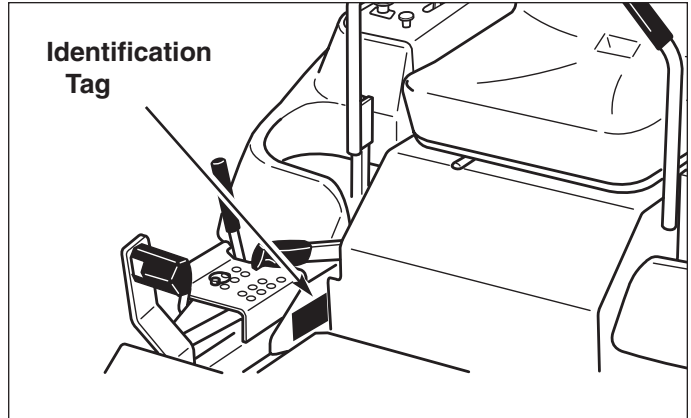

When contacting your authorized dealer for replacement parts, service, or information you **MUST** have these numbers.

Record your part number, serial number and engine serial numbers in the space provided for easy access. These numbers can be found in the locations shown.

NOTE: For location of engine identification numbers, refer to the engine owner's manual.

PRODUCT REFERENCE DATA	
Unit Part Number	Unit SERIAL Number
Mower Deck Part Number	Mower Deck SERIAL Number
Dealer Name	Date Purchased
ENGINE REFERENCE DATA	
Engine Make	Engine Model
Engine Type/Spec.	Engine Code/Serial Number

CE IDENTIFICATION TAG MARKINGS

- A. Manufacturer's Identification Number
- B. Power Rating in Kilowatts
- C. Maximum Engine Speed in Rotations per Minute
- D. Sound Pressure at Operator's Position in Decibels **
- E. Manufacturer's Address
- F. Year of Manufacture
- G. CE Compliance Logo
- H. Mass of Unit in Kilograms
- I. Sound Power in Decibels ***
- J. Vibration at the Steering Wheel *
- K. Vibration at the Seat *

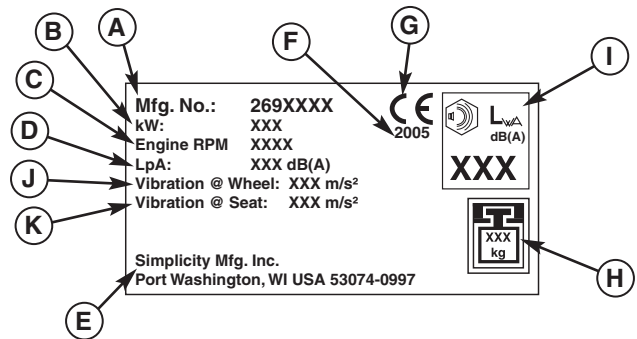

This unit complies with European Harmonized Lawn Mower Standard EN 836, European Machinery Directive 98/37/EC, and European EMC Directive 89/336/EC

* Tested according to EN 836:1997/A2:2001, EN 1032:1996, EN 1033:1995

** Tested according to EN836:1997/A2:2001

*** Tested according to 2000/14/EC

*CE Models:
Place copy of
Identification Tag here.*

Safety Decals

SAFETY DECALS

This unit has been designed and manufactured to provide you with the safety and reliability you would expect from an industry leader in outdoor power equipment manufacturing.

Although reading this manual and the safety instructions it contains will provide you with the necessary basic knowledge to operate this equipment safely and effectively, we have placed several safety labels on the unit to remind you of this important information while you are operating your unit.

<p>▲ WARNING</p> <ul style="list-style-type: none"> Never operate the unit on a slope that is too steep for the unit. Keep safety devices (guards, shields & handles) in place and working. Remove objects that can be thrown by the blade. Do NOT mow when children or others are nearby. NEVER carry children, even with blades off. Look down and behind - before and while backing. Avoid sudden turns. Do not cross slopes, NOT up and down. If machine stops forward motion on a slope, stop the blades and drive away off the slope. If you back blades and engine are stopped before backing turn or feet near blades. When backing machine, shut off engine, remove key, and set parking brake. Do NOT operate the machine unless you are trained. Operating on slopes can be dangerous. 	<p>OPERATING ON STEEP SLOPES CAN CAUSE SLIPPING AND LOSS OF STEERING CONTROL AND ROLL-OVER.</p> <ul style="list-style-type: none"> Do NOT operate on a slope that is too steep for the unit. Reduce speed and use extreme caution on slopes. Avoid sudden turns on steep slopes. Do NOT operate on slopes over 10°. <p>AMPUTATION HAZARD</p> <p>To avoid injury to children, stop mower when children are near. Do not allow children, look behind when backing. Never carry children, especially children.</p> <p>WHEELS DROPPING OVER EDGES, DITCHES OR EMBANKMENTS CAN CAUSE ROLL-OVER, WHICH MAY RESULT IN SERIOUS INJURY, DEATH OR DROWNING.</p> <p>Do NOT operate near drop-offs or near water.</p>	<p>▲ DANGER</p> <p>OPERATING ON WET OR SLIPPERY SLOPES CAN CAUSE SLIPPING AND LOSS OF STEERING AND CONTROL.</p> <ul style="list-style-type: none"> Do NOT operate on any slopes when wet or slippery. <p>AVOID FIRE HAZARD</p> <ul style="list-style-type: none"> Keep cut free of grass, leaves and excess oil. Do NOT add fuel while engine is hot or running. STOP engine and allow to cool for 5 minutes prior to adding fuel. Do NOT add fuel indoors, in an enclosed trailer, garage or other enclosed space. Clear up fuel spill. Do NOT smoke while operating this machine. <p>AVOID CARBON MONOXIDE POISONING</p> <p>Do NOT operate the engine in unventilated areas.</p>	<p>▲ DANGER</p> <p>AMPUTATION HAZARD</p> <p>To avoid injury from rotating blades, stay clear of deck edge.</p>
---	--	---	--

Decal - Main
Part No. 5100252

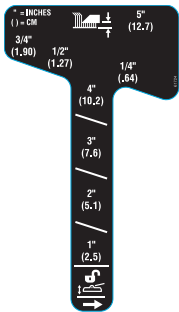

Decal - Height of Cut
Part No. 5061724

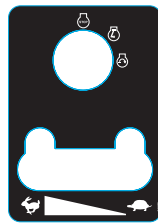

Decal - Ignition / Throttle
Part No. 5061572

Belts & Blades	
Tractor	
Pump Drive Belt	5022314
44" Mower	
Deck Drive Belt	5023496
Mower Blade	5061827
48" Mower	
Deck Drive Belt	5023297
Mower Blade	5020843
52" Mower	
Deck Drive Belt	5023436
Mower Blade	5021227

Decal - Belt & Blade
Part No. 5061790

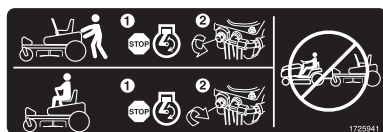

Decal - C-ZT Hydro Release
Part No. 1725941

All DANGER, WARNING, CAUTION and instructional messages on your rider and mower should be carefully read and obeyed. Personal bodily injury can result when these instructions are not followed. The information is for your safety and it is important! The safety decals below are on your rider and mower.

If any of these decals are lost or damaged, replace them at once. See your local dealer for replacements.

These labels are easily applied and will act as a constant visual reminder to you, and others who may use the equipment, to follow the safety instructions necessary for safe, effective operation.

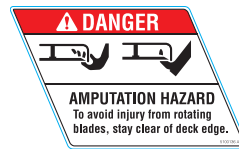

Decal - Danger, Mower
Part No. 5100136



Decal - Danger, Mower
Discharge
Part No. 5100137



Decal -
Warning
Part No.
5100405

Decal - Warning
Part No. 5100403

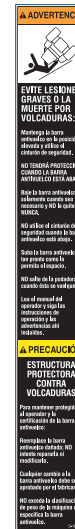

Decal -
Warning (SP)
Part No.
5100406

Decal - Warning (SP)
Part No. 5100404



SAFETY INTERLOCK SYSTEM

This unit is equipped with safety interlock switches. These safety systems are present for your safety, do not attempt to bypass safety switches, and never tamper with safety devices. Check their operation regularly.

Operational SAFETY Checks

Test 1 — Engine should NOT crank if:

- PTO switch is engaged, OR
- Parking brake is not engaged, OR
- Motion control handles are not in the NEUTRAL position.

Test 2 — Engine SHOULD crank if:

- PTO switch is NOT engaged, AND
- Parking brake is engaged, AND
- Motion control handles are locked in the NEUTRAL position.

Test 3 — Engine should SHUT OFF if:

- Operator rises off seat with PTO engaged, OR
- Operator rises off seat with parking brake disengaged.
- Operator moves motion control handles out of their neutral positions before disengaging parking brake.

Test 4 — Blade Brake Check

Mower blades and mower drive belt should come to a complete stop within seven (7) seconds after electric PTO switch is turned off (or operator rises off seat). If mower drive belt does not stop within seven (7) seconds, see your dealer.

NOTE: Once the engine has stopped, PTO switch must be turned off, parking brake must be engaged, and the motion control handles must be locked in the NEUTRAL position after the operator returns to the seat in order to start the engine.

WARNING

If the unit does not pass a safety test, do not operate it. See your authorized dealer. Under no circumstance should you attempt to defeat the purpose of the safety interlock system.

Features & Controls

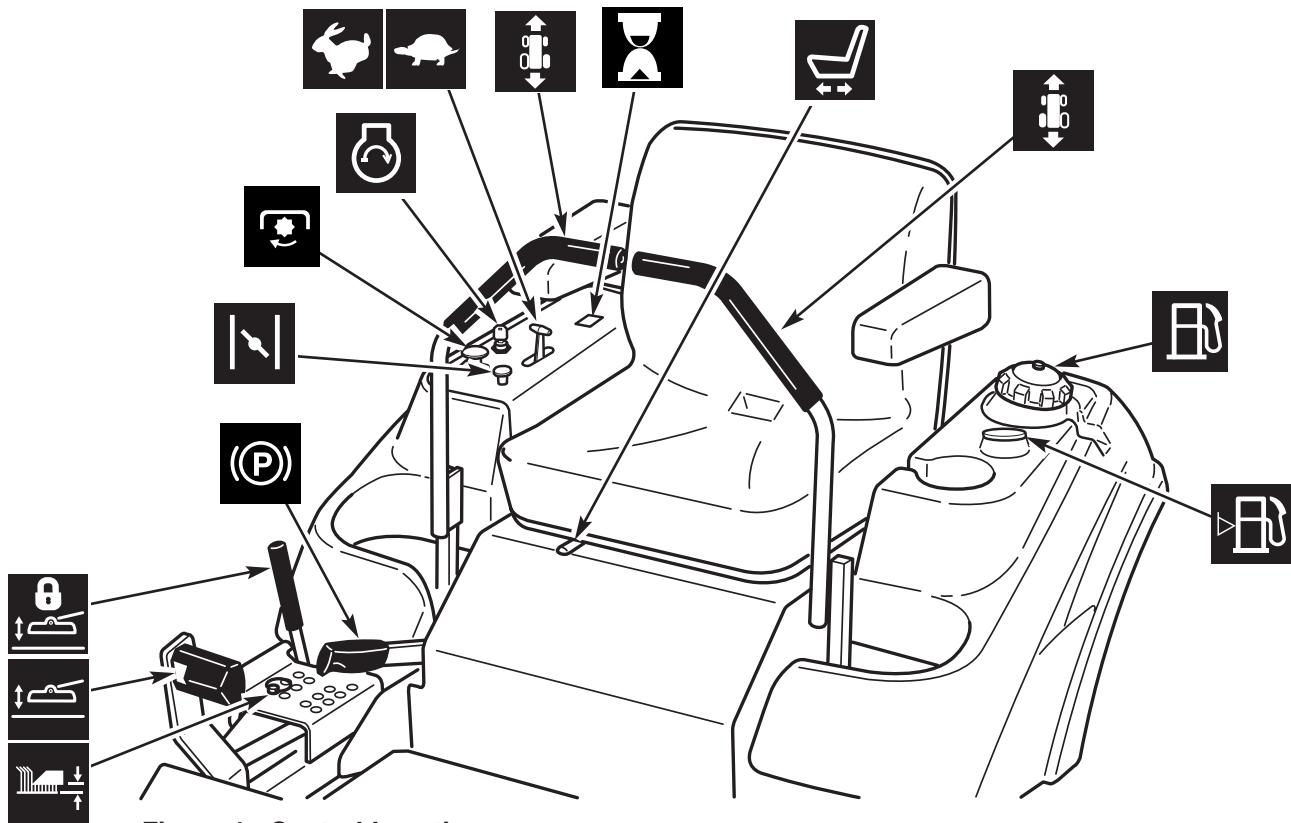

Figure 1. Control Locations

CONTROL FUNCTIONS

The information below briefly describes the function of individual controls. Starting, stopping, driving, and mowing require the combined use of several controls applied in specific sequences. To learn what combination and sequence of controls to use for various tasks see the OPERATION section.

Deck Lift Pedal, Cutting Height Adjustment Pin & Deck Lift Lock Lever

These control the cutting height of the mower deck. Depress the pedal until it locks into the 5" (12,7 cm) position. Place the adjustment pin in the desired cutting height and release the lift lock lever.

Parking Brake

 **DISENGAGE** Releases the parking brake.

 **ENGAGE** Locks the parking brake.

Pull the parking brake lever back to engage the parking brake. Move the lever fully forward to disengage the parking brake. *NOTE: To start the unit the parking brake must be engaged.*

Choke



Close the choke for cold starting. Open the choke once the engine starts. A warm engine may not require choking. Pull the knob UP to close the choke. Push to knob DOWN to open the choke.

PTO (Power Take Off) Switch

The PTO switch engages and disengages the mower. Pull UP on the switch to engage, and push DOWN to disengage.

Ignition Switch

The ignition switch starts and stops the engine, it has three positions:

-  OFF Stops the engine and shuts off the electrical system.
-  RUN Allows the engine to run and powers the electrical system.
-  START Cranks the engine for starting.

NOTE: Never leave the ignition switch in the RUN position with the engine stopped—this drains the battery.

Throttle Control

The throttle controls engine speed. Move the throttle forward to increase engine speed and back to decrease engine speed. Always operate at FULL throttle.

Hour Meter / Maintenance Reminder

Measures the time of the PTO being engaged. The hour meter measures the number of hours the PTO has been engaged. The hour meter will flash an initial oil change indicator at 5 hours, and a lubrication reminder every 50 hours. These reminders display for approximately two hours and will automatically reset themselves.

Note: The hour meter will register the passage of time only when the PTO is engaged. The hour meter has a self contained power source so the total hours are always visible.

Seat Adjustment Lever

The seat can be adjusted forward and back. Move the lever towards the left, position the seat as desired, and release the lever to lock the seat in position.

Ground Speed Levers

These levers control the ground speed of the rider. The left lever controls the left rear drive wheel and the right lever controls the right rear drive wheel.

Moving a lever forward increases the FORWARD speed of the associated wheel, and pulling back on a lever increases the REVERSE speed.

Note: The further a lever is moved away from the neutral position the faster the drive wheel will turn.

See the Operating the Zero Turn Rider section for steering instructions.

Fuel Tank Cap

To remove the cap, turn counterclockwise.

Fuel Level Gauge

Displays the fuel level in the tank.

Operation



GENERAL OPERATING SAFETY

Before first time operation:

- Be sure to read all information in the Safety and Operation sections before attempting to operate this tractor and mower.
- Become familiar with all of the controls and how to stop the unit.
- Drive in an open area without mowing to become accustomed to the unit.

WARNING

Never operate on slopes greater than 17.6 percent (10°) which is a rise of 3-1/2 feet (106 cm) vertically in 20 feet (607 cm) horizontally.

Select slow ground speed before driving onto a slope. Use extra caution when operating on slopes with a rear-mounted grass catcher.

Mow across the face of slopes, not up and down, use caution when changing directions and **DO NOT START OR STOP ON SLOPE.**

WARNING

Never allow passengers to ride on the unit.

Before leaving the operator's position for any reason, engage the parking brake, disengage the PTO, stop the engine and remove the key.

To reduce fire hazard, keep the engine, tractor and mower free of grass, leaves and excess grease. Do not stop or park tractor over dry leaves, grass or combustible materials.

Gasoline is highly flammable and must be handled with care. Never fill the tank when the engine is still hot from recent operation. Do not allow open flame, smoking or matches in the area. Avoid over-filling and wipe up any spills.

CHECKS BEFORE STARTING

- Check that crankcase is filled to full mark on dipstick. See the engine Operator's Manual for instructions and oil recommendations.
- Make sure all nuts, bolts, screws and pins are in place and tight.
- Adjust the seat position, and make certain you can reach all controls from operator's position.
- Fill the fuel tank with fresh fuel. Refer to engine manual for fuel recommendations.

WARNING

Do not load this zero-turn rider on a trailer or truck using two separate ramps. Only use a single ramp that is at least one foot wider than the width of the rear wheels of this rider. This rider has a zero turning radius and the rear wheels could fall off the ramps, or the rider could tip over injuring the operator or bystanders.

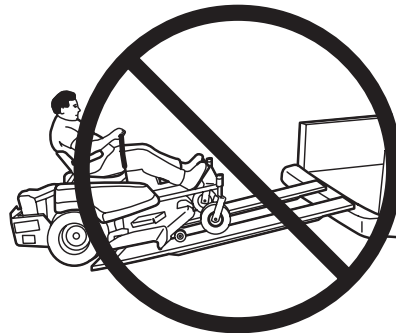

⚠ WARNING

If you do not understand how a specific control functions, or have not yet thoroughly read the **FEATURES & CONTROLS** section, do so now.

Do **NOT** attempt to operate the tractor without first becoming familiar with the location and function of **ALL** controls.

STARTING THE ENGINE

1. While sitting in the operator's seat, engage the parking brake and make sure the PTO switch is disengaged and the motion control handles are locked in the NEUTRAL position.
2. **NOTE: A warm engine may not require choking.**
Set the engine throttle control to FAST throttle position. Then fully close the choke by pulling the knob OUT fully.
3. Insert the key into the ignition switch and turn it to START.
4. After the engine starts, gradually open the choke (push knob down fully).

Warm up the engine by running it for at least a minute before engaging the PTO switch or driving the rider.

5. **After warming the engine, ALWAYS operate the unit at FULL THROTTLE when mowing.**

In the event of an emergency the engine can be stopped by simply turning the ignition switch to STOP. Use this method only in emergency situations. For normal engine shut down follow the procedure given in **STOPPING THE RIDER**.

STOPPING THE RIDER

1. Returning the ground speed control levers to the middle position will stop rider movement. Pivot the levers outward and lock them in NEUTRAL.
2. Disengage the PTO by pushing down on the PTO switch.
3. Engage the parking brake by pulling the handle up until it locks into position.
4. Move the throttle control to mid-throttle position and turn the ignition key to OFF. Remove the key.

MOWING

1. Engage the parking brake. Make sure the PTO switch is disengaged, the motion control levers are locked in the NEUTRAL position and the operator is on the seat.
2. Start the engine (see **STARTING THE ENGINE**).
3. Set the mower cutting height.
4. Set the throttle to FULL.
5. Engage the PTO by pulling up on the PTO switch.
6. Begin mowing. See Section LC for tips on mowing patterns, lawn care, and trouble shooting information.
7. When finished, shut off the PTO.
8. Stop the engine (see **STOPPING THE TRACTOR AND ENGINE**).

PUSHING THE RIDER BY HAND



DO NOT TOW RIDER

Towing the unit will cause hydraulic pump and wheel motor damage. Do not use another vehicle to push or pull this unit.

1. Disengage the PTO, engage the parking brake, turn the ignition OFF, and remove the key.
2. Lift the seat plate to gain access to the hydraulic pumps.
3. To disengage the pumps (free-wheel position), turn the hydraulic release valves (A, Figure 2) located on the pumps COUNTER-CLOCKWISE a maximum of 2 full turns.
4. Disengage the parking brake.
The tractor can now be pushed by hand.
5. After moving the tractor, re-engage the pumps (drive position) by turning the release valves CLOCKWISE and tighten to 80-120 in. lbs. of torque.

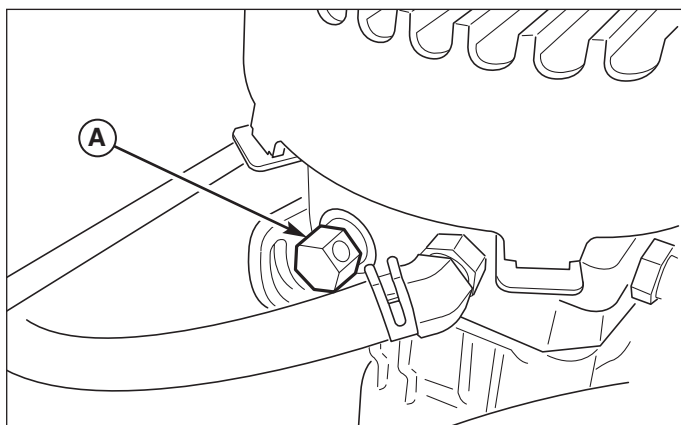

Figure 2. Hydraulic System By-Pass
A. Hydraulic Release Valve
(left-hand pump shown)

Operation

ZERO TURN DRIVING PRACTICE

The lever controls of the Zero Turn rider are responsive, and learning to gain a smooth and efficient control of the rider's forward, reverse, and turning movements will take some practice.

Spending some time going through the maneuvers shown and becoming familiar with how the unit accelerates, travels, and steers — before you begin mowing — is absolutely essential to getting the most out of the Zero Turn rider.

Locate a smooth, flat area of your lawn — one with plenty of room to maneuver. (Clear the area of objects, people and animals before you begin.) Operate the unit at mid-throttle during this practice session (ALWAYS operate at full throttle when mowing), and turn slowly to prevent tire slippage and damage to your lawn.

We suggest you begin with the Smooth Travel procedure to the right, and then advance through the forward, reverse, and turning maneuvers.

You must release the parking brake prior to moving the control levers inward.

Smooth Travel

The lever controls of the Zero Turn rider are responsive .

The BEST method of handling the ground speed control levers is in three steps — as shown in Figure 3.

FIRST place your hands onto the levers as shown.

SECOND, to go forward gradually push the levers forward with your palms.

THIRD, to speed up move the levers farther forward. To slow down smoothly, slowly move the levers toward neutral.

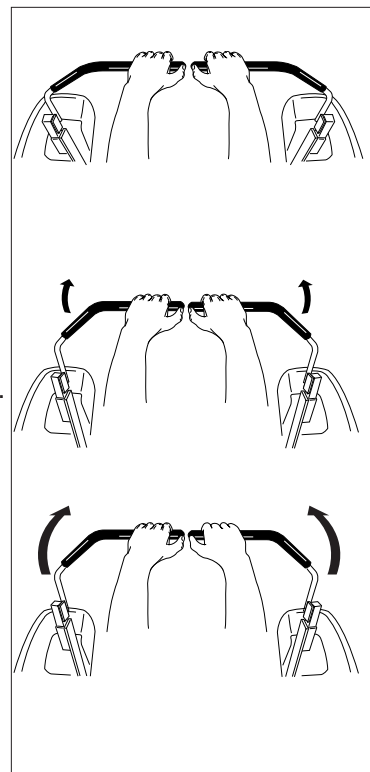

Figure 3. Move Control Levers Gradually

BASIC DRIVING

Forward Travel Practice

Gradually move both ground speed control levers — evenly FORWARD from neutral. Slow down and repeat.

NOTE: Straight forward travel takes practice. If necessary, top speed can be balance-adjusted — see the Speed Balancing Adjustment in the Adjustments section near the back of this manual.

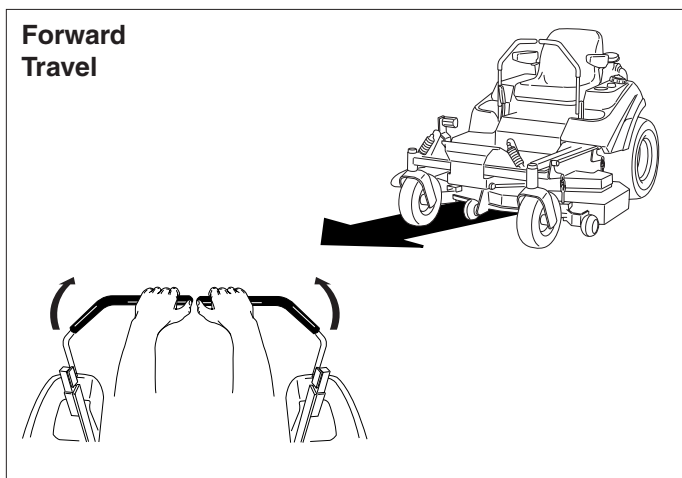

Figure 4. Forward Travel

Reverse Travel Practice

LOOK DOWN & BEHIND, then gradually move both ground speed control levers evenly BACK from neutral. Slow down and repeat.

NOTE: Practice backing up for several minutes before attempting to do so near objects. The rider turns sharply in reverse as well as forward, and backing up straight takes practice.

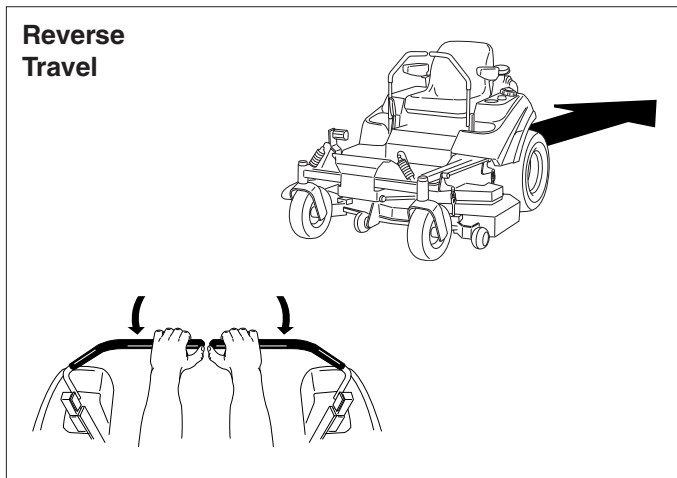

Figure 5. Reverse Travel

Practice Turning Around a Corner

While traveling forward bring one handle gradually back toward neutral. Repeat several times.

NOTE: To prevent pivoting directly on the tire tread, it is best to keep both wheels going at least slightly forward.

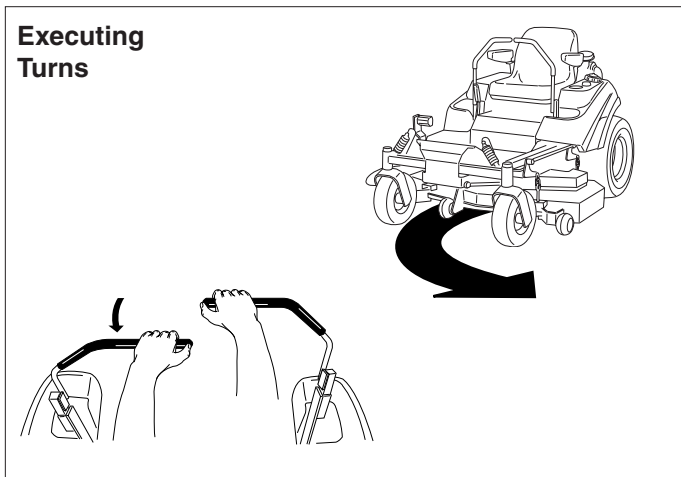

Figure 6. Turning Around a Corner

Practice Turning In Place

To turn in place, “Zero Turn,” gradually move one ground speed control lever forward from neutral and one lever back from neutral simultaneously. Repeat several times.

NOTE: Changing the amount each lever is pulled—forward or back, changes the “pivot point” you turn on.

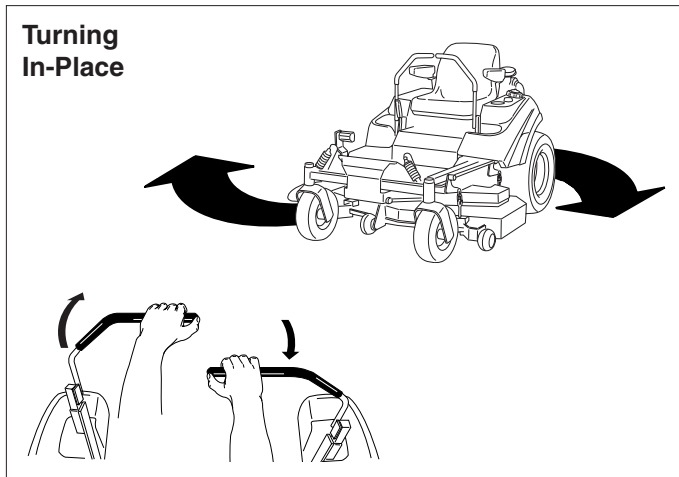

Figure 7. Turning in Place

ADVANCED DRIVING

Executing an End-Of-Row Zero Turn

Your Zero Turn Rider’s unique ability to turn in place allows you to turn around at the end of a cutting row rather than having to stop and Y-turn before starting a new row.

For example, to execute a left end-of row zero turn:

1. Slow down at the end of the row.
2. Move the RIGHT ground speed control lever forward slightly while moving the LEFT ground speed control lever back to center and then slightly back from center.
3. Begin mowing forward again.

This technique turns the rider LEFT and slightly overlaps the row just cut—eliminating the need to back up and re-cut missed grass.

As you become more familiar and experienced with operating the Zero Turn rider, you will learn more maneuvers that will make your mowing time easier and more enjoyable.

Remember, the more you practice, the better your control of the Zero Turn will be!

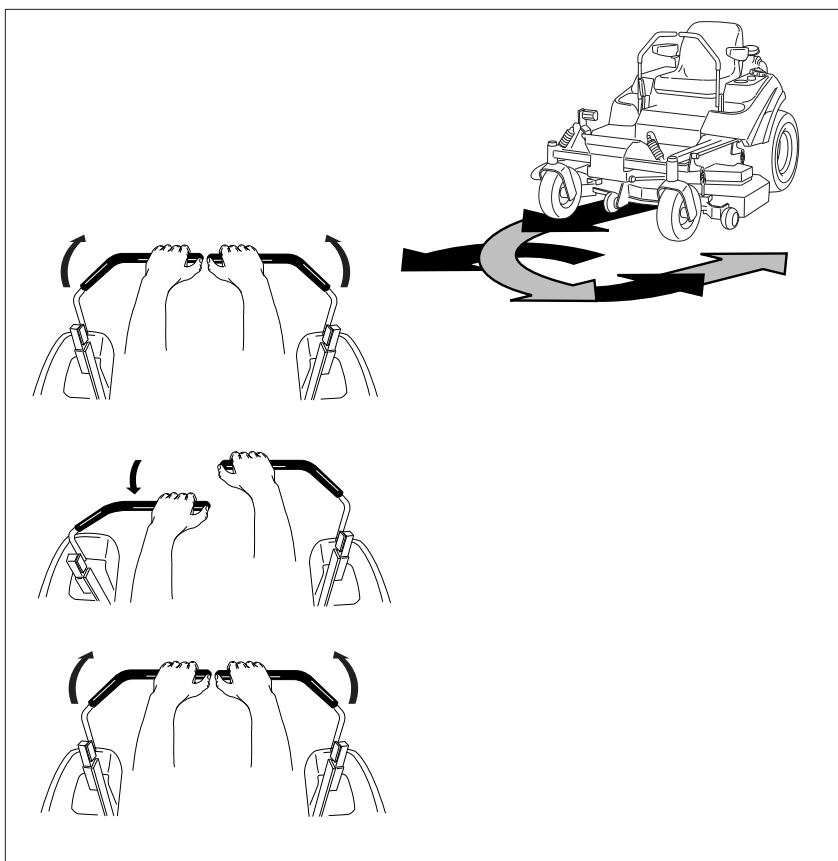

Figure 8. Executing an End-Of-Row Turn

RAISE & LOWER THE ROLL BAR

To lower the roll bar:

1. Pull the hair pin clips (A, Figure 9) out of the retainer pins (B).
2. Push or pull the top of the roll bar (C) forward against the rubber stops (D) and remove the retainer pins (B).
3. Lower the roll bar and reinstall the retainer pins and hair pin clips to secure the roll bar in the down position (see insert, Figure 10).

To raise the roll bar:

1. Pull the hair pin clips (A) out of the retainer pins (B) and remove the retainer pins.
2. Raise the roll bar (C) until the rubber stops (D) contact the upright tubes.
3. Push or pull the top of the roll bar forward against the rubber stops and reinstall the retainer pins and hair pin clips to secure the roll bar in the raised position.

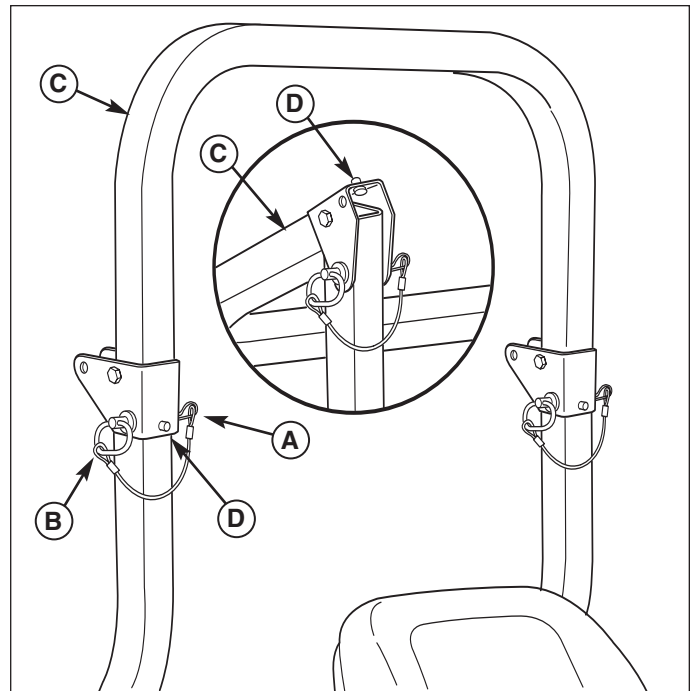

Figure 9. Raise & Lower the Roll Bar

- A. Hair Pin Clip
- B. Retainer Pin
- C. Roll Bar
- D. Rubber Stop

! WARNING

AVOID SERIOUS INJURY OR DEATH FROM ROLL OVER:

Keep roll bar in the raised position and use seat belt.

THERE IS NO ROLL OVER PROTECTION WHEN THE ROLL BAR IS DOWN

Lower the roll bar only when necessary and **NEVER** remove it.

Do NOT use seat belt when the roll bar is down.

Raise the roll bar as soon as clearance permits.

Do NOT jump off if mower tips.

Check for overhead clearances before driving under any objects. Do not allow roll bar to contact low overhanging obstacles such as tree branches and guide wires.

ATTACHING A TRAILER

The maximum weight of a towed trailer should be less than 200 lbs (91kg). Secure the trailer with a appropriately sized clevis pin (A, Figure 10) and clip (B).

Excessive towed loads can cause loss of traction and loss of control on slopes. Reduce towed weight when operating on slopes. The surface being driven on greatly impacts traction and stability. Wet or slippery surfaces can greatly reduce traction and the ability to stop or turn. Carefully evaluate the surface conditions before operating the unit and trailer, and never operate on slopes greater than 10°. See SLOPE OPERATION and TOWED EQUIPMENT in the safety section of this manual for additional safety information.

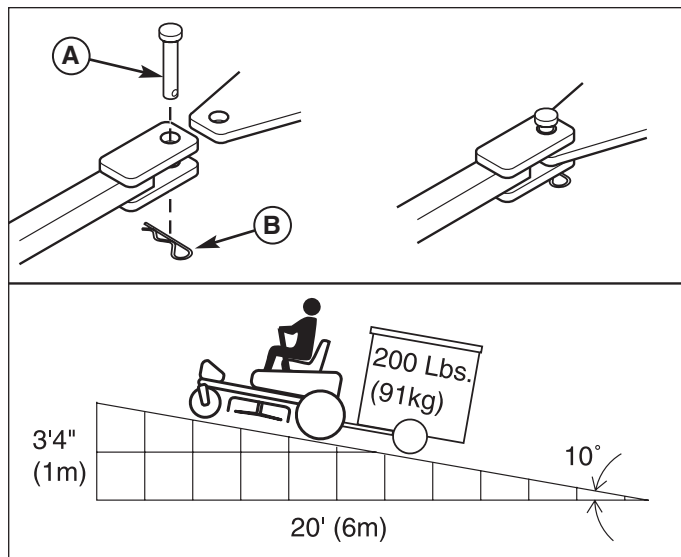

Figure 10. Trailer Weight Recommendations

A. Clevis Pin

B. Clip

STORAGE

⚠ WARNING

Never store the unit (with fuel) in an enclosed, poorly ventilated structure. Fuel vapors can travel to an ignition source (such as a furnace, water heater, etc.) and cause an explosion.

Fuel vapor is also toxic to humans and animals.

Before toy store your unit for the off-season, read the Maintenance and Storage instructions in the Safety Rules section, then perform the following steps:

- Disengage the PTO, set the parking brake, & remove the key.

- Perform engine maintenance and storage measures listed in the engine owner's manual. This includes draining the fuel system, or adding stabilizer to the fuel (do not store a fueled unit in an enclosed structure - see warning).
- Battery life will be increased if it is removed, put in a cool, dry place and fully charged about once a month. If the battery is left in the unit, disconnect the negative cable.

Before starting the unit after is has been stored:

- Check all fluid levels. Check all maintenance items.
- Perform all recommended checks and procedures found in the engine owner's manual.
- Allow the engine to warm up for several minutes before use.

Regular Maintenance



MAINTENANCE SCHEDULE

The following schedule should be followed for normal care of your rider and mower. You will need to keep a record of your operating time. Determining operating time is easily accomplished by observing the elapsed time recorded by the hour meter.

SAFETY ITEMS	Before Each Use	Every 5 Hours	Every 25 Hours	Every 100 Hours	Every 250 Hours	Spring & Fall
Check Safety Interlock System	•					•
Check Rider Brakes	•					•
Check Mower Blade Stopping Time				•		•
RIDER MAINTENANCE	Before Each Use	Every 5 Hours	Every 25 Hours	Every 100 Hours	Every 250 Hours	Spring & Fall
Check Rider / Mower for loose hardware	•	•				
Clean Deck & Check / Replace Mower Blades**			•			
Check / Adjust PTO Clutch				•		
Lubricate Rider & Mower **			•			
Clean Battery & Cables				•		
Check Tire Pressure			•			
Check Hydraulic Oil	•				•	
Change Hydraulic Oil Filter **					•	
ENGINE MAINTENANCE	Before Each Use	Every 5 Hours	Every 25 Hours	Every 100 Hours	Every 250 Hours	Spring & Fall
Check Engine Oil Level	•					
Check / Clean Cooling Fins & Intake **			•			
Service Air Filter *						
Change Oil & Filter *						
Check / Replace Spark Plugs *						
Check / Replace Fuel Filter *						

* Refer to engine owner's manual. Change original engine oil after initial break-in period.

** More often in hot (over 85° F: 30° C) weather or dusty operating conditions.

CHECK TIRE PRESSURES

Tire pressure should be checked periodically, and maintained at the levels shown in the chart. Note that these pressures may differ slightly from the “Max Inflation” stamped on the side-wall of the tires. The pressures shown provide proper traction, improve cut quality, and extend tire life.

Tire	Pressure
Front	25 psi (1,72 bar)
Rear	15 psi (1,03 bar)

CHECKING / ADDING FUEL

To add fuel:

1. Remove the fuel cap (see Figure 1).
2. Fill the tank to the bottom of the filler neck. This will allow for fuel expansion.

NOTE: Do not overfill. Refer to your engine manual for specific fuel recommendations.

3. Install and hand tighten the fuel cap.

FUEL FILTER

The fuel filter is located in the fuel line between fuel tank and carburetor, near the fuel pump. If filter is dirty or clogged, replace as follows:

1. Disconnect the negative battery cable.
2. Place a container below the filter to catch spilled fuel.
3. Using a pliers, open and slide hose clamps from fuel filter.
4. Remove hoses from filter.
5. Install new filter in proper flow direction in fuel line.
6. Secure with hose clamps.
7. Reconnect the negative battery cable when finished.

CHANGE OIL & FILTER

1. Warm engine by running for a few minutes. (Refer to the engine operator’s manual for oil & filter replacement instructions.)
2. Remove the oil drain hose (A, Figure 12) from the cable clamp (C) on the right-hand side of the frame and route the hose towards the rear of the machine as shown in Figure 12.
3. Place a small pan under the oil drain hose to catch the oil. Using the appropriate tools, remove the cap (B, Figure 12) from the oil drain hose (A) and drain the engine oil.
4. After draining, replace the cap and wipe up any spilled oil. Reinstall the oil drain hose into the cable clamp to retain the hose during normal operation.
5. Place an absorbent shop cloth under the engine oil filter. Remove the engine oil filter and replace with a new one.
6. Remove the shop cloth and wipe up any spilled oil.

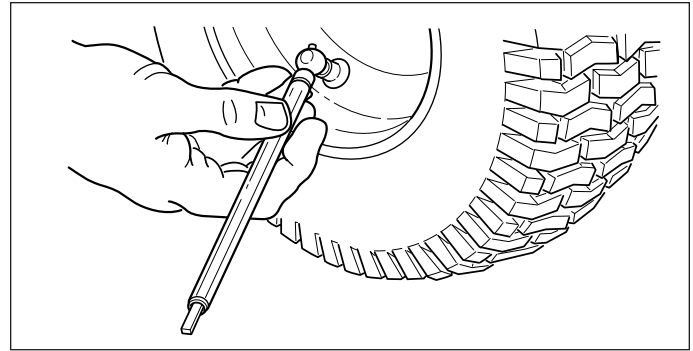

Figure 11. Checking Tire Pressure

⚠ WARNING

Gasoline is highly flammable and must be handled with care. Never fill the tank when the engine is still hot from recent operation. Do not allow open flame, smoking or matches in the area. Avoid over-filling and wipe up any spills.

Do not remove fuel filter when engine is hot, as spilled gasoline may ignite. DO NOT spread hose clamps further than necessary. Ensure clamps grip hoses firmly over filter after installation.



Do not use gasoline containing METHANOL, gasohol containing more than 10% ethanol, gasoline additives, premium gasoline, or white gas because engine/fuel system damage could result.

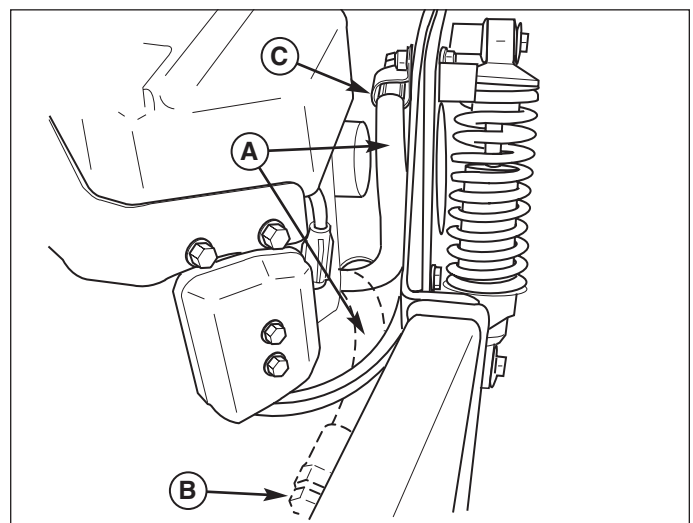

Figure 12. Engine Oil Drain

- A. Oil Drain Hose
- B. Cap
- C. Cable Clamp

ENGINE MAINTENANCE

Refer to engine owner’s manual for all engine maintenance procedures and recommendations.

Regular Maintenance

LUBRICATION

Lubricate the unit at the locations shown in Figures 13 through 16 as well as the following lubrication points.

Grease:



- front caster wheel axles & yokes
- deck lift pivot blocks
- mower deck spindles
- mower deck idler arm

Use grease fittings when present. Disassemble parts to apply grease to moving parts when grease fittings are not installed.

Not all greases are compatible. Red Grease (p/n 5022285) is recommended, automotive-type high-temperature, lithium grease may be used when this is not available.

Oil:



- control handle pivots
- seat plate pivots
- deck lift pivots
- discharge chute hinge

Generally, all moving metal parts should be oiled where contact is made with other parts. Keep oil and grease off belts and pulleys. Remember to wipe fittings and surfaces clean both before and after lubrication.

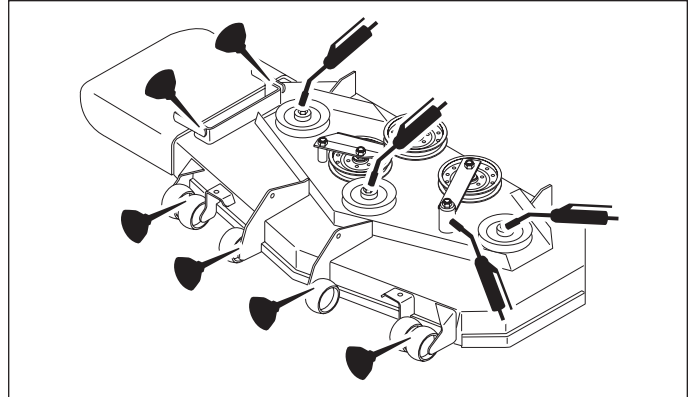

Figure 13. Deck Lubrication

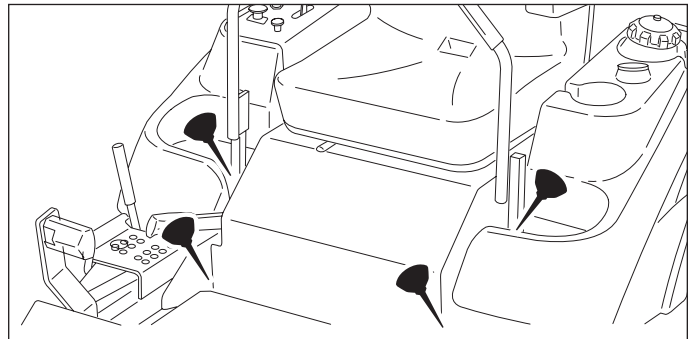

Figure 14. Control Handle Pivots & Seat Plate Pivots

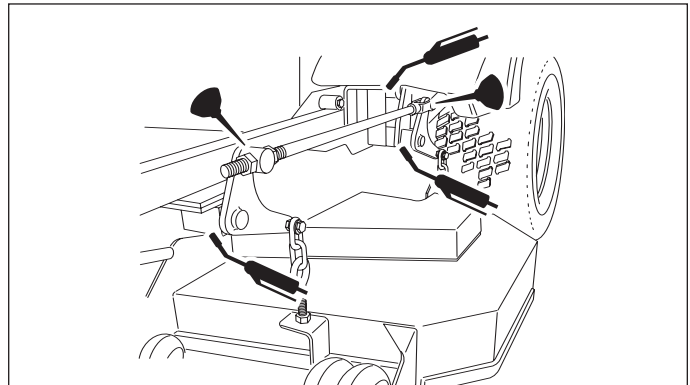

Figure 15. Deck Lift Linkage Pivots

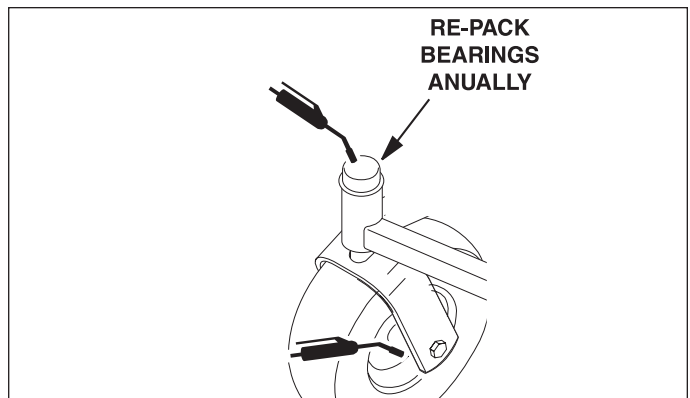

Figure 16. Front Caster & Wheel

CHECK HYDRAULIC OIL LEVEL

1. Before removing the reservoir cap, make sure the area around the reservoir cap and fill neck of the reservoir is free of dust, dirt, or other debris.
2. Unscrew the reservoir cap (B, Figure 17).
3. Look down the filler neck of the hydraulic oil reservoir (A, Figure 17) and observe the oil level. When cold, the oil level should be approximately 4" (10 cm) below top of the filler neck.
4. If necessary, add either Mobil 1™, 15W-50 synthetic oil or Castrol Syntec™ 5W-50 oil. **DO NOT** use conventional oils.
5. Reinstall the reservoir cap.

CHANGE HYDRAULIC OIL FILTER

Change Interval: Every 250 Hours

Filter Part Number: 1719168

NOTE: Removing the oil filter from the filter base will drain the oil reservoir. Have a suitable container ready to catch any spilled oil. It is recommended that this be a dealer-only service item.

1. Locate the transmission oil filter (E, Figure 18) at the rear of the battery compartment under the seat.
2. Lubricate the new filter base with a few drops of transmission oil. Fill the filter half full of oil.
3. Clean the area around the filter base and remove the filter. Do NOT drain the hydraulic system oil.
4. Thread the new filter onto the filter base until the gasket makes contact, then tighten 3/4 of a turn more.
5. Run the unit for several minutes and check the transmission oil level.

IMPORTANT NOTE: Use caution after changing the filter; air in the hydraulic system may affect the responsiveness of the control levers. Repeat step 5 until the air is out of the system.

BATTERY MAINTENANCE

NOTE: This unit is equipped with a maintenance-free BCIU1 battery.

Cleaning the Battery and Cables

1. Remove the hydraulic oil reservoir mounting hardware (C, Figure 18) and move the reservoir (D) forward to expose the battery.
2. Disconnect the cables from the battery, negative (black) cable first (B).
3. Clean the battery terminals and cable ends with a wire brush until shiny.
4. Reinstall the battery and reattach the battery cables, positive (red) cable first (A).
5. Coat the cable ends and battery terminals with petroleum jelly or non-conducting grease.
6. Reposition the oil reservoir and secure in place with the hardware previously removed.

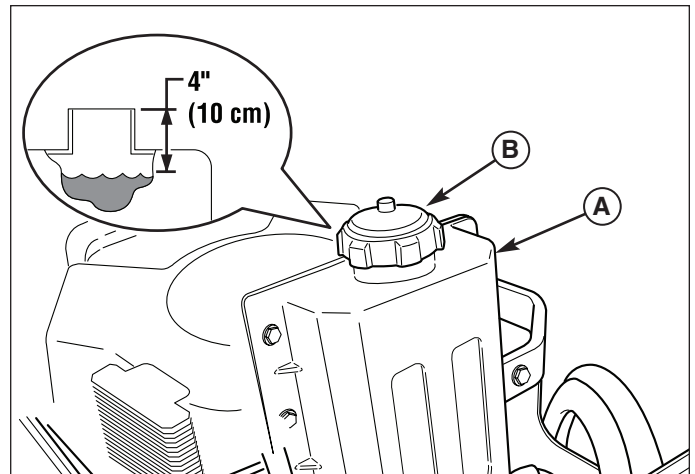

Figure 17. Checking Hydraulic Oil Level

A. Hydraulic Oil Reservoir

B. Reservoir Cap

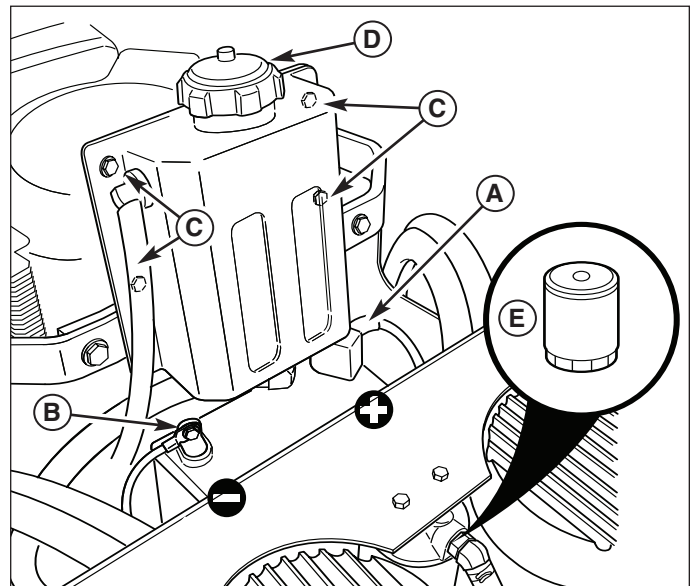

Figure 18. Battery Compartment

A. Positive (+) Cable & Terminal

B. Negative (-) Cable & Terminal

C. Reservoir Mounting Hardware

D. Hydraulic Oil Reservoir

E. Hydraulic Oil Filter

⚠ WARNING

Be careful when handling the battery. Avoid spilling electrolyte. Keep flames and sparks away from the battery.

When removing or installing battery cables, disconnect the negative cable FIRST and reconnect it LAST. If not done in this order, the positive terminal can be shorted to the frame by a tool.

Regular Maintenance

SERVICING THE MOWER BLADES

1. Blades should be sharp and free of nicks and dents. If not, sharpen blades as described in the following steps.
2. To remove blade for sharpening, use a 1" wrench on the flats of the spindle shaft while removing the blade mounting bolt with a 15/16" wrench (Figure 19).
3. Use a file to sharpen blade to fine edge. Remove all nicks and dents in blade edge. If blade is severely damaged, it should be replaced.
4. Balance the blade as shown in Figure 20. Center the blade's hole on a nail lubricated with a drop of oil. A balanced blade will remain level.
5. Reinstall each blade with the tabs pointing up toward deck as shown in Figure 21. Secure with a bolt and flat washer and torque bolts to 70 ft.lbs. (94 Nm).

! WARNING

Mower blades are sharp. For your personal safety, do not handle mower blades with bare hands. Careless or improper handling of blades may result in serious injury. For your personal safety, blade mounting bolts must each be installed with a flat washer then securely tightened. Torque blade mounting bolts to 70 ft.lbs. (94 Nm)

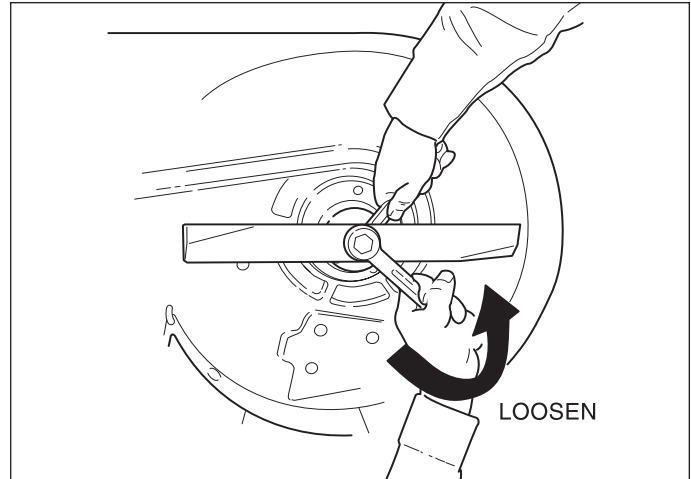

Figure 19. Removing the Blade

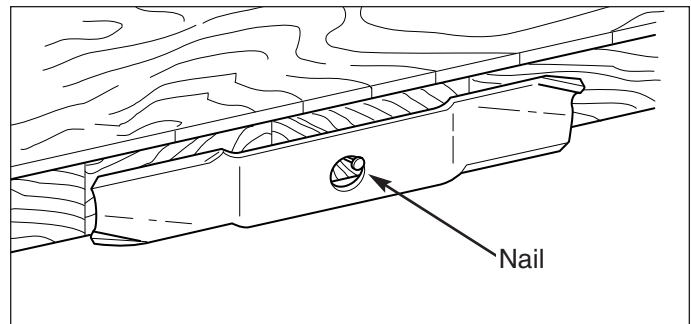

Figure 20. Balancing The Blade

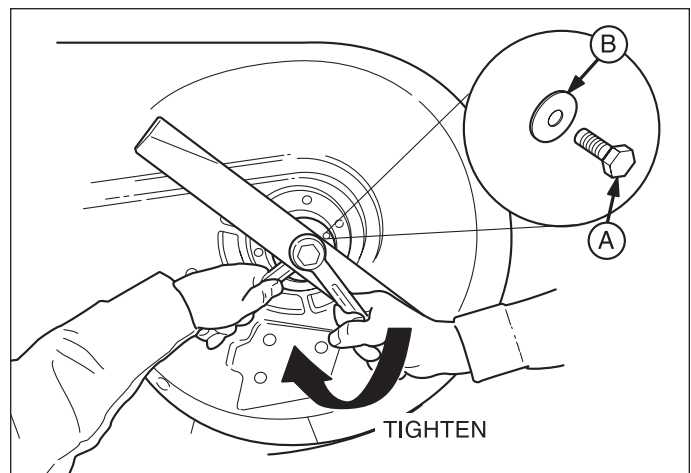

Figure 21. Installing The Blade

- A. Blade Bolt
- B. Flat Washer



Troubleshooting Adjustments & Service

TROUBLESHOOTING

While normal care and regular maintenance will extend the life of your equipment, prolonged or constant use may eventually require that service be performed to allow it to continue operating properly.

The troubleshooting guide below lists the most common problems, their causes and remedies.

See the information on the following pages for instructions on how to perform most of these minor adjustments and service repairs yourself. If you prefer, all of these procedures can be performed for you by your local authorized dealer.

⚠ WARNING

To avoid serious injury, perform maintenance on the tractor or mower only when the engine is stopped and the parking brake engaged.

Always remove the ignition key, disconnect the spark plug wire and fasten it away from the plug before beginning the maintenance, to prevent accidental starting of the engine.

TROUBLESHOOTING THE RIDER

PROBLEM	CAUSE	REMEDY
Engine will not turnover or start.	<ol style="list-style-type: none"> 1. Parking brake not engaged. 2. PTO (electric clutch) switch in ON position. 3. Out of fuel. 4. Engine flooded. 5. Fuse blown. 6. Battery terminals require cleaning. 7. Battery discharged or dead. 8. Wiring loose or broken. 9. Solenoid or starter motor faulty. 10. Safety interlock switch faulty. 11. Spark plug(s) faulty, fouled or incorrectly gapped. 12. Water in fuel. 13. Gas is old or stale. 	<ol style="list-style-type: none"> 1. Engage parking brake. 2. Place in OFF position. 3. If engine is hot, allow it to cool, then refill the fuel tank. 4. Move choke control to closed position. 5. Replace fuse. 6. Clean the battery terminals 7. Recharge or replace. 8. Visually check wiring & replace broken or frayed wires. Tighten loose connections. 9. Repair or replace. See authorized dealer 10. Replace as needed. See authorized service dealer. 11. Clean and gap or replace. See engine manual. 12. Drain fuel & replace with fresh fuel. 13. Drain fuel & replace with fresh fuel.
Engine starts hard or runs poorly.	<ol style="list-style-type: none"> 1. Fuel mixture too rich. 2. Spark plug faulty, fouled, or incorrectly gapped. 	<ol style="list-style-type: none"> 1. Clean air filter. Check choke adjustment. 2. Clean and gap or replace. (See engine manual.)
Engine knocks.	<ol style="list-style-type: none"> 1. Low oil level. 2. Using wrong grade oil. 	<ol style="list-style-type: none"> 1. Check/add oil as required. 2. See engine manual.
Excessive oil consumption.	<ol style="list-style-type: none"> 1. Engine running too hot. 2. Using wrong weight oil. 3. Too much oil in crankcase. 	<ol style="list-style-type: none"> 1. Clean engine fins, blower screen and air cleaner. 2. See engine manual. 3. Drain excess oil.
Engine exhaust is black.	<ol style="list-style-type: none"> 1. Dirty air filter. 2. Engine choke control is in closed position. 	<ol style="list-style-type: none"> 1. Replace air filter. See engine manual. 2. Open choke control.

Troubleshooting, Adjustment & Service

Rider Troubleshooting Continued.

PROBLEM	CAUSE	REMEDY
Engine runs, but rider will not drive.	<ol style="list-style-type: none"> 1. Hydraulic release valve(s) in "open" position. 2. Belt is broken. 3. Drive belt slips. 4. Brake is not fully released. 	<ol style="list-style-type: none"> 1. Turn valve(s) clockwise to close. 2. See Drive Belt Replacement. 3. See problem and cause below. 4. See authorized service dealer
Rider drive belt slips.	<ol style="list-style-type: none"> 1. Pulleys or belt greasy or oily. 2. Tension too loose. 3. Belt stretched or worn. 	<ol style="list-style-type: none"> 1. Clean as required. 2. Adjust spring tension. See Drive Belt Replacement 3. Replace belt.
Brake will not hold.	<ol style="list-style-type: none"> 1. Brake is incorrectly adjusted. 2. Brake pads worn. 	<ol style="list-style-type: none"> 1. See Brake Adjustment. 2. Replace with new brake pads.
Rider steers or handles poorly.	<ol style="list-style-type: none"> 1. Steering linkage is loose. 2. Improper tire inflation. 	<ol style="list-style-type: none"> 1. Check and tighten any loose connections. 2. See Regular Maintenance Section.

TROUBLESHOOTING THE MOWER

PROBLEM	CAUSE	REMEDY
Mower will not raise.	<ol style="list-style-type: none"> 1. Lift linkage not properly attached or damaged. 	<ol style="list-style-type: none"> 1. See authorized service dealer for repair.
Mower cut is uneven.	<ol style="list-style-type: none"> 1. Mower not leveled properly. 2. Rider tires not inflated equally or properly. 	<ol style="list-style-type: none"> 1. See Mower Adjustment. 2. See Regular Maintenance Section.
Mower cut is rough looking.	<ol style="list-style-type: none"> 1. Engine speed too slow. 2. Ground speed too fast. 3. Blades are dull. 4. Mower drive belt slipping because it is oily or worn. 5. Blades not properly fastened to arbors. 	<ol style="list-style-type: none"> 1. Set throttle to full. 2. Decrease Ground Speed. 3. Sharpen or replace blades. See Mower Blade Service. 4. Clean or replace belt as necessary. 5. See Servicing the Mower Blades.
Engine stalls easily with mower engaged.	<ol style="list-style-type: none"> 1. Engine speed too slow. 2. Ground speed too fast. 3. Cutting height set too low. 4. Discharge chute jamming with cut grass. 	<ol style="list-style-type: none"> 1. Set to full throttle. 2. Decrease Ground Speed. 3. Cut tall grass at maximum cutting height during first pass. 4. Cut grass with discharge pointing toward previously cut area.
Excessive mower vibration.	<ol style="list-style-type: none"> 1. Blade mounting bolts are loose. 2. Mower blades, arbors, or pulleys are bent. 3. Mower blades are out of balance. 4. Belt installed incorrectly. 	<ol style="list-style-type: none"> 1. Tighten to 70 ft.lbs. (94 Nm). 2. Check and replace as necessary. 3. Remove, sharpen, and balance blades. See Maintenance Section. 4. Reinstall Correctly.
Excessive belt wear or breakage.	<ol style="list-style-type: none"> 1. Bent or rough pulleys. 2. Using incorrect belt. 	<ol style="list-style-type: none"> 1. Repair or replace. 2. Replace with correct belt.
Mower drive belt slips or fails to drive.	<ol style="list-style-type: none"> 1. Idler pulley spring broken or not properly attached. 2. Mower drive belt broken. 	<ol style="list-style-type: none"> 1. Repair or replace as needed. 2. Replace drive belt.
Mower does not engage.	<ol style="list-style-type: none"> 1. Electrical wiring damage. 2. PTO clutch not adjusted 3. Battery voltage too low. 	<ol style="list-style-type: none"> 1. Locate & repair damaged wire. 2. See PTO Clutch Adjustment section 3. Recharge battery and check alternator. See Battery Maintenance section.

SEAT ADJUSTMENT

See Figure 22. The seat can be adjusted forward and back. Move the lever towards the left, position the seat as desired, and release the lever to lock the seat into position.

GROUND SPEED CONTROL LEVER ADJUSTMENT

The control levers can be adjusted in three ways. The alignment of the control levers, the placement of the levers (how close the ends are to one another) and the height of the levers can be adjusted.

To Adjust the Lever Alignment

Loosen the mount bolts (A, Figure 23) and pivot the lever(s) (C) to align with each other.

To Adjust the Lever Placement

Loosen the jam nuts and adjust the placement bolt (B, Figure 23) in or out to properly adjust the lever end spacing.

To Adjust the Lever Height

Remove the mounting hardware and reposition the handle either up or down from its original position. You will need to readjust the handle alignment as described above.

SPEED BALANCING ADJUSTMENT

If the rider veers to the right or left when the ground speed control levers are in the maximum forward position, the top speed of each of these levers can be balanced by turning the adjustment bolt(s) (A, Figure 24). Only adjust the speed of the wheel that is traveling faster.

To Reduce the Speed of the Faster Wheel

1. Loosen the securing nut.
2. Turn the top speed adjustment bolt COUNTER-CLOCKWISE to reduce the speed.
3. Retighten the securing nut when adjustment is complete.

WARNING

DO NOT adjust the rider for a faster overall speed forward or reverse than it was designed for.

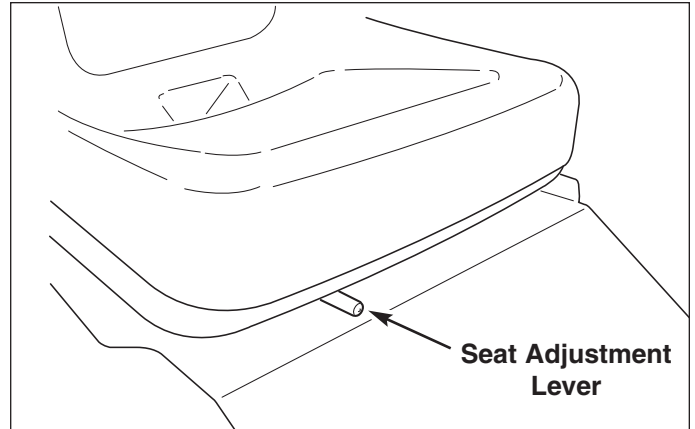

Figure 22. Seat Adjustment

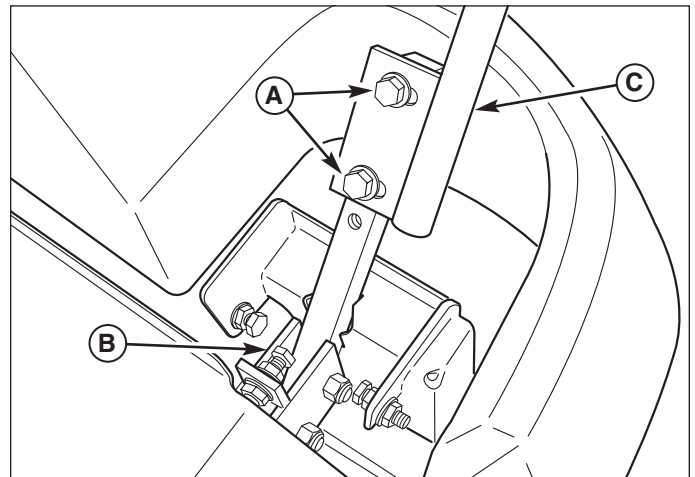

Figure 23. Control Lever Adjustment

- A. Alignment Hardware
- B. Placement Hardware
- C. Ground Speed Control Lever

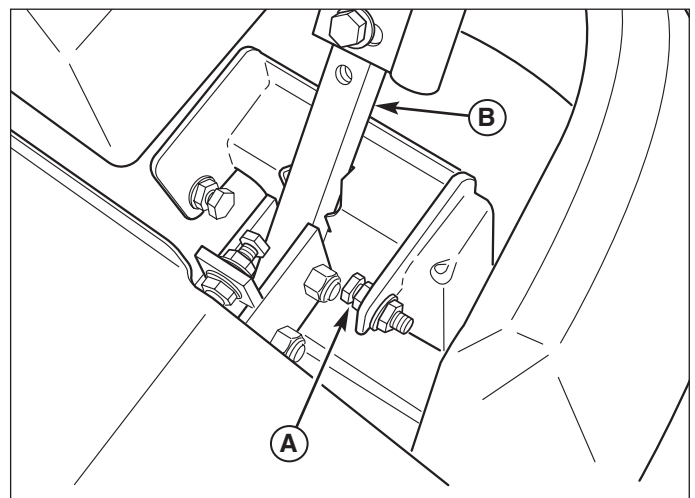

Figure 24. Top Speed Adjustment

- A. Top Speed Adjustment Bolt
- B. Control Lever Base

Troubleshooting, Adjustment & Service

PARKING BRAKE ADJUSTMENT

1. Disengage the PTO, engage the parking brake, stop the engine and remove the ignition key.
2. Raise the seat plate.
3. Locate the brake spring (A, Figure 25).
4. With the parking brake engaged, measure the compressed spring length. The spring should be 1-15/16" - 2" (4,9 - 5,1 cm) when compressed.
5. If the spring is not within this range, release the parking brake and turn the adjustment nut (B) to compress or release the spring.
6. Engage the parking brake and remeasure the spring.

! CAUTION

Do not adjust the spring to be shorter than 1-15/16" (4,9 cm) when compressed. This may damage the brake mechanism.

If this does not correct the braking problem, see your dealer.

BATTERY CHARGING

A dead battery or one too weak to start the engine may be the result of a defect in the charging system or other electrical component. If there is any doubt about the cause of the problem, see your dealer. If you need to replace the battery, follow the steps under Cleaning the Battery & Cables in the Regular Maintenance Section.

To charge the battery, follow the instructions provided by the battery charger manufacturer as well as all warnings included in the safety rules sections of this book. Charge the battery until fully charged. Do not charge at a rate higher than 10 amps.

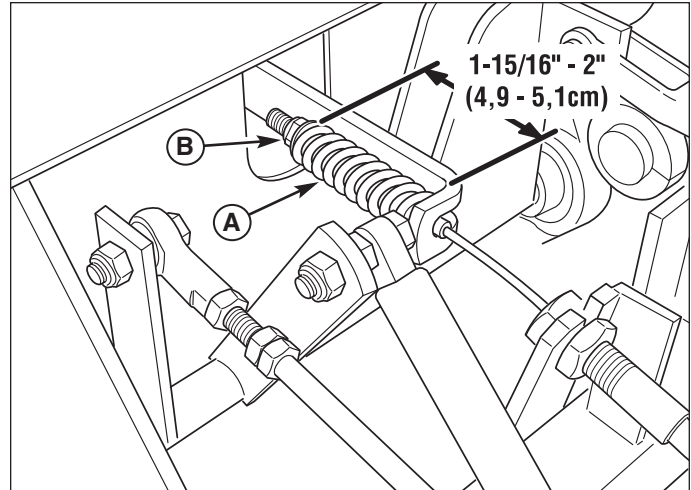

Figure 25. Parking Brake Adjustment
A. Brake Spring
B. Adjustment Nut

! WARNING

Keep open flames and sparks away from the battery; the gasses coming from it are highly explosive. Ventilate the battery well during charging.

REAR SUSPENSION ADJUSTMENT

The shock assembly can be adjusted in two ways to allow the operator to customize the ride according to operator's weight and/or operating conditions. You have the option of adjusting the spring pre-load and/or the upper mounting position.

Items to consider before adjusting the suspension.

- Less spring pre-load should be used with light weight operators, which will provide a softer, more cushioned ride.
- More spring pre-load or upper mounting position #2 should be used with heavy weight operators, or when a rear-mount grass bagger system is installed, which will provide a stiffer, more rigid ride.

To adjust the spring pre-load:

1. Park machine on a flat, level surface. Disengage the PTO, stop the engine and engage the parking brake.
2. Raise the rear of the machine and secure with jackstands. Chock the front wheels to prevent the machine from rolling.
3. Remove the rear drive tires.
4. See Figure 26. Using the supplied spanner wrench (p/n 5022853), insert the tip of the wrench into the notch in the pre-load adjuster. While holding the wrench in place with one hand, turn COUNTER-CLOCKWISE to increase the pre-load, turn CLOCKWISE to decrease the pre-load. Make sure both shocks are set to the same amount of pre-load.
5. Reinstall the rear drive tires. Torque the lug bolts to 85-95 ft/lbs. (115-129 Nm). Remove the jackstands from under the machine.

NOTE: Spanner wrench is located under the seat on the right-hand side of the machine.

To adjust the upper mounting position:

1. Park machine on a flat, level surface. Disengage the PTO, stop the engine and engage the parking brake.
2. Raise the rear of the machine and secure with jackstands. The jackstands must under the bumper. Chock the front wheels to prevent the machine from rolling.
3. Position the jack under the cross member that ties the suspension arms together and slowly raise the rear suspension to relieve the pressure on the upper shock mounting bolts.
4. Remove the upper shock mounting hardware and pivot the shock to the position #2 (see Figure 26). Adjust the jack to align the shock mounts to the shocks.
5. Reinstall the upper shock mounting hardware and tighten securely.
6. Remove the jack from under the suspension cross member.
7. Remove the jackstands from under the machine.

NOTE: This will require small adjustments to the jack's position. The shock should move freely on the mounting bolt when the pressure is relieved.

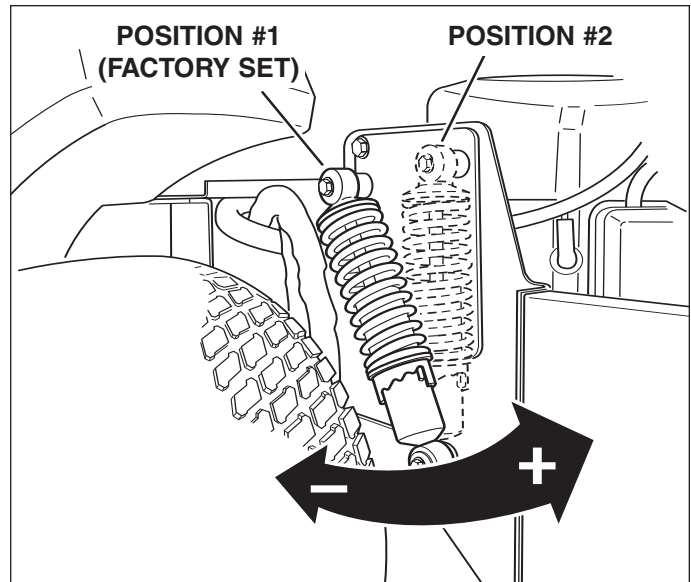

Figure 26. Rear Suspension Adjustments

! WARNING

Use two hands when adjusting the shock springs. This will prevent the wrench from slipping while pressure is being applied.

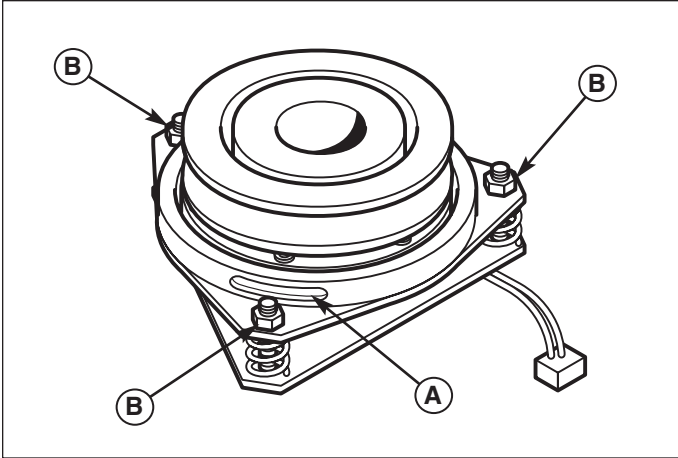

Figure 27. PTO Clutch Adjustment

- A. Adjustment Window (Qty. 3, one shown)
- B. Adjustment Nut

PTO CLUTCH ADJUSTMENT

Check the PTO clutch adjustment after every 100 hours of operation. Also perform the following procedure if the clutch is slipping or will not engage, or if a new clutch has been installed.

1. Remove key from ignition switch and disconnect spark plug wires to prevent the possibility of accidental starting while the PTO is being adjusted.
2. See Figure 27. Note the position of the 3 adjustment windows (A) in the side of the brake plate and the nylock adjustment nuts (B).
3. Insert a .016"-.018" (0,40-0,45mm) feeler gauge (C) through each window, positioning the gauge between the rotor face and the armature face as shown in Figure 28.
4. Alternately tighten the adjustment nuts (B, Figure 27) until the rotor face and armature face just contacts the gauge.
5. Check the windows for an equal amount of tension when the gauge is inserted and removed, and make any necessary adjustments by tightening or loosening the adjustment nuts.

NOTE: The actual air gap between the rotor and armature may vary even after performing the adjustment procedure. This is due to dimensional variations on component parts, and is an acceptable condition.

6. Check the mower blade stopping time. The mower blades and mower drive belt should come to a complete stop within seven (7) seconds after the electric PTO switch is turned off.

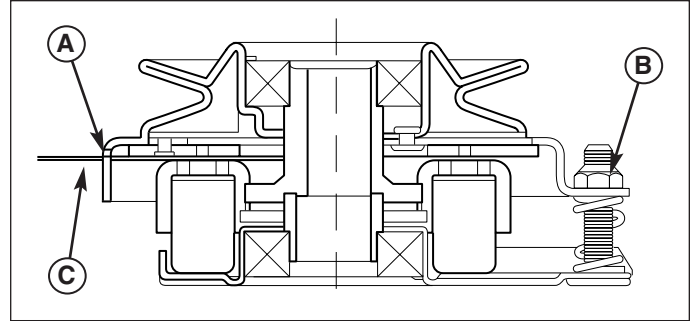

Figure 28. Adjust PTO Clutch

- A. Window
- B. Adjustment Nut
- C. .016"-.018" (0,40-0,45mm) Feeler Gauge

⚠ WARNING

To avoid serious injury, perform adjustments only with engine stopped, key removed and tractor on level ground.

Blade Brake Check

Mower blades and mower drive belt should come to a complete stop within seven (7) seconds after electric PTO switch is turned off.

1. With parking brake engaged, PTO disengaged and an operator in the seat, start the engine.
2. Have an assistant observe the mower drive belt through the open end of the left-hand arbor cover. Engage the PTO and wait several seconds. Disengage the PTO and check the amount of time it takes for the mower drive belt to stop.
3. If the mower drive belt does not stop within seven (7) seconds, perform the PTO Clutch Adjustment. If the belt still does not stop within seven (7) seconds, see your dealer.

RETURN-TO-NEUTRAL ADJUSTMENT

To determine if it is necessary to adjust the neutral return, perform the following steps.

1. Disengage the PTO, engage the parking brake and turn off the engine.
2. Move the ground speed control levers into the operating position, pull levers rearward and release.
3. Move the ground speed control levers out towards the neutral position. If the levers do not align with the notches in the neutral lock plate, it is necessary to adjust the neutral return rod (C, Figure 29).

Adjustment

1. Loosen the jam nut (B) locked against the clevis (A).
2. Turn the neutral return rod (C) to adjust handle position.
4. Pull lever rearward and release to check position again. Adjust as necessary to align levers with notches.

It is important to note that after every adjustment of the neutral return rod, the lever must be pulled rearward and released to properly check the neutral position.

5. Once the lever alignment has been adjusted, lock jam nut against the clevis.

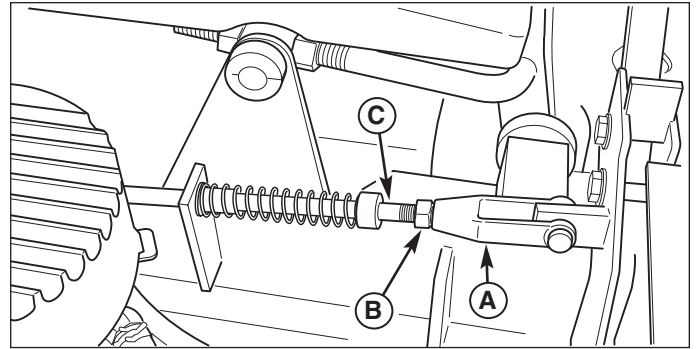

Figure 29. Neutral Spring Return Adjustment

- A. Clevis
- B. Jam Nut
- C. Neutral Return Rod

NEUTRAL ADJUSTMENT

If the tractor “creeps” while the ground speed control levers are locked in NEUTRAL, then it may be necessary to adjust the linkage rod.

NOTE: Perform this adjustment on a hard, level surface such as a concrete floor.

1. Disengage the PTO, engage the parking brake and turn off the engine.
2. There are three nuts (B, Figure 30) on the linkage rod. The first two are to be used together to turn the rod and the third (towards the front of the machine) is used to lock the rod in place. Loosen the jam nut that locks against the ball joint (B, Figure 30) and turn the linkage rod (A) to adjust. If the machine creeps forward, turn the rod CLOCKWISE (while standing at the rear of the machine, facing forward), if the machine creeps backward, turn the rod COUNTER-CLOCKWISE.
3. Lock the jam nut (B) against the ball joint when neutral is achieved.

NOTE: This adjustment should not be performed while the machine is running. It may take several attempts to achieved neutral, depending upon how much the machine creeps.

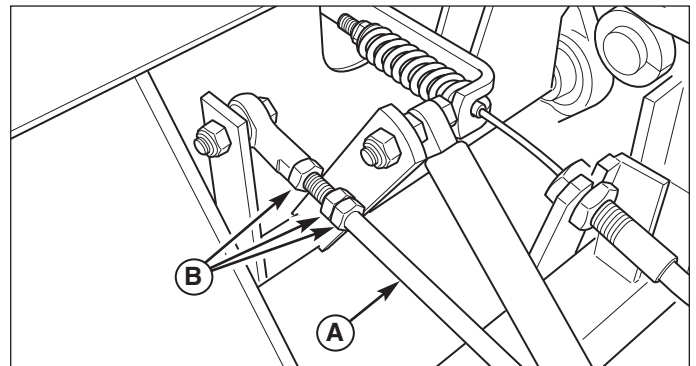

**Figure 30. Neutral Adjustment
(RH side shown)**

- A. Adjustment Linkage Rod
- B. Nuts

Troubleshooting, Adjustment & Service

MOWING HEIGHT ADJUSTMENT

The cutting height adjustment pin (A, Figure 31) controls the mower cutting height. The cutting height is adjustable between 1-3/4" (4,4 cm) and 5" (12,7 cm) in 1/4" (0,64 cm) increments.

1. Depress the deck lift foot pedal (B) until it locks into the 5" (12,7 cm) position.
2. Place the cutting height adjustment pin in the desired cutting height.
3. Depress the deck lift foot pedal then push the lock lever (C) towards the right to release the lock.
4. Release the deck lift foot pedal until it comes to rest against the cutting height adjustment pin.

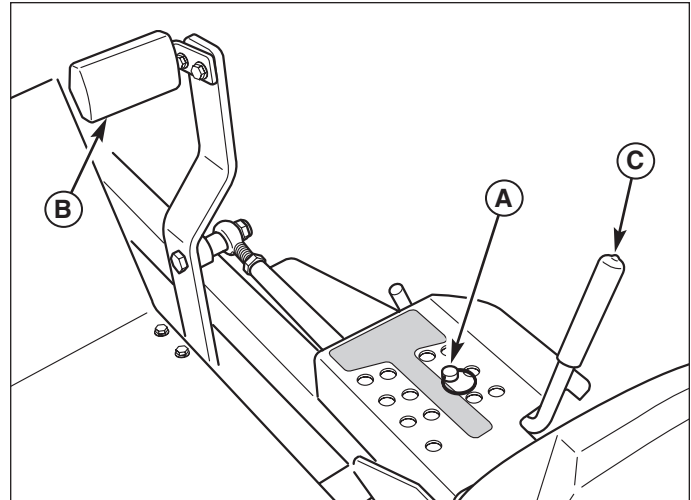

Figure 31. Mowing Height Adjustment
A. Cutting Height Adjustment Pin
B. Deck Lift Foot Pedal
C. Deck Lift Lock lever

FOOT PEDAL ADJUSTMENT

The deck lift foot pedal can be adjusted to accommodate the operator's height for optimal comfort.

To adjust pedal position:

1. Remove the foot pedal (A, Figure 32) from the pedal mount tab (B).
2. Remove the pedal mount hardware (C) and rotate the tab 180 degrees.
3. Reinstall the pedal mount hardware and tighten securely.
4. Reinstall the foot pedal on the pedal mount tab in the proper orientation as shown in Figure 32.

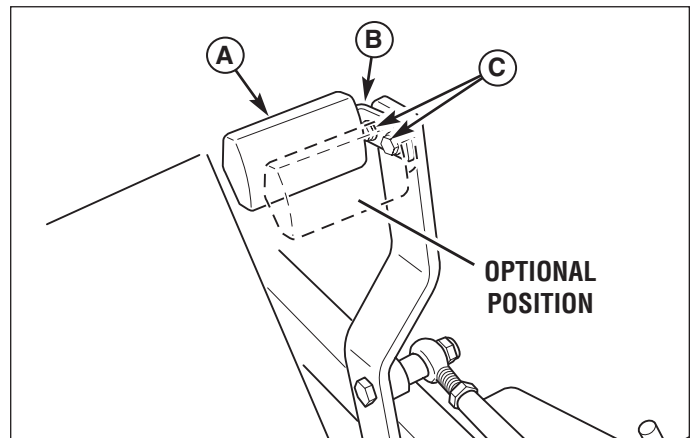

Figure 32. Foot Pedal Adjustment
A. Deck Lift Foot Pedal
B. Pedal Mount Tab
C. Pedal Mount Hardware

DECK LEVELING ADJUSTMENT

1. Park machine on a flat, level surface. Disengage the PTO, stop the engine and engage the parking brake. Rear tires must be inflated to 15 psi (1,03 bar); front tires to 25 psi (1,72 bar).
2. To check the lift rod timing, measure and record the distance between the lift pivots and the rod pivots. Repeat for other side of unit. See Figure 33.
3. If the measurements are equal, skip to Step 5. If the measurements are NOT equal (greater than 1/8" (3,17mm) difference), adjustment is required, continue with Step 4.
4. Refer to Figure 34. To adjust the lift rod timing, adjust the 5/8" hex nuts on either side of the front lift pivot until the measurements are equal. Repeat for other side.
5. Place the deck height adjustment pin in the 4" (10,2 cm) position.
6. Place 2 x 4 blocks under each corner of the mower deck with the 3-1/2" sides being vertical. Place a 1/4" (0,64 cm) thick spacer on top of the rear 2 x 4 blocks. See Figure 35.
7. Adjust the front eyebolts until the chains are tight and the deck is still resting on the 2 x 4's. Tighten jam nuts. See Figure 36.
8. Loosen the nuts and allow the rear of the deck to rest on the 2 x 4's and 1/4" spacers. Slide the chains in the slots until the chains are tight and tighten the nuts. See Figure 36.
9. Remove all 2 x 4 blocks and spacers from under the mower deck.

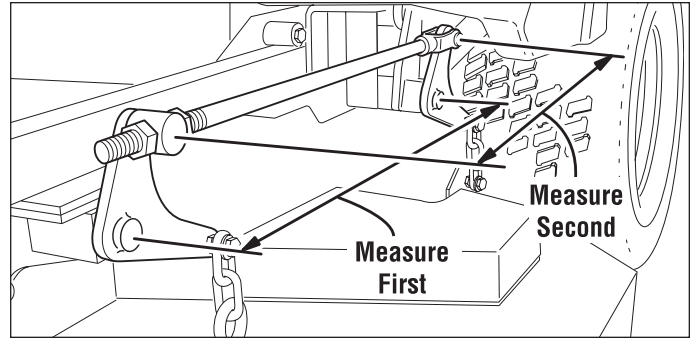

Figure 33. Check Lift Rod Timing

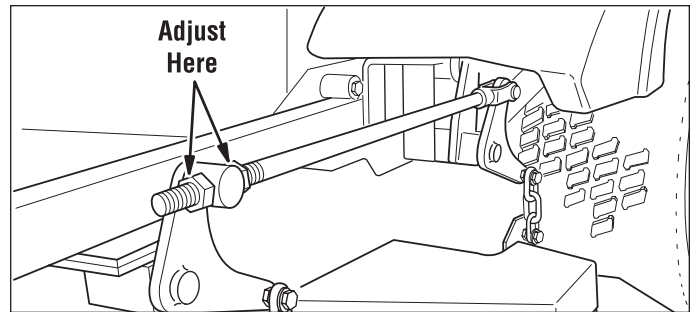

Figure 34. Adjust Lift Rod Timing

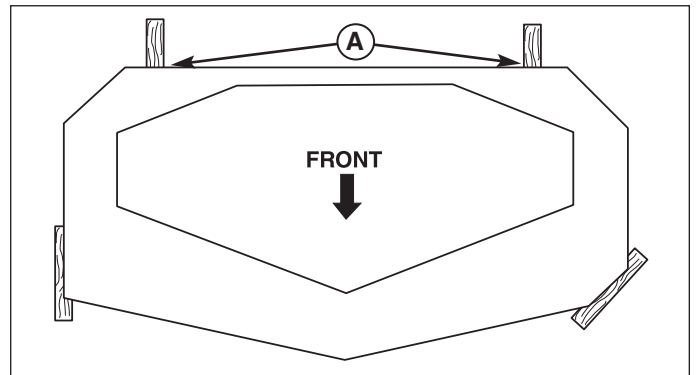

Figure 35. 2 x 4 Locations
A. 1/4" Spacers

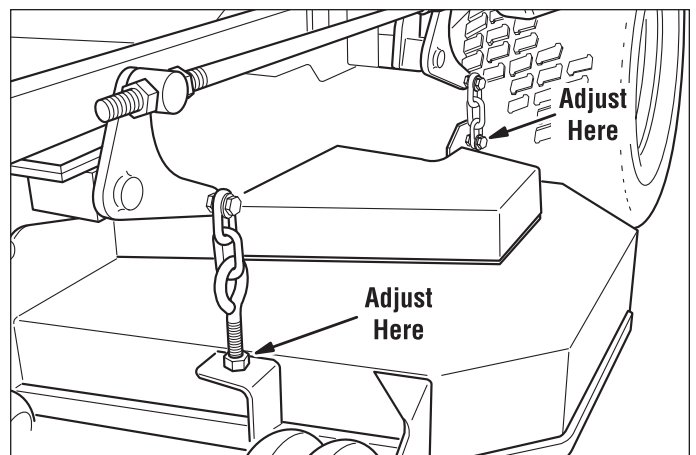

Figure 36. Hanger Chain Adjustment

Troubleshooting, Adjustment & Service

HYDRAULIC PUMP DRIVE BELT REPLACEMENT

1. Park the tractor on a smooth, level surface such as a concrete floor. Disengage the PTO, engage the parking brake, turn off the engine, and remove the ignition key.
2. Remove the PTO drive belt (see MOWER BELT REPLACEMENT for removal instructions).
3. Remove the hardware that secures the clutch anchor pad to the PTO clutch.
4. Loosen the nut towards the front of the machine on the spring anchor hook (G, Figure 37) to release the majority of the belt tension. Use caution and remove the nut to completely release the tension.
5. Remove the old belt and replace it with the new one. Make sure the V-side of the belt runs in the grooves of the crankshaft pulley and pump pulleys (B & C).
6. Reinstall the anchor hook (G) into the anchor tab and loosely fasten the nut. Adjust the anchor hook until a measurement of 8-3/8" (21,2 cm) is achieved from the outside of the spring hooks. Tighten nut.
7. Reinstall the clutch anchor pad to the PTO clutch and secure with the hardware previously removed.
8. Reinstall the PTO drive belt.

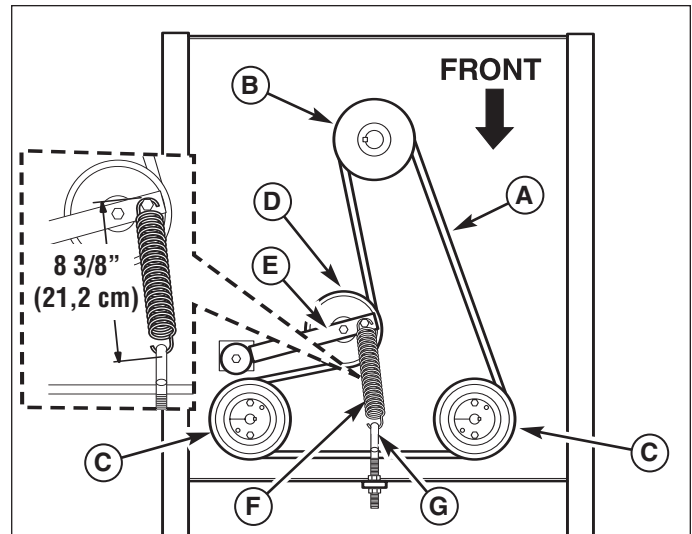

Figure 37. Hydraulic Pump Drive Belt Replacement

- A. Pump Drive Belt
- B. Crankshaft Pulley
- C. Pump Pulley
- D. Idler Pulley
- E. Idler Arm
- F. Spring
- G. Spring Anchor Hook

MOWER BELT REPLACEMENT



To avoid damaging belts, **DO NOT PRY BELTS OVER PULLEYS.**

1. Park the tractor on a smooth, level surface such as a concrete floor. Disengage the PTO, engage the parking brake, turn off the engine, and remove the ignition key.
2. Lower the mower deck to its lowest cutting position and remove the mower deck guards.
3. Using a 1/2" breaker bar, place the square end in the square hole located in the end of the idler arm (A, Figures 38). Carefully rotate the breaker bar clockwise, which will relieve the tension on the belt exerted from the idler arm.

WARNING

Use extreme caution when rotating the idler arm with the breaker bar, due to the increased tension in the spring as the idler arm is being rotated. Injury may result if the breaker bar is prematurely released while the spring is under tension.

4. Slide the drive belt over the edge of the stationary idler pulley (B). Carefully release the tension on the breaker bar.
5. Remove the old belt and replace with a new one. Make sure the V-side of the belt runs in the pulley grooves (Figure 39).
6. Install the drive belt on the PTO pulley, the spindle pulleys and all idler pulleys except the stationary pulley (B, Figure 38). Carefully rotate the breaker bar clockwise and install the belt on the stationary idler pulley (B). Carefully release the tension on the breaker bar.
7. Reinstall the mower deck guards.
8. Run the mower under no-load condition for about 5 minutes to break-in the new belt.

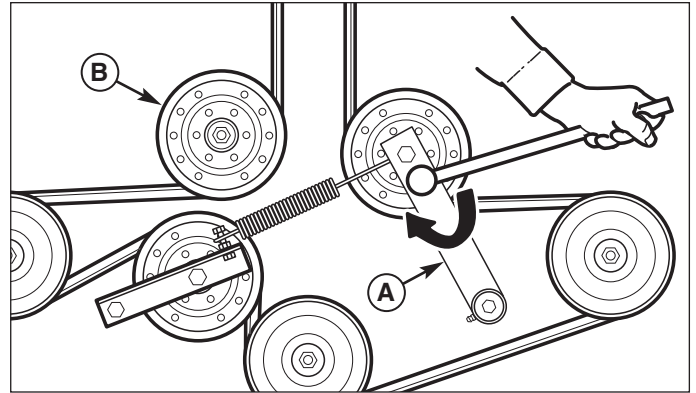

Figure 38. Mower PTO Belt
A. Idler Arm
B. Stationary Idler Pulley

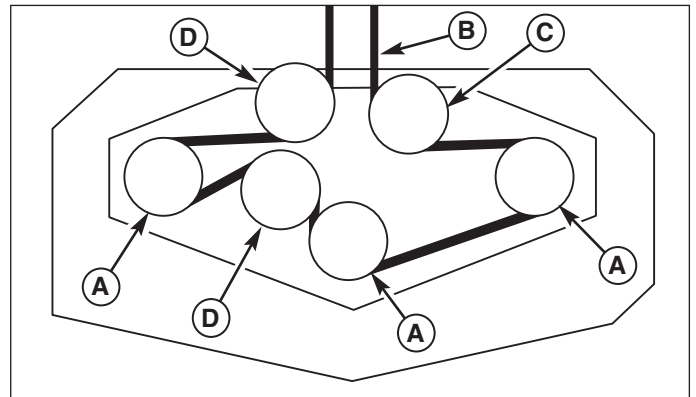

Figure 39. Mower PTO Belt Routing
A. Spindle Pulley
B. PTO Drive Belt
C. Spring-loaded Idler Pulley
D. Stationary Idler Pulley

Specifications



NOTE: Specifications are correct at time of printing and are subject to change without notice.

** Actual sustained equipment horsepower will likely be lower due to operating limitations and environmental factors.*

ENGINE:

21 HP* Briggs

Make	Briggs & Stratton
Model	385777
Horsepower	21 @ 3600 rpm
Displacement	38 Cu. in (628 cc)
Electrical System	12 Volt, 16 amp. Alternator, Battery: 340 CCA
Oil Capacity	3.6 US pt. (1.7 L) w/ Filter

23 HP* Briggs

Make	Briggs & Stratton
Model	386777
Horsepower	23 @ 3600 rpm
Displacement	38 Cu. in (628 cc)
Electrical System	12 Volt, 16 amp. Alternator, Battery: 340 CCA
Oil Capacity	3.6 US pt. (1.7 L) w/ Filter

CHASSIS:

Fuel Tank	Capacity: 6 Gallons (22.7 L)
Rear Wheels	Tire Size: 22 x 11.00 -10 Inflation Pressure: 15 psi (1,03 bar)
Front Wheels	Tire Size: 13 x 5.00 - 6 Inflation Pressure: 25 psi (1,72 bar)

TRANSMISSIONS:

HydroGear PG-3H / HGM-12C

Type	Pump and Wheel Motor
Hydraulic Fluid	Mobil 1™ 15W-50 synthetic oil or Castrol Syntec™ 5W-50 oil
Speeds	Forward: 0-10 MPH (0-16.09 km/h) Reverse: 0-5 MPH (0-8.05 km/h)
@ 3400 rpm	
Continuous Torque	222 ft. lbs. (301 Nm)
Output	
Maximum Weight on Axle	750 lbs. (340 Kg)

DIMENSIONS:

Overall Length	80" (203 cm)
Overall Width	61" (155 cm) - 48" models 65" (165 cm) - 52" models
Height	44" (112 cm)
Weight (apx..)	
With 48" Mower Deck	978 lbs. (444 kg)
With 52" Mower Deck	1012 lbs. (459 kg)