



Parts Manual



Conquest

4WD Series Garden Tractors & Mower Decks

23HP Product

Mfg. No.	Description
1695415	Conquest, 23HP B&S Hydro 4WD
2690679	Conquest, 23HP Hydro 4WD RMO and 50" Mower Deck (CE/Export)
2690744	Conquest, 23HP Hydro 4WD RMO and 50" Mower Deck

Mower Decks

Mfg. No.	Description
1695395	50" Mower Deck

PRODUCT COMPONENTS	PAGES
Frame & Front Axle Group - 4WD	4
Power Steering & Hydraulic Lift Group	8
Steering Group - Power Steering	10
Engine Group - 20HP, 22HP & 23HP Briggs & Stratton, Vanguard Twin	12
Transmission Group	14
Controls Group	18
Cruise Control Group	20
Electrical Group	22
Hood, Grille & Dash Group	26
Seat & Seat Deck Group	28
Lift Group - Manual Lift	30
Wheels & Tires Group	32
Decals Group	34
44" & 50" Mower Deck - Clutch & Support Group	36
50" Mower Deck - Height Adjustment & Roller Bar Group	38
50" Mower Deck - Height Adjustment & Roller Bar Group	40
50" Mower Deck - Housing, Arbors & Blades Group	44
50" Mower Deck - Housing, Arbors & Blades Group	48
Torque Specification Chart	Inside Back Cover

Frame & Front Axle Group - 4WD

987590

NOTE: Unless noted otherwise,
use the standard hardware torque
specification chart.

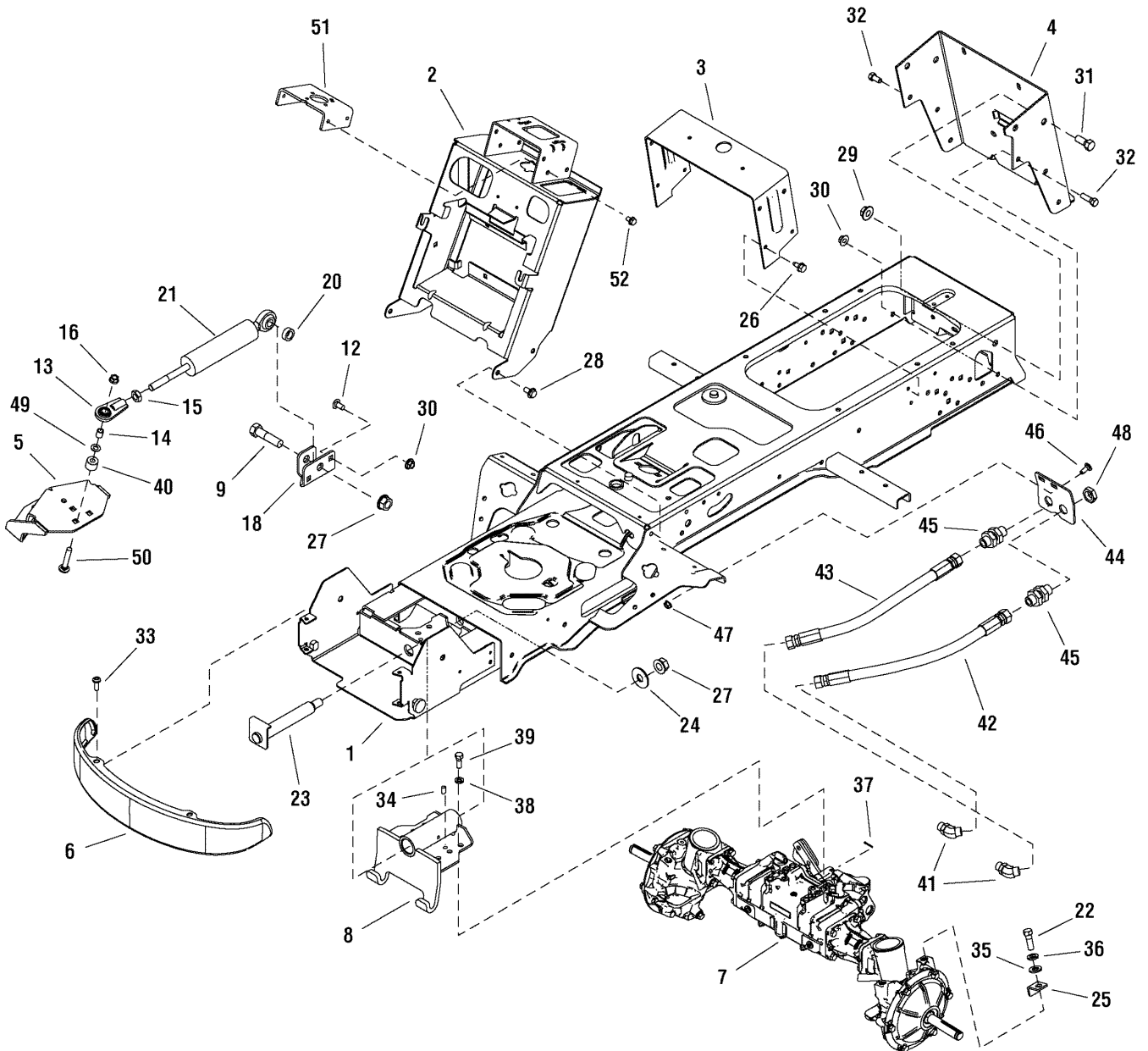

The above parts group applies to the following Mfg. Nos.:

1695415 - Conquest

2690679 - Conquest

2690744 - Conquest

Frame & Front Axle Group - 4WD

REF NO	PART NO.	QTY.	DESCRIPTION
1	1734731ASM	1	FRAME ASSEMBLY, Front & Rear 4WD
2	1733139ASM	1	TOWER & SUPPORT ASSEMBLY
3	1723528ASM	1	SUPPORT, Seat Deck
4	1722602ASM	1	BACKPLATE, Hitch
5	1733918ASM	1	BRACKET ASSEMBLY, Steering 4WD
6	1721805ASM	1	BUMPER, 4GA
7	1733480SM	1	AXLE ASSEMBLY, Front
8	1734241ASM	1	PIVOT ASSEMBLY, Axle w/Bushings
9	1960755SM	1	CAPSCREW, Hex Head, 5/8-11 x 2-1/2 G5
12	1931348SM	2	CARRIAGE BOLT, 3/9-16 x 3/4 G5
13	1702779SM	1	JOINT, Ball 1/2-20
14	1708236SM	1	SPACER
15	1919262SM	1	NUT, Hex Jam, 1/2-20
16	1930645SM	1	NUT, Hex Flange, 3/8-16 Two-Way Lock
18	1733166ASM	1	BRACKET, Cylinder Mounting
20	2172914SM	1	SPACER
21	1733759SM	1	CYLINDER, Hydraulic Steering
22	197487SM	3	CAPSCREW, Hex Head, M12-1-3/4 x 35
23	1733863SM	1	SHAFT & BRACKET ASSEMBLY, Axle Pivot
24	1960035SM	2	WASHER, 5/8
25	1734511ASM	1	STOP, "L" Steering
26	1664847SM	4	SCREW, Hex Washer Head Taptite, 5/16-18 x 3/4
27	2860646SM	2	NUT, Hex Flange 5/8-11 Two-Way Lock
28	1923683SM	4	SCREW, Hex Washer head, Taptite, 3/8-16 x 3/4
29	2860668SM	2	NUT, Hex Flange 1/2-13 Whiz Lock
30	1928352SM	4	NUT, Hex Flange 3/8-16 Whiz Lock
31	1923114SM	2	CAPSCREW, Hex Head 1/2-13 x 1 G5
32	1921210SM	2	CAPSCREW, Hex Head 3/8-16 x 1 G5
33	1960086SM	4	SCREW, Truss Head Torx Drive 5/16-18 x 7/8
34	1733581SM	2	PIN, Dowel
35	1960170SM	3	WASHER, 1/2
36	1916966SM	3	LOCKWASHER, Spring
37	1923360SM	1	PIN, Cotter
38	1960754SM	6	LOCKWASHER, Spring
39	1950036SM	6	CAPSCREW, Hex Head
40	1667812SM	1	SPACER, Powdered Metal
41	1733403SM	2	FITTING, Hose Elbow, 45 Degrees, 13/16-16 x 3/4-16
42	1733400SM	1	HOSE ASSEMBLY, Hydraulic
43	1733891SM	1	HOSE ASSEMBLY, Hydraulic
44	1733501ASM	1	BRACKET, Hose Mounting 10GA
45	1733402SM	2	FITTING, Bulkhead Union 13/16-16
46	1931333SM	2	CARRIAGE BOLT, 5/16-18 x 3/4 G5
47	1960636SM	2	NUT, Hex KEPS, 5/16-18
48	1733947SM	2	NUT, Jam 13/16-16

Footnotes

The above parts group applies to the following Mfg. Nos.:

1695415 - Conquest

2690679 - Conquest

2690744 - Conquest

Frame & Front Axle Group - 4WD

987590

NOTE: Unless noted otherwise,
use the standard hardware torque
specification chart.

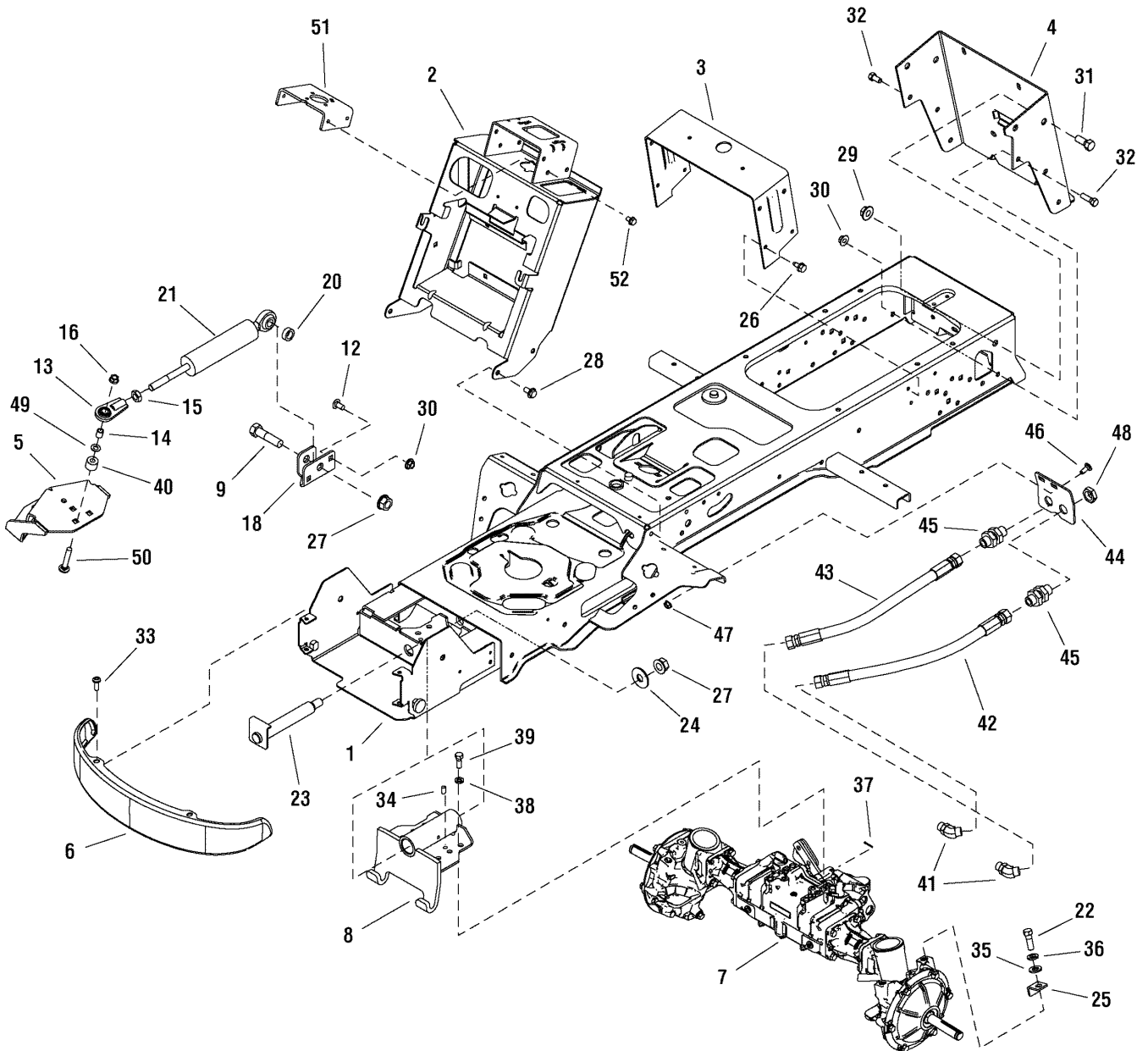

The above parts group applies to the following Mfg. Nos.:

1695415 - Conquest

2690679 - Conquest

2690744 - Conquest

Frame & Front Axle Group - 4WD

REF NO	PART NO.	QTY.	DESCRIPTION
49	1960103SM	1	WASHER, 3/8
50	1931355SM	1	CARRIAGE BOLT, 3/8-16 x 2-1/4 G5
51	1733044ASM	1	SUPPORT, Steering Unit 7GA
52	1924856SM	4	SCREW, Hex Washer Head Taptite 5/16-18 x 1/2

Footnotes

The above parts group applies to the following Mfg. Nos.:

1695415 - Conquest

2690679 - Conquest

2690744 - Conquest

Power Steering & Hydraulic Lift Group

987528

NOTE: Unless noted otherwise,
use the standard hardware torque
specification chart.

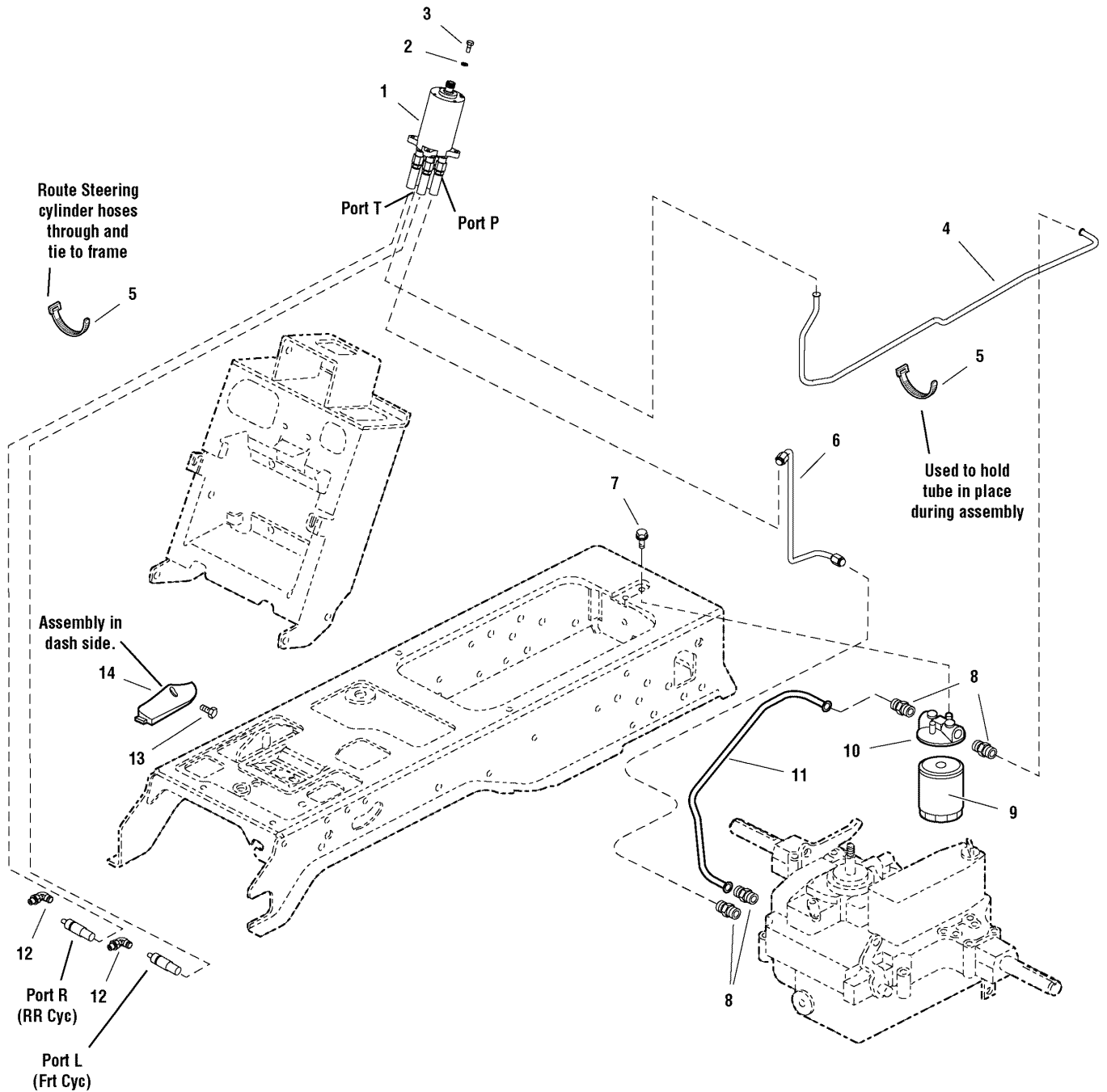

The above parts group applies to the following Mfg. Nos.:

1695415 - Conquest

2690679 - Conquest

2690744 - Conquest

Power Steering & Hydraulic Lift Group

REF NO	PART NO.	QTY.	DESCRIPTION
1	1733582SM	1	POWER STEERING ASSEMBLY
1	1733894SM	1	POWER STEERING ASSEMBLY (Used only on 4WD models)
2	1916964SM	4	LOCKWASHER, Spring
3	2860444SM	4	CAPSCREW, Hex Head
4	1722138SM	1	TUBE, Hydraulic
5	2825094SM	2	TIE, Self Locking
6	1733727SM	1	TUBE, Hydraulic
7	1931646SM	2	SCREW, Hex Whiz Lock Flange 1/4-20 x 1/2
8	1722123SM	4	FITTING, Straight
9	1719168SM	1	FILTER, Oil
10	1719169SM	1	BASE, Oil Filter
11	1722297SM	1	TUBE, Hydraulic
11	1733427SM	1	TUBE, Hydraulic (Used only on 4WD models)
12	1733230SM	2	FITTING, Hose Elbow Perma Push 9/16-18
13	1722607SM	1	SCREW, Round Head Plastite (Used only on 4WD models)
14	1722285SM	1	COVER, Lift (Used only on 4WD models)

Footnotes

The above parts group applies to the following Mfg. Nos.:

1695415 - Conquest

2690679 - Conquest

2690744 - Conquest

Steering Group - Power Steering

987424

NOTE: Unless noted otherwise,
use the standard hardware torque
specification chart.

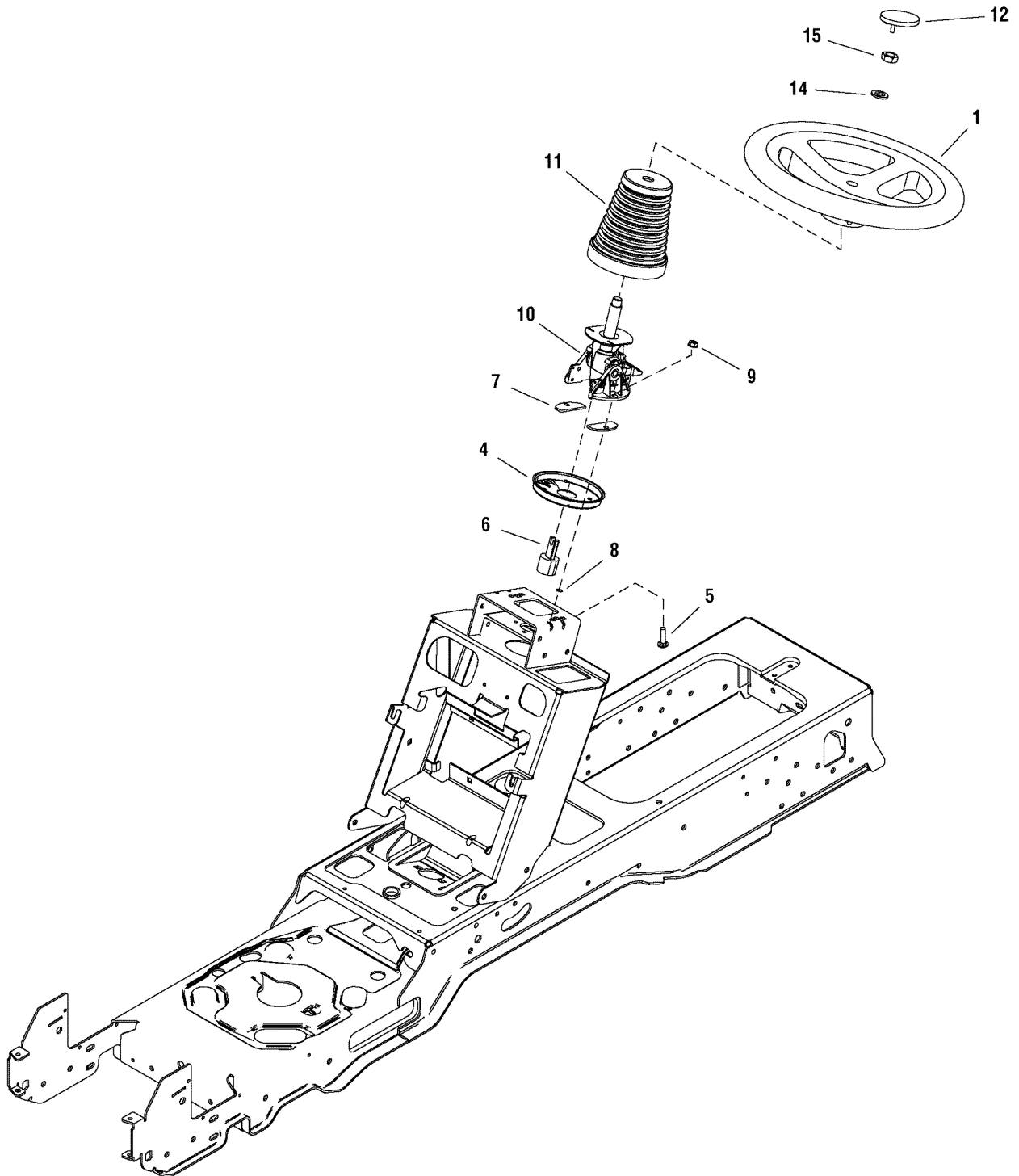

The above parts group applies to the following Mfg. Nos.:

1695415 - Conquest

2690679 - Conquest

2690744 - Conquest

Steering Group - Power Steering

REF NO	PART NO.	QTY.	DESCRIPTION
1	1733363SM	1	STEERING WHEEL
4	1724685ASM	1	PLATE, Steering Mounting
5	1960655SM	2	CARRIAGE BOLT, 5/16-18 x 1-1/4 G5
6	1725294SM	1	ADAPTER, Tilt
7	1723898SM	2	SPACER
8	1933988SM	2	NUT, Push Pal
9	1960636SM	2	NUT, Hex Keps 5/16-18
10	1733790SM	1	STEERING UNIT, Tilt
11	1686970SM	1	BELLOWS, Tilt Steering Unit w/Slot
12	1725024SM	1	CAP, Steering Wheel
13	1716518SM	2	DECAL, Power Steering (Not Shown)
14	1924366SM	1	WASHER, 5/8
15	1960576SM	1	NUT, Hex Lock ESNA Light 5/8-18

Footnotes

The above parts group applies to the following Mfg. Nos.:

1695415 - Conquest
2690679 - Conquest
2690744 - Conquest

Engine Group - 20HP, 22HP & 23HP Briggs & Stratton, Vanguard Twin

986651

NOTE: Unless noted otherwise,
use the standard hardware torque
specification chart.

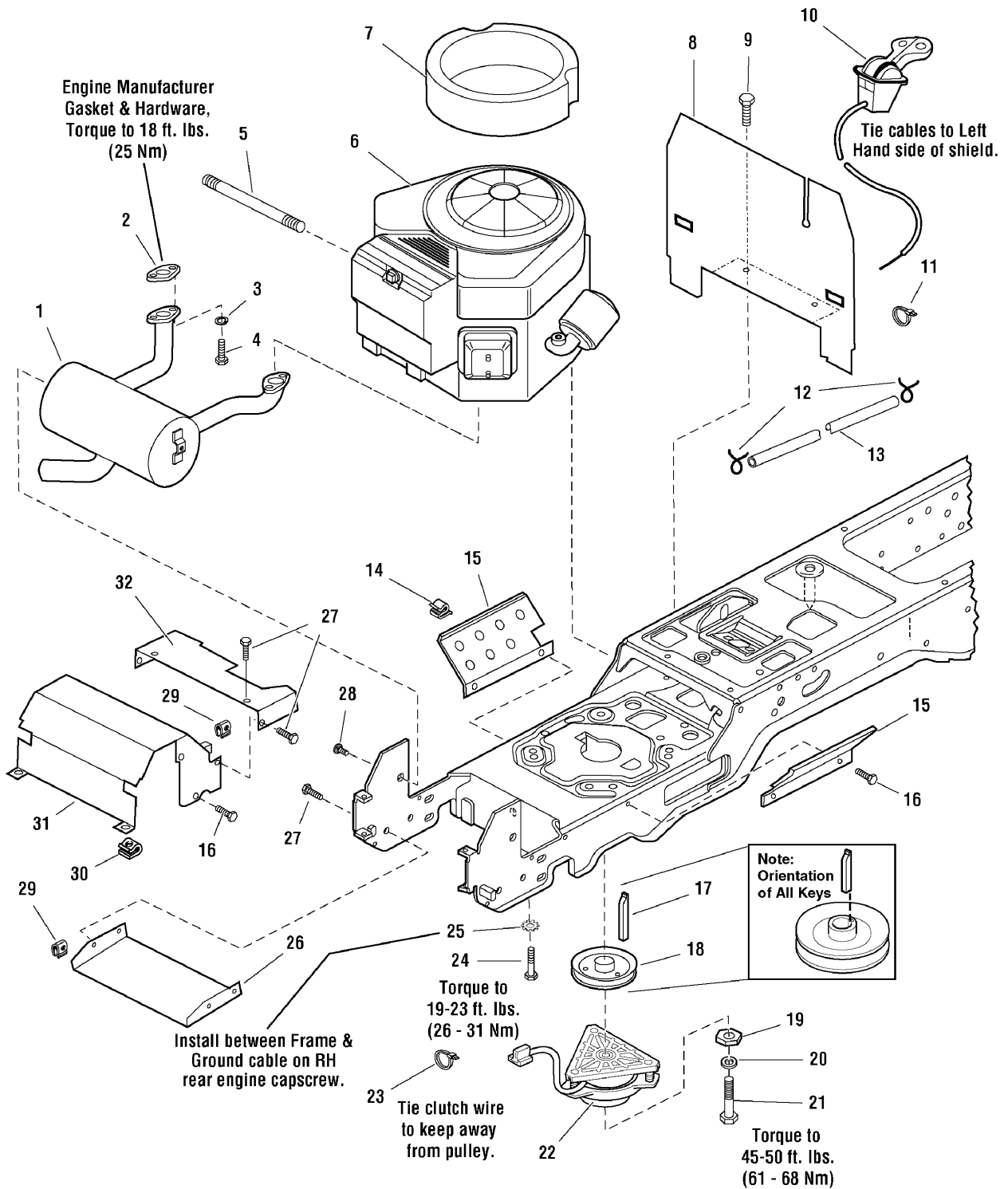

The above parts group applies to the following Mfg. Nos.:

- 1695415 - Conquest
- 2690679 - Conquest
- 2690744 - Conquest

Engine Group - 20HP, 22HP & 23HP Briggs & Stratton, Vanguard Twin

REF NO	PART NO.	QTY.	DESCRIPTION
1	1726920SM	1	MUFFLER
1	1722625SM	1	MUFFLER (Only used on 20HP Models)
2	*	2	GASKET
3	1917356SM	4	LOCKWASHER, 5/16
4	2860660SM	4	CAPSCREW, Socket Head, 5/16-18 x 7/8, G8
5	1723165SM	1	HOSE, Oil Drain
6	*	1	ENGINE, 22HP Briggs & Stratton VANGUARD Twin, Model 386777, Type 0111E1
6	*	1	ENGINE, 23HP Briggs & Stratton VANGUARD Twin, Model 386777, Type 0111E1
6	*	1	ENGINE, 21HP Briggs & Stratton VANGUARD Twin, Model 385777, Type 0119-E1
6	*	1	ENGINE, 20HP Briggs & Stratton VANGUARD Twin, Model 358777, Type 0110-E1
7	1722949SM	1	SEAL, Circle
8	1722388ASM	1	BULKHEAD
9	1925003SM	2	CAPSCREW, Hex Head Taptite, 1/4-20 x 1/2
10	1727223SM	1	CONTROL, Throttle Double 39" Long w/Knobs (Only used on 20HP Models)
10	1734506SM	1	CONTROL, Throttle Double
11	1701011SM	1	TIE
12	2860112SM	2	CLAMP, Hose Type E
13	1718678SM	1	HOSE, 59" Long
14	2834683SM	2	CLIP, Wire
15	1722392ASM	2	SHIELD
16	1929000SM	8	SCREW, Hex Head Taptite, 1/4-20 x 3/8
17	1720463SM	1	KEY
18	1722288SM	1	PULLEY & HUB ASSEMBLY, 4-1/2 OD
19	1708264SM	1	WASHER, Hex
20	1918199SM	1	LOCKWASHER, 7/16
21	1960648SM	1	CAPSCREW, Hex Head, 7/16-20 x 2-3/4
22	1686883SM	1	CLUTCH, Electric, OGURA
22	1720532SM	1	CLUTCH, Electric, Big Brake OGURA
23	2832747SM	1	TIE
24	2830598SM	4	CAPSCREW, Hex Head Taptite, 3/8-16 x 1-1/2
25	2820427SM	1	LOCKWASHER, External Tooth, 3/8
26	1722414ASM	1	SHIELD, Muffler Bottom
27	1960295SM	8	CAPSCREW, Hex Head Flange Lock, 1/4-20 x 5/8
28	1924856SM	2	CAPSCREW, Hex Head Taptite, 5/16-18 x 1/2
29	1960368SM	8	NUT, Speed, 1/4-20
30	1935255SM	2	NUT, Speed, 5/16-18
31	1722389ASM	1	DUCT, Muffler Top
32	1722390ASM	1	DUCT, Muffler Extension

Footnotes

Note* See your local Briggs & Stratton distributor for parts and service.

The above parts group applies to the following Mfg. Nos.:

1695415 - Conquest
2690679 - Conquest
2690744 - Conquest

Transmission Group

REF NO	PART NO.	QTY.	DESCRIPTION
1	1733478SM	1	TRANSMISSION ASSEMBLY, K664
2	1722194SM	1	PULLEY & HUB ASSEMBLY
3	1719233SM	1	FAN
4	1933958SM	3	SCREW, Hex Washer Head, Taptite, 1/4-20 x 1-1/4
5	1721392SM	1	BELT, 94.05
6	1721593ASM	1	STRAP, 4-1/4 Long
7	1733318ASM	1	ARM, Control 7GA
8	1721424SM	1	ROD, 17-27/64 Long
9	1722684SM	1	SPRING, Compression
10	1729277SM	1	SPRING, Compression
11	1722711SM	1	CAP, Expansion
12	1960676SM	2	SCREW, Pan Head Torx, 1/4-20 x 1-1/4 Taptite
13	1704351SM	15	FASTENER, Panel
14	1722174SM	1	PAD, Footrest L.H.
15	1722173SM	1	PAD, Footrest R.H.
16	1721622SM	1	ROD, Free Wheel
17	1723126SM	1	KNOB, Interior Thread
18	1721728ASM	2	SUPPORT, Transmission
19	1733531SM	1	HOSE, Hydraulic
21	1732129SM	3	BOLT, Shoulder, 3/8-16
22	1960074SM	1	CLIP, Hair Pin
23	1734337SM	1	SPACER
24	2860266SM	1	CLAMP, Hose Worm
25	1960027SM	3	WASHER, 1/2
26	1924940SM	1	WASHER, 3/8
27	1722460SM	1	PIN, Quick
28	1732989SM	1	TANK, Oil Natural
29	1723214SM	2	CLAMP, Hose Worm
30	1960686SM	6	NUT, Hex Flange 5/16-18 ESNA
31	1918447SM	1	COTTER PIN
32	1921719SM	1	CAPSCREW, Hex Head 5/16-18 x 2-1/2 G5
33	1960141SM	1	WASHER, 5/16
34	1931335SM	1	CARRIAGE BOLT, 5/16-18 x 1 G5
35	1960636SM	2	NUT, Hex KEPS 5/16-18
36	1719968SM	1	NUT, Hex Flange
42	1960687SM	4	NUT, Hex Flange 3/8-16 ESNA
43	1918267SM	1	WASHER, 7/16
44	1931350SM	6	CARRIAGE BOLT, 3/8-16 x 1 G5
45	1960590SM	4	CAPSCREW, Hex Head 5/16-18 x 3 G5
46	1919326SM	3	WASHER, 5/16
47	1960637SM	6	NUT, Hex Keps 3/8-16
48	1727215ASM	1	ACTUATOR, Switch
49	1960241SM	2	POP RIVET
50	1724107SM	1	PIN, Clevis

Footnotes

The above parts group applies to the following Mfg. Nos.:

1695415 - Conquest

2690679 - Conquest

2690744 - Conquest

Transmission Group

987547

NOTE: Unless noted otherwise,
use the standard hardware torque
specification chart.

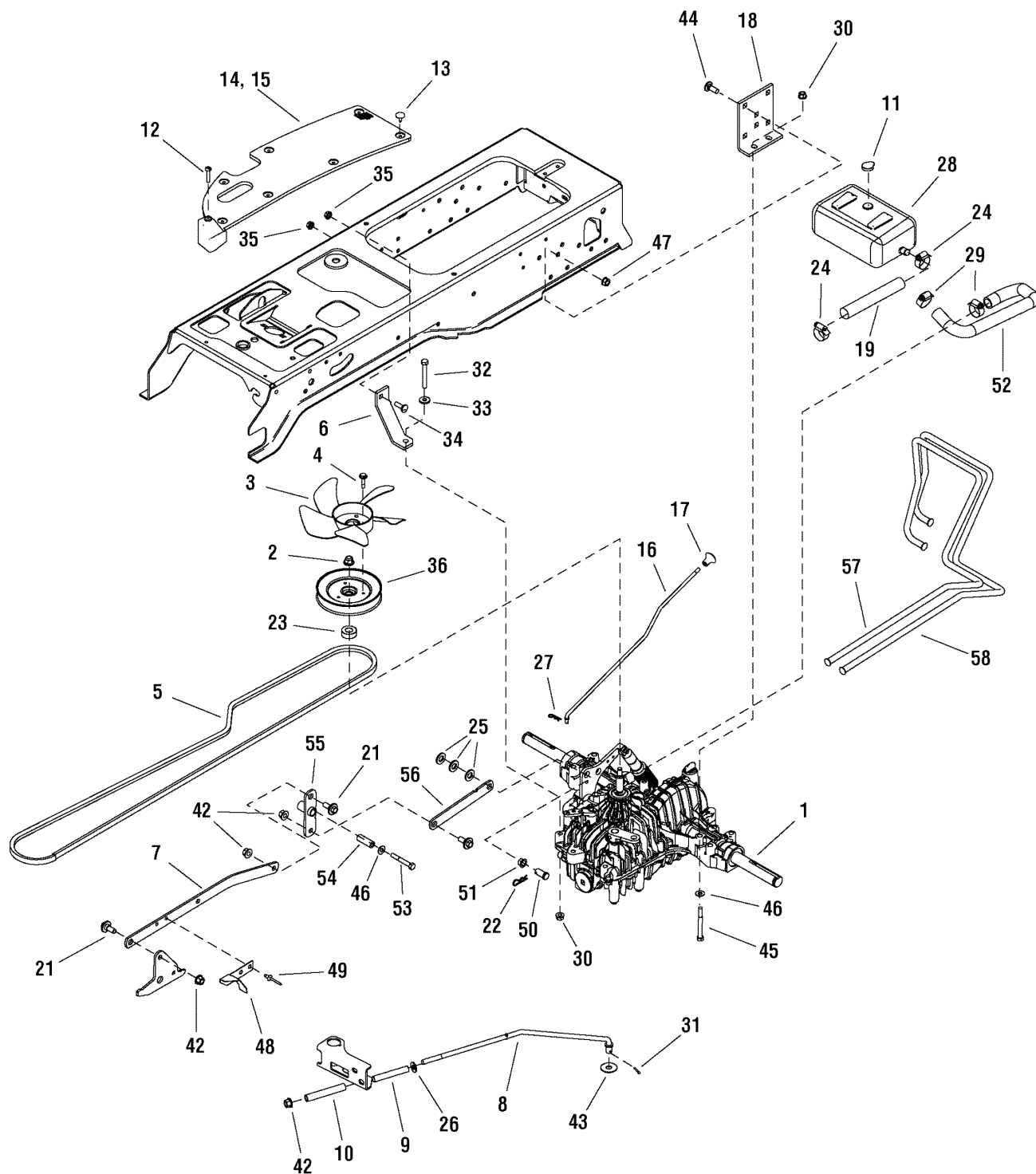

The above parts group applies to the following Mfg. Nos.:

- 1695415 - Conquest
- 2690679 - Conquest
- 2690744 - Conquest

Transmission Group

REF NO	PART NO.	QTY.	DESCRIPTION
51	1722648SM	1	BEARING
52	1722468SM	1	HOSE, Hydraulic
53	1921160SM	1	CAPSCREW, Hex Head, 5/16-18 x 2-1/4 G5
54	1713588SM	1	SPACER
55	1733320ASM	1	PIVOT ASSEMBLY, Control
56	1733525ASM	1	ARM, Control
57	1733483SM	1	TUBE, Hydraulic 4WD
58	1733484SM	1	TUBE, Hydraulic Rear

Footnotes

The above parts group applies to the following Mfg. Nos.:

1695415 - Conquest

2690679 - Conquest

2690744 - Conquest

Controls Group

986599

NOTE: Unless noted otherwise,
use the standard hardware torque
specification chart.

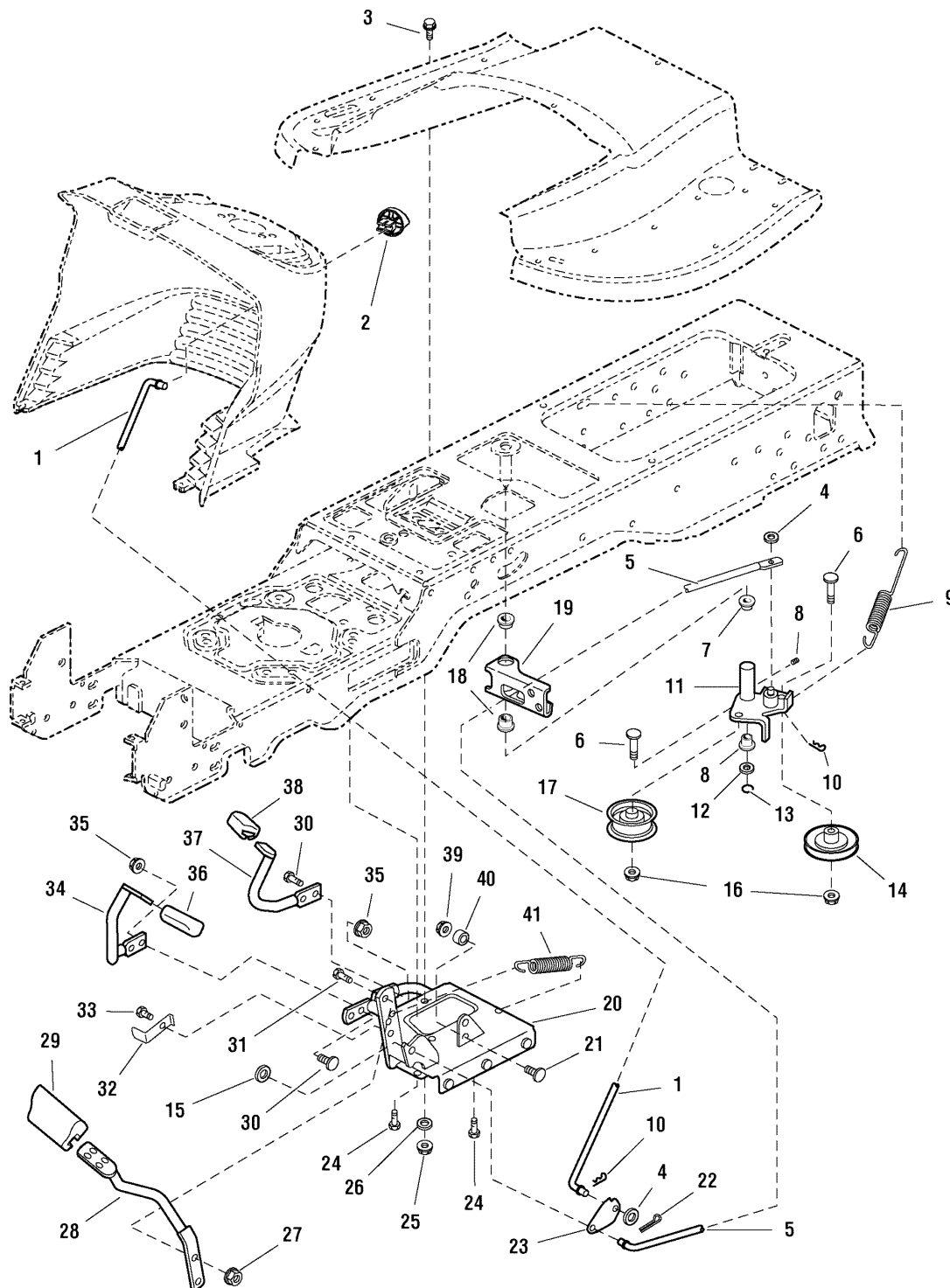

The above parts group applies to the following Mfg. Nos.:

1695415 - Conquest

2690679 - Conquest

2690744 - Conquest

Controls Group

REF NO	PART NO.	QTY.	DESCRIPTION
1	1721353SM	1	ROD, Brake Lock
2	1721891SM	1	KNOB, Push On, Red Plastic "P"
3	1930591SM	1	CAPSCREW, Hex Flange Whiz Lock, 5/16-18 x 3/4
4	1919326SM	2	WASHER, 5/16, Black
5	1721476SM	1	ROD, Brake
6	1931353SM	2	CARRIAGE BOLT, 3/8-16 x 1 3/4
7	1663114SM	2	BUSHING, 5/8 x 3/4 x 3/4, Nylon
8	2821133SM	1	FITTING, Lube, 1/4
9	1725250SM	1	SPRING, Extension
10	1722460SM	3	PIN, Quick
11	1724917SM	1	ARM & HUB ASSEMBLY, Idler
12	1960020SM	1	WASHER, 5/8
13	1704420SM	1	RING, Clipping Extension
14	1721134SM	1	PULLEY, w/Bearing
15	1924940SM	1	WASHER, 3/8
16	1960687SM	2	NUT, Hex Flange ESNA, 3/8-16
17	1721133SM	1	PULLEY, Idler
18	1723237SM	2	BUSHING, 1 x 1-1/8 x 5/8, Nylon
19	1722513SM	1	ARM, Brake
20	1726763SM	1	PEDAL ASSEMBLY, Foot
21	1931320SM	1	CARRIAGE BOLT, 1/4-20 x 1-1/4
22	1918447SM	1	PIN, Cotter, Black
23	1721354ASM	1	LATCH, Brake
24	1664847SM	3	CAPSCREW, Hex Washer Head Taptite, 5/16-18 x 3/4
25	1919438SM	1	NUT, Hex Lock ESNA Light, 5/16-18
26	1919381SM	1	WASHER, 5/16, Black
27	1927557SM	2	NUT, Hex Flange Whiz Lock Large, 5/16-18
28	1722535ASM	1	PEDAL, Brake
29	1721577SM	1	PAD, Brake Pedal
30	1931334SM	4	CARRIAGE BOLT, 5/16-18 x 7/8
31	1921333SM	2	CAPSCREW, 5/16-18 x 1
32	1722083ASM	1	ACTUATOR, Switch 2.53" Long
33	1923683SM	1	CAPSCREW, Hex Washer Head Taptite, 3/8-16 x 3/4
34	1722070ASM	1	PEDAL, Forward
35	1960636SM	4	NUT, Hex KEPS, 5/16-18
36	1721675SM	1	PAD, Foot Pedal Forward
37	1722071ASM	1	PEDAL, Reverse
38	1721674SM	1	PAD, Foot Pedal Reverse
39	1920397SM	1	NUT, Hex Lock ESNA Light, 1/4-20
40	1686612SM	1	CAM, Roller
41	1721995SM	1	SPRING, Extension

Footnotes

The above parts group applies to the following Mfg. Nos.:

1695415 - Conquest
2690679 - Conquest
2690744 - Conquest

Cruise Control Group

REF NO	PART NO.	QTY.	DESCRIPTION
1	1722314SM	1	COVER, w/Cruise Icon
2	1960666SM	1	SCREW, Torque Head Plus Socket Head, 1/4-20 x 7/8
3	1722303SM	1	KNOB, Cruise
4	1920397SM	1	NUT, Hex Lock ESNA Light, 1/4-20
5	1722003SM	1	LEVER & BRACKET ASSEMBLY, Cruise
6	1960103SM	2	WASHER, 3/8, Black
7	1931333SM	1	CARRIAGE BOLT, 5/16-18 x 3/4
8	1924361SM	2	WASHER, 1/2
9	1709043SM	1	SPACER, w/Flange, 11/32 x 15/32 x 3/4
10	1931342SM	1	CARRIAGE BOLT, 5/16-18 x 2-3/4
11	1960273SM	1	CARRIAGE BOLT, 5/16-18 x 2-1/4
12	1722460SM	2	PIN, Quick
13	1722117SM	1	ROD, Cruise
14	1733719SM	1	ROD, Return
15	2159106SM	1	SPRING, Cruise Return to Frame
16	1960636SM	2	NUT, Hex KEPS, 5/16-18
17	1960001SM	2	CAPSCREW, Hex Washer Head Plastite, 10-14 x 5/8
18	1717050SM	1	SWITCH, Push, Neutral Start, Gray
19	1722080SM	1	SPACER, 11/32 x 5/8 x 1-13/32
20	1919326SM	1	WASHER, 5/16, Black
21	1919381SM	1	WASHER, 5/16, Black
22	1919438SM	1	NUT, Hex Lock ESNA Light, 5/16-18
23	1677746SM	1	SPRING, Compression
24	1918447SM	1	PIN, Cotter

Footnotes

The above parts group applies to the following Mfg. Nos.:

1695415 - Conquest
2690679 - Conquest
2690744 - Conquest

Electrical Group

986605

NOTE: Unless noted otherwise, use the standard hardware torque specification chart.

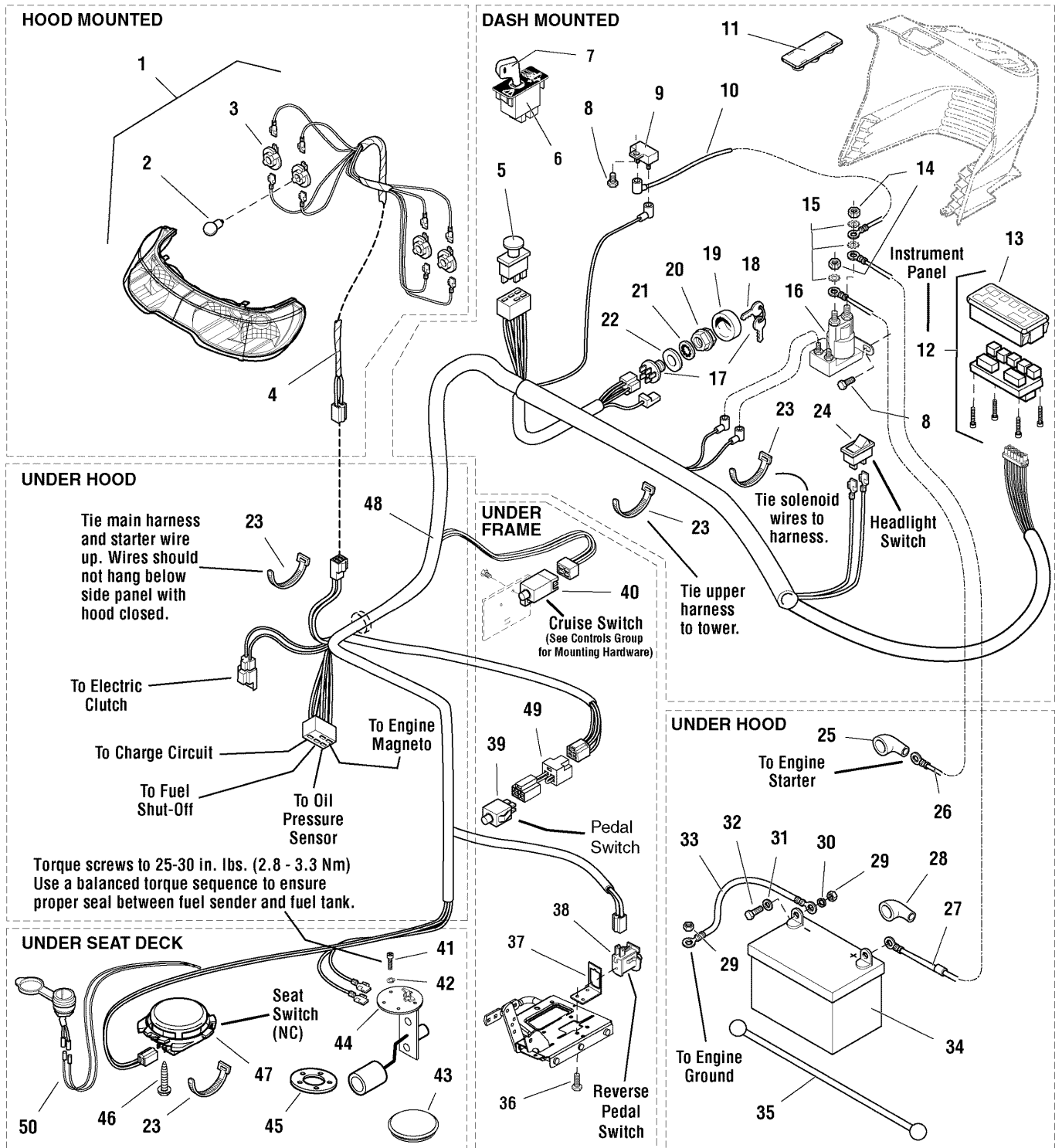

The above parts group applies to the following Mfg. Nos.:

- 1695415 - Conquest
- 2690679 - Conquest
- 2690744 - Conquest

Electrical Group

REF NO	PART NO.	QTY.	DESCRIPTION
1	1721810SM	1	HEADLIGHT ASSEMBLY, 4 Bulb (Includes Ref. Nos. 2 & 3)
2	1677371SM	4	BULB, Headlight, 12.8V
3	1723451SM	4	SOCKET ASSEMBLY, Headlight, Sealed
4	1722669SM	1	HARNESS, Headlight
5	1722887SM	1	SWITCH, PTO Push/Pull Symbols
6	1726556SM	1	MODULE, RMO (Includes Ref. No. 7)
7	1726557SM	1	KEY, RMO Module Plastic
8	1925003SM	2	CAPSCREW, Hex Washer Head Taptite, 1/4-20 x 1/2, Black
9	1665238SM	1	BREAKER, Circuit, 12 Volt 20 Amps
10	1665237SM	1	WIRE, 12GA 5-15/16 Long, Red
11	1722611SM	1	PLUG, Hole, Square
12	1725074SM	1	PANEL, Instrument w/ Fuel Gage & Hour Meter (Includes Ref. No. 13)
13	1724865SM	1	COVER, Instrument Panel
14	2820263SM	2	NUT, Hex, 5/16-24
14	2860750SM	2	NUT, KEPS Lock 5/16-24 (CE/Export) (Used only on RMO/ACS Models)
15	2820426SM	3	LOCKWASHER, External Tooth, 5/16
16	1722739SM	1	SOLENOID
16	1728963SM	1	SOLENOID (CE/Export) (Used only on RMO/ACS Models)
17	1686734SM	1	SWITCH ASSEMBLY, Ignition, 6 Pin INDAK (Includes Ref. Nos. 18, 19, 20, 21 & 22)
18	1717163SM	1	KEYS, Set of 2
19	1717550SM	1	COVER, For Ignition Switch, Plastic
20	1717549SM	1	NUT, Hex Flange, 5/8-32, Ignition Switch
21	1960547SM	1	LOCKWASHER, Internal Tooth, 5/8, Thin
22	2101025SM	1	WASHER, Shim
23	1701011SM	3	TIE, Strap, 7-5/16 Long
23	2825094SM	4	TIE, Strap, 7-5/16 Long (CE/Export) (Used only on RMO/ACS Models)
24	1716951SM	1	SWITCH, Headlights , 2 Terminal
25	1713535SM	1	BOOT, Insulator Cable Terminal, 1-15/16 Long, Red
26	1721830SM	1	CABLE, #6 x 25" Long, Ring Terminals
27	1603618SM	1	CABLE, #6 x 8" Long, Ring Terminals
28	1677296SM	1	BOOT, Insulator Battery Terminal
29	2816622SM	3	NUT, Hex, 1/4-20
30	2816964SM	2	LOCKWASHER, 1/4
31	2821319SM	2	WASHER, 1/4
32	2823341SM	2	CAPSCREW, Hex Head, 1/4-20 x 3/4
33	1713163SM	1	CABLE, #6 x 26 Long, Ring Terminal
34	1685215SM	1	BATTERY, 12 Volt
35	1722009SM	1	STRAP, Battery, 14 Long, Rubber
36	1929000SM	2	CAPSCREW, Hex Head Taptite, 1/4-20 x 3/8
37	1726810ASM	1	BRACKET, Switch Mount
38	1732004SM	1	SWITCH, Reverse Pedal
38	1704379SM	1	SWITCH, Reverse Pedal (CE/Export) (Used only on RMO/ACS Models)
39	1732006SM	1	SWITCH, Push Button, Foot Pedal
40	1717050SM	1	SWITCH, Cruise Control, Grey, NO (Used on all models except CE/Export)

Footnotes

The above parts group applies to the following Mfg. Nos.:

1695415 - Conquest

2690679 - Conquest

2690744 - Conquest

Electrical Group

986605

NOTE: Unless noted otherwise, use the standard hardware torque specification chart.

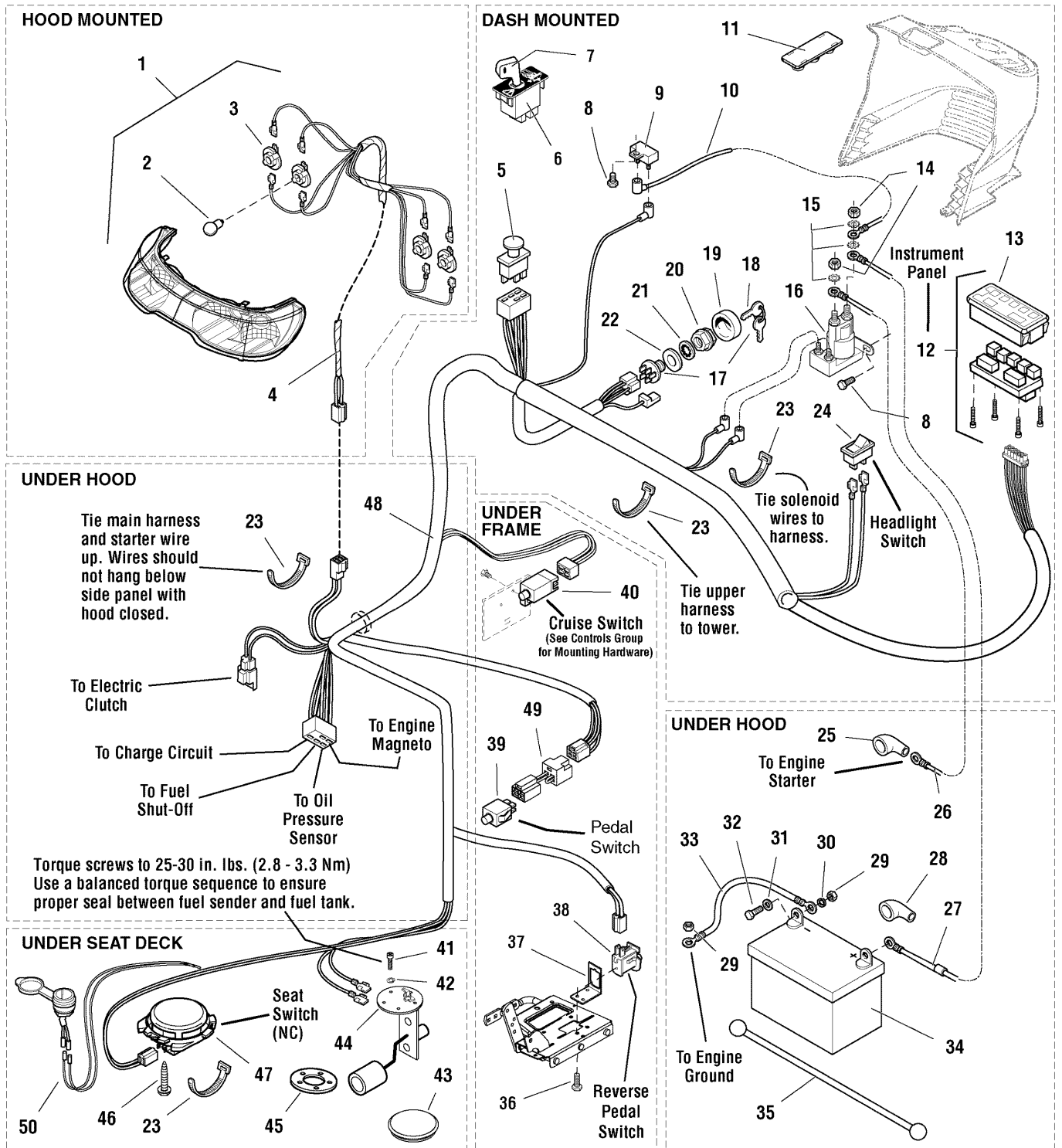

The above parts group applies to the following Mfg. Nos.:

- 1695415 - Conquest
- 2690679 - Conquest
- 2690744 - Conquest

Electrical Group

REF NO	PART NO.	QTY.	DESCRIPTION
41	2860665SM	5	SCREW, Pan Head Torx, #10-32 x 1/2
42	1917365SM	5	LOCKWASHER, 3/16 #10
43	1722309SM	1	PLUG, Hole 3", Round
44	1686921SM	1	SENDER, Fuel Tank (Includes Ref. 45)
45	1685303SM	1	GASKET
46	1960536SM	2	CAPSCREW, Hex Washer Head Plastite, 1/4 x 1/2
47	1716368SM	1	SWITCH, Seat, Grey, NC
47	1718981SM	1	SWITCH, Seat, Grey, NC (CE/Export) (Used only on RMO/ACS Models)
48	1730192SM	1	HARNESS, Wiring
48	1733220SM	1	HARNESS, Wiring (CE/Export) (Used only on RMO/ACS Models)
49	1734025SM	1	WIRING ASSEMBLY, All Conditions Shutdown (CE/Export) (Used only on RMO/ACS Models)
50	1725302SM	1	12-VOLT OUTLET (CE/Export) (Used only on RMO/ACS Models)

Footnotes

The above parts group applies to the following Mfg. Nos.:

1695415 - Conquest

2690679 - Conquest

2690744 - Conquest

Hood, Grille & Dash Group

986608

NOTE: Unless noted otherwise,
use the standard hardware torque
specification chart.

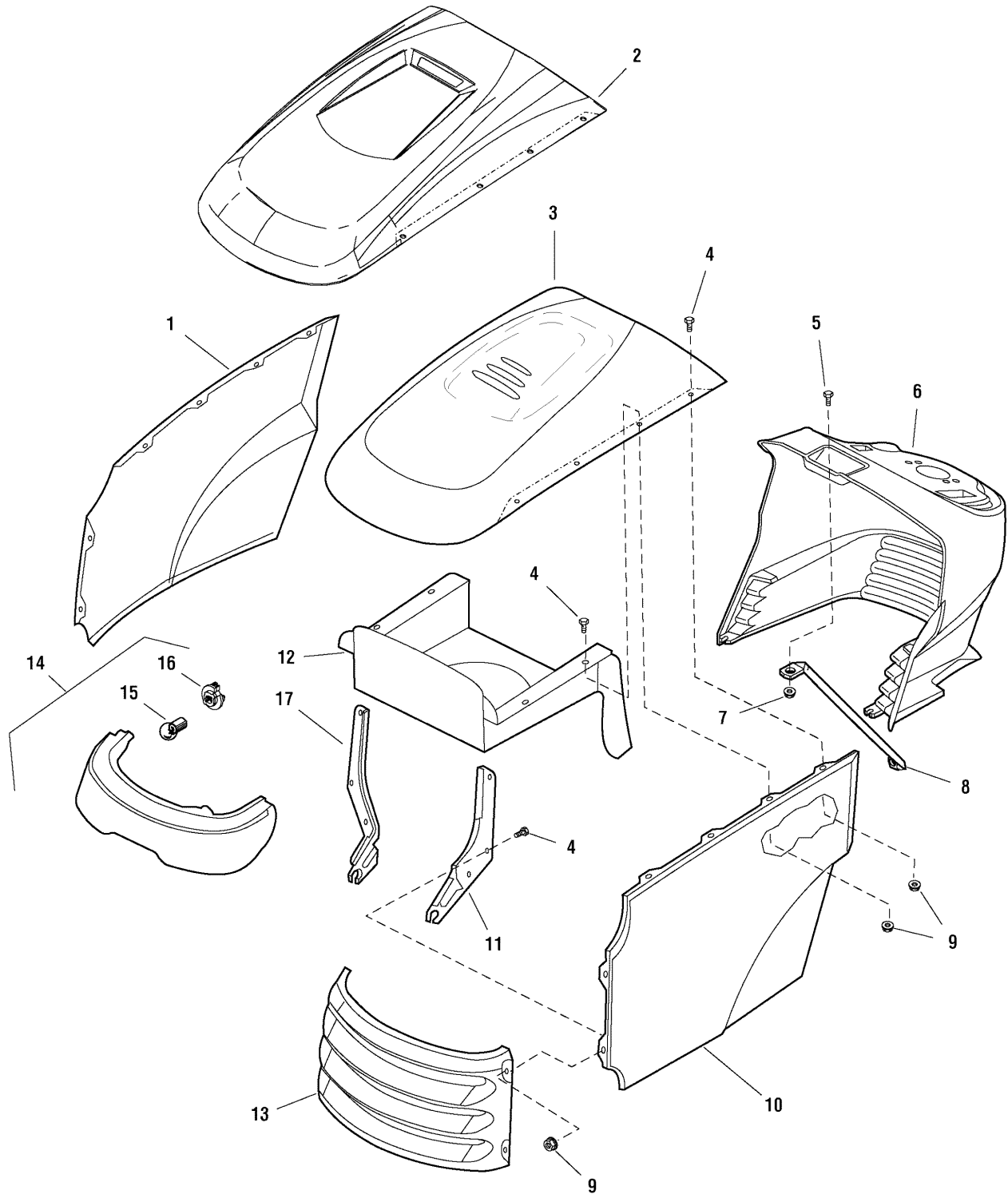

The above parts group applies to the following Mfg. Nos.:

1695415 - Conquest

2690679 - Conquest

2690744 - Conquest

Hood, Grille & Dash Group

REF NO	PART NO.	QTY.	DESCRIPTION
1	1721804CSM	1	PANEL, RH Side
1	1721804DSM	1	PANEL, RH Side, Red
2	1728031DSM	1	HOOD, with Scoop, Red
3	1722110CSM	1	HOOD, with Louvers
4	1960295SM	12	CAPSCREW, Hex Head Flange Lock, 1/4-20 x 5/8
5	1960392SM	1	SCREW, Phillips Head, #10-24 x 1/2
6	1687054SM	1	DASHBOARD, RMO, Black
6	1687055SM	1	DASHBOARD, RMO with Hydra Lift Slot, Black
7	1933896SM	1	NUT, Hex Nylock, #10-24
8	1723123SM	1	ROD, Dash Support
9	1930641SM	12	NUT, Hex Flange Lock, 1/4-20
10	1721803CSM	1	PANEL, LH Side
10	1721803DSM	1	PANEL, LH Side, Red
11	1721808ASM	1	HINGE, LH
12	1733457ASM	1	DUCT, Air Inlet
13	1721802CSM	1	GRILLE
13	1721802DSM	1	GRILLE, Red
14	1721810SM	1	HEADLIGHT ASSEMBLY (Includes Ref. Nos. 15 & 16)
15	1677371SM	4	BULB, Headligh
16	1723451SM	4	SOCKET, Headlight
17	1721809ASM	1	HINGE, RH

Footnotes

The above parts group applies to the following Mfg. Nos.:

1695415 - Conquest

2690679 - Conquest

2690744 - Conquest

Seat & Seat Deck Group

985909

NOTE: Unless noted otherwise,
use the standard hardware torque
specification chart.

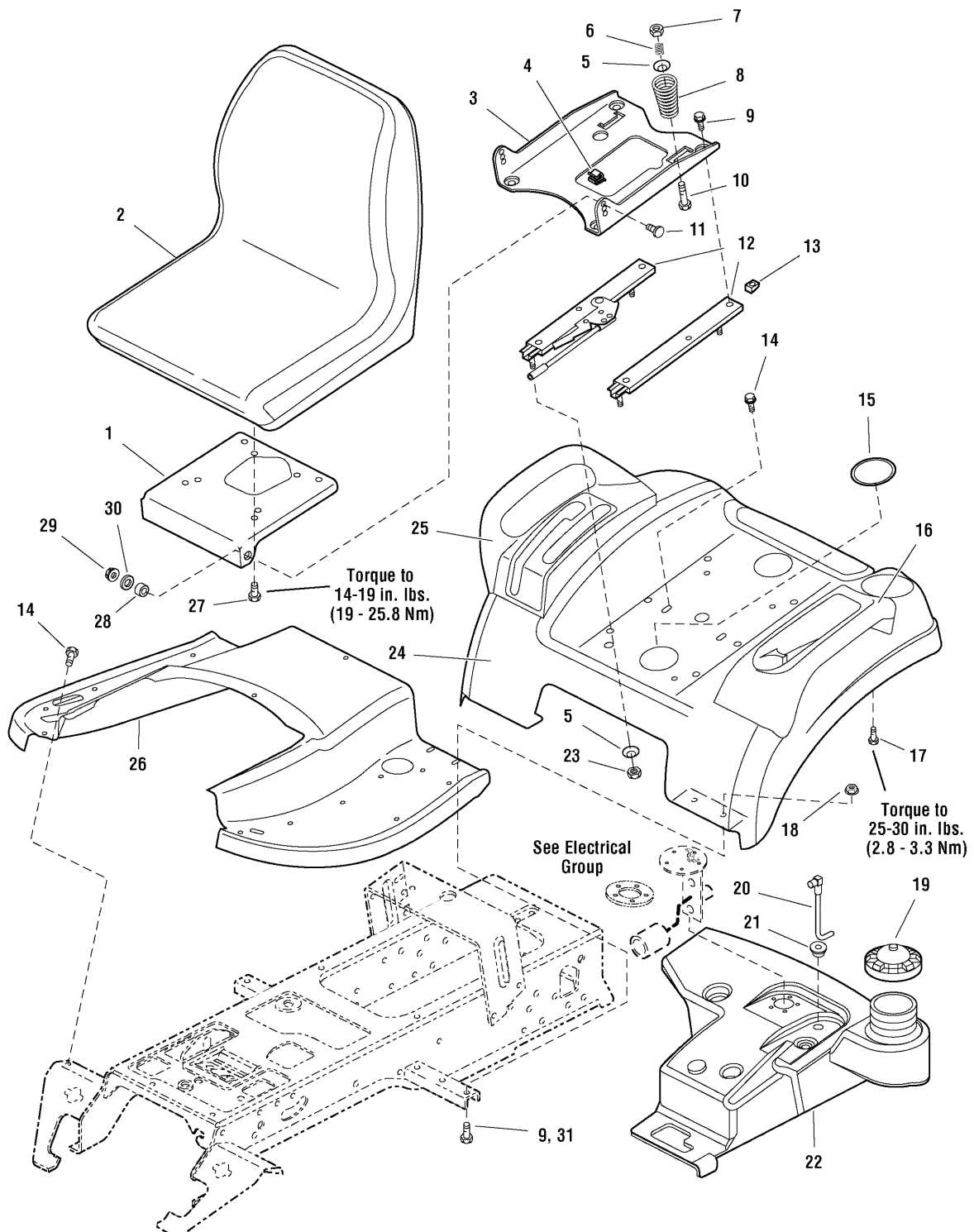

The above parts group applies to the following Mfg. Nos.:

1695415 - Conquest

2690679 - Conquest

2690744 - Conquest

Seat & Seat Deck Group

REF NO	PART NO.	QTY.	DESCRIPTION
1	1722129ASM	1	BRACKET, 1-5/8 x 1-3/4
2	1687199SM	1	SEAT, 18" Back
3	1722128ASM	1	SUPPORT, Seat
4	2172434SM	1	CLIP, Wire
5	1709256SM	2	WASHER, Spring, 5/16 x 1-1/4
6	1714263SM	2	SPRING, Compression
7	1919438SM	10	NUT, Hex Lock, ESNA Light, 5/16-18
8	1717051SM	2	SPRING, Compression
9	1930591SM	8	CAPSCREW, Hex Flange Whiz Lock, 5/16-18 x 3/4
10	1931339SM	2	CARRIAGE BOLT, 5/16-18 x 2
11	1931350SM	2	CARRIAGE BOLT, 3/8-16 x 1
12	1722356SM	1	SLIDE, Seat
13	1935255SM	4	NUT, Speed, 5/16-18, Lug Type
14	1930601SM	4	CAPSCREW, Hex Washer Head Taptite, 5/16-18 x 5/8
15	1722309SM	2	PLUG, Plastic
16	1729711SM	1	POD, with Cup Holder, LH
17	2860664SM	8	CAPSCREW, Hex Washer Head, 1/4-20 x 5/8
18	1931277SM	4	NUT, Hex Flange Whiz Lock, 5/16-18
19	1715917SM	1	CAP, Gas
20	1722340SM	1	TUBE & ELBOW ASSEMBLY
21	1654930SM	1	BUSHING, 3/8 x 9/16 x 5/8, Rubber
22	1722432SM	1	TANK, Fuel
23	1960636SM	8	NUT, Hex KEPS, 5/16-18
24	1722106CSM	1	DECK, Seat, Orange
24	1722106DSM	1	DECK, Seat, Red
25	1722108SM	1	POD, RH with 2 Slots
26	1722105CSM	1	TUNNEL, Orange
26	1722105DSM	1	TUNNEL, Red
27	1960667SM	4	SCREW, Hex Flange Whiz Lock, 5/16-18 x 1
28	1663752SM	2	SPACER, 25/64 x 5/8 x 3/16, Hardened
29	1930645SM	2	NUT, Hex Flange Two-Way Lock, 3/8-16
30	1924940SM	2	WASHER, 3/8
31	1930595SM	4	SCREW, Taptite 5/16-18 x 1-1/4

Footnotes

The above parts group applies to the following Mfg. Nos.:

1695415 - Conquest
2690679 - Conquest
2690744 - Conquest

Lift Group - Manual Lift

985894

NOTE: Unless noted otherwise,
use the standard hardware torque
specification chart.

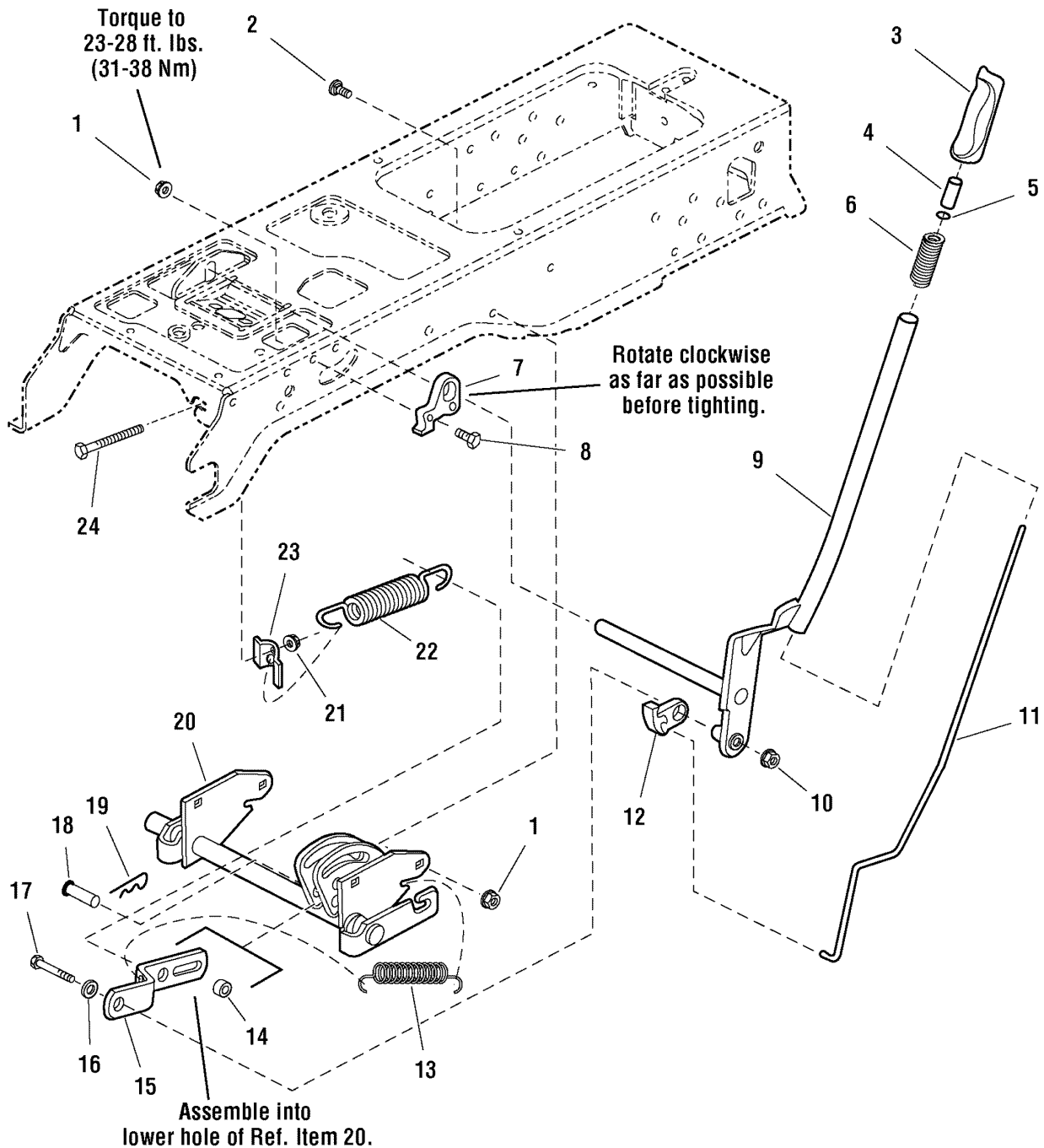

The above parts group applies to the following Mfg. Nos.:

1695415 - Conquest

2690679 - Conquest

2690744 - Conquest

Lift Group - Manual Lift

REF NO	PART NO.	QTY.	DESCRIPTION
1	1927557SM	2	NUT, Hex Whiz Lock Flange, 5/16-18, Large, Black
2	1931333SM	4	CARRIAGE BOLT, 5/16-18 x 3/4
3	1722291SM	1	GRIP, Lift Lever
4	1723124SM	1	BUTTON, Red Nylon, for 1/4 Rod
5	1960674SM	1	NUT, Push
6	1723321SM	1	SPRING, Compression, Lift Lever
7	1721581SM	1	QUADRANT, Lift, Powdered Metal
8	1926149SM	2	CAPSCREW, Hex Head, 5/16-18 x 1, G8, Black
9	1721712ASM	1	LEVER ASSEMBLY, Lift
10	1960636SM	5	NUT, Hex KEPS, 5/16-18
11	1722482SM	1	ROD, Latch
12	1722112SM	1	LOCK, Lift, Powdered Metal
13	2156302SM	1	SPRING, Extension
14	1723163SM	1	SPACER, 1/2 x 3/4 x 23/32
15	1723795ASM	1	BAR, Lift, 9-7/8 Long
16	1919381SM	1	WASHER, 5/16, Black
17	1921160SM	1	CAPSCREW, Hex Head, 5/16-18 x 2-1/4
18	1722819SM	1	PIN, Flat Head Drilled, 1/2 x 2-1/8 Long
19	1960033SM	1	CLIP, Hair Pin, 2-9/16 Long
20	1727436ASM	1	SHAFT ASSEMBLY, Lift
21	1935255SM	1	NUT, Speed, 5/16-18, Lug
22	1675232SM	1	SPRING, Compression
23	1723499SM	1	RETAINER, Spring Flat
24	1722357SM	1	CAPSCREW, Hex Washer Head, 5/16-18 x 4-1/2

Footnotes

The above parts group applies to the following Mfg. Nos.:

1695415 - Conquest
2690679 - Conquest
2690744 - Conquest

Wheels & Tires Group

NOTE: Unless noted otherwise,
use the standard hardware torque
specification chart.

W987669

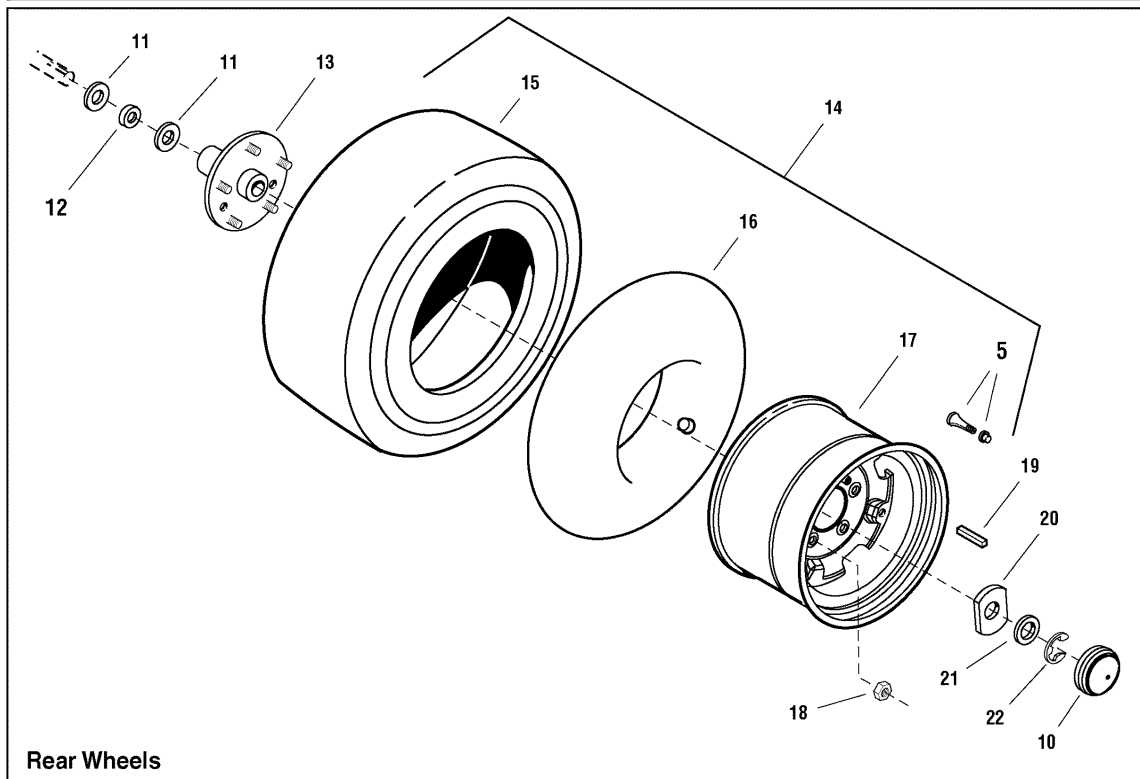
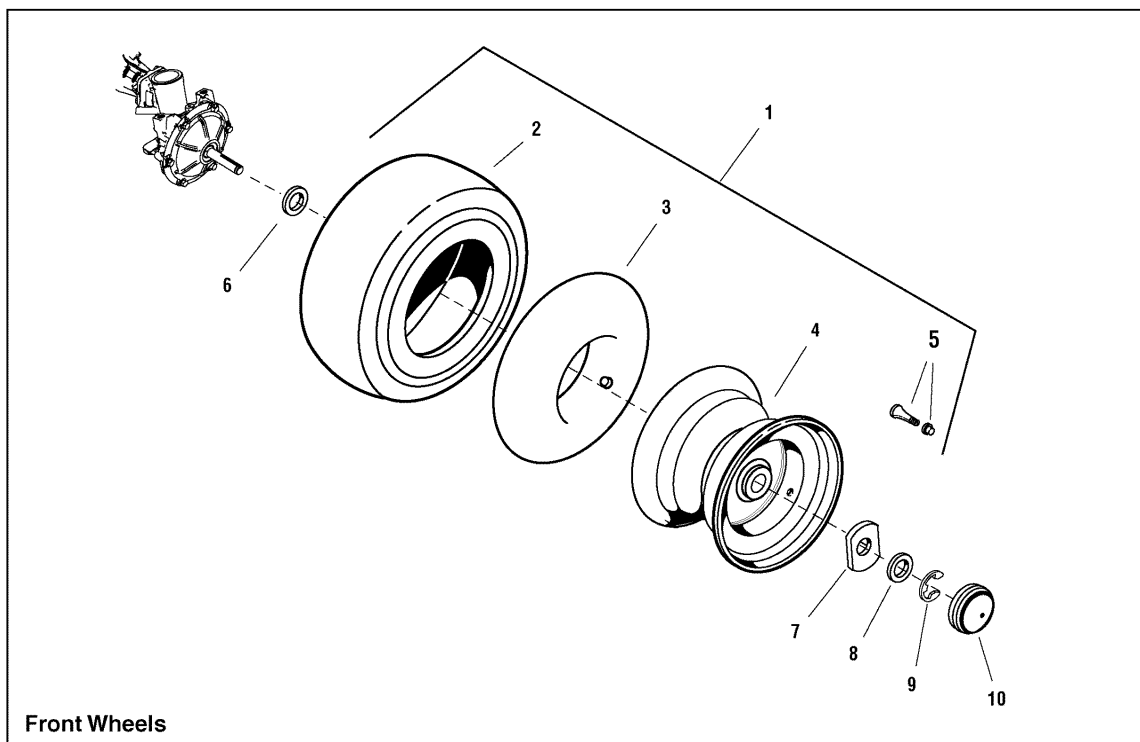

The above parts group applies to the following Mfg. Nos.:

1695415 - Conquest

2690679 - Conquest

2690744 - Conquest

Wheels & Tires Group

REF NO	PART NO.	QTY.	DESCRIPTION
1	1735010SM	2	WHEEL & TIRE ASSEMBLY (Includes Ref. Nos. 2, 3, 4 & 5)
2	1735706SM	2	TIRE, 16 x 6-1/2-8
3	2153038SM	2	TUBE, Tire
4	1733237SM	2	WHEEL ASSEMBLY
5	2172353SM	4	VALVE STEM & CAP
6	2860202SM	2	WASHER, Flat 3/4 x 1-5/8 x 1/8
7	1722717ASM	2	WASHER, Flat
8	1960114SM	2	WASHER, 3/4
9	2827794SM	2	RING
10	1722676SM	4	CAP, Hub
11	1960701SM	4	WASHER, 1 x 2-1/4 x 1/8
12	1726089SM	2	SPACER
13	1721400SM	2	PLATE & HUB WELDMENT
14	1735011SM	2	WHEEL & TIRE ASSEMBLY (Includes Ref. Nos. 5, 15, 16 & 17)
15	1735705SM	2	TIRE, 23 x 10-1/2-12
16	2157638SM	2	TUBE, Tire
17	1722831SM	2	WHEEL
18	2177725SM	10	NUT, Hex 7/16-20 For Wheel Bolt
19	2105337SM	2	KEY, Hi-Pro 1/4 x 2
20	1722726ASM	2	WASHER, Flat
21	1919394SM	2	WASHER, Flat
22	2834712SM	2	RING

Footnotes

The above parts group applies to the following Mfg. Nos.:

1695415 - Conquest

2690679 - Conquest

2690744 - Conquest

Decals Group

NOTE: Unless noted otherwise, use the standard hardware torque specification chart.

D987669

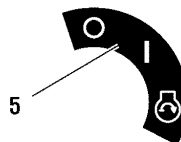
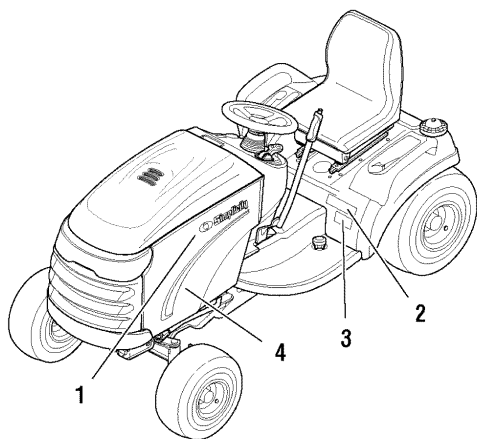

⚠ DANGER

Amputation hazard
 • Rotating blades cut off arms and legs.
 • Stop the mower when children or others are near.
 • Do not carry riders (especially children) even with the blades off. They may fall off or refuse to dismount rider when you are not dismounting it.
 • Look down and behind before and while backing.

Roll-over hazard
 • Operating on slopes can cause loss of control and roll-overs.
 • 4WD improves access to dangerously sloped terrain, increasing the possibility of roll-over.
 • Never operate on slopes greater than 10°.
 • If machine slips while going uphill, stop the blades and back down slowly.
 • Avoid sudden turns. Go up and down slopes just ahead.

Fire hazard
 • Gasoline is flammable. Yard debris is combustible.
 • Allow engine to cool for at least 3 minutes before refueling.
 • Keep out of cleaned of debris.

Carbon monoxide hazard
 • The engine emits poisonous carbon monoxide gas.
 • Avoid emitting exhaust fumes.
 • Only operate outdoors.

⚠ WARNING: Avoid serious injury or death
 • Know the location and function of all controls.
 • Keep safety devices (guards, shields, etc.) in place and working at all times.
 • Remove debris that could be thrown by the blades (playing yards or feet near blades).
 • Be sure blades and angles are stopped before refueling.
 • When leaving machine, shut off, remove key, and set parking brake.

Read the operator's manual before using this product.

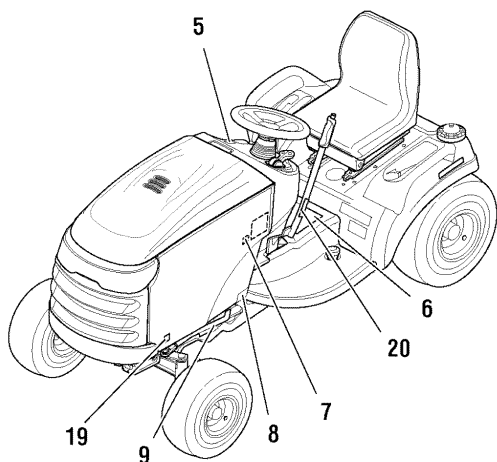

A grid of safety icons including: a warning triangle, an open book, a person being struck by a blade, a person being struck by a wheel, a person being struck by a moving part, a person being struck by a falling object, a person being struck by a rotating part, a person being struck by a sharp edge, a person being struck by a hot surface, a person being struck by a moving part, a person being struck by a falling object, a person being struck by a rotating part, a person being struck by a sharp edge, a person being struck by a hot surface.

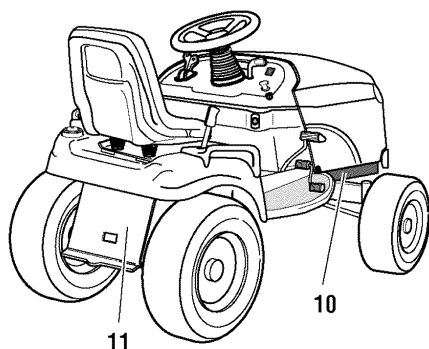

HI
 •
 •
 •
LO

⚠ DANGER
ROTATING CUTTING BLADE
 Do not operate mower without deflector or entire grass catcher in place.

⚠ DANGER
ROTATING CUTTING BLADE
 Do not put hands or feet under mower deck while blade is rotating.

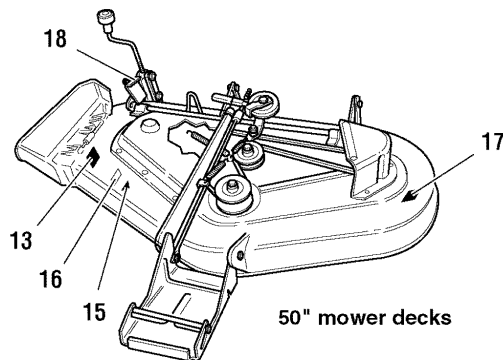

The above parts group applies to the following Mfg. Nos.:

- 1695415 - Conquest
- 2690679 - Conquest
- 2690744 - Conquest

Decals Group

REF NO	PART NO.	QTY.	DESCRIPTION
1	1722551SM	3	DECAL, Simplicity Silver & Blue w/Icon
2	1722820SM	1	DECAL, Conquest, Silver & Blue
3	1722781SM	1	DECAL, 23HP Silver on Clear
4	1722773SM	1	DECAL, Hood Stripe R.H. SMI Blue & Silver
4	1722774SM	1	DECAL, Hood Stripe L.H. SMI Blue & Silver
5	1722806SM	1	DECAL, Ignition Switch Symbols
6	1734026SM	1	DECAL, Tunnel Cover Danger Slopes, Blades
6	1734027SM	1	DECAL, Tunnel Cover Danger Slopes, Blades (CE/Export)
7	1734142SM	1	DECAL, Touch Up Paint
8	1723296SM	2	STICKER, Protection
9	*	1	DECAL, I.D. Plate
10	*	1	DECAL, Patent
11	1723160SM	1	DECAL, Transmission Release Valve
13	1704277SM	1	DECAL, Danger Do Not Operate w/o Deflector
13	1720389SM	1	DECAL, Danger Rotating Blade (CE/Export)
15	*	1	DECAL, OPEI Certified
16	1706640SM	1	DECAL, 50" Silver on Black w/Stripe
17	1704276SM	1	DECAL, Danger Do Not Put Hand/Feet In Mower
18	1721197SM	1	DECAL, 1 2 3 4 5 6, Height of Cut White/Black
19	1726373SM	2	DECAL, 4x4
20	1723143SM	1	DECAL, Lift (Used only on Domestic Models)

Footnotes

NOTE * Not a serviceable part.

The above parts group applies to the following Mfg. Nos.:

1695415 - Conquest
2690679 - Conquest
2690744 - Conquest

44" & 50" Mower Deck - Clutch & Support Group

987599

NOTE: Unless noted otherwise,
use the standard hardware torque
specification chart.

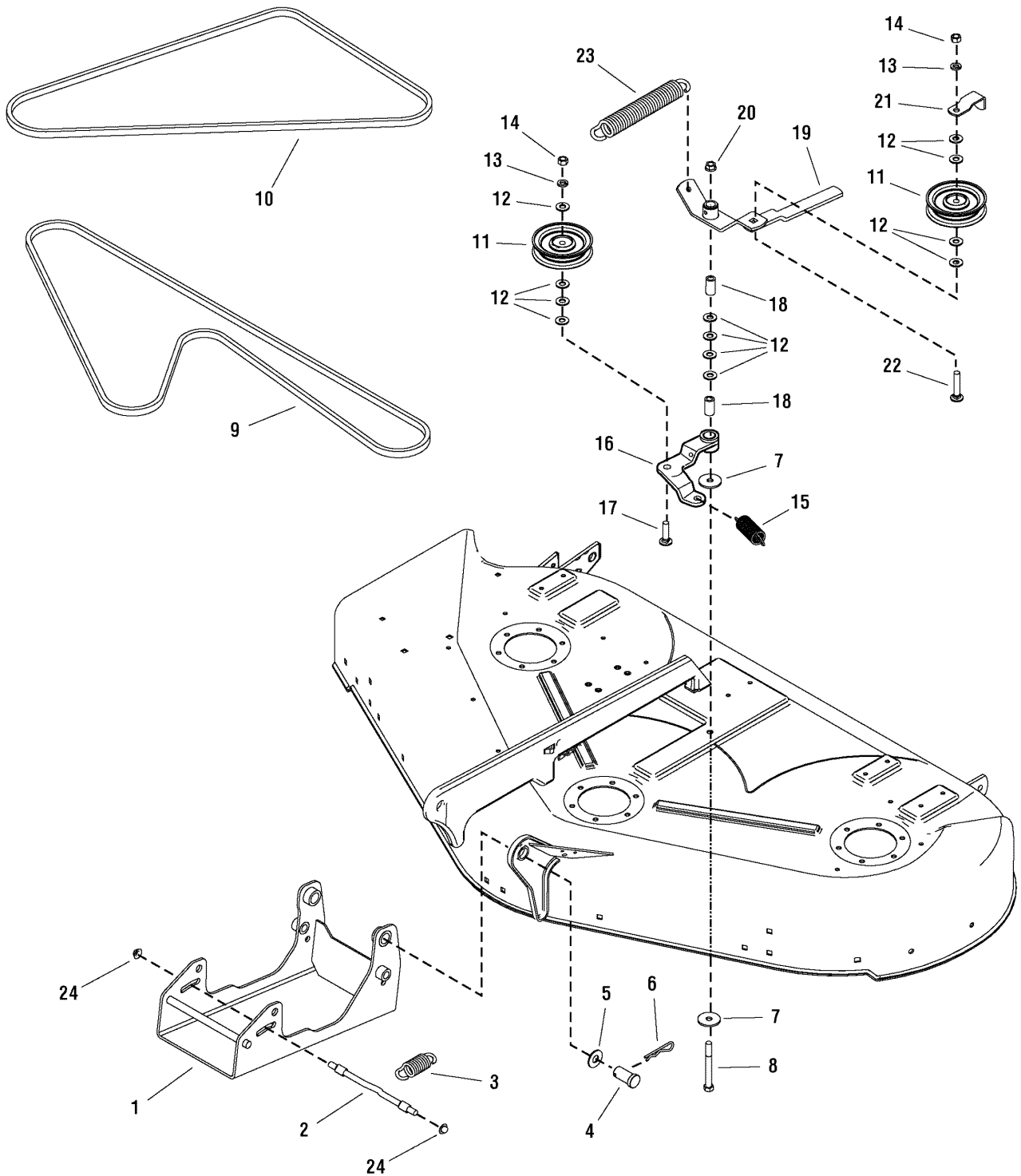

The above parts group applies to the following Mfg. Nos.:

1695395 - 50" Mower

2690679 - Conquest

2690744 - Conquest

44" & 50" Mower Deck - Clutch & Support Group

REF NO	PART NO.	QTY.	DESCRIPTION
1	1732977ASM	1	HITCH & RODS ASSEMBLY, 4WD
2	1715759SM	1	ROD
3	2156302SM	1	SPRING, Extension
4	1733830SM	2	PIN, Clevis
5	2860202SM	2	WASHER, 3/4
6	1960033SM	2	CLIP, Hair Pin
7	1924356SM	2	WASHER, 3/8
8	1923938SM	1	CAPSCREW, Hex Head 3/8-15 x 3-1/2 G5
9	1703836SM	1	V-BELT, Arbor Drive (Used only on 50" Mower)
9	1721532SM	1	V-BELT, Arbor Drive (Used only on 44" Mower)
10	1734114SM	1	V-BELT, Mower Drive 70.1 (Used only on 50" Mower)
10	1734115SM	1	V-BELT, Mower Drive 62.1 (Used only on 44" Mower)
11	1724387SM	2	PULLEY, Idler
12	1924940SM	12	WASHER, 3/8
13	1916965SM	2	LOCKWASHER, Spring 3/8
14	1916950SM	2	NUT, Hex 3/8-16
15	1656936SM	1	SPRING, Extension
16	1718561SM	1	LEVER ASSEMBLY, Idler w/Bushing & Fitting
17	1931352SM	1	CARRIAGE BOLT, 3/8-16 x 1-1/2 G5
18	1674669SM	2	SPACER
19	1704658SM	1	LEVER ASSEMBLY, Idler w/Bushings & Fitting
20	1960339SM	1	NUT, Hex Flange 3/8-16 Machine Lock
21	1677135ASM	1	GUARD, Belt
22	1960315SM	1	CARRIAGE BOLT, 3/8-16 x 2 G5
23	1715435SM	1	SPRING, Extension
24	1960093SM	2	NUT, Push Pal 3/8 Diameter Stud Capped

Footnotes

The above parts group applies to the following Mfg. Nos.:

1695395 - 50" Mower
2690679 - Conquest
2690744 - Conquest

50" Mower Deck - Height Adjustment & Roller Bar Group

987883

NOTE: Unless noted otherwise,
use the standard hardware torque
specification chart.

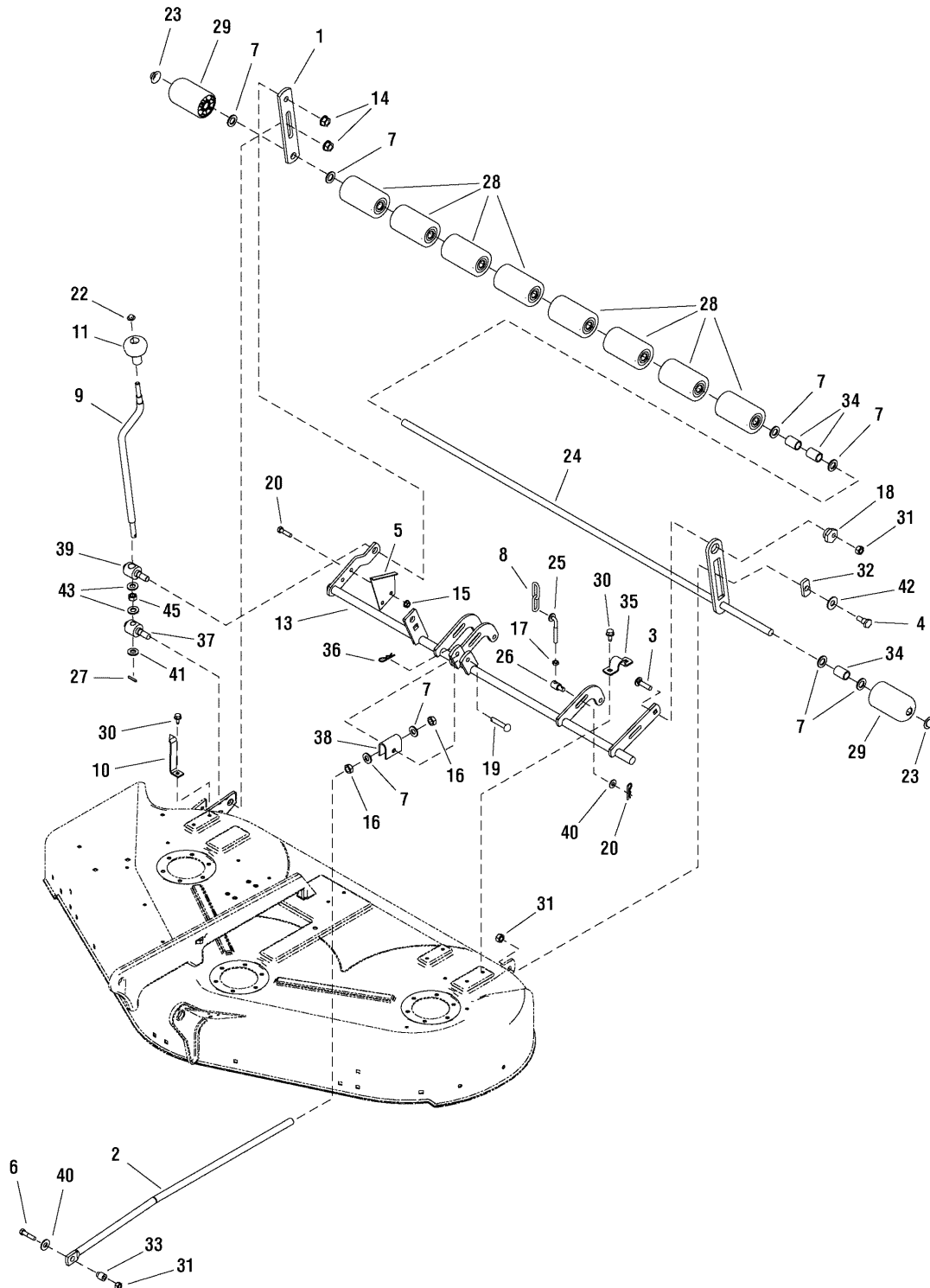

The above parts group applies to the following Mfg. Nos.:

1695395 - 50" Mower

2690744 - Conquest

50" Mower Deck - Height Adjustment & Roller Bar Group

REF NO	PART NO.	QTY.	DESCRIPTION
1	1704074ASM	1	BAR, Roller 5/16
2	1722995SM	1	ROD, Adjusting
3	1931352SM	1	CARRIAGE BOLT, 3/8-16 x 1-1/2 G5
4	2172622SM	1	BOLT, Shoulder, 3/8-16 G5
5	1704116ASM	1	BRACKET, Height of Cut 16GA
6	1922606SM	1	CAPSCREW, Hex Head 3/8-16 x 1-3/4 G8
7	1924366SM	8	WASHER, 5/8
8	1731383ASM	2	CHAIN, Link
9	1719901SM	1	CRANK, Height Adjusting
10	1720643ASM	1	INDICATOR, Height
11	1714084SM	1	KNOB, Spinner
13	1733522ASM	1	SHAFT ASSEMBLY, Rocker 50"
14	1930644SM	2	NUT, Hex Flange 1/2-13 Two-Way Lock
15	1931277SM	2	NUT, Hex Flange 5/16-18 Whiz Lock Small
16	1915726SM	2	NUT, Hex 5/8-11
17	1920161SM	2	NUT, Hex Jam 5/16-18
18	1704082SM	1	NUT, Hex Adjusting
19	2118053SM	1	PIN, Round Head Drilled 3/8 x 2
20	1930591SM	2	SCREW, Hex Whiz Lock Flange 5/16-18 x 3/4
22	1960093SM	1	NUT, Push Pal 3/8 Diameter Stud Capped
23	1960520SM	2	NUT, Push for 5/8 Diameter Stud Capped
24	1716155ASM	1	SHAFT & BAR ASSEMBLY, Roller
25	1731384SM	2	ROD, Height Adjust (Long)
25	1724959SM	2	ROD, Height Adjust (Short)
26	1731382SM	2	TRUNNION
27	2816001SM	1	PIN, Spring
28	1668513SM	8	ROLLER
29	1722036SM	2	ROLLER, Rounded
30	1664847SM	6	SCREW, Hex Washer Head Taptite 5/16-18 x 3/4
31	2860681SM	3	NUT, Hex Toplock Spiral lock Flange 3/8-16
32	1677507SM	1	SLIDE
33	1706644SM	1	SPACER, 3/8 x 3/4 x 15/16
34	1709195SM	3	SPACER
35	1665374SM	3	STRAP, Roller
36	1960074SM	3	CLIP, Hair Pin
37	1733257SM	1	TRUNNION
38	1706645ASM	1	TRUNNION
39	1733258SM	1	TRUNNION
40	1924940SM	3	WASHER, 3/8
41	1704097SM	1	WASHER, Detent
42	1924361SM	1	WASHER, 1/2
43	1960170SM	1	WASHER, 1/2
45	1716953SM	1	SPACER

Footnotes

The above parts group applies to the following Mfg. Nos.:

1695395 - 50" Mower
2690744 - Conquest

50" Mower Deck - Height Adjustment & Roller Bar Group

987642

NOTE: Unless noted otherwise,
use the standard hardware torque
specification chart.

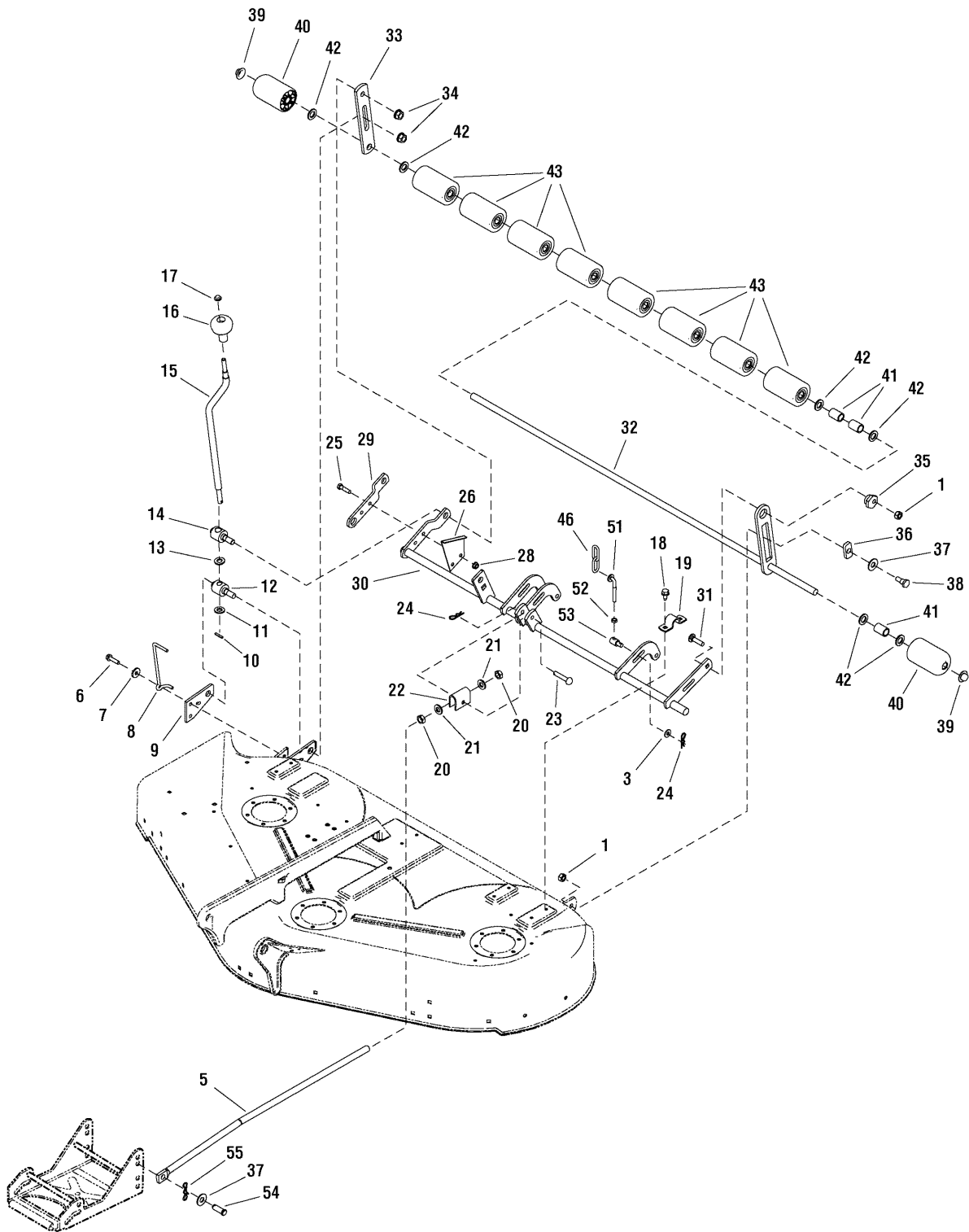

The above parts group applies to the following Mfg. Nos.:
2690679 - Conquest

50" Mower Deck - Height Adjustment & Roller Bar Group

REF NO	PART NO.	QTY.	DESCRIPTION
1	2860681SM	2	NUT, Hex Toplock Spirallock Flange 3/8-16
3	1924940SM	2	WASHER, 3/8
5	1722995SM	1	ROD, Adjusting
6	1931202SM	2	SCREW, Hex Washer Head Taptite 5/16-18 x 1-1/4
7	1919381SM	1	WASHER, 5/16
8	1704114SM	1	INDICATOR, Cutting Height
9	1704080ASM	1	PLATE, Mower Support
10	2816001SM	1	PIN, Spring
11	1704097SM	1	WASHER, Detent
12	1704086SM	1	TRUNNION, 1-1/4
13	1960170SM	1	WASHER, 1/2
14	1704087SM	1	TRUNNION, 1-1/4
15	1719901SM	1	CRANK, Height Adjusting
16	1714084SM	1	KNOB, Spinner
17	1960093SM	1	NUT, Push Pal 3/8 Diameter Stud Capped
18	1664847SM	6	SCREW, Hex Washer Head Taptite 5/16-18 x 3/4
19	1665374SM	3	STRAP
20	1915726SM	2	NUT, Hex 5/8-11
21	1924366SM	2	WASHER, 5/8
22	1706645ASM	1	TRUNNION
23	2118053SM	1	PIN, Round Head Drilled 3/8 x 2
24	1960074SM	3	CLIP, Hair Pin
25	1921977SM	2	CAPSCREW, Hex Head 5/16-18 x 1-1/4 G5
26	1704116ASM	1	BRACKET, Height of Cut 16GA
28	1931277SM	2	NUT, Hex Flange 5/16-18, Whiz Lock Small
29	1704083ASM	1	ARM, Rear R.H.
30	1733522ASM	1	SHAFT ASSEMBLY, Rocker 50"
31	1931352SM	1	CARRIAGE BOLT, 3/8-16 x 1-1/2 G5
32	1716155ASM	1	SHAFT & BAR ASSEMBLY, Roller 50"
33	1704074ASM	1	BAR, Roller
34	1930644SM	2	NUT, Hex Flange 1/2-13 Two-Way Lock
35	1704082SM	1	NUT, Hex Adjusting
36	1677507SM	1	SLIDE
37	1924361SM	2	WASHER, 1/2
38	2172622SM	1	BOLT, Shoulder, 3/8-16 G5
39	1960520SM	2	NUT, Push for 5/8 Diameter Stud Capped
40	1722036SM	2	ROLLER, Rounded
41	1709195SM	3	SPACER
42	1924366SM	6	WASHER, 5/8
43	1668513SM	8	ROLLER
46	1731383ASM	2	CHAIN, Link
51	1731384SM	2	ROD, Height Adjusting
52	1920161SM	2	NUT, Hex Jam 5/16-18
53	1731382SM	2	TRUNNION

Footnotes

The above parts group applies to the following Mfg. Nos.:

2690679 - Conquest

50" Mower Deck - Height Adjustment & Roller Bar Group

987642

NOTE: Unless noted otherwise,
use the standard hardware torque
specification chart.

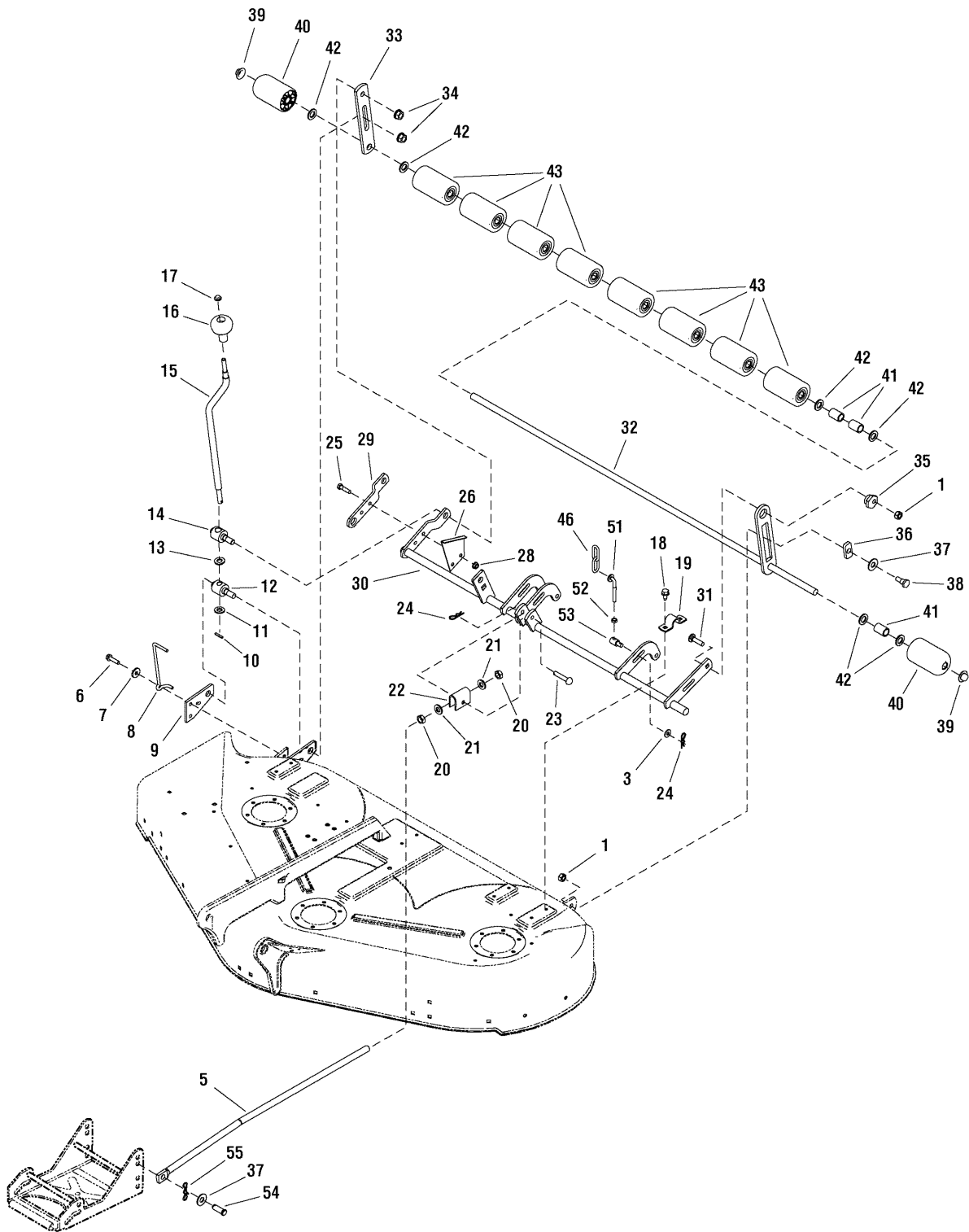

The above parts group applies to the following Mfg. Nos.:
2690679 - Conquest

50" Mower Deck - Height Adjustment & Roller Bar Group

REF NO	PART NO.	QTY.	DESCRIPTION
54	1960116SM	1	PIN, Yoke
55	1722320SM	1	PIN, Cotter Locking

Footnotes

The above parts group applies to the following Mfg. Nos.:

2690679 - Conquest

50" Mower Deck - Housing, Arbors & Blades Group

987519

NOTE: Unless noted otherwise, use the standard hardware torque specification chart.

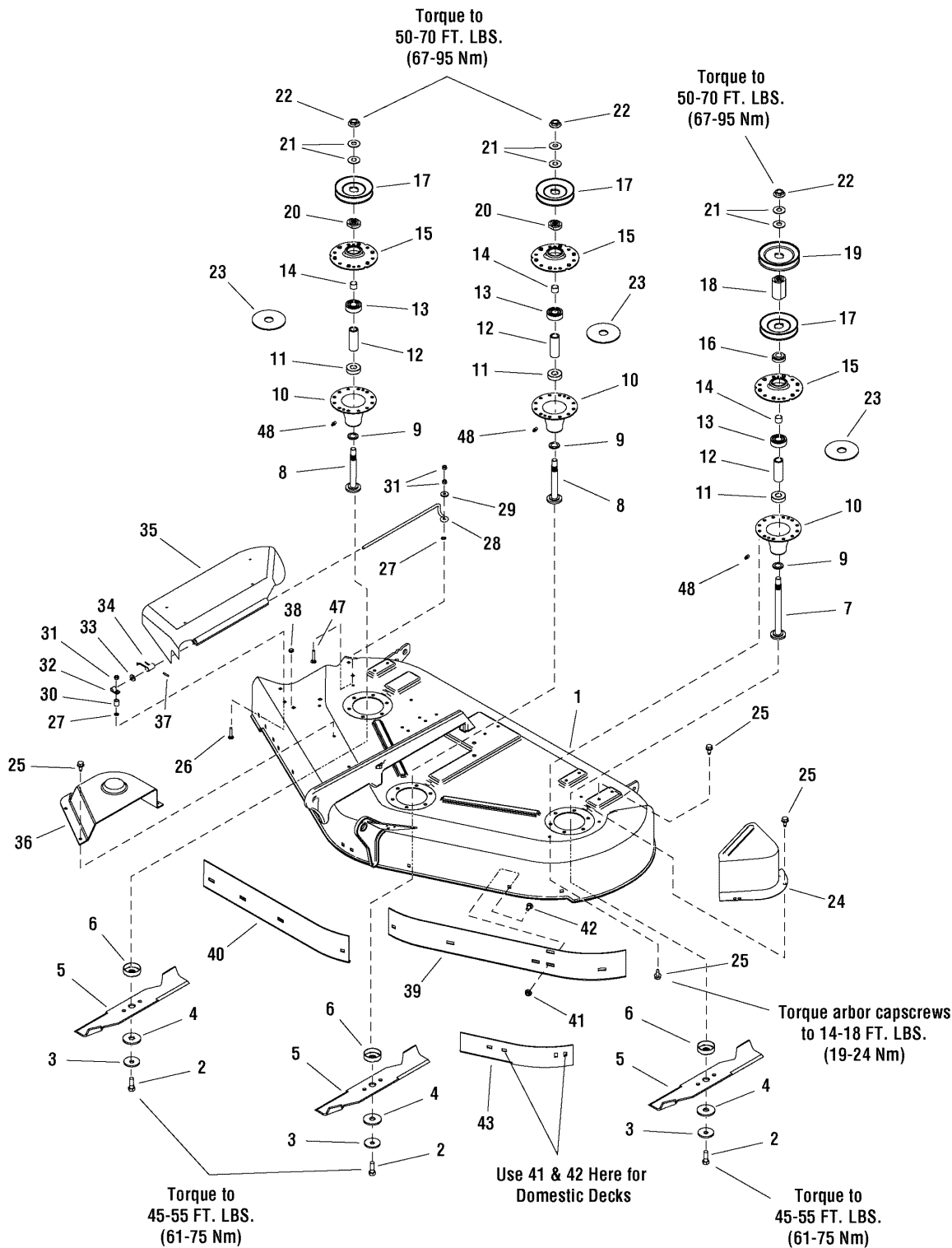

The above parts group applies to the following Mfg. Nos.:

- 1695395 - 50" Mower
- 2690744 - Conquest

50" Mower Deck - Housing, Arbors & Blades Group

REF NO	PART NO.	QTY.	DESCRIPTION
1	1687325SM	1	HOUSING ASSEMBLY, 50" (Orange)
1	1687326SM	1	HOUSING ASSEMBLY, 50" (Red)
2	2823471SM	3	CAPSCREW, Hex Head 7/16-14 x 1-1/4 G8
3	1656916SM	3	WASHER, Spring
4	1713089SM	3	WASHER, Hex, 11/16 x 2
5	1708229ASM	3	BLADE, Mower 50"
6	1713196SM	3	SHIELD, Grass Lower Arbor Heat Treat
7	1713612SM	1	SHAFT, Arbor
8	1713195SM	2	SHAFT, Arbor
9	1713619SM	3	WASHER, Cup
10	1713338ASM	3	HOUSING, Arbor Bottom w/Lube Fitting (Includes Ref. No. 48)
11	1705897SM	3	BEARING, Ball, 11/16 x 1-9/16 x 15/32
12	1732544SM	3	SPACER, Powdered Metal
13	2108202SM	3	BEARING, Ball
14	1715724SM	3	SPACER, 21/32 x 3/4 x 5/8
15	1655729ASM	3	HOUSING, Arbor Top
16	1713533SM	1	HUB, Powdered Metal
17	1713098SM	3	PULLEY
18	1713158SM	1	HUB, Serated Powdered Metal
19	1732951SM	1	PULLEY
20	1713197SM	2	HUB, Pulley, Center & R.H.
21	1713675SM	6	WASHER, Bellville
22	1714419SM	3	NUT, Hex Flange 9/16-18
23	1707335SM	3	GASKET, Foam Poly
24	1720560ASM	1	COVER, Arbor
25	1664847SM	27	SCREW, Hex Washer Head Taptite 5/16-18 x 3/4
26	1931320SM	2	CARRIAGE BOLT, 1/4-20 x 1-1/4 G5
27	1960518SM	2	NUT, Push for 1/4 Diameter Thread
28	1706709SM	1	ROD, Deflector E-Coat
29	1960353SM	1	WASHER
30	1710703SM	2	SPACER, Powdered Metal
31	1920397SM	2	NUT, Hex Lock ESNA Light 1/4-20
32	1704873SM	1	CLAMP, Wire
33	1919326SM	1	WASHER, 5/16
34	7101082SM	1	SPRING, Torsion Chute
35	1705449SM	1	DEFLECTOR
36	1715673SM	1	COVER, Arbor
37	1723323SM	1	CAP
38	1705115SM	1	PLUG, Button
39	1716870ASM	1	BAFFLE, Blowout 50" L.H. (CE/Export)
40	1735184ASM	1	BAFFLE, Blowout 50" R.H. (CE/Export)
41	1927557SM	2/11	NUT, Hex Flange 5/16-18 Whiz Lock Large
42	1921333SM	2/11	CAPSCREW, Hex Head 5/16-18 x 1 G5
43	1724538ASM	1	BAFFLE, Blowout (Domestic)

Footnotes

The above parts group applies to the following Mfg. Nos.:

1695395 - 50" Mower
2690744 - Conquest

50" Mower Deck - Housing, Arbors & Blades Group

987519

NOTE: Unless noted otherwise, use the standard hardware torque specification chart.

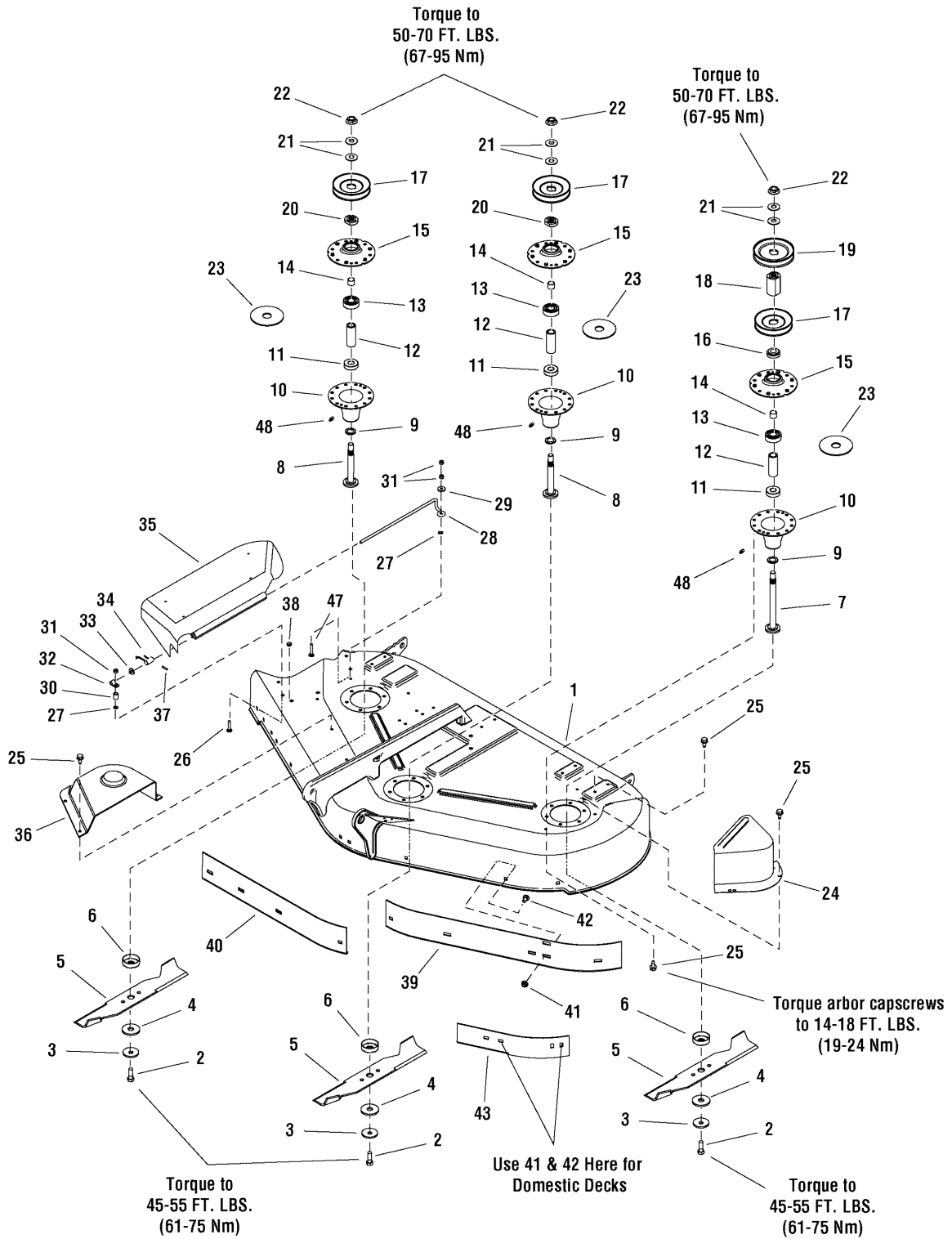

The above parts group applies to the following Mfg. Nos.:

- 1695395 - 50" Mower
- 2690744 - Conquest

50" Mower Deck - Housing, Arbors & Blades Group

REF NO	PART NO.	QTY.	DESCRIPTION
47	1960633SM	2	CARRIAGE BOLT, 1/4-20 x 1-1/2 G5
48	1704314SM	3	FITTING, Grease, 1/4 Drive

Footnotes

The above parts group applies to the following Mfg. Nos.:

1695395 - 50" Mower
2690744 - Conquest

50" Mower Deck - Housing, Arbors & Blades Group

985972

NOTE: Unless noted otherwise, use the standard hardware torque specification chart.

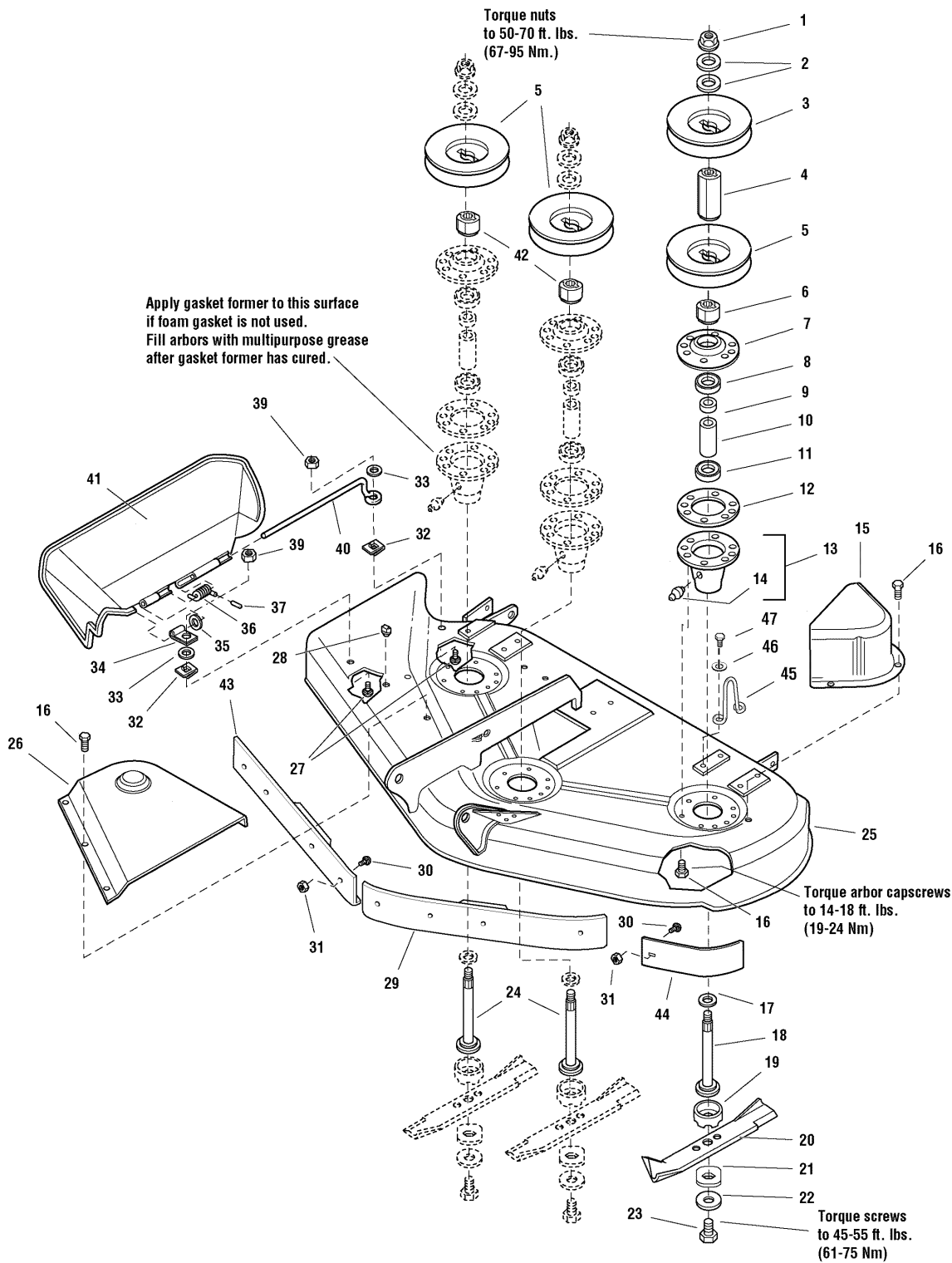

The above parts group applies to the following Mfg. Nos.:
2690679 - Conquest

50" Mower Deck - Housing, Arbors & Blades Group

REF NO	PART NO.	QTY.	DESCRIPTION
1	1714419SM	3	NUT, Hex Flange, 9/16-18
2	1713675SM	6	WASHER, Bellevilled, 9/16
3	1713161SM	1	PULLEY
4	1713158SM	1	HUB, Double Pulley
5	1713098SM	3	PULLEY
6	1713533SM	1	HUB, Double Pulley
7	1655729ASM	3	COVER, Arbor Housing
8	2108202SM	3	BEARING, Ball, 3/4 x 1-3/4 x 5/8
9	1715724SM	3	SPACER, 21/32 x 3/4 x 5/8
10	1732544SM	3	SPACER, 11/16 x 5/32 x 2-11/16
11	1705897SM	3	BEARING, Ball, 11/16 x 1-9/16 x 15/32
12	1707335SM	3	GASKET, Foam
13	1713338ASM	3	HOUSING ASSEMBLY, Arbor Bottom, w/Lube Fitting (Includes Ref. No. 14)
14	1704314SM	3	FITTING, Grease
15	1720560ASM	1	COVER, Arbor
16	1664847SM	26	CAPSCREW, Hex Head Taptite, 5/16-18 x 3/4
17	1713619SM	3	WASHER, Bellevilled, 9/16, Black
18	1713612SM	1	SHAFT, Arbor (LH)
19	1713196SM	3	SHIELD, Grass, Lower
20	1708229ASM	3	BLADE, Mower, 18-1/8
21	1713089SM	3	WASHER, Hex, 11/16 x 2
22	1656916SM	3	WASHER, Spring 15/32, Black
23	2823471SM	3	CAPSCREW, Hex Head, 7/16-14 x 1
24	1713195SM	2	SHAFT, Arbor (Center & RH)
25	1685495SM	1	MOWER HOUSING ASSEMBLY, 50" Mower (Orange)
25	1687155SM	1	MOWER HOUSING ASSEMBLY, 50" Mower (Red)
26	1715673SM	1	COVER, Arbor
27	1931318SM	2	CARRIAGE BOLT, 1/4-20 x 7/8
28	1705115SM	1	PLUG, Hole
29	1716870ASM	1	BAFFLE, Anti-Blowout, LH (CE/Export)
30	1931333SM	2/11	CARRIAGE BOLT, 5/16-18 x 3/4
31	1927557SM	2/11	NUT, Hex, Whizlock, 5/16-18
32	1960518SM	2	NUT, Push
33	1960353SM	2	WASHER, 1/4, Black
34	1704873SM	1	CLAMP
35	1919326SM	1	WASHER, 5/16, Black
36	7101082SM	1	SPRING
37	1723323SM	1	CAP, Spring End
39	1920397SM	2	NUT, Hex, 1/4-20 ESNA
40	1706709SM	1	ROD, Deflector, Front
41	1705449SM	1	DEFLECTOR, Plastic
42	1713197SM	2	HUB, Pulley, Center & RH
43	1716869ASM	1	BAFFLE, Anti-Blowout, RH (CE/Export)
45	1719929SM	1	UPSTOP
44	1724538ASM	1	BAFFLE, Anit-Blowout

Footnotes

The above parts group applies to the following Mfg. Nos.:

2690679 - Conquest

Hardware Identification & Torque Specifications

Common Hardware Types

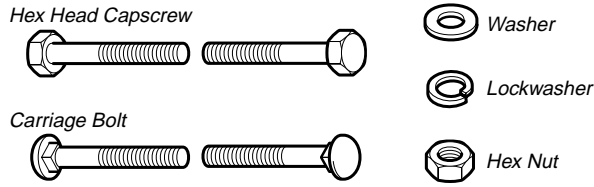

Standard Hardware Sizing

When a washer or nut is identified as 1/2", this is the *Nominal size*, meaning the *inside diameter* is 1/2 inch; if a second number is present it represents the *threads per inch*

When bolt or capscrew is identified as 1/2 - 16 x 2", this means the *Nominal size*, or *body diameter* is 1/2 inch; the second number represents the *threads per inch* (16 in this example, and the final number is the *body length* of the bolt or screw (in this example 2 inches long).

The guides and ruler furnished below are designed to help you select the appropriate hardware and tools.

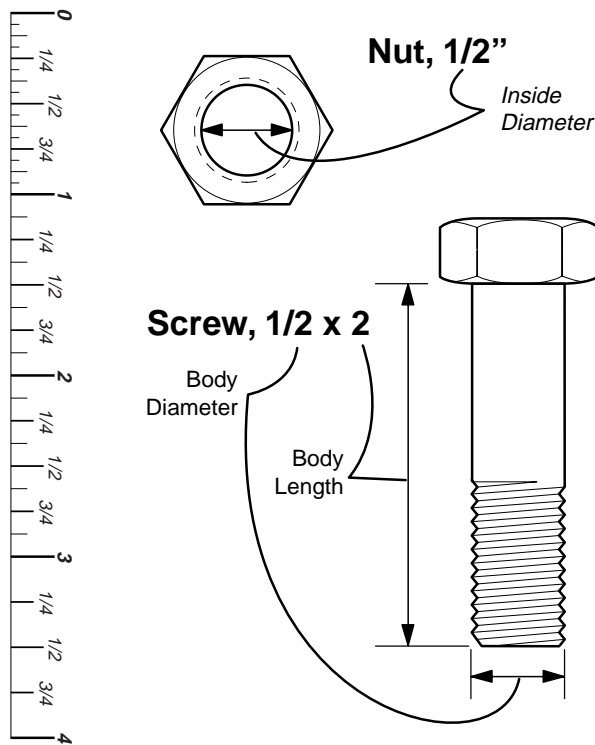

Torque Specification Chart

FOR STANDARD MACHINE HARDWARE (Tolerance ± 20%)

Hardware Grade	No Marks SAE Grade 2		SAE Grade 5		SAE Grade 8	
	in/lbs ft/lbs	Nm.	in/lbs ft/lbs	Nm.	in/lbs ft/lbs	Nm.
8-32	19	2.1	30	3.4	41	4.6
8-36	20	2.3	31	3.5	43	4.9
10-24	27	3.1	43	4.9	60	6.8
10-32	31	3.5	49	5.5	68	7.7
1/4-20	66	7.6	8	10.9	12	16.3
1/4-28	76	8.6	10	13.6	14	19.0
5/16-18	11	15.0	17	23.1	25	34.0
5/16-24	12	16.3	19	25.8	27	34.0
3/8-16	20	27.2	30	40.8	45	61.2
3/8-24	23	31.3	35	47.6	50	68.0
7/16-14	30	40.8	50	68.0	70	95.2
7/16-20	35	47.6	55	74.8	80	108.8
1/2-13	50	68.0	75	102.0	110	149.6
1/2-20	55	74.8	90	122.4	120	163.2
9/16-12	65	88.4	110	149.6	150	204.0
9/16-18	75	102.0	120	163.2	170	231.2
5/8-11	90	122.4	150	204.0	220	299.2
5/8-18	100	136	180	244.8	240	326.4
3/4-10	160	217.6	260	353.6	386	525.0
3/4-16	180	244.8	300	408.0	420	571.2
7/8-9	140	190.4	400	544.0	600	816.0
7/8-14	155	210.8	440	598.4	660	897.6
1-8	220	299.2	580	788.8	900	1,244.0
1-12	240	326.4	640	870.4	1,000	1,360.0

NOTES

- These torque values are to be used for all hardware excluding: locknuts, self-tapping screws, thread forming screws, sheet metal screws and socket head setscrews.
- Recommended seating torque values for locknuts:
 - for prevailing torque locknuts - use 65% of grade 5 torques.
 - for flange whizlock nuts and screws - use 135% of grade 5 torques.
- Unless otherwise noted on assembly drawings, all torque values must meet this specification.

Wrench & Fastener Size Guide



1/4" Bolt or Nut
Wrench—7/16"

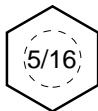

5/16" Bolt or Nut
Wrench—1/2"

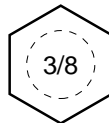

3/8" Bolt or Nut
Wrench—9/16"

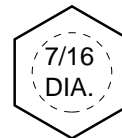

7/16" Bolt or Nut
Wrench (Bolt)—5/8"
Wrench (Nut)—11/16"

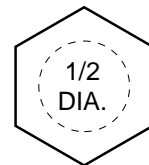

1/2" Bolt or Nut
Wrench—3/4"

Simplicity

MANUFACTURING, INC.
500 N. Spring Street / PO Box 997
Port Washington, WI 53074-0997 USA

www.simplicitymfg.com

Briggs and Stratton Yard Power Products Group
Copyright © 2007 by Briggs and Stratton Corporation
Milwaukee, WI, USA. All rights reserved

