

# Simplicity

## POWER TAKE-OFF Kit

### Mfr's. No. 461

For operation of Rotary Mower and Sickle Bar attachments, a Power take-off attachment is required. This consists of the Power Take-Off Assembly, "V" Pulley for Bevel Gear Shaft, Drive Belt, Belt Guard, and Belt stop packaged in one carton.

For ease of attachment follow the steps outlined below:

1. Mount Drive Pulley to Shaft of Bevel Gear Assembly See Figure 1, and secure in place with Key and Set Screw. Hub of Drive Pulley is to face inward. Place Drive Belt on Drive Pulley and mount Belt Guard Support to inside surface of Side Plate nearest Drive Pulley. See Figure 5 for Mounting Bolt location. Attach the Belt Guard to the Guard Support as shown in Figure 1. Allow approximately 3/16" clearance between Belt and Guard.

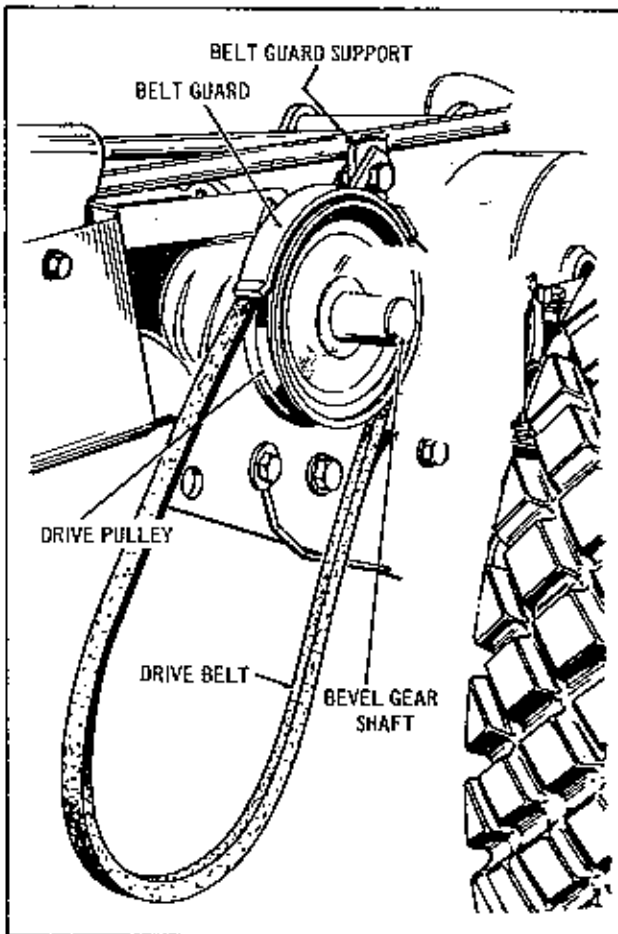

Figure 1

17345678910

2. Holding the Power Take-Off Assembly in left hand as shown in Figure 2, position the tube of the Drive Bracket Assembly between the Bevel Gear Housing Side Plates. Align the holes in Side Plates with the holes in Drive Bracket Assembly Tube and insert Pivot Pin through holes in Side Plates and Drive Bracket Assembly Tube.

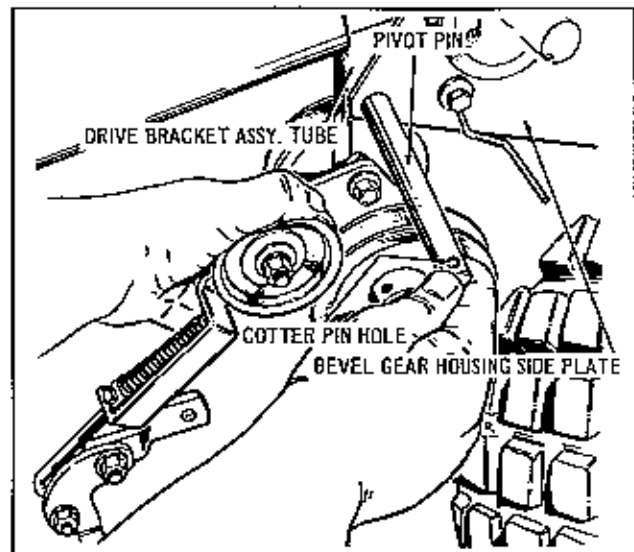

Figure 2

3. Push Pivot Pin through the holes in Bracket and Tube until the position of Cotter Pin Hole in Pivot Pin is as shown in Figure 3. Secure in position with Cotter Pin furnished.

4. Remove Hex. Cap Screw "D" from frame of tractor and mount bracket in place on Lift Lever Quadrant. See Figure 4. Position the Pivot Bar Assembly flush against bottom of Lift Quadrant and re-install Hex. Cap Screw and tighten securely. Check alignment of Drive Pulley on Bevel Gear Shaft, driven pulley of Power Take-Off, and Idler Pulley, and adjust Driving Pulley if necessary.

5. Remove Front Hex. Cap Screw from Pull Bar. Replace with stud 157273 provided. Short end inserted. Slip on Handle Assembly and tighten with Hex. HeadLock Nut to permit free movement of handle. Mount "V" Belt in place on driven pulley as shown in Figure 5 and attach spring to hole provided in the bottom of the Bracket Assembly. Hook

SIMPLICITY MANUFACTURING COMPANY, INC.

1294

PRINTED IN U. S. A.

other end of the spring to the Handle Assembly. Mount Belt Stop as shown with 3/8" Bolt, Flat Washer, Lock-washer, and Hex. Nut, When Implement is attached to tractor with Idler Pulley engaged, 1/8" clearance between Belt Stop and back of "V" Belt is required. NOTE: "V" Belt runs under Idler Pulley. See Figure 5.

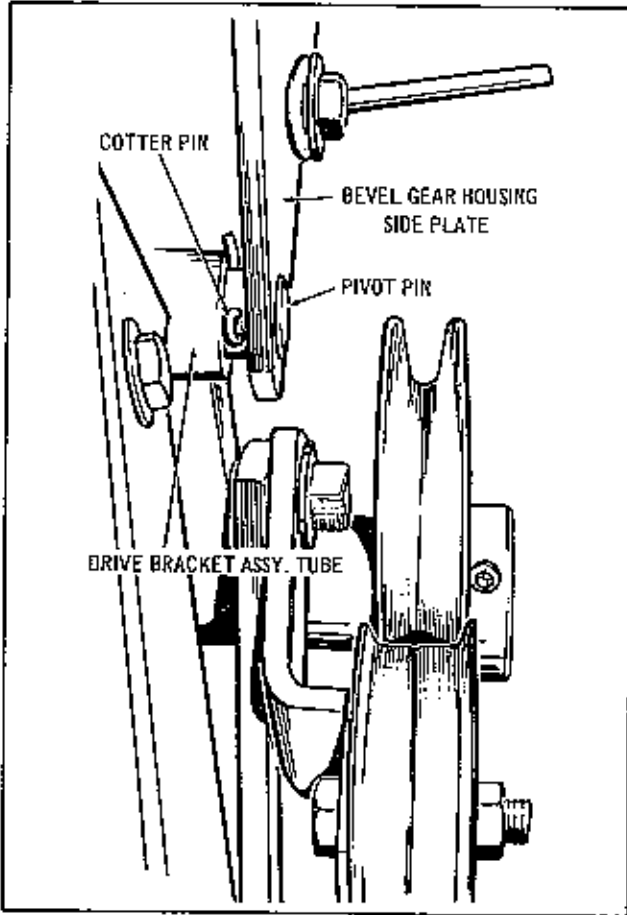

Figure 3

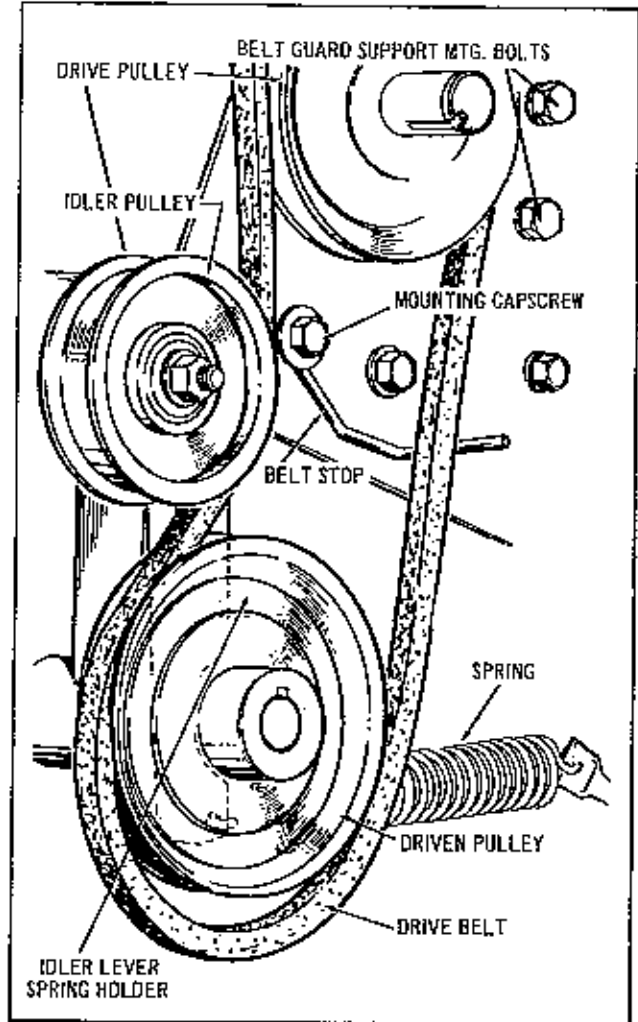

Figure 5

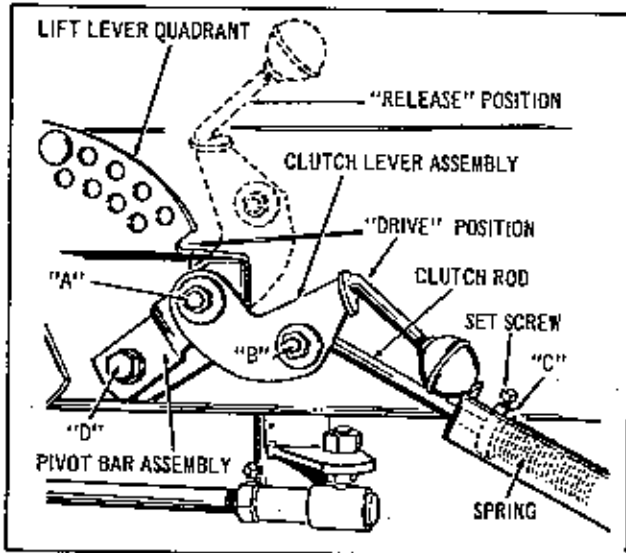

Figure 4

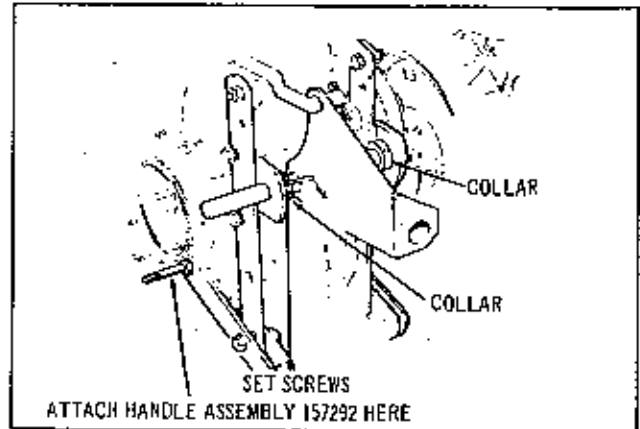
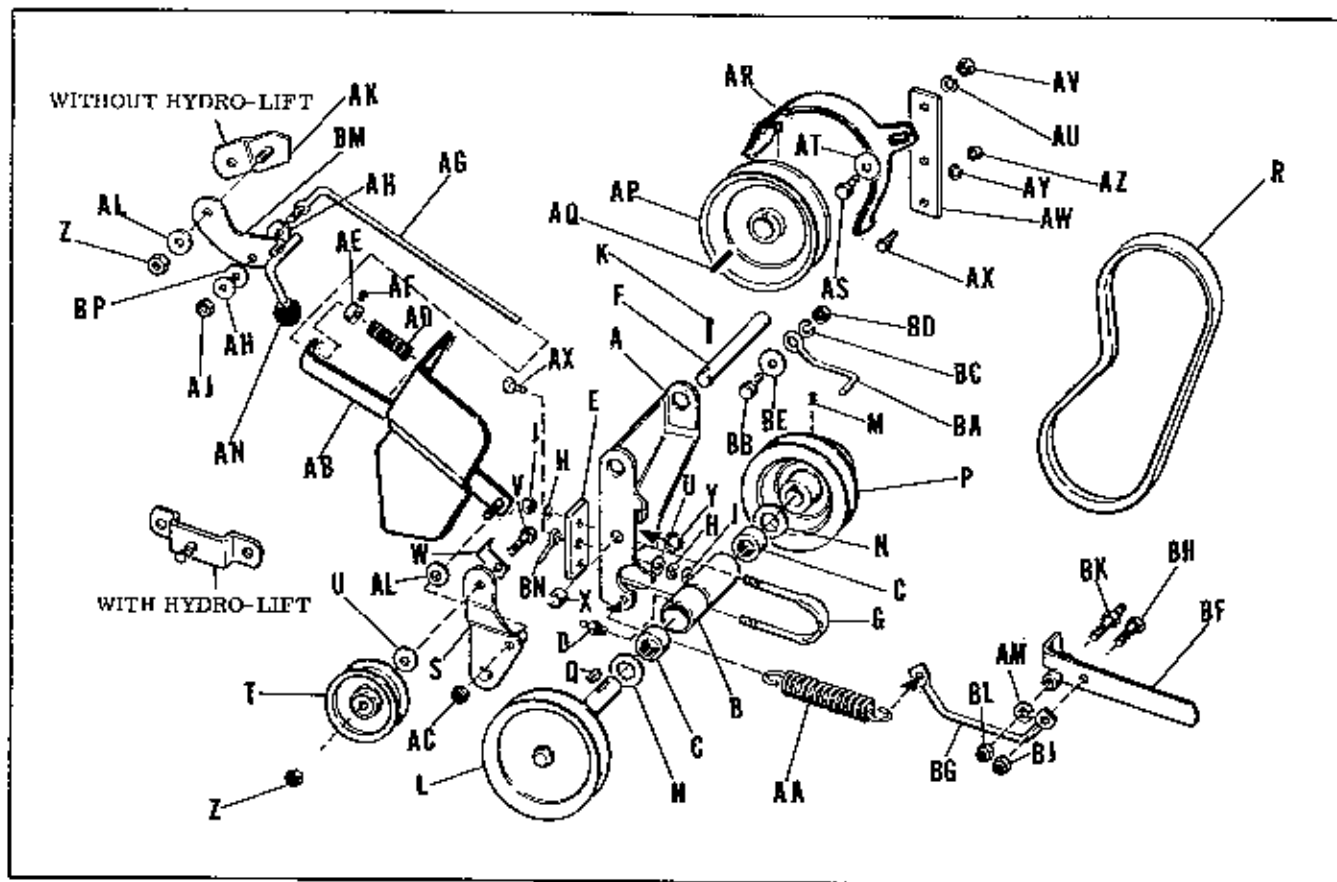

Figure 6

157292

## POWER TAKE-OFF



Ref. Let.	Part No.	Description
A	157285	P.T.O. - Bracket
B	157269	Bearing Housing
C	154258	Needle Bearing
D	727001	Grease Fitting
E	157472	Support Plate
F	154233	Pivot Rod, 5/8" Dia. x 6-13/16"
G	157270	"U" Bolt
H	720001	Lock Washer, 5/16"
J	717001	Full Hex. Nut, 5/16"-18
K	722007	Cotter Pin, 3/16" Dia. x 1-1/2"
L	157266	Shaft Assembly, P.T.O.
M	713503	Set Screw, 5/16"-18 x 5/16"
N	9061012	Washer
P	157116	P.T.O. Pulley
Q	725008	Weddruff Key #9-3/16" x 3/4"
R	164146	"V" Belt
S	157263	Idler Lever Assembly
T	154534	Idler Pulley
U	719002	Plain Washer, 5/16"
V	705016	Hex. Cap Screw, 3/8"-16 x 1-1/4"
W	157423	Stop
X	157272	Spacer
Y	157288	Retaining Ring
Z	717510	Full Hex. Nut, 3/8"-16
AA	157262	Tension Spring
AB	164153	Rod Guide Assembly
AC	717510	Full Lock Hex. Nut, 3/8"-16
AD	8191045	Spring
AE	8191022	Set Collar
AF	713001	Set Screw, 1/4"-20 x 3/8"
AG	164149	Clutch Rod Assembly

Ref. Let.	Part No.	Description
AH	719002	Plain Washer, 5/16"
AJ	717526	Full Lock Hex. Nut, 5/16"-18
AK	154362	Pivot Bar Assembly
AL	719001	Plain Washer, 3/8"
AM	720006	Lock Washer 7/16"
AN	122005	Knob
AP	157121	Pulley
AQ	8061081	Key
AR	164152	Belt Guard Assembly
AS	705005	Hex. Cap Screw, 3/8"-16 x 1"
AT	719001	Plain Washer, 3/8"
AU	720002	Lock Washer, 3/8"
AV	717003	Full Hex. Nut, 3/8"-16
AW	157050	Belt Guard Support
AX	705007	Hex. Cap Screw, 5/16"-18 x 1"
AY	720001	Lock Washer, 5/16"
AZ	717001	Full Hex. Nut, 5/16"-18
BA	161080	Belt Stop
BB	705007	Hex. Cap Screw, 5/16"-18 x 1"
BC	720001	Lock Washer, 5/16"
BD	717001	Full Hex. Nut, 5/16"-18
BE	719002	Plain Washer, 5/16"
BF	164155	Handle Assembly
BG	164047	Spring Tension Rod
BH	705017	Hex. Cap Screw, 5/16"-18 x 3/4"
BJ	717511	Full Lock Hex. Nut, 5/16"-18
BK	157273	Stud
BL	717519	Full Lock Hex. Nut, 7/16"-14
BM	154356	Clutch Lever Assembly
BN	121044	Belt Guide
BP	159134	Special Washer

## LUBRICATION

The Power Take-Off is lubricated by means of one Grease Fitting located on the bottom front of the Drive Bracket Assembly. Occasionally apply grease by means of a standard grease gun loaded with automotive type grease. Be sure to wipe dirt and grit from grease fitting before applying grease gun. Lubricate all pivot points and Idler Pulley Bearings with SAE 20 oil every few hours of operation.

## OPERATION

Operation of the Power Take-Off is controlled by movement of the Clutch Lever Assembly. See Figure 4. When the Clutch Lever is in the forward raised position, the Clutch Rod releases the tension holding the Idler Pulley against the Drive Belt, and power will not be transmitted to the driven pulley of the Power Take-Off Assembly. When the Clutch Lever is in the back, depressed position, the Clutch Rod applies tension to the Idler Pulley and as the Idler Pulley takes up the slack in the Drive Belt, power is transmitted from the Drive Pulley on Bevel Gear Box Shaft to the driven pulley of the Power Take-Off. Figure 4 shows Clutch Lever in Drive position.

## ADJUSTMENT

At points "A" and "B" of Figure 4, check tightness of Hex. Nut to be sure that Clutch Lever Assembly and Clutch Rod are free to pivot without binding.

Place Clutch Lever in "Drive" position and observe clearance between collar "C" (Figure 4) and end of bracket. When implement is attached to tractor, this clearance should normally be approximately  $3/4$ " ; at this setting the Idler Pulley should be snugly against the Drive Belt. If additional tension is required, release Clutch Lever and loosen Set Screw on Collar and Slide Collar farther back on Clutch Rod. Retighten Set Screw in Collar and put Clutch Lever in Drive position. Recheck clearance. The tension of the Idler Pulley against the Drive Belt must be sufficient to operate whichever tractor attachment is being used. Any additional tension is unnecessary and will only cause premature failure of Belts and Idler Pulley bearings.