

Simplicity[®]

**DEUTZ
ALLIS**

4200H & 600H SERIES LAWN TRACTORS

11HP Hydro Models

| Mfg No. | Description |
|----------------|--------------------|
| 1690759 | 4211H, 11HP Hydro |
| 1690846 | 4211H, 11HP Hydro |
| 1690912 | 4211H, 11HP Hydro |
| 1691029 | 4211H, 11HP Hydro |
| 1691037 | 4211H, 11HP Hydro |
| 1691079 | 611H, 11HP Hydro |

12HP Hydro Models

| Mfg No. | Description |
|----------------|--------------------|
| 1691271 | 4212H, 12HP Hydro |
| 1691276 | 612H, 12HP Hydro |

36" Mower Decks

| Mfg No. | Description |
|----------------|--------------------|
| 1690274 | 36" Mower Deck |
| 1690838 | 36" Mower Deck |
| 1691127 | 36" Mower Deck |

REPLACEMENT OPERATOR'S MANUAL

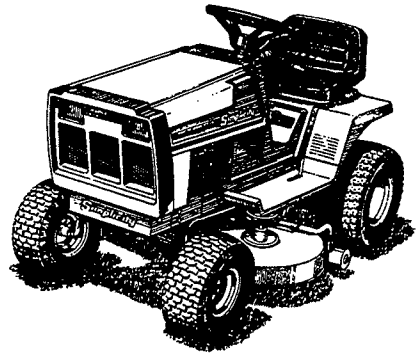

1700078-03
1700091-03
9/1986

TP 100-1514-01-LT-SA



Table of Contents

| | | | |
|---|-----------|---|-----------|
| TO OUR DEALERS | A | CLEANING THE BATTERY & CABLES | 13 |
| TO OUR CUSTOMERS | B | SHARPENING & BALANCING THE BLADES | 14 |
| USER'S RESPONSIBILITY | C | CHECK TRANSMISSION FLUID LEVEL | 15 |
| WARRANTY | D | TRACTOR OFF-SEASON STORAGE | 16 |
| SAFETY RULES | 2 | MOWER OFF-SEASON STORAGE | 16 |
| DECALS | 4 | STARTING AFTER STORAGE | 16 |
| MOWER INSTALLATION AND REMOVAL | 5 | TROUBLESHOOTING AND REPAIR | 17 |
| OPERATION | 7 | BATTERY REPLACEMENT | 19 |
| CONTROLS | 7 | JUMP STARTING | 20 |
| PUSHING THE TRACTOR BY HAND | 8 | TRACTOR BELT REPLACEMENT | 22 |
| BEFORE OPERATING | 8 | MOWER BELT REPLACEMENT | 24 |
| STARTING THE ENGINE | 8 | ADJUSTMENTS | 25 |
| MOWER PATTERN AND TIPS | 9 | TRACTOR BRAKE | 25 |
| NORMAL CARE | 10 | ENGINE PULLEY BELT STOPS | 25 |
| LUBRICATING THE TRACTOR | 11 | NEUTRAL ADJUSTMENT | 26 |
| CHECKING/ADDING GASOLINE | 11 | TRANS. CONTROL LEVER | 26 |
| CHECKING TIRE PRESSURE | 12 | TRANS. ENGAGE. LEVER | 26 |
| LUBRICATING THE MOWER | 12 | MOWER ADJUSTMENTS | 27 |
| CHECKING THE FUEL FILTER | 12 | | |
| CHECKING BATTERY FLUID | 13 | | |

NOTE

In this manual "left" and "right" are referred to as seen from the operating position.

Safety Rules



Read these safety rules and follow them closely. Failure to obey these rules could result in loss of control of vehicle, severe personal injury to yourself or bystanders, or damage to property or equipment. The triangle  in the text signifies important cautions or warnings which must be followed.

GENERAL

- Read the Operator's Manual carefully. Be thoroughly familiar with the controls and the proper use of the equipment.
- Never allow children to operate the machine. Do not allow adults to operate it without proper instruction.
- Do not carry passengers.
- Use only attachments or accessories designed for your machine. See your dealer for a complete list of recommended attachments or accessories.
- Keep the area of operation clear of all persons, particularly small children, and pets.
- Never direct discharge of material toward bystanders.
- Make sure:
 - a. tractor and attachments are in good operating condition,

- b. all safety devices and shields are in place and in good working condition, and
- c. all adjustments are correct.

PREPARATION

- Handle gasoline with care - it is highly flammable.
 - a. Use approved gasoline container.
 - b. Never remove the fuel tank cap or add gasoline to a running or hot engine, or fill the fuel tank indoors. Wipe up spilled gasoline.
- Do not run the engine indoors. Exhaust fumes are deadly.
- Clear the work area of objects which might be picked up and thrown by attachments.
- Disengage all attachment clutches and move transmission control lever into neutral before attempting to start the engine.

- Wear heavy footwear. Do not operate tractor when barefoot or when wearing open sandals or canvas shoes.

OPERATION

- Engage the parking brake, disengage the PTO, lower the attachment, stop the engine and remove the key before leaving the operator's position for any reason, such as to unclog attachment chutes or to make repairs or adjustments.
- Stop tractor and attachments and inspect for damage after striking a foreign object. Repair any damage before restarting and operating the equipment.
- Watch out for traffic when crossing or operating near roadways.
- Operate only in daylight or in good artificial light.
- Never make adjustment while the engine is running.
- After operation, place transmission control lever in forward position to help prevent accidental starting.

- Operate only up and down the face of slopes; never across the face. Do not stop or start suddenly on slopes.

- Reduce speed on slopes and in sharp turns to prevent tipping or loss of control. Use extreme caution when changing direction on slopes.

- Be especially careful not to touch tractor or attachment parts which might be hot from operation. Allow such parts to cool before attempting to maintain, adjust, or service.

- Stay alert for holes in the terrain and other hidden hazards. Be extra careful when operating on wet, slippery surfaces.

- If equipment begins to vibrate abnormally, disengage power to attachments and stop engine at once. Inspect for damage and correct before starting up tractor.

- Use care when pulling loads or using heavy equipment.

- a. Use only drawbar hitch point.

- b. Limit loads to those you can safely control.

- c. Do not turn sharply. Use care when backing.

- d. Use weights when recommended in the tractor or attachment Operator's Manual.

- Disengage power to attachment(s) when transporting or not in use.

MAINTENANCE & STORAGE

- Keep all nuts, bolts, and screws tight to be sure the equipment is in safe working condition.

- Do not change the engine governor settings or overspeed the engine.

- To reduce fire hazard, keep the engine free of grass, leaves, and excess grease.

- Never store the equipment with gasoline in the tank inside a building where fumes may reach an open flame or spark. Allow the engine to cool before storing in any enclosure.

DECALS

ALL WARNINGS, CAUTION, and instructional messages on your tractor and mower should be carefully read and obeyed. Personal bodily injury can result when these instructions are not followed. The information is for your safety and it is important. The safety messages on this page are on your tractor and mower.

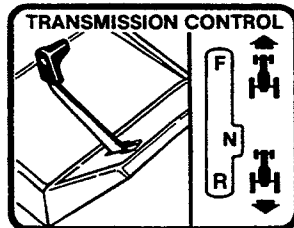
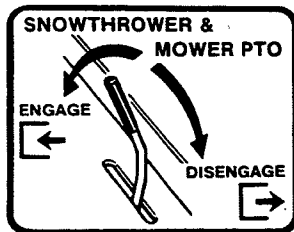

CAUTION

- Before operating, read safety and operating instructions in Operator's Manual.
- Keep all shields in place.
- Keep hands, feet and clothing away from power driven parts.
- Keep people and pets a safe distance from machine.
- Never carry riders.
- Do not operate where machine can slip or tip.
- Look behind machine before backing up.
- To start engine operator must; be in seat, set parking brake, shift transmission into neutral and disengage PTO.

Before leaving operator's position:

- Set parking brake.
- Disengage PTO clutch.
- Shut off engine and remove key.
- Wait for all movement to stop before placing hands or feet near blades.

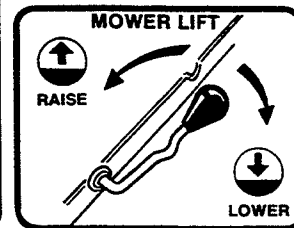
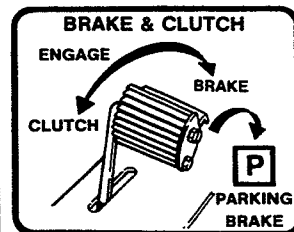

DANGER

Diagram showing a hand and foot near a rotating cutting blade.

ROTATING CUTTING BLADE

- Do not put hands or feet under mower deck or into discharge chute.
- Do not operate mower without discharge chute or entire grass catcher in place.

Objects may be thrown from mower.

- Clear lawn of debris and objects.
- Do not mow with bystanders in area.

DANGER

Diagram showing a hand and foot near a rotating cutting blade.

ROTATING CUTTING BLADE

- Do not put hands or feet under or into any part of this mower deck while blade is rotating.

Diagram showing a hand near a transmission lever with arrows for 'TRANSMISSION ENGAGE' and 'TRANSMISSION DISENGAGE'.

IMPORTANT: Do not tow tractor. Damage to transmission will result. Disengage transmission to manually push tractor.

Mower Installation & Removal



WARNING

Engage the parking brake, disengage the PTO, stop the engine and remove the key before attempting to install or remove the mower.

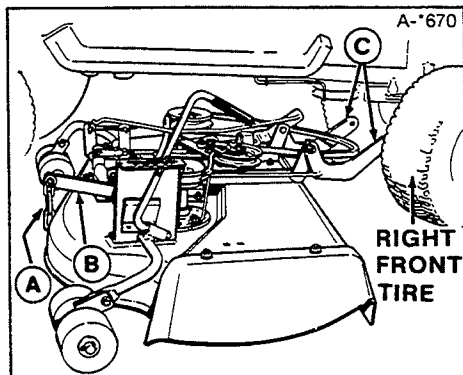

Figure 1. Installing 36" Mower

- | | |
|---------------|---------------------|
| A. Lift Chain | C. Mower Hitch Arms |
| B. Lift Arm | |

NOTE

The lift chain (A, figure 1) should be connected to the rear hole in lift arm (B) unless optional large lift lever (B, figure 8) is used to raise mower. With large lift lever, connect chain in forward hole.

1. Place your tractor on a level surface, with the mower on the right side of the tractor.
2. Turn the tractor front wheels full left (figure 1).
3. Place the mower in lowest cutting position and slide it under the tractor,

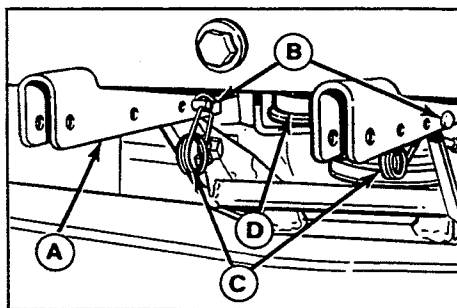

Figure 2. Mower Hitch Attached

- | | |
|----------|-----------------|
| A. Hitch | C. Safety Clips |
| B. Pins | D. Drive Belt |

aligning arms (C, figure 1) with tractor hitch (A, figure 2).

4. Insert the link (A, figure 3) into lift arm (B) then pivot back and down. Secure chain (C) to clevis (D) with pin (E) and clip (F). (Early models are equipped with a simple hook instead of clevis assembly shown in figure 3.) If chain has four links, be sure to use only three links.

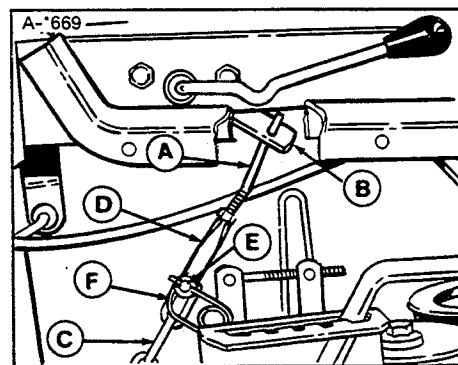

Figure 3. Lift Assembly

- | | |
|--------------|-----------|
| A. Lift Link | D. Clevis |
| B. Lift Arm | E. Pin |
| C. Chain | F. Clip |

6. Slip the mower drive belt onto the PTO pulley (C, figure 4). Loosen belt stops as necessary. The left-hand belt stop (A) is shown in figure 4. The right-hand belt stop is shown in figure 5. Check routing of belt by referring to figure 6.
7. Insert one end of the PTO rod (B, figure 7) in the mower PTO arm (A) and the other end in the tractor PTO arm (C) in hole marked "MOW". The rod must be inserted into the holes from the right-hand side as shown. Refer to figure 7 to make sure the rod is correctly positioned. Install the spring clips (D).

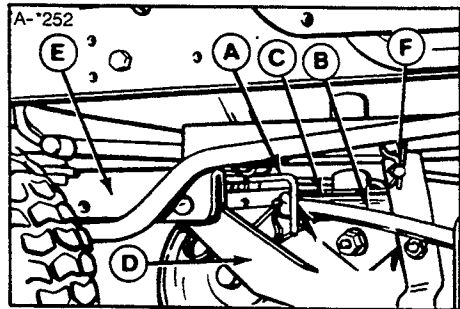

Figure 4. Left-Hand Belt Stop

- | | |
|---------------|--------------------|
| A. Belt Stop | D. Mower Hitch Arm |
| B. Belt | E. Tractor Hitch |
| C. PTO Pulley | F. Spring Clip |

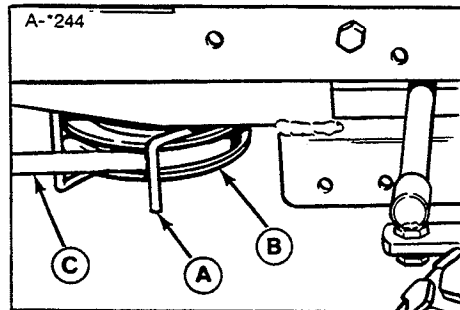

Figure 5. Right-Hand Belt Stop

- A. Belt Stop B. PTO Pulley C. Belt

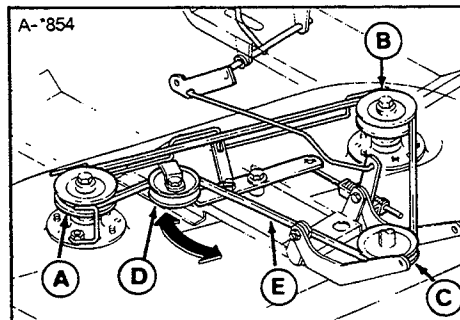

Figure 6. Mower Belt Pattern - 36"

- | |
|--|
| A. V-Pulley, Right Arbor |
| B. V-Pulley, Left Arbor D. Flat Idler Pulley |
| C. Engine PTO Pulley E. Belt |

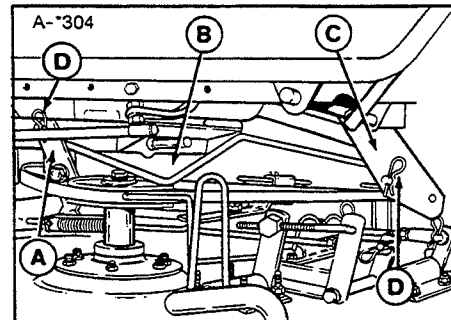

Figure 7. Installing PTO Rod

- | |
|--------------------|
| A. Mower PTO Arm |
| B. PTO Rod |
| C. Tractor PTO Arm |
| D. Spring Clip |

8. If installing mower for the first time, or if a new belt was installed, perform the mower adjustments in the Adjustments section.
9. Reverse the procedure to remove the mower.

Operation

CONTROLS

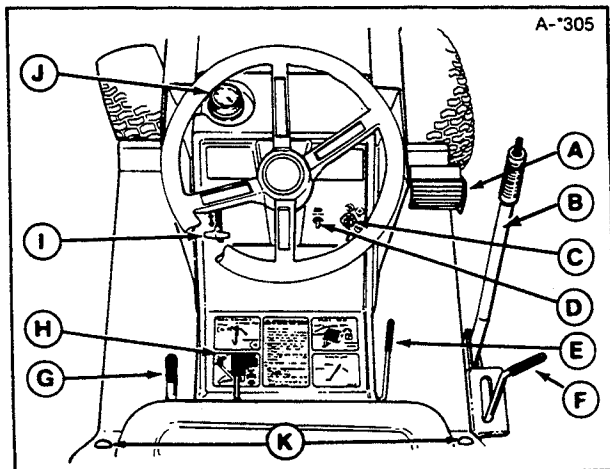

Figure 8. Tractor & Mower Controls

INTERLOCK SWITCHES

This tractor is equipped with a seat switch which will stop the engine if operator leaves seat when PTO is engaged and/or transmission is in gear. Also, switch will prevent starting if operator is not in seat. The PTO must be disengaged and transmission in NEUTRAL to start engine.

| Ref. | Name | Function |
|------|----------------------------|---|
| A | Clutch-Brake | Disengages tractor clutch when pressed down at least halfway. Applies brake when fully depressed. Engages parking brake when latched over footrest. |
| B | Lift Lever | Lifts and holds attachments in transport position (only required with attachment other than mower).(Optional) |
| C | Ignition Switch | Operates with key to start, run, or stop engine. |
| D | Light Switch | Switches headlights on or off (if equipped). |
| E | Mower Lift Lever | Lifts and holds mower in transport position. |
| F | Mower Height Control Lever | Adjust mower cutting height. |
| G | PTO (Power Take Off) Lever | Engages and disengages power to attachments. Pull back to disengage. |
| H | Transmission Control Lever | Controls ground speed and forward/reverse motion. Push toward left to move out of neutral (center) position. Push down to go forward. Pull up to go rearward. |
| I | Engine Speed Control | Position from SLOW to FAST to control engine speed. Also position for engine CHOKE. |
| J | Gas Gauge/ Cap | Shows amount of gasoline in the tank and serves as tank cap. |
| K | Seat Deck Latch | Press button on each side to tilt the seat deck back. |



CAUTION

Do not tow tractor. Transmission damage may result.

PUSHING THE TRACTOR BY HAND

Never push the tractor faster than walking speed. To push, the transmission must be disengaged. To do this, raise the seat deck to expose the transmission engagement lever. Push the lever forward to disengage the transmission. Pull toward left and pull lever back to engage the transmission.

BEFORE OPERATING

1. Refer to Normal Care Chart and perform any needed care.
2. Clear the work area of any objects which may be caught in or thrown by the attachment.

STARTING THE ENGINE

1. Set the parking brake.
2. Place transmission control lever in NEUTRAL. The lever will snap into NEUTRAL notch when moved to center position.
3. Lift the PTO lever fully back to disengage the attachment.

4. Set engine speed control lever in CHOKE position. (A warm engine may not require choking).
5. Insert the key into ignition switch and turn to START. Release when engine starts.
6. Move the throttle out of CHOKE position.

STARTING & STOPPING OPERATION

1. Start the engine as described in previous procedure.
2. Place the engine speed control lever between 3/4 and full speed. Full engine speed is recommended, especially if mowing thick grass or blowing heavy snow.
3. Release the parking brake by depressing pedal and unlatching from end of footrest.
4. If possible, the first motion should be straight forward or back. Position the front wheels straight ahead.
5. To go forward, move transmission control lever to left to move out of neutral then press downward. The farther downward you press, the faster forward ground speed.
To go rearward, move transmission

control lever to left to move out of neutral then pull up. The farther upward you pull lever, the faster rearward ground speed.

6. Select the appropriate ground speed for conditions. If the terrain is rough, hilly or sloping, drive slowly. You should also drive slowly to cut thick grass or blow heavy snow. On level ground, with light grass or snow, you can use full speed.
7. Use the transmission control lever to slow down for turns or to trim around objects, then increase speed.
8. **To stop**, move the transmission control lever into NEUTRAL position. **For a more rapid stop**, depress the clutch-brake pedal. If you stop by depressing the pedal, move control lever to NEUTRAL before releasing pedal.
9. Before leaving the operator seat:
 - a. Stop tractor motion and engage parking brake.
 - b. Disengage the PTO and lower the attachment.
 - c. Set engine speed control to SLOW. Stopping a hot engine too fast may cause engine damage. Let engine idle

for about a minute.

d. Turn key to OFF and remove it.



WARNING

Before leaving the operator's position for any reason, engage the parking brake, disengage the PTO, stop the engine and remove the key.



WARNING

Never operate on slopes greater than 30 percent (16.7°) which is a rise of three feet vertically in 10 feet horizontally. When operating on slopes that are greater than 15 percent (8.5°) but less than 30 percent use rear wheel weights (see your dealer). Select slow ground speed before driving onto slope. Mow UP and Down the slope, never across the face, use caution when changing directions and DO NOT START OR STOP.



WARNING

To reduce fire hazard, keep the engine, tractor and mower free of grass, leaves and excess grease.

MOWING PATTERN & TIPS

For the first use of the mower choose a smooth level area. Cut long straight strips overlapping slightly.

The size and type of area to be mowed determine the best mowing pattern to use. Obstructions such as trees, fences and buildings must also be considered. Where possible, make one or two passes in a clockwise direction around the outside of the area to keep cut grass off fences and walks. The remainder of the mowing should be done in a counterclockwise direction so the clippings are dispersed on the cut area.

Where possible, keep the left side of the mower toward trees, posts, or other obstacles on the first pass around the obstacles to keep hand trimming to a minimum.

On moderate size, frequently mowed lawns

where grass is light and dry, it is sometimes practical to mow in a clockwise direction so that clippings are thrown toward the center of the lawn and concentrated for pickup and removal.

Most lawns should be mowed to keep the grass approximately two to three inches (50 to 76 mm) high. Best results are obtained by cutting often and not too short. To help keep a green lawn, never mow more than one third off the height of the grass, or a maximum of one inch (25 mm), in one mowing. For extremely tall grass, set the cutting height at maximum for the first pass, and then reset to the desired height and mow again.

On thick, or springy grass or soft ground, the mower rollers sink into the ground giving too low a cut. Adjust the cutting height as necessary. For best appearance, grass should be cut in the afternoon or early evening (in daylight) where it is free of external moisture.

Where possible, change patterns occasionally to eliminate matting, graining or a corrugated appearance.

Normal Care

NORMAL CARE SCHEDULE

A schedule for normal care is provided in Table 1. If your tractor is not equipped with an optional hourmeter, you will need to keep a record of operating time.

RAISING HOOD & SEAT DECK

To raise the hood, grasp both sides of the hood near the dash. Pull sides of hood outward and tilt the hood forward.

To raise the seat deck, position yourself as shown in figure 9. Press both buttons and tilt the seat deck back.

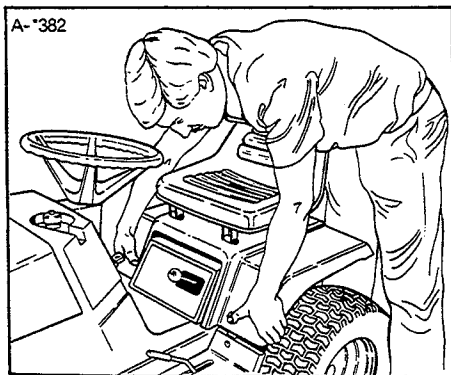

Figure 9. Opening the Seat Deck

| Care Required | Schedule | | | | | |
|--|-----------|------------------|-----------------|---------------|-------------------|---------------------------|
| | See | Before First Use | Before Each Use | Every 5-Hours | ** Every 25 Hours | Every 100 Hours or Yearly |
| Check gas gauge | P. 11 | • | • | | | |
| Check for loose nuts, screws, oil leaks, etc. Clean grass from mower. | | • | • | • | | |
| Check engine oil level | Eng. Man. | • | • | • | | |
| Clean engine & air filter | Eng. Man. | | | | • | |
| Change engine oil* | Eng. Man. | | | | • | |
| Lubricate tractor & mower | P. 11, 12 | • | | | • | |
| Service battery | P. 13 | • | | | • | |
| Check tire pressures | P. 12 | • | | | • | |
| Sharpen/balance blade | P. 14 | | | | | • |
| Inspect spark plug(s) | Eng. Man. | | | | | • |
| Check fuel filter | P. 12 | | | | | • |
| Check transmission fluid | P. 15 | • | | | • | |
| *Change original engine oil after first 5 hours of operation. | | | | | | |
| **More often in hot (over 85°F; 30°C) weather or dusty operating conditions. | | | | | | |

Table 1. Schedule of Normal Care - Tractor & Mower

LUBRICATING THE TRACTOR

Lubricate the tractor as shown in figures 10 thru 12. When a grease gun is shown, wipe the fitting clean, apply two or three shots of Lithium grease, and wipe off excess grease. When an oil can is shown wipe the area clean, apply a few drops of oil (SAE 30), then wipe up drips or spills. Keep oil off belts, brake pads, and pulleys.

CHECKING/ADDING GASOLINE

Check the gas gauge/cap to be sure there is enough gasoline to complete the job. To add gasoline, remove the gas gauge/cap. Refer to your engine manual for gasoline recommendations. Install and hand tighten the gas gauge/cap.

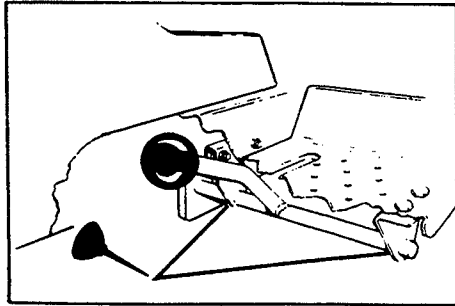

Figure 10. PTO Lever Lubrication

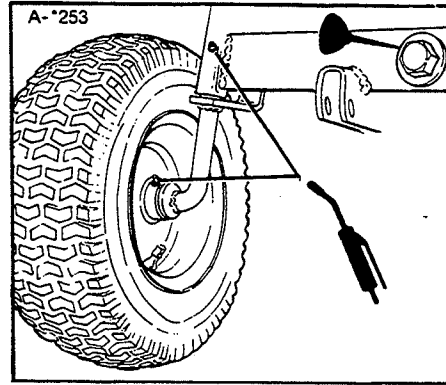

Figure 11. Front Axle Lubrication
(Two grease fittings on each side)

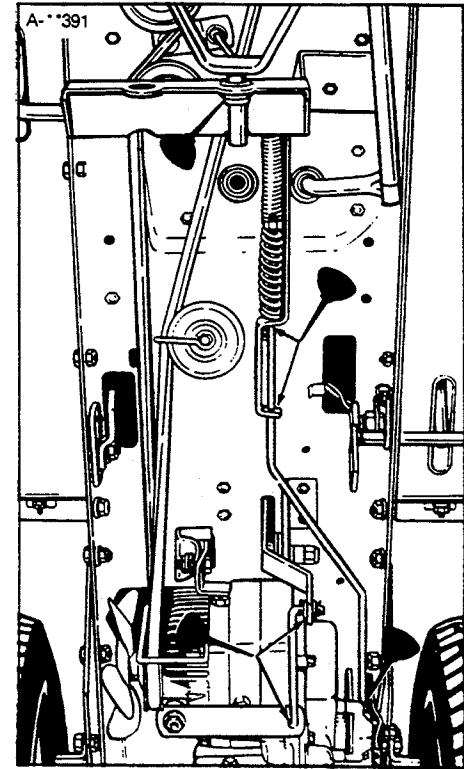

Figure 12. Clutch & Brake Rod
Lubrication
(Underneath tractor)

CHECKING TIRE PRESSURE

Check air pressure of all four tires. Front tires should be 12 to 15 psi. Rear tires should be 6 to 8 psi. A gauge with one-pound markings will be necessary for an accurate check.

LUBRICATING THE MOWER

Lubricate the mower as shown in figures 13 thru 15. Use an oil can with medium weight (SAE 30) oil. Brush and wipe dirt and grass from the area before applying oil. Wipe up drips and spills. Keep oil off belts and pulleys.

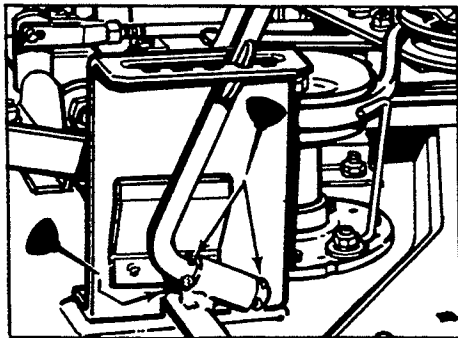

Figure 13. Lubricate Height Control Lever & Point Where Roller Bar Contacts Bracket.

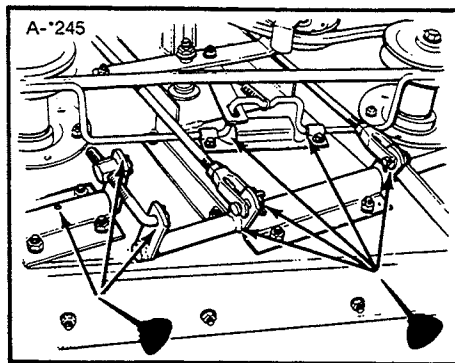

Figure 14. Lubricate Brake Lever, Clevises & Levelling Rod.

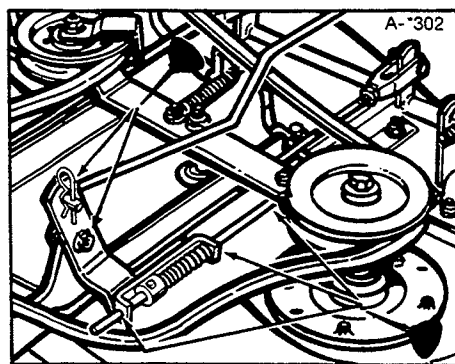

Figure 15. Lubricate Hitch, PTO Rod and PTO Arm

CHECKING THE FUEL FILTER



WARNING

Do not remove fuel filter when engine is hot, as spilled gasoline may ignite. Do not spread hose clamps further than necessary. Insure clamps grip hoses firmly over filter after installation.

The fuel filter is located in fuel line between fuel tank and carburetor. If filter is dirty or clogged, replace as follows. Place a container below filter to catch spilled gasoline.

1. Using a pliers, open and slide hose clamps from fuel filter.
2. Remove hoses from filter.
3. Install new filter in proper flow direction in fuel line. Secure by reclamping with hose clamps. See warning at beginning of procedure.

SERVICING THE BATTERY

Checking Battery Fluid

1. Raise the seat.
2. Remove filler caps, one at a time.
3. Fluid must be even with split ring full mark (figure 16). If not, add distilled water.
4. Reinstall filler caps.



WARNING

Be careful when handling the battery. Avoid spilling electrolyte. Keep flames and sparks away from the battery.



WARNING

When removing or installing battery cables, disconnect the negative cable **FIRST** and reconnect it **LAST**. If not done in this order, the positive terminal can be shorted to the frame by a tool.

Cleaning the Battery & Cables

1. Disconnect the cables from the battery, negative cable first (figure 16).
2. Remove the battery clamp, then remove the battery.
3. Scrub the battery, cables, and battery compartment with baking soda and water.
4. Clean the battery terminals and cable clamps with a wire brush.
5. Reinstall battery and clamp (figure 16).
6. Connect cables, positive cable first.
7. Coat cable clamps and terminals with grease or petroleum jelly.

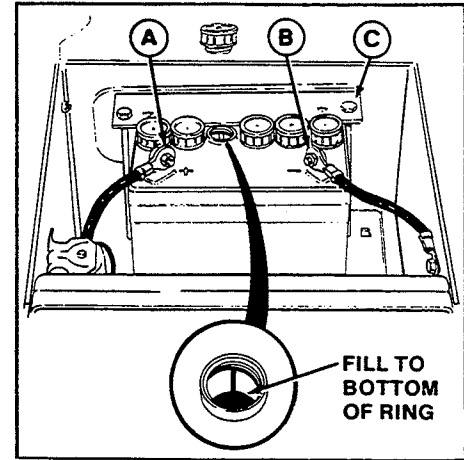

Figure 16. Battery

- A. Positive Terminal
- B. Negative Terminal
- C. Battery Clamp

SHARPENING & BALANCING THE BLADES

1. Remove mower from tractor and position as in figure 17. Secure the mower so it will not fall.
2. Remove dirt and foreign matter.
3. Use wooden block to hold blade while removing capscrew (figure 17).
4. Sharpen the blade with a file. Remove nicks and dents in blade edge. If blade is damaged, it should be replaced.



WARNING

Blade mounting capscrews must be installed with the cup washer and spline washer and then securely tightened. Torque blade mounting capscrews to 55 ft. lbs. (74 N.m).



WARNING

Do not handle the mower blades with bare hands. Avoid touching the cutting edge. Careless or improper handling of blades may result in serious injury.

5. Check and balance blade. Use a balancing machine or the fixture shown in figure 18. Center the blade on a nail lubricated with a drop of oil. A balanced blade will remain level. File material off heavier end of blade until it is balanced.
6. Reinstall each blade with the tabs pointing up toward deck and secure with a capscrew, cup washer, and spline washer. Be sure all splines are aligned and washer is flush against blade. Use a wooden block to prevent blade rotation

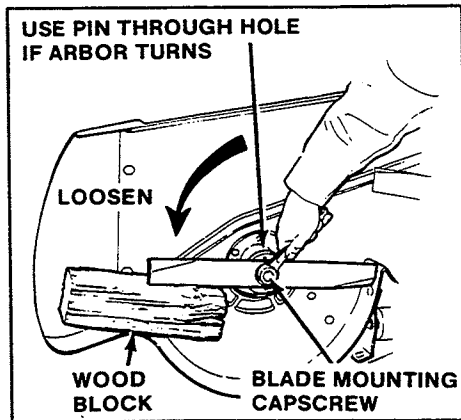

Figure 17. Removing Blade

and torque capscrew to 55 ft. lbs. (74 N.m.) (figure 19).

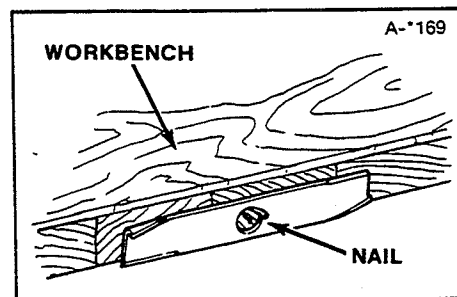

Figure 18. Balancing Blade

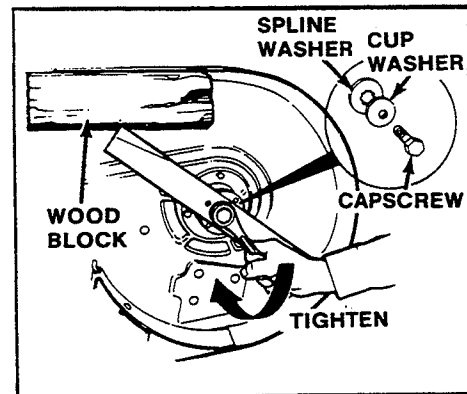

Figure 19. Installing Blade

CHECK TRANSMISSION FLUID LEVEL

There are two fluid levels that must be checked. The Hydrostatic Transmission and the Differential fluid level. Proceed as follows.

Hydrostatic Fluid Level

1. Allow tractor to cool after operation. Fluid must be cool for an accurate check.
2. Raise the seat deck.
3. The fluid level is visible in the reservoir (figure 20) without removing cap. The level should be at COLD level mark. If not, go to step 4.
4. Remove the reservoir cap. Add oil (see your dealer). Remove inspection plug (B, figure 20) when adding oil to reservoir. If the oil is black or milky, see your dealer to determine cause.
5. It will take a while for the oil to seep thru a filter screen into the reservoir. Check the level again after operating the tractor a few times. If level is

consistently low, see your dealer to check for leaks.

Differential Fluid Level

1. The check plug is located on the front of the differential. For this reason, it would be easier to check the fluid in the spring before installing the mower or in the fall after removing the mower.
2. Remove the check plug (figure 21) by turning counterclockwise. Oil level

should be at bottom of hole. If not, add oil (see your dealer).

3. Reinstall the check plug.

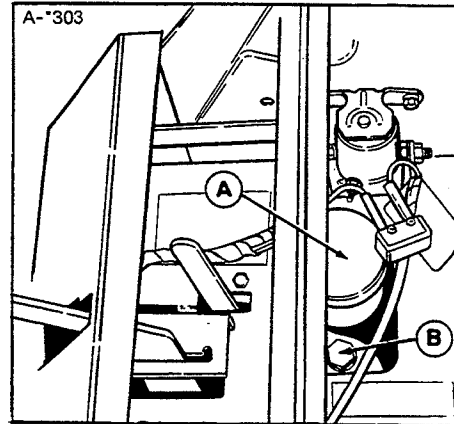

Figure 20. Hydrostatic Reservoir

A. Reservoir B. Inspection Plug

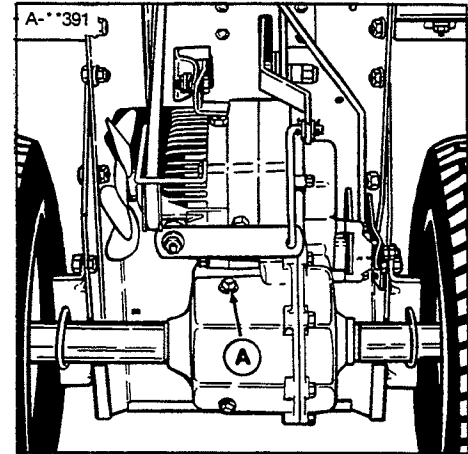

Figure 21. Differential Check Plug

A. Check Plug (viewed from underneath)

TRACTOR OFF-SEASON STORAGE

When the tractor is to be stored for two months or longer, take precautions as follows:



WARNING

Gasoline is highly flammable. Keep open flame or spark away from gasoline and fuel tank. Never store tractor where gasoline fumes may reach an open flame or spark.

1. To empty or prepare fuel tank:
 - a. Run tractor engine until it stops from lack of fuel, or;
 - b. Use a gasoline stabilizer. This additive, available from your dealer, prevents formation of gum and varnish for up to one year. With the additive, fuel may remain in your tank for long periods.
2. Change engine oil while the engine is still warm. Record the type and weight of oil put in crankcase.
3. Remove spark plug(s). Pour one ounce (30 ml) of SAE 30 oil into engine

through spark plug hole(s). Crank engine a few times to distribute oil and then reinstall the spark plug(s).

4. Lubricate the tractor.
5. Check battery fluid level. Battery life will be extended if it is removed and stored in a cool, dry place, and fully charged.
6. Clean tractor thoroughly. Coat all exposed bare metal parts with a good quality paint (obtainable from your dealer) or a light film of grease or oil.

MOWER OFF-SEASON STORAGE

To protect your mower, store it in an enclosed dry area. To prepare the mower for off-season storage perform the following.

1. Remove mower from tractor if tractor is to be used without mower. (See Mower Installation and Removal section).
2. Clean top and underside of mower to remove all grass and dirt.
3. Coat all bare metal surfaces with a good quality paint (available from your dealer) or a light coat of oil to prevent rusting.

4. Lubricate mower (page 12).
5. Check, sharpen and balance the mower blades (page 14).
6. The belt should be stored in a cool, dark place away from sunlight or any heat source.

STARTING AFTER STORAGE

1. Replace battery, if removed. Be sure terminals and clamps are clean.
2. Remove the spark plug and wipe dry. Crank engine a few times to blow excess oil out of plug hole. Reinstall the plug.
3. Fill fuel tank with fresh gasoline (unless a fuel stabilizer was used).
4. Clean engine fins and air filter. (See engine manual).
5. Check fluid levels and tire pressure. (See Normal Care Chart.)
6. Start the engine outdoors. Do not run engine at high speeds immediately after starting.

Troubleshooting & Repair

CONTENT OF SECTION

This section of the manual provides troubleshooting and repair instructions for the more common and easily corrected problems. For other problems, it is recommended that you contact your dealer.



WARNING

To avoid serious injury, perform maintenance on the tractor or mower only when the engine is stopped and the parking brake engaged. Always remove the ignition key and disconnect spark plug wire and fasten away from the plug before beginning the maintenance to prevent accidental starting of the engine.

TROUBLESHOOTING PROCEDURES

Troubleshooting procedures are provided in Table 2. To use these procedures, first locate the problem description that best describes the trouble that you have encountered. Check the possible causes one at a time in the order that they are listed.

1. Engine will not start.

- A. Transmission control lever not in NEUTRAL. Move into NEUTRAL.
- B. PTO clutch lever not disengaged. Disengage fully.
- C. Operator not seated. Operator must be in seat to start engine.
- D. Out of fuel. Refill fuel tank.
- E. Engine flooded. Move control out of choke & attempt to start.
- F. Circuit breaker tripped. Wait one minute for automatic reset. Replace if defective (see your dealer).
- G. Battery terminals require cleaning. See Normal Care section.
- H. Battery discharged or dead. Recharge or replace.
- I. Wiring loose or broken. Visually check wiring & replace broken or frayed wires. Tighten loose connections.
- J. Solenoid or starter motor faulty. Repair or replace.
- K. Safety interlock switch faulty. Replace if needed. (See your dealer).
- L. Spark plug or points faulty, fouled, or incorrectly gapped. Clean & gap or replace.
- M. Water in fuel tank. Drain fuel & refill with fresh fuel.
- N. Old stale gas. Drain fuel & replace with fresh fuel.

2. Engine starts hard or runs poorly.

- A. Fuel mixture too rich. Move control out of choke. If problem still exists, clean air filter.
- B. Carburetor adjusted incorrectly. See your engine manual.
- C. Spark plug or points faulty, fouled or incorrectly gapped. Clean and gap or replace.

Table 2. Troubleshooting

Troubleshooting

3. Engine knocks.

- A. Low oil level. Check/add oil as required.
 - B. Using wrong grade oil. See Normal Care section.
-

4. Excessive oil consumption.

- A. Engine running too hot. Clean engine fins, blower screen and air cleaner. See Normal Care section.
 - B. Using wrong weight of oil. See Normal Care section.
 - C. Too much oil in crankcase. Drain excessive oil.
-

5. Engine exhaust is black or smoky.

- A. Dirty air filter. Clean air filter.
 - B. Choke not fully open. Move control out of choke and be sure choke opens fully. If problem still exists, check carburetor adjustment.
-

6. Engine runs, but tractor will not drive or lacks power.

- A. Check fluid levels (transmission).
 - B. Drive belt slips. (See problem and cause below.)
 - C. Transmission control lever in NEUTRAL. Move into forward or reverse.
-

7. Drive belt slips.

- A. Pulleys or belt greasy or oily. Clean as required.
- B. Belt stretched or worn. Replace with correct belt.
- C. Clutch rod binding in guide. Oil clutch rod. See Tractor Lubrication.

8. Brake will not hold.

- A. Brake is incorrectly adjusted. See Adjustment section.
 - B. Brake pads worn & require replacement. See your dealer.
-

9. Tractor handles poorly.

- A. Steering linkage is loose. Check and tighten any loose connections.
 - B. Improper tire inflation. Check and correct.
 - C. Wheels are spinning and slipping. Use weights to provide additional stability and traction.
 - D. Moving too fast on slopes. Reduce speed.
-

10. Main tractor drive belt does not stop when clutch-brake pedal is depressed.

- A. Belt stops out of adjustment. See Adjustments section.
 - B. Linkage not operating properly.
-

TROUBLESHOOTING (MOWER)

1. Mower will not raise.

Lift chain not attached or broken. Attach or repair.

2. Uneven cut.

- A. Mower not leveled properly. See leveling adjustment in Mower Adjustment section.
 - B. Tractor tires not inflated equally or properly.
-

3. Mower cut is rough looking.

- A. Engine speed too slow. Set for three-fourths to full speed.
- B. Tractor ground speed too fast. Use lower gear.

3. Mower cut is rough looking (Cont'd).

- C. Blades dull & require sharpening. See Normal Care section.
- C. Mower drive belt slipping. Belt oily or worn. Clean or replace belt as necessary. Readjust belt tension.

4. Engine stalls easily with mower engaged.

- A. Tractor ground speed too fast. Use lower gear.
- B. Engine speed too slow. Set for three-fourths to full speed.
- C. Cutting height set too low when mowing tall grass. Cut tall grass at maximum cutting height during first pass.
- D. Discharge chute jamming with cut grass. Cut grass with discharge pointing toward previously cut area.

5. Excessive mower vibration.

- A. Blade mounting screws are loose. Torque to 55 ft. lbs. (74 N.m.). See Normal Care section.
- B. Mower blades, arbors, or pulleys are bent. Check and replace as necessary.
- C. Mower blades are out of balance. Remove, sharpen, and balance blades (see Normal Care section).

6. Excessive belt breakage.

- A. Belt tension too tight. Readjust belt tension.
- B. Bent or rough pulleys. Repair or replace.
- C. Using incorrect belt. See your dealer.

7. Mower drive belt slips or fails to drive.

- A. Mower drive belt out of adjustment. See Adjustment section.
- B. Mower drive belt broken. Replace belt. **Table 2. Troubleshooting (Cont'd)**

BATTERY REPLACEMENT

A dead battery or one too weak to start the engine may not mean the battery needs to be replaced. It may, as an example, mean that the charging system is not working properly or that the battery has lost its charge during storage. First, "Clean Battery & Cables" and "Check Battery Fluid Level". Have the battery recharged if necessary. If there is any doubt about the cause of the problem, see your dealer. If you must replace the battery, remove and install the battery as described in "Clean Battery & Cables".

JUMP STARTING WITH AUXILIARY (BOOSTER) BATTERY

Jump starting is not recommended. First, check the battery as described in "Battery Replacement" above. If jump starting must be done, follow these instructions. Both booster and discharged batteries should be treated carefully when using jumper cables. Follow exactly procedures one through five, being careful not to cause sparks.



WARNING

For your personal safety use extreme care when jump starting. Never expose battery to open flame or electric spark - battery action generates hydrogen gas which is flammable and explosive. Do not allow battery acid to contact skin, eyes, fabrics, or painted surfaces. Batteries contain a sulfuric acid solution which can cause serious personal injury or property damage.

1. Set parking brake and place transmission in "NEUTRAL". Turn off lights and other electrical loads.

2. Remove vent caps from both the booster and the discharged batteries. Lay a cloth over the open vent wells on each battery. These two actions help reduce the explosion hazard always present in either battery when connecting a "live" battery to a "dead" battery.
3. Attach one end of one jumper cable to the positive terminal of the booster battery (identified by a red color, "+" or "P" on the battery case, post or clamp) and the other end of same cable to positive terminal of discharged battery. DO NOT permit vehicles to touch each other, as this could establish a ground connection.
4. Attach one end of the remaining cable to the negative terminal (black color, "-" or "N") of the booster battery, and the other end to a bare metal surface on the frame of your tractor AWAY FROM the battery compartment (do not connect directly to negative post of dead battery). Take care that clamps from one cable do not inadvertently touch the clamps on the other cable. Do not lean over the battery when making this connection.

5. The tractor with the discharged battery should now start.

Reverse the jump starting procedure exactly to remove the jumper cables. Then reinstall the vent caps and throw the cloths away as they may have corrosive acid on them.



WARNING

Any procedure other than the above could result in: (1) personal injury caused by electrolyte squirting out of the battery vents, (2) personal injury or property damage due to battery explosion, (3) damage to the charging system of the booster vehicle or the immobilized vehicle.

Do not attempt to jump start a vehicle having a frozen battery because the battery may rupture or explode. If a frozen battery is suspected, examine all fill vents of the battery. If ice can be seen or if the electrolyte fluid cannot be seen, do not attempt to start with jumper cables as long as the battery remains frozen.

THIS PAGE INTENTIONALLY BLANK

TRACTOR DRIVE BELT REPLACEMENT



CAUTION

To avoid damaging belt, do not pry over pulleys.

1. Engage the parking brake by latching the pedal over the end of the footrest.
2. Loosen the PTO pulley belt stops (G, figure 22).
3. Either remove the mower, or slip the mower belt off the PTO pulley (F).
4. Remove the tractor belt from the engine pulley (A) and allow to rest on top of the PTO pulley.
5. Loosen the belt stop on the idler pulley (B) and remove the belt.
6. Remove the idler pulley (D) by removing capscrew and nut.
7. Remove the belt guide (I).
8. Remove the belt from the transmission pulley (E). Rotate fan with belt to remove belt.
9. Remove the belt from PTO pulley (F) and tractor.

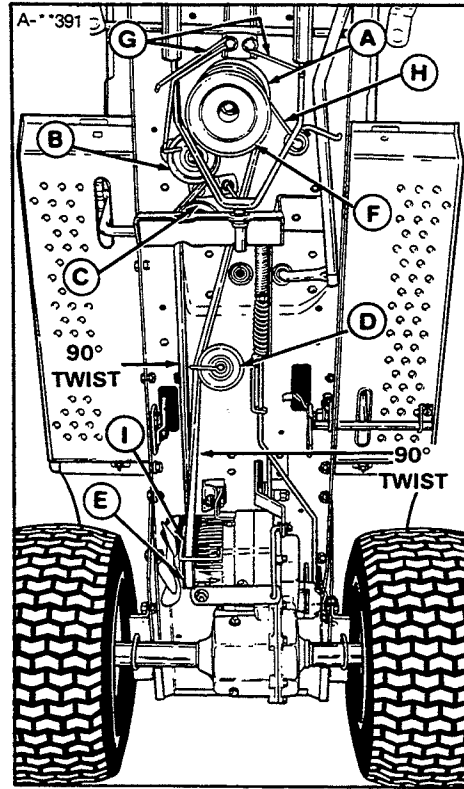

Figure 22. Tractor seen from underneath

10. Install the new belt by reversing the procedure. Be sure the V side of the belt is against all the pulleys except the flat idler pulleys (B and D). There are only two twists in the belt, as shown in figure 22. The belt diagram is shown in figure 23.
11. Refer to figure 24 to reinstall the middle idler pulley. Position flat side of belt against the pulley, position the belt guide (E, figure 24) and hardware, and install as shown. Make sure pulley can rotate freely after installation.
12. Perform "Tractor Brake Adjustment" and "Engine Pulley Belt Stops Adjustment" (page 25).

- A. Engine Pulley
- B. Pulley, Flat
- C. Idler Pulley
- D. Idler Pulley, Flat
- E. Transmission Pulley
- F. PTO Pulley
- G. PTO Pulley Belt Stops
- H. Belt Stops, Engine Pulley
- I. Belt Guide

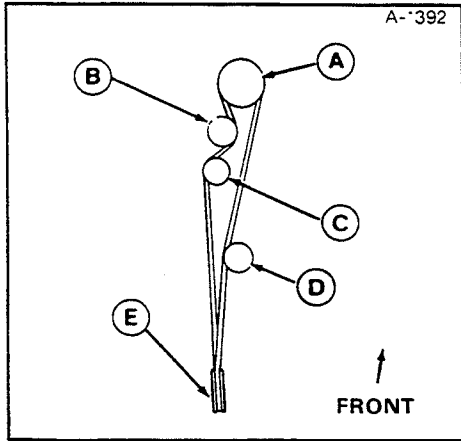

Figure 23. Belt Diagram

- A. Engine Pulley
- B. Idler Pulley
- C. Idler Pulley
- D. Idler Pulley, Middle
- E. Transmission Pulley

NOTE

Reference letters in Figure 23 are same as reference letters A thru E in Figure 22.

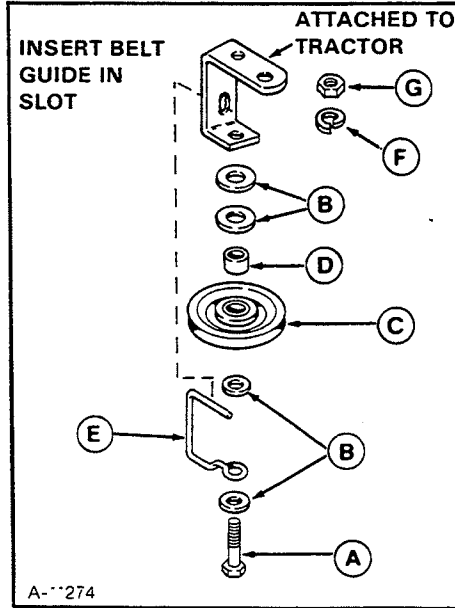

Figure 24.

- A. Capscrew
- B. Washer
- C. Pulley
- D. Spacer
- E. Belt Guide
- F. Lockwasher
- G. Nut

MOWER BELT REPLACEMENT



CAUTION

To avoid damaging belt do not pry belt off pulleys.

1. Remove mower from the tractor.
2. Loosen the belt guide (C, figure 25) on the idler pulley.
3. Remove the belt from the pulleys.
4. Install the new belt on the pulleys as shown in figure 26.
5. Reposition the belt guide on the idler pulley (figure 25). Before tightening the nut (D), position the belt guide so it is 1/4 inch (6 mm) behind the idler arm (B) when viewed from above (figure 25). Hold the belt guide when tightening nut.
6. Reinstall the mower on the tractor (see Mower Installation). Check mower drive belt tension as outlined in the Adjustment section. Run the mower under no load conditions for about 5 minutes and recheck the mower drive belt tension.

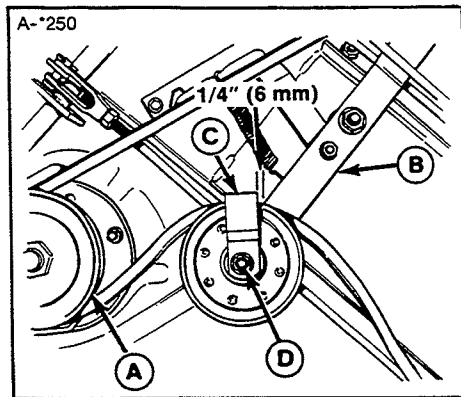

Figure 25. Mower Belt Replacement

- A. Arbor Pulley
- B. Idler Arm
- C. Belt Guide
- D. Nut

NOTE

Each time after changing the mower belt tension, perform the remaining mower adjustments: Right-Arbor Belt Stop, Idler Pulley Belt Guide and PTO Pulley Belt Stops.

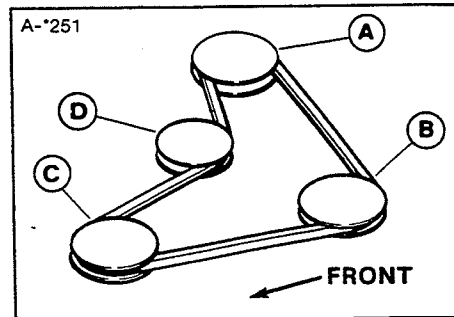

Figure 26. Mower Belt Pattern - 36"

- A. V-Pulley, Right Arbor
- B. V-Pulley, Left Arbor
- C. Engine PTO Pulley
- D. Flat Idler Pulley

Adjustments



WARNING

To avoid serious injury, perform adjustment only with engine stopped, key removed, and tractor on level ground.



WARNING

Disconnect the battery cables, negative cable first before performing adjustments. If this is not done, the electrical circuit can easily be shorted to the frame by a tool, which could cause sparks or electrical shock.

TRACTOR BRAKE ADJUSTMENT

1. Release the parking brake.
2. Put a feeler gauge just behind brake disc (A, figure 27). Clearance between disc and pad should be 0.010 inch (0.254 mm). If not, tighten or loosen the adjustment nut (B) to achieve correct dimension. Some models are equipped with two nuts. If so, loosen the outer nut, adjust the inner nut as necessary, then tighten the outer nut.

3. With the rod guide (A, figure 28) on brake rod as far rearward as slot will allow, the nut (D) should be snug against spring (C) but spring should still be able to rotate. Tighten or loosen nut as necessary to achieve this.

ENGINE PULLEY BELT STOPS

Adjust the two belt stops (A, figure 22) so there is 1/8" between belt stops and belt.

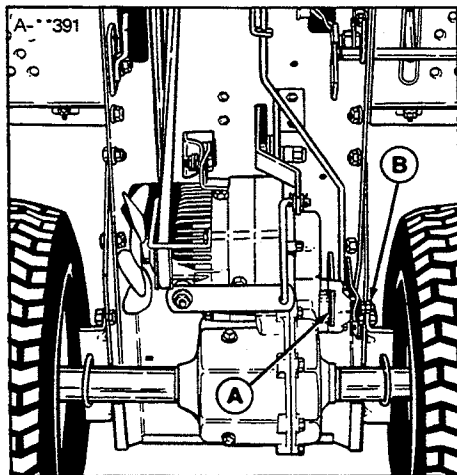

Figure 27. Brake Adjustment

- A. Insert feeler gauge
B. Adjustment Nut

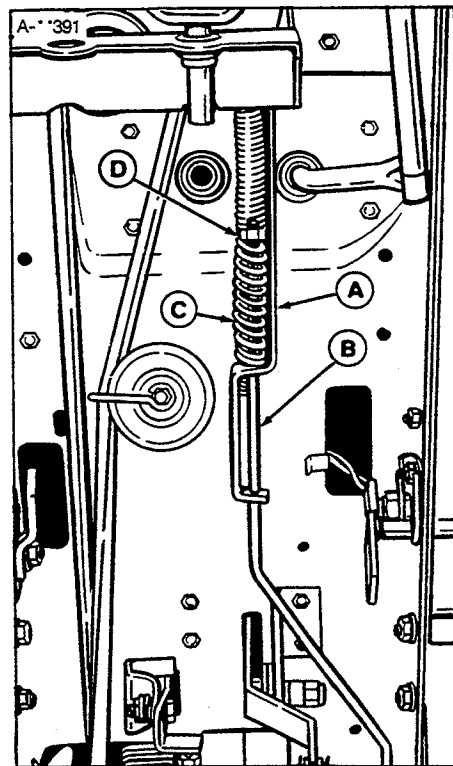

Figure 28. Brake Adjustment

- A. Rod Guide
B. Brake Rod
C. Spring
D. Nut

NEUTRAL ADJUSTMENT

If the tractor creeps forward or back with transmission in neutral notch, adjust as follows.

1. Seat yourself in the operator's seat and start the engine.
2. Move the lever to position where tractor remains stationary. This is neutral position.
3. Stop the engine.
4. Disconnect the battery cables to avoid causing short circuit or sparks with tools.
5. Raise the seatdeck. The control lever quadrant (figure 29) is mounted with slotted holes so it can be adjusted. Loosen the two self-tapping screws and move the quadrant so the lever moves to correct position. Then tighten the two screws.
6. Connect the battery cables.
7. Lower the seat deck. Start the engine to check again. If the tractor still creeps in neutral, repeat the procedure to adjust.

TRANSMISSION CONTROL LEVER

If lever (H, figure 8) operates too hard or loose, it can be adjusted. Loosen or tighten the nut (B, figure 30) to loosen or tighten the lever. Some models are equipped with set-screws (D) which must be loosened to adjust the nut.

TRANSMISSION ENGAGEMENT LEVER

If transmission engagement lever (under seat) does not work properly, check the adjustment as follows.

1. Release the parking brake.
2. Place the transmission control lever in NEUTRAL.
3. Place the transmission engagement lever (B, figure 29) in forward position (disengaged position).
4. Locate the plunger (A, figure 30) on front of the transmission which is operated by the lever. Check the clearance between the plunger and the fitting as shown in the detail in figure 30. it should be 0.060 inch to 0.125 inch.

5. To adjust, loosen the screws which secure the engagement lever support bracket (C, figure 30) and move bracket to achieve the 0.060 to 0.125 inch dimension, then tighten the screws.

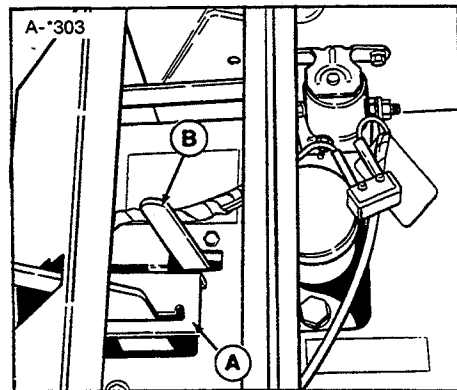

Figure 29. Control Lever Quadrant

A. Quadrant

B. Transmission Engagement Lever

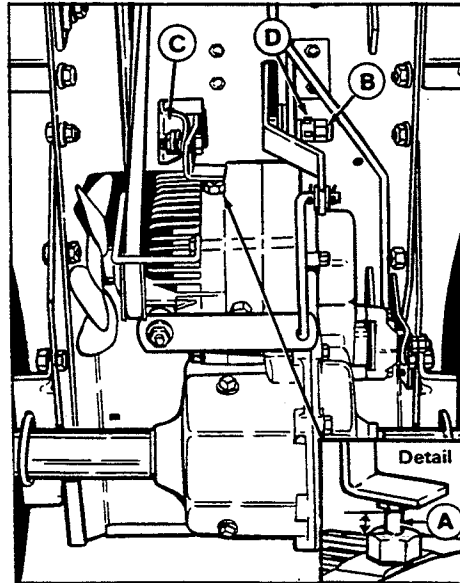

Figure 30. Engagement Lever

- A. Plunger
 B. Nut
 C. Support Bracket
 D. Setscrews

MOWER ADJUSTMENTS

Mower Drive Belt Tension

Using the mower lift lever, lower the mower.
 Using the height control lever, place the

mower in highest cutting position. Place the PTO lever in engaged position, the gap between the rod guide (A, figure 31) and the set collar (B) should measure $3/8$ to $1/2$ inch (10 to 13 mm). If not, disengage the PTO. Loosen the setscrew (C). Move the rod forward to increase the gap or back to decrease the gap then tighten the setscrew. Engage the PTO and recheck the adjustment. Readjust if necessary.

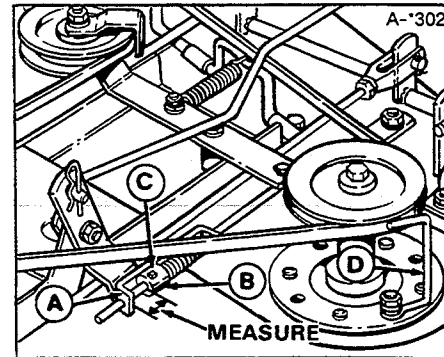

Figure 31. Drive Belt Tension

- A. Rod Guide
 B. Set Collar
 C. Setscrew
 D. Belt Stop

Arbor Belt Stops

The arbor belt stops are item D in figure 31 and item B in figure 32. There should be $1/8$ inch (3 mm) clearance between the belt stops and belt when the PTO lever is engaged. If not, loosen the nut, move the belt stop and retighten the nut.

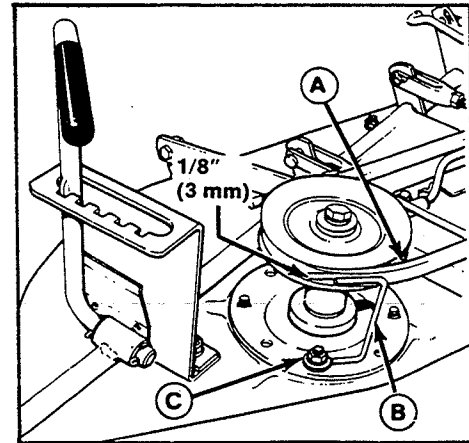

Figure 32. Right Arbor Belt Stop

- A. Belt
 B. Belt Stop
 C. Nut

Idler Pulley Belt Guide

The idler pulley belt guide is correctly adjusted when its edge is 1/4 inch (6 mm) from the rear edge of the idler arm (figure 33). If not, loosen the nut (C) and move the belt guide. Tighten the nut and recheck the measurement.

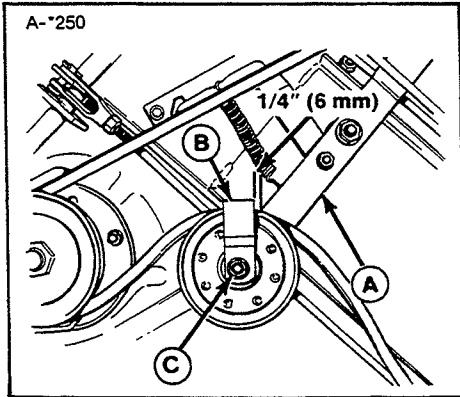

Figure 33. Idler Pulley Belt Guide

- A. PTO Idler Arm
- B. Belt Guide
- C. Nut

PTO Pulley Belt Stops

There are two belt stops at the PTO pulley; one on the left (figure 34) and one on the right (figure 35). With the PTO lever engaged, measure the distance between the belt stop and belt. There should be 1/16 inch (1.5 mm) clearance between each belt stop and the belt. To adjust a belt stop, loosen its mounting capscrew, move the belt stop, and retighten the capscrew. Recheck the measurement.

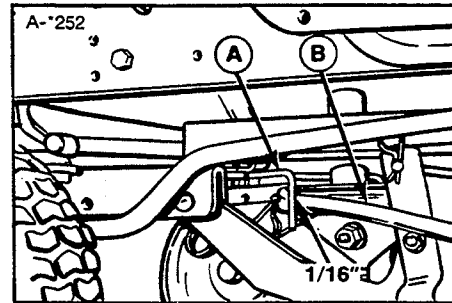

Figure 34. Left PTO Pulley Belt Stop

- A. Belt Stop
- B. Belt

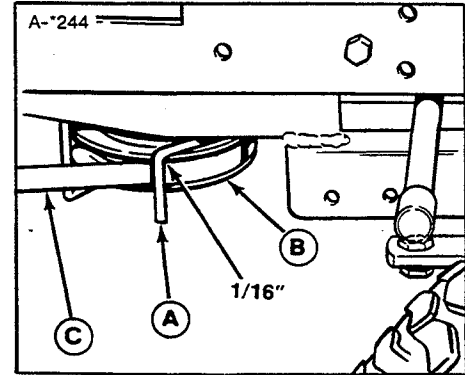

Figure 35. Right PTO Pulley Belt Stop

- A. Belt Stop
- B. PTO Pulley
- C. Belt

Levelling the Mower

If the cut is uneven, the mower may need levelling. Unequal or improper tire pressure may also cause an uneven cut.



WARNING

To prevent accidental starting, remove the ignition key and then remove the spark plug wire and fasten it away from the spark plug.

1. With the mower installed, place the tractor on a smooth level surface, such as a concrete floor. Turn the front wheels straight forward.
2. Check for bent blades, and replace if necessary.
3. Disengage the PTO. Arrange the mower blades so that they are both pointing from side-to-side, perpendicular to the tractor. Engage the PTO.
4. Measure the distance between the outside tips of each blade and the ground. If there is more than 1/8 inch (3 mm) difference between the measurements on each side, proceed to step 5. If there is 1/8 inch (3 mm) or less difference proceed to step 6.
5. Remove the cotter pin (E, figure 36) which secures the mower levelling rod (D). Shorten the rod (D) to raise the left side of the mower or lengthen the rod to lower the left side of the mower. Put the levelling rod back in its hole and recheck the measurements. If the mower is level, install the cotter pin (E).
6. Disengage mower PTO to arrange the blades so they are facing front to back, parallel with the tractor. Engage mower PTO again.
7. Measure the distance to the ground from the front tip of the left blade and the rear tip of the right blade. The measurements should be equal. If they are not, proceed as follows.

NOTE

One full turn of clevis will equal about 1/8 inch.

8. Remove the cotter pins and pins (B) from the hitch clevises (C). Loosen the two nuts (A). Turn each clevis an equal number of turns in the same direction. Shorten the hitch rods to raise the front of the mower or lengthen the hitch rods to lower the front of the mower.
9. Reinstall the pins through the clevises (C) and rear suspension arm (F) and recheck the measurements. When the mower is level, reinstall the cotter pins and tighten nuts (A) against clevises (C).

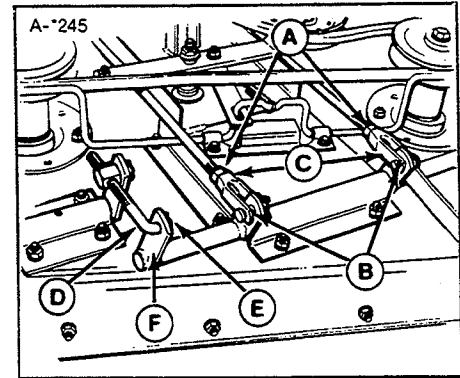

Figure 36. Levelling Mower

- A. Jam Nuts
- B. Pins
- C. Hitch Clevises
- D. Mower Levelling Rod
- E. Cotter Pin
- F. Suspension Arm

SMALL LIFT LEVER

NOTE

Use this procedure if small lift lever (E, figure 8, page 7) is used. If optional large lift lever (B, figure 8) is used, go to next procedure.

1. Place the mower in low cut position. Using the lift lever, raise the mower.
2. Measure the distance between top of upstop bracket and bottom of footrest (figure 37). The measurement should be 2-13/16 inch.
3. To adjust, disconnect clevis (E) from chain. Loosen nut (A) and turn clevis to raise or lower mower. Reconnect chain to check measurement. When correct, tighten nut against clevis.

LARGE LIFT LEVER

NOTE

Use this procedure if optional large lift lever (B, figure 8, page 7) is used. If small lift lever (E, figure 8) is used, see previous procedure.

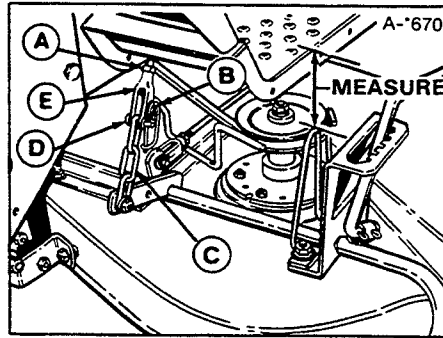

- A. Nut
- B. Clip
- C. Chain
- D. Pin
- E. Clevis

Figure 37. Lift Assembly - Small Lift Lever

1. Place the mower in low cut position. Using the lift lever, raise the mower.
2. Measure the distance from bottom edge of lever bracket to mower deck (figure 38).
3. The measurement should be 5 inches.
4. To adjust, disconnect trunnion (C, figure 39) from lift chain. Loosen the nut, and turn trunnion to raise or lower mower. Tighten nut when measurement is correct.

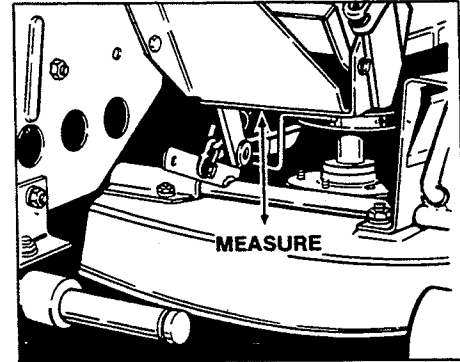
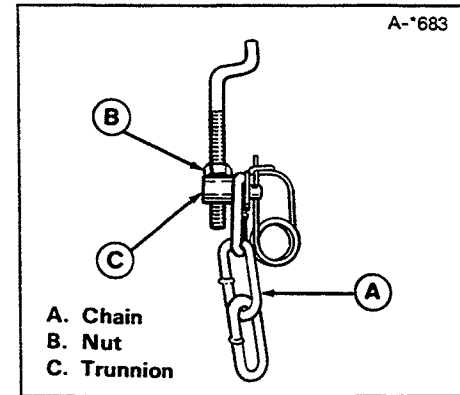

Figure 38. Measurement - Large Lift Lever



- A. Chain
- B. Nut
- C. Trunnion

Figure 39. Lift Assembly - Large Lift Lever

Specifications

BASIC ENGINE

Make: Briggs & Stratton - 4 cycle, air cooled

Model & Type: See engine I.D. plate

Horsepower: 11 HP @ 3600 rpm (Eng. Mfg's. Rating)

12 HP @ 3600 rpm (Eng. Mfg's. Rating)

Cylinder: 1 horizontal

Bore & Stroke 11 HP: 3.44 x 2.62 inches (87 x 67 mm)

12 HP: 3.44 x 3.06 inches (87 x 78 mm)

Displacement: 11 HP: 24.36 cu. in. (399 cc)

12 HP: 28.4 cu. in. (465 cc)

Crankshaft: Vertical, syncrobalanced

Battery: 12 volt, 39 amp. hour

Governor: Mechanical, full throttle - no load setting

@ 3400 \pm 100 rpm; idle speed @ 1750 \pm 200 rpm

Crankcase Capacity: See engine manual

Ignition: Electronic

Charging: Unregulated 3-amp DC charging circuit

Air Cleaner: Oil foam with reuseable polyurethane element

Fuel Tank: 2.2 gallons (8.3 liters) of "regular" grade leaded or nonleaded gasoline.

Starter: 12 volt electric gear drive

TRANSMISSION

Type: Belt drive to hydrostatic transmission

Differential: Gear reduction unit with bevel gears.

Ground speeds @ 3400 rpm:

Forward - 0 to 5.25 mph

Reverse - 0 to 3.00 mph

DIMENSIONS & WEIGHT

Height (at steering wheel): 39 in. (99 cm)

Width: 33.75 in. (88 cm)

Length: 65.25 in. (166 cm)

Clearance - Front Axle: 9 in. (228 mm)

Clearance - Transmission: 4.75 in. (120 mm)

Wheel Base: 45.5 in. (1156 mm)

Turning Radius: 24 in. (610 mm) to inside of rear wheel

Front Tires: 15 x 6.00 x 6 Pneumatic

Rear Tires: 18 x 8.50 x 8 Pneumatic

Weight: 11 HP w/36" Mower: 436 lbs. (198 kg)

12 HP w/36" Mower: 433 lbs. (196 kg)

SPECIFICATIONS SUBJECT TO CHANGE WITHOUT NOTICE.

Additional Technical Literature Available



Operators Manuals

Additional copies of this manual are available, (and as part of our product support commitment, we maintain a stock of printed operators manuals going back over 25 years!)

Parts Manuals

Fully illustrated parts manuals are also available — these manuals show all of the product's components in exploded views ("3D" illustrations which show the relationship of the parts and how they go together), as well as giving the replacement part numbers and quantities used. Important assembly notes and special torque values are included in these manuals.

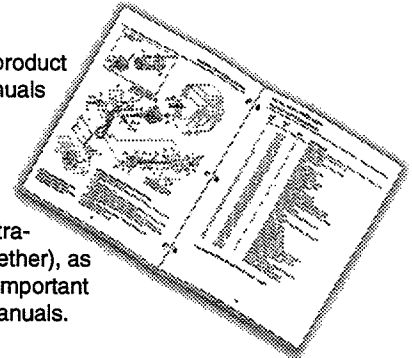

Repair & Service Manuals

In addition, for many models, we have in-depth repair & Service Manuals available, which take you step-by-step through maintenance, tear-down, component replacement and re-assembly procedures.

For the available manuals applicable for your model, contact the Customer Publications Department at 414-284-8519. Have the information listed in the box at the right available when phoning in your request.



| | |
|------------------------------|-------|
| Model: | _____ |
| Mfg. No.: | _____ |
| Your Name: | _____ |
| Address: | _____ |
| City, State, Zip: | _____ |
| Visa/Mastercard No.: | _____ |
| Card Expiration Date: | _____ |



Simplicity

MANUFACTURING, INC.

500 N Spring Street / PO Box 997
Port Washington, WI 53074-0997 USA

© Copyright 1986 Simplicity Manufacturing, Inc.
All Rights Reserved. Printed In USA.