

Simplicity[®]

VACUUM COLLECTOR

Mfr's.No. 343

for

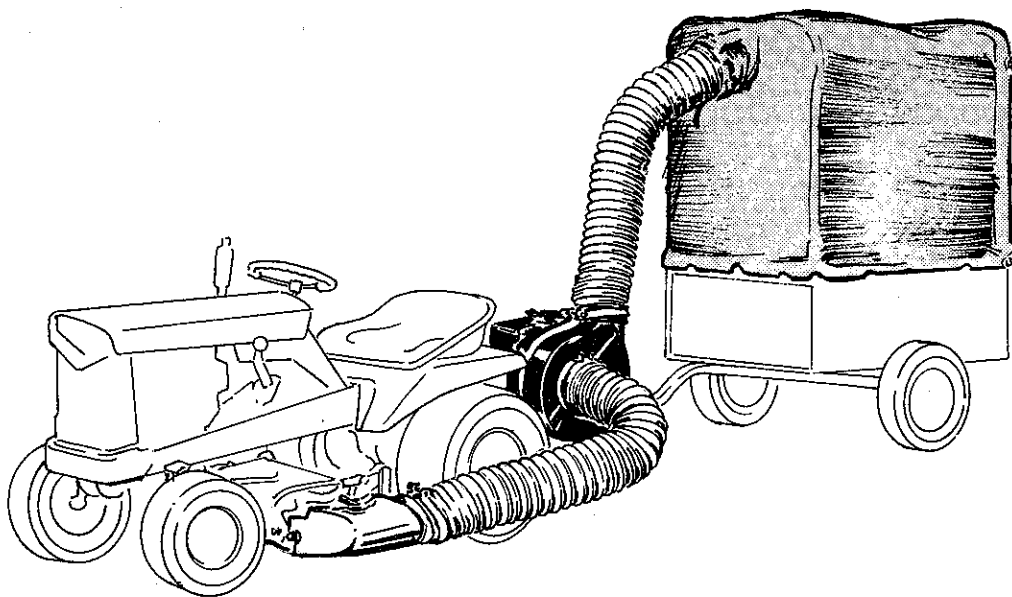

**BROADMOOR
RIDING TRACTOR**

1234567890

PRINTED IN U.S.A.

SIMPLICITY MANUFACTURING COMPANY / PORT WASHINGTON, WIS.

1268

ASSEMBLY

The cart enclosure for the vacuum collector consists of a metal framework and a canvas cover, all of which fits on the dump cart body. Here follows step by step illustrations showing the sequence of assembly for this unit.

A. The enclosure should be constructed on the cart body, starting with the lower channel members shown in Figure 1. The front support assembly is then added as shown in Figure 2. (Refer to the exploded view and parts list on Pages 8 & 9 for descriptions of the hardware used in this construction).

B. Thread the canvas enclosure over the rear support assembly as shown in Figure 3, and place the other end of the canvas over the front support assembly as illustrated.

C. Now complete the frame construction by attaching the braces to each of the four corners as shown, using the appropriate hardware as called out on the parts list.

D. Figure 4 shows the insertion of the side reinforcing members into the slots at the sides of the canvas enclosure. Secure these in place on both sides as shown in Figure 5, with the capscrews and attaching hardware provided.

E. Insert the front reinforcing member into the slot at the front edge of the enclosure, and attach the catch bracket in the center as shown in Figure 6. The catch is secured with a lock nut which should be tightened just enough to hold securely but still allow pivoting.

F. Attach the upper hanger brackets to the rear support frame as shown in Figure 7. The lower latches on the rear frame support are then attached with the appropriate hardware as called out in the exploded view and parts list. Check to see that the latches are secure, but still free to pivot.

G. The rear door is constructed by inserting the rear frame into the slots in the rear canvas. The bottom reinforcing rod is then inserted in the bottom canvas slot, and is secured in position by means of the nuts and washers provided. See Figure 8. The reinforcing strap is positioned over the lower outside portion of the door as shown in Figure 9, and is secured in place with the capscrews, spacers and attaching hardware called out on the exploded view and parts list. Attach the upper latching stud assemblies to the holes provided in the upper part of the door frame as shown in Figure 8, then position the top edge of the canvas over the top of the door frame as shown.

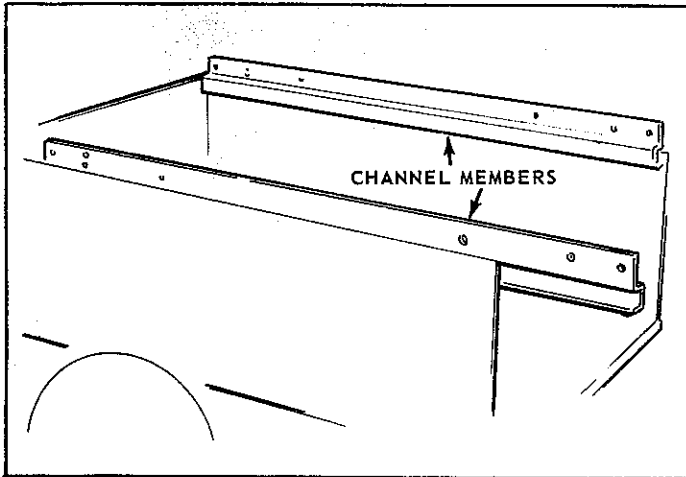

FIGURE 1

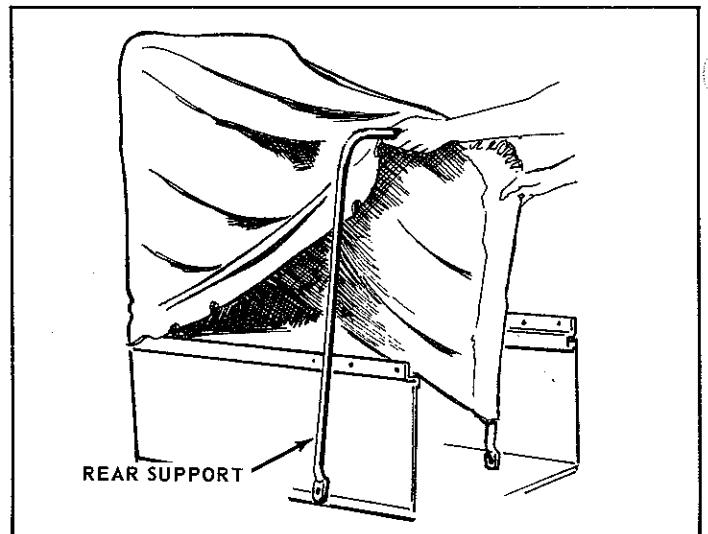

FIGURE 3

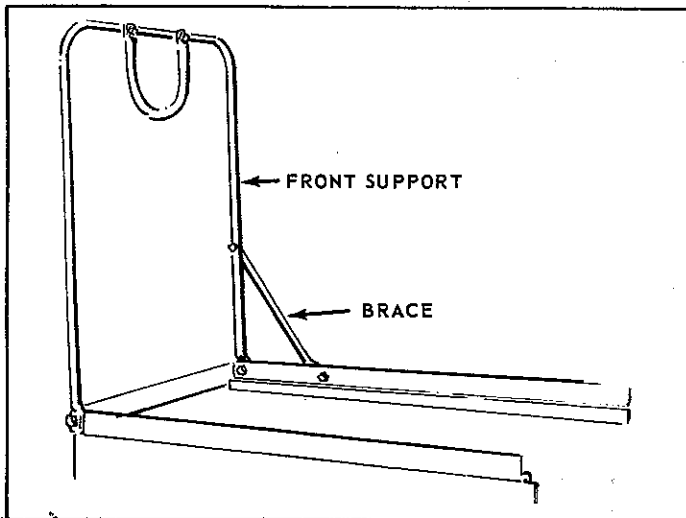

FIGURE 2

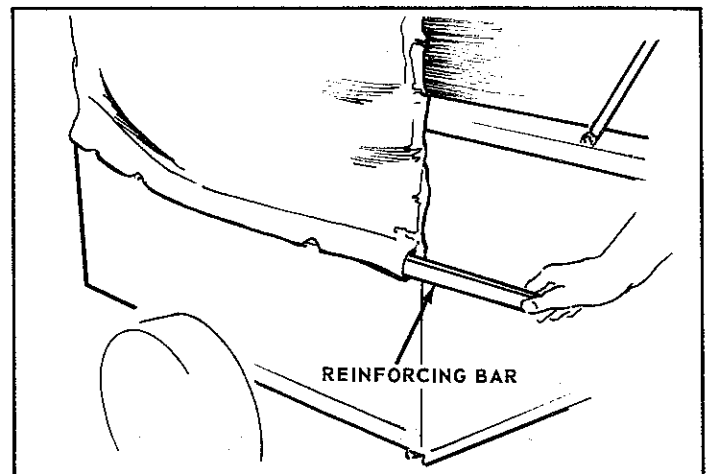

FIGURE 4

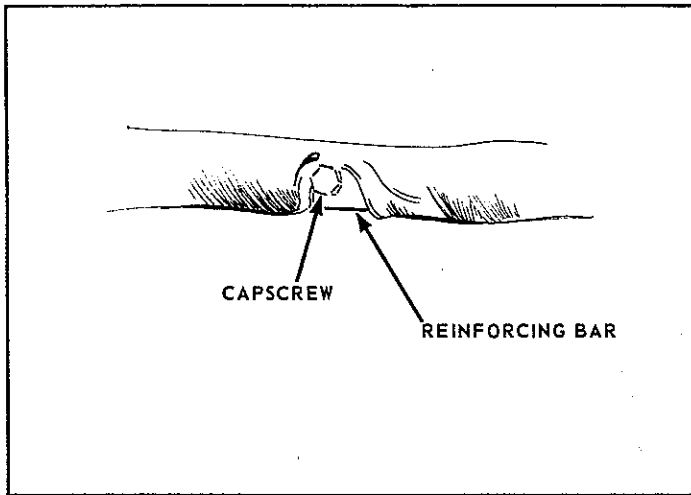

FIGURE 5

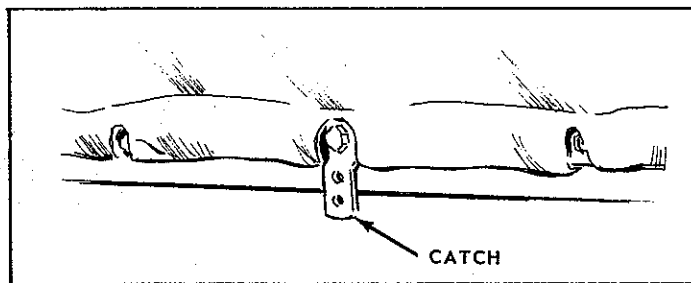

FIGURE 6

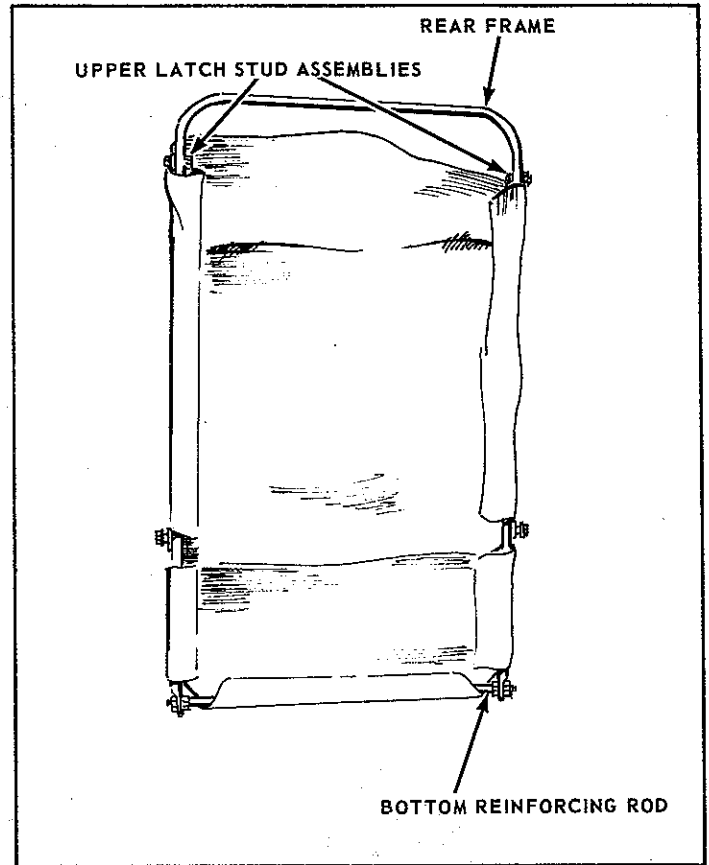

FIGURE 8

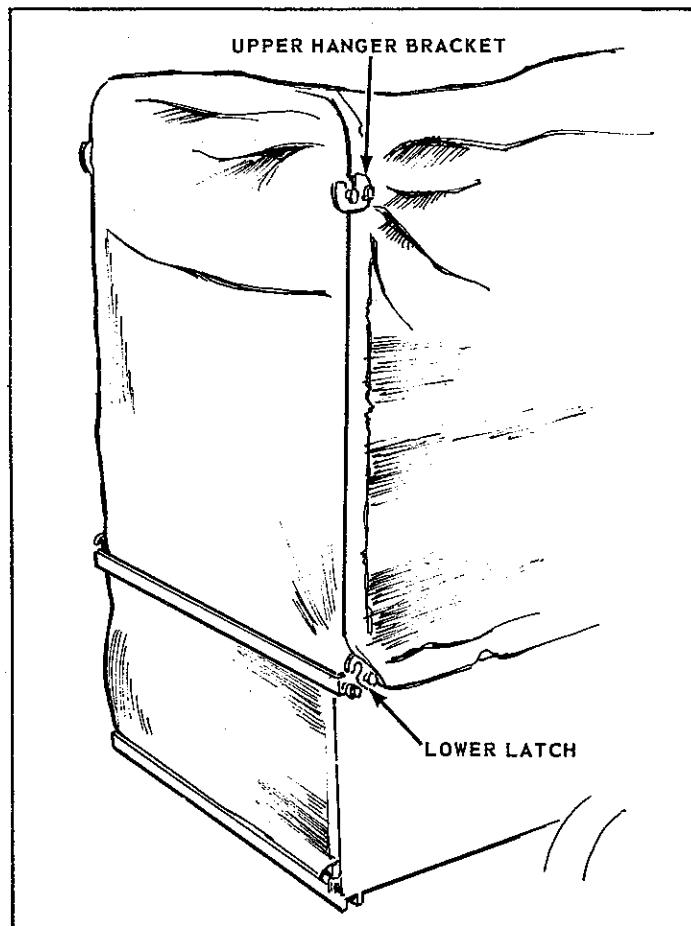

FIGURE 7

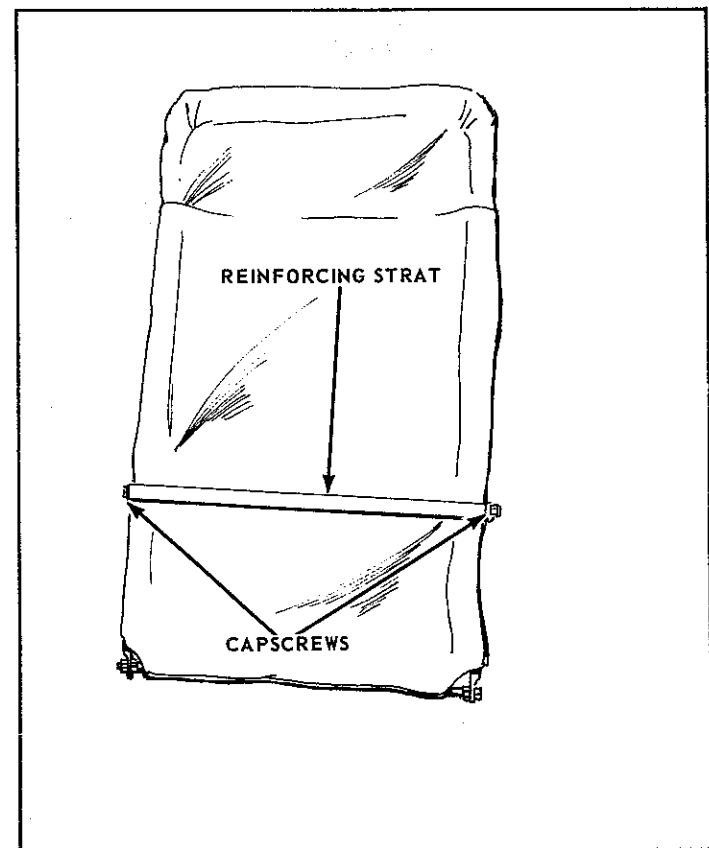
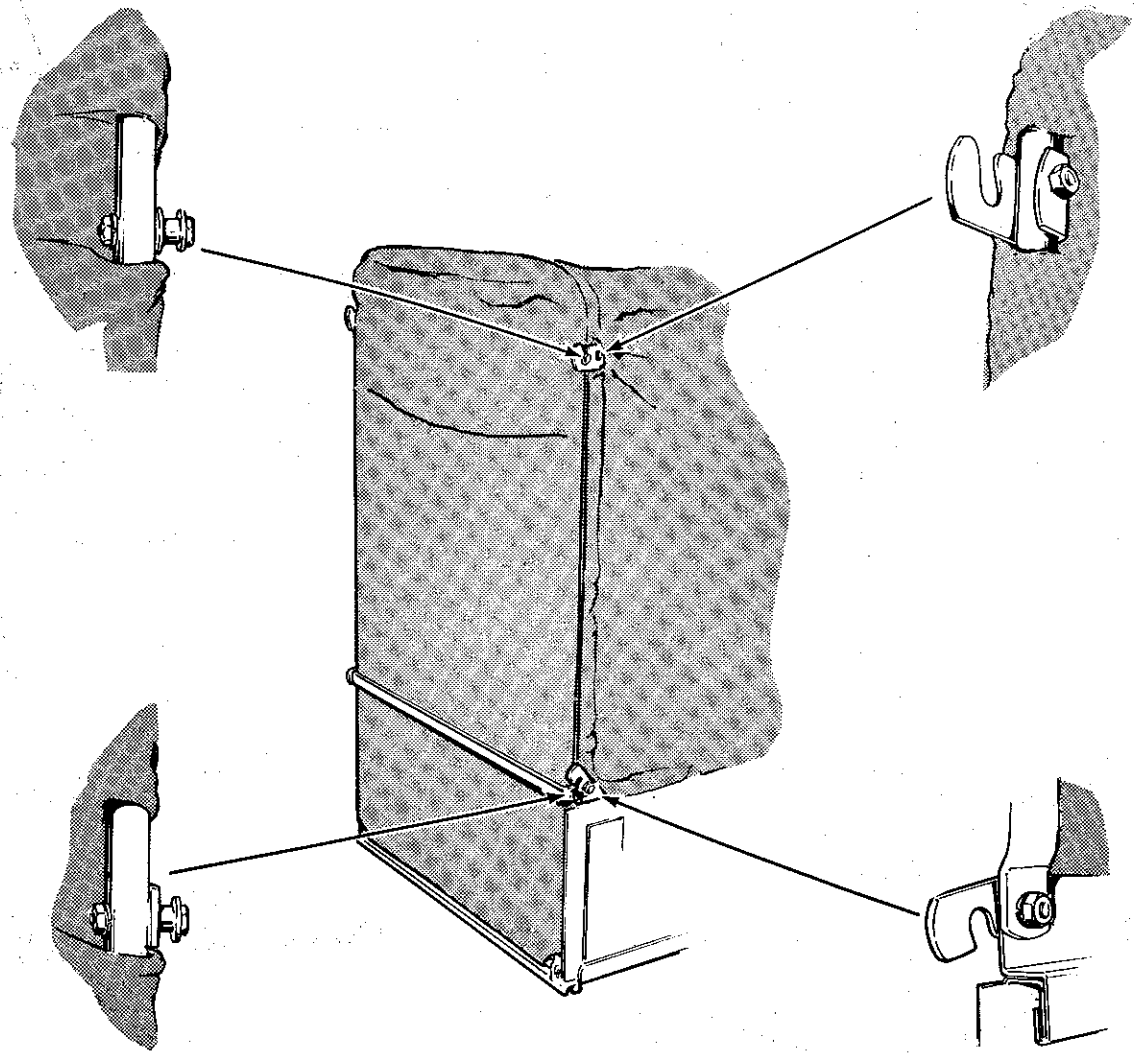
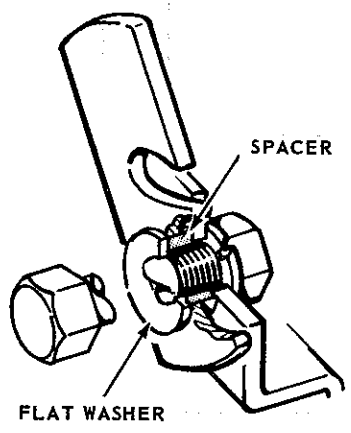
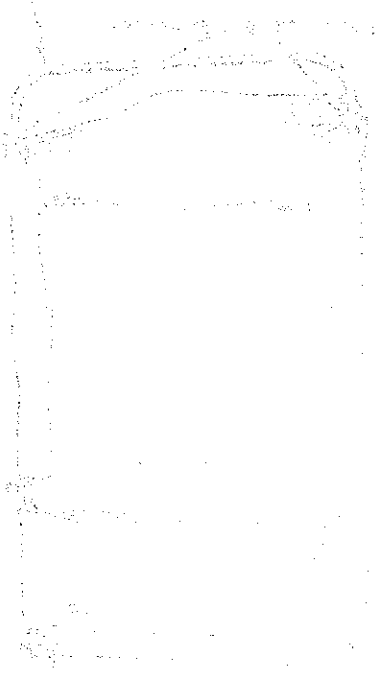

FIGURE 9



Secure the large hose to the Hose Flange with the clamp and screw provided; then place in position on the Blower Housing. Place the other end of the large hose securely over the spout extension on the exhaust cover. (Figure 10 & 12).

The smaller sized hose is then secured to the outlet opening on top of the blower, and the other end of the hose is positioned through the canvas sleeve at the upper front of the cart enclosure, and secured in place by means of the strap and buckle. (Figure 10 & 11)

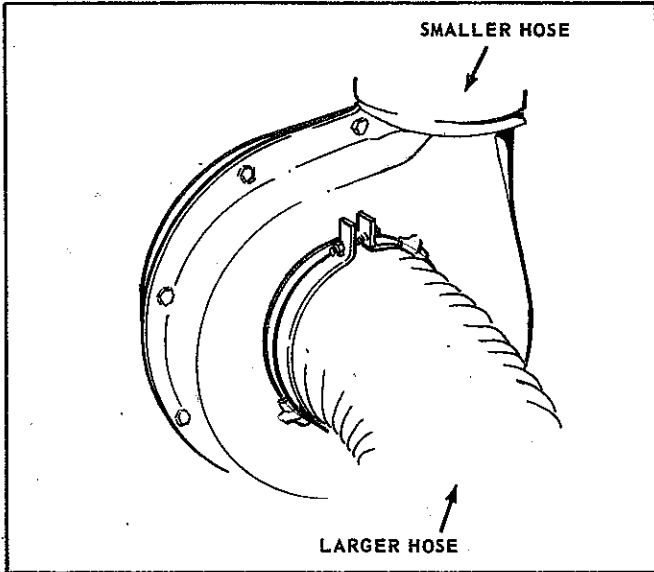

FIGURE 10

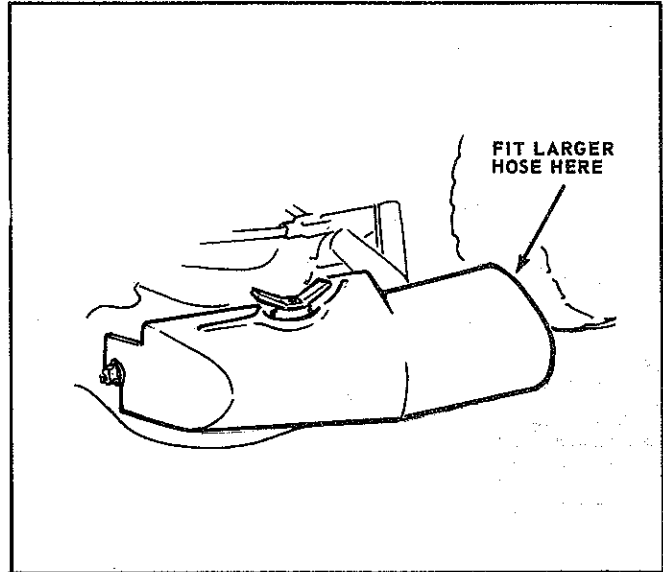

FIGURE 12

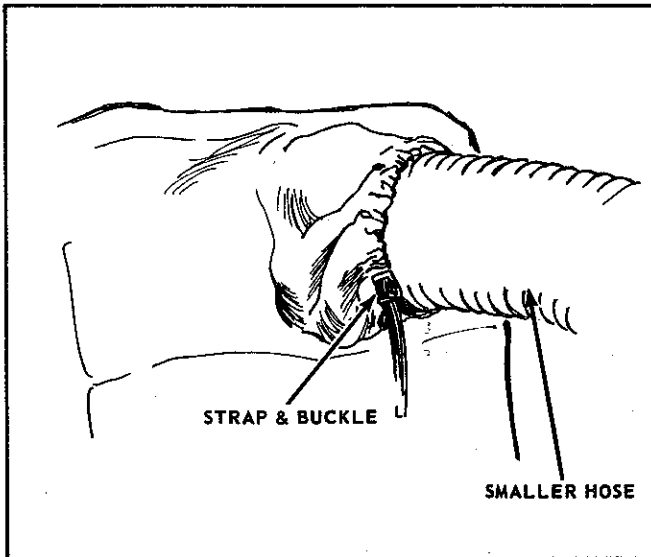

FIGURE 11

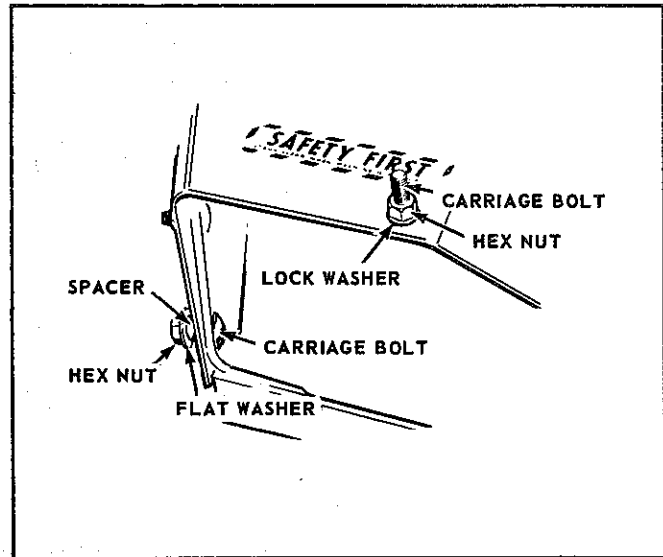

FIGURE 13

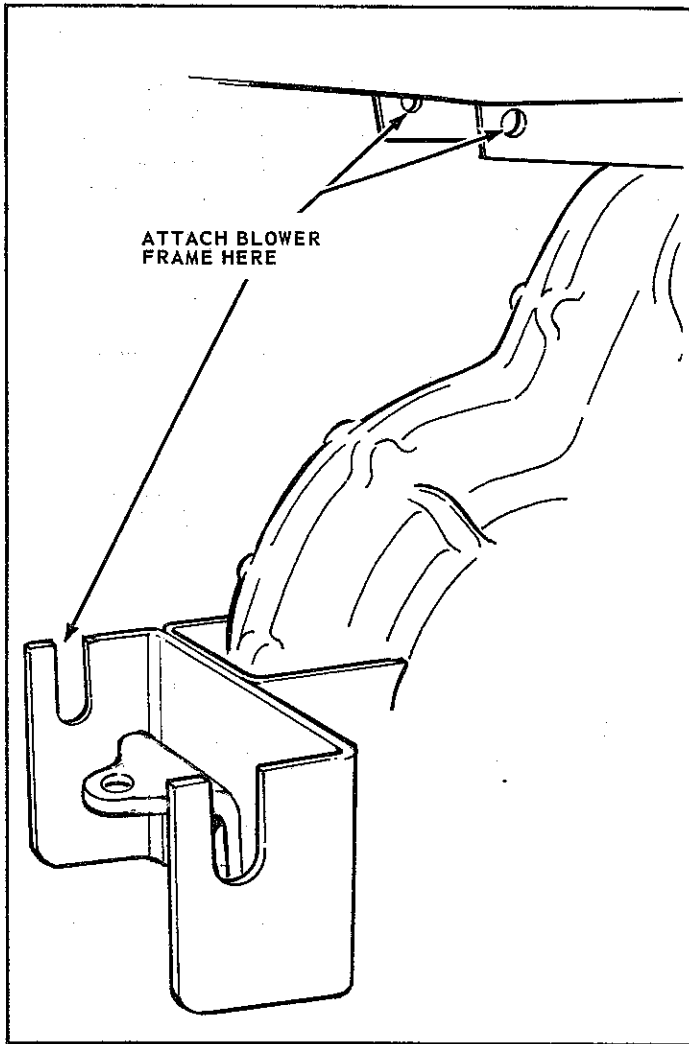

FIGURE 14

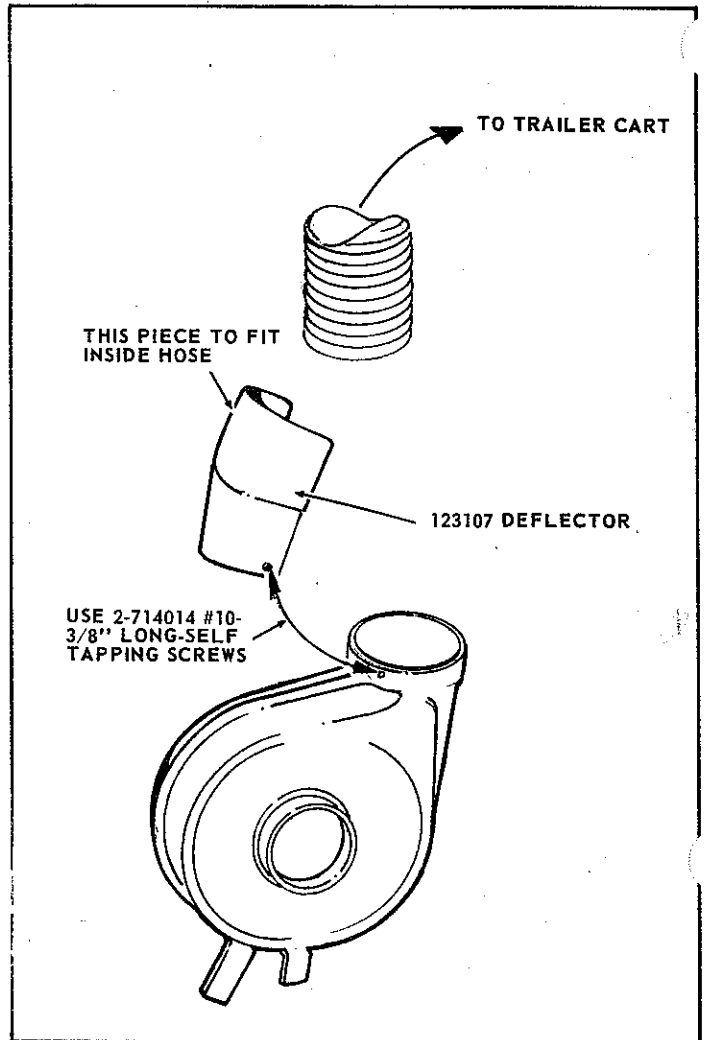

FIGURE 15

PACKING

For use of shipping the Vacuum Collector is packaged in two cartons. The long carton contains the two hoses. The large carton contains the blower unit with the Engine hitch, metal frame and a canvas cover for the dump cart .

ASSEMBLY

Replace Draw Bar Hitch Clip from Draw Bar Bracket with the hitch provided. See Figure 14. (Use same hardware). Attach deflector to top of Blower Housing by two screws provided. See Figure

ENGINE

Service Engine according to manufactures instructions before operating.

COLLECTOR & BLOWER HOUSING

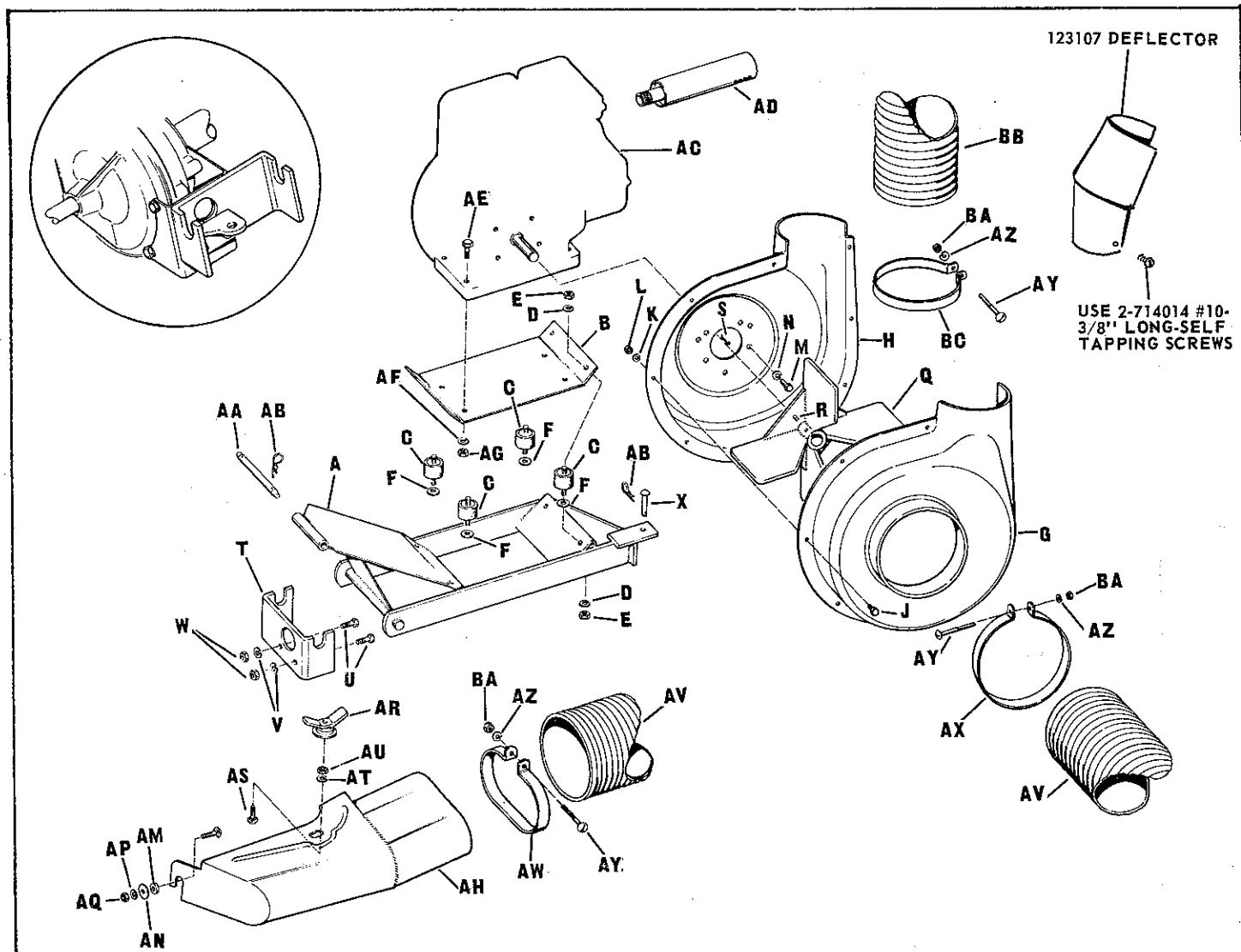

123107 DEFLECTOR

USE 2-714014 #10-3/8" LONG-SELF TAPPING SCREWS

Ref. Let.	Part No.	Description
A	123088	Frame Assembly
B	123095	Engine Plate
C	157094	Connector, Cushion
D	720001	Lock Washer 5/16"
E	717001	Full Hex Nut 5/16"-18NC
F	719002	Plain Washer 5/16"
G	123009	Housing, Inlet Half
H	123013	Housing Half-Blower, R.H.
J	705002	Hex Cap Screw 1/4"-20NC x 1/2"
K	720003	Lock Washer 1/4"
L	717005	Full Hex Nut 1/4"-20NC
M	706016	Hex Cap Screw 5/16"-24 NF x 5/8"
N	720001	Lock Washer 5/16"
Q	123015	Fan Assembly
R	713006	Set Screw 5/16"-18 x 1/2"
S	8221042	Key
T	123096	Hitch
U	705009	Hex Cap Screw 3/8"-16 x 1-1/2"
V	720002	Lock Washer 3/8"
W	717003	Full Hex Nut 3/8"-16NC
X	118053	Pin
AA	156268	Counterweight Pin
AB	8161045	Clip Spring

Ref. Let.	Part No.	Description
AC	123097	Engine
AD	123104	Muffler
AE	705018	Hex Cap Screw 5/16"-18 x 1-1/2"
AF	720001	Lock Washer 5/16"
AG	717001	Full Hex Nut 5/16"-18NC
AH	123098	Housing Assembly
AL	703002	Carriage Bolt 3/8"-16 x 1-1/4"
AM	153081	Spacer
AN	157169	Washer
AP	720002	Lock Washer 3/8"
AQ	717003	Full Hex Nut 3/8"-16 NC
AR	123103	Nut Assembly
AS	703010	Carriage Bolt 5/16"-18NC x 1"
AT	720001	Lock Washer 5/16"
AU	717001	Full Hex Nut 5/16"-18NC
AV	123064	Intake Hose 7" Diameter
AW	123105	Hose Clamp
AX	123065	Hose Clamp
AY	715069	Hd. Rd. Mach. Screw 1/4"-20 x 3"
AZ	720003	Lock Washer 1/4"
BA	717005	Full Hex Nut 1/4"-20NC
BB	123066	Exhaust Hose 6" Diameter
BC	123067	Hose Clamp

TRAILER FRAME & COVER

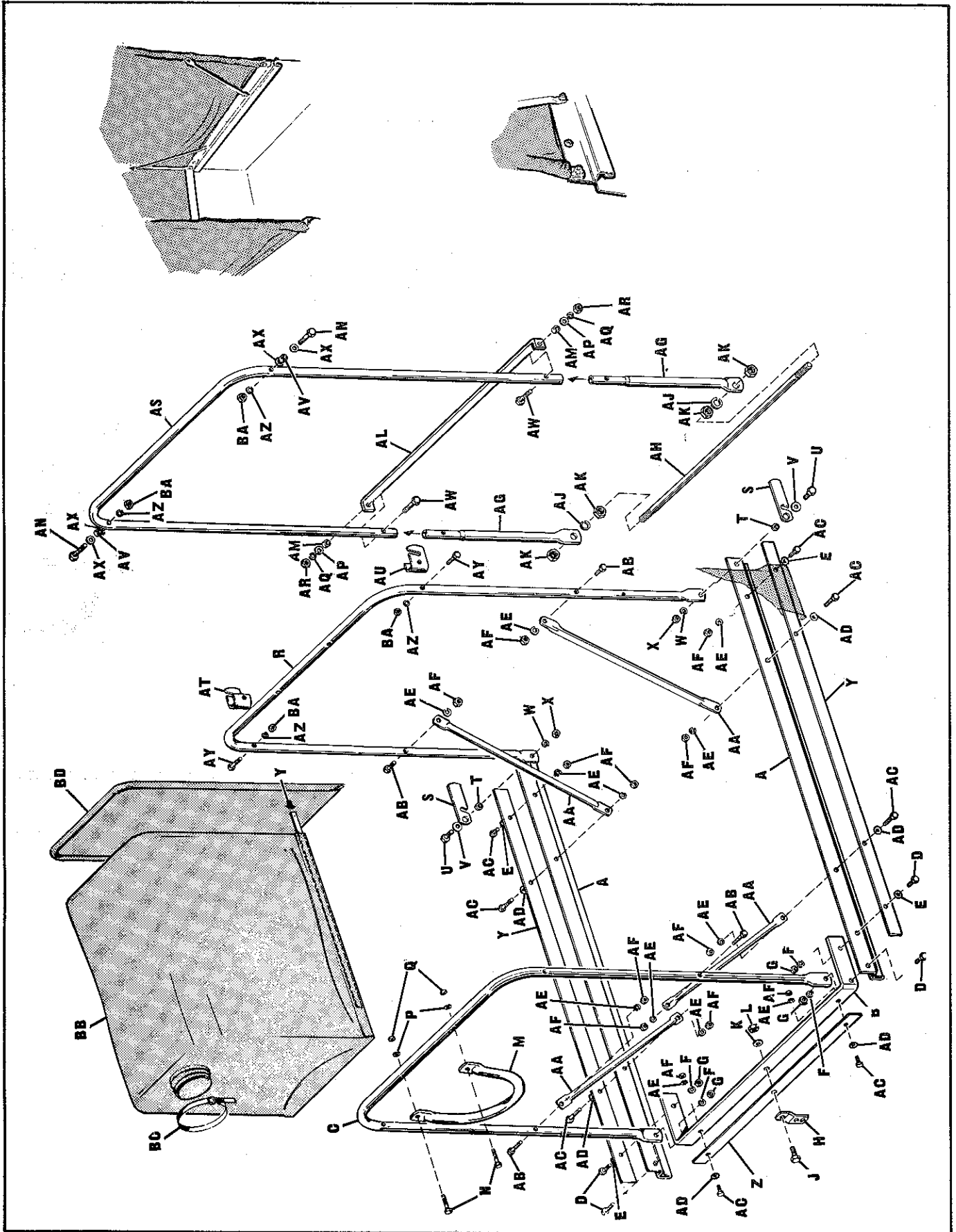

TRAILER FRAME & COVER

PARTS LIST

Ref. No.	Part No.	Description
A	123036	"Z" Bar, Side
B	123037	Front Bar
C	123038	Front and Rear Upright
D	705007	Hex Capscrew, 5/16"-18 x 1" lg.
E	719002	Plain Washer, 5/16"
F	720001	Lock Washer, 5/16"
G	717001	Hex Nut, Full, 5/16"-18
H	112060	Bracket
J	705005	Hex Capscrew, 3/8"-16 x 1" lg.
K	719001	Plain Washer, 3/8"
L	717510	Hex Lock Nut, Full, 3/8"-16
M	123039	Hose Support
N	705008	Hex Capscrew, 1/4"-20 x 1-1/4 lg.
P	720003	Lock Washer, 1/4"
Q	717005	Hex Nut, Full, 1/4"-20
R	123038	Front and Rear Upright
S	123040	Rear Door Latch
T	156150	Spacer
U	705001	Hex Capscrew, 5/16"-18 x 7/8" lg
V	719002	Plain Washer, 5/16"
W	720001	Lock Washer, 5/16"
X	717001	Hex Nut, Full, 5/16"-18
Y	123052	Hold Down Strip, Side
Z	123053	Hold Down Strip, Front
AA	123041	Cross Brace Tube
AB	705008	Hex Capscrew, 1/4"-20 x 1-1/4" lg.

Ref. No.	Part No.	Description
AC	705030	Hex Capscrew, 1/4"-20 x 3/4" lg.
AD	719006	Plain Washer, 1/4"
AE	720003	Lock Washer, 1/4"
AF	717005	Hex Nut, Full, 1/4"-20
AG	123042	Tube, Rear Door
AH	123043	Rod, Rear Door
AJ	720004	Lock Washer, 1/2"
AK	717006	Hex Nut, Full, 1/2"-13
AL	123044	Bar, Rear Door
AM	123045	Spacer
AN	705025	Hex Capscrew, 1/4"-20 x 1-3/4" lg.
AP	719006	Plain Washer, 1/4"
AQ	720003	Lock Washer, 1/4"
AR	717005	Hex Nut, Full, 1/4"-20
AS	123046	Top Rear Door
AT	123047	Catch, Door, R. H.
AU	123048	Catch, Door, L. H.
AV	123045	Spacer
AW	705053	Hex Capscrew, 1/4"-20 x 1-3/4" lg.
AX	719006	Plain Washer, 1/4"
AY	705008	Hex Capscrew, 1/4"-20 x 1-1/4" lg.
AZ	720003	Lock Washer, 1/4"
BA	717005	Hex Nut, Full, 1/4"-20
BB	123049	Cart Hood
BC	123050	Hose Strap
BD	123051	Door Cover

Remember...



FOR YOUR SAFETY

1. ALWAYS STOP ENGINE BEFORE LEAVING MACHINE
2. ALWAYS STOP ENGINE BEFORE SERVICING OR ADJUSTING MACHINE OR EQUIPMENT
3. ALWAYS KEEP HANDS, FEET AND CLOTHING AWAY FROM POWER-DRIVEN PARTS

