

Simplicity

**INSTALLATION INSTRUCTIONS
&
PARTS LIST**

ELECTRIC STARTER

**Mfr's. No.
304**

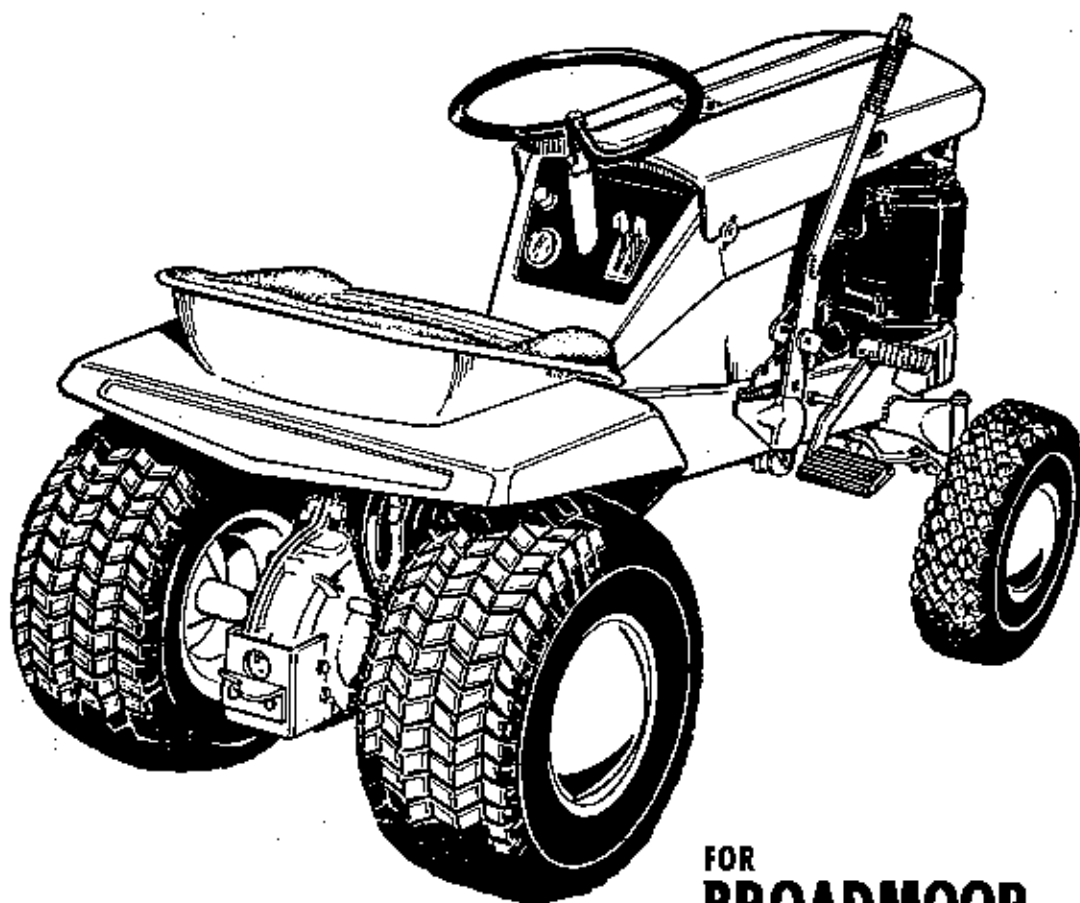

**FOR
BROADMOOR
RIDING TRACTOR**

234567890

SIMPLICITY MANUFACTURING COMPANY, INC.

1614

Before beginning to install the Starter-Generator, carefully read the following instructions to acquaint yourself with the parts and the assembly sequence required.

1. Remove the hood from the tractor.
2. Remove the four long hex nuts that attach the rewind starter to the engine shroud. Refer to Fig. 1. Remove the rewind starter assembly from the engine shroud.

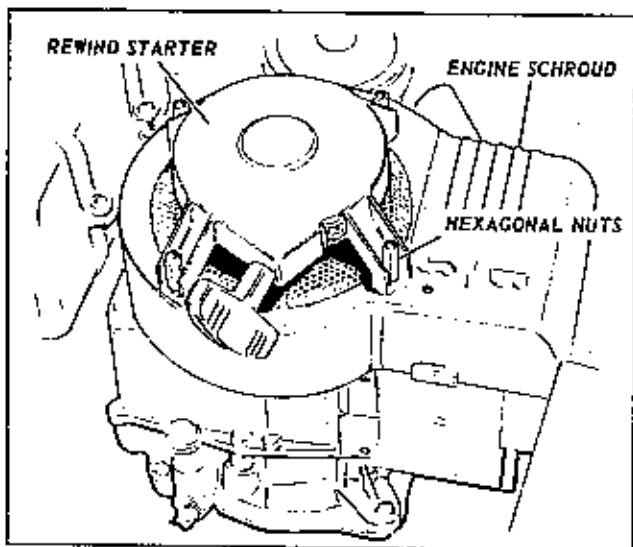

Figure 1

3. Remove the starter ratchet and screen assembly from the end of the engine crankshaft by gently rapping a screw driver against the hex screws #1, Fig. 2. This screen and ratchet assembly is removed in a counter-clockwise direction. Take out the four starter mounting studs #2, Fig. 2, by removing the nuts from the studs. Thread the flywheel nut "CC" (refer to the exploded-view on page 6) over the end of the crankshaft in place of the ratchet assembly.

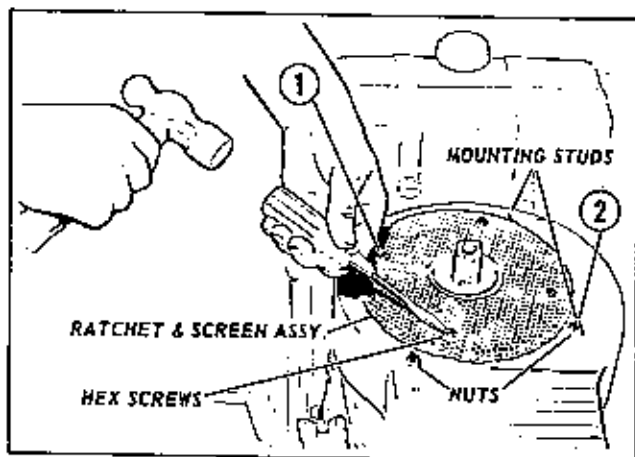

Figure 2

4. Bolt the large flywheel pulley #1, Fig. 4, to the hub of the flywheel, using two 5/16"-18 x 3/4" long hex cap screws #2, Fig. 4, and 5/16" lockwashers. Remove the hex cap screw #3, Fig. 4, from the front support bracket #4, Fig. 4. Install the generator support and belt tension bracket #5, Fig. 4, as shown, with the plain round hole in place behind the front support bracket #4, Fig. 4, and loosely secure with

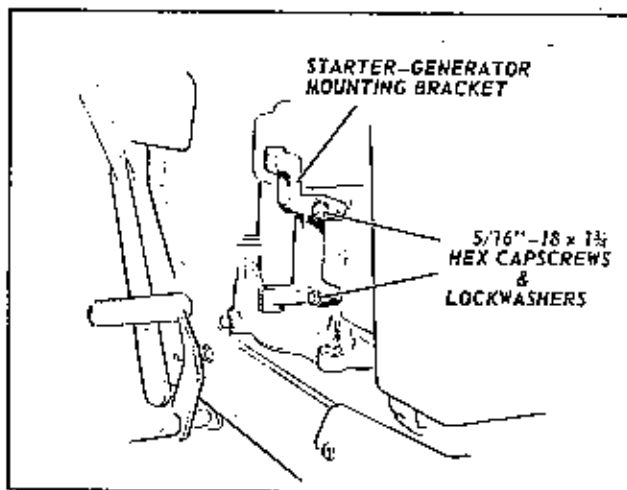

Figure 3

the previously removed cap screw. Attach the starter-generator mounting bracket as shown in Fig. 3, by means of two 5/16"-18 x 1-3/4" long hex cap screws and 5/16" lockwashers. Tighten securely and mount the starter-generator to the mounting bracket with two 5/16"-18 x 3/4" long hex cap screws and 5/16" lockwashers and 5/16"-18 hex nuts. Attach the slotted end of the generator support and belt tension bracket to the starter generator at point #6, Fig. 4, with one 5/16"-18 x 3/4" long hex cap screw, 5/16" plain washer, and 5/16" lockwasher. Leave this cap screw only finger-tight to allow for later belt tension adjustment.

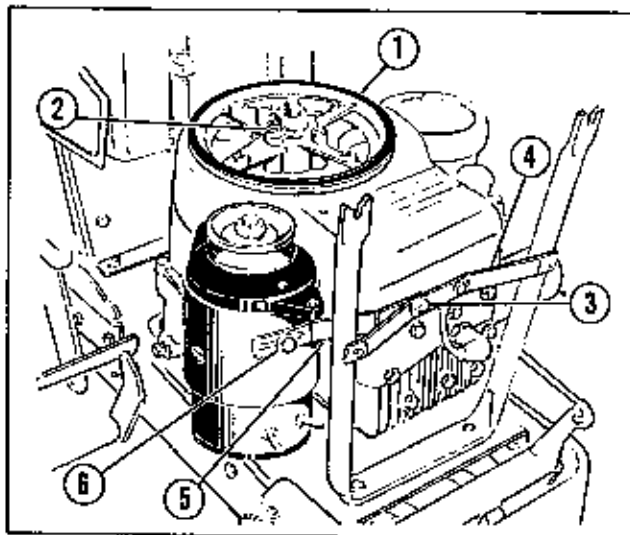

Figure 4

5. Attach the voltage regulator support bracket to the engine shroud through the slotted hole in the bracket, with one 1/4"-20 x 5/8" long hex cap screw, 1/4" plain washer, and 1/4" lockwasher as shown at #1, Fig. 5. Attach the other end of the bracket to the starter-generator by means of the upper starter generator mounting bolt. See #2, Fig. 5. Place the screen & pulley assembly, #3, Fig. 5, over the flywheel pulley with the mounting holes aligned and secure with two 5/16"-18 x 3/4" long hex cap screws, #4, Fig. 5, and 5/16" lockwashers. Tighten securely. Install the starter generator drive belt #5, Fig. 5, over the generator pulley and over the flywheel pulley. Tighten the starter-generator support bracket #3, Fig. 4, and pull the starter-generator out to apply tension on the drive belt. Tighten screw #6, Fig. 4, to hold proper belt tension.

4101

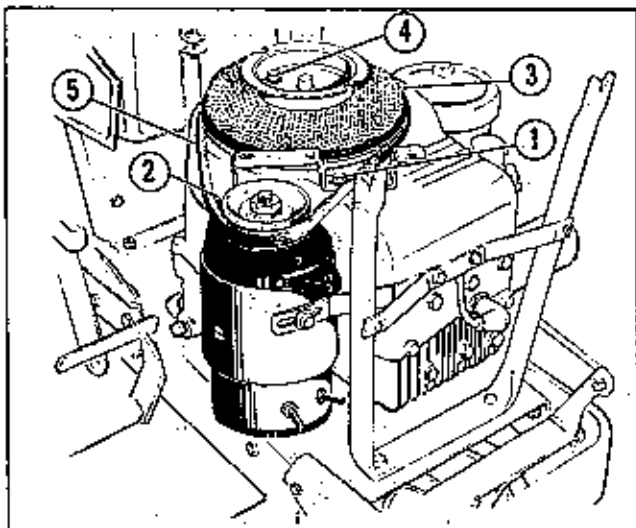

Figure 5

6. Place the pulley guard over the mounting bracket as shown in #1, Fig. 6, and secure in place with two 1/4"-20 x 5/8" long hex capscrews and 5/16" lockwashers at #2, Fig. 6. Install the voltage regulator #3, Fig. 6, over the remaining bracket holes as shown with three terminals facing forward. Before putting the voltage regulator in place, attach one of the equal length small diameter wires to the terminal located on the underside of the voltage regulator. Secure the regulator to the bracket with two 1/4"-20 x 5/8" long hex capscrews and 1/4" lockwashers.

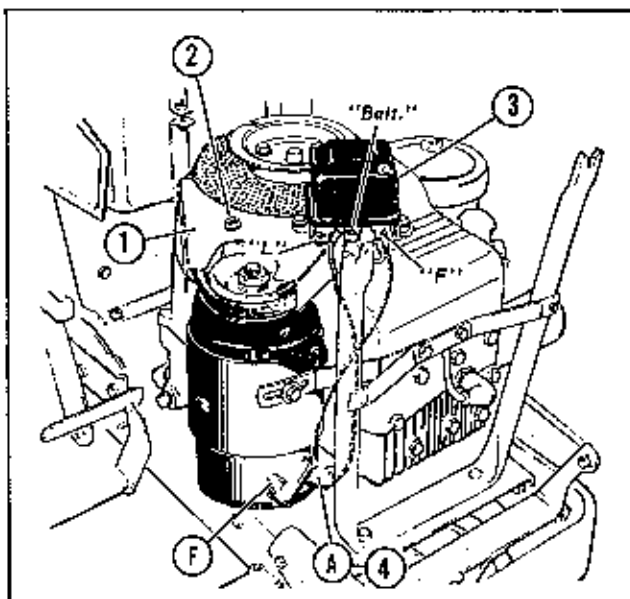

Figure 6

7. Remove the large and small button plugs from the left side of the dash panel. Remove from rear of panel to prevent injury to panel finish. Refer to Fig. 7.

Install the ammeter on the front face of the dash panel through the large hole and fasten from the rear side with mounting bracket "BU" shown on the exploded-view on Page 6. Secure mounting bracket with two 3/8"-16 hex nuts and lockwashers. Install the starter switch from the rear of the panel. Secure the flange of the starter switch in place over two studs welded to the back of panel, using two hex nuts and lockwashers.

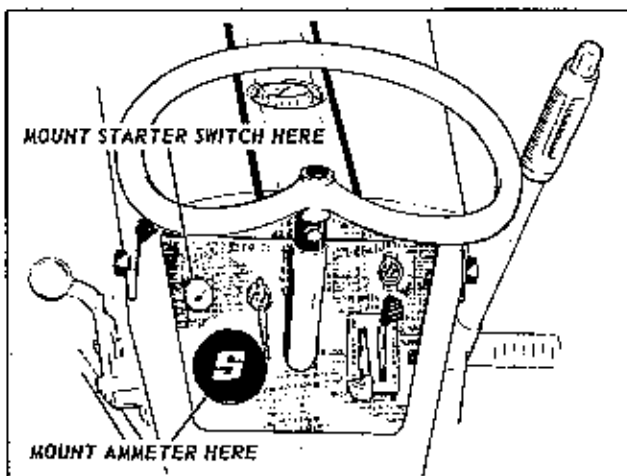

Figure 7

8. At this point it will be necessary for you to refer to the exploded-view illustration of the starter-generator system for proper identification of parts called out in the following paragraphs. As previously mentioned at the point of installation of the voltage regulator, two small diameter wires of equal length are furnished with the starter-generator kit, one has been fastened to the terminal on the underside of the voltage regulator, and the other small diameter wire is to be fastened to the "F" terminal on the front of the voltage regulator. Slip the smaller diameter rubber terminal cover over the end of wire connected to the underside of the voltage regulator and attach wire to "A" terminal on the starter generator as shown at #4, Fig. 6.

Pass the wire from the "F" terminal on the voltage regulator and one end of the long fabric covered wire through the larger diameter rubber terminal cover and connect to the "P" terminal of the starter-generator. Secure with hex nuts and lockwashers. Slide the terminal covers in place over the terminals of wires and starter-generator as shown at #4, Fig. 6.

Attach the U-shaped terminal on the end of the longest small diameter wire to the "Batt" terminal on the voltage regulator and pass the other end of the wire behind the starter support bracket and under the cylinder cooling fins of the engine, to the left side of the tractor and back through the rubber grommet in the fuel tank support bracket. Note that the ignition shorting runs through the same grommet. Connect the end of the wire to the right terminal of the ammeter (as viewed from the rear of the tractor) and secure with hex nut and lockwasher.

The free end of the long fabric covered wire follows the same path from the "A" terminal on the starter-generator and down under the engine cylinder fins towards the left side of the tractor and through the grommet in the fuel tank support bracket. Attach the end of the fabric covered wire to the right hand terminal of the starter switch (as viewed from the rear of the tractor) and secure with a hex nut and lockwasher.

Select the large rubber covered battery cable "Z" and attach the small terminal end along with the larger terminal end of the short wire "BI", with fuse holder to the left hand terminal of the starter switch (as viewed from the rear of the tractor). Secure with hex nut and lockwasher. The other short wire "CG" is connected to the left hand terminal of the ammeter (as viewed from the rear of the tractor). Secure with hex nut and lockwasher. Install fuse and holder in clip on left side panel as shown in Figure 8.

Install the battery support bracket "BB" as shown, between the steering column support and the fuel tank support. See details on Page 6. Use four hex capscrews, lockwashers, and hex nuts to secure the battery bracket in place. Charge the battery according to the Battery Manufacturer's Instructions.

Place the battery in position between the fuel tank and the dash panel, with the battery resting on the battery support. The terminals of the battery are to face toward the rear of the tractor. Connect the battery clamp of the heavy cable #1, Fig. 8, from the starter switch to the positive terminal of the battery. Install the battery hold-down bracket as shown at #2, Fig. 8. Place the terminal of the ground wire #3, Fig. 8, over the hex capscrew holding the battery clamp in position and secure with hex nut and lockwasher. Connect the ground wire to the battery (negative terminal) as shown at #4, Fig. 8. Re-check all terminal connections for tightness and place the battery insulation sheet over the battery bending the ends of the insulation to wrap down over the ends of the battery. Replace and fasten the tractor hood.

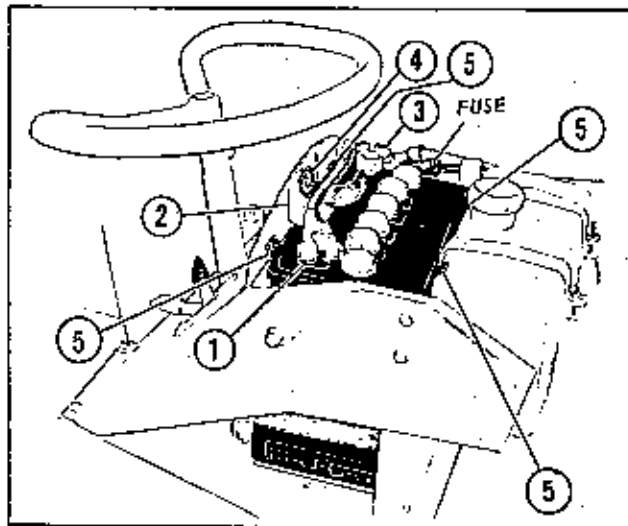

Figure 8

INSTALL THE (4) FELT GASKETS TO THE GAS TANK AND TO THE DASH ASSEMBLY AS SHOWN AT #5, FIG. 8.

STARTING INSTRUCTIONS

1. Sit on the tractor seat, and insert ignition key into switch.
2. Depress the clutch pedal with the right foot until the brake is applied to the wheels.
3. Shift the transmission into Neutral position.
4. Move the choke lever to ON position.
5. Move the throttle control to about $\frac{1}{2}$ ON position.
6. Depress the starter switch button and allow the starter to crank the engine.
7. As the engine fires, release the starter button, and slowly decrease the amount of choke until engine runs without choke.
8. Regulate the throttle lever to give desired engine speed, shift transmission into gear, and release clutch pedal to allow tractor to move.

The Starter-Generator, Voltage Regulator, and Ignition Switch are products of Delco-Remy, and are serviced by authorized UNITED MOTORS SERVICE dealers.

For the address of your nearest UNITED MOTORS SERVICE dealer, refer to the "Yellow Pages" of your telephone directory.

BATTERY INSTRUCTIONS

With proper care this battery should give the long service life built into it.

A battery which does not function properly is not necessarily worn out or defective. It may only need a good recharge. Therefore, if battery trouble is suspected, a full recharge and test by a competent battery man is recommended.

Putting Dry-Charged Batteries in Service

Remove wicks or tape covering from vent hole in filler caps. Make sure vent holes are open so battery gases produced when battery is charging can escape. If necessary, run a fine wire in vent hole to be sure it is open and free of all obstructions.

Fill battery with 1.265 specific gravity electrolyte or acid to proper level or $3/16$ inch above plates and separators assuming room, battery, and electrolyte temperature is 70°-100° Fahrenheit.

Allow battery to set for 20 minutes. Battery can then be installed but to obtain best results and maximum capacity, place battery on charge after the 20-minute setting period at 6 amperes until gravity reading is 1.265-1.275. If room, battery and electrolyte temperatures are below normal a longer charging period will be mandatory to bring the specific gravity up to 1.265-1.275.

Warning

Under no conditions should battery be filled more than $3/16$ " over the plates. We cannot be responsible for damages if this warning is not observed.

Care in Service

A hydrometer test of the battery solution should be made monthly. If the specific gravity tests 1.225 or less, the battery should be removed and thoroughly recharged. At the same time the solution level should be examined and distilled water added when necessary to retain the level of $3/16$ " over the plates. When necessary to add distilled water it should always be done just prior to recharging to mix the added water thoroughly into the solution.

When recharging is necessary and user does not have his own charging equipment, he should request service station to slow charge the battery at a rate of 4 to 6 amperes.

Any collection of grease or any other substance should be kept removed from the top of the battery and the top kept dry and clean at all times. The battery should be kept snug in its cradle and not permitted to get loose. If removed for charging, it should be fastened back in snugly enough to prevent any movement when in use. Vent caps should be kept tight and the small vent holes in top or side of cap be kept open at all times to permit escape of gases formed in the battery. Care should be exercised not to overfill the battery at any time and to always retain $3/16$ " of solution above the plates.

Winter Care

If battery will not be used during the winter months it should be removed and stored in a cool, dry place. Any collection of grease or other substance should be removed from the top of the battery.

The battery must be recharged monthly or whenever the hydrometer reads less than 1.225. Before reinstalling the battery in the spring, it should always be given a thorough recharge.

Correspondence concerning the Battery is to be addressed to:

WISCO DIVISION,
The Electric Storage Battery Co.
1222 18th Street
Racine, Wisconsin

ELECTRIC STARTER-GENERATOR SYSTEM

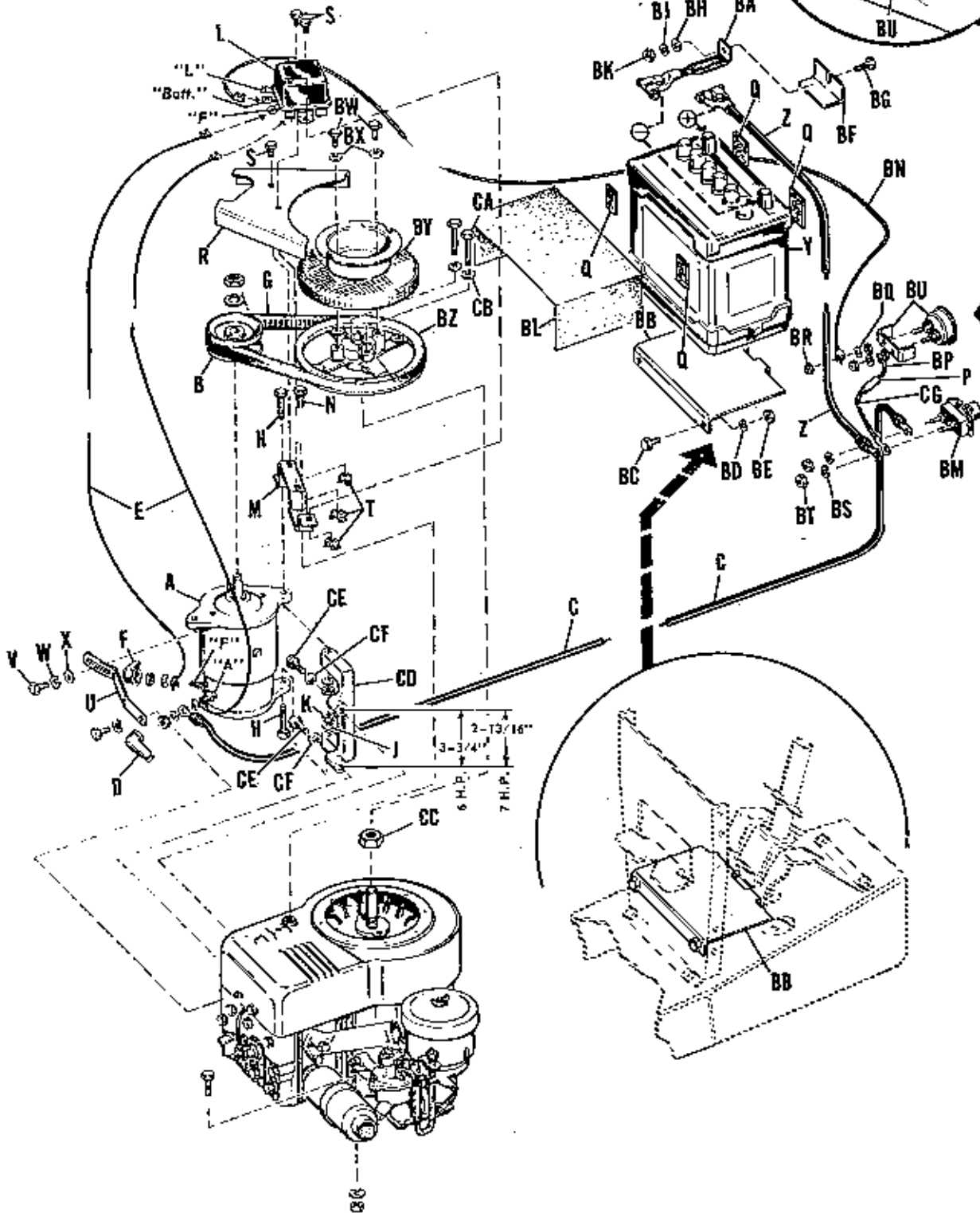
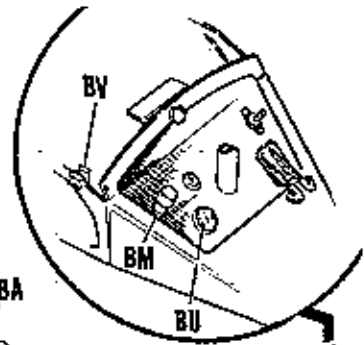
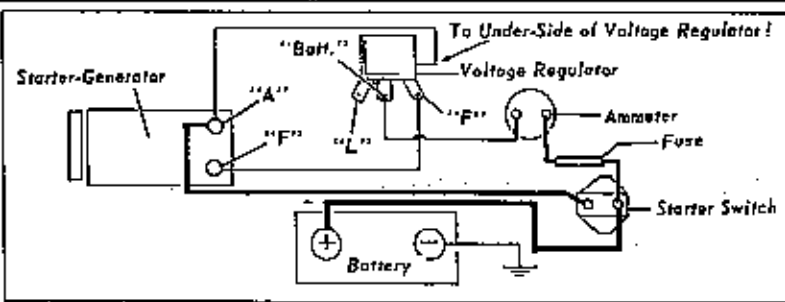

PARTS LIST

Ref. Letter	Part No.	Description
A	122136	Motor-Generator
B	122132	Generator Pulley
C	122117	Cable (Generator to Switch)
D	122023	Terminal Cover
E	122119	Wire
F	122116	Terminal Cover
G	122120	"V"-Belt
H	705023	Hex Capscrew, 5/16"-18 x 1-3/4" lg.
J	720001	Lock Washer, 5/16"
K	717001	Hex Nut, Full, 5/16"-18
L	122044	Voltage Regulator
M	122133	Regulator Bracket
N	705015	Hex Capscrew, 1/4"-20 x 5/8" lg.
P	122172	Fuse - 20 Amp
Q	106582	Felt Gasket
R	122137	Pulley Guard
S	705015	Hex Capscrew, 1/4"-20 x 5/8" lg.
T	718032	Tinnerman Nut
U	122134	Adjustment Strap
V	705017	Hex Capscrew, 5/16"-18 x 3/4" lg.
W	719002	Plain Washer, 5/16"
X	720001	Lock Washer, 5/16"
Y	122190	Battery
Z	122129	Battery Cable
BA	122130	Ground Cable
BB	156228	Battery Support
BC	705015	Hex Capscrew, 1/4"-20 x 5/8" lg.
BD	720003	Lock Washer, 1/4"
BE	717005	Hex Nut, Full, 1/4"-20
BF	156045	Battery Clamp
BG	705030	Hex Capscrew, 1/4"-20 x 3/4" lg.
BH	719006	Plain Washer, 1/4"
BJ	720003	Lock Washer, 1/4"
BK	717005	Hex Nut, Full, 1/4"-20
BL	122121	Battery Insulation
BM	122046	Starter Switch
BN	122118	Wire (Starter Switch to Regulator)
BP	122180	Wire (fuse to Ammeter)
BQ	720002	Lock Washer, 3/8"
BR	717003	Hex Nut, Full, 3/8"-16
BS	720003	Lock Washer, 1/4"
BT	717005	Hex Nut, Full, 1/4"-20
BU	122131	Ammeter
BV	122188	Clip, Fuse
BW	705017	Hex Capscrew, 5/16"-18 x 3/4" lg.
BX	720003	Lock Washer, 1/4"
BY	122188	Pulley and Screen
BZ	122122	Pulley, Electric Starter
CA	715053	Hex Capscrew, 1/4"-20 x 2-1/4" lg.
CB	720001	Lock Washer, 5/16"
CC	122125	Flywheel Nut
CD	122126	Starter Mounting Bracket 6 HP Only (122189 7 HP Only)
CE	705023	Hex Capscrew, 5/16"-18 x 1-3/4" lg.
CF	720001	Lock Washer, 5/16"
CG	122181	Wire (fuse to Starter Switch)

