

Simplicity®

LOW SPEED PULLEY KIT

Mfr's. No. 324

1. Place a suitable support beneath the tractor transmission to hold it in a raised position with the rear wheels off of the ground. Remove the right hand rear wheel by pulling the cotter pin and pin from the axle and wheel hub, and pull the wheel and hub away from the tractor. Note that it is not necessary to remove the wheels bolts to remove the wheel from tractor.

Release the idler pulley from the transmission drive belt by unhooking the spring #1, Fig. 6, and allowing the idler arm #2, Fig 6 to swing downward.

Remove the transmission drive pulley from the shaft by loosening the set screw in the pulley hub and pulling the pulley away from the transmission.

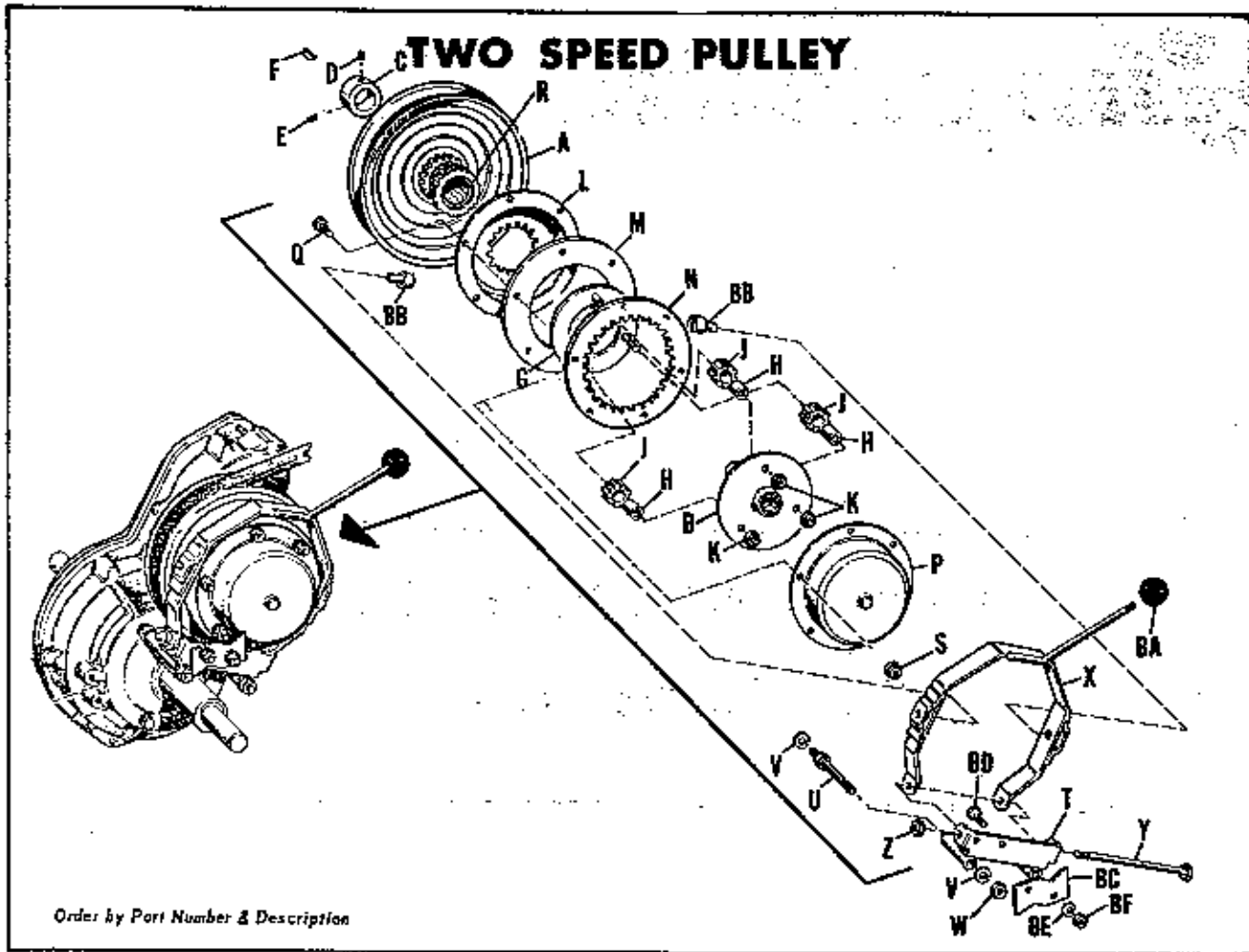

Ref. Letter	Part No.	Description
A	156233	Pulley & Gear Assembly
B	156238	Spider & Bearing Assembly
C	154065	Set Collar
D	713501	Set Screw, Socket Hd., Cup Pt., 5/16"-18 x 1/2" lg.
E	713504	Set Screw, Socket Hd., Cup Pt., 5/16"-18 x 3/8" lg.
F	725003	Woodruff Key
G	156246	Ring Assembly
H	121163	Spacer
I	121118	Pinion
K	717510	Hex Nut, Full, 3/8"-16
L	121148	Cover Assembly
M	156249	Shift Ring
N	121151	Gear Ring
P	156250	Cover Assembly, Right Hand
Q	715018	Hex Capscrew, 1/4"-20 x 5/8" lg.
R	156237	Bushing (2 Required)
S	718034	Nut Flange, Whiz Lock, 1/4"-20
T	156253	Pivot Bracket Assembly
U	156255	Stud
V	720003	Lock Washer, 3/8"
W	717003	Hex Nut, Full, 3/8"-16
X	156257	Shift Fork Assembly
Y	705060	Hex Capscrew, 5/16"-18 x 6-1/2" lg.
Z	717511	Hex Nut, Full, Lock, 5/16"-18
BA	8021050	Knob
BB	156261	Shift Pivot
BC	156262	Stop
BD	705017	Hex Capscrew, 5/16"-18 x 3/4" lg.
BE	720001	Lock Washer, 5/16"
BF	717001	Hex Nut, Full, 5/16"-18

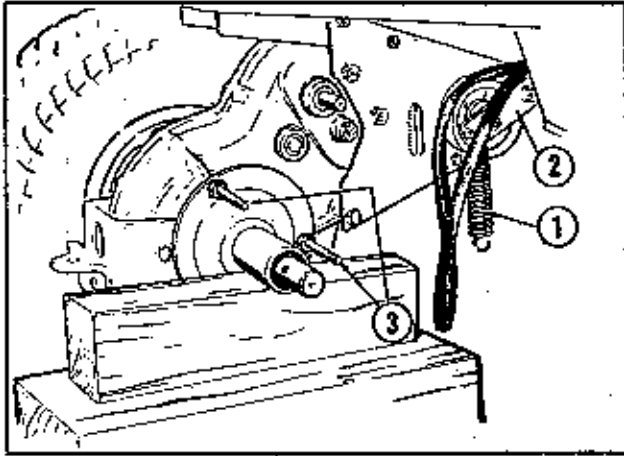

Figure 6

2. Remove two hex capscrews from the transmission case and insert the two long studs #3, Fig. 6, into the vacant bolt holes as shown. Tighten securely.

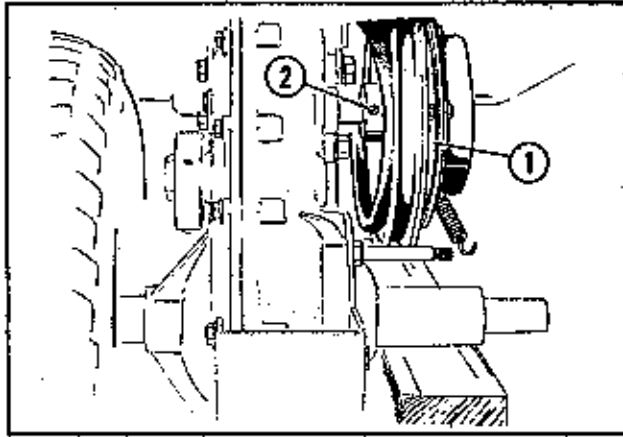

Figure 7

3. Place the two-speed pulley assembly #1, Fig. 7, on the transmission pulley shaft, and lock in place with the set-screw #2, Fig. 7, in the pulley hub. Be sure to maintain a clearance of at least 1/8" between the pulley hub and the transmission. Notice that the hub of the pulley faces toward the transmission. Place the V-belt over the two-speed pulley #2, Fig. 8, and replace the idler tension spring #3, Fig. 8, in the hole #4, Fig. 8 as shown, to engage the idler pulley with the transmission drive belt.

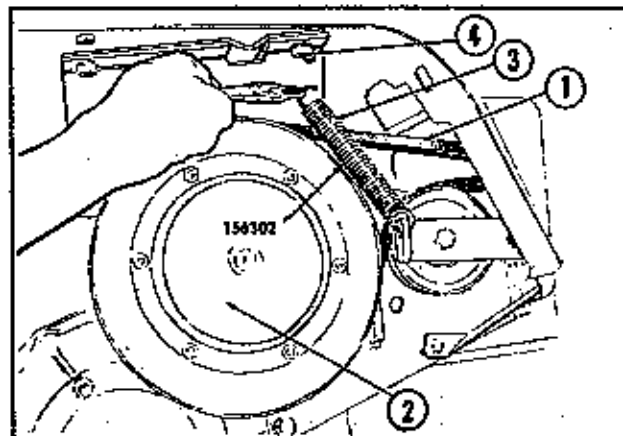

Figure 8

4. Insert the shifter yoke handle #1, Fig. 9, through the hole #2 Fig. 9, in the seat support. Assemble the shifter yoke #3, Fig. 9, to the narrow rim of the gear cover assembly, #4, Fig. 9. Slide the two slotted-shift pivots #5, Fig. 9, into position astride the flanged gear cover assembly.

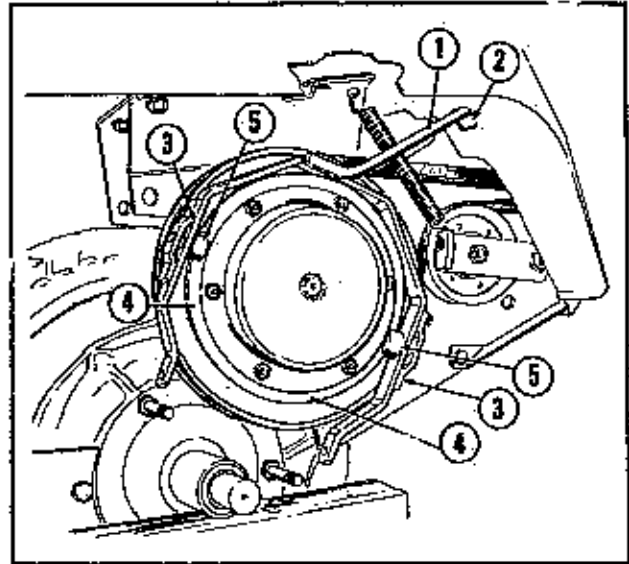

Figure 9

5. Assemble the pivot bracket assembly #1, Fig. 10, over the two studs as shown in Fig. 10, and fasten securely with two 3/8" lockwashers and 3/8"-16 hex nuts. Align the two holes #2, Fig. 10 in the end of the shift fork assembly with the two holes in the pivot bracket and secure with a 5/16"-18 x 6 1/2" lg. hex capscrew #3, Fig. 10, and 5/16"-18 hex lock nut. Avoid overtightening this bolt, as the shift fork assembly must be able to pivot freely.

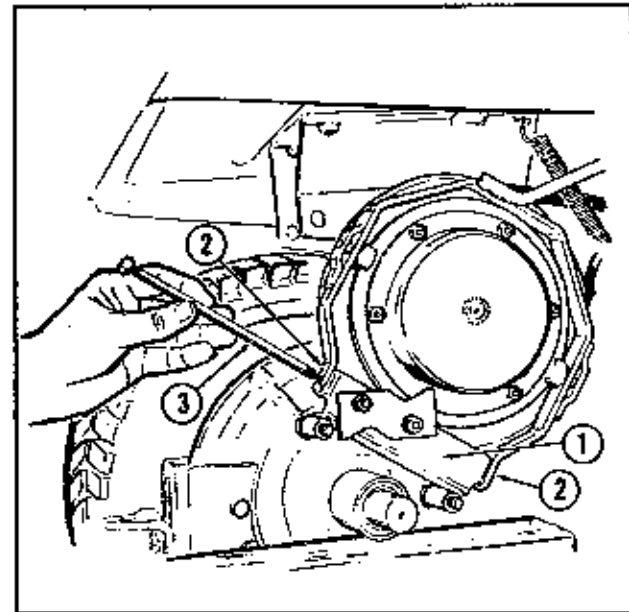

Figure 10

6. Install the shift knob on the end of the shift fork rod.

7. Re-install the wheel and hub, and secure with the pin and cotter pin to hold wheel and hub to axle.

WARRANTY

The company warrants Simplicity Products to be free from defects in material and workmanship except the company makes no warranty express or implied with respect to tires, engines and engine accessories which generally are warranted by their respective manufacturers. Any part covered by this warranty which is proven defective within one year, under normal use, from date of purchase, will be replaced free of charge, f.o.b. Port Washington, Wisconsin, provided such part is returned to factory transportation charges prepaid and is found to be defective upon examination at the factory. The company is not obligated under this warranty to bear cost of labor or delivery charges in replacement of defective parts. This warranty does not apply to any Simplicity Products altered outside of Simplicity's factory. Such replacement of defective parts shall be the exclusive remedy and in no event shall Simplicity be liable for consequential damages. EXCEPT AS SPECIFICALLY PROVIDED HEREIN, THERE ARE NO WARRANTIES WHICH EXTEND BEYOND THE DESCRIPTION ON ANY SIMPLICITY PRODUCT.

Should warranty service be necessary, the information below should be presented to the authorized SIMPLICITY Dealer.

Customer's Name _____

Address _____

Mfg. No. _____ Serial No. _____

Date Purchased _____

Purchased From _____

Address _____

Engine Model No. _____ Serial No. _____ Type No. _____

To obtain replacement parts from dealer, advise quantity, part number and description.

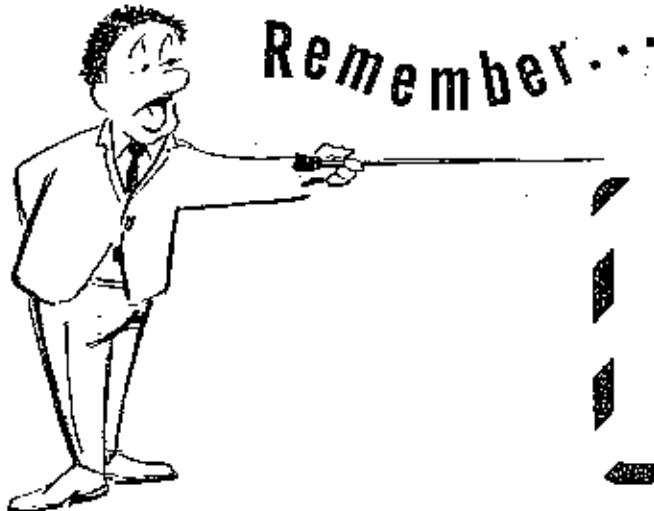

FOR YOUR SAFETY

1. ALWAYS STOP ENGINE BEFORE LEAVING MACHINE
2. ALWAYS STOP ENGINE BEFORE SERVICING OR ADJUSTING MACHINE OR EQUIPMENT
3. ALWAYS KEEP HANDS, FEET AND CLOTHING AWAY FROM POWER-DRIVEN PARTS