

Simplicity

42" ROTARY MOWER Mfrs. No. 575

**ADAPTER KIT
Mfrs. No. 620**

**LEAF MULCHER
Mfrs. No. 284**

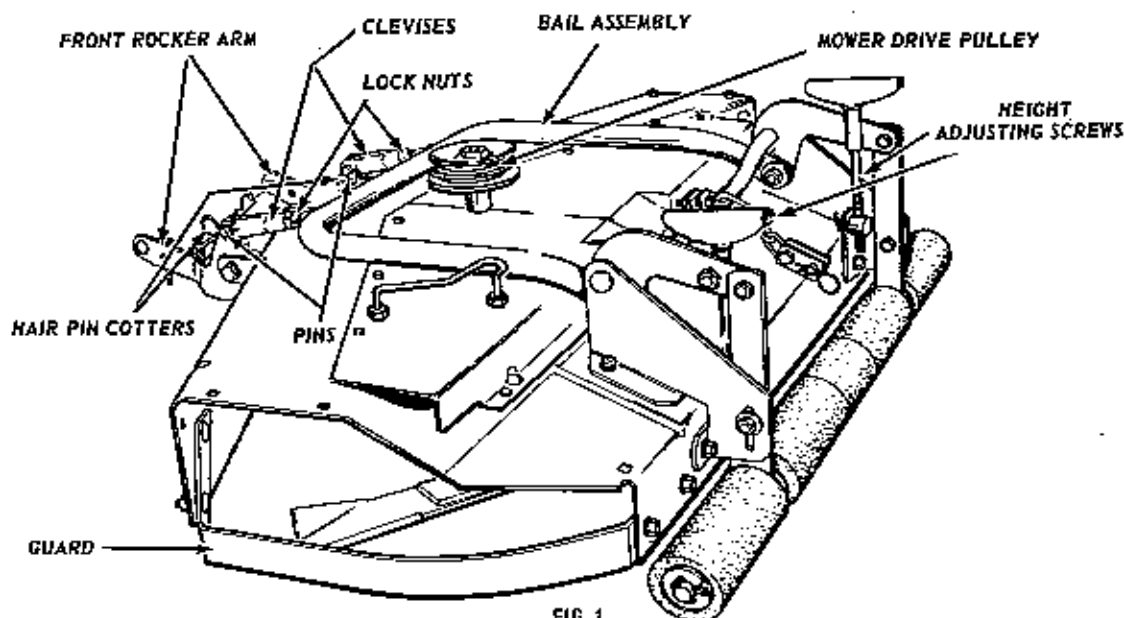

FIG. 1

Attachment

To attach the 42" Rotary Mower to the Tractor, follow the sequence of steps as outlined below:

1. Place the mower beside the tractor, and turn the tractor wheels to full left position. Before sliding the mower under the tractor, remove the hair pin cotters and pins connecting the clevises on front end of bail assembly. Allow the rocker arms to drop down. This will now provide sufficient clearance for the mower to slide under the tractor. With the mower under the tractor, replace the clevises on rocker arms and fasten with hair pin cotters and pins.
2. Connect the rocker arms to front mounting brackets under the tractor, by using pins and hair pin cotters as shown in figure 2.
3. Place the tractor lift lever in its rear position and attach the mower lift lever to the tractor lift arm on right hand side of tractor as shown in figure 3. Use hex capscrew, flatwashers, and hex nut furnished for this purpose.
4. Connect the mower lift chain to the lift lever by fastening the lift links in place with a pin and hair cotter as shown in figure 3.
5. Place the cross drive belt in position on the mower drive pulley. Give the belt a 90° twist towards the left hand side of the tractor and mount belt to larger pulley of power take-off as shown in figure 3. When installed in proper manner, the belt should run from the left side of the mower pulley to bottom side of power take-off pulley.

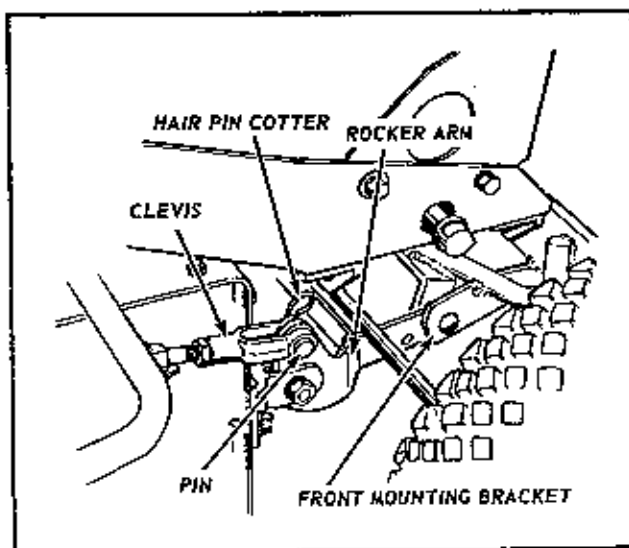

FIG. 2

Adjustments

To check the final adjustment of the mower height, place the tractor with the mower attached, on a smooth flat surface. Rotate the center blade to the front and measure the distance from its front tip to the ground. Then rotate each of the side blades so that their tips can be measured at the front. For best mowing results, the leading tip of the center blade should be about $\frac{1}{4}$ " higher than the trailing tip of the two side blades. To obtain this adjustment, remove pins from clevises and rocker arms, loosen the hex nut in back of each clevis and turn each clevis in or out sufficiently to achieve this setting. In making this adjustment, be sure that both clevises are adjusted equally.

SIMPLICITY MANUFACTURING COMPANY

TP - 1322

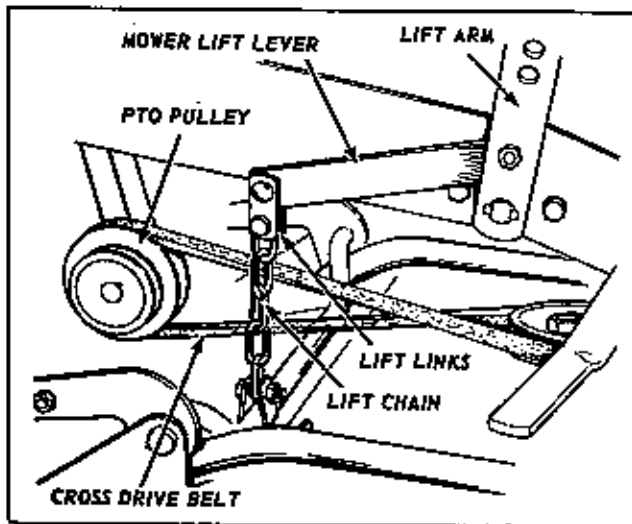

FIG. 3

Operation

1. Set mower to desired height of cut by turning the adjusting screw handles counter-clockwise to lower the cut, and clockwise to raise the cut. Turn each adjusting handle an equal number of times to insure level operation.
2. Start the tractor engine with the power take-off in the disengaged position, and lower the mower to cutting position by releasing the tractor lift lever.
3. Engage the power take-off to set the mower blades in operation; engage the tractor clutch and proceed with mowing.
4. To transport the mower; disengage the power take-off to stop blades. Raise the mower above the surface by pushing the tractor lift lever to forward locked position.

Belt Tension

The mower spindle drive belt is spring loaded and requires no further adjustment.

NOTE: The cross drive belt and the blade drive belt are a low stretch, high strength, polyester, "W" design belt and are designed and manufactured to provide long and satisfactory service. Because of the special design of these belts, it is urged that you replace them only with genuine replacement belts ordered from your dealer. Consult the parts list for the correct part numbers for these belts when replacement is necessary.

Lubrication

The mower arbor spindles are supported in pre-lubricated, sealed ball bearing assemblies, which do not require further attention.

CAUTION

MOWER SHALL NOT BE USED WITHOUT EITHER VACUUM COLLECTOR ADAPTER OR THE DEFLECTOR ADAPTER IN PLACE.

IMPORTANT

USE ONLY SIMPLICITY REPLACEMENT BELTS & BLADES

Caution

It is the responsibility of the operator to see that the area where the mower will be used is free of all types of foreign material. This includes wire, rope, rags, sticks, bottles, cans, pipe, and rocks, etc. These represent potential dangers to mower, operator, and spectators; as well as having a dulling effect on the mower blades.

Always guard for obstacles when mowing, and, never leave mower running while unattended.

Disengage mower and inspect for damage immediately after striking a foreign object. Insure that damage has been repaired before using mower.

LEAF MULCHER

To install the leaf mulcher, remove the mower from the tractor, and follow the sequence of steps as shown below.

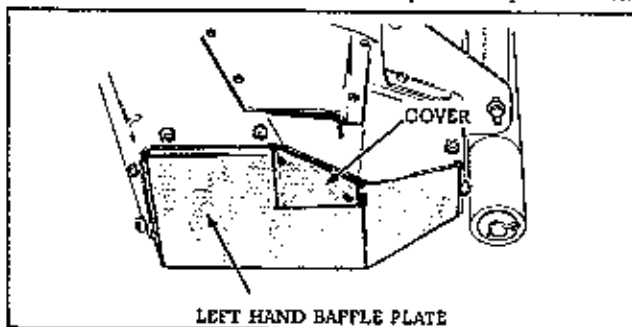

FIG. 4

1. Remove the guard assembly from the discharge opening of mower housing. Install the Left Hand Baffle Plate as shown in Figure 4. This baffle is held in place by 7 carriage bolts, lockwashers, and hex nuts. Note that the lockwashers and nuts are on the exterior of mower housing.

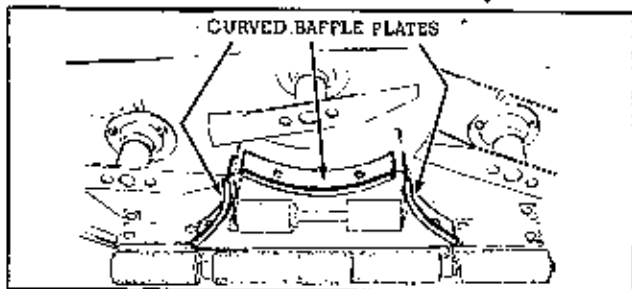

FIG. 6

3. Install the curved mulcher baffles (Left Hand, Right Hand, and Center) as shown in Figure 6. These baffles are each held in place by 2 carriage bolts, lockwashers, and hex nuts. Note that lockwashers, and hex nuts are on the inside of the baffle support.

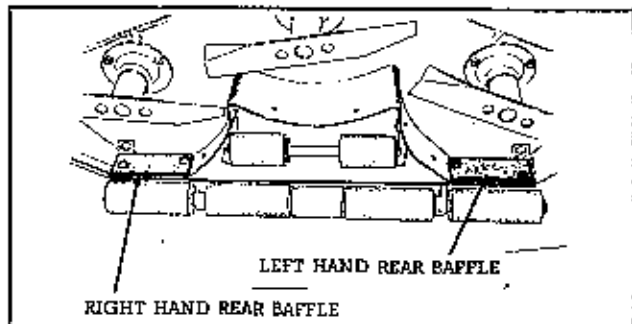

FIG. 5

2. Install the Left Hand and Right Hand Rear Baffle Plates as shown in Figure 5. These baffles are each held in place by 2 carriage bolts, lockwashers, and hex nuts. Note that the lockwashers and nuts are on the exterior of mower housing.

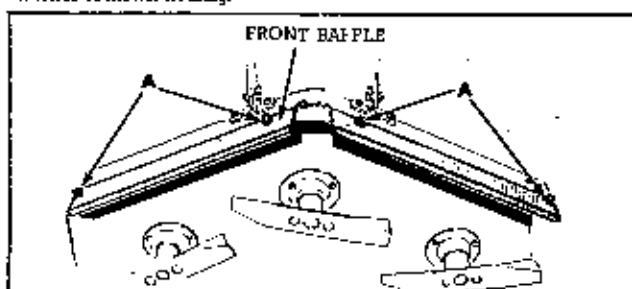
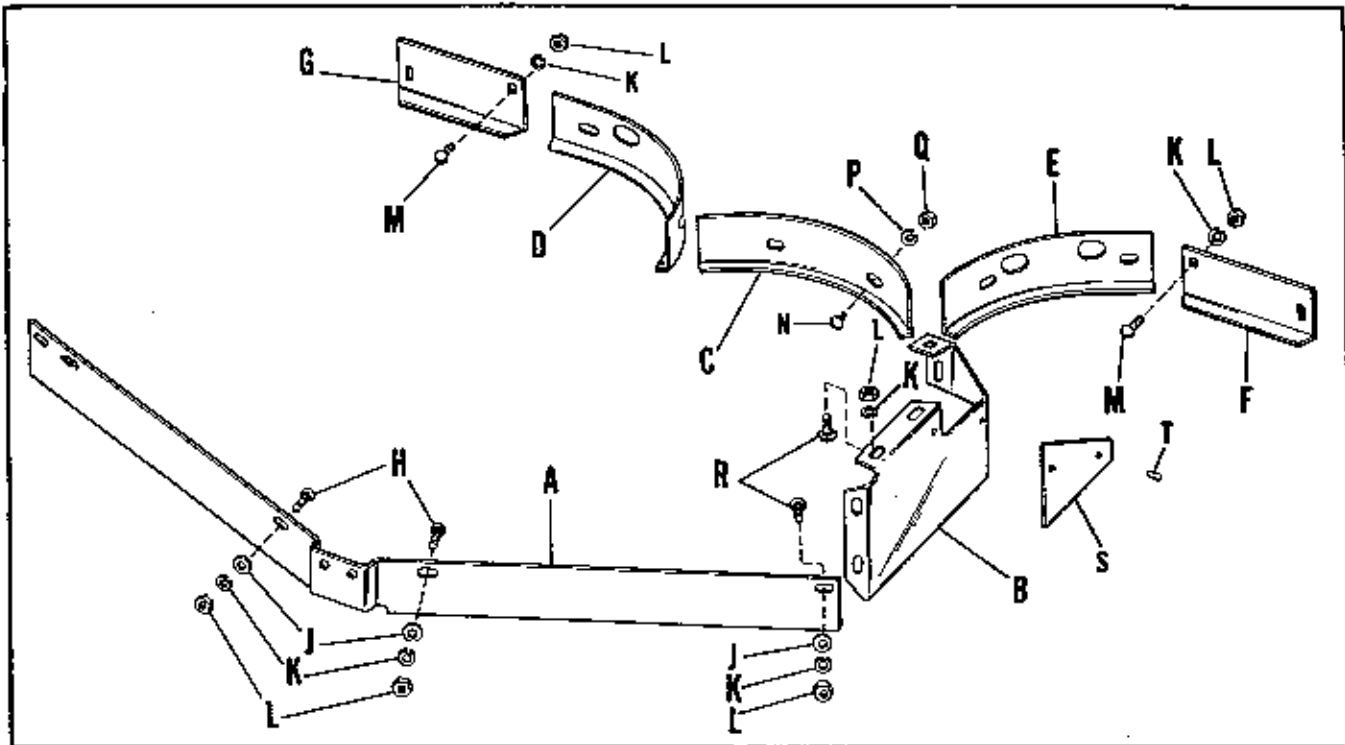

FIG. 7

4. Install the Front Baffle as shown in Figure 7. This baffle is held in place by 6 carriage bolts, lockwashers, and hex nuts. 4 plain, flat washers are furnished for use under the lockwashers at points "A". Note that the hex nuts and lockwashers are on the exterior of the mower housing.

LEAF MULCHER



Ref. Let.	Part No.	Description
A	108365	Baffle, Mulcher, Front
B	108363	Plate - End - Housing
C	108267	Baffle, Mulcher, Rear Center
D	108265	Baffle, Mulcher, Right Hand Side
E	108266	Baffle, Mulcher, Left Hand Side
F	108259	Baffle, Left Hand, Rear
G	108260	Baffle, Right Hand, Rear
H	703004	Carriage Bolt, 3/8"-16 NC x 3/4" w/short square neck

Ref. Let.	Part No.	Description
J	719001	Washer, Plain, 3/8" Std.
K	720002	Washer, Lock, 3/8"
L	717003	Nut, Hex, Full, 3/8"-16
M	702002	Carriage Bolt, 3/8"-16 x 1"
N	703006	Carriage Bolt, 5/16"-18 NC x 3/4" w/short square neck
P	720001	Washer, Lock, 5/16"
Q	717001	Nut, Hex, Full, 5/16"-18
R	702003	Carriage Bolt, 3/8"-16 x 3/4"
S	108364	Cover
T	714007	Screw, Rec. Hex. Hd. Self Tapping, 1/4"-20 x 3/8"

ADAPTER KIT

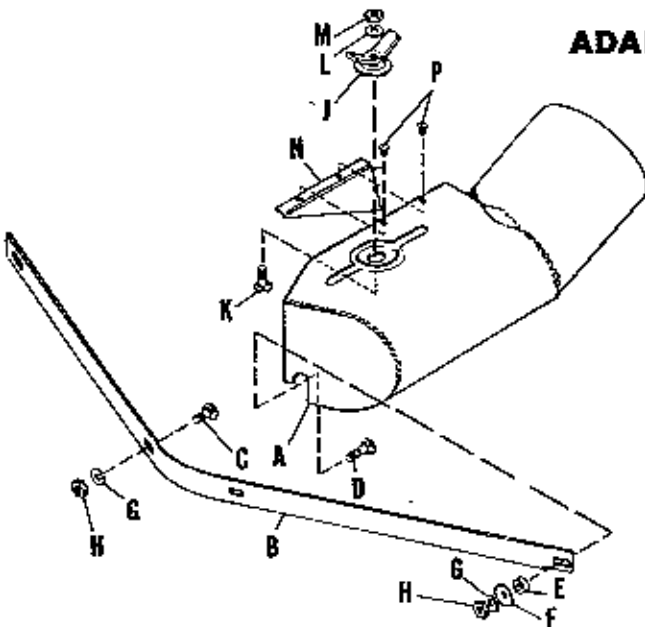

Ref. Let.	Part No.	Description
A	123137	Collector Side Housing Assy.
B	123059	Front Baffle
C	703003	Carriage Bolt, 3/8"-16 x 1"
D	703002	Carriage Bolt, 3/8"-16 x 1 1/4"
E	153081	Spacer
F	157169	Washer
G	720002	Lock Washer, 3/8"
H	717003	Nut, Hex, Full, 3/8"-16
J	123060	Nut Assembly
K	703003	Carriage Bolt, 3/8"-16 x 1"
L	720002	Lock Washer, 3/8"
M	717003	Nut, Hex, Full, 3/8"-16
N	123062	Baffle
P	714005	Screw, Self Tapping, No. 10-24 x 1/2"

BAIL ASSEMBLY

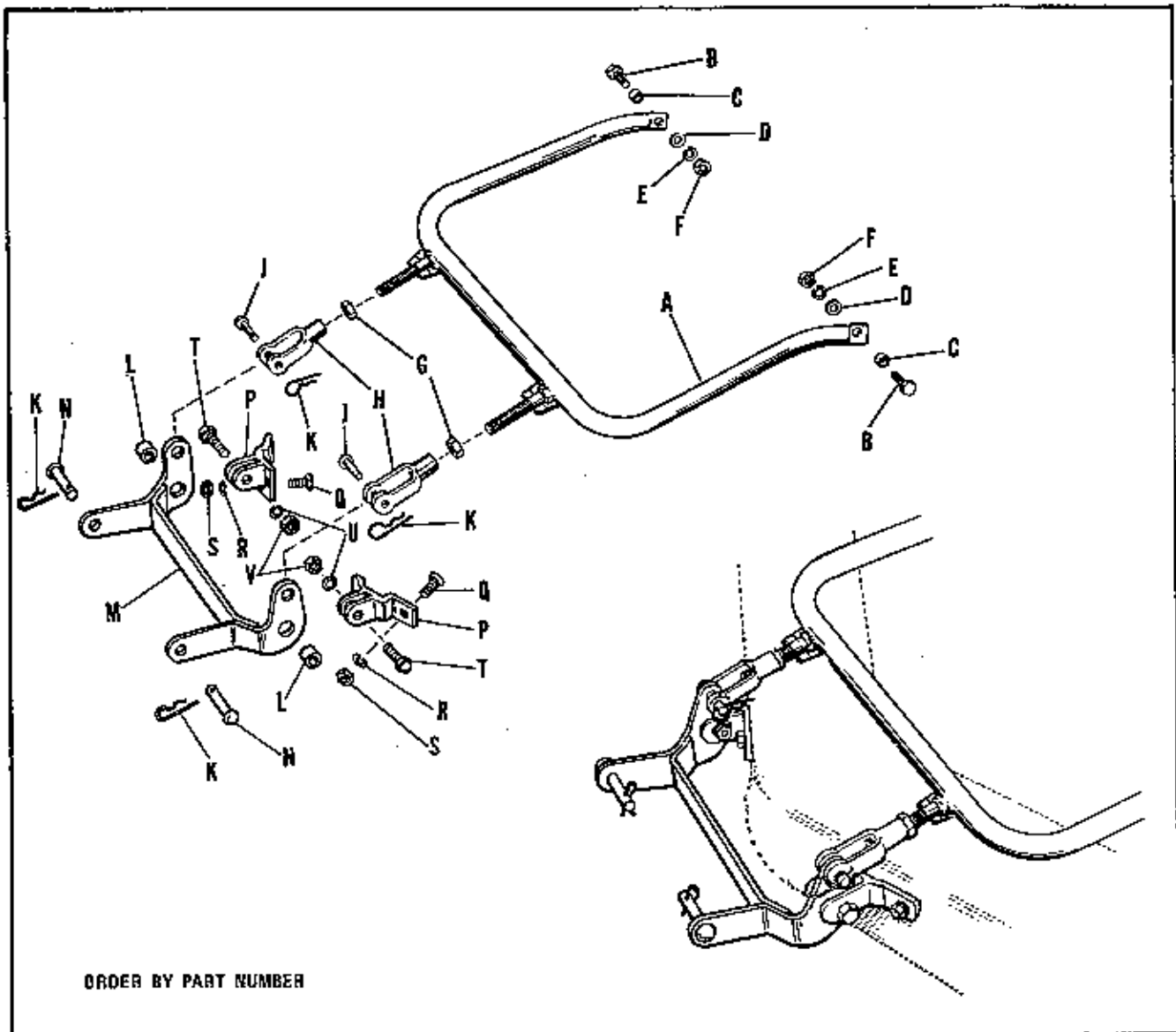

ORDER BY PART NUMBER

Ref. Let.	Part No.	Description
A	108229	Bail Assembly
B	705049	Capscrew, Hex Hd., 1/2"-13 NC x 1 1/4" lg.
C	105051	Spacer
D	719003	Washer, Plain, 7/16
E	720004	Washer, Lock, 1/2"
F	717006	Nut, Hex, Full, 1/2"-13 NC
G	717016	Nut, Hex, Jam, 1/2"-20 NF
H	154304	Yoke End, Adjusting
J	154305	Yoke Pin
K	8161045	Clip, Spring
L	105051	Spacer

Ref. Let.	Part No.	Description
M	108794	Rocker Arm
N	118053	Pin
P	108219	Bracket Assembly, Front
Q	702002	Bolt, Carriage, 3/8" - 16 NC x 1"
R	720002	Washer, Lock, 3/8"
S	717003	Nut, Hex, Full, 3/8" - 16 NC
T	705049	Capscrew, Hex, 1/2" - 13 NC x 1 1/4"
U	720004	Washer, Lock, 1/2" V
V	717006	Nut, Hex., Full, 1/2" - 13 NC

MOWER UNDERSIDE

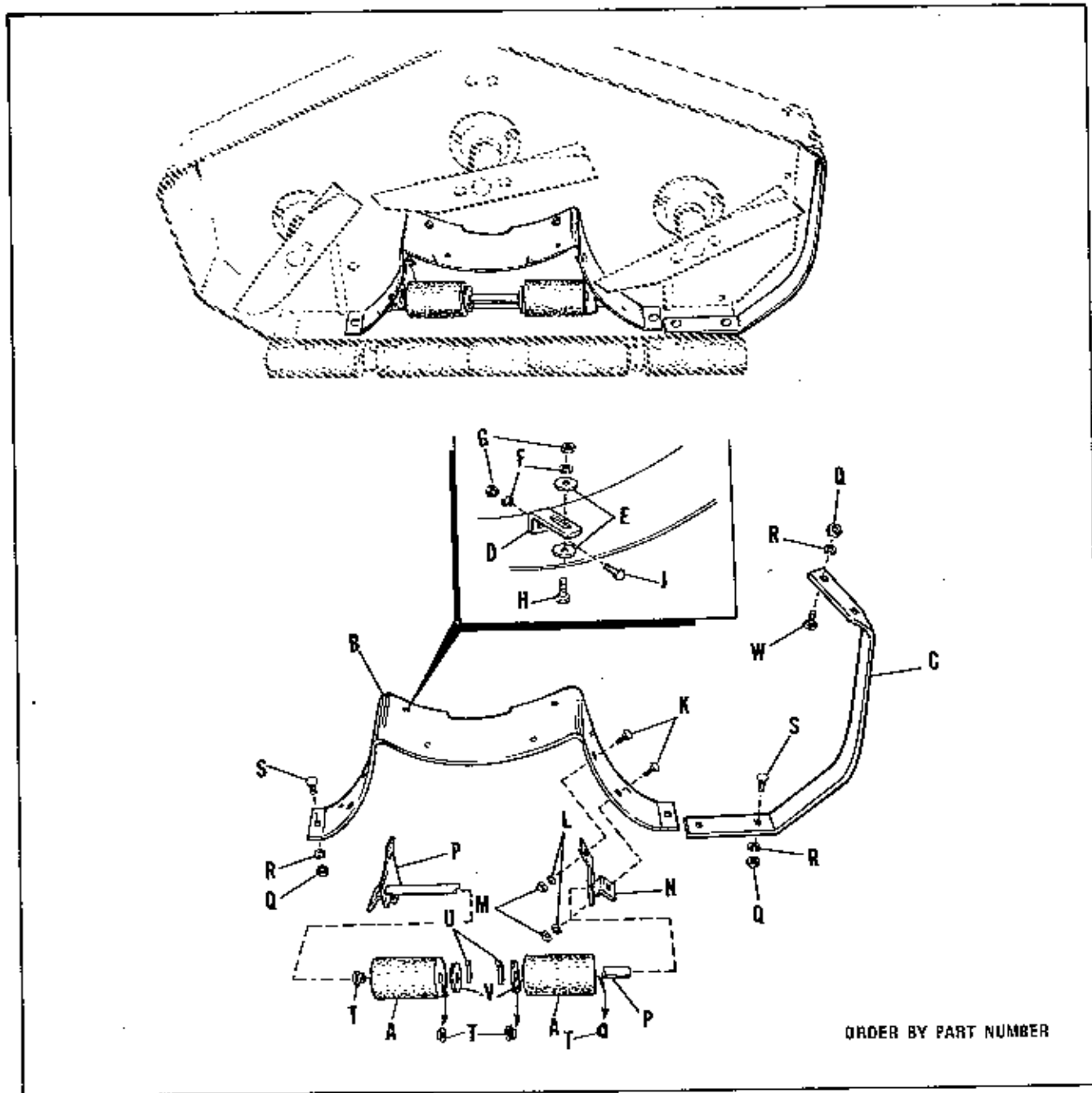

ORDER BY PART NUMBER

Ref. Let.	Part No.	Description
A	108431	Roller W/Bushing
B	108351	Baffle
C	108214	Guard Assembly, Housing
D	108186	Clip Baffle
E	719006	Washer, Plain, 1/4"
F	720003	Washer, Lock, 1/4"
G	717005	Nut, Hex, Full, 1/4" - 20 NC
H	715018	Capscrew, Hex, 1/4"-20 x 5/8" lg.
J	714012	Screw, Recessed Hex, Self-Tapping 1/4" - 20 NC x 7/8" lg.
K	702015	Bolt, Carriage, 5/16" - 18 NC x 3/4" lg.

Ref. Let.	Part No.	Description
L	720001	Washer, Lock, 5/16"
M	717001	Nut, Hex, Full, 5/16" - 18 NC
N	108224	Bracket, Roller, Lower, L.H.
P	108426	Bracket & Shaft Assembly
Q	717003	Nut, Hex, Full, 3/8"-16 NC
R	720002	Washer, Lock, 3/8"
S	702003	Bolt, Carriage, 3/8"-16 NC x 3/4" lg.
T	108419	Bushings
U	722011	Pin, Cotter, 3/16" x 1" lg.
V	116001	Washer
W	702002	Bolt, Carriage, 3/8"-16 NC x 1" lg.

DECK ASSEMBLY

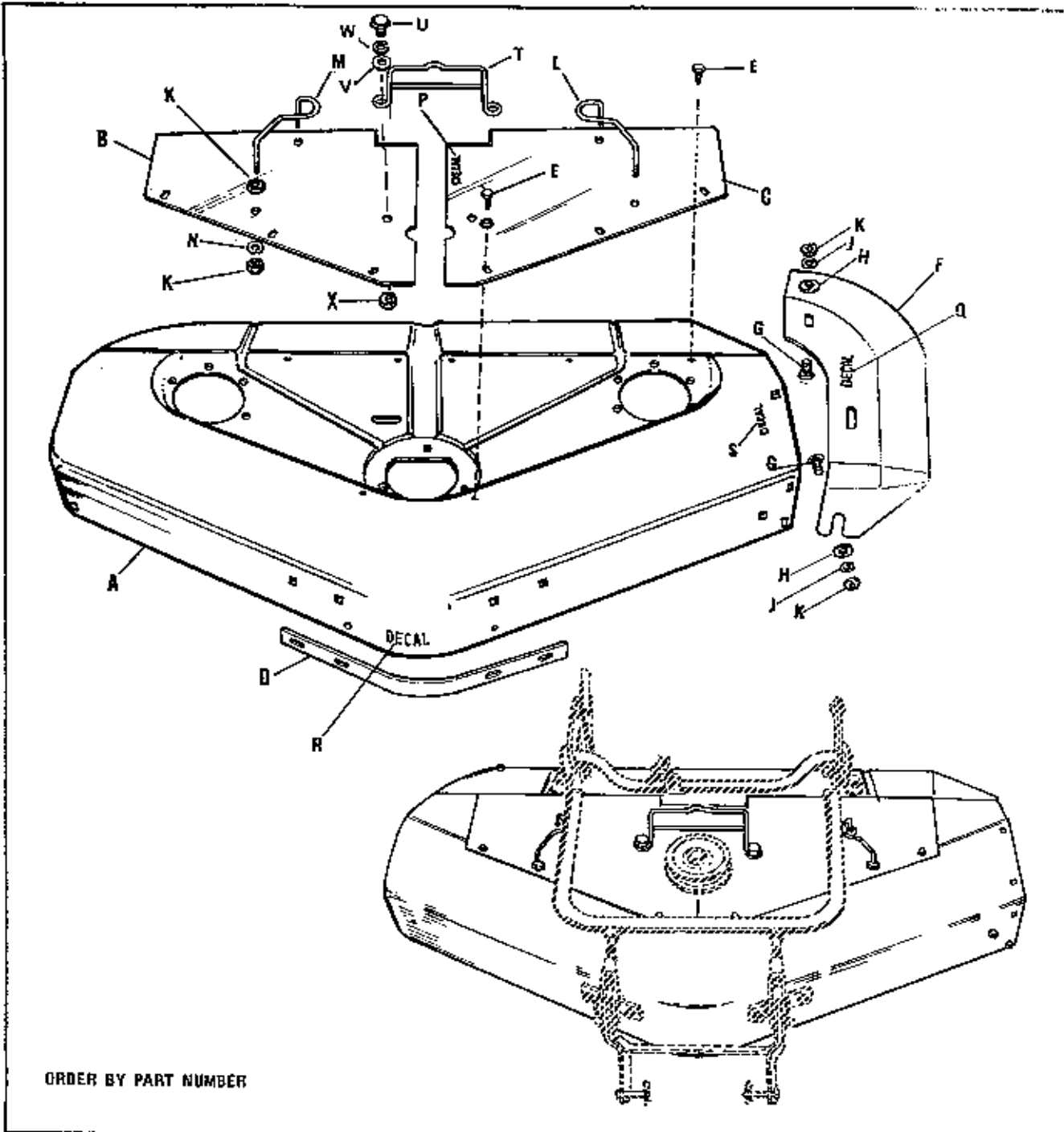

ORDER BY PART NUMBER

Ref. Let.	Part No.	Description
A	108354	Mower Housing
B	108420	Cover, R.H.
C	108421	Cover, L.H.
D	108366	Bar, Reinforcing
E	715067	Screw, Taptite, 1/4-20 x 3/8" lg.
F	108525	Deflector
G	703004	Carriage Bolt, 3/8"-16 x 3/4" lg.
H	8161199	Washer-Special
J	720002	Washer, Lock, 3/8"
K	717003	Hex Nut, Full, 3/8-16
L	157247	Guard, L.H.

Ref. Let.	Part No.	Description
M	157246	Guard, R.H.
N	719001	Washer, Plain, 3/8"
P	108102	Decal
Q	103031	Decal
R	106719	Decal
S	108507	Film, Safety
T	170012	Belt Guide Assembly
U	705017	Hex Cap Screw, 5/16-18 x 1/4 lg.
V	719002	Plain Washer 5/16
W	720001	Lock Washer, 5/16
X	718041	Nut Retainer
*	108828	Decal-Safety Stds.

* Not Illustrated

ROLLER ASSEMBLY

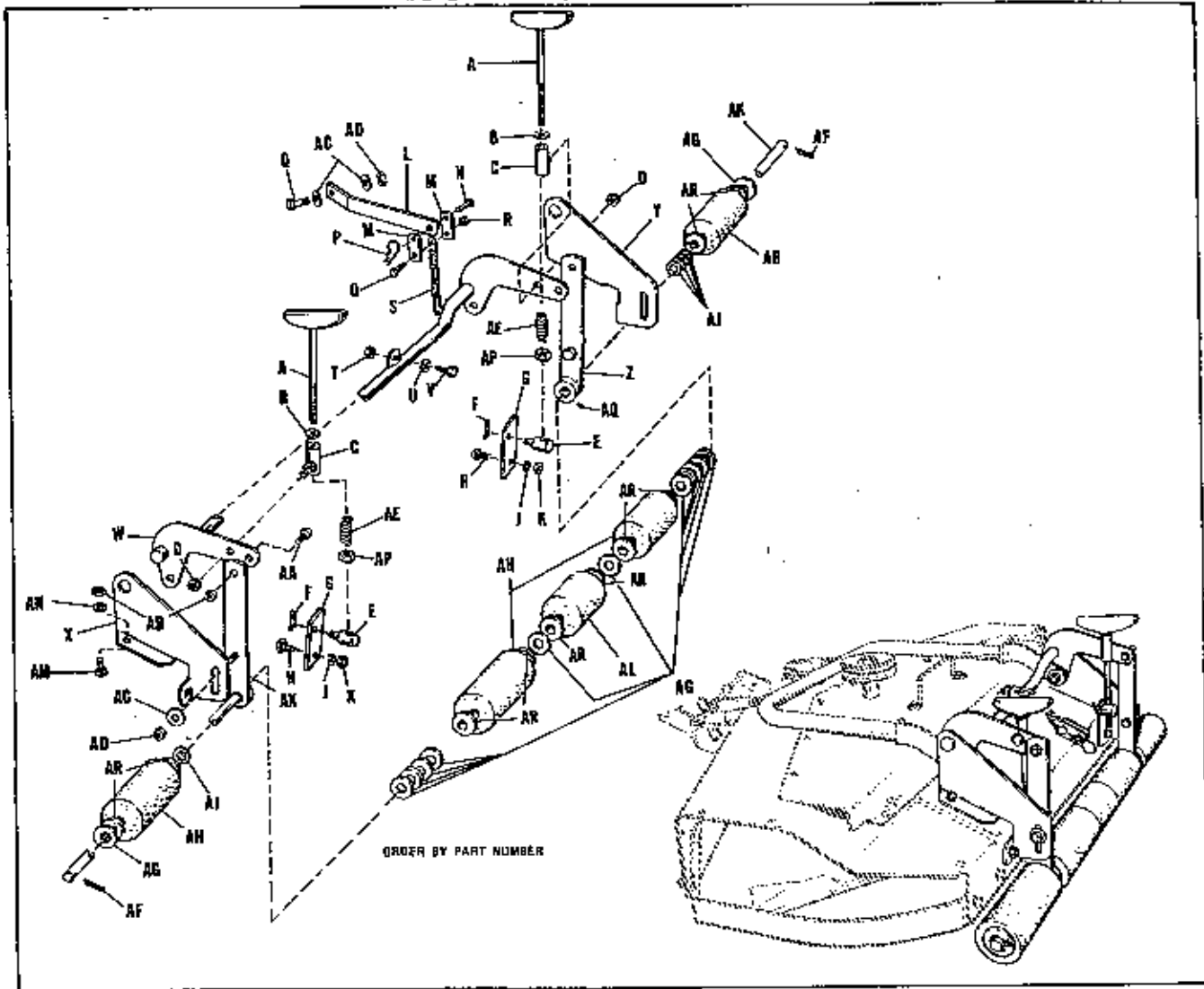

Ref. Let.	Part No.	Description
A	108415	Screw Assembly, Adjusting
B	719001	Washer, Plain, 3/8"
C	108241	Socket Assembly, Crank
D	717510	Nut, Hex, Full, Lock, 3/8"-16 NC
E	108172	Pivot
F	722001	Cotter Pin, 3/32" x 3/4" lg.
G	108242	Link, Lift
H	703004	Bolt, Carriage, 3/8"-16 NC x 3/4" lg.
J	720002	Washer, Lock, 3/8"
K	717003	Nut, Hex, Full, 3/8"-16 NC
L	108198	Lever, Mower Lift
M	108199	Link, Mower Lift
N	153058	Pin, Lock
P	8161045	Clip, Spring
Q	705005	Capscrew, Hex Hd., 3/8"-16 NC x 1" lg.
R	717510	Nut, Hex, Full, Lock, 3/8"-16 NC
S	101084	Chain
T	717510	Nut, Hex, Full, Lock, 3/8"-16 NC
U	719001	3/8" Washer
V	705005	Capscrew, Hex Hd., 3/8"-16 x 1" lg.

Ref. Let.	Part No.	Description
W	108424	Arm Assembly, Rocker
X	108234	Bracket, Roller, R.H.
Y	108233	Bracket, Roller, L.H.
Z	108359	Bar Assembly, Roller
AA	705005	Capscrew, Hex Hd., 3/8"-16 NC x 1" lg.
AB	717003	Nut, Hex, Full, 3/8"-16 NC
AC	719001	Washer, Plain, 3/8"
AD	717510	Nut, Hex, Full, Lock, 3/8"-16 NC
AE	108360	Spring, Adj. Screw
AF	722011	Pin, Cotter, 3/16" x 1" lg.
AG	116001	Washer
AH	108432	Roller W/Bushing
AJ	8261055	Washer
AK	108358	Shaft & Support Arm.
AL	108431	Roller W/Bushing
AM	702003	Bolt, Carriage, 3/8"-16 NC x 3/4" lg.
AN	720002	Washer, Lock, 3/8"
AP	717013	Nut, Hex, Full 3/8"-16 NC
AQ	713505	Set Screw 1/4"-20 NC x 5/16" lg.
AR	108419	Bushings

ORDER BY PART NUMBER

ARBOR ASSEMBLIES

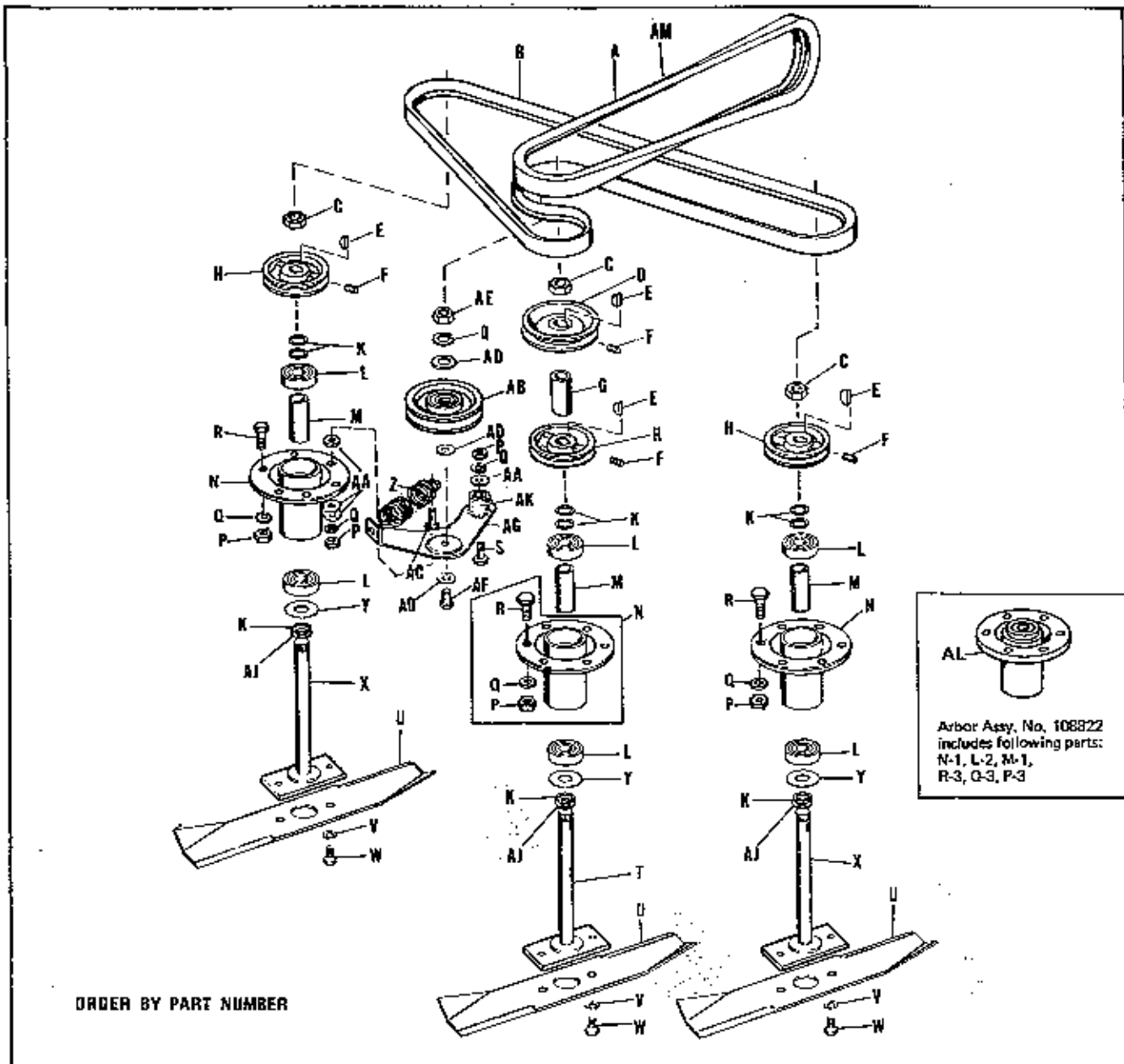

ORDER BY PART NUMBER

Ref. Let.	Part No.	Description
A	168171	Belt "V"
B	108209	Belt, "V" (Mower Spindle Drive)
C	717517	Hex, Jam Lock Nut, 3/8"-16
D	170008	Cross drive Pulley
E	725006	Key, Woodruff, 61
F	713504	Set Screw, 5/16"-18 x 3/8"
G	108740	Spacer
H	108142	Pulley
K	108181	Washer
L	108202	Bearing
M	108201	Spacer
N	108679	Arbor Tube Assembly
P	717003	Full Hex, Nut, 3/8"-16
Q	720002	Lock Washer, 5/8"
R	705004	Hex Cap Screw, 3/8"-16 x 3/4" lg.
S	705010	Hex, Cap Screw 3/8"-16 x 1-3/4" lg.

Ref. Let.	Part No.	Description
T	108252	Arbor Drive Assembly
U	108298	Knife Blade
V	720002	Lock Washer, 5/8"
W	715024	Hex. Hd. Cap screw, 3/8"-16 x 5/8"
X	108250	Arbor Assembly
Y	108257	Washer
Z	154369	Spring
AA	719002	Plain Washer, 5/16"
AB	108386	Idler Pulley
AC	156131	Stud
AD	719002	Plain Washer, 5/16"
AE	717003	Full Lock Hex. Nut, 3/8"-16
AF	108418	Screw
AG	108416	Idler Lever Assembly
AJ	108472	Washer
AK	8171073	Races
AL	108322	Arbor Assembly with Bearings and Hardware