

Simplicity

**INSTRUCTIONS
AND PARTS LIST**

Mfgr's No. 206

8-12 DISC HARROW

**for
7 thru 10 H.P. Riding Tractors
and
Model W Tractor**

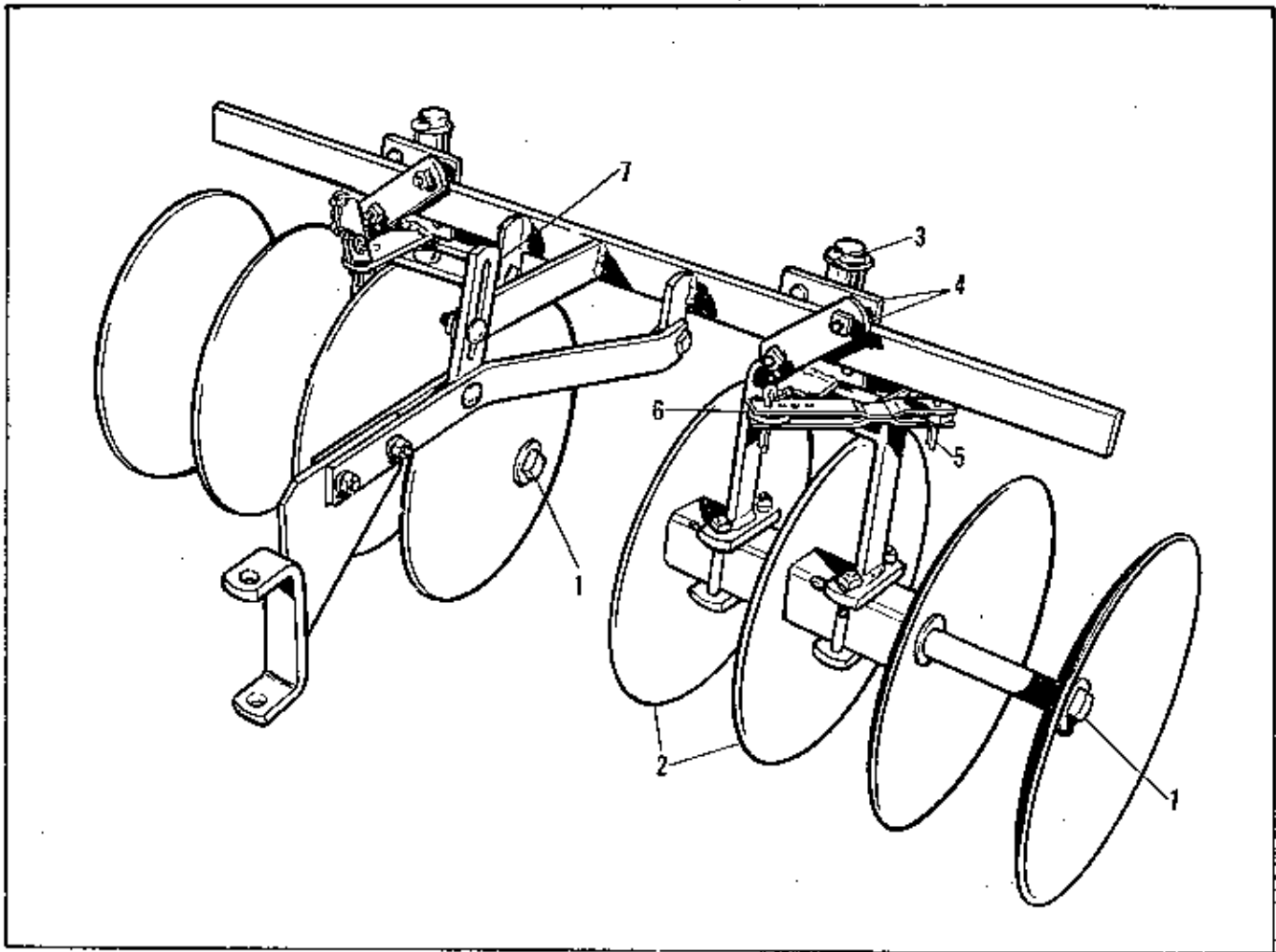

Fig. 1

PACKING

For ease in shipping, the disc harrow is packaged unassembled. Assemble the disc harrow by following the sequence of steps outlined below.

ASSEMBLY

1. Remove the gang bolts (1) from the frames and assemble the discs (2) into right hand and left hand gangs as shown in figure 1. Insert the gang bolts through the discs and wood bearings and secure in place with nuts and washers.
2. Clamp the disc gangs in place on the tool bar (3) using clamps (4), carriage bolts, hex nuts and lockwashers, as shown in figure 1.
3. The draw bar end assembly is fastened to the harrow draw bar by 2 carriage bolts through the upper set of holes in the draw bar end assembly, as shown in figure 2. Check to be sure that the upper set of holes are used when using the harrow on the Model 725.

OPERATION AND ADJUSTMENT

The disc gangs are reversible, and can be set to "throw in" or "throw out". To reverse discs, remove the cotter pin from the adjustment link (5), swing disc gang around half way, and replace cotter pin.

To angle the discs for greater or less penetration, remove the cotter pin and swing discs to desired angle and replace cotter pin in adjustment link. Set both gangs at the same angle.

The tilt adjustment arm (7) provides for changing the tilt of the disc gang. Raising the arm causes the outside disc to penetrate deeper than the inside ones, as is desirable when hilling. Tilting the adjustment arm also permits perfect leveling of the disc at any depth of penetration.

When disc harrowing with both gangs set to throw out, it is desirable to double disc by looping, to avoid leaving ridges.

Lubricate all bearings of the disc with an ordinary machine oil before each use.

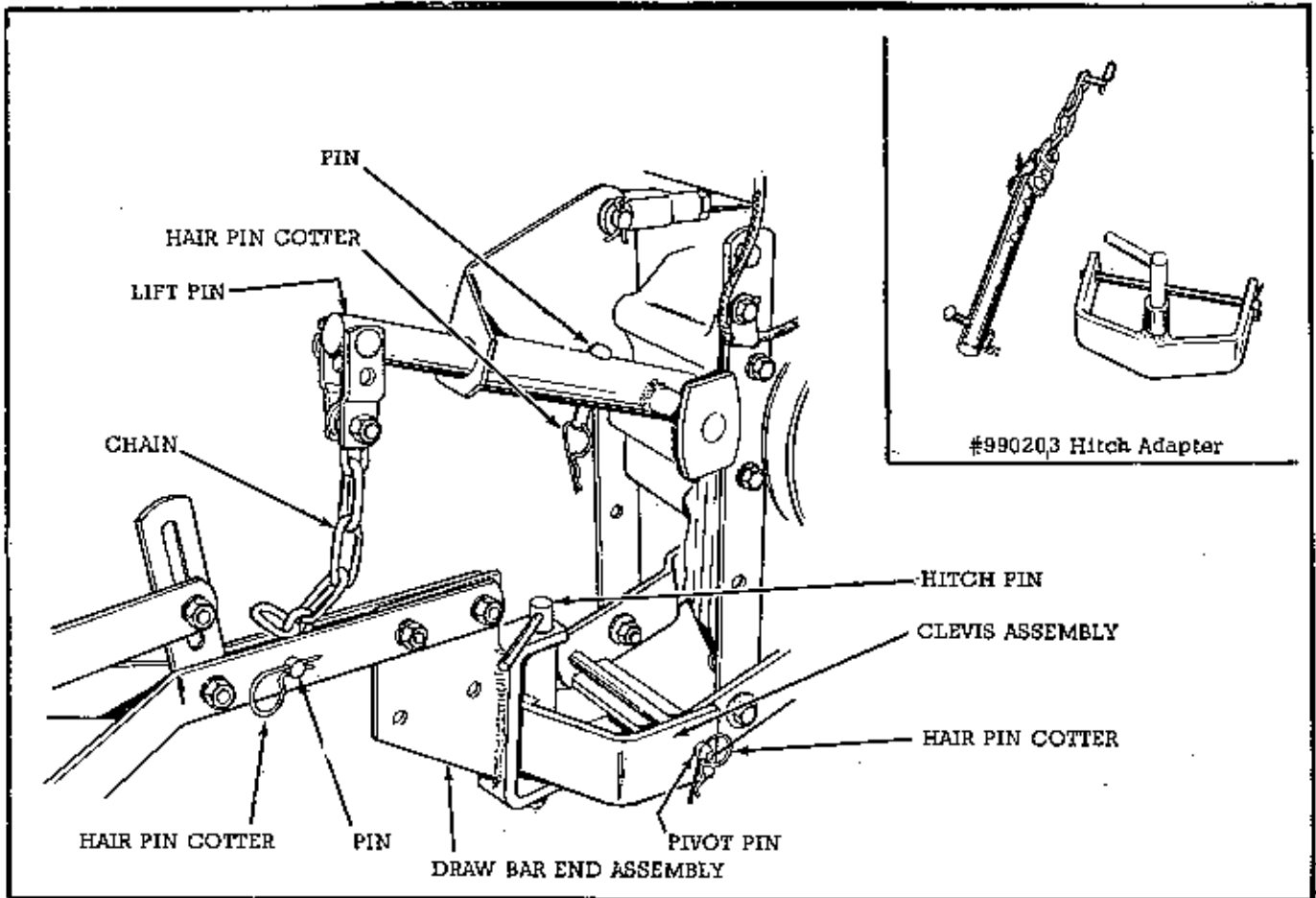

Fig. 2

ATTACHMENT

To attach the disc harrow to the riding tractors, it will first be necessary to attach the clevis assembly to the tractor tow assembly, using the pivot pin and hair pin cotters. See figure 2. Mount the lift pin in place in the tube of the tractor lift and fasten with pin and hair pin cotter.

Position the disc harrow in back of the tractor and attach the draw bar end assembly to the clevis assy. by inserting the hitch pin. Connect the lift chain to the harrow at point shown in figure 2, using pin and hair pin cotter.

Model "W"

Follow the instructions outlined for use with the riding tractors except for the variations listed below:

1. The hitch adapter kit No. 990203 is not required for use with the Model "W" Tractor.
2. The draw bar end assembly is repositioned so that the lower set of holes are used to fasten draw bar to draw bar end assembly.

8-12" DISC HARROW

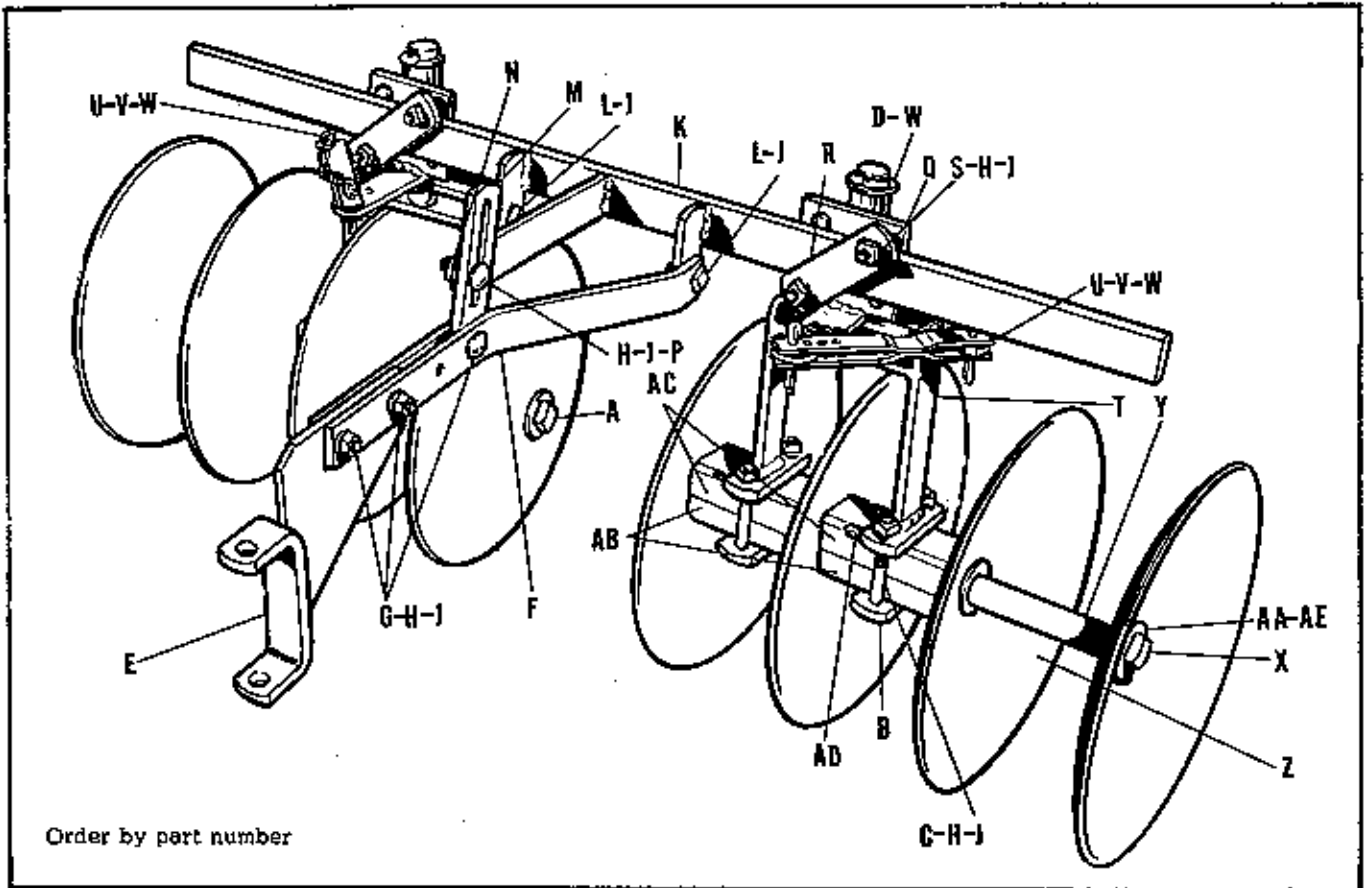

Order by part number

A	717004	Nut, Full Hex., 5/8-11 NC.
B	8281013	Clip, Bearing
C	702007	Bolt, Carriage, 3/8-16 NC x 3 1/4" lg.
D	8281014	Washer, Post
E	117011	Drawbar End
F	116002	Bar, Draw
G	702004	Bolt, Carriage, 3/8"-16 NC x 1 1/4" lg.
H	72002	Washer, Lock 3/8"
J	717003	Nut, Full Hex., 3/8"-16 NC
K	8283503	Bar Assembly, Cross
L	705005	Screw, Cap, Hex., 3/8"-16 NC x 1" lg.
M	8281024	Link, Tilt Adjusting
N	153073	Spacer
P	702002	Bolt, Carriage, 3/8"-16 NC x 1" lg.
Q	8282501	Clamp Assembly
R	8281008	Clamp, Clip
S	702006	Bolt, Carriage, 3/8"-16 NC x 1 3/4" lg.
T	8283502	Arch Assembly
U	8281501	Strap Assembly, Adjusting
V	116004	Chain
W	722013	Pin, Cotter
X	8281018	Axle
Y	8281016	Spacer, Disc.
Z	8281019	Blade, Disc, 12"
AA	116001	Washer, Special
AB	8281021	Block, Lower Bearing
AC	8281015	Block, Upper Bearing
AD	722012	Pin, Cotter, 3/16" x 3/4" lg.
AE	722005	Washer, Lock