

Attachment Illustrated Parts List



Attachment

Mfg. No.	Description
1695065	Catcher, Turbo Clean Sweep Triple

Simplicity

MANUFACTURING, INC.
500 N. Spring Street / PO Box 997
Port Washington, WI 53074-0997 USA

www.simplicitymfg.com

© Copyright 2007 Simplicity Manufacturing, Inc. All Rights Reserved. Printed In USA.

Part No.: 1734818

Rev. 04/2007

TP 400-4539-00-AT-SMA

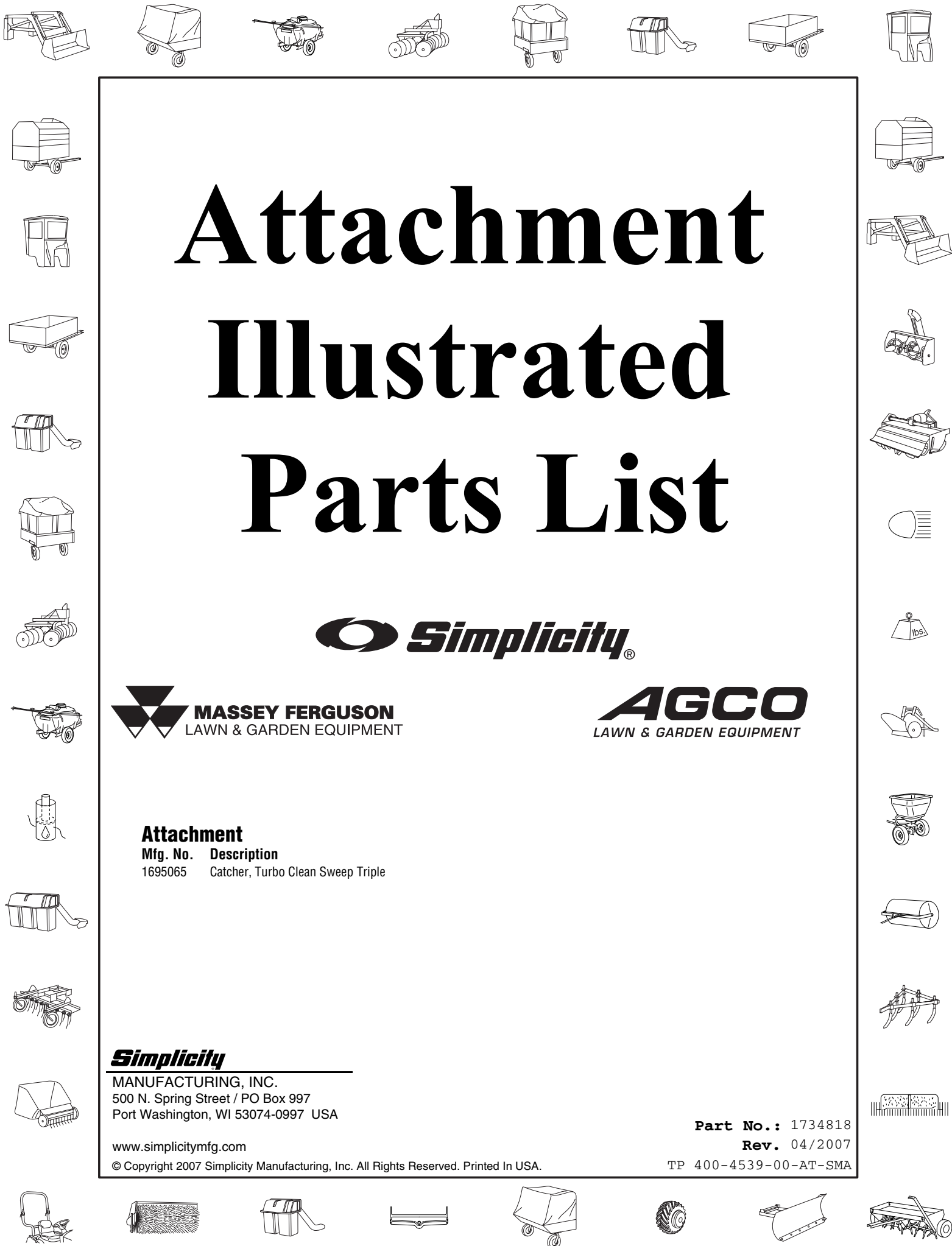

PRODUCT COMPONENTS	PAGES
Cover & Bag Group - Triple	4
Front Weight Carrier Group	6
Mount Group	8
Tube & Hitch Assembly	12
Torque Specification Chart	Inside Back Cover

Cover & Bag Group - Triple

986509

NOTE: Unless noted otherwise,
use the standard hardware torque
specification chart.

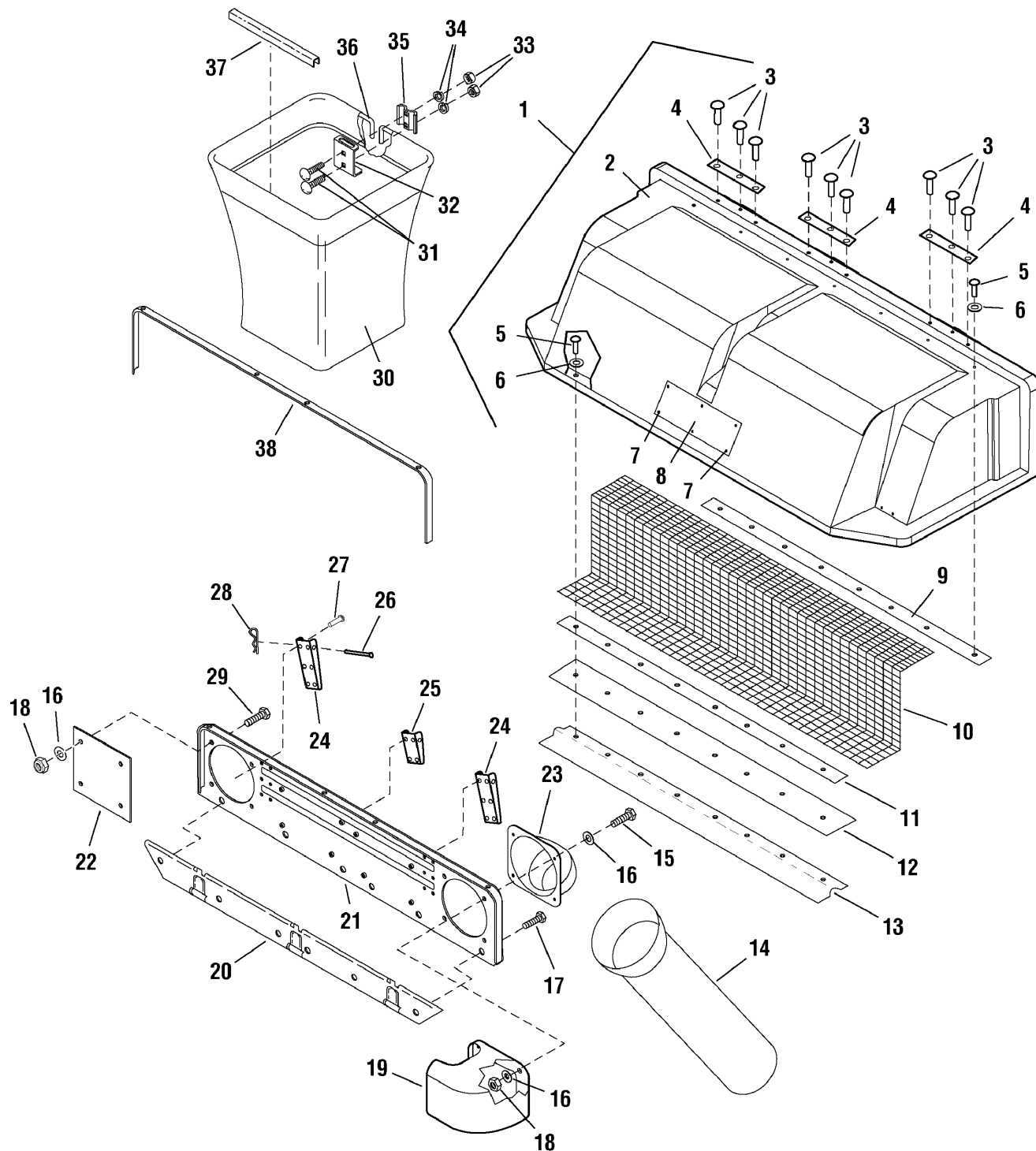

The above parts group applies to the following Mfg. Nos.:
1695065 - Catcher

Cover & Bag Group - Triple

REF NO	PART NO.	QTY.	DESCRIPTION
1	1717025SM	1	COVER & SCREEN ASSEMBLY, Grass Collector Complete (Incl. Ref. Nos. 2, 3, 4, 5, 6, 7, 8, 9, 10, 11, 12 & 13)
2	1717025SM	1	COVER, Grass Catcher Black Plastic
3	1960241SM	9	RIVET, Pop, .25OD .500L Steal,Steal Stem .50HD Black
4	1717067ASM	3	PLATE & TUBE ASSEMBLY, Hinge
5	2825160SM	25	RIVET, Pop, .188D .527L Steal,Steal Stem .37HD Dia.
6	1910531SM	16	WASHER, Rivet, .188 (0.20ID x 0.50OD x .05TH) Black
7	1667248SM	6	CLIP, Canoe .437LG .375DIA
8	1704405SM	1	DECAL, WARNING Do Not Open Cover
9	1716970ASM	1	CLAMP, Screen 16GA 40.0LG
10	1717041SM	1	SCREEN, Black Poly, 19.5 x 45.0
11	1717524SM	1	CLAMP, Seal, .060THK .75WD 48.00LG
12	1716968SM	1	SEAL, Black Rubber, .075 x 3.00 x 48.0
13	1716972ASM	1	ANGLE, Screen, 14GA 48"LG
14	1719807SM	1	CHUTE, Grass Collector Upper, 5.76ID 21.7L Scribed
15	1921333SM	4	CAPSCREW, Hex Head, 5/16-18 x 1 G5 Black
16	1919326SM	12	WASHER, 5/16 (0.34ID x 0.75OD x .06THK) Black
17	1925003SM	3	CAPSCREW, Hex Washer Head Taptite, 1/4-20 x 1/2 Black
18	1919438SM	8	NUT, Hex Lock ESNA Light, 5/16-18NC-3B Black
19	1717039SM	1	DEFLECTOR, Black Plastic Grass Collector
20	1716973ASM	1	CHANNEL & BRACKET ASSEMBLY, Support
21	1716966ASM	1	PLATE & BRACES ASSEMBLY, 3 Bag Grass Catcher
22	1725969SM	1	COVER, Inlet, .125THK 8.12 x 8.12 Plexiglass
23	1717038SM	1	DUCT, Inlet Black Plastic Grass Collector
24	1720875ASM	2	BRACKET, Hinge 3 Bag, 12GA 6.00LG with Point
25	1720945ASM	1	BRACKET, Hinge 3 Bag, 12GA 2.75LG
26	1672344SM	3	PIN, Round Head Drilled, 3/8 x 2-3/4 Black
27	1928707SM	16	RIVET, Pop, .188D .277L AL, AL Stem .37HD Black
28	1960074SM	3	CLIP, Hair Pin, .093DIA Spring Wire 1.625LG Black
29	1921332SM	4	CAPSCREW, Hex Head, 5/16-18 x 3/4 G5 Black
30	1703764SM	1	BAG, Grass, 15.4 x 16 x 22.5 White Poly Cloth
31	1931333SM	2	CARRIAGE BOLT, 5/16-18 x 3/4 G5 Black
32	1703807ASM	1	HANGER, Grass Bag Hoop
33	1917372SM	2	NUT, Hex 5/16-18 NC-2B Black
34	1917356SM	2	LOCKWASHER, Spring 3/8 Black
35	1672023ASM	1	CLAMP, Wire Diameter 1/2 (2), .344 Holes (3)
36	1703855ASM	1	HOOP, 1/2 ROD 16.12 x 16.75
37	1675707SM	1	EDGING, 13.50LG PVC Tube White
38	1717082SM	1	SEAL, Black Plastic 73"

Footnotes

The above parts group applies to the following Mfg. Nos.:

1695065 - Catcher

Front Weight Carrier Group

987366

NOTE: Unless noted otherwise,
use the standard hardware torque
specification chart.

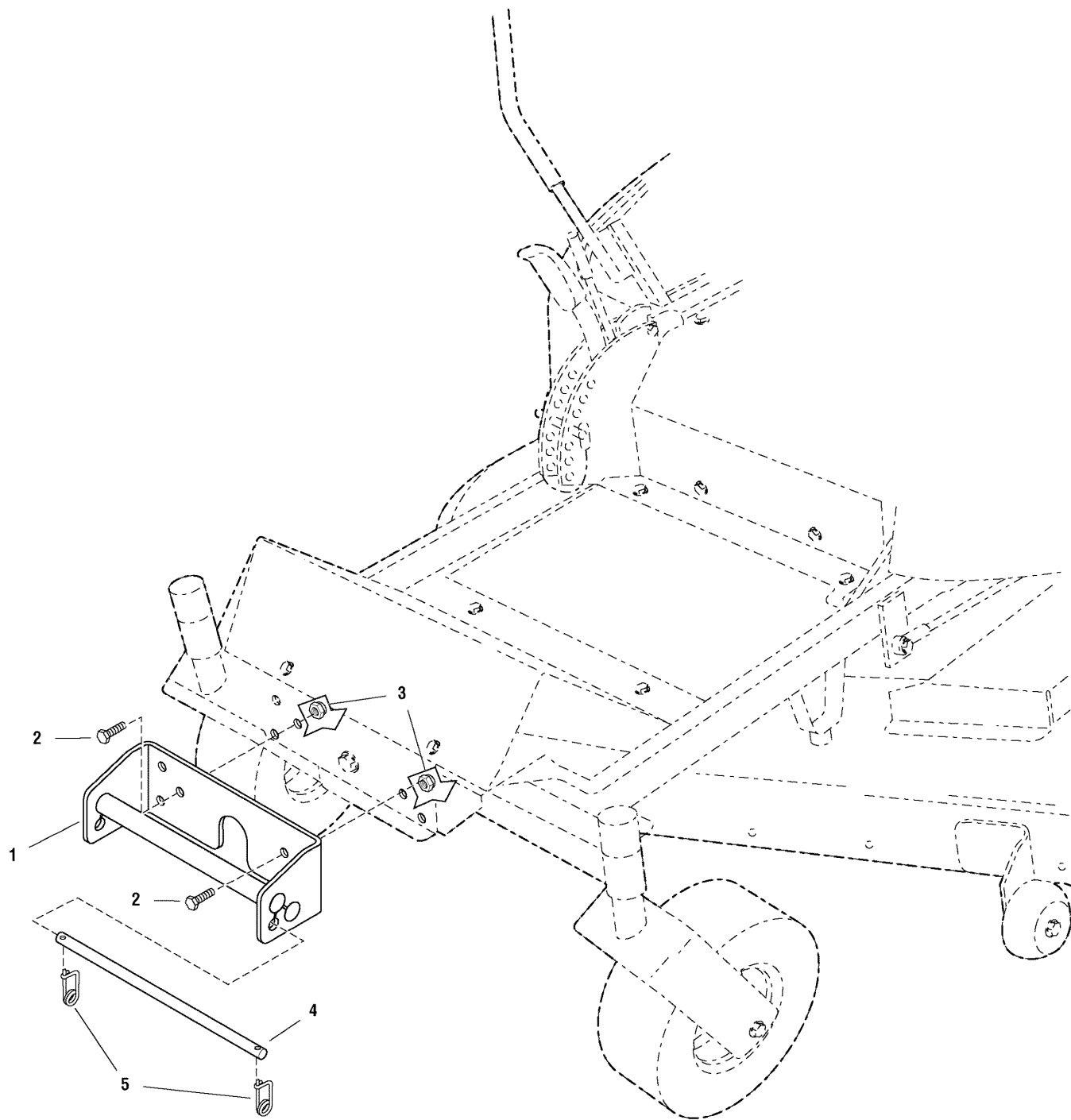

The above parts group applies to the following Mfg. Nos.:

1695065 - Catcher

Front Weight Carrier Group

REF NO	PART NO.	QTY.	DESCRIPTION
1	5049082ASM	1	HOLDER ASSEMBL, Weight
2	1921176SM	2	BOLT, 1/2-13 x 1-1/4
3	1960708SM	2	NUT, Hex Nylon Lock 1/2-13
4	5049143SM	1	ROD, Retaining, 1/2 x 13-3/4LG
5	2176012SM	2	RETAINER, Pin, Spring

Footnotes

The above parts group applies to the following Mfg. Nos.:

1695065 - Catcher

Mount Group

986508

NOTE: Unless noted otherwise, use the standard hardware torque specification chart.

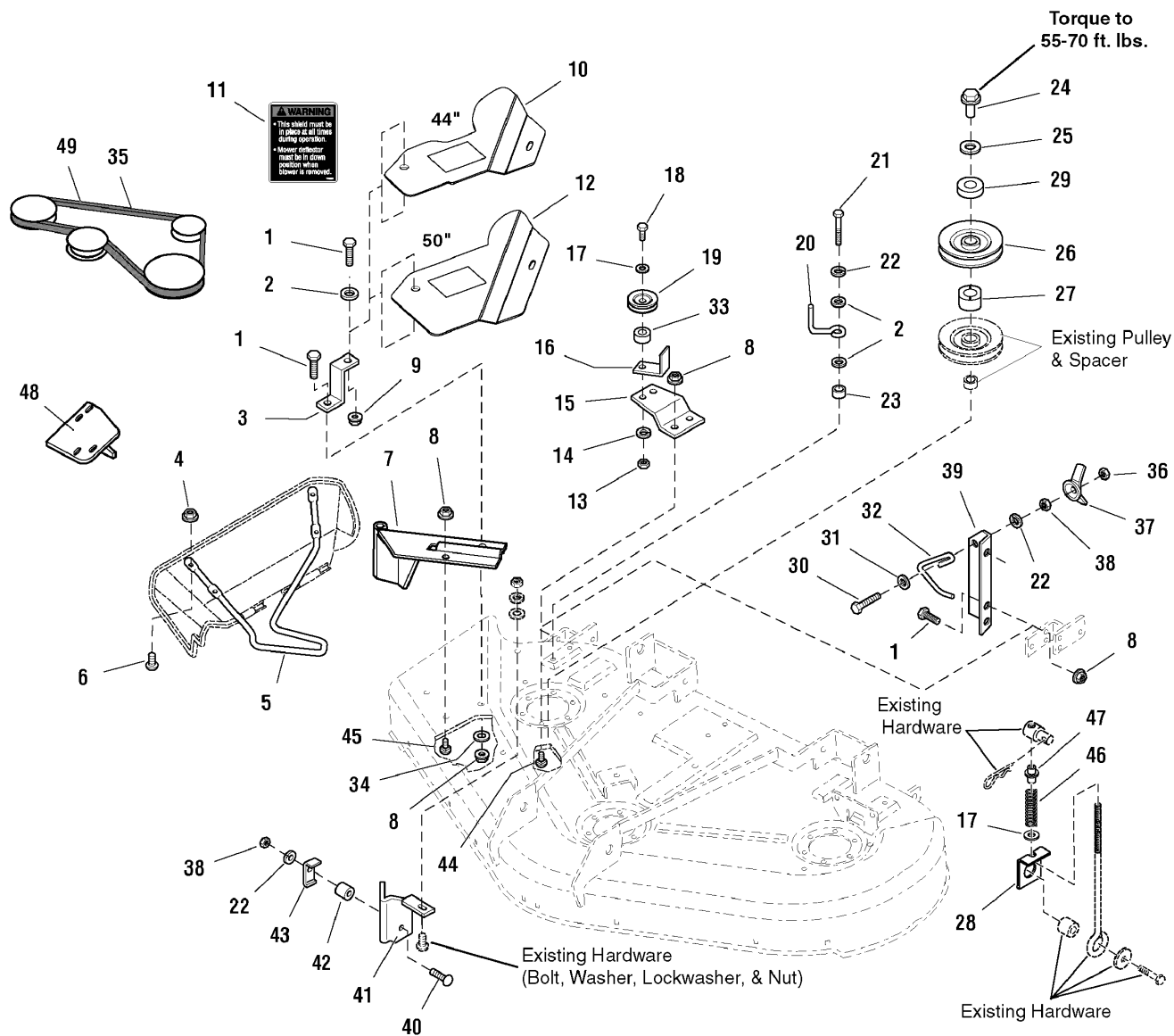

The above parts group applies to the following Mfg. Nos.:
 1695065 - Catcher

Mount Group

REF NO	PART NO.	QTY.	DESCRIPTION
1	1921333SM	4	CAPSCREW, Hex Head, 5/16-18 x 1 G5 Black
2	1919326SM	3	WASHER, 5/16 (0.34ID x 0.75OD x .06THK) Black
3	1718304ASM	1	SUPPORT, Belt Cover 10GA 1.0WD 3.0LG
4	1933896SM	4	NUT, Hex Lock, 10-24 with Nylon Insert NC3B Black
5	1718295ASM	1	ROD, .375DIA 22.0LG
6	1960404SM	4	SCREW, Truss Head Phillips, #10-24 x 3/4 Black
7	1722546ASM	1	PIVOT & BRACKETS ASSEMBLY, 38, 44 & 50"
8	1931277SM	6	NUT, Hex Flange Whiz Lock, 5/16-18 Small Black
9	1919438SM	1	NUT, Hex Lock ESNA Light, 5/16-18NC-3B Black
10	5049171ASM	1	COVER, Belt 44" 12GA
11	1717291SM	2	DECAL, WARNING Sheild & Mower Deflector
12	5049170ASM	1	COVER, Belt 50" 12GA
13	1916950SM	1	NUT, Hex 3/8-16 NC-2B Black
14	1916965SM	1	LOCKWASHER, Spring 3/8
15	1704768ASM	1	BRACKET, Z .164TH 5.88WD 3.21LG
16	1724373ASM	1	BRACKET, L 12GA 1.24WD 2.24LG 2.28LG
17	1924940SM	1	WASHER, 3/8 (0.41ID x 0.87OD x .08THK) Black
18	1923701SM	1	CAPSCREW, Hex Head, 3/8-16 x 2 G5 Black
19	1714817SM	1	PULLEY, Idler, 2.75OD 0.380ID 0.50W
20	2172845SM	1	STOP, Belt, .188WIRE 1.750,2.250 Black
21	1921221SM	1	CAPSCREW, Hex Head, 5/16-18 x 1-1/2 G5 Black
22	1917356SM	1	LOCKWASHER, Spring 5/16 Black
23	1710703SM	1	SPACER, 0.328ID x 0.499OD x 0.625LG Powdered Metal
24	1713523SM	1	NUT, Sleeve, 9/16-18 x 3/4INT x 1.34LG Black
25	1603592SM	1	WASHER, Bellville, 0.88ID x 1.75OD x .08TH Black
26	1709941SM	1	PULLEY, 04.30OD 1.000ID 0.579 Groove 9GA
27	1713623SM	1	HUB, .79ID x 1.5OD x .73LG Metafusion
28	5049145ASM	1	PLATE, Spring Support 10GA
29	5049088SM	1	SPACER, 0.812ID x 1.75OD x 0.50LG
30	1960318SM	1	CAPSCREW, Hex Head, 5/16-18 x 2-1/2 G5 Flat Black
31	1919381SM	1	WASHER, 5/16 (0.34ID x 1.00OD x .13THK) Black
32	1705064SM	1	SPRING, Latch, .125WIRE 4.3LG Black
33	2108717SM	1	SPACER, 0.390ID x 0.625OD x .265LG
34	1922755SM	1	WASHER, 3/8 (0.41ID x 1.00OD x .13THK) Black
35	1732945SM	1	V-BELT, 3L, 44" Mower Deck
36	1923362SM	1	NUTHex Centerlock, 5/16-18 Black
37	1679163SM	1	NUT & CUP ASSEMBLY, Wing, 5/16-18 E-Coat
38	1917372SM	2	NUT,Hex, 5/16-18 NC-2B Black
39	1704982ASM	1	PLATE, Anchor
40	1960223SM	1	CARRIAGE BOLT, 5/16-18 x 1-1/4 G5 Black
41	1704880ASM	1	BRACKET ASSEMBLY, Cutoff, 44"
42	1666294SM	1	SPACER, 0.385ID x 0.668OD x 0.455LG Powdered Metal Black
43	1705308ASM	1	BRACKET, L 12GA 1.00WD 1.98LG 0.62LG
44	1923325SM	2	CAPSCREW, Hex Head, 5/16-18 x 7/8 G5 Black

Footnotes

The above parts group applies to the following Mfg. Nos.:

1695065 - Catcher

Mount Group

986508

NOTE: Unless noted otherwise, use the standard hardware torque specification chart.

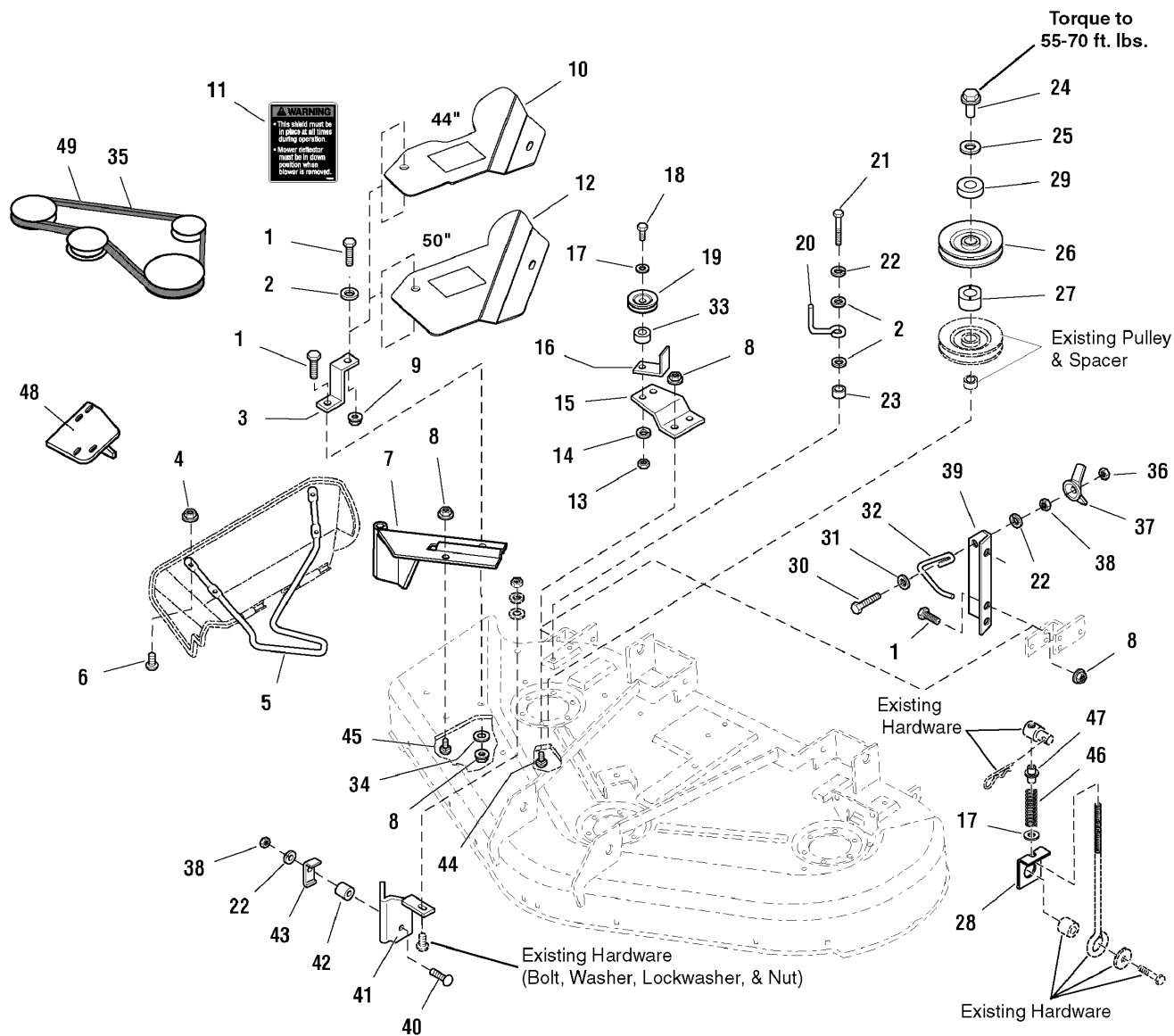

The above parts group applies to the following Mfg. Nos.:
 1695065 - Catcher

Mount Group

REF NO	PART NO.	QTY.	DESCRIPTION
48	1704983ASM	1	BRACKET & PLATE ASSEMBLY, Clamp
49	1707956SM	1	V-BELT, 3L, 50" Mower Deck

Footnotes

The above parts group applies to the following Mfg. Nos.:

1695065 - Catcher

Tube & Hitch Assembly

987365

NOTE: Unless noted otherwise,
use the standard hardware torque
specification chart.

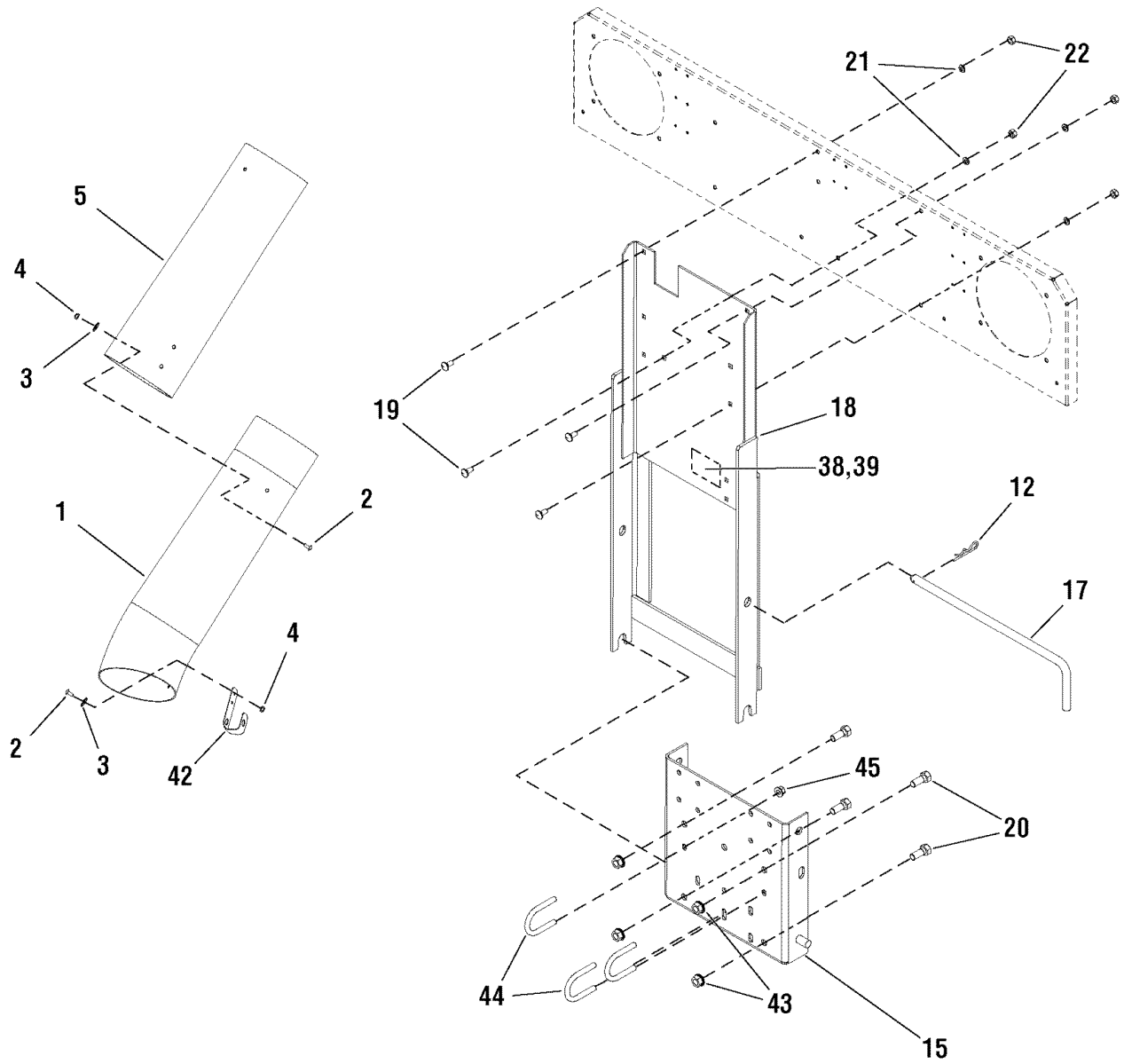

The above parts group applies to the following Mfg. Nos.:
1695065 - Catcher

Tube & Hitch Assembly

REF NO	PART NO.	QTY.	DESCRIPTION
1	5049152SM	1	LOWER TUBE
2	1960404SM	5	SCREW, Truss Head, #10 - 24 x 3/4
3	1960096SM	5	WASHER
4	1933896SM	5	NUT, Hex Nylock, #10 - 24
5	5049151SM	1	TUBE, Mid-Section
12	1960033SM	1	CLIP, Hairpin
15	1732625ASM	1	HITCH PLATE ASSEMBLY
17	1717085SM	1	HITCH ROD
18	1723437ASM	1	SUPPORT ASSEMBLY
19	1931335SM	4	BOLT, Carriage, 5/16 - 18 x 1
20	1921176SM	4	CAPSCREW, Hex Head, 1/2 - 13 x 1-1/4 (Used ONLY on models with Flat Bumpers)
21	1917356SM	4	LOCKWASHER, 5/16
22	1917372SM	4	NUT, Hex, 5/16 - 18
38	--	1	DECAL I.D. (Not serviceable)
39	--	1	OVERLAY, Mylar (Not serviceable)
42	1705063SM	1	CLIP, Spring
43	1960668SM	4	NUT, Hex Whiz Lock Flange, 1/2 - 13 (Used ONLY on models with Flat Bumpers)
44	1732617SM	3	U-BOLT, 3/8 x 1-1/4 (Used ONLY on models with Tube Bumpers)
45	1960687SM	6	NUT, Hex Flange, 3/8 - 16, ESNA (Used ONLY on models with Tube Bumpers)
46	1732613	1	OPERATORS MANUAL

Footnotes

The above parts group applies to the following Mfg. Nos.:

1695065 - Catcher

Hardware Identification & Torque Specifications

Common Hardware Types

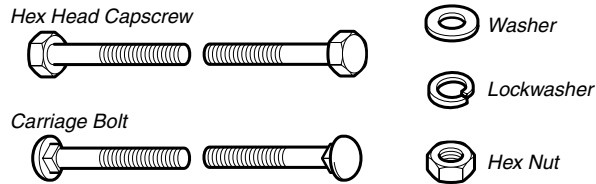

Standard Hardware Sizing

When a washer or nut is identified as **1/2"**, this is the *Nominal size*, meaning the *inside diameter* is 1/2 inch; if a second number is present it represent the *threads per inch*

When bolt or capscrew is identified as **1/2 - 16 x 2"**, this means the *Nominal size*, or *body diameter* is 1/2 inch; the second number represents the *threads per inch* (16 in this example, and the final number is the *body length* of the bolt or screw (in this example 2 inches long).

The guides and ruler furnished below are designed to help you select the appropriate hardware and tools.

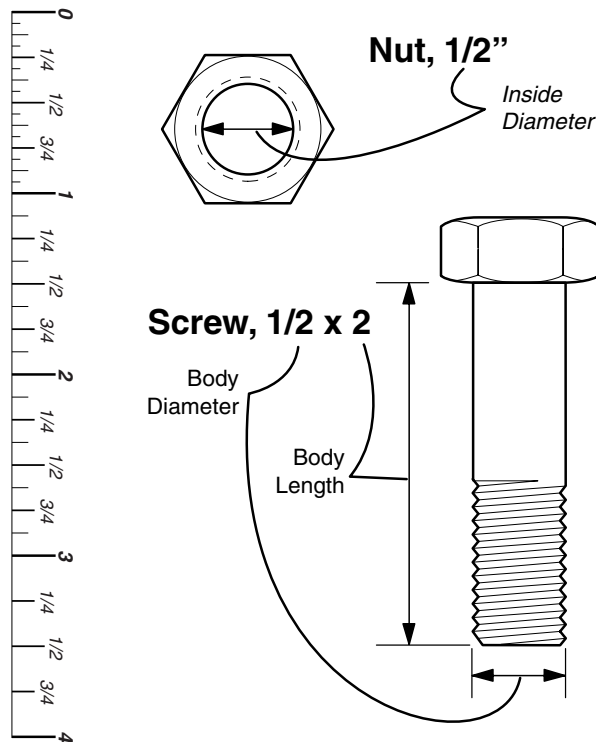

Torque Specification Chart						
FOR STANDARD MACHINE HARDWARE (Tolerance ± 20%)						
Hardware Grade	No Marks SAE Grade 2		SAE Grade 5		SAE Grade 8	
	in/lbs ft/lbs	Nm.	in/lbs ft/lbs	Nm.	in/lbs ft/lbs	Nm.
8-32	19	2.1	30	3.4	41	4.6
8-36	20	2.3	31	3.5	43	4.9
10-24	27	3.1	43	4.9	60	6.8
10-32	31	3.5	49	5.5	68	7.7
1/4-20	66	7.6	8	10.9	12	16.3
1/4-28	76	8.6	10	13.6	14	19.0
5/16-18	11	15.0	17	23.1	25	34.0
5/16-24	12	16.3	19	25.8	27	34.0
3/8-16	20	27.2	30	40.8	45	61.2
3/8-24	23	31.3	35	47.6	50	68.0
7/16-14	30	40.8	50	68.0	70	95.2
7/16-20	35	47.6	55	74.8	80	108.8
1/2-13	50	68.0	75	102.0	110	149.6
1/2-20	55	74.8	90	122.4	120	163.2
9/16-12	65	88.4	110	149.6	150	204.0
9/16-18	75	102.0	120	163.2	170	231.2
5/8-11	90	122.4	150	204.0	220	299.2
5/8-18	100	136	180	244.8	240	326.4
3/4-10	160	217.6	260	353.6	386	525.0
3/4-16	180	244.8	300	408.0	420	571.2
7/8-9	140	190.4	400	544.0	600	816.0
7/8-14	155	210.8	440	598.4	660	897.6
1-8	220	299.2	580	788.8	900	1,244.0
1-12	240	326.4	640	870.4	1,000	1,360.0

NOTES

- These torque values are to be used for all hardware excluding: locknuts, self-tapping screws, thread forming screws, sheet metal screws and socket head setscrews.
- Recommended seating torque values for locknuts:
 - for prevailing torque locknuts - use 65% of grade 5 torques.
 - for flange whizlock nuts and screws - use 135% of grade 5 torques.
- Unless otherwise noted on assembly drawings, all torque values must meet this specification.

Wrench & Fastener Size Guide



1/4" Bolt or Nut
Wrench—7/16"

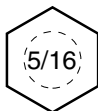

5/16" Bolt or Nut
Wrench—1/2"

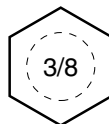

3/8" Bolt or Nut
Wrench—9/16"



7/16" Bolt or Nut
Wrench (Bolt)—5/8"
Wrench (Nut)—11/16"

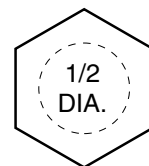

1/2" Bolt or Nut
Wrench—3/4"

