

6500 SERIES

Hydrostatic
Garden Tractor

12.5 HP Tractor
Mfg. No. 1691468

16 HP Tractor
Mfg. No. 1691263

17 HP Tractor
Mfg. No. 1691732

42" Mower
Mfg. No. 1691423

48" Mower
Mfg. No. 1691425
Mfg. No. 1691736



PARTS MANUAL

Product Identification:

When ordering parts, keep your products serial number and manufacturer's number in mind. Variations may occur in a part between early and later model products, causing the product serial number to be listed in the parts description whenever these variations occur.

Record your I.D. numbers here for quick, future reference.

Product Mfg. No. _____ S/N _____ Mower Mfg. No. _____ S/N _____

Attention:

Standard torques appear in a chart at the end of the manual, while important individual torques are given on specific parts drawings.

CRITICAL and MAJOR notations point out important facts or instructions which relate to personal safety and proper machine operation. Any CRITICAL notation **C** which may appear in this book, pinpoints characteristics which, if not properly followed, can create a safety hazard. Any MAJOR notation **M** which may appear in this book, marks characteristics which, if not properly followed, may result in operating failure, shortened product life, or greatly reduced quality of the unit.

For your convenience, assembly notes are included in parts drawings to assist in repair and assembly of unit.

NOTE: Specifications may change without notice.

SIMPLICITY PRODUCTS FOR THE PROPER CARE OF EQUIPMENT
These genuine *Simplicity* products will help the owner extend the life of his equipment.

OILS - SPECIFICALLY BLENDED OF HIGH QUALITY BASE OILS & ADDITIVES.

Special Worm Gear (Roticut) Oil for use in all tillers and snowthrowers with worm gear auger drive. Required for protection of brass gears and mating parts. **Case of 12 Quarts, Part #1685100, Individual Quarts 118065.**

Multi-Purpose Hydraulic/Transmission Oil for use in most hydraulic applications, and hydrostatic and gear transmissions. Specific *Simplicity* applications: All hydrostatic transmissions, all bevel gear cases, all Broadmoor, Landlord, Sovereign, 4000, 6000, 7000 transmissions (except Peerless Gear Transmissions). (Not used in SunStar tractor transmission.) **Case of 12 Quarts, Part #1685516, 2½ Gallon Container, Part #1685539.**

2-Cycle Engine Oil, a premium lubricant for all 2-cycle air-cooled engines. **Case of 12 Part #1685517.**

SAE 5W 30 SF/CD Cold Weather Engine Oil for use in all four cycle and diesel engines at 30° temp. and under. **Case of 12 Quarts, Part # 1685576.**

SAE 15W40 SF/CD Engine Oil for gas and diesel engines, warm weather; see engine manufacturer recommendations. **Case of 12 Quarts, Part #1685554.**

Grease Gun Kit has 12" flexible hose to get into tight spots with ease. Kit contains: gun and 1-8 oz. tube of grease, **Part #1685510.** For replacement tube, order **Part # 103077.**

Pneumatic Tire Seal, seals all leaks including bead leaks and punctures up to 3/16 inch diameters. Prevents flats for tread life of tire. Available in following amounts.

Case of 12 - 11 Oz. Tubes **1685537**
Case of 24 - 11 Oz. Tubes **1685525**
5 Gallon Pail **1685527**

Touch-Up Paint keeps equipment in showroom condition.

Spray Cans	Quarts	Daubbers 12/Ctn.
*Simplicity Orange - 103262 (12 cans/1685179)	1685037	1685520 - Mixed (6 Simp. Orange, 6 White)
**Classic Orange - 1685558 (12 cans/1685559)	1685560	1685562 - Mixed (6 Classic Orange, 6-White)
White 103049 (12 cans/1685178)	1685032	1685562 - Mixed (6-Classic Orange, 6-White) 1685520 - Mixed (6-Simp. Orange, 6-White)
Black - 1685551 (12 Cans/1685552)	N.A.	N.A.
*For 1977 thru early 1986 products. **For products produced after 12/1/85.		

Simplicity Designer Seat Covers are double stitched, easy care vinyl. Keeps new seats new, makes worn seats look new.

- Small Cover for 4000, 5000,
& 6100 Tractors **1685540**
- Large Cover for 6200, 7000 &
9000 Tractors **1685541**
- SunStar Seat Cover **1685577**

Extend Equipment Life - Use Only Genuine *Simplicity* Parts

Table of Contents

Page

FRAME GROUP	2
Frame, Axle Supports, Lift Levers, Drawbar Braces, Footrests, Mower Up-Stop, PTO Lever	
FRONT AXLE GROUP	6
Axle Assy., Spindles, Tie Rod, Support Assy., Bushings	
STEERING & FRONT WHEEL GROUP	8
Steering Shaft, Steering Wheel, Drag Link Assy., Ball Joint Assy., Front Wheels & Tires, Hub Caps	
ENGINE GROUP (Mfg. No. 1691263, 1691468)	10
Engine, Baffle, Pulley Assy., Muffler Extension, Oil Drain, Belt, Choke Cable	
ENGINE GROUP (Mfg. No. 1691732)	12
Engine, Baffle, Pulley Assy., Muffler Extension, Oil Drain, Belt, Choke Cable	
TRANSAXLE & REAR WHEEL GROUP	14
Transaxle, Hub Assy., Rear Wheels & Tires, Torque Arm, Braces, Control Arm Assy., Fan, Pulley	
EATON TRANSAXLE 850	
HOUSING GROUP	16
LEFT AXLE SUBASSEMBLY	18
RIGHT AXLE SUBASSEMBLY	20
SHIFT QUADRANT GROUP	22
Quadrant, Shift Panel, Ball Joint Assy., Speed Control Handle, Bracket Assy.	
HYDRO RESERVOIR GROUP	24
Reservoir, Cap, Clamp, Hoses	
BRAKE LEVER ASSEMBLY & RELEASE VALVE	26
Brake Lever Bracket Assy., Brake Clevis Bracket, Spring, Release Valve Lever, Hydro Release Lever	
BRAKE & CLUTCH GROUP	28
Brake Pedal, Idler Bracket, Belt Guide, Clutch Rod, Tension & Compression Springs	
ELECTRICAL GROUP	30
Battery, Holddown, Harness, Solenoid, DSI Module, Keys & Switch, Circuit Breaker	
HOOD, GRILLE & DASH GROUP	32
Dashboard (Top & Bottom), Fuel Tank, Hour Meter, Hood, Grille, Headlight Assy., Baffle	
SEAT & DECK GROUP	34
Seat, Springs, Supports, Latch Assy., Hinges	
42" & 48" MOWER HOUSING GROUP	36
Mower Deck, Deflector, Arbor Covers, Baffles, Stone Guard	
42" & 48" ARBOR GROUP	38
Pulleys, Housing, Shaft & Bearing Assy., Adaptor, Blades	
42" & 48" MOWER BRAKE GROUP	40
Brake Rod Assys., Springs, Brackets	
42" & 48" CLUTCH & SUPPORT GROUP	42
V-Belt, Support Assy., Clutch Lever Assy., Idler Support, Rod Guide Assy., Pivot Arm, Rocker Arm Assy., Brake Rod, Clutch Rod	
42" & 48" HEIGHT ADJUSTING & ROLLER GROUP	44
Control Lever, Lift Rod, Lift Chain, Mower Arm Assy., Quadrant Assy., Rollers, Clevis	
DECAL GROUP	46

Mount RH and LH transmission braces
at upper outside locations (see Transaxle Group).

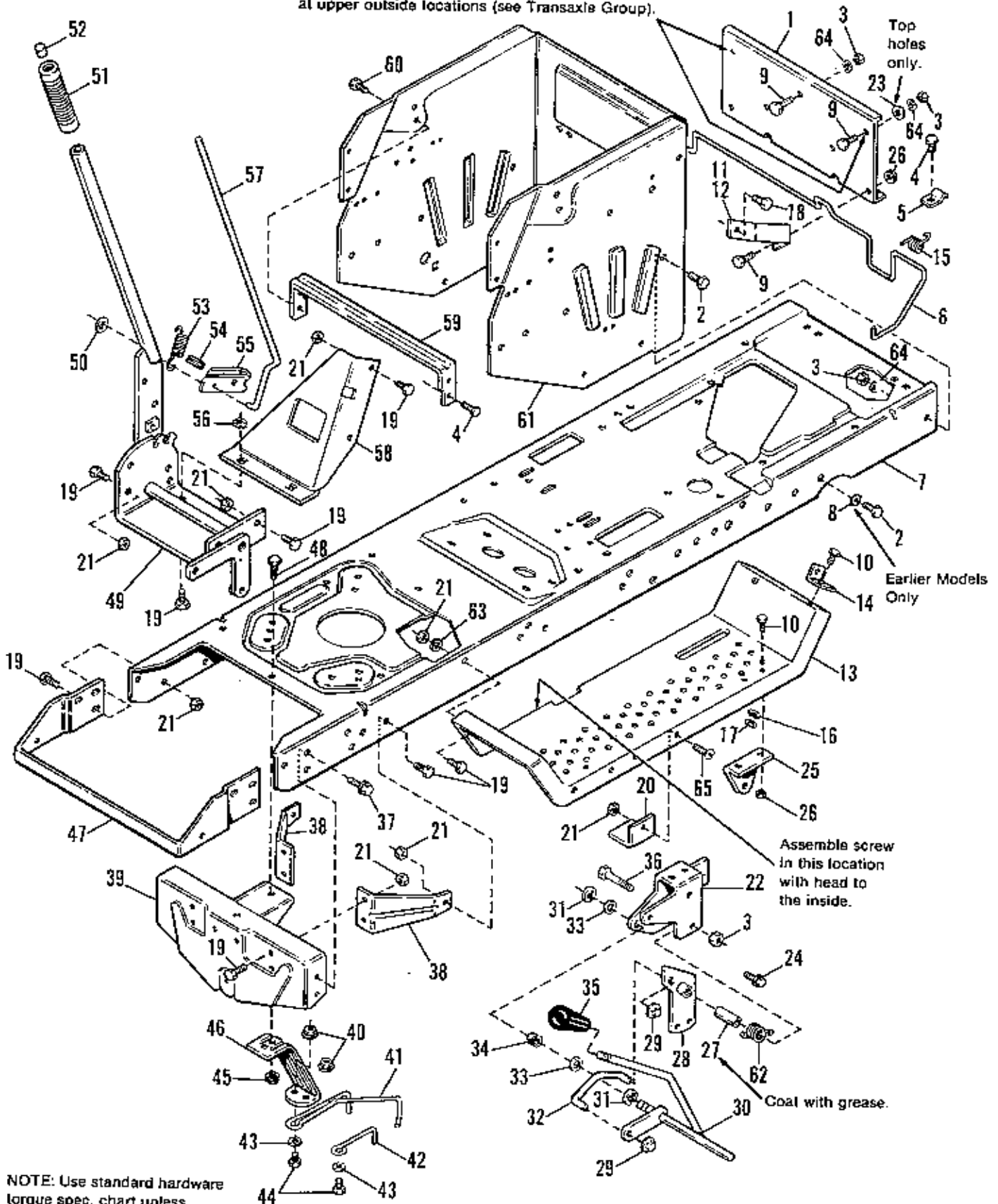

Ref. No.	Part No.	Qty.	Description
1	1679802	1	DRAWBAR
2	1921210	8	CAPSCREW, 3/8-16 x 1
3	1916950	10	NUT, Hex, 3/8-16
4	1924856	4	SCREW, Taptite, 5/16-18 x 1/2
5	1678388	2	CLIP
6	1701268	1	ROD, Seat Latch
7	1702626	1	FRAME
8	920427	1	LOCKWASHER, 3/8, Ext. Tooth (*Early Models Only)
9	1920415	3	CAPSCREW, 3/8-16 x 1-1/4"
10	1921959	3	CAPSCREW, 1/4-20 x 5/8
11	1701124	1	BRACE, Drawbar, L.H.
12	1701125	1	BRACE, Drawbar, R.H.
13	1679938	2	FOOTREST
14	1700670	1	BRACKET, Seat Latch
15	1701314	1	SPRING, Torsion
16	1917377	1	WASHER, Plain, 1/4 Std.
17	1916622	2	NUT, Hex, 1/4-20
18	1923683	2	SCREW, Taptite, 3/8-16 x 3/4
19	1921332	23	CAPSCREW, 5/16-18 x 3/4
20	1669168	2	UP-STOP, Mower
21	1917372	23	NUT, Hex, 5/16-18
22	1700677	1	BRACKET, PTO Lever Mtg.
23	931942	3	PUSHNUT
24	1925003	2	SCREW, Taptite, 1/4-20 x 1/2
25	1654783	1	SUPPORT, PTO Lever
26	1928352	2	NUT, Hex, Whiz Flange, 3/8-16
27	1669105	1	SPACER
28	1701431	1	ARM ASSY, PTO Link
29	1960093	2	NUT, Pal, 3/8
30	1702437	1	LEVER ASSY., PTO
31	158399	2	RING, Snap
32	1701434	1	LINK, PTO
33	1960206	2	WASHER

Ref. Nos. 34 thru 65 found on next page.

*Used on Models with electrical system grounded to frame.

Mount RH and LH transmission braces
at upper outside locations (see Transaxle Group).

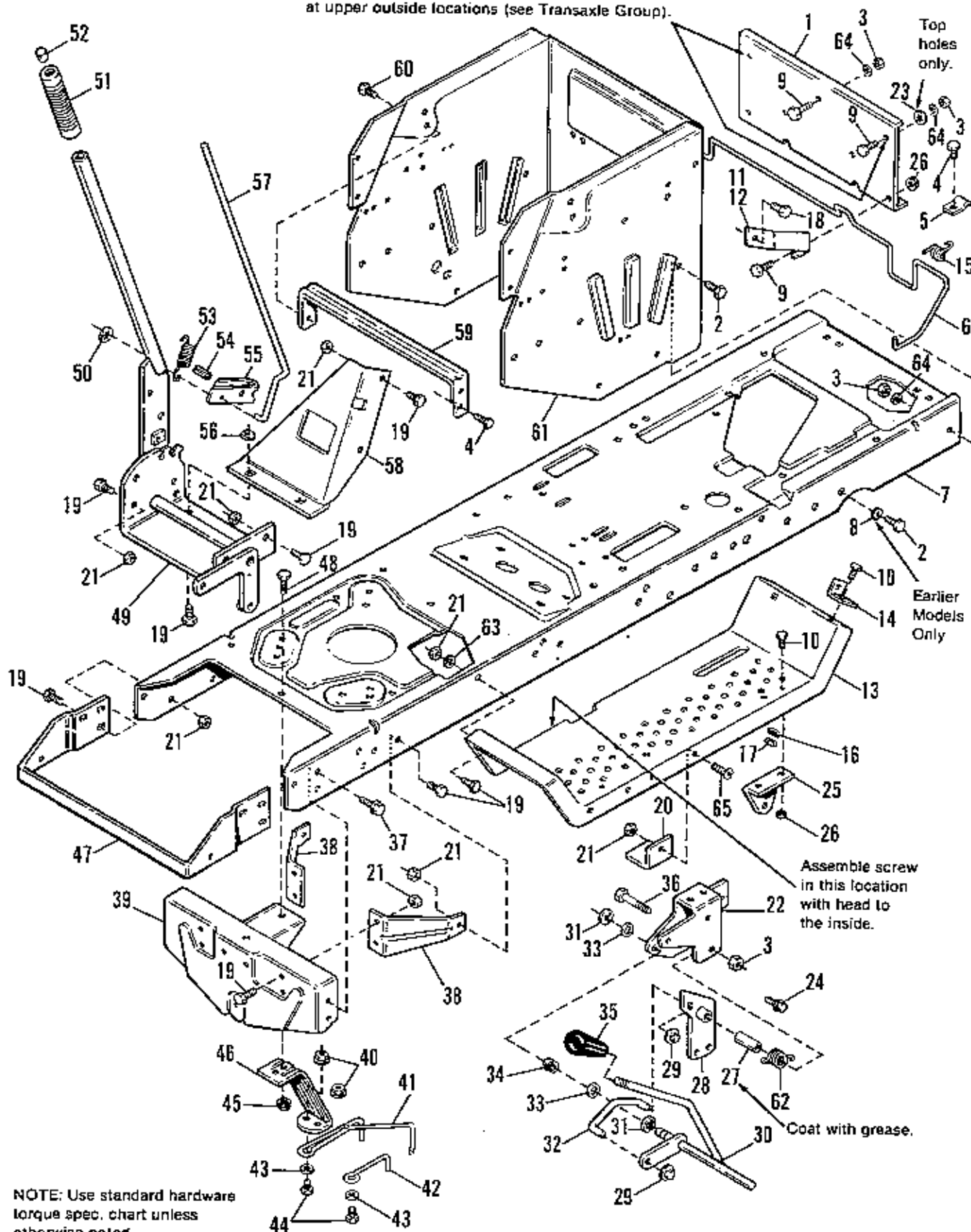

Frame Group

Ref. No.	Part No.	Qty.	Description
34	1669197	1	BUSHING, Split (Nylon)
35	172038	1	KNOB
36	1922130	1	CAPSCREW, 3/8-16 x 2-1/4
37	1664847	4	SCREW, Taptite, 5/16-18 x 3/4
38	1655076	2	BRACE, Axle Support
39	1663855	1	SUPPORT ASSY., Axle
40	1935048	2	NUT, Hex, Flange Lock, 5/16-18
41	1672118	1	STOP, Belt
42	1665812	1	STOP, Belt
43	1917377	2	WASHER, Plain, 1/4 Std.
44	1923325	2	CAPSCREW, 5/16-18 x 7/8
45	1927557	1	NUT, Whiz Flange, 5/16-18
46	1669169	1	SUPPORT, Belt Guide
47	1666954	1	SUPPORT, Hood
48	1930595	1	CAPSCREW, Whiz Flange, 5/16-18 x 1-1/4
49	1667295	1	LEVER ASSY., Lift
50	934953	1	NUT, Push On
51	156209	1	GRIP
52	1650157	1	BUTTON
53	1667286	1	SPRING
54	1927609	1	PIN, Spring, 3/8 x 1
55	1657648	1	LATCH, Lift Lever
56	916159	1	NUT, Speed, 5/16-18
57	1667290	1	ROD, Latch
58	1701223	1	BRACE, Lift Lever
59	1654707	1	BRACE, Seat (Wrapper)
60	1927477	2	SCREW, Taptite, 5/16-18 x 1
61	1702627	1	SUPPORT, Axle (Wrapper)
62	1701429	1	SPRING, Torsion
63	1917356	8	LOCKWASHER, 5/16
64	1916965	9	LOCKWASHER, 3/8
65	1918249	2	SCREW, Slotted, 5/16-18 x 3/4

Ref. Nos. 1 thru 33 found on preceding page.

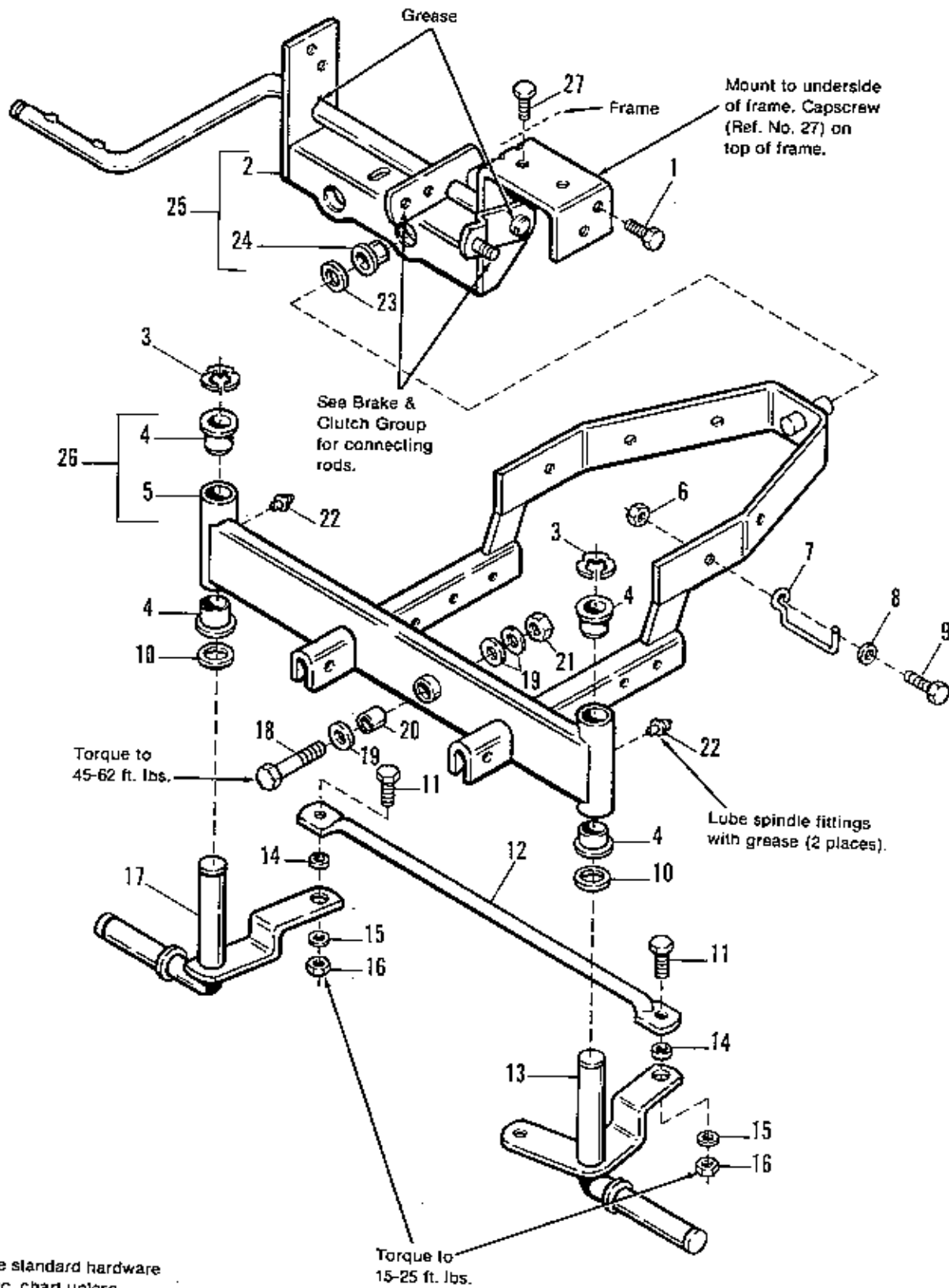

NOTE: Use standard hardware torque spec. chart unless otherwise noted.

Ref. No.	Part No.	Qty.	Description
1	1664847	4	SCREW, Taptite, 5/16-18 x 3/4
2		1	SUPPORT (See Ref. No. 25)
3	1611710	2	CLIP, Ring, 3/4
4	176440	4	BUSHING
5		1	AXLE ASSY., Front (See Ref. No. 26)
6	1917372	1	NUT, Hex, 5/16-18
7	1668147	1	GUIDE, Drag Link
8	1917642	1	WASHER
9	1921333	1	CAPSCREW, Hex Hd., 5/16-18 x 1
10	1960114	2	WASHER
11	1921210	2	CAPSCREW, Hex Hd., 3/8-16 x 1
12	1611715	1	TIE ROD
13	1677133	1	SPINDLE ASSY., L.H.
14	1611705	2	SPACER
15	1924940	2	WASHER
16	1930651	2	NUT, Hex, Lock, 3/8-16
17	1677131	1	SPINDLE ASSY., R.H.
18	1927469	1	CAPSCREW, Hex Hd., 1/2-13 x 2-1/4, Gr. 8
19	1926192	3	WASHER
20	1668662	1	SPACER
21	1930648	1	NUT, Hex Lock, 1/2-13
22	921133	2	FITTING, Grease
23	1919387	1	WASHER
24	1663114	1	BUSHING
25	1702394	1	SUPPORT ASSY., Brake/Clutch (Incl. Ref. Nos. 2 & 24)
26	1611707	1	AXLE ASSY., Front (Incl. Ref. Nos. 4 & 5)
27	1928729	1	CAPSCREW, 5/16-18 x 3/8

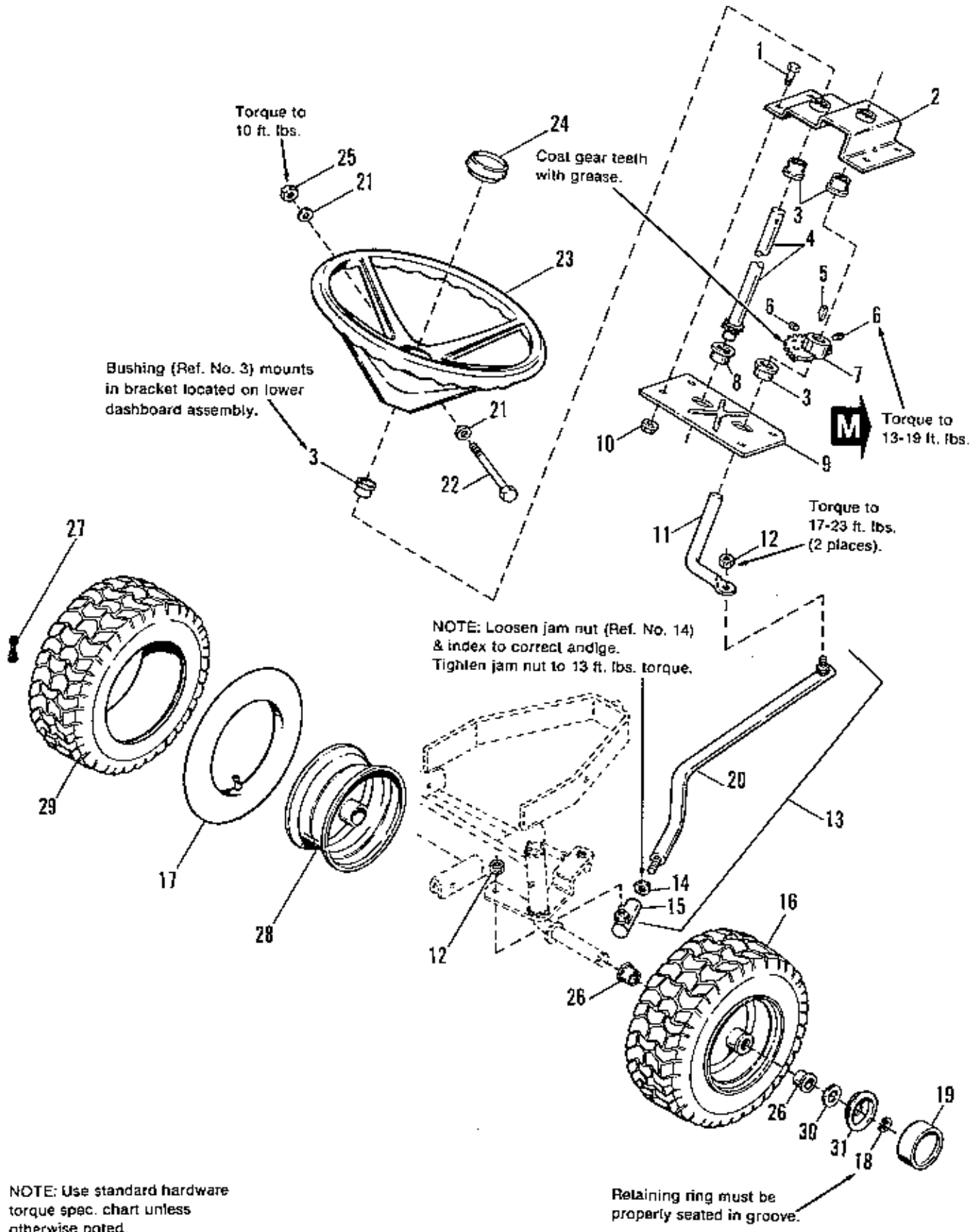

Ref. No.	Part No.	Qty.	Description
1	1921332	4	CAPSCREW, Hex Hd., 5/16-18 x 3/4
2	1667513	1	PLATE, Steering
3	176440	3	BUSHING
4	1701266	1	SHAFT ASSY., Steering
5	1667622	1	KEY
6	1928721	2	SETSCREW, 5/16-18 x 1/2
7	1675388	1	STEERING GEAR
8	1671737	1	BUSHING
9	1652743	1	BASE PLATE, Steering
10	1935048	4	NUT, Hex, Flange, 2 Way Lock, 5/16-18
11	1674076	1	ROD, Steering
12	1668927	2	NUT, Special
13	1674144	1	LINK ASSY., Drag (Incl. Ref. Nos. 14, 15 & 20)
14	1918403	1	NUT, Jam, 3/8-14
15	1669567	1	BALL JOINT ASSY.
16	1653617	2	WHEEL & TIE ASSY., 15 x 6-6 (Incl. Ref. Nos. 17, 26, 27, 28 & 29)
17	1664090	2	TUBE, 4.10 x 3.50-6 (Service Only)
18	1611710	2	KLIP RING, External, 3/4
19	1676519	2	HUB CAP
20		1	DRAG LINK (Order Ref. No. 13)
21	1919326	2	WASHER, Plain, 5/16
22	1925690	1	BOLT, Hex, 5/16-18 x 3-1/2
23	1701197	1	WHEEL, Steering
24	1657017	1	CAP, Steering Wheel
25	1923362	1	NUT, Hex, Lock, 5/16-18
26	156316	4	BEARING
27	172353	2	VALVE STEM
28	1653615	2	WHEEL
29	1653618	2	TIRE (Carlisle) 15 x 6.00-6
30	960160	2	WASHER
31	1701435	2	RETAINER, Hub Cap

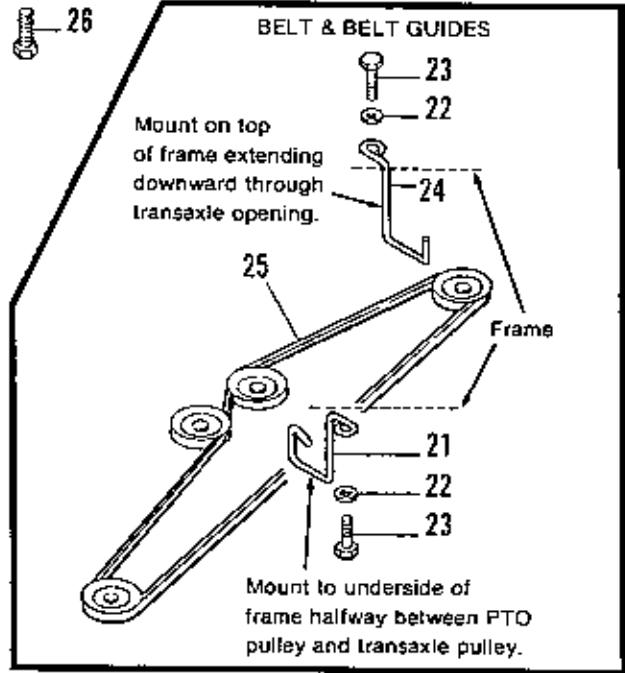
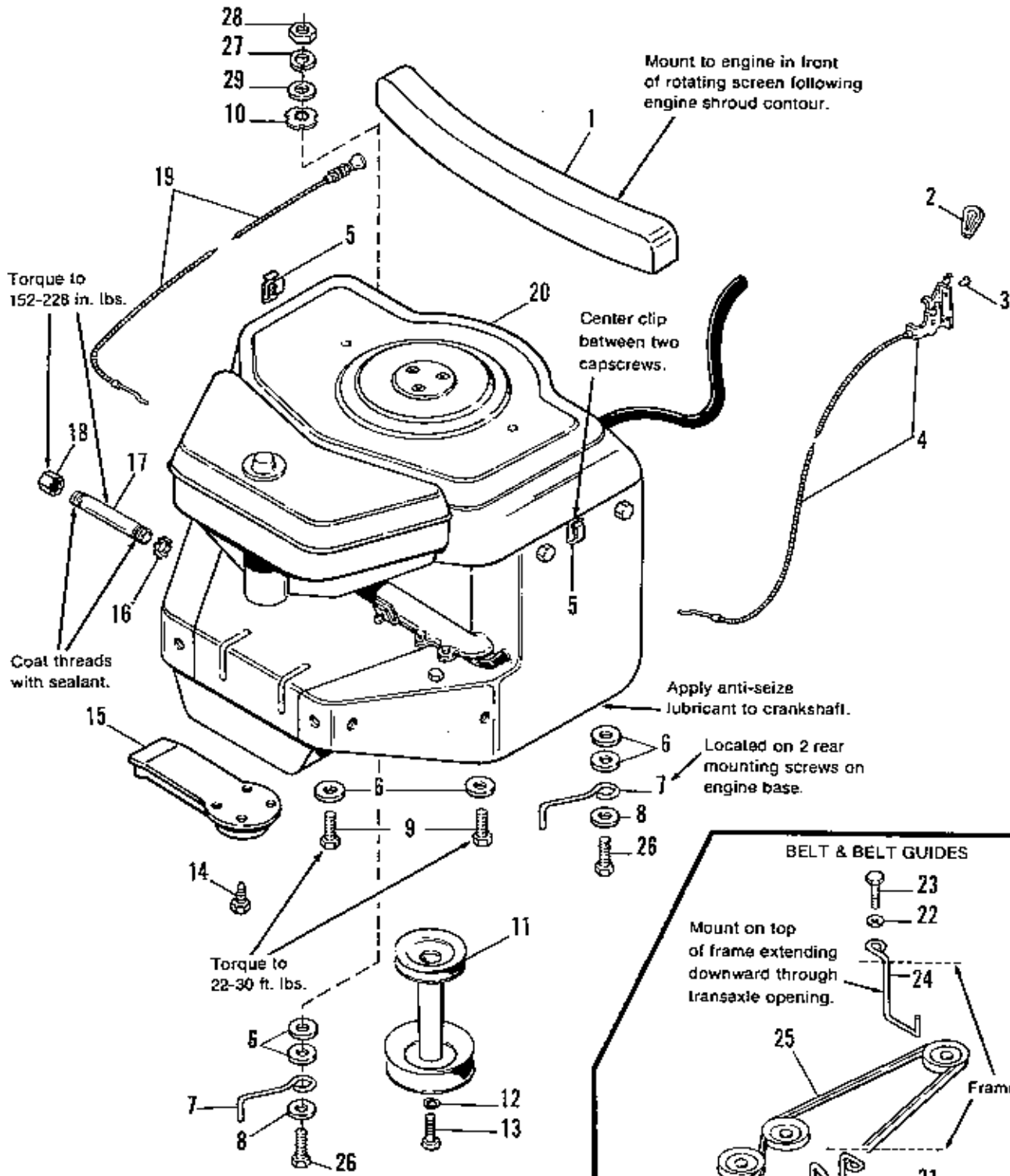

NOTE: Use standard hardware torque spec. chart unless otherwise noted.

Ref. No.	Part No.	Qty.	Description
1	1665752	1	BAFFLE, Engine Rear
2	1669147	1	KNOB, Throttle
3	960241	2	RIVET
4	1668047	1	CONTROL ASSY., Throttle
5	1701508	2	CLIP
6	1924356	6	WASHER, 3/8
7	1669640	2	BELT Stop
8	1917378	2	WASHER, 3/8
9	1930598	2	SCREW, Taptite, 3/8-16 x 1-1/2
10	920427	1	LOCKWASHER, Pyramidal Type, 3/8
11	1700782	1	PULLEY ASSY., Engine
12	1918199	1	LOCKWASHER, 7/16
13	1928038	1	CAPSCREW, Hex, 5/16-20 x 1-1/4
14	1934940	4	SCREW, Hex, Thd. Cutting, #8-32 x 3/8
15	1666787	1	EXTENSION ASSY., Muffler
16	1932849	1	LOCKNUT, Conduit
17	1670680	1	OIL DRAIN
18	1667346	1	CAP, Pipe
19	1667748	1	CABLE, Choke
20		1	ENGINE ASSY., Briggs & Stratton 12.5 HP
		1	ENGINE ASSY., Briggs & Stratton 16 HP
21	1701294	1	GUIDE, Belt
22	1917642	2	WASHER
23	1930601	2	SCREW, Taptite, 5/16-18 x 5/8
24	1702402	1	GUIDE, Belt
25	1656960	1	BELT, "V", Transmission Drive
26	960358	2	SCREW, Taptite, 3/8-16 x 2-1/2
27	916965	1	LOCKWASHER, 3/8 (Zinc Pltd.)
28	916950	1	NUT, Hex, Full, 3/8-16 (Zinc Pltd.)
29	917378	1	WASHER, 3/8 (Zinc Pltd.)

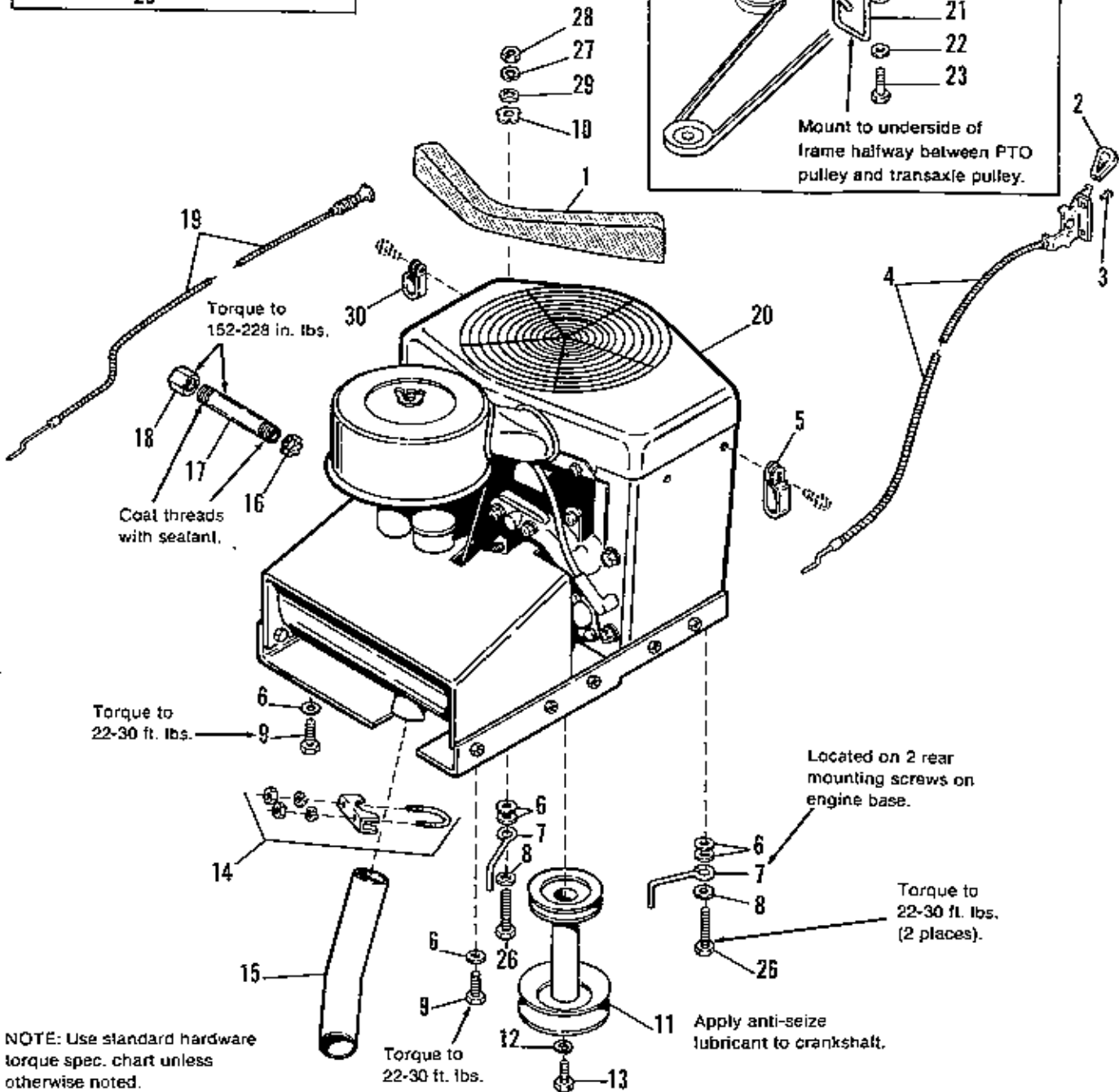
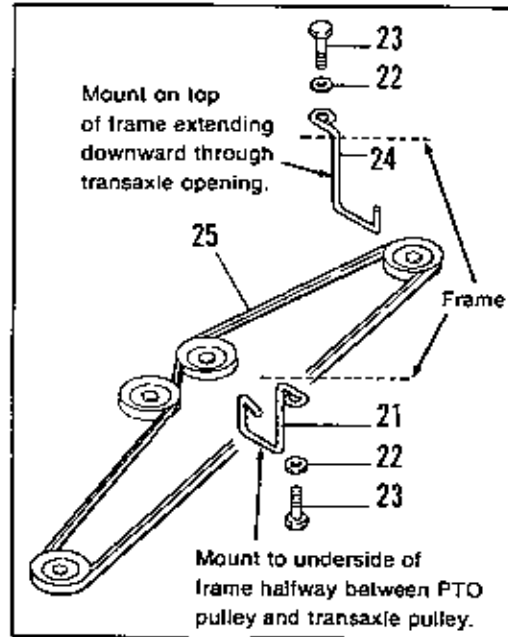
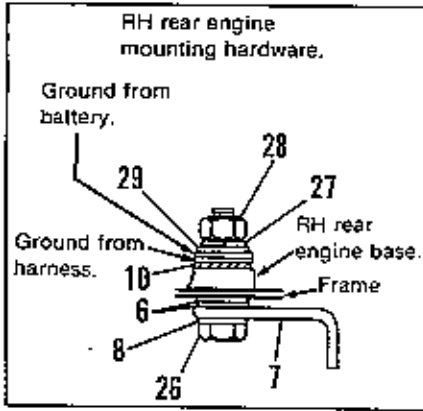

NOTE: Use standard hardware torque spec. chart unless otherwise noted.

Ref. No.	Part No.	Qty.	Description
1	1702843	1	BAFFLE, Engine, Top
2	1669147	1	KNOB, Throttle
3	960241	2	RIVET
4	1702836	1	CONTROL ASSY., Throttle
5	1676527	2	CLAMP, Cable
6	1924356	6	WASHER, 3/8
7	1669640	2	BELT Stop
8	1917378	2	WASHER, 3/8
9	1930598	2	SCREW, Taptite, 3/8-16 x 1-1/2
10	920427	1	LOCKWASHER, Pyramidal Type, 3/8
11	1700782	1	PULLEY ASSY., Engine
12	1918199	1	LOCKWASHER, 7/16
13	1928038	1	CAPSCREW, Hex, 5/16-20 x 1-1/4
14	935040	1	CLAMP, 1-1/2 Dia.
15	1702831	1	EXTENSION, Muffler
16	1932849	1	LOCKNUT, Conduit
17	1670680	1	OIL DRAIN
18	1667346	1	CAP, Pipe
19	1667748	1	CABLE, Choke
20		1	ENGINE ASSY., Kohler 17 HP
21	1701294	1	GUIDE, Belt
22	1917642	2	WASHER
23	1930601	2	SCREW, Taptite, 5/16-18 x 5/8
24	1702402	1	GUIDE, Belt
25	1656960	1	BELT, "V", Transmission Drive
26	960358	2	SCREW, Taptite, 3/8-16 x 2-1/2
27	916965	1	LOCKWASHER, 3/8 (Zinc Pltd.)
28	916950	1	NUT, Hex, Full, 3/8-16 (Zinc Pltd.)
29	917378	1	WASHER, 3/8 (Zinc Pltd.)
30	1703458	2	CLAMP, Cable

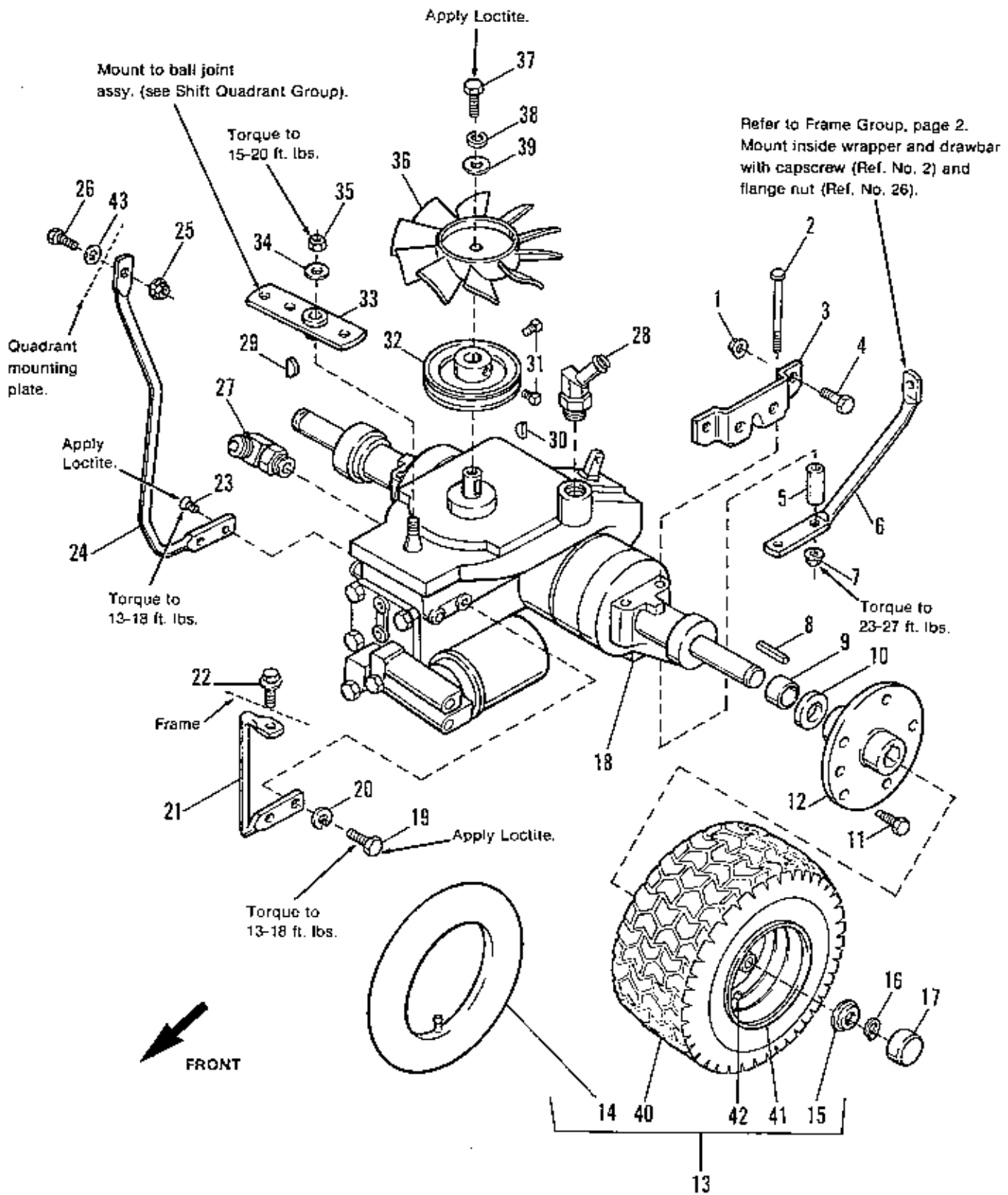

NOTE: Use standard hardware torque spec. chart unless otherwise noted.

Ref. No.	Part No.	Qty.	Description
1	1928352	4	NUT, Hex Flange, Whiz Lock, 3/8-16
2	1922648	4	CAPSCREW, 3/8-16 x 4
3	1679894	2	BRACKET, Transaxle Mounting
4	1921210	4	CAPSCREW, 3/8-16 x 1
5	1679740	4	SPACER, 1-1/4
6	1702630	1	BRACE, Transaxle, Rear, R.H. (Not Shown)
	1702631	1	BRACE, Transaxle, Rear, L.H.
7	1930645	4	NUT, Hex, Two-Way Lock, 3/8-16
8	905100	2	KEY, Straight
9	1701873	2	SPACER, Wheel
10	1927241	2	WASHER
11	8261100	10	BOLT, Wheel
12	1700620	2	HUB ASSY., Rear Wheel (Standard)
	1701914	1	HUB ASSY., Right Rear Wheel - 4" Offset used with Electric Lift Kit
13	173432	2	TIRE & WHEEL ASSY., 23 x 10.50 x 12
14	157638	2	TUBE
15	1676520	2	RETAINER, Hub Cap
16	932577	2	RETAINING RING
17	1676519	2	HUB CAP
18	1701203	1	TRANSAXLE (See pages 16 thru 21 for breakdown.)
19	1921332	2	CAPSCREW, 5/16-18 x 3/4
20	1917356	2	LOCKWASHER
21	1679667	1	TORQUE ARM
22	1930601	1	SCREW, Taptite, 5/16-18 x 5/8
23	1960344	2	SCREW, 5/16-18 x 3/4
24	1702629	1	BRACE, Transaxle, RH
25	1927557	1	NUT, Whiz Flange, 5/16-18
26	1921333	1	CAPSCREW, 5/16-18 x 1
27	1700446	1	FITTING, Hydro
28	1671228	1	FITTING, Hydro
29	905119	1	KEY, Woodruff (#3)
30	930672	1	KEY, Hi-Pro
31	1960110	2	SET SCREW, 1/4-28 x 1/2
32	1679501	1	PULLEY
33	1679737	1	CONTROL ARM ASSY. (Speed)
34	1917378	1	WASHER
35	1930651	1	NUT, Hex, Center-Lock, 3/8-16
36	1700021	1	FAN, 10-Blade (C.C.W.)
37	1923341	1	CAPSCREW, 1/4-20 x 3/4
38	1916964	1	LOCKWASHER
39	1960151	1	WASHER
40	1605967	2	TIRE, 23 x 10.50-12
41	173430	2	WHEEL
42	172353	2	VALVE STEM
43	1917642	1	WASHER

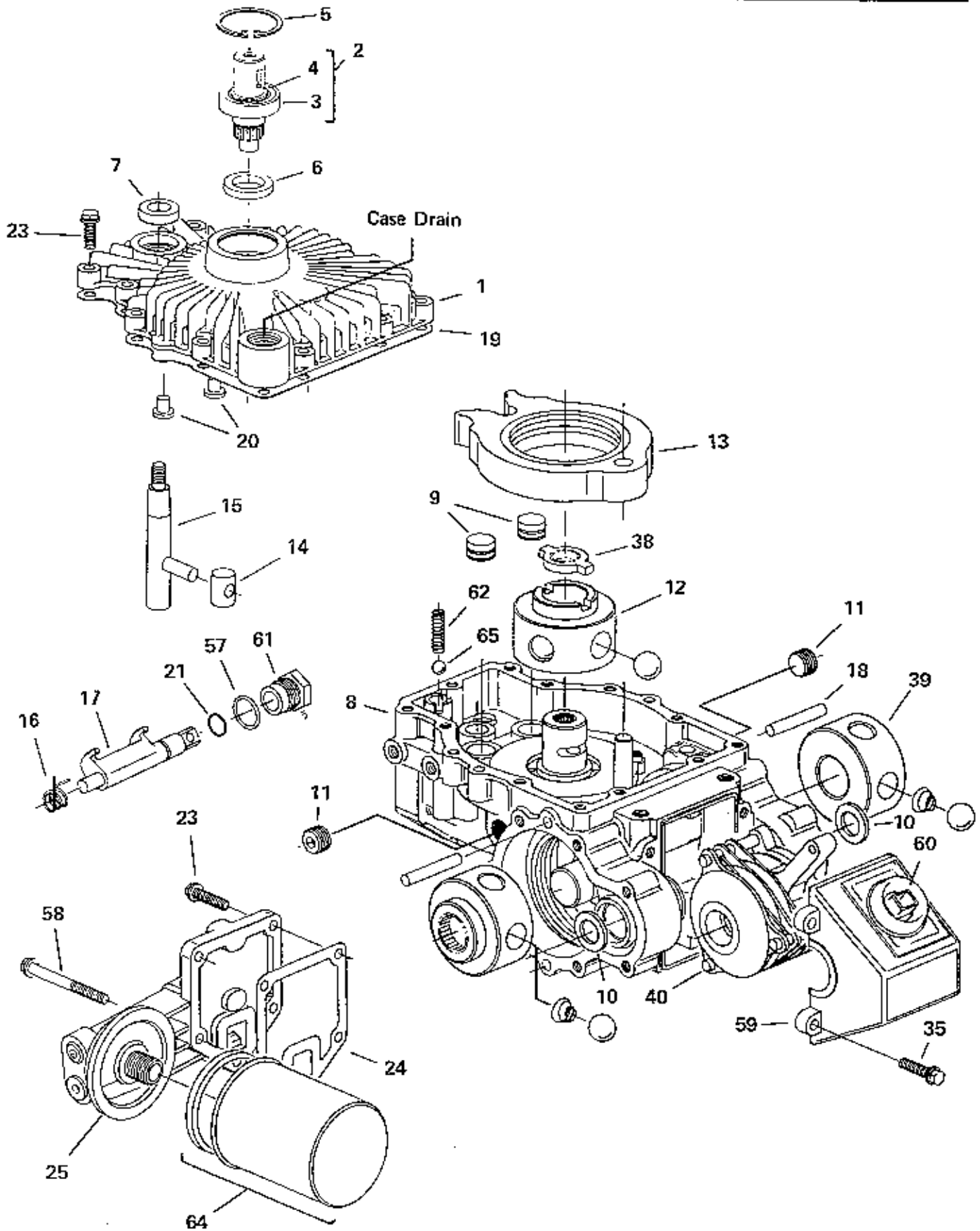

Ref. No.	Part No.	Qty.	Description
1	1702706	1	COVER, Subassembly (S/A)
2	1702247	1	SHAFT, Input, S/A (Incl. 3 & 4)
3		1	BEARING (Not Serviced Separately)
4		1	RING (Not Serviced Separately)
5	1702707	1	RING, Retaining, Internal
6	1702248	1	SEAL, Oil
7	1671300	1	SEAL, Oil
8	1702708	1	HOUSING, S/A, Clockwise
9	1702709	2	PISTON, Quieting, S/A
10	1702249	2	SEAL, Lip, Radial
11	1702250	2	PLUG, Socket Pipe
12	1702710	1	PUMP, Rotor-Ball Pin, S/A
13	1702711	1	CAM RING, S/A
14	1702251	1	INSERT
15	1702252	1	CONTROL SHAFT, S/A
16	1702253	1	SPRING, Dump Valve
17	1702254	1	BRACKET
18	1702712	4	DOWEL
19	1702255	1	GASKET, Cover
20	1702256	2	BUTTON
21	1671297	1	O-RING
23	1702705	16	CAPSCREW, Hex, Flange, 1/4-20
24	1702258	1	GASKET, Filter Base
25	1702713	1	FILTER BASE, S/A
35	1702268	4	SCREW, 1/4-20 Self Tap
38	1702714	1	DRIVE
39	1702715	2	MOTOR ROTOR-BALL, A & B S/A, 15T
40	1702271	1	BRAKE, Parking, Assembly
57	1702284	2	O-RING, Fitting
58	1702285	2	SCREW, 1/4-20 Hex Flange
59	1702286	1	COVER, Parking Brake
60	1702287	1	BOOT, Dust
61	1702720	1	FITTING
62	1702721	1	SPRING, Relief Valve
64	1702282	1	FILTER, Oil (w/Seal), Special - 10 Micron
65	1702281	1	BALL, Grade 200
	*1702280	1	GASKET OVERHALL KIT (Incl. Ref. Nos. 19, 22 & 24)

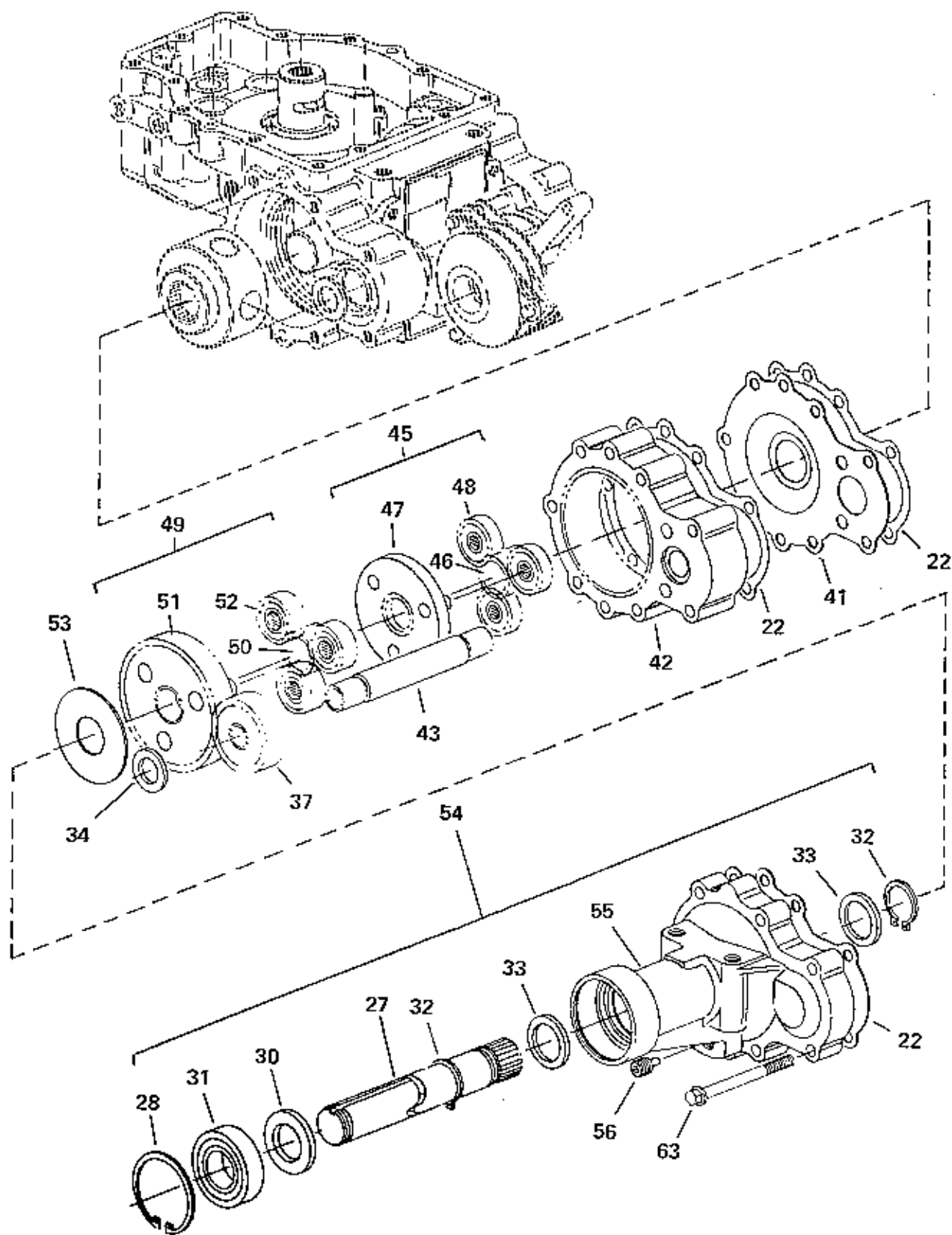

Ref. No.	Part No.	Qty.	Description
22	1702257	6	GASKET, Axle Housing
27	1702260	1	SHAFT, Axle
28	1702261	2	RETAINING RING, Internal
30	1702263	2	LIP SEAL, Radial
31	1702264	2	BEARING, Ball
32	1702265	4	RETAINING RING, External
33	1702266	4	WASHER, Thrust
34	1702267	1	SPACER
37	1702270	2	LOCK GEAR, Differential
41	1702272	2	PLATE, Wear
42	1702716	2	RING GEAR, A & B S/A, 57T
43	1702717	1	BRAKE SHAFT - A
45	1702273	2	PLANETARY GEAR, First, Subassembly (Incl. Ref. Nos. 46, 47 & 48)
46		2	SUN GEAR, First, 15T (See Ref. No. 45)
47		2	PRIMARY CARRIER, A & B S/A, 15T (See Ref. No. 45)
48		6	PLANETARY GEAR, First, A & B S/A, 21T (See Ref. No. 45)
49	1702274	2	PLANETARY GEAR, Second, A & B S/A (Incl. Ref. Nos. 50, 51 & 52)
50		2	SUN GEAR, Second, 15T (See Ref. No. 49)
51		2	SECONDARY CARRIER, A & B S/A (See Ref. No. 49)
52		6	PLANETARY GEAR, A & B S/A, Second, 21T (See Ref. No. 49)
53	1702719	2	WASHER, Thrust
54	1702275	1	AXLE HOUSING, S/A - A
55	1702278	1	HOUSING, Axle - A
56	1702283	2	PLUG, Magnetic
63	1960340	14	CAPSCREW, 1/4-20 Hex Flange x 2-3/4
	*1702280	1	Gasket Overhaul Kit (Incl. Ref. Nos. 19, 22 & 24)

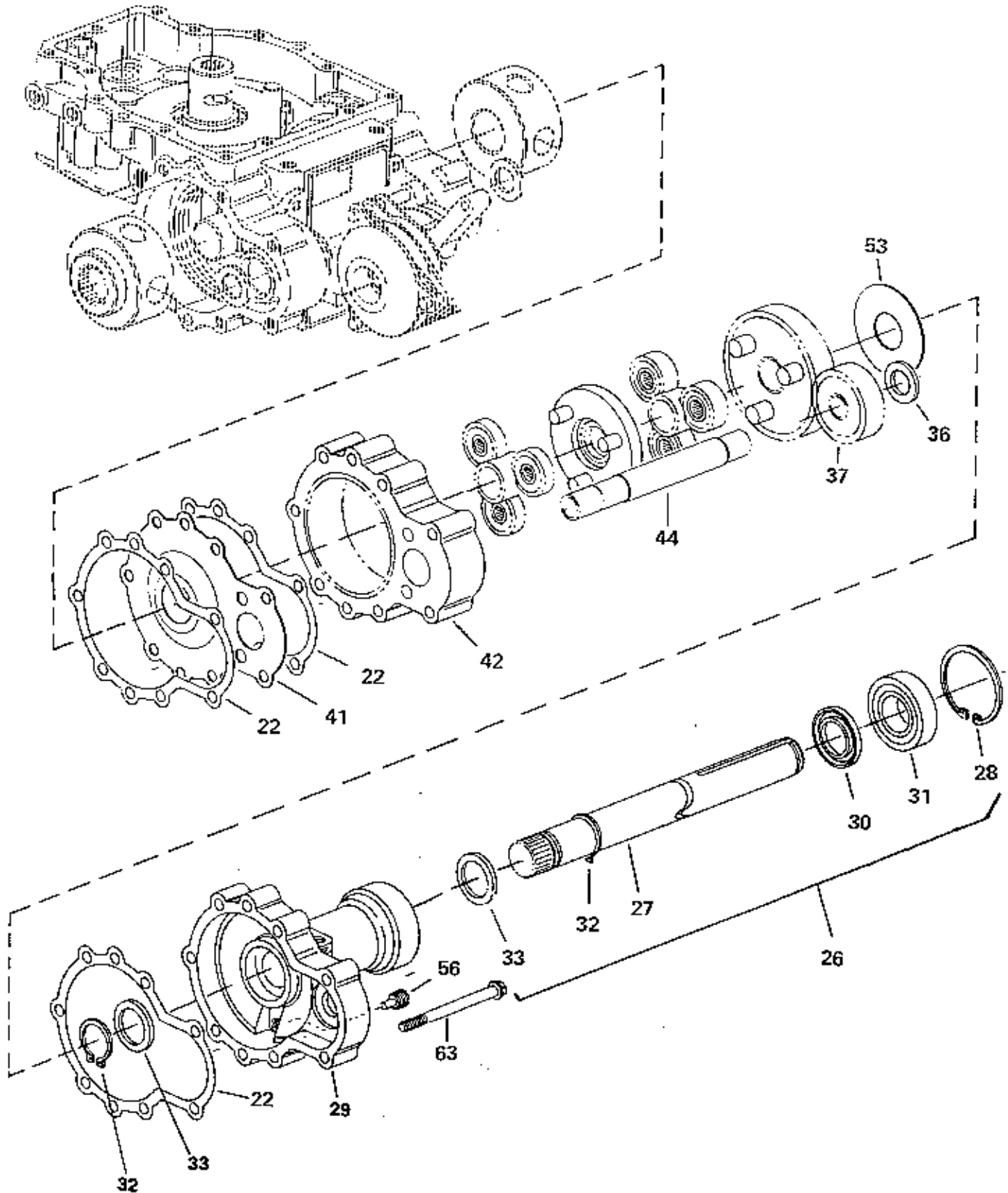

Ref. No.	Part No.	Qty.	Description
*22	1702257	6	GASKET, Axle Housing
26	1702259	1	AXLE HOUSING, S/A - B
27	1702260	1	SHAFT, Axle
28	1702261	2	RETAINING RING, Internal
29	1702262	1	HOUSING, Axle - B
30	1702263	2	LIP SEAL, Radial
31	1702264	2	BEARING, Ball
32	1702265	4	RETAINING RING, External
33	1702266	4	WASHER, Thrust
36	1702269	1	SPACER
37	1702270	2	LOCK GEAR, Differential
41	1702272	2	PLATE, Wear
42	1702716	2	RING GEAR, A & B S/A, 57T
44	1702718	1	BRAKE SHAFT - B
53	1702719	2	WASHER, Thrust
56	1702283	2	PLUG, Magnetic
63	1960340	14	CAPSCREW, 1/4-20 Hex Flange x 2-3/4
	*1702280	1	GASKET OVERHAUL KIT (incl. Ref. Nos. 19, 22 & 24)

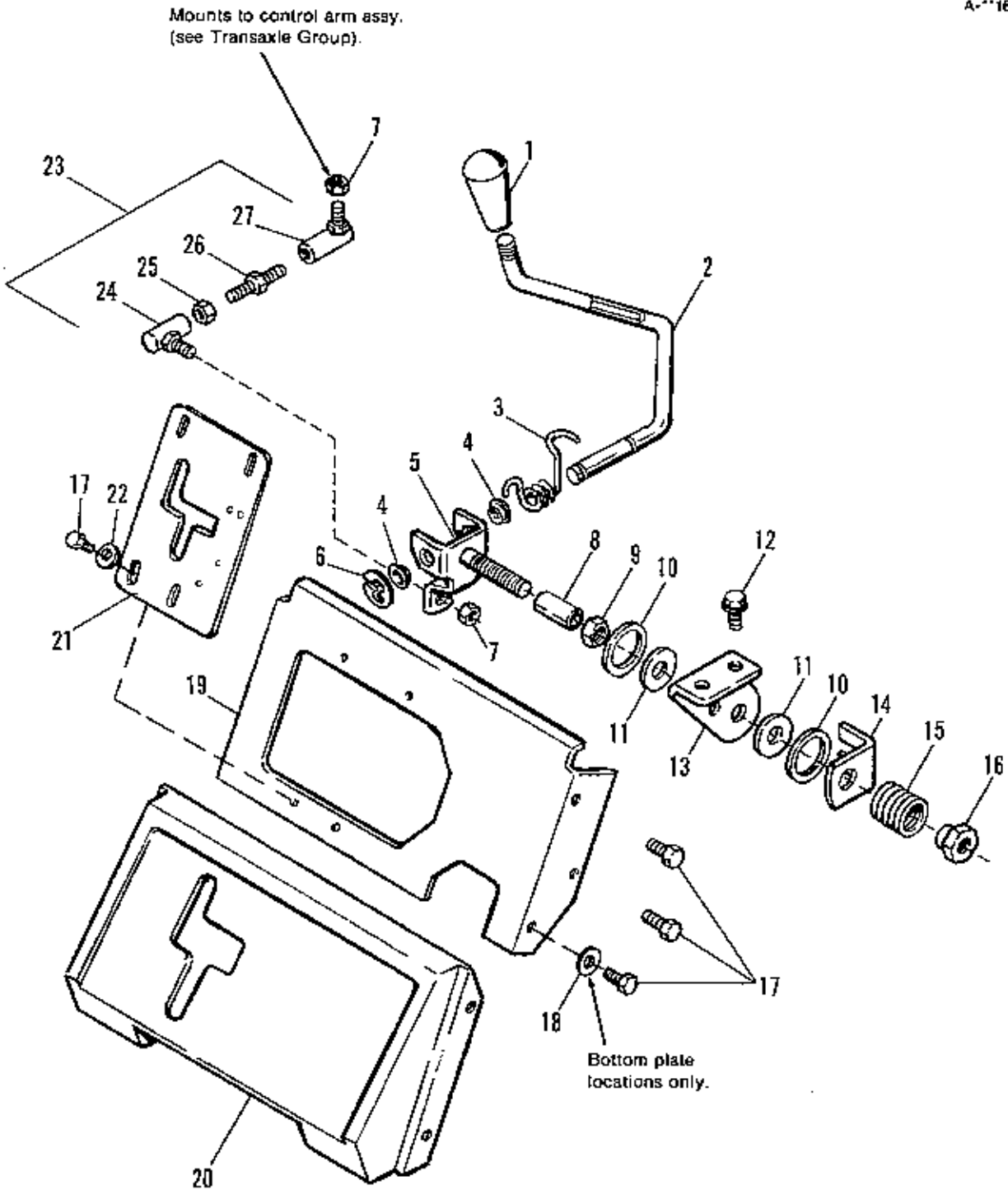

NOTE: Use standard hardware
torque spec. chart unless
otherwise noted.

Ref. No.	Part No.	Qty.	Description
1	1702652	1	HANDLE, Speed Control
2	1700877	1	ROD
3	1700878	1	SPRING, Torsion
4	1669197	2	BUSHING
5	1702380	1	BRACKET ASSY., Speed Control
6	158399	1	E-RING
7	1930628	2	NUT, Centerlock, 3/8-24
8	1679740	1	SPACER
9	1930651	1	NUT, Hex Lock, 3/8-16
10	1702585	2	RING, Containment
11	1674461	2	DISC, Friction
12	1930601	1	SCREW, Taptite, 5/16-18 x 5/8
13	1701248	1	BRACKET, Speed Control Support
14	1702217	1	BRACKET, Pivot
15	1702067	1	SPRING, Compression
16	1702223	1	NUT, Spacer
17	1925003	10	SCREW, Taptite, 1/4-20 x 1/2
18	1917377	2	WASHER, 1/4
19	1702628	1	PLATE, Quadrant Mounting
20	1679739	1	PANEL, Shift
21	1702244	1	QUADRANT, Speed Control
22	1921319	4	WASHER, 1/4
23	1702245	1	BALL JOINT ASSY., (Incl. Ref. Nos. 24 - 27)
24	1702230	1	BALL JOINT, R.H. Thrd.
25	1918403	1	JAM NUT, 3/8-24
26	1702225	1	ADJUSTER ROD
27	1702231	1	BALL JOINT, L.H. Thrd.

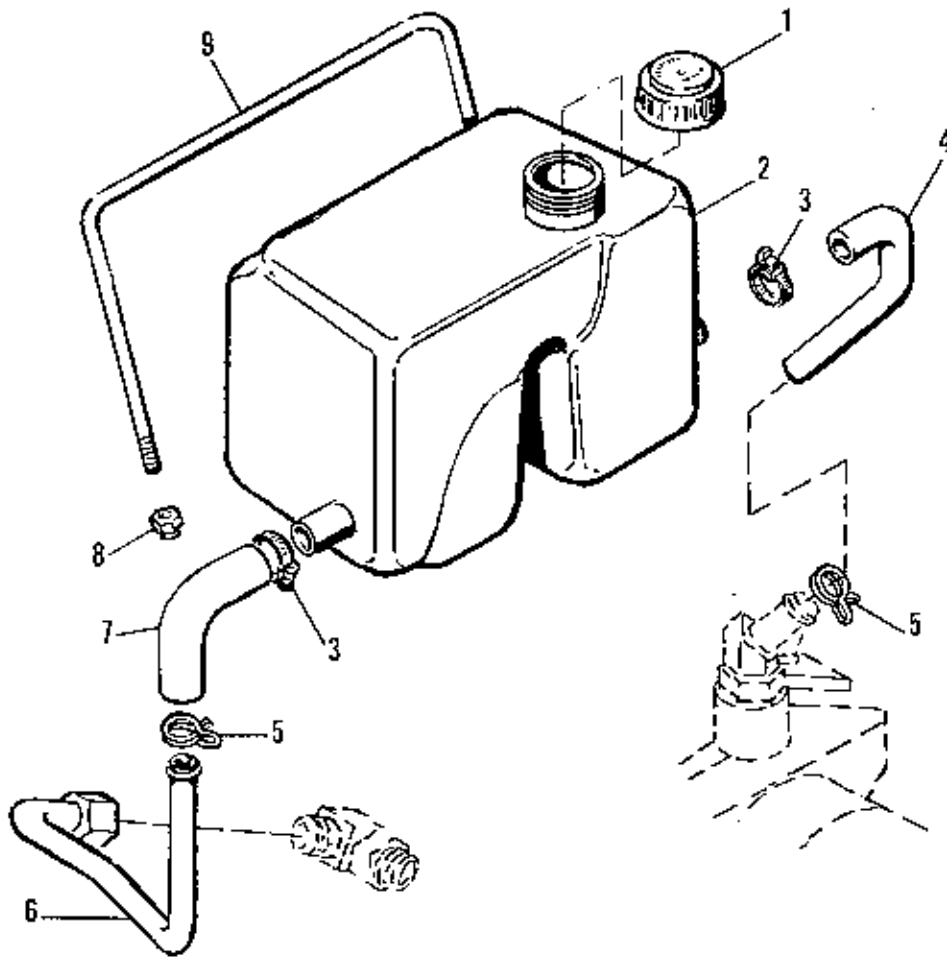

NOTE: Use standard hardware
torque spec. chart unless
otherwise noted.

Ref. No.	Part No.	Qty.	Description
1	1676467	1	CAP, Reservoir
2	1700847	1	RESERVOIR (1 Gal.)
3	960266	2	CLAMP, Hose, #10
4	1700344	1	HOSE, Hydraulic
5	1701236	2	CLAMP, Hose
6	1700920	1	LINE, Hydraulic, Steel
7	1700881	1	HOSE, Hydraulic
8	1920397	2	NUT, Hex, 1/4-20
9	1700821	1	ROD, Reservoir Mtg.

Mounts to capscrews,
Ref. No. 60, pages 2 & 4.

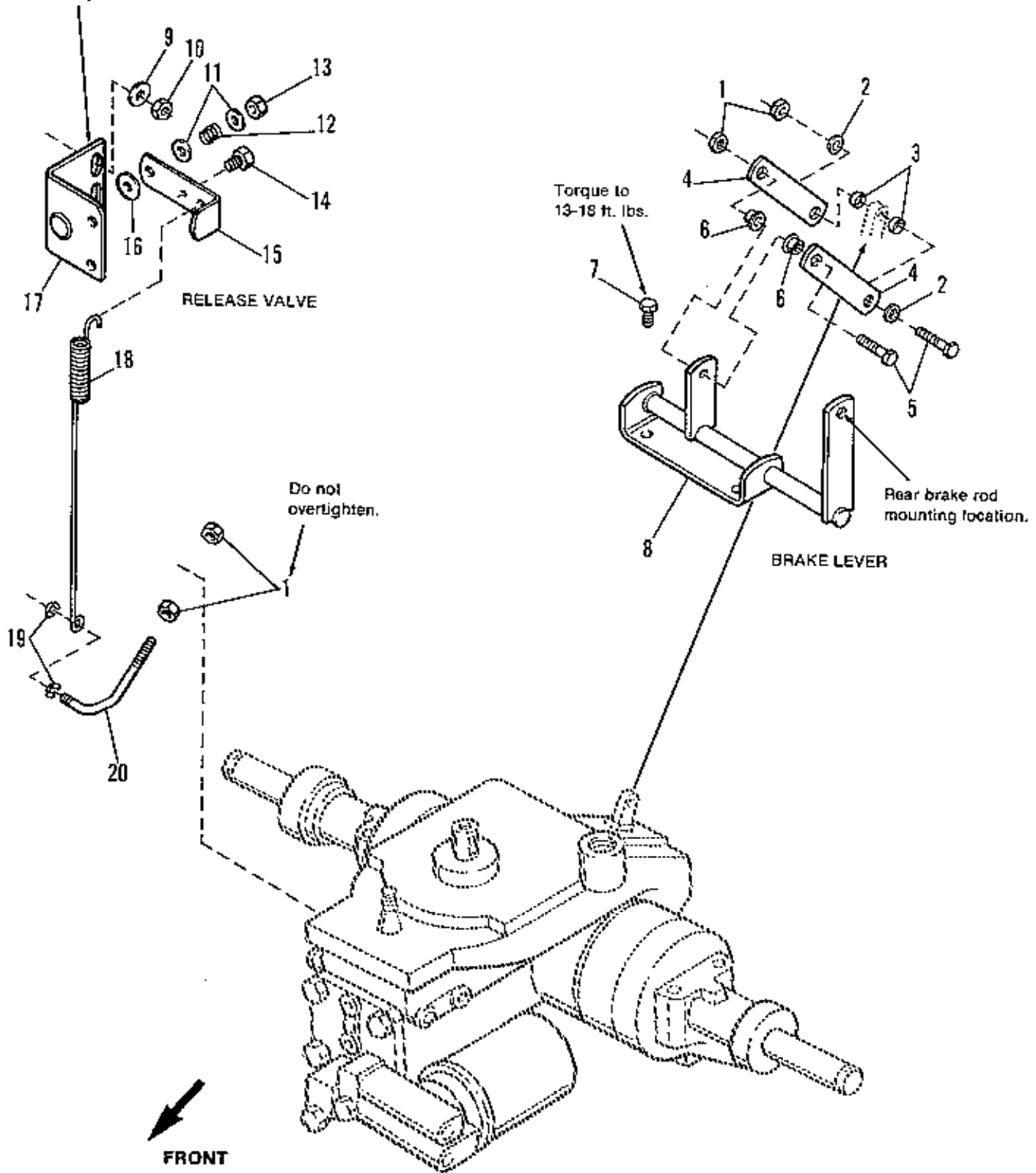

NOTE: Use standard hardware
torque spec. chart unless
otherwise noted.

Ref. No.	Part No.	Qty.	Description
1	1923358	4	NUT, Hex Lock, 1/4-20
2	1921319	2	WASHER, Flat
3	1702219	2	SPACER
4	1702377	2	BRACKET, Brake Clevis
5	1928745	2	CAPSCREW, 1/4-20 x 1-1/4
6	1702220	2	SPACER, Shoulder
7	1925205	2	CAPSCREW, 5/16-18 x 5/8
8	1702370	1	BRACKET ASSY., Brake Lever
9	1917642	2	WASHER
10	1917372	2	NUT, Hex, 5/16-18
11	1917377	2	WASHER, 1/4
12	171651	1	SPRING, Compression
13	1923358	1	NUT, Center Lock, 1/4-20
14	1927428	1	SCREW, Taptite, 1/4-20 x 3/8
15	1702635	1	LEVER, Release Valve
16	1678366	1	WASHER, Nylon
17	1702632	1	BRACKET ASSY., Release Valve
18	1702636	1	SPRING, Tension
19	1702651	2	KLIP RING
20	1702634	1	LEVER, Hydro Release Valve

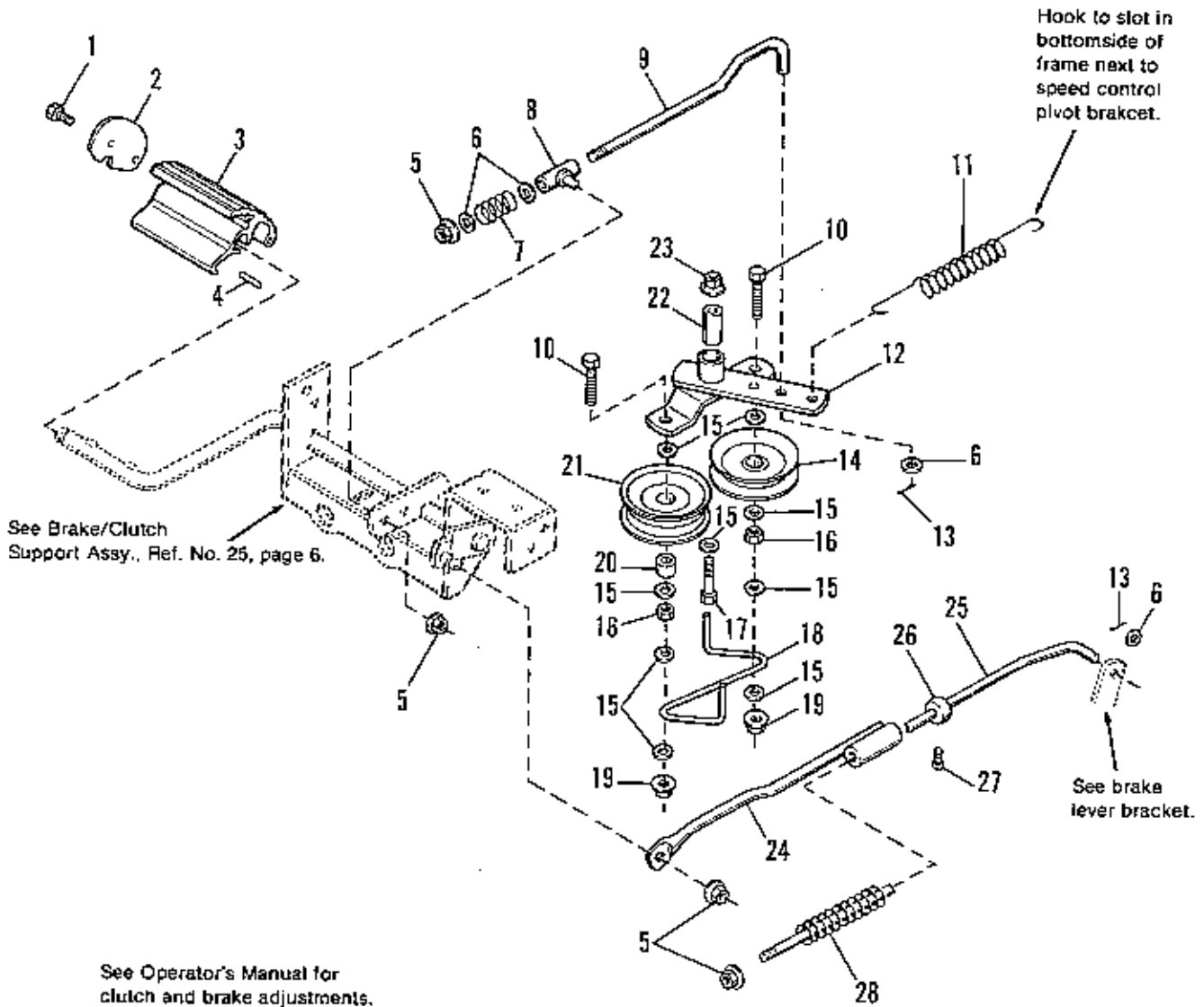

Ref. No.	Part No.	Qty.	Description
1	1927429	2	SCREW, Taptite, 1/4-20 x 5/8
2	1656854	1	PLATE, End
3	1656852	1	PEDAL, Brake
4	1657322	1	DAMPER, Rubber
5	1935048	4	NUT, Flange Lock, 5/16-18
6	1919326	4	WASHER
7	152006	1	SPRING, Compression
8	164094	1	GUIDE ASSY., Rod
9	1702401	1	ROD, Clutch
10	1929116	2	CAPSCREW, 3/8-16 x 2, Full Thread
11	165068	1	SPRING, Tension
12	1679857	1	BRACKET ASSY., Idler
13	1918447	2	PIN, Cotter
14	174561	1	PULLEY, V-Idler
15	1922755	9	WASHER
16	1917421	2	NUT, Jam, 3/8-16
17	1923701	1	CAPSCREW, 3/8-16 x 2
18	1702403	1	GUIDE, Belt
19	1930645	2	NUT, Hex, 3/8-16
20	1666294	1	SPACER (For Flat-Side Pulley)
21	1685151	1	PULLEY, Flat-Side
22	1679740	1	SPACER
23	1928352	1	NUT, Whiz Flange
24	1702387	1	ROD ASSY., Brake
25	1702386	1	ROD, Brake
26	8191022	1	COLLAR, Set
27	1928804	1	SET SCREW, Sq. Hd.
28	163103	1	SPRING, Compression

A-1607

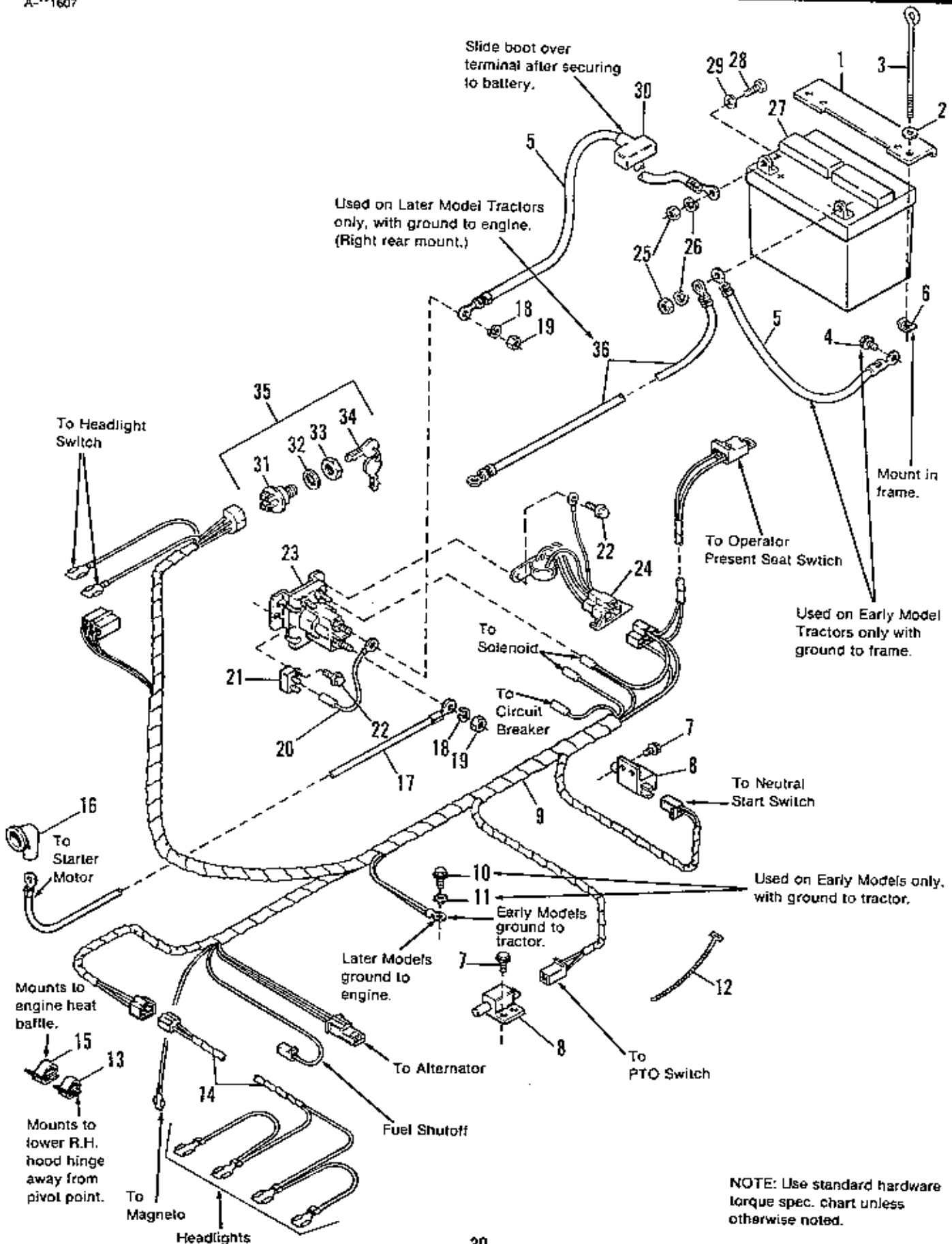

Ref. No.	Part No.	Qty.	Description
1	1669831	1	HOLD DOWN, Battery
2	1917377	2	WASHER, 1/4
3	1700472	2	ROD, Battery Hold Down
4	927428	1	SCREW, Taptite, 1/4-20 x 3/8, Zinc Pltd.
5	1603618	2	CABLE, Ground (Qty. 1 on later models)
6	926022	2	NUT, Retainer, 1/4-20
7	1929477	4	SCREW, Taptite, #10-24 x 1/2
8	1701521	2	SWITCH, PTO and Neutral
9	1685379	1	HARNESSES, Wiring (1691263 & 1691468 only)
	1703227	1	HARNESSES, Wiring (1691736 only)
10	927428	1	SCREW, Taptite, 1/4-20 x 3/8
11	921880	1	WASHER, Ext. Tooth
12	932747	1	TIE, Cable
13	930222	1	CLIP, Wire
14	1674358	1	WIRE ASSY., Headlights
15	165073	1	CLIP, Wire
16	122023	1	COVER, Terminal
17	1701522	1	CABLE
18	1917356	2	LOCKWASHER, 5/16
19	1920263	2	NUT, Hex, 5/16-24
20	1665237	1	WIRE ASSY.
21	1665238	1	CIRCUIT BREAKER
22	927429	2	SCREW, Taptite, 1/4-20 x 5/8
23	1685290	1	SOLENOID
24	1672654	1	MODULE, DSI Interlock
25	916622	2	NUT, Hex, 1/4-20
26	916964	2	LOCKWASHER, 1/4
27	1685215	1	BATTERY, 39 Amp.
28	1923341	2	CAPSCREW, Hex Hd., 1/4-20 x 3/4
29	921319	2	WASHER, 1/4 I.D.
30	1677296	1	BOOT, Insulator
31		1	SWITCH (See Ref. No. 35)
32	918906	1	LOCKWASHER, Internal, 5/8
33	122234	1	NUT, Hex, 5/8-32
34	122203	1	KEYS
35	1674244	1	SWITCH, Ignition (Incl. Ref. Nos. 31, 32, 33 & 34)
36	1703484	1	CABLE, Ground to Engine (Later Models Only)

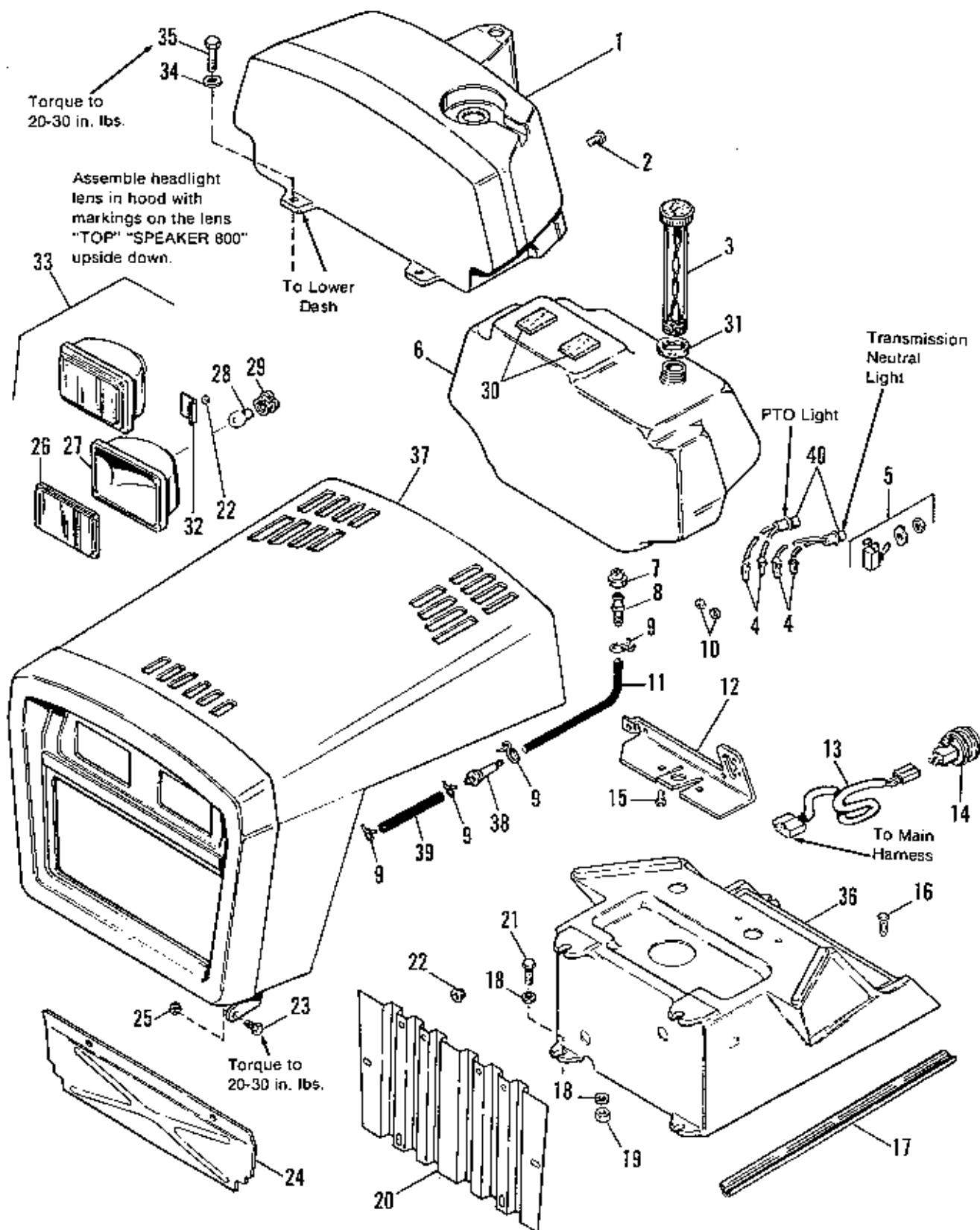

NOTE: Use standard hardware torque spec. chart unless otherwise noted.

Ref. No.	Part No.	Qty.	Description
1	1673058	1	DASHBOARD, Top
2	1676860	2	SCREW, Type "AB" 1/4-14 x 5/8
3	171252	1	CAP, Fuel Tank
4	1701502	2	LIGHT, Indicator (Incl. Ref. No. 40)
5	122184	1	SWITCH, Toggle (Lights)
6	1685297	1	TANK ASSY., Fuel (Incl. Ref. Nos. 7, 8, 9 & 10)
7	1654930	1	BUSHING
8	1666447	1	FITTING
9	1960112	2	CLAMP, Hose (Qty. 4 on 1691732)
10	1673013	2	NUT, Push On
11	1676861	1	HOSE, Fuel
12	1665301	1	BRACE, Dashboard
13	1701312	1	WIRE ASSY.
14	1701525	1	HOUR METER
15	1925592	2	SCREW, Taptite, 1/4-2 x 3/4
16	1667248	8	CLIP, Canoe
17	1672123	2	EDGING, Lower Dash
18	1931704	6	LOCKWASHER, Dished, 1/4
19	1923358	2	LOCKNUT, 1/4-20
20	1665790	1	SCREEN, Grille (1691263 & 1691468 only)
	1702934	1	SCREEN, Grille (1691732 only)
21	1929783	4	SCREW, Taptite, 1/4-20 x 1
22	1665253	10	NUT, Pal, Hex, #10-24
23	1921966	2	CAPSCREW, 3/8-16 x 7/8
24	1665751	1	BAFFLE, Engine Front (1691263 & 1691468 only)
25	1930651	2	LOCKNUT, 3/8-16
26	1677368	2	LENS, Clear
27	1677369	2	HOUSING
28	1677371	2	BULB
29	1677370	2	SOCKET, Bulb
30	173335	2	PAD
31	1664897	1	WASHER, Foam
32	1675932	4	CLIP, Headlight Mtg.
33	1674363	2	HEADLIGHT ASSY. (Incl. Ref. Nos. 26, 27, 28 & 29)
34	1917377	2	WASHER, 1/4
35	1921961	2	SCREW, Hex, 1/4-20 x 1-1/4
36	1668641	1	DASHBOARD, Bottom
37	1679976	1	HOOD & GRILLE ASSY.
38	173206	1	FILTER, Fuel (1691732 only)
39	1666276	1	HOSE, Fuel, 17" (1691732 only)
40	1703566	2	LENS ONLY

NOTE: Early Model Seat Switch mounts with 1/2" long cap screws.

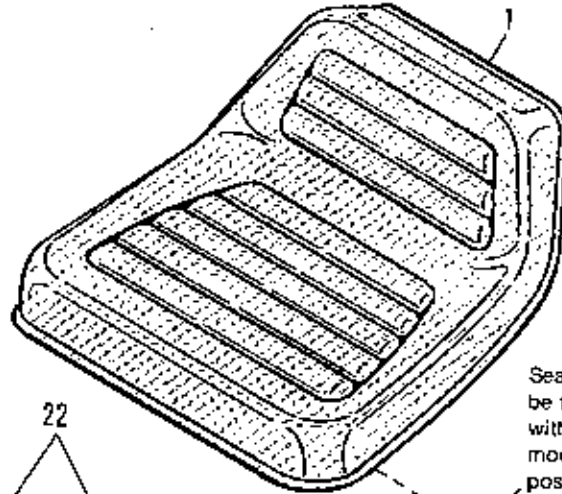
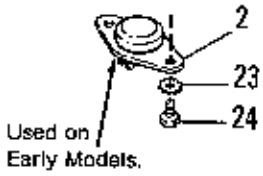

Seat switch must be tested for function with seat switch mounted in proper position on seat.

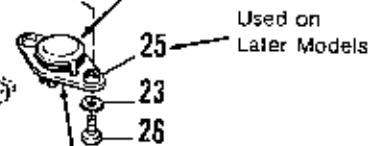

NOTE: Later Model Seat Switch has raised bosses and requires 3/4" long cap screws.

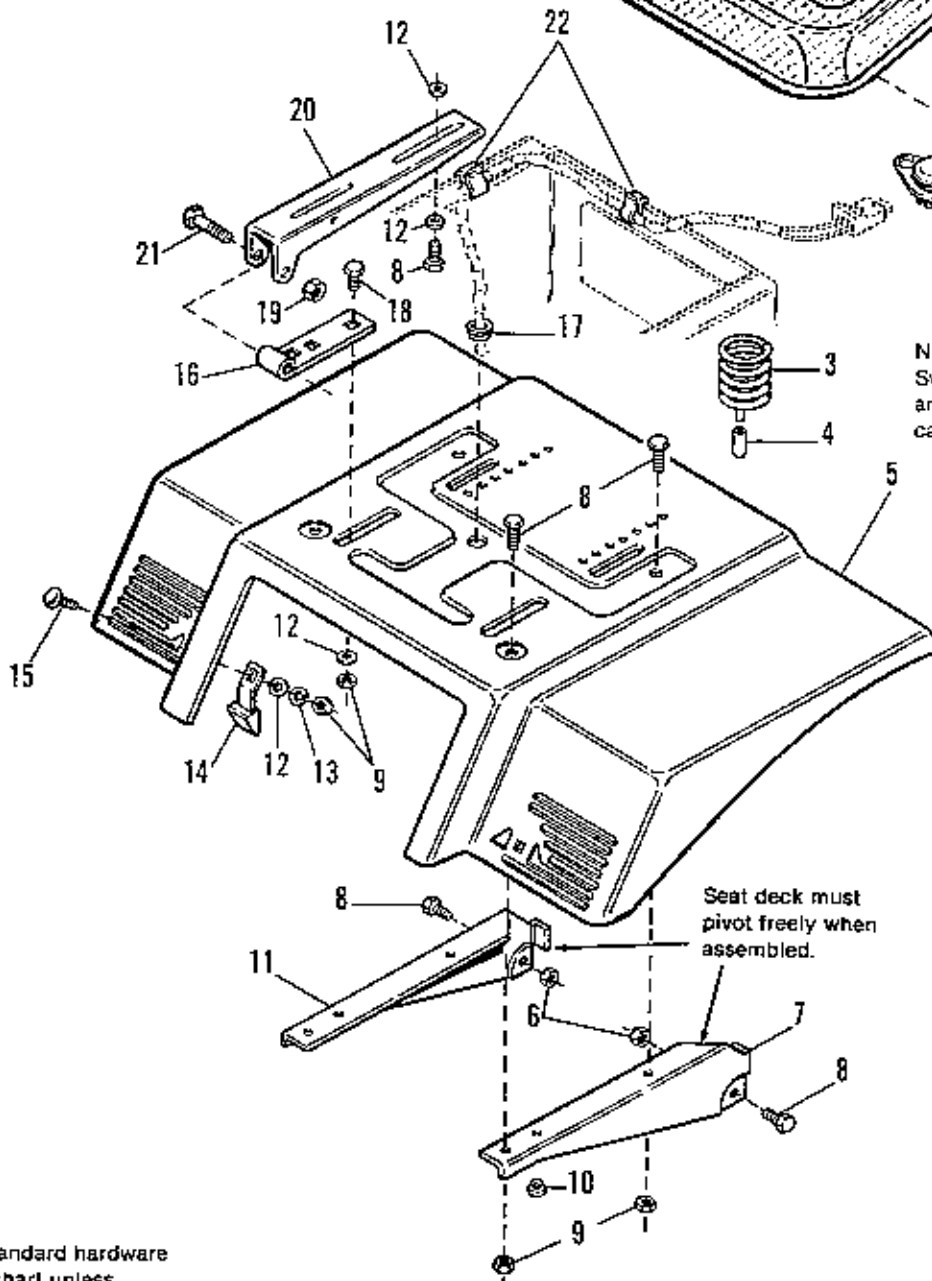

Seat deck must pivot freely when assembled.

NOTE: Use standard hardware torque spec. chart unless otherwise noted.

Seat & Deck Group

Ref. No.	Part No.	Qty.	Description
1	1611779	1	SEAT
2	1700636	1	SWITCH, Seat (Early Models)
3	1666690	2	SPRING, Seat
4	1666691	2	COVER, Wire
5	1702690	1	DECK, Seat
6	1923362	2	NUT, Lock, Hex, 5/16-18
7	1701737	1	SUPPORT, Seat, L.H.
8	1921332	10	CAPSCREW, Hex Hd., 5/16-18 x 3/4
9	1917372	10	NUT, Hex, 5/16-18
10	1701742	2	BUMPER, Plug
11	1701736	1	SUPPORT, Seat, R.H.
12	1917642	10	WASHER, 5/16
13	1917356	2	LOCKWASHER, 5/16
14	1701252	2	SEAT LATCH ASSY.
15	1931333	2	BOLT, Carriage, 5/16-18 x 3/4
16	1678415	2	HINGE, Lower
17	1701229	1	BUSHING, Snap
18	1921333	4	CAPSCREW, Hex Hd., 5/16-18 x 1
19	1930651	2	NUT, Hex Lock, 3/8-18
20	1701559	2	HINGE, Upper
21	1923701	2	CAPSCREW, Hex Hd., 3/8-16 x 2
22	930222	2	CLIP
23	1921880	2	LOCKWASHER, Ext. Tooth, 1/4
24	1928025	2	SCREW, Rd. Hd., 1/4-20 x 1/2 (Early Models only)
25	1703373	1	SWITCH, Seat (Later Models)
26	1980357	2	SCREW, Rd. Hd., 1/4-20 x 3/4

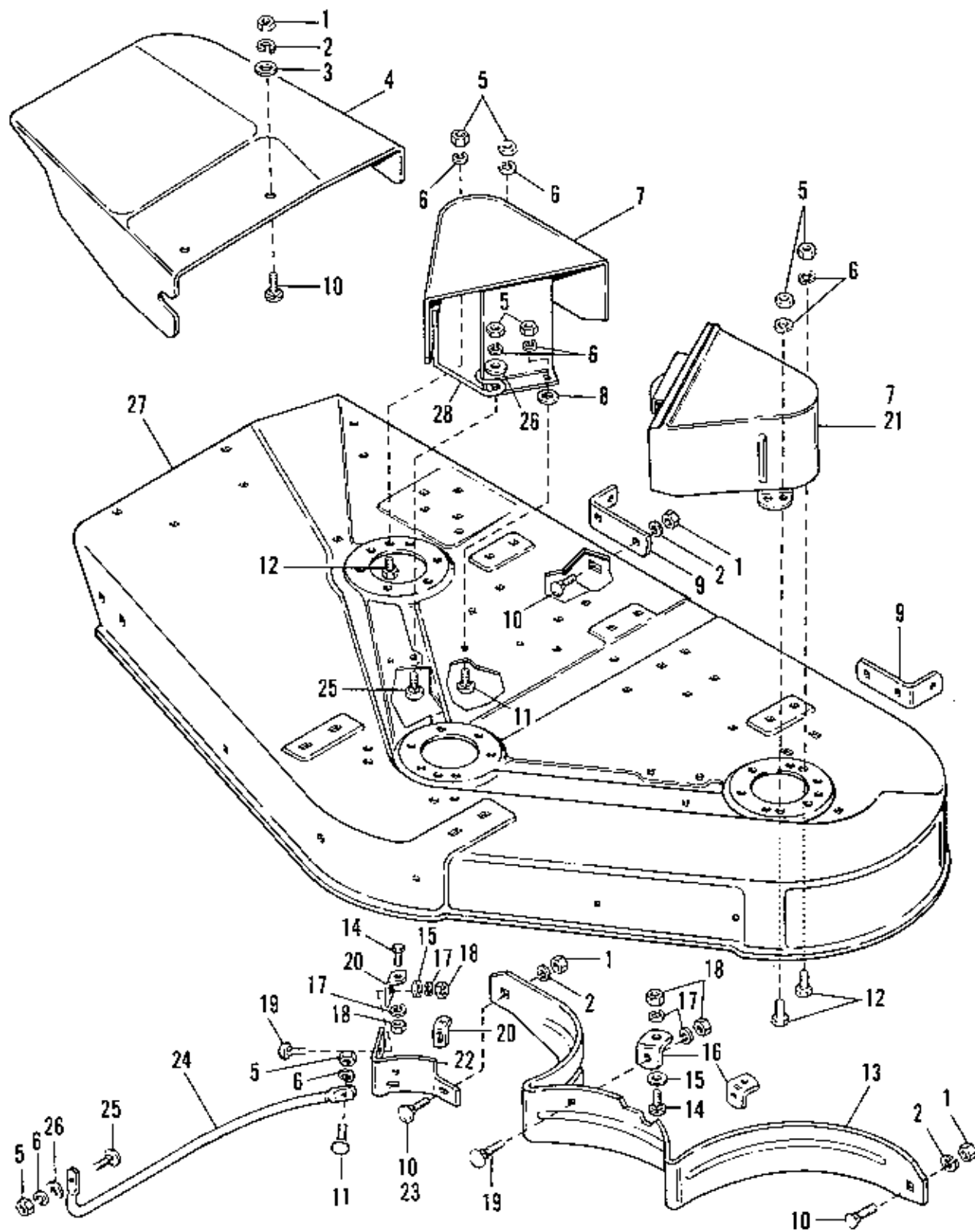

NOTE: Use standard hardware torque spec. chart unless otherwise noted.

Ref. No.	Part No.	Qty.	Description
1	1916950	8	NUT, Hex, 3/8-16 (Qty. 7 used on 48")
2	1916965	8	LOCKWASHER, 3/8 (Qty. 7 used on 48")
3	1917378	2	WASHER, Plain, 3/8
4	1656049	1	DEFLECTOR
5	1917372	8	NUT, Hex, 5/16-18 (Qty. 6 used on 42")
6	1917356	8	LOCKWASHER, 5/16 (Qty. 6 used on 42")
7	1702214	2	ARBOR COVER ASSY. (Qty. 1 used on 42")
8	933988	4	PUSHNUT, 5/16 (Qty. 2 used on 42")
9	1603264	2	BRACKET, Roller Support
10	1931348	8	BOLT, Carriage, 3/8-16 x 3/4 (Qty. 7 used on 48")
11	1931333	4	BOLT, Carriage, 5/16-18 x 3/4 (Qty. 2 used on 42")
12	1921333	4	CAPSCREW, Hex, 5/16-18 x 1
13	1608135	1	BAFFLE - 42"
	1608327	1	BAFFLE - 48"
14	1923341	4	CAPSCREW, Hex, 1/4-20 x 3/4
15	1917377	4	WASHER, 1/4
16	1608331	2	CLIP, Baffle
17	1916964	8	LOCKWASHER, 1/4
18	1916622	8	NUT, Hex, 1/4-20
19	1923333	4	BOLT, Carriage, 1/4-20 x 5/8
20	108186	2	CLIP GUARD & BAFFLE
21	1702213	1	ARBOR COVER ASSY. - 42"
22	1665709	1	BAFFLE, Discharge
23	1931350	1	BOLT, Carriage, 3/8-16 x 1.00 (48" only)
24	1665562	1	GUARD, Mower Discharge
25	1931335	2	BOLT, Carriage, 5/16-18 x 1
26	1919381	4	WASHER, 11/32 x 1
27	1685156	1	42" ROTARY MOWER HOUSING KIT (Incl. Safety Decals)
	1685154	1	48" ROTARY MOWER HOUSING KIT (Inc. Safety Decals)
28	1666888	1	STOP, Belt

Torque to 50 - 70 ft. lbs.

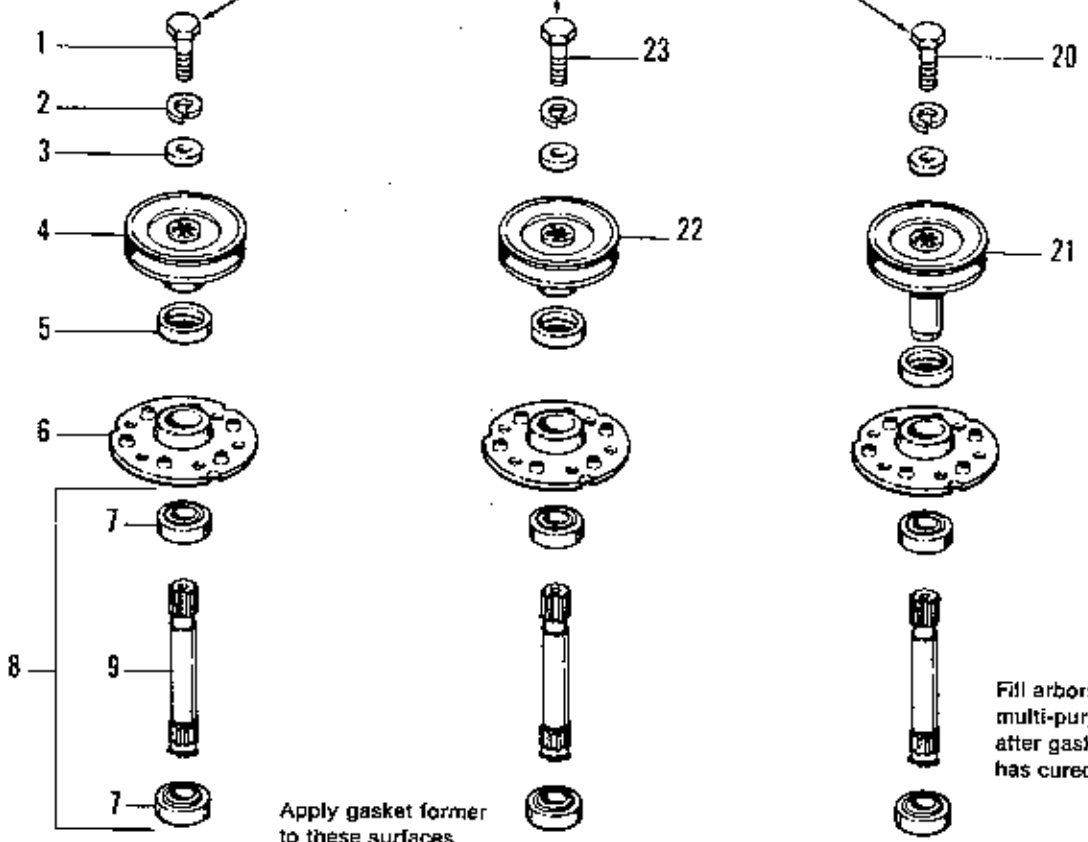

Apply gasket former to these surfaces

Fill arbors with multi-purpose grease after gasket former has cured.

Torque to 15 - 19 ft. lbs. (18 places).

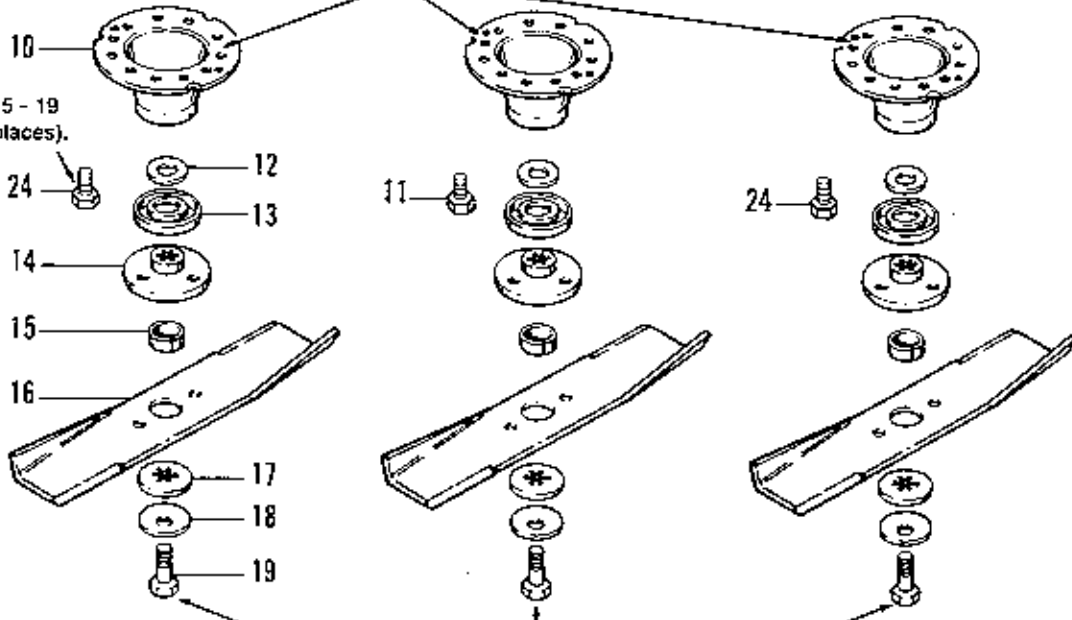

NOTE: Use standard hardware torque spec. chart unless otherwise noted.



Torque to 50 - 70 ft. lbs.

Ref. No.	Part No.	Qty.	Description
1	1923451	1	CAPSCREW, Hex 7/16-14 x 1/2
2	1918199	3	LOCKWASHER, 7/16
3	1933263	3	WASHER, Plain, 29/64 x 1-1/4 x 1/4
4	1702153	1	PULLEY ASSY.
5	1657969	3	SHIELD, Bearing Upper
6	1655729	3	HOUSING TOP
7	108202	6	BEARING
8	1685251	3	SHAFT & BEARING ASSY. (Incl. Ref. Nos. 7, 9 & 15)
9	1685245	3	SHAFT, Arbor (Incl. Ref. No. 15)
10	1703273	3	HOUSING, Bottom
11	1664847	6	SCREW, Hex, Taptite, 5/16-18 x 3/4
12	1700230	3	WASHER, Shim
13	1700229	3	SHIELD, Grass
14	1655777	3	ADAPTOR, Blade
15	1672132	3	COLLAR
16	1656147	3	BLADE, 42" Mower
	1656146	3	BLADE, 48" Mower
17	1656927	3	WASHER, Spline
18	1656916	3	WASHER, Spring
19	1923491	3	CAPSCREW, Hex 7/16-14 x 1
20	1930585	1	CAPSCREW, Hex, 7/16-14 x 3-1/2
21	1665347	1	PULLEY ASSY.
22	1665476	1	PULLEY ASSY.
23	1936723	1	CAPSCREW, Hex, 7/16-14 x 1-3/4
24	1927477	12	SCREW, Hex Taptite, 5/16-18 x 1

ASSEMBLY PROCEDURES

- A. Press (2) bearings (Ref. No. 7) with land riding seal (see note below) facing up over shafts (Ref. No. 9) using pressure only on the inner race of the bearing. NOTE: Land riding seal is side of bearing without steel shield. If bearing has shield on both sides, it can be installed either way.
- B. Assemble upper and lower arbor housing (Ref. Nos. 6 & 10) over bearings. Must be careful that housings do not cock on bearings. When upper and lower housing flanges come together proper alignment of holes in housing flanges are accomplished by aligning knockouts in lower housing flange with mating holes in upper housing flange. Also half holes in outer edge must match.
- C. Seal between flanges of upper arbor housing and lower arbor housing with gasket eliminator. Remove contaminants such as grease, heavy oils and dirt from flange surfaces before assembly. Avoid lateral movement between flange surfaces during assembly.

NOTE: See Operator's Manual for
Blade Brake Adjustment Procedures.

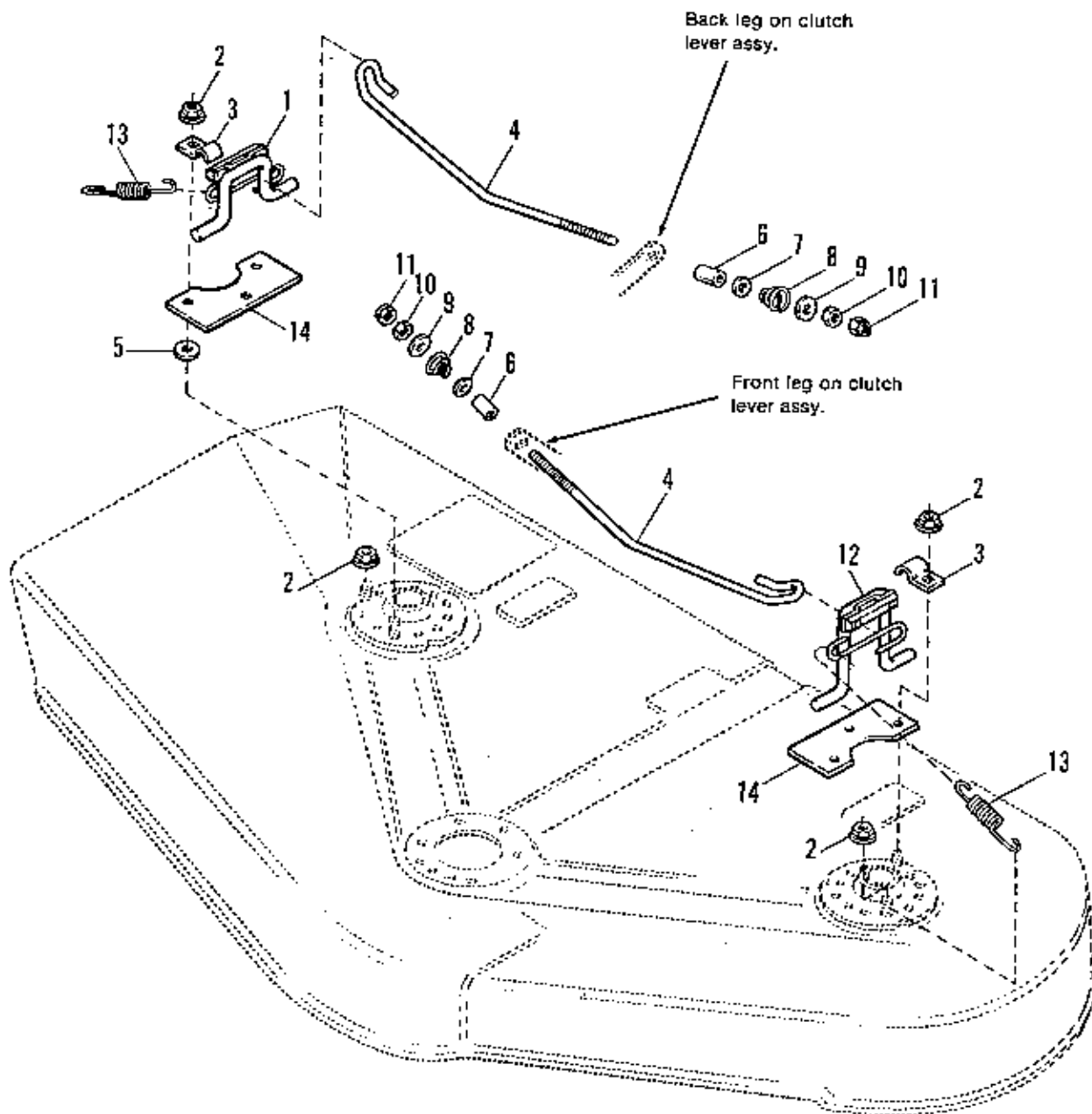

NOTE: Use standard hardware
torque spec. chart unless
otherwise noted.

42" & 48" Brake Group

Ref. No.	Part No.	Qty.	Description
1	1701764	1	ROD ASSY., Brake, R.H. w/Pad
2	1935048	6	NUT, Hex, Flange Lock, 5/16-18
3	1664004	4	CLIP
4	1701866	2	ROD, Brake, 42"
	1701867	2	ROD, Brake, 48"
5	1922755	2	WASHER, 13/32 x 1
6	1664857	2	SPACER
7	1917377	2	WASHER, 1/4
8	1676253	2	SPRING
9	1919381	2	WASHER, 11/32 x 1
10	1916622	2	NUT, Hex Full, 1/4-20
11	1920397	2	NUT, Hex Lock, Esna Light, 1/4-20
12	1701765	1	ROD ASSY., Brake, L.H. w/Pad
13	1702246	2	SPRING, Extension
14	1701747	2	BRACKET

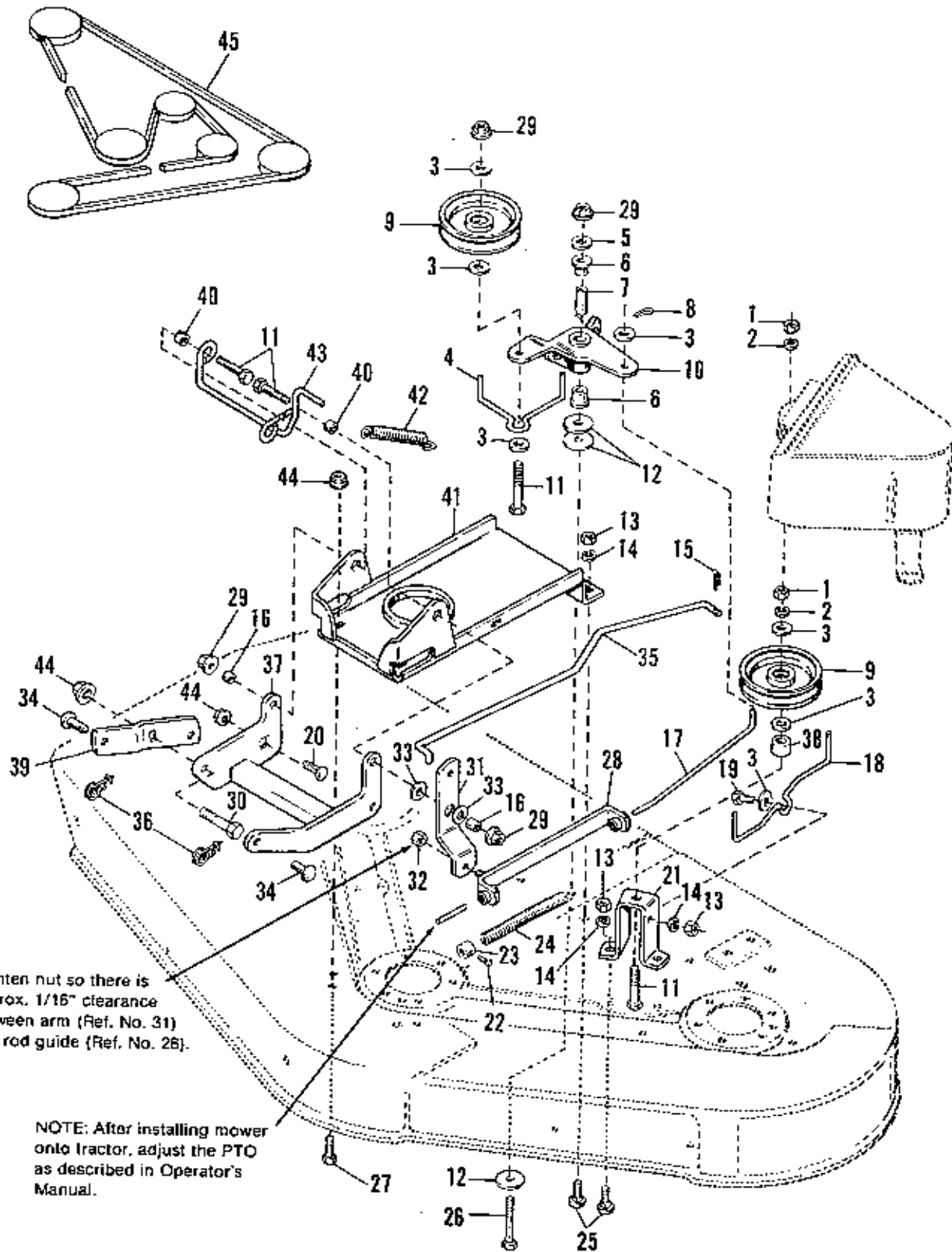

NOTE: Use standard hardware torque spec. chart unless otherwise noted.

Ref. No.	Part No.	Qty.	Description
1	1916950	2	NUT, Hex, 3/8-16
2	1916965	2	LOCKWASHER, 3/8
3	1924940	6	WASHER, Plain
4	1669306	1	STOP, Belt
5	1917378	1	WASHER, Plain, 3/8
6	1663114	2	BUSHING
7	1657242	1	SPACER
8	1918447	1	PIN, Cotter, 3/32 x 3/4
9	171247	2	PULLEY, Idler
10	1703289	1	LEVER ASSY., Clutch
11	1921971	4	CAPSCREW, 3/8-16 x 1-3/4
12	1924356	3	WASHER, Special
13	1917372	5	NUT, Hex, 5/16-18
14	1917356	5	LOCKWASHER, 5/16
15	1918196	1	PIN, Quick, 1-7/8
16	1674440	2	SPACER
17	1668041	1	ROD, Clutch, Mower
18	1669259	1	STOP, Belt
19	1921333	1	CAPSCREW, Hex, 5/16-18 x 1
20	1960135	1	CARRIAGE BOLT, 7/16-14 x 1-1/4
21	1665649	1	SUPPORT, Idler
22	1928804	1	SETSCREW, Sq. Hd., 1/4-20 x 3/8
23	8191022	1	COLLAR, Set
24	1668282	1	SPRING
25	1931333	4	BOLT, Carriage, 5/16-18 x 3/4
26	1928957	1	CAPSCREW, 3/8-16 x 2-3/4
27	1960043	2	BOLT, Whizlock, 7/16-14 UNC x 1"
28	1668278	1	GUIDE ASSY., Rod
29	1930645	4	NUT, Hex, Flange, 3/8-16
30	1920677	1	CAPSCREW, Hex Hd., 7/16-14 x 1-1/4
31	1665624	1	ARM, Pivotal
32	1928698	1	NUT, Jam, Ctr. Lock, 5/16-18
33	1919387	2	WASHER, Plain, 5/8
34	156306	2	PIN
35	1669160	1	ROD, Clutch, Tractor P.T.O.
36	176012	2	PIN, Safety
37	1674443	1	ARM ASSY., Rocker
38	174870	1	SPACER
39	1674441	1	ARM, Rocker
40	118335	2	SPACER
41	1677079	1	SUPPORT ASSY.
42	156302	1	SPRING, Tension
43	1701534	1	ROD, Brake (42")
	1701533	1	ROD, Brake (48")
44	1935041	2	NUT, Flange, Whizlock, 7/16-14
45	1668066	1	V-BELT, Mower Drive (42")
	1703466	1	V-BELT, Mower Drive, Kevlar (48")

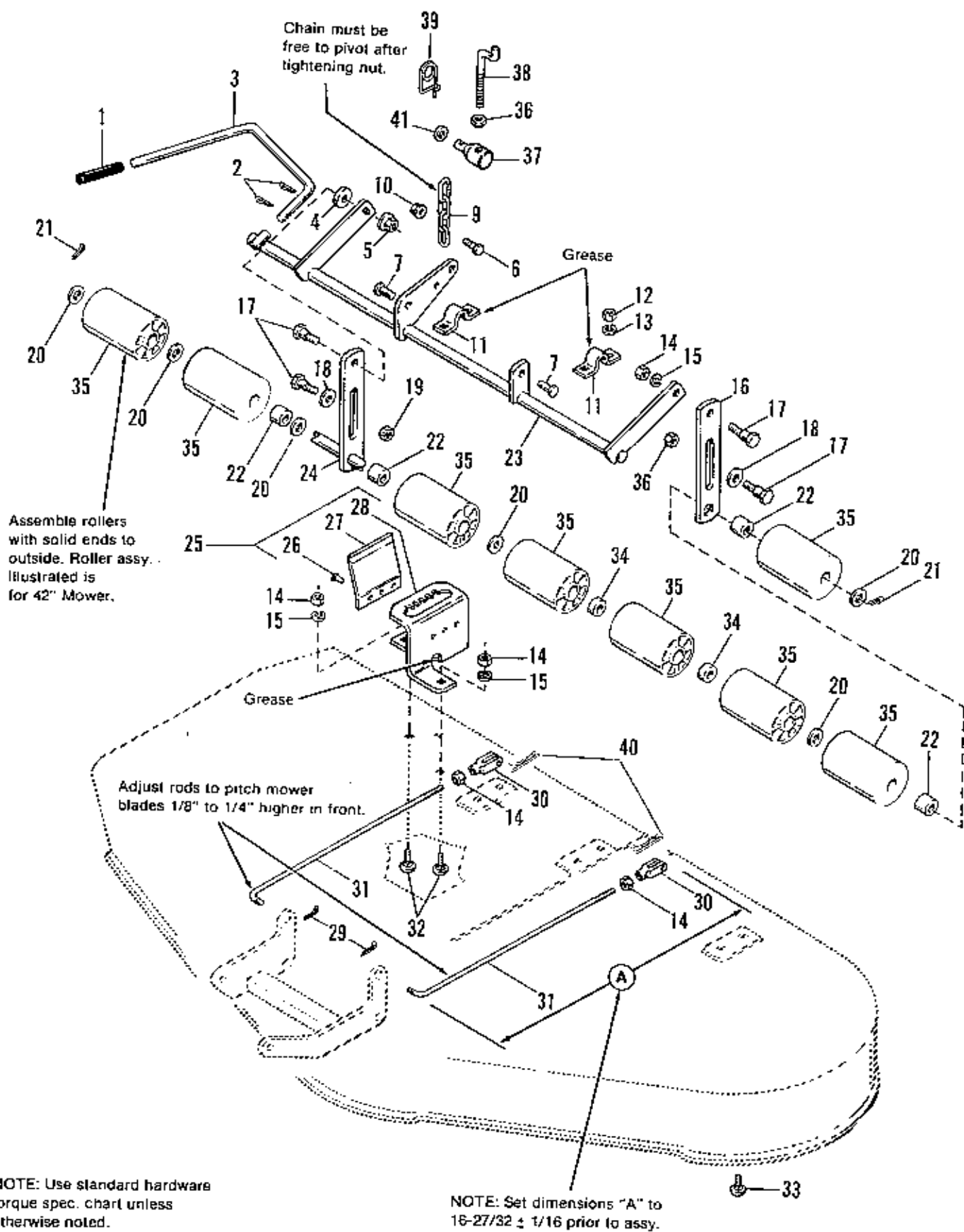

Ref. No.	Part No.	Qty.	Description
1	176933	1	GRIP
2	1918452	2	PIN, Cotter, 1/8 x 1
3	1665864	1	LEVER, Control
4	922755	1	WASHER, Plain, 13/32
5	928352	1	LOCKNUT, Hex, Flange, Whiz, 3/8-16
6	1921333	1	CAPSCREW, Hex, 5/16-18 x 1
7	1923087	2	PIN, Clevis
8	1685247	1	ROD, Lift (Incl. Ref. No. 36, 37, 39 & 41)
9	1669241	1	CHAIN, Lift
10	1935048	1	LOCKNUT, Flange, 5/16-18
11	1665374	2	STRAP (Qty. 3 on 48")
12	1917372	4	NUT, Hex, 5/16-18 (Qty. 6 on 48")
13	1917356	4	LOCKWASHER, 5/16 (Qty. 6 on 48")
14	1916950	6	NUT, Hex, 3/8-16
15	1916965	4	LOCKWASHER, 3/8
16	1603263	1	BAR, Roller
17	1665693	4	BOLT, Shoulder, 3/8-16
18	1924361	2	WASHER, Plain, 1/2
19	1919439	2	NUT, Esna, Lock, 3/8-16
20	1919387	6	WASHER, 25/32 x 1-1/4 (Qty. 9 on 48")
21	1918458	2	PIN, Cotter, 3/16 x 1
22	1602946	4	SPACER (Qty. 5 on 48")
23	1685217	1	ARM ASSY., Mower (42" only)
	1668718	1	ARM ASSY., Mower (48" only)
24	1668814	1	SHAFT ASSY., Roller (42" only)
	1668716	1	SHAFT ASSY., Roller (48" only)
*25	1668828	1	QUADRANT ASSY. (Incl. Ref. Nos. 26, 27 & 28)
26	910542	3	RIVET
27	1663222	1	SPRING
28		1	QUADRANT (Not Serviced Separately) (See Ref. No. 25)
29	1918447	2	PIN, Cotter, 3/32 x 3/4
30	108157	2	CLEVIS, Adj.
31	1685417	2	ROD, Adj.
32	1931348	3	BOLT, Carriage, 3/8-16 x 3/4
33	1934333	4	BOLT, Carriage, 5/16-18 x 3/4 (Qty. 6 on 48")
34	172914	2	SPACER (Used on 42" only)
35	1668513	8	ROLLERS (Qty. 10 on 48")
36	1920161	1	NUT, Jam, 5/16-18
37	172141	1	PIVOT
38	1673665	1	ROD, Lift (Short)
39	176012	1	CLIP, Pin, Safety
40	1980074	2	CLIP, Hair Pin
41	1917642	1	WASHER

*Ref. No. 25 includes Ref Nos. 26, 27 & 28.

A-11045

A-11635

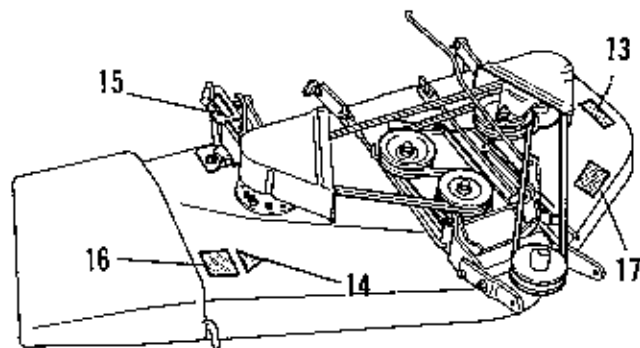
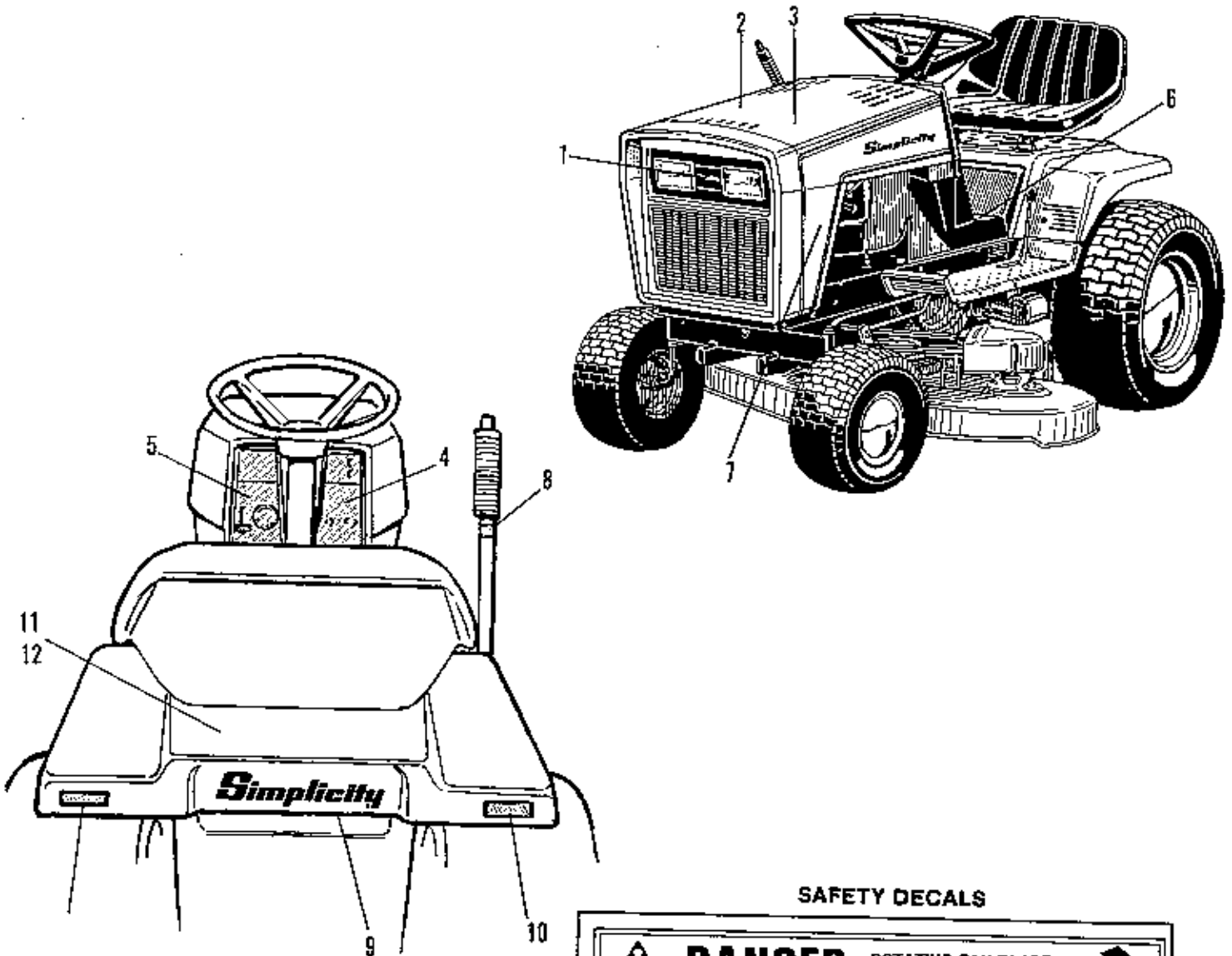

SAFETY DECALS

⚠ DANGER ROTATING FAN BLADE 

Ref. No. 11

⚠ CAUTION

PULLEY GROOVE

1/16" CLEARANCE WITH MOWER ENGAGED

BRAKE PAD

ALWAYS CHECK MOWER BRAKE PAD TO V-PULLEY CLEARANCE WHEN REPLACING BELT OR REPAIRING MOWER. BRAKE PADS WILL BE DAMAGED IF BRAKE PAD CONTACTS PULLEY WHEN MOWER IS ENGAGED.

Ref. No. 17

⚠ DANGER

ROTATING CUTTING BLADE

• DO NOT OPERATE MOWER WITHOUT REFLECTOR OR ENTIRE GRASS CATCHER IN PLACE.

Ref. No. 16

⚠ DANGER

ROTATING CUTTING BLADE

• DO NOT PUT HANDS OR FEET UNDER MOWER DECK WHILE BLADE IS ROTATING.

Ref. No. 13

Ref. No.	Part No.	Qty.	Description
1	1701198	1	DECAL, Grille
2	1703585	1	DECAL, Hood Stripe, R.H. (12.5 HP)
	1703587	1	DECAL, Hood Stripe, R.H. (16 HP)
	1703639	1	DECAL, Hood Stripe, R.H. (17 HP)
3	1701602	1	DECAL, Drive Belts (1691253, 1691468)
	1703644	1	DECAL, Drive Belts (1691736)
4	1669357	1	DECAL, Dash, R.H.
5	1701603	1	DECAL, Dash, L.H.
6	1702421	1	DECAL, Shift Pattern
7	1703584	1	DECAL, Hood Stripe, L.H. (12.5 HP)
	1703586	1	DECAL, Hood Stripe, L.H. (16 HP)
	1703638	1	DECAL, Hood Stripe, L.H. (17 HP)
8	175216	1	DECAL, Lift Lever
9	1668202	1	DECAL, "Simplicity"
10	1701600	2	REFLECTOR, Rear
11	1701270	1	DECAL, Warning, Fan (Under Seat Deck)
12	1702637	1	DECAL, Release Valve (Under Seat Deck)
13	1676921	1	DECAL, Danger
14			DECAL, OPEI, (Not Serviced)
15	1656855	1	DECAL, Mower Height
16	1676922	1	DECAL, Danger
17	1702114	1	DECAL, Caution, Blade Brake

Hardware Identification & Torque Specifications

Common Hardware Types

Hex Head Capscrew



Washer

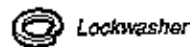

Lockwasher

Carriage Bolt



Hex Nut

Standard Hardware Sizing

When a washer or nut is identified as 1/2", this is the *Nominal size*, meaning the *inside diameter* is 1/2 inch; if a second number is present it represents the *threads per inch*.

When bolt or capscrew is identified as 1/2 - 16 x 2", this means the *Nominal size*, or *body diameter* is 1/2 inch; the second number represents the *threads per inch* (16 in this example, and the final number is the *body length* of the bolt or screw (in this example 2 inches long).

The guides and ruler furnished below are designed to help you select the appropriate hardware and tools.

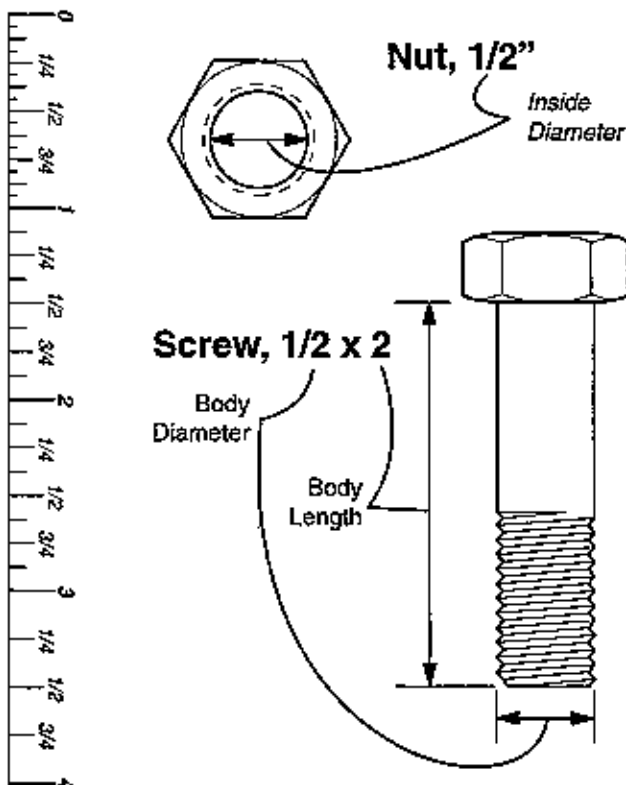

Torque Specification Chart						
FOR STANDARD MACHINE HARDWARE (Tolerance ± 20%)						
Hardware Grade	No Marks SAE Grade 2		SAE Grade 5		SAE Grade 8	
	in/lbs ft/lbs	Nm.	in/lbs ft/lbs	Nm.	in/lbs ft/lbs	Nm.
8-32	19	2.1	30	3.4	41	4.6
8-36	20	2.3	31	3.5	43	4.9
10-24	27	3.1	43	4.9	60	6.8
10-32	31	3.5	49	5.5	68	7.7
1/4-20	66	7.6	8	10.9	12	16.3
1/4-28	76	8.6	10	13.6	14	19.0
5/16-18	11	15.0	17	23.1	25	34.0
5/16-24	12	16.3	19	25.8	27	34.0
3/8-16	20	27.2	30	40.8	45	61.2
3/8-24	23	31.3	35	47.6	50	68.0
7/16-14	30	40.8	50	68.0	70	95.2
7/16-20	35	47.6	55	74.8	80	108.8
1/2-13	59	68.0	75	102.0	110	149.6
1/2-20	55	74.8	90	122.4	120	163.2
9/16-12	65	88.4	110	149.6	150	204.0
9/16-18	75	102.0	120	163.2	170	231.2
5/8-11	90	122.4	150	204.0	220	299.2
5/8-18	100	136	180	244.8	240	326.4
3/4-10	160	217.6	260	353.6	386	525.0
3/4-16	180	244.8	300	408.0	420	571.2
7/8-9	140	190.4	400	544.0	600	816.0
7/8-14	155	210.8	440	598.4	660	897.6
1-8	220	299.2	580	788.8	900	1,244.0
1-12	240	326.4	640	870.4	1,000	1,360.0

NOTES

- These torque values are to be used for all hardware excluding: locknuts, self-tapping screws, thread forming screws, sheet metal screws and socket head setscrews.
- Recommended seating torque values for locknuts:
 - for prevailing torque locknuts - use 65% of grade 5 torques.
 - for flange whizlock nuts and screws - use 135% of grade 5 torques.
- Unless otherwise noted on assembly drawings, all torque values must meet this specification.

Wrench & Fastener Size Guide



1/4" Bolt or Nut
Wrench—7/16"



5/16" Bolt or Nut
Wrench—1/2"

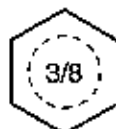

3/8" Bolt or Nut
Wrench—9/16"



7/16" Bolt or Nut
Wrench (Bolt)—5/8"
Wrench (Nut)—11/16"

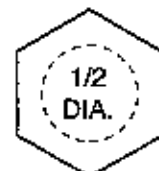

1/2" Bolt or Nut
Wrench—3/4"

SIMPLICITY MANUFACTURING, INC.
500 N. Spring St., P.O. Box 997
Port Washington, WI USA 53074-0997

© 1988 Simplicity Manufacturing, Inc.
All Rights Reserved.