

OPERATOR'S MANUAL

Walk-Behind Mowers 4 HP, 21" Cut with Rear Bagger

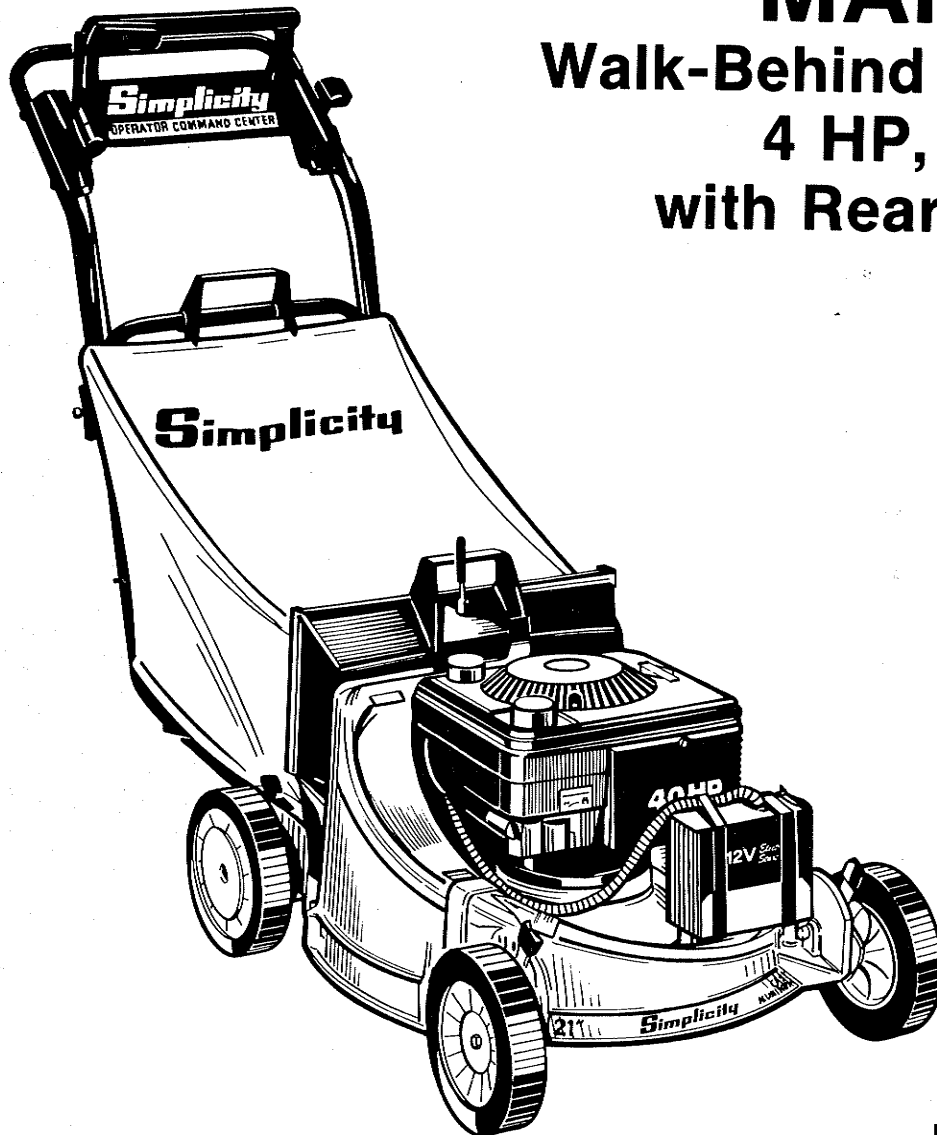

FORM - 1612437
PRINTED IN U.S.A.
2/89

MODEL 1550ZS
MFG. NO. 1691727

MODEL 1550ES
MFG. NO. 1691729

Simplicity®

BASIC SAFETY PRECAUTIONS

TRAINING

- Read the operating and service instruction manual carefully. Be thoroughly familiar with the controls and the proper use of the equipment.
- Never allow children to operate a power mower.
- Keep the area of operation clear of all persons, particularly small children, and pets.

PREPARATION

- Thoroughly inspect the area where the equipment is to be used and remove all stones, sticks, wires, bones, and other foreign objects.
- Do not operate the equipment when barefoot or wearing open sandals. Always wear substantial footwear.
- Check the fuel before starting the engine. Do not fill the gasoline tank indoors, when the engine is running, or until the engine has been allowed to cool for several minutes after running. Clean off any spilled gasoline before starting the engine.
- Disengage the self-propelled mechanism or drive clutch on units so equipped before starting the engine (motor).
- Never attempt to make a wheel height adjustment while the engine (motor) is running.
- Mow only in daylight or in good artificial light.
- Never operate the equipment in wet grass. Always be sure of your footing; keep a firm hold on the handle and walk; never run.

OPERATION

- Do not change the engine governor settings or over-speed the engine.
- Do not put hands or feet near or under rotating parts. Keep clear of the discharge opening at all times.
- Stop the blade (s) when crossing gravel drives, walks, or roads.
- After striking a foreign object, stop the engine (motor), remove the wire from the spark plug, thoroughly inspect the mower for any damage, and repair the damage before restarting and operating the mower.
- If the equipment should start to vibrate abnormally, stop the engine (motor) and check immediately for the cause. Vibration is generally a warning of trouble.

- Stop the engine (motor) whenever you leave the equipment, before cleaning the mower housing, and when making any repairs or inspections.
- When cleaning, repairing, or inspecting, make certain the blade and all moving parts have stopped. Disconnect the spark plug wire, and keep the wire away from the plug to prevent accidental starting.
- Do not run the engine indoors.
- Shut the engine (motor) off and wait until the blade comes to a complete stop before removing the grass catcher or unclogging chute.
- Mow across the face of slopes; never up and down. Exercise extreme caution when changing direction on slopes. Do not mow excessively steep slopes.
- Always disconnect electric mowers (line operated) before cleaning, repairing, or adjusting.
- Never operate the mower without proper guards, plates, or other safety protective devices in place.
- Keep washout ports and other mower-housing service openings closed when mowing.

MAINTENANCE AND STORAGE

- Check the blade and the engine mounting bolts at frequent intervals for proper tightness.
- The cutting edges of the mower blade are sharp and can lacerate (cut) skin tissue. Care should be taken when doing any repair work on or around the mower blade. To prevent injury, it is recommended that gloves be worn or the cutting edge be wrapped with newspaper or any other suitable material when working on the blade.
- Keep all nuts, bolts and screws tight to be sure the equipment is in safe working condition.
- Never store the equipment with gasoline in the tank inside a building where fumes may reach an open flame or spark. Allow the engine to cool before storing in any enclosures.
- To reduce fire hazard, keep the engine free of grass, leaves, or excessive grease.
- Check the bag frequently for deterioration and wear and replace worn bags. Check that replacement bags comply with original manufacturer's recommendations or specifications.

CONTENTS

Basic Safety Precautions	2	Operating Instructions	8
Information for the Purchaser	3	Safe Mowing Practices	9
Safety Definitions.....	3	Maintenance and Adjustment	10
Set-Up Instructions.....	4	Lubrication	13
Operating Controls	6	Storage.....	14
Starting and Stopping	7	Troubleshooting.....	15

INFORMATION FOR THE PURCHASER

MOWER OPERATOR'S MANUAL

Please read this manual thoroughly before proceeding with assembly. To avoid possible damage, such as crimping the control cables, it is necessary to unpack and assemble the unit per our instructions.

While unpacking the mower, inspect for shipping damage. If you find any damage, notify the store or dealer who sold you the mower.

This operator's manual gives instructions for unpacking and initial assembly, operation and care of the mower. Detailed instructions for maintenance and adjustment are limited to things a user may be expected to perform. For services which, if inexpertly performed, might lead to unit damage or unsafe performance, we recommend an authorized servicing dealer. He has the experience and the genuine factory service parts to do the work.

Descriptions and illustrations are as accurate as possible at the time of publication. Illustrations may include optional equipment or accessories and may not show all models covered by this literature.

SEPARATE ENGINE MANUAL SUPPLIED

In addition to the mower operator's manual you are now reading, an operating and maintenance manual is supplied for the 4-cycle engine. The engine manual covers engine safety, starting, maintenance and adjustment.

WARRANTY INFORMATION

The limited warranty packed with your mower will give the length of time, and conditions under which your machine is warranted.

A serial number plate is located at the rear of the mower deck below the grass catcher door. Record these identification numbers and use them in any correspondence or phone contacts you may have with your authorized servicing dealer or our Manager of Customer Relations.

SAFETY DEFINITIONS



DANGER

The signal word "DANGER" signifies that a source of extreme danger to a person on or near a machine exists as a result of the very nature of the machine itself. This danger to persons is such that it would result in a high likelihood of death or permanent injury if the recommended precautions are not taken.



WARNING

The signal word "WARNING" indicates that a source of danger to a person on or near a machine exists which may result in death or injury if the recommended precautions are not taken.

SET-UP INSTRUCTIONS

NOTE

Directions (front, rear, left, right, etc.) in this manual are oriented from the operator's position behind the control handles.

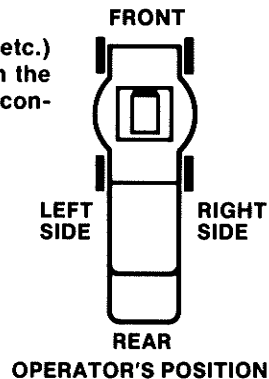

- c) Press inward on both handle ends to clear stops on deck. Push down on lower handle until the flat portions snap into place below the cast stops in the mower deck.

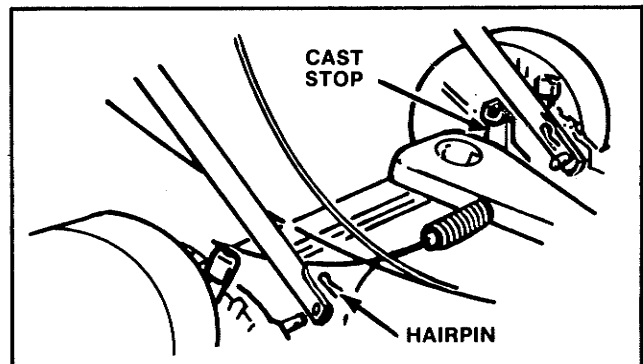

FIGURE 2

UNPACKING

To prevent pulling and kinking of the control cables, be sure to unpack as instructed below, and not try to lift the mower out of the carton.

1. Place the carton on a large clear work space.
2. Slit all four corners and lay the sides flat on the work space.
3. Remove protective packing, the grass bag and the bag of small parts.
4. Lay aside the lower handle. Lay the upper handle straight back from the machine so the cables are not bent.

- d) Install the hairpin retainers in the holes in the right and left pins.

3. Take two of each of the following from the bag of parts: joining bolt, joining knob, and hex nut. Select the height desired for the upper handle (see Figure 1) and push a joining bolt through the holes on the left side of the handles. (See Figure 3).

ASSEMBLING HANDLES TO DECK

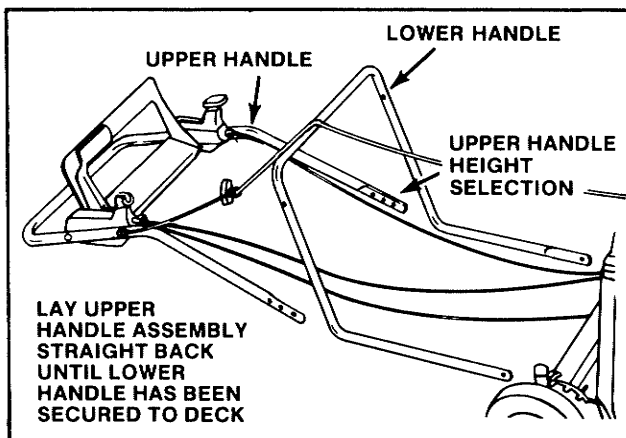

FIGURE 1

1. Lay the upper handle straight back from the mower so as not to pull or crimp the control cables. Lay the cables between the sides of the handles so they will go under the crossbar of the lower handle when the handles are put together. (See Figure 1.)

NOTE

When installing the lower handle on the manual start model, put the starter rope outside the handle and slide it up over the handle crossbar.

2. Installing the lower handle:
 - a) Install the right side of the handle on the right side pin at the rear of the mower deck.
 - b) Push the left side handle toward the right until it can be installed on the left pin at the rear of the mower deck. Locate cable above pin and inside handle.

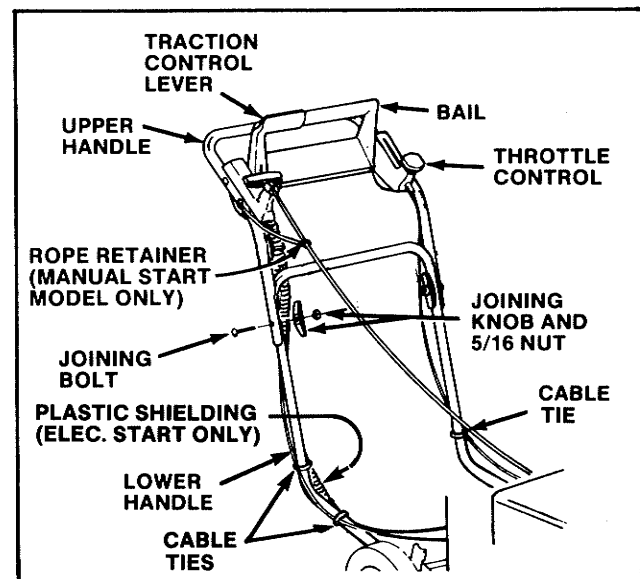

FIGURE 3

4. Push the other bolt through the holes on right side of the handles. Put a joining knob and hex nut on each bolt. Thread the nut and knob together until the two handles are locked in position.

- Route throttle cable down left side of handle as shown. Install one cable tie on handle above curved section and one below curved section.

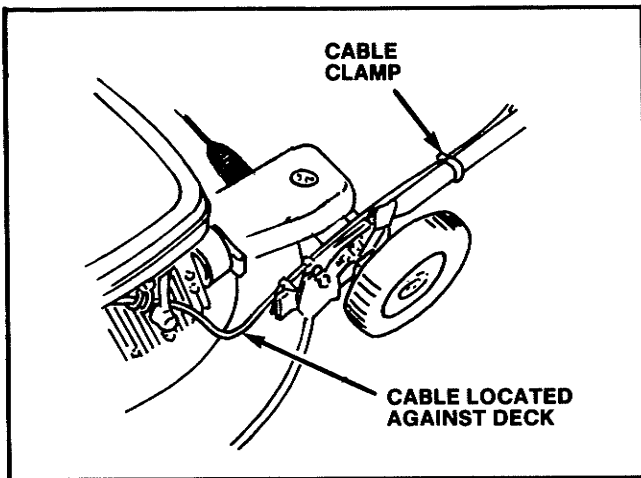

FIGURE 4

- Route traction control cable and engine control cable (inside plastic shielding on electric start model) down right side of handle as shown in Figure 3. Install one cable tie on handle above curved section and one below curved section.

MOUNTING THE BAG ADAPTER AND GRASS CATCHER

The assembly comes ready for mounting.

- Hold the bag handle and the adapter handle in the same hand. (Figure 5.)
- Open the discharge door on the mower with your other hand. (Figure 5.)

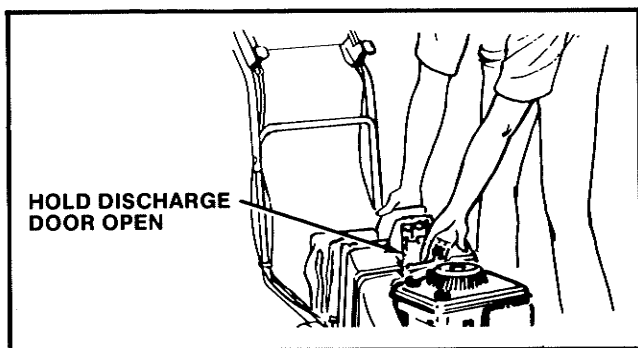

FIGURE 5

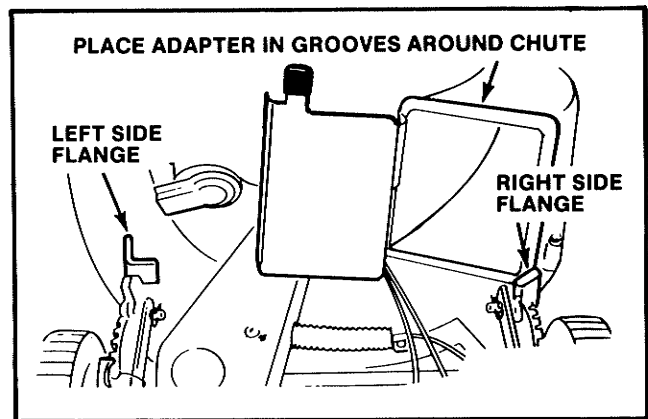

FIGURE 6

- Place the bag adapter over the grooves in the discharge chute. Slide adapter down until the adapter bottoms in the flanges on the mower deck. (Figure 6.)
- Make sure the adapter bottoms in the groove of the chute then release the door to secure assembly. If the adapter will not bottom in the grooves, check for grass build-up in the flanges and clean them if necessary.

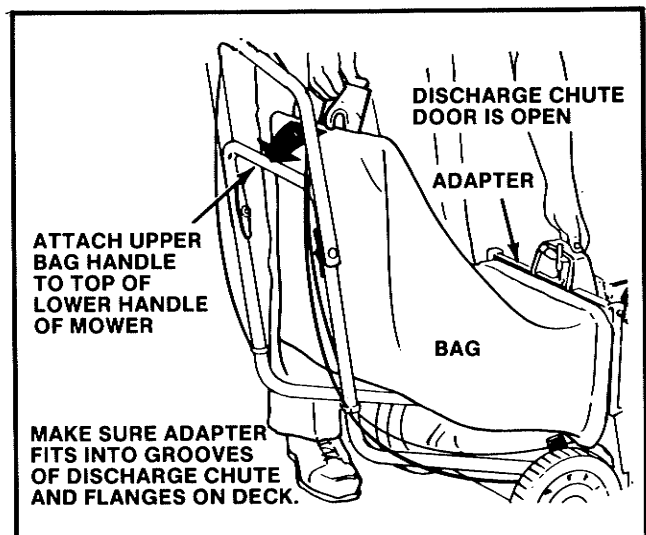

FIGURE 7

- Hook the bag handle over the crossbar of the mower's lower handle. (Figure 7.)



DANGER

To avoid the possibility of serious bodily injury, stop the engine before installing or removing the catcher. DO NOT reach into the discharge chute when engine is running. Remove and install catcher with care. Never operate the mower if the entire grass catcher or discharge chute is not in place.

OPERATING CONTROLS

THROTTLE CONTROL LEVER (See Figure 8)

The throttle control on the left side of the upper handle controls only engine speed and has nothing to do with stopping the engine (which is done by releasing the bail). A decal on the throttle control indicates the IDLE-RUN-CHOKE range of speed settings. For starting a cold engine, the control lever should be set in the CHOKE position. A warm engine can be started at slower speeds. The mower must be operated at full throttle (RUN position) to ensure proper battery charging (electric start models) and maximum bagging performance.

BAIL (ENGINE CONTROL BAR) (See Figure 8)

The primary purpose of this control is to *permit* and *stop* engine operation. For this purpose, a "bail" (engine control bar) is provided. When this bail is depressed against the handle crossbar, the engine can operate. When the engine is operating, releasing the bail must stop the engine within 3 seconds in accordance with current specifications of the Consumer Products Safety Commission.

According to the features of the particular model, additional functions are illustrated below. These added functions include *button* for electric start models, and *traction control lever* for power-propelled models.

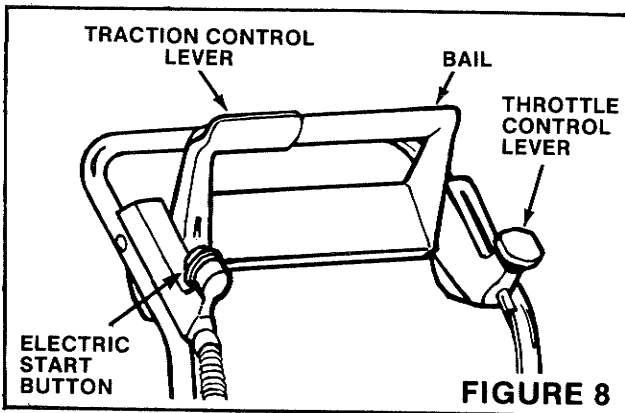

ELECTRIC START BUTTON (See Figure 9)

The electric start switch is a push button device located on the right side of the handle. When the button is pushed it activates the starter motor. The bail must be depressed against the handle for the push button to engage.

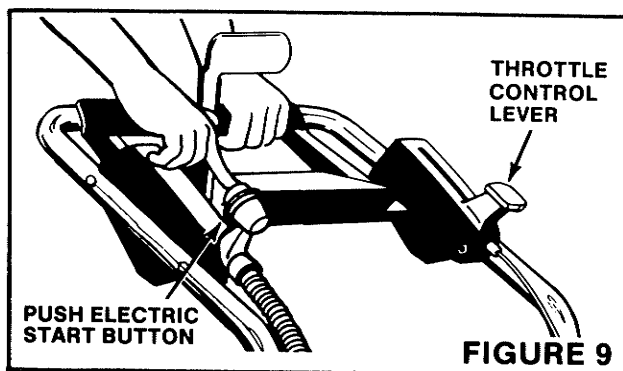

TRACTION CONTROL OF POWER-PROPELLED MODELS (See Figure 10)

When the traction drive is engaged the rear wheels propel the mower forward. Engagement is accomplished by holding the *traction control lever* (on right side of bail) depressed against the bail and handle. You should know the following about your power-propelled mower:

1. During starting only the bail should be depressed. Depressing the traction control lever during starting would make it hard to crank a rope start model, and would throw an extra load on an electric starter motor.

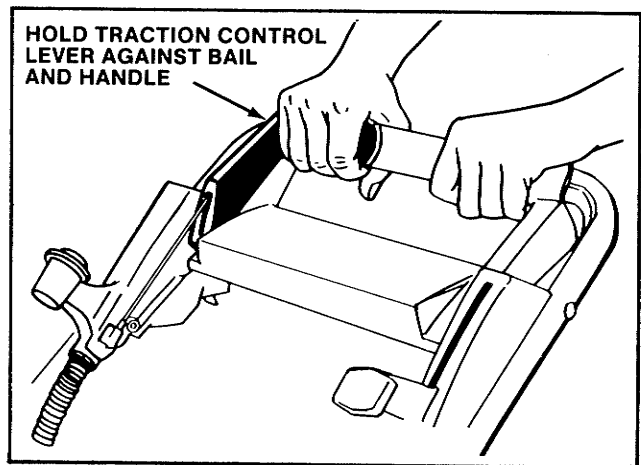

FIGURE 10

2. The traction drive of the new mower should be checked before engine start-up, both for proper engagement and proper disengagement. If the drive does not perform as follows, it should be adjusted. (See TRACTION DRIVE ADJUSTMENT page 11.)
 - a) With engine not running, and *traction control lever* not depressed, pull mower backwards to see that the rear wheels turn.
 - b) With engine not running, hold *traction control lever* against handle and pull mower backwards to determine that the rear wheels have been engaged and will not turn.

NOTE

Parts wear and cable stretch may change the performance so that the clutch will slip more than when new. Slipping will first be noticed when mowing in tall or tough grass or on hills. Your authorized servicing dealer can adjust for slippage, or you can follow instructions in the maintenance section to make the adjustment whenever required.



WARNING

For safe operation, the traction drive must disengage immediately when the *traction control lever* is released. If it does not, have the machine properly serviced.

TRAVEL SPEED

The power-propelled model is equipped with two pulleys allowing two ground speeds of the machine. With the belt on the small engine pulley the ground speed is 2.4 mph and with the belt on the large pulley the ground speed is 2.7 mph. To change speeds see CHANGING GROUND SPEED, page 11.

FUEL SHUT-OFF VALVE

The fuel shut off valve is located at the right front of the engine on the fuel tank. It has two positions—OPEN and CLOSED.

PRE-STARTING CHECK LIST

1. Check that the mower is in good operating condition, with handle sections tightened securely.
2. Check that underside of deck is clean and the blade is unobstructed.
3. Be sure the blade is in good condition. (See "Examining the Blade.")
4. Check that the bag adapter and grass bag are properly attached. (See "Set-Up Instructions.")
5. Adjust to the desired cutting height. (See "Maintenance and Adjustments.")
6. Put mower on a clear level surface such as a concrete drive (not on high grass or gravel surfaces).
7. Remove the fill plug (see Figure 11) and fill crankcase with engine oil up to full mark on dipstick. See engine manual for recommended type of oil. Do not overfill crankcase.
8. Electric start models - connect the battery. The battery of a new mower is not fully charged. If it does not crank the engine, see BATTERY CHARGING, page 12.
9. Fill the engine tank with clean, fresh regular grade automotive gasoline. DO NOT MIX ANY OIL WITH GASOLINE because this is a 4-cycle engine.
10. Open fuel shut off valve.

SEE ENGINE MANUAL FOR ENGINE OIL RECOMMENDATIONS. FILL CRANKCASE WITH OIL UP TO LEVEL OF FULL MARK ON DIPSTICK.

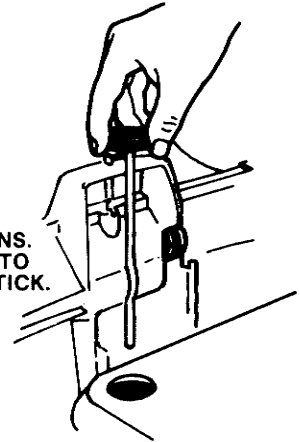

FIGURE 11

STARTING AND STOPPING



DANGER

To avoid the possibility of serious bodily injury, keep hands and feet away from the deck and blade before and after starting the engine. Do not tie the bail in the operating position or tamper with the operating controls provided for your protection. Keep children out of the area while you are using the mower.

1. Open fuel valve.
2. Move the throttle control lever to the CHOKE position.
3. Hold bail against handle.
4. **Manual Start Models (see Figure 12):**
Grasp the starter grip and pull slowly until starter engages. Then pull cord rapidly to overcome compression, prevent kickback and start engine. Repeat if necessary with throttle in the "RUN" position until engine starts.
5. **Electric Start Models (see Figure 13):**
Depress start button on engine control to start engine (see Figure 13). Push button in short intervals of a few seconds. Release button when engine starts. Never crank more than 10 seconds at a time.

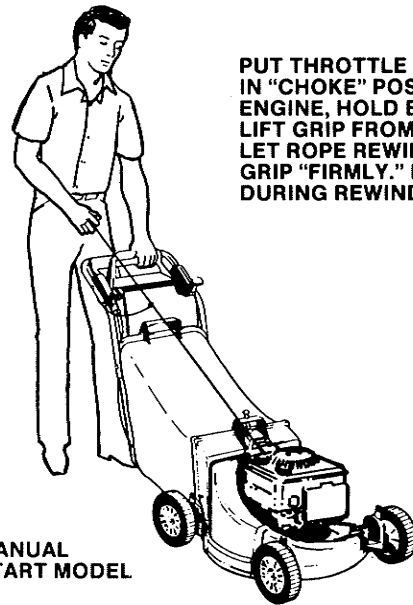

PUT THROTTLE CONTROL LEVER IN "CHOKE" POSITION. TO CRANK ENGINE, HOLD BAIL DEPRESSED, LIFT GRIP FROM HOLDER AND LET ROPE REWIND. THEN PULL GRIP "FIRMLY." HOLD GRIP DURING REWINDING.

MANUAL START MODEL

FIGURE 12

6. Allow the engine to warm up.
7. If equipped, engage the traction drive by holding the traction control lever against the bail and handle. (See Fig. 10.)

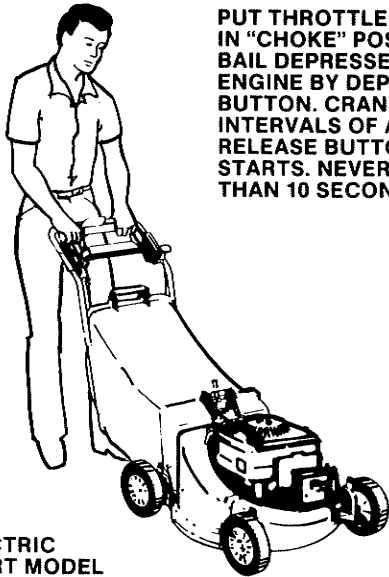

PUT THROTTLE CONTROL LEVER IN "CHOKE" POSITION. HOLD BAIL DEPRESSED THEN CRANK ENGINE BY DEPRESSING START BUTTON. CRANK IN SHORT INTERVALS OF A FEW SECONDS. RELEASE BUTTON WHEN ENGINE STARTS. NEVER CRANK MORE THAN 10 SECONDS AT A TIME.

ELECTRIC START MODEL

FIGURE 13

To Stop:

- a) Release the traction drive control. Forward motion stops.
- b) Pull throttle back from operating position to "IDLE."
- c) Release the bail (engine will stop).

AUXILIARY STARTING

A recoil starter is provided for use if the electric start system should fail to work properly. This starter should be used as an auxiliary starter only and not as a regular means of starting. Caution should be taken when using the auxiliary starter since the potential hazard of inadvertently allowing the foot to get under the mower deck exist when the operator is removed from the normal operating position. The electric starter should be repaired so that starting can be done from the normal operating position.

! WARNING

To avoid the possibility of a potential fire hazard, inspect the electric start system for a short circuit or a loose or broken wire. **DO NOT** start the unit if either of these conditions exist. Have the unit repaired by an authorized servicing dealer.

- 1. Open fuel valve.
- 2. Move throttle control lever to the CHOKE position.
- 3. Hold bail against handle with right hand.
- 4. Place left foot on deck approximately center between the front and rear wheels.

CAUTION

Avoid placing left foot in the area of the hot muffler and exhaust. Be sure right foot is clear of mower.

- 5. Grasp starter grip with left hand. Pull slowly until starter engages then pull rapidly to overcome engine compression, prevent kickback, and start engine. Repeat if necessary with throttle in RUN position until engine starts.
- 6. Immediately return to operator's position when engine starts.

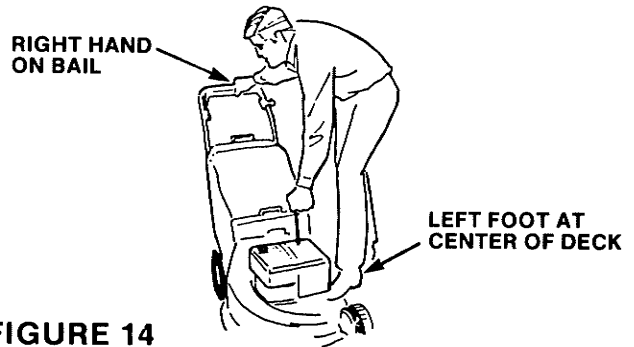

FIGURE 14

OPERATING INSTRUCTIONS

! WARNING

For safe operation, traction drive of power-propelled models must disengage immediately. If it does not, have the machine serviced before further use.

OVERLAPPING THE RUNS

To achieve the necessary overlap, but avoid extra wheel traces across your lawn, run the inside of the front wheel along the edge of uncut grass.

CUTTING HEAVY GRASS

Operate at RUN throttle setting. If clogging occurs reduce width of the cut, or raise cutting height of mower, or push the mower more slowly than normal.

SAFE MOWING PRACTICES

MOWING PATTERNS

If the mowing pattern and direction of progress are changed each time you mow, it will help eliminate matting, graining and corrugation, thereby enhancing the appearance of your lawn. Instead of cutting circles, try the various mowing patterns shown.

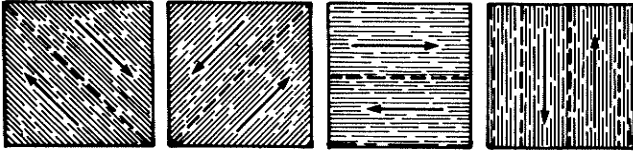

FIGURE 15

USING GRASS CATCHER WITH MOWER

Cut only when grass is dry to obtain the best lawn appearance and catch most of the clippings. Wet grass may clog the mower and the bag.

If you miss a mowing or two and the grass has grown very high, it is good to cut the lawn in two mowings — the first at a high setting and the next at the desired height. This gives a smooth finish and you will also catch more clippings in the catcher.

The rule of thumb is to cut no more than 1/3 the grass blade height in a single cutting and never more than 2 inches (51 mm) of the grass in one cutting. This prevents clumping and clogging, and also yellowing of the lawn.

Do not use mower without grass catcher unless optional side discharge accessory is used.

EMPTYING BAG AND UNCLOGGING CHUTE



WARNING

If the chute clogs, release the bail and wait until the engine stops. Then disconnect the spark plug wire. Never try to unclog the mower if the engine is running or even capable of being inadvertently started.

1. Remove bag and adapter. Place the adapter over receptacle or mulch pile. Push latch release on top of adapter. Bag will swing back and empty when upper bag handle is lifted.
2. Open discharge chute door and clean the chute. Be very careful — blade is directly below chute opening. Close door and bounce the rear of the deck on the ground to dislodge grass under the mower deck.
3. Install adapter and bag (see "Set-Up Instructions") and reconnect the spark plug wire before starting the engine.

HILLSIDE MOWING

Always be sure the crankcase is completely full (up to the full mark) with oil, because this is absolutely necessary when the engine is operated on a tilt.

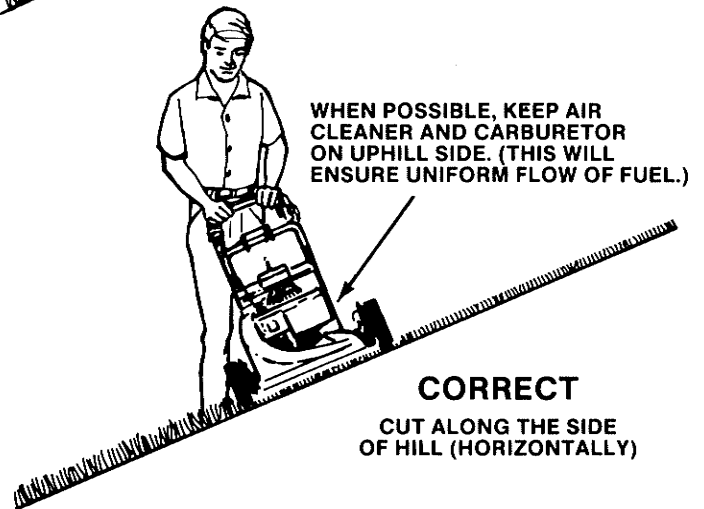
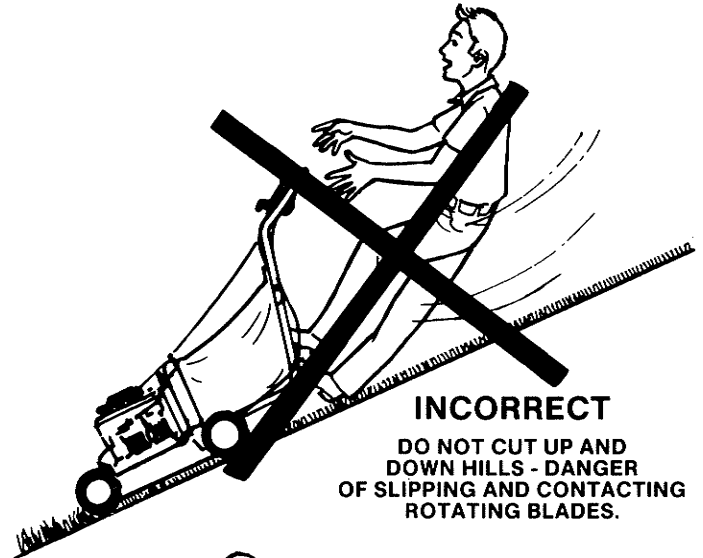

FIGURE 16



DANGER

The least dangerous method of mowing hilly terrain is to cut along the side horizontally instead of up and down the slope. This will keep the mower away from your body in the event you slip. It will also help to reduce scalping the crown of a hill. Use extreme caution to avoid slipping and loss of balance. Because of the increased danger of slipping, never mow when the grass is wet or damp. Always wear adequate footwear.

MAINTENANCE AND ADJUSTMENT

⚠ WARNING

To avoid the possibility of serious bodily injury, disconnect the spark plug wire to prevent accidental starting, before you perform any of the maintenance or adjustments given in this section. On electric start models disconnect battery from starter motor.

CARE OF GRASS BAG

Under normal usage the bag material is subject to deterioration and wear. Check regularly and obtain replacement bags from your dealer as necessary. If washing of the bag is desired, we suggest hand or hose-rinsing, or overnight soaking in a suitable container. After using the catcher, store it in an airy location to prevent mildew.

EXAMINING THE BLADE (See Figures 17 and 18)

⚠ WARNING

To avoid the possibility of accidental engine start-up and resulting serious bodily injury, disconnect spark plug wire before you begin any work on the blade or underside of the deck. Before turning deck on its side empty the fuel tank.

Before each use, examine the blade to be sure it is in good condition. Lay the mower on its right side and check as follows:

1. Check that the blade is straight and not bent out of line as shown in Figure 17. Striking objects (such as survey stakes or curbing) hard enough to bend the blade can cause microscopic cracks in the hardened steel. These tiny cracks will grow. Pieces breaking off cracked blade tips become projectiles which can cause serious bodily injury to anyone in their path. Replace cracked blade immediately.

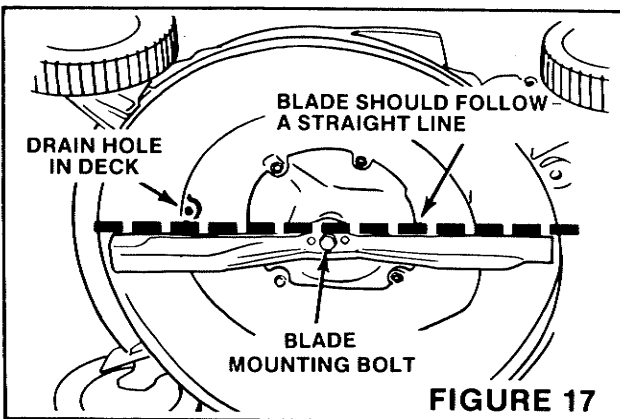

2. Abrasive soils and saw grass can cause blade wear at the base of the flukes (the bent-up tips of the blade). As displayed in Figure 18, wear causes cracks to develop as in "A" and to deepen as in "B." Replace cracked blade before wear gets to the dangerous "B" stage.

IMPORTANT

After the mower has been turned over or tipped up for any reason **DO NOT TRY TO START ENGINE** before letting it set upright at least 3 minutes, while the oil is draining from the cylinder back into the crankcase. After this time, remove and dry off the spark plug. Then crank the engine several times to purge any oil remaining in the cylinder. Reinstall the spark plug and start the engine.

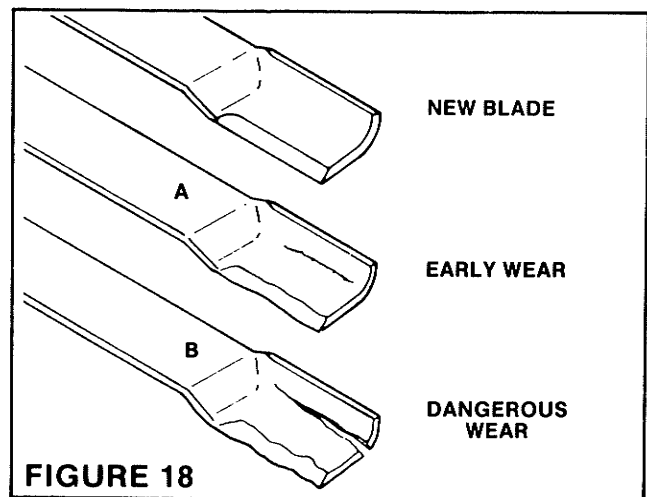

FIGURE 18

CHANGING THE BLADE (See Figure 17)

1. Tip forward and drain fuel into a suitable receptacle. Disconnect spark plug wire.
2. Turn mower over on its right side.
3. To lock blade from turning, place screwdriver shaft in drain hole at front, center of deck. Remove the blade bolt and lockwasher and the blade.
4. To install blade, put in place and hold with the lockwasher and blade bolt. Again use screwdriver in hole to hold from turning. Tighten bolt securely (35-40 ft. lbs., or 47-54 Nm).
5. Put mower back on its wheels. Reconnect spark plug wire.

SHARPENING BLADE

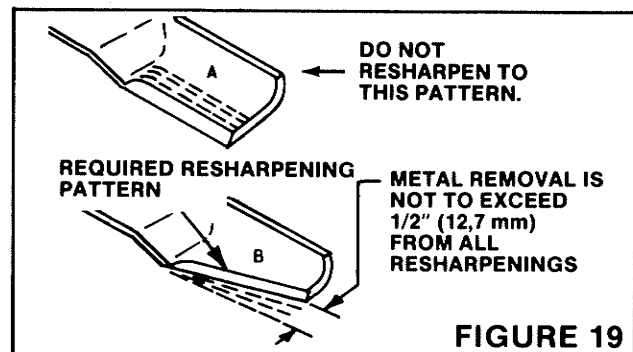

FIGURE 19

NOTE

When dressing or sharpening the blade, **DO NOT** follow the original angle of grind as shown in "A," Figure 19. Instead, grind new cutting edges on a diagonal as shown in "B." Some metal will be lost each time. The total loss, measured at tip of blade in "B" of Figure 19 should not exceed 1/2". Make sure that each cutting edge receives an equal amount of grinding to prevent having an unbalanced blade which will vibrate excessively at high speeds and may damage the mower.



DANGER

Incorrect sharpening of the blade beyond the amount displayed in "B" of Figure 19 increases the possibility that a sudden impact could break the tip off the blade. The broken piece discharged from under the mower at high speed could cause serious bodily injury.

BLADE BALANCING INSTRUCTIONS

Check balance of blade by supporting blade at center hole with a nail or round screwdriver clamped in a vise. If either end of the blade rotates downward, grind or file material from the end—not the leading edge of the blade. The blade is properly balanced when neither end drops.

CENTER HOLE

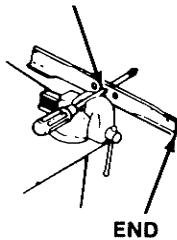

CHANGING GROUND SPEED

The power-propelled models are equipped with two pulleys on the engine crankshaft allowing a fast (2.7 mph) and a slow (2.4 mph) ground speed. The large pulley is for "fast speed" and the small pulley for "slow speed." To change ground speed:

1. Disconnect the spark plug wire from the spark plug.
2. Remove the bolt holding the belt cover to the mounting strap on the mower deck. Then slide out the cover.
3. Slip the belt over and off the gear reducer pulley.
4. Look into the slot in the mower deck and install the belt in the desired pulley groove. Large pulley for "fast speed," and small pulley for "slow speed."
5. Rotate the gear reducer against the spring force by pushing down on the lever.

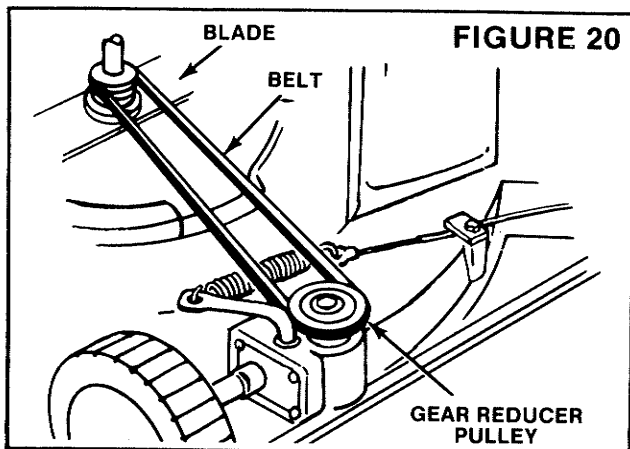

6. Install the belt on the gear reducer pulley and release the gear reducer. Check to be sure the belt is seated in the desired pulley groove on the engine and properly seated in the gear reducer pulley.
7. Install the belt cover and secure with the bolt.

BELT REPLACEMENT

Replacement belts are available from your authorized servicing dealer. Follow the procedure given below.

1. Disconnect spark plug wire from the spark plug.
2. Remove the bolt holding the belt cover to mounting strap on deck. Then slide out the cover.
3. Slip the belt over and off the gear reducer pulley.
4. Tip the mower on its right side, letting it rest on its handles.

CAUTION

Do this procedure with less than 1/4 tank of gasoline and the oil dipstick must be tight.

5. Pull the belt through slot in deck so that entire belt is under deck.
6. Slip belt over end of blade and remove.
7. Reverse the above procedure to install new belt.

TRACTION DRIVE ADJUSTMENT

The following steps may be taken to achieve the proper adjustment:

1. Disconnect the spark plug wire.
2. Unscrew cable clamp from the mower deck.
3. Lift cable from the slot in the mower deck and move it to the right until the slack is removed from the cable.
4. Put cable in slot and install cable clamp.
5. Tighten cable clamp screw.
6. Install spark plug wire on spark plug.
7. Test drive adjustment. If mower drive does not release, readjust adding slack to the system.

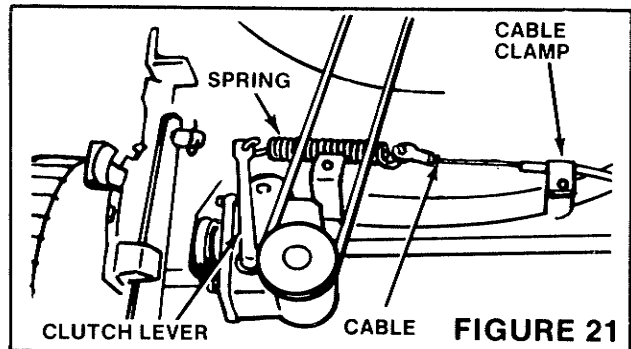

THROTTLE CONTROL ADJUSTMENT

Remove air cleaner. Move speed control lever to CHOKE position. The carburetor choke should be closed as illustrated.

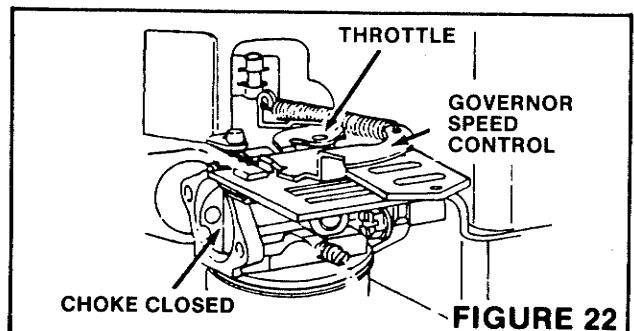

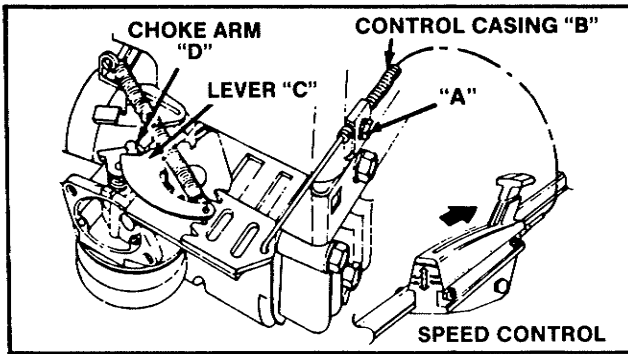

FIGURE 23

To Adjust:

Place speed control lever on equipment in "RUN" (high speed) position.

Lever "C" on carburetor should be just touching choke arm at "D." To adjust, loosen casing clamp screw "A" on blower housing. Move control casing "B" forward or backward until correct position is obtained. Tighten screw "A."

Recheck operation of controls after adjustment. Replace air cleaner.

NOTE

If the engine cannot reach maximum governed speed, suspect a need for adjustment of the carburetor to provide the correct fuel/air mixture. Maximum speed is controlled by the engine governor which should only be serviced by an authorized servicing dealer. Carburetor adjustments and throttle linkage adjustments should never allow the engine to exceed the maximum governed speed.

ENGINE OIL

Read engine manual supplied with the mower.

ENGINE SPEED

The governed engine speed was set by the engine manufacturer. The governor overrides the throttle control and neither carburetor adjustments nor throttle settings can cause speeds higher than the governor controlled speeds. DO NOT ATTEMPT TO CHANGE THE GOVERNOR SPEED SETTING BY ADJUSTING THE LINKAGE. Clogging of the cooling passages (see "Cooling System") can cause harmful overspeeding of the engine. For engine service and parts see your nearest authorized engine servicing dealer.

COOLING SYSTEM

Lawn mowing is hard on the engine cooling system. Grass, chaff and dirt must be removed periodically from the cooling areas to avoid overspeeding and overheating which can harm the engine. For access to the area, the blower housing must be removed per instructions in the engine manual. If you do not wish to do it, your servicing dealer can do it for you.

AIR CLEANER

Clean the air cleaner every 25 hours under normal conditions and every few hours under extremely dusty conditions. Poor engine performance and flooding usually indicates need to service the air cleaner. Follow cleaning instructions in your engine manual.

CARBURETOR ADJUSTMENT

Minor carburetor adjustment may be required to compensate for differences in fuel, temperature, altitude and load. All carburetor adjustments must be made with the air cleaner in place on the carburetor. See engine manual supplied with the mower.

BATTERY CHARGING

⚠ WARNING

Use only the 12 volt battery charger supplied. Using any other charger could overheat the battery, possibly causing it to explode.

HANDLING INSTRUCTIONS

- Like all batteries, these units contain corrosive fluids and toxic materials and should be handled with care.
- As with all rechargeable batteries, explosive gases could be vented during charge or discharge. Charge battery in a well-ventilated area, away from source of ignition.
- Battery should be charged by adults only.
- Use only the battery charger specified.
- Do not make direct contact between positive and negative terminals as this could cause high current to flow, creating high heat and the possibility of a fire in the connecting part.

CAUTION

Use battery charger indoors only.

Battery may be charged while mounted on the mower.

1. Remove plastic shielding from battery harness to reveal the plug (J-terminal).
2. Disconnect battery harness from starter motor harness at plug.
3. Connect battery charger to battery harness. Make sure that battery harness terminals are clean and secure on battery.
4. Plug battery charger into 115 volt power supply.

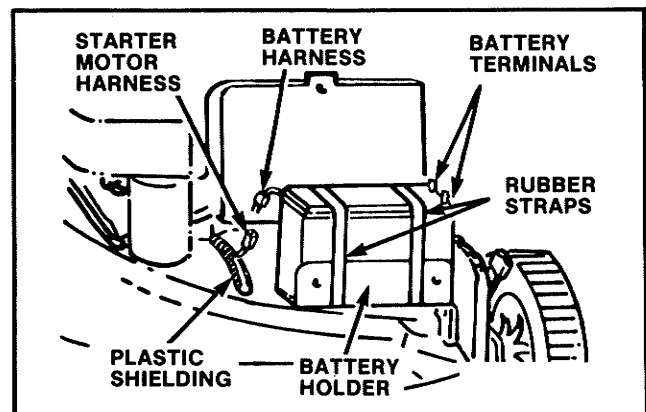

FIGURE 24

A fully discharged battery will be charged in 40 hours. Do Not charge battery for more than 40 hours — overcharging will reduce battery life.

- Do not leave charger connected to battery when charger is disconnected from the power supply.
- Always disconnect charger from power supply when not in use.

STORAGE

- Before off season storage, the battery should be fully charged and disconnected.
- Store battery on a wood shelf or pad in a cool, dry place.
- During off season storage, the battery should be fully charged every 30 days to prolong battery life.

FIRST AID

If the battery case cracks or breaks open as the result of severe abuse and some of the contents come in contact with skin or clothing, follow these instructions: **EXTER-**

NAL CONTACT — Immediately flush skin or eyes with water for at least 15 minutes. **INTERNAL** — Drink tap water, milk or milk of magnesia. Take whites of eggs. Do not give fluids that will induce vomiting. In case of internal or external contact, call a physician immediately.

CUTTING HEIGHT

All four wheels were set at the factory to a 1 1/2" (38 mm) cutting height. Until you have determined the right cutting height for your lawn, we recommend your setting the height at 2 1/2" (64 mm). The mower has height settings in 1/2" (13 mm) increments from 1 1/2 (38 mm) to 3 1/2" (90 mm). Put all four wheels in same position for even cutting. Do not place fingers under deck when making cutting height settings. Never adjust mower with the engine running.

LUBRICATION

WARNING

To avoid the possibility of serious bodily injury, when performing any lubrication, remove the spark plug wire from the spark plug.

WHEELS ON ALL MODELS

Lubricate wheels and the support shaft once a month or every 40 operating hours with SAE 30 oil. Tip mower on its side and apply oil to axle and hub. Spin wheel to allow oil to move into bearing. Oil the wheel support shafts at point where they enter deck. Move indexing levers or height adjusters back and forth to allow oil to move into bearing surfaces.

In extremely dusty conditions, wheels may become tight because of dust in bearing area. When this condition occurs, remove the wheels. Clean axle and wheel bearing surfaces with solvent or emery cloth, then oil and re-assemble. Torque to 190-285 in. lbs. (21 to 32 Nm).

REAR WHEELS ON POWER-PROPELLED MODELS

At the beginning of each season lubricate the wheels and pinions. Block up mower at rear of deck until the rear wheels are free.

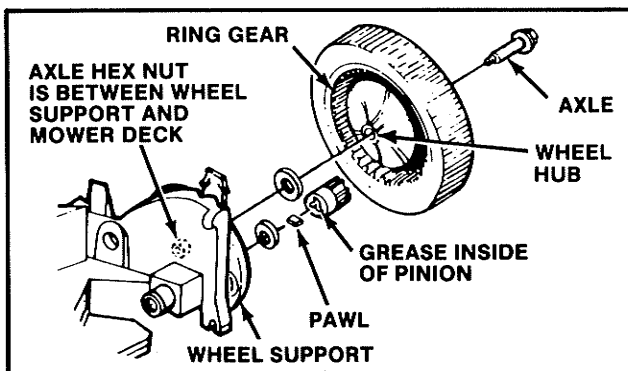

FIGURE 25

Remove the axle bolts and pull off the wheels. Apply a liberal amount of lithium base grease to pinion, ring gear, wheel hub, and axle (see Figure 25).

Be careful to install the pinions on the proper sides, as they are not interchangeable. Refer to Figure 26 for orientation of both the pawls and the pinions. Propulsion will occur only if parts are correctly installed.

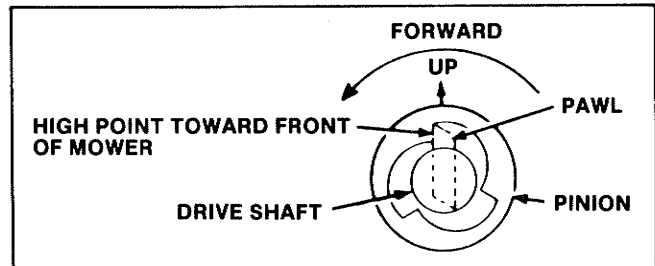

FIGURE 26

GEAR REDUCER OF POWER-PROPELLED MODELS

The gear reducer is filled with oil at the factory. Every 25 hours, or if leakage is apparent, remove the pipe plug. If oil level is below the hole, fill until oil is level with bottom of hole. Use Type "F" Automatic Transmission Fluid.

Do not substitute lubricant. If repair is necessary, see your authorized servicing dealer.

IMPORTANT

Use of improper lubricant will cause premature gear reducer failure.

STORAGE

AT THE END OF EACH SEASON

Always clean underside of the deck at the end of season, or if the mower is to be stored for any length of time. If necessary, a soft bristle scrub brush can be used to clean the wheels and tires, and a small stick can be used to clean out corners.

Make sure the fuel tank is empty, as gasoline can escape from the vent hole in the tank cap if the mower is tipped. Disconnect the spark plug wire. Be very careful if you touch the blade ends, as they are quite sharp. Tip the mower rearward and apply a stream of water directly at the underside of the deck until you have thoroughly cleaned it to your satisfaction.

Lubricate the mower as instructed under "Lubrication." Wipe the entire unit with a clean cloth to remove gasoline stains and oily spots.

The above simple procedures will keep your mower looking new for years to come.

ENGINE STORAGE

See engine manual.

FOLDING HANDLES

IMPORTANT

To avoid damage to cables do not fold the upper handle forward.

1. Press inward on both lower handle ends until they clear the handle stop on deck. Then push handle forward.
2. Loosen the two handle joining knobs.
3. Fold the upper handle rearward. Do not pinch the control cables.

⚠ WARNING

The engine controls will not function properly when the handles are removed from the mower or folded. To avoid accidental engine start-up and consequential injury, disable engine by disconnecting the spark plug wire. AND ALSO, disconnect battery from starter motor. To avoid injury, never grasp bottom edge of mower deck.

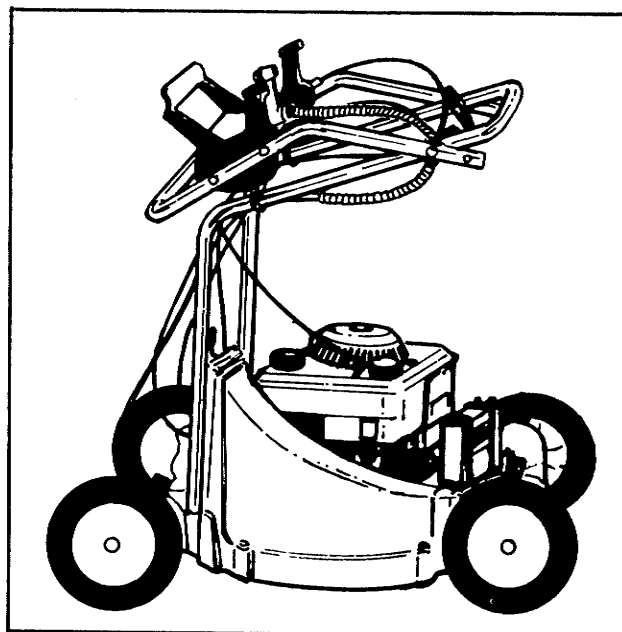

FIGURE 27

COMMON REPLACEMENT PARTS

Description	Model 1550es	Model 1550zs
	Part No.	
Blade	1612155	1612155
Blade Adaptor.....	1612331	1612331
Drive Belt	1612158	1612158
Front Wheels	1612423	1612423
Rear Wheels	1612398	1612398
Touch-Up Paint (13 oz. Spray Can)	103028	103028
Battery (12 volt)	1612159	1612159
Grass Bag	1612302	1612302

TROUBLESHOOTING

⚠ WARNING

To avoid the possibility of serious bodily injury, when performing any maintenance other than carburetor adjustment on engine, disconnect the spark plug wire from the spark plug. Battery should be disconnected.

PROBLEM	CAUSE	CORRECTION
DOES NOT START	<ol style="list-style-type: none"> 1. Out of fuel. 2. Spark plug wire disconnected from the spark plug. 3. Fouled spark plug. 4. Throttle control not in "RUN" or "CHOKE" position. 5. Stale fuel. 6. Moisture in fuel. 7. Engine flooded. 8. Grass too high. 	<ol style="list-style-type: none"> 1. Fill fuel tank. 2. Connect wire to spark plug. 3. Clean or replace spark plug-set gap to .030 of an inch. 4. Place throttle in proper position. See page 6. 5. Drain fuel tank and refill with fresh fuel. 6. Drain fuel tank and refill with fresh fuel. 7. Crank engine 4-5 times with throttle set to IDLE. 8. Move to low grass or no grass area.
LOSS OF POWER	<ol style="list-style-type: none"> 1. Dirty air cleaner. 2. Moisture or dirt in fuel 3. Carburetor misadjusted. 4. Build up of grass in the cutting deck. 5. Throttle not in proper operating position. 6. Cutting too much grass. 7. Throttle cable not adjusted. 	<ol style="list-style-type: none"> 1. Clean - follow instructions on page 12. 2. Drain fuel tank and refill with fresh fuel. 3. Adjust carburetor - instructions page 12. 4. Clean. 5. Adjust throttle. 6. Set height adjusters in higher position. See page 13. 7. Adjust - see engine manual.
EXCESSIVE VIBRATION	<ol style="list-style-type: none"> 1. Worn or bent blade. 2. Loose blade. 3. Incorrect sharpening. 4. Excessive grass build-up in deck. 	<ol style="list-style-type: none"> 1. Replace blade - see page 10. 2. Tighten blade bolt - see page 10. 3. Balance blade - see page 11. 4. Clean.
EXCESSIVE ENGINE SPEED	<ol style="list-style-type: none"> 1. Grass build-up around rotating screen and air cooling system. 	<ol style="list-style-type: none"> 1. See engine manual.
POOR QUALITY CUT	<ol style="list-style-type: none"> 1. Bent blade. 2. Worn blade. 3. Wheels set at different levels. 4. Engine running too slowly. 5. Build up of grass in the cutting deck. 	<ol style="list-style-type: none"> 1. Replace blade - see page 10. 2. Sharpen - see page 10. 3. Place all wheels at same height. 4. See "Loss of Power." 5. Clean the deck.
TRACTION DRIVE MALFUNCTION	<ol style="list-style-type: none"> 1. Broken or disconnected cable. 2. Slipping or slow engagement. 3. Belt out of pulley groove or broken. 4. Pinion or pawls reversed (no drive or free-wheeling). 	<ol style="list-style-type: none"> 1. Have serviced. 2. See page 11. 3. See belt installation, page 11. 4. See page 13.

Simplicity Manufacturing, Inc.
500 N. Spring Street
P.O. Box 997
Port Washington, WI 53074-0997

JA-99458-7
First Edition
1981