

Simplicity[®]

OPERATOR'S MANUAL

MODEL 1319

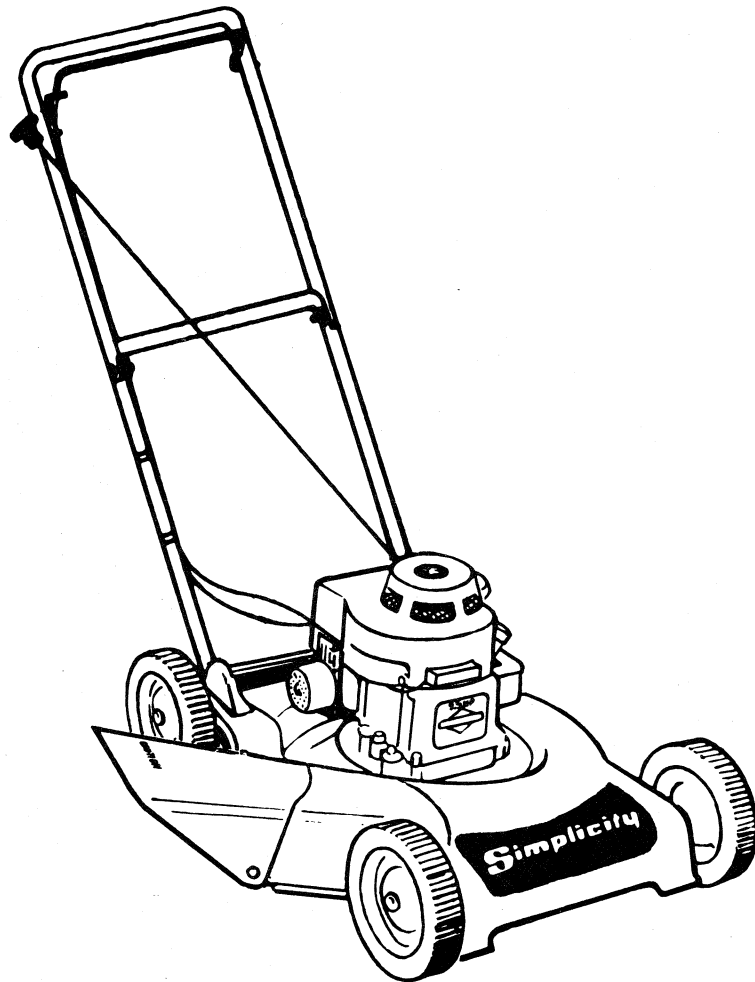

**1319 19" PUSH MOWER
MFG. NO. 1690796**



THIS MOWER MEETS CPSC BLADE SAFETY REQUIREMENTS

**CAUTION: Read Manual Thoroughly
Before Operating.**

**FORM 1671638
PRINTED IN U.S.A.
27-1694**



WARNING

Read these safety rules and follow them closely. Failure to obey these rules could result in loss of control of vehicle, severe personal injury to yourself or bystanders, or damage to property or equipment affecting safety.

Safety Rules



This notation preceding Cautions and Warnings in the text signifies important precautionary steps which, if not properly followed, could result in personal injury or damage to your equipment affecting safety.

SAFETY INSTRUCTIONS (ANS B71.1-1980)

TRAINING

1. Read the Operating and Service Instruction Manual carefully. Be thoroughly familiar with the controls and proper use of the equipment.
2. Never allow children to operate a power mower.
3. Keep the area of operation clear of all persons, particularly small children and pets.

PREPARATION

1. Thoroughly inspect the area where the equipment is to be used and remove all stones, sticks, wire, bones and other foreign objects.
2. Do not operate equipment barefoot or wearing open sandals. Always wear substantial footwear.
3. Check fuel before starting engine. Do not fill gasoline tank indoors, when engine is running, or while engine is still hot. Wipe off any spilled gasoline before starting engine.
4. Mow only in daylight or in good artificial light.
5. Never operate equipment in wet grass. Always be sure of your footing; keep a firm hold on the handle and walk, never run.

OPERATION

1. Do not change engine governor setting or overspeed engine.
2. Do not put hands or feet near or under rotating parts. Keep clear of discharge opening at all times.
3. Stop blade when crossing gravel drive, walks or roads.
4. After striking a foreign object, stop the engine, remove wire from spark plug, thoroughly inspect the mower for any damage, and repair the damage before restarting and operating the mower.

5. If the equipment should start to vibrate abnormally, stop the engine and check immediately for the cause. Vibration is generally a warning of trouble.
6. Stop engine whenever you leave the equipment, before cleaning mower housing, and when making any repairs or inspections.
7. When cleaning, repairing or inspecting, make certain blade and all moving parts have stopped. Disconnect spark plug wire and keep wire away from plug to prevent accidental starting.
8. Do not run engine indoors.
9. Shut engine off and wait until blade comes to a complete stop before removing grass catcher and/or unclogging chute.
10. Mow across the face of slopes, never up and down. Exercise extreme caution when changing direction on slopes. Do not mow excessively steep slopes.
11. NEVER operate mower without proper guards, plates or other safety protective devices in place.
12. Never attempt to defeat government required blade safety stop device.

MAINTENANCE AND STORAGE

1. Check blade and engine mounting bolts at frequent intervals for proper tightness.
2. Keep all nuts, bolts, and screws tight to be sure equipment is in safe working condition.
3. Never store equipment with gasoline in the tank inside of a building where fumes may reach an open flame or spark. Allow engine to cool before storing in any enclosure.
4. To reduce fire hazard keep engine free of grass, leaves or excessive grease.
5. Check grass catcher bag frequently for wear or deterioration. Replace with new bag for safety protection.
6. Check blade stop device. Repair if stopping time exceeds three (3) seconds.

OPERATE THIS MOWER SAFELY
 ...By thinking before acting
 ...By reading this manual
 ...By heeding labels on the machine



CAUTION
BLADE TURNS WITH ENGINE
ON THIS MOWER.

ASSEMBLY INSTRUCTIONS

SETTING UP THE HANDLE

The handle is attached to the mower. To set up ready for use, pull the handle upward and back toward you, making sure that you do not kink the cables in the process. The lower handle will snap into position in the brackets when the entire handle is extended upward and to the rear. Tighten the two wing nuts securely. It may be necessary to squeeze the bail control on the upper handle to allow the engine starter rope to be pulled out of the engine as the handle nears its final position.

Check upper end of the engine control cable to see that the end fitting is resting in the first bend of the bail handle (See Figure 1). If it is not in the proper position the blade brake will not release and the starter rope will be difficult or impossible to pull when the bail is operated.

Near the engine there is a knot in the starter rope. Pull the pin out of the knot and the knot will release itself. The rope will then be taut between the engine and the eyebolt on the handle.



CAUTION
BLADE WILL TURN AS YOU RAISE THE
HANDLE WITH THE BAIL HELD IN THE
DOWN POSITION.

FOLDING THE HANDLE FOR STORAGE

The handle may be folded down over the engine for storage. First loosen the two wing nuts and fold the upper handle down to the rear, guiding the rope and cables away from the folding joint. Then squeeze the legs of the lower handle until the whole assembly can be swung forward over the engine.

To ready for use, grasp handle and operate the bail engine control. Pull handle upward and to the rear toward you until handle snaps into position. Tighten wing nuts. **BLADE WILL TURN AS YOU RAISE THE HANDLE WITH THE BAIL CONTROL OPERATED. KEEP FEET AWAY FROM BLADE!**

The handle can also be stored in the straight up position, thereby saving storage space. Squeeze the legs of the lower handle until the handle assembly can be raised to the straight up position. To use, pull handle down to the operating position, squeezing the bail.

CHUTE EXTENSION INSTALLATION (See Figure 2)

The chute extension must be installed before using mower. Insert carriage bolts from inside chute as shown and tighten nuts **SECURELY**.

CUTTING HEIGHT ADJUSTMENT



CAUTION
DO NOT PUT HANDS OR FINGERS UNDER
HOUSING TO CHANGE CUTTING HEIGHTS.
DO NOT CHANGE CUTTING HEIGHT WHILE
ENGINE IS RUNNING.

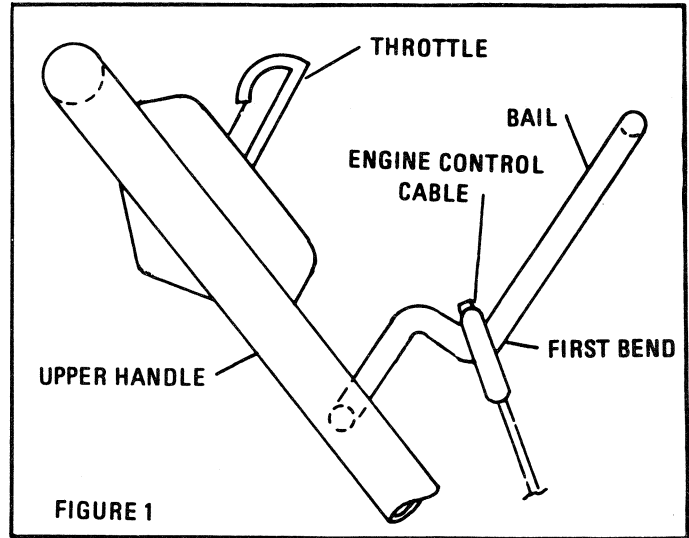

FIGURE 1

Wheels are bolted to the housing with shoulder bolts. To change cutting heights the wheel bolts must be removed and moved up or down to the desired hole. The correct order of reassembly of the wheel and bolt and washer is as follows: Put the wheel on the bolt, put flat washer (one or more) on to threaded portion of bolt, put threaded portion of bolt into desired hole so that washer is against the housing. Put nut on bolt and tighten securely.

Cutting heights are 1-1/4", 2", 2-3/4".

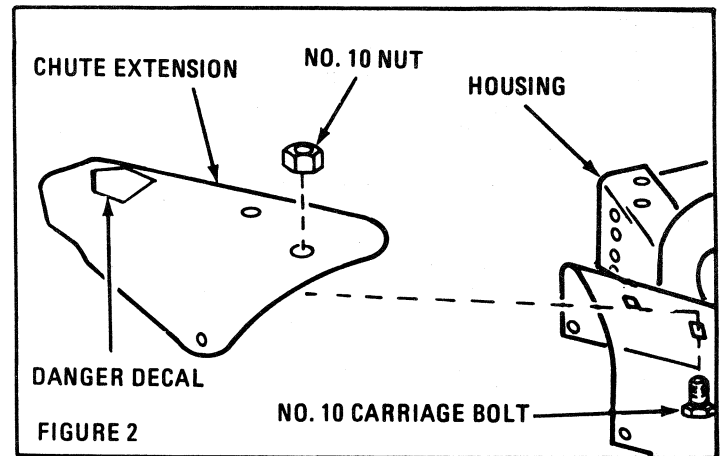

FIGURE 2

BEFORE STARTING THE ENGINE

1. Put a good quality detergent oil in the crankcase to the full mark on dip stick – **DO NOT FILL TO OVERFLOW!**

RECOMMENDED OIL
 above 40°F (Summer SAE 30)
 below 40°F (Winter SAE 5W-20)

2. Fill gas tank with clean, fresh regular gasoline.

STARTING THE ENGINE

It is recommended to start mower on level ground, preferably a paved walk or driveway, not gravel.

1. Move throttle control to the "Fast" position (engine is equipped with automatic choke).

2. While standing in the operating position, squeeze the bail control with the left hand and grasp the handle of the starter rope with the right hand.
3. Pull starter rope sharply.
4. As soon as the engine starts, move the throttle control to the desired speed.



CAUTION
DO NOT PULL STARTER CORD WHILE
ENGINE IS RUNNING.

5. To stop engine, release the bail.

MAINTENANCE

GENERAL

1. Change oil every cutting season or every 25 hours of operation. Refer to Engine Instruction Manual for complete instructions on lubrication, operation and care of the engine.
2. At the end of the cutting season, run gas tank dry, remove spark plug and put several squirts of motor oil in cylinder. Replace plug.
3. Keep all bolts tight. Inspect several times during cutting season.
4. Put several drops of oil on the wheel bearings occasionally.
5. Keep blade sharp (see section on blade sharpening).
6. Check blade stopping time occasionally when the bail is released. Blade should stop within three seconds of release. If blade does not stop within this time take mower to your service station for repair. Quick stopping time is for your protection.

TROUBLESHOOTING

1. Starter rope is very difficult or impossible to pull.
 - a. Check rope for binding at the eyebolt on handle.
 - b. Check control cable from bail down to engine. If cable is not moving where it enters the engine when the bail is operated, check for breakage or misplacement of the upper end of cable. Eye on end of cable should be nested in the first bend in the bail (See figure 2).
2. Starter rope turns engine over but engine won't start.
 - a. Check for gasoline in tank.
 - b. Check spark plug wire for contact with spark plug
 - c. Check spark to plug. Remove spark plug wire from plug and place 1/16" from end of plug. Pull starter sharply. A spark jumping the gap should be visible. If no spark occurs, magneto system is probably faulty. Perform this check in the shade as spark may not be visible in bright sun. Take mower to closest authorized engine service station for repair.

To locate nearest authorized engine service station, check yellow pages under listing, "Engines, Gasoline", and look for the make of the engine (Briggs & Stratton).

REMOVING BLADE (See Figure 3)



CAUTION
BEFORE WORKING ON BLADE DIS-
CONNECT SPARK PLUG WIRE!

Most new blades are razor sharp and should be handled with extreme care. Used blades may have sharp edges and burrs also. To protect against cuts, wrap end of blade in cloth. A long 9/16" offset box end wrench is the safest and easiest to use for removing the blade bolt. Hold the padded blade with one hand while loosening the bolt with the wrench. When the bolt is removed entirely the blade will come loose.

After sharpening or when replacing with a new blade, first inspect the blade adapter for cracks. If the adapter has been removed, be sure the woodruff key is in the engine slot and does not slip out as the adapter is slid onto the engine shaft. Replace blade with rectangular washer and lock washer as shown and tighten engine bolt securely. Recommended torque is 35 ft.-lbs.

**AN UNBALANCED OR BENT BLADE WILL CAUSE VIBRATION
DAMAGE NOT COVERED BY WARRANTY.**

Keeping a spare sharp blade on hand will avoid delay when replacement becomes necessary (See parts list for ordering instructions).

SHARPENING BLADE (See "Removing Blade")

Always disconnect spark plug wire before working on the mower! After removal the blade may be sharpened with a file or grinding wheel. Make sure blade is in balance before use. Balance of blade may be determined by balancing blade on sharp edge or hanging on string or wire through the center hole.

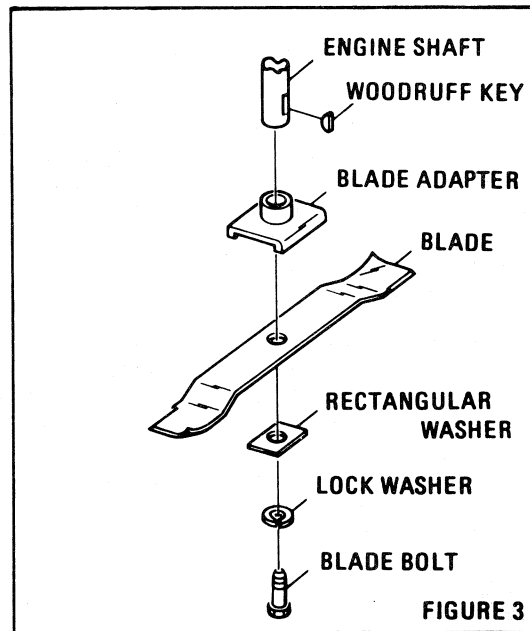

FIGURE 3

PROTECTIVE FEATURES

This mower has certain features designed to comply with current standards (ANSI B71.1-1980) and U.S. Government (Consumer Product Safety Commission—CPSC) standard Part No. 1205. These standards are for added protection for the user and include:

1. Blade and engine stopping device (CPSC)
2. Chute extension
3. Trailing plate

**THE MOWER SHOULD NEVER BE OPERATED WITHOUT THESE
FEATURES IN PLACE AND FUNCTIONING PROPERLY!**

BLADE STOPPING DEVICE

This device is required by U.S. Government law. The device stops the engine and the blade within three seconds after release of the bail control on the handle. **NEVERTHELESS**, make sure engine and blade have stopped and that the spark plug wire is disconnected before working around the engine or blade area.

CHUTE EXTENSION

The chute extension should always be kept in place. The purpose of this chute extension is to keep thrown objects close to the ground where they can do a minimum of damage.

TRAILING PLATE

The trailing plate helps prevent accidental contact with the blade from the rear and to reduce the danger from objects thrown toward the rear of the mower by the blade.

GRASS CATCHER

The grass catcher is an optional item and is highly recommended for keeping lawns free from clippings (Part No. 1690363).

If grass catcher is used with mower, install using the two carriage bolts on top of the chute. **DO NOT REMOVE CHUTE EXTENSION!** Catcher is designed to be used with chute extension in place.

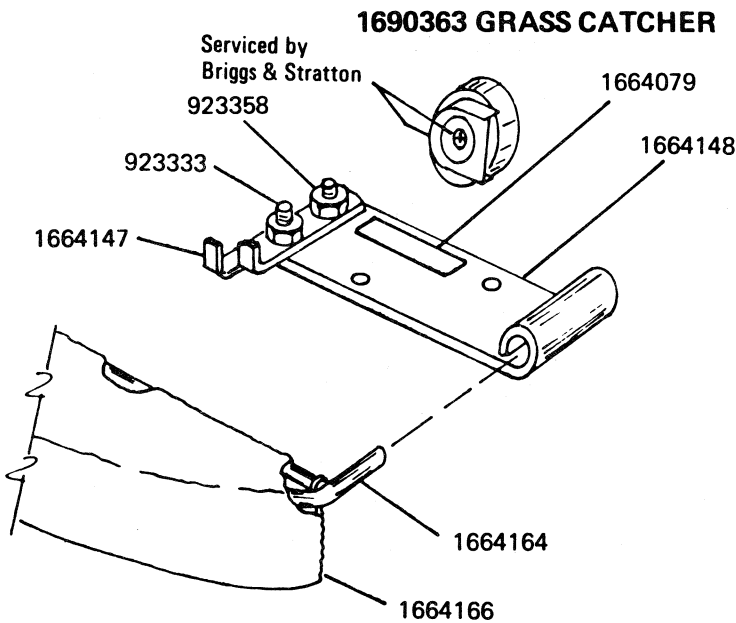

UNDER NORMAL USAGE THIS BAG IS SUBJECT TO WEAR AND DETERIORATION AND SHOULD BE CHECKED PERIODICALLY. BE SURE ANY REPLACEMENT BAG MEETS MANUFACTURER'S SPECIFICATIONS.

MAJOR CAUSES OF INJURY

The major causes of injury with a lawn mower are as follows:

1. Placing of hands or feet under the mower while the engine is running. Hands and feet may come into contact with the blade in several ways. If the grass chute should become clogged for any reason, the operator should not reach into the chute to remove the grass with the engine running and thereby come into contact with the blade.

When pulling the mower backward up a steep hill, the feet may slip under the mower and come into contact with the blade. When mowing on a steep slope, always mow along the slope, never up and down. Wear substantial footwear that discourages slipping.

Objects may be thrown toward the rear of the mower by the blade. The trail guard will help prevent thrown objects from ejecting from the rear of the mower, as well as help protect the feet from coming in contact with the blade from the rear.



NEVER WIRE UP OR REMOVE THE TRAILING GUARD!

2. The mower blade may pick up an object and throw it with high velocity out of the grass chute opening. The chute extension will tend to hold down thrown objects in a low trajectory where they can do the least harm.

Always clean up the yard before mowing, particularly in the spring before the first mowing. Remove all stones and other objects that might be thrown by the mower. Do not allow children or pets in the vicinity when mowing.



ALWAYS HAVE THE CHUTE EXTENSION IN PLACE!

3. The operator should never attempt to lift the mower with the engine running, thereby possibly getting his fingers in the path of the blade. Exercise care in lifting mower when engine is stopped. Blade is extremely sharp. Edges of housing may also be sharp.



NEVER LIFT MOWER WHILE ENGINE IS RUNNING!

Blade brake is subject to wear, possible malfunction, and should be checked periodically for required three (3) second stopping time.



NEVER ATTEMPT TO DEFEAT GOVERNMENT REQUIRED BLADE SAFETY STOP DEVICE.

The following decal and its location is noted below to alert you of possible danger. **ALWAYS OBSERVE SAFETY DECALS!**

Caution
Do Not Operate Mower Unless All Safety Guards Or Grasscatcher Are In Their Proper Place.



Chute Area

THINK SAFETY, ACT SAFELY!

PARTS LIST FOR MODEL 1690796

Ref. No.	Part No.	Description	Qty.	Ref. No.	Part No.	Description	Qty.
1	1671620	Bail – Control	1	28	930651	Nut – Baffle	4
2	922837	Bolt – Throttle 1/4-20 x 1-1/2	1	29	927187	Screw – Engine	3
3	1671655	Control Cable	1	30	910224	Key – Engine Shaft	1
4	1671623	Eyebolt	1	31	1664060	Blade Adapter Assembly	1
5	1663834	Decal – Deck, Simplicity	1	32	1664040	Blade	1
6	1671624	Nut – 1/4-20 Hex	1	33	1664074	Spacer – Blade Adapter	1
7	923358	Nut – Hex 1/4-20 Locking	2	34	916965	Washer – Blade	1
8	1671621	Control – Throttle	1	35	927008	Bolt – Blade	1
9	1671652	Bracket – Cable Mounting	1	36	924280	Pop Rivet	2
10	1671619	Handle – Upper	1	37	1671991	Clip – Trailguard	2
11	1671630	Bolt – Handle	2	38	1671649	Decal – Danger & Caution	1
12	108812	Clamp – Cable	2	39	1664070	Washer – Curved	2
13	1664053	Bracket Assembly – Yoke, R.H.	1	40	923300	Washer – Lock	2
14	1664184	Rivet – 1/4" Pop	3	41	918468	Nut – Wing	2
15	1664052	Bracket Assembly – Yoke, L.H.	1	42	1664062	Clamp – Casing	1
16	1671625	Trailguard	1	43	1671629	Screw – Hex Head	1
17	1664083	Chute Extension	1	44	1664068	Screw – Casing	2
18	1664065	Bolt – Carriage	3	45	1669639	Yoke	1
19	1664067	Nut – Keps	3	46	170489	Decal – 19"	1
20	1664044	Housing	1	47	106719	Decal – Simplicity 6"	1
21	1671631	Bolt – 1/4-20 x 1/2	4	48	1671647	Decal – Engine Control	1
22	1664071	Baffle	2	49	1671648	Decal – Starting Instructions	1
23	1668749	Bolt – Shoulder	4				
24	917642	Washer – 3/8 Flat	4				
25	1671627	Wheel Assembly w/Bearing 7"	4				
26	1664058	Bearing – Wheel	4				
27	1664176	Guard – Blade	1				
						OPTIONAL ACCESSORY	
					1690363	Grass Catcher	
					1664166	Replacement Bag	

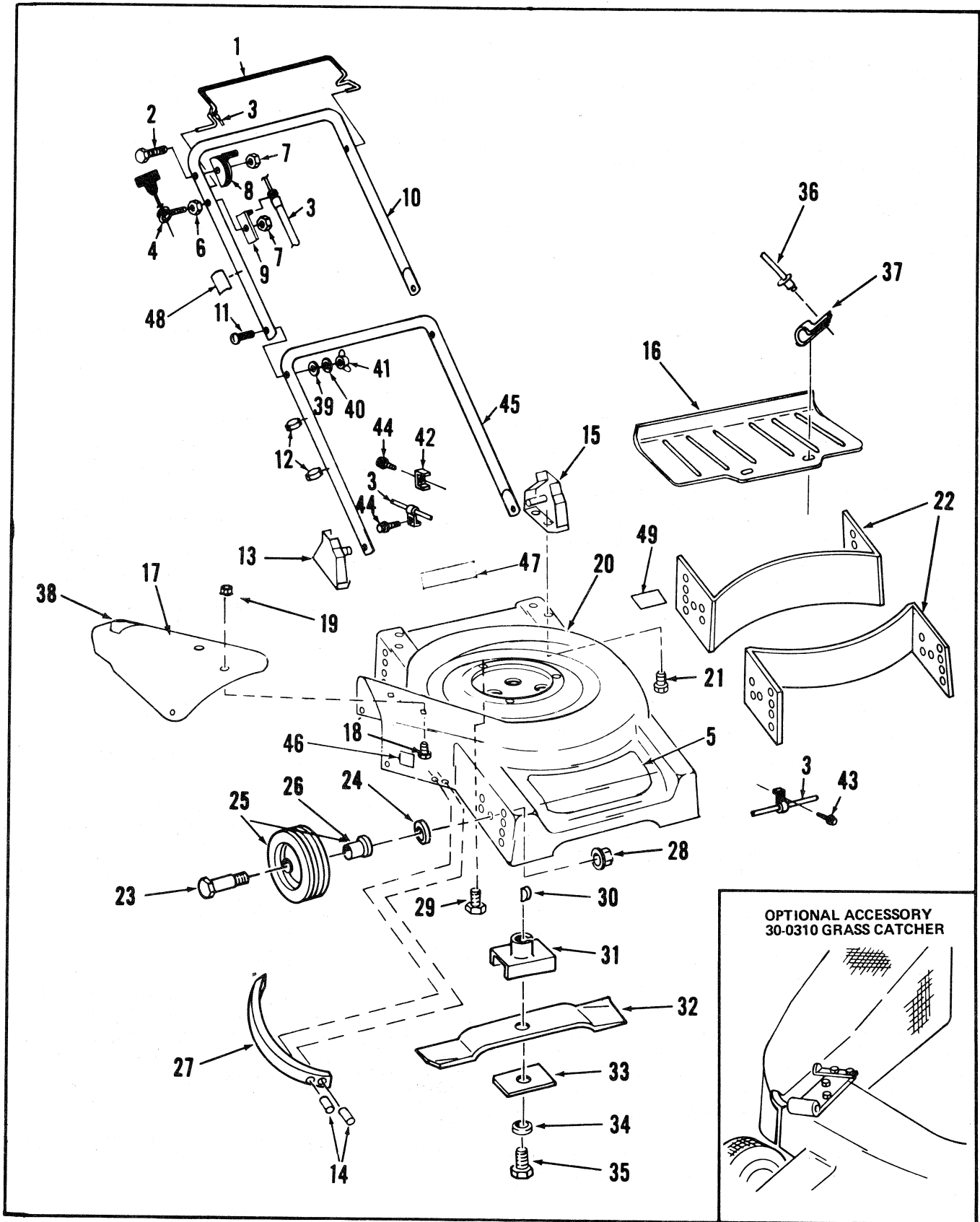

INSTRUCTIONS FOR ORDERING PARTS... MOWER PARTS can be ordered from the dealer from whom your mower was purchased or from an authorized parts distributor. Be sure to specify the part number, not reference number, and the description of each required item - also, the model and serial number of your mower.

LIMITED WARRANTY

COVERED BY WARRANTY

Simplicity Manufacturing Company, Division of Allis Chalmers Corporation (The Company), warrants to the owner that each new product listed below is merchantable and free of defects in workmanship and material.

During the warranty period, any authorized Company Dealer will provide, free of charge, both parts and labor necessary to correct any defect in workmanship and material.

WARRANTY PERIOD

The Simplicity Products listed below are warranted for the stated period from the date of the original purchase:

- | | |
|---|-----------|
| (1) All lawn, garden, snow, and other equipment | 12 Months |
| (2) Repair parts | 90 Days |

Repair parts installed on products receive the same warranty period remaining for the product or 90 days, whichever is longer.

OWNER RESPONSIBILITIES

The owner of a new Simplicity Product must do the following to qualify for warranty service:

(1) Retain the original invoice or other proof of purchase or send in your warranty registration card to avoid unnecessary difficulties in determining your eligibility for warranty work. (Warranty registration card not required to obtain warranty work if other proof of purchase is shown.)

(2) Notify your nearest Simplicity dealer as soon as possible after discovery of a possible defect, and provide proof of original purchase or warranty registration card (if any). If you are not aware of your nearest Simplicity dealer write for such information to: Simplicity Manufacturing Company, Division of Allis Chalmers Corporation, Attn: Customer Services, 500 N. Spring Street, Port Washington, WI 53074.

(3) Return your equipment, or parts, to your nearest authorized Simplicity Dealer for inspection and warranty service.

NOT COVERED BY WARRANTY

The following are not covered by this warranty:

- (1) Transportation charges to and from dealers; OR
- (2) New products which have been subject to operation in excess of recommended capacities, misuse, negligence or accident, or have been altered or repaired in a manner not authorized by Company; OR
- (3) Engine, tires, generators, voltage regulators, transaxles, or accessories that are warranted separately by their respective manufacturers, except Company agrees to make available to the owners whatever warranty benefits may be made available to the Company by the manufacturers.

ALL IMPLIED WARRANTIES, EXCEPT TO THE EXTENT PROHIBITED BY ANY APPLICABLE LAW, SHALL HAVE NO GREATER DURATION THAN THE WARRANTY PERIOD FOR THE APPLICABLE PRODUCT. SOME STATES DO NOT ALLOW LIMITATIONS ON HOW LONG AN IMPLIED WARRANTY LASTS, SO THE ABOVE LIMITATION MAY NOT APPLY TO YOU.

THE COMPANY'S LIABILITY ARISING OUT OF WARRANTIES, REPRESENTATIONS, INSTRUCTIONS, OR DEFECTS FROM ANY CAUSE, SHALL BE LIMITED EXCLUSIVELY TO REPAIR OR REPLACING PARTS UNDER THE CONDITIONS IN THIS WARRANTY, AND IN NO EVENT WILL COMPANY BE LIABLE FOR INCIDENTAL OR CONSEQUENTIAL DAMAGES. SOME STATES DO NOT ALLOW THE EXCLUSION OR LIMITATION OR INCIDENTAL OR CONSEQUENTIAL DAMAGES, SO THE ABOVE LIMITATION OR EXCLUSION MAY NOT APPLY TO YOU.

THIS WARRANTY GIVES YOU SPECIFIC LEGAL RIGHTS, AND YOU MAY ALSO HAVE OTHER RIGHTS WHICH VARY FROM STATE TO STATE.

SIMPLICITY MANUFACTURING COMPANY
500 North Spring Street Port Washington, Wisconsin 53074