



OPERATOR'S MANUAL



Coronet Series

11HP Gear Riders

Mfg. No.	Description
1693030	Coronet, 11HP Gear
1693032	Coronet, 11HP Gear (Export)

13HP Hydro Riders

Mfg. No.	Description
1693034	Coronet, 13HP Hydro
1693036	Coronet, 13HP Hydro (Export)

14HP Hydro Riders

Mfg. No.	Description
1693038	Coronet, 14HP Hydro
1693040	Coronet, 14HP Hydro (Export)

30" Mower Decks

Mfg. No.	Description
1692543	30" Mower Deck

34" Mower Decks

Mfg. No.	Description
1692545	34" Mower Deck
1693168	34" Mower Deck (Export)



MANUFACTURING, INC.
500 N Spring Street / PO Box 997
Port Washington, WI 53074-0997

www.simplicitymfg.com

© Copyright 1997 Simplicity Manufacturing, Inc.
All Rights Reserved. Printed in USA.

AGCO ALLIS

OPERATOR'S MANUAL



400 Series

Riders

Mfg. No.	Description
1693042	411G, 11HP Gear
1693044	412H, 13HP Hydro
1693046	414H, 14HP Hydro

Mower Decks

Mfg. No.	Description
1692544	30" Mower Deck
1692546	34" Mower Deck



AGCO ALLIS

AGCO-Allis Lawn & Garden Equipment
500 N. Spring Street \ P.O. Box 997
Port Washington, WI 53074-0997 USA

www.allislawn.com

© Copyright 1997 Simplicity Manufacturing, Inc.
All Rights Reserved. Printed in USA.

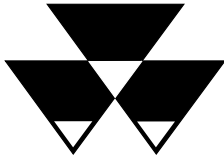

MASSEY FERGUSON
LAWN & GARDEN EQUIPMENT

OPERATOR'S MANUAL



2400 Series

Riders

Mfg. No.	Description
1693048	2411G, 11HP Gear
1693050	2414H, 13HP Hydro

Mower Decks

Mfg. No.	Description
1692544	30" Mower Deck
1692546	34" Mower Deck



MASSEY FERGUSON
LAWN & GARDEN EQUIPMENT

Massey Ferguson Lawn & Garden Equipment
is Manufactured and Distributed by Simplicity Manufacturing, Inc.
500 N. Spring Street • P.O. Box 997 • Port Washington, WI 53074-0997 USA

www.masseylawn.com

© Copyright 1997 Simplicity Manufacturing, Inc.
All Rights Reserved. Printed in USA.

Table Of Contents

RIDER & MOWER IDENTIFICATION	2	TROUBLESHOOTING & REPAIR	21
SAFETY RULES	3	General.....	21
SAFETY DECALS	5	Troubleshooting The Rider.....	21
FEATURES & CONTROLS	6	Troubleshooting The Mower.....	22
Rider Features & Controls.....	6	Checking the Battery.....	22
Engine Compartment.....	7	Charging A Completely Discharged Battery.....	22
Safety Interlock System.....	8	Jump Starting with Auxiliary (Booster) Battery.....	23
OPERATION	9	ADJUSTMENTS	25
General.....	9	Seat Adjustment.....	25
Mower Removal & Installation.....	9	Brake Adjustment.....	25
Operating The Mower.....	10	Steering Gear Adjustment.....	26
Checks Before Starting.....	10	Steering Wheel Adjustment.....	26
Clutch/Brake Pedal Operation.....	11	Mower Adjustments.....	26
Starting The Engine.....	11	BELT REPLACEMENT	29
Selecting Ground Speed & Engine Speed.....	11	Rider Drive Belt.....	29
Stopping the Rider.....	12	Mower Belt - 30".....	29
Neutral Safety Checks.....	12	Mower Belt - 34".....	29
Pushing the Rider by Hand.....	12	SPECIFICATIONS	30
MOWING PATTERN & TIPS	13	INTERNATIONAL SYMBOLS	31
NORMAL CARE	15	PARTS & ACCESSORIES	32
Schedule.....	15	Common Replacement Parts.....	32
Raising the Seat Deck.....	15	Maintenance Items.....	32
Checking/Adding Gasoline.....	15	Optional Accessories.....	32
Checking Tire Pressure.....	15	TECHNICAL MANUALS	32
Checking the Fuel Filter.....	15		
Lubrication.....	16		
Battery Maintenance.....	17		
Checking the Battery Fluid.....	17		
Cleaning the Battery and Cables.....	17		
Servicing the Mower Blades.....	17		
STORAGE	19		
Temporary Storage.....	19		
Long Term Storage.....	19		
Starting After Long Term Storage.....	20		

NOTE: In this manual, "left" and "right" are referred to as seen from the operating position.

WARNING

Engine exhaust from this product contains chemicals known, in certain quantities, to cause cancer, birth defects, or other reproductive harm.

Rider & Mower Identification

IDENTIFICATION NUMBERS

Record your model number, manufacturer number and engine identification number in the space provided for easy reference. The models and manufacturer numbers covered in this manual are listed on the front cover. The rider I.D. tag is located on the left-side of the frame, in front of the rear tire, as shown below. The mower deck I.D. tag is also on the left side, on top of the mower deck.

Refer to the engine Owner's Manual for location of engine identification number.

Be sure to fill out and return the Warranty Registration Card supplied with your rider.

MODEL REFERENCE
Model Number: _____
Manufacturer Number: _____
Engine I.D. Number: _____
Dealer Name/Date Purchased: _____

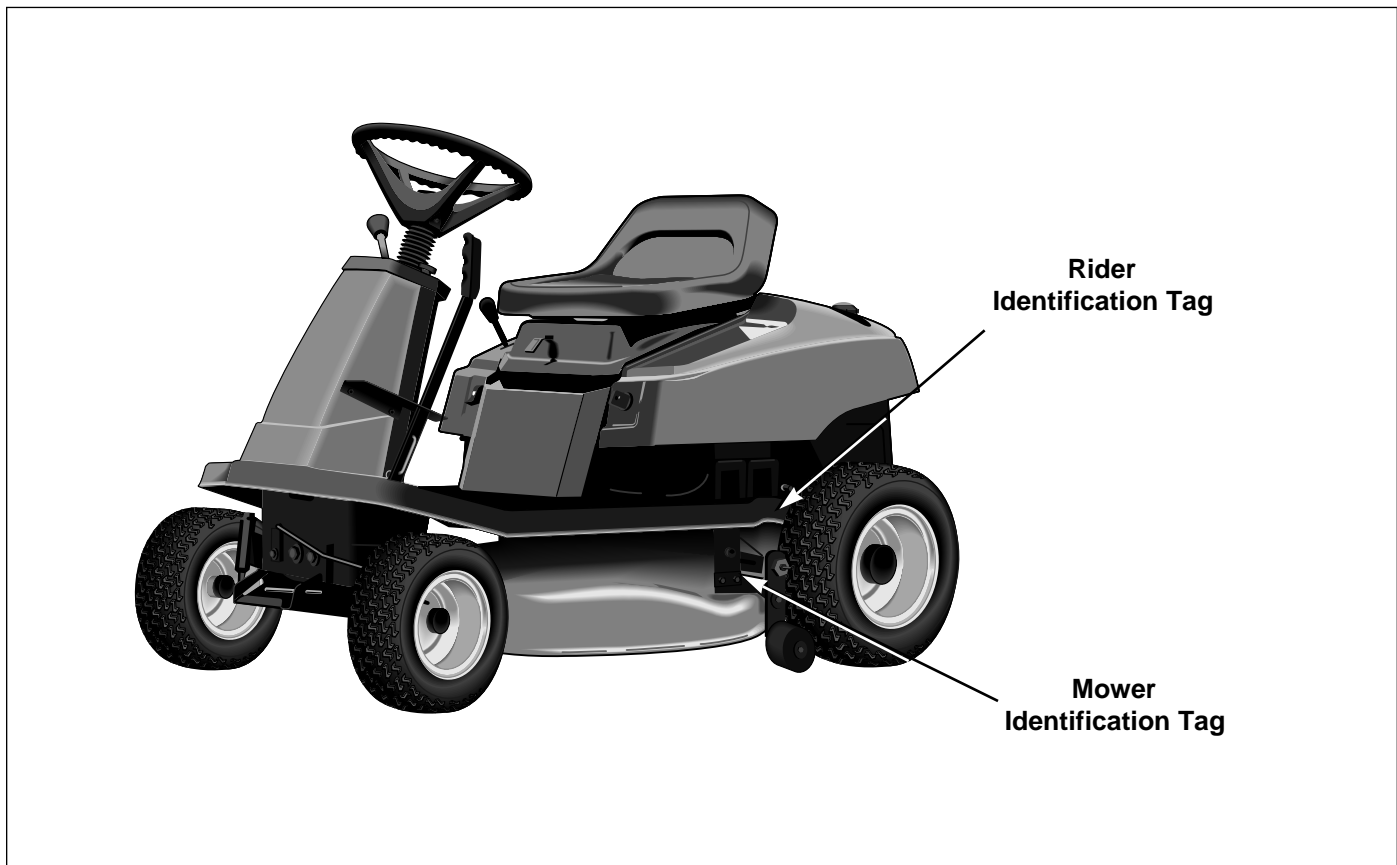



Figure 1. Rider & Mower Identification Tags



Read these safety rules and follow them closely. Failure to obey these rules could result in loss of control of rider, severe personal injury or death to you, or bystanders, or damage to property or equipment. **This mowing deck is capable of amputating hands and feet and throwing objects.** The triangle  in text signifies important cautions or warnings which must be followed.

GENERAL OPERATION

- Read, understand, and follow all instructions in the manual and on the unit before starting.
- Only allow responsible adults, who are familiar with the instructions, to operate the unit.
- Clear the area of objects such as rocks, toys, wire, etc., which could be picked up and thrown by the blade(s).
- Be sure the area is clear of other people before mowing. Stop unit if anyone enters the area.
- Never carry passengers.
- Do not mow in reverse unless absolutely necessary. Always look down and behind before and while travelling in reverse.
- Be aware of the mower discharge direction and do not point it at anyone. Do not operate the mower without either the entire grass catcher or the deflector in place.
- Slow down before turning.
- Never leave a running unit unattended. Always disengage the PTO, set parking brake, stop engine, and remove keys before dismounting.
- Turn off the PTO switch to disengage the blades when not mowing.
- Stop engine before removing grass catcher or unclogging chute.
- Mow only in daylight or good artificial light.
- Do not operate the unit while under the influence of alcohol or drugs.
- Watch for traffic when operating near or crossing roadways.
- Use extra care when loading or unloading the unit into a trailer or truck.

SLOPE OPERATION

Slopes are a major factor related to loss-of-control and tip-over accidents, which can result in severe injury or death. All slopes require extra caution. If you cannot back up the slope or if you feel uneasy on it, do not mow it.

WARNING - SLOPE OPERATION

Never operate on slopes greater than 30 percent (16.7°) which is a rise of three feet vertically in 10 feet horizontally. When operating on slopes that are greater than 15 percent (8.5°) but less than 30 percent use front counterweights and rear wheel weights (see your dealer). Select slow ground speed before driving onto slope. In addition to front and rear weights, use extra caution when operating on slopes with rear-mounted grass catcher. Mow UP and DOWN the slope, never across the face, use caution when changing directions and DO NOT START OR STOP ON SLOPE.

Do

- See your authorized dealer for recommendations of wheel weights or counterweights to improve stability.
- Mow up and down slopes, not across.
- Remove obstacles such as rocks, tree limbs, etc.
- Watch for holes, ruts, or bumps. Uneven terrain could overturn the unit. Tall grass can hide obstacles.
- Use slow speed. Choose a low gear so that you will not have to stop or shift while on the slope.
- Use extra care with grass catchers or other attachments. These can change the stability of the unit.
- Keep all movement on the slopes slow and gradual. Do not make sudden changes in speed or direction.

Do Not

- *Do not* start or stop on a slope. If tires lose traction, disengage the blade(s) and proceed slowly straight down the slope.
- *Do not* turn on slopes unless necessary, and then, turn slowly and gradually downhill, if possible.
- *Do not* mow near drop-offs, ditches, or embankments. The mower could suddenly turn over if a wheel is over the edge of a cliff or ditch, or if an edge caves in.
- *Do not* mow on wet grass. Reduced traction could cause sliding.
- *Do not* try to stabilize the unit by putting your foot on the ground.
- *Do not* use grass catcher on steep slopes.

Safety Rules

CHILDREN

Tragic accidents can occur if the operator is not alert to the presence of children. Children are often attracted to the unit and the mowing activity. Never assume that children will remain where you last saw them.

- Keep children out of the mowing area and under the watchful care of another responsible adult.
- Be alert and turn unit off if children enter the area.
- Before and when backing, look behind and down for small children.
- Never carry children. They may fall off and be seriously injured or interfere with safe unit operation.
- Never allow children to operate the unit.
- Use extra care when approaching blind corners, shrubs, trees, or other objects that may obscure vision.

TRANSPORTING AND STORAGE

- Always observe safe refueling and fuel handling practices when refueling the rider after transportation or storage.
- Always follow the engine manual instructions for storage preparations before storing the rider for both short and long term periods.
- Always follow the engine manual instructions for proper start-up procedures when returning the unit to service.
- Never store the unit or fuel container inside where there is an open flame or pilot light, such as in a water heater. Allow unit to cool before storing.

SERVICE AND MAINTENANCE

- Use extra care in handling gasoline and other fuels. They are flammable and vapors are explosive.
 - a) Use only an approved container.
 - b) Never remove gas cap or add fuel with the engine

running. Allow engine to cool before refueling. Do not smoke.

- c) Never refuel the unit indoors.
 - Never run a unit inside a closed area.
- Keep nuts and bolts, especially blade attachment bolts, tight and keep equipment in good condition.
- Never tamper with safety devices. Check their proper operation regularly.
- Keep unit free of grass, leaves, or other debris build-up. Clean up oil or fuel spillage.
- Stop and inspect the equipment if you strike an object. Repair, if necessary, before restarting.
- Never make adjustments or repairs with the engine running unless specified otherwise in the engine manufacturer's manual.
- Grass catcher components are subject to wear, damage, and deterioration, which could expose moving parts or allow objects to be thrown. Frequently check components and replace with manufacturer's recommended parts, when necessary.
- Mower blades are sharp and can cut. Wrap the blade(s) or wear gloves, and use extra caution when servicing them.
- Check brake operation frequently. Adjust and service as required.
- Use only factory authorized replacement parts when making repairs.
- Always comply with factory specifications on all settings and adjustments.
- Only authorized service locations should be utilized for major service and repair requirements.
- Never attempt to make major repairs on this unit unless you have been properly trained. Improper service procedures can result in hazardous operation, equipment damage and voiding of manufacturer's warranty.

This unit has been designed and manufactured to provide you with the safety and reliability you would expect from an industry leader in outdoor power equipment manufacturing.

Although reading this manual and the safety instructions it contains will provide you with the necessary basic knowledge to operate this equipment safely and effectively, we have placed several safety labels on the unit to remind you of this important information while you are operating your rider.

All WARNING, CAUTION and instructional messages on

your rider and mower should be carefully read and obeyed. Personal bodily injury can result when these instructions are not followed. The information is for your safety and it is important! The safety decals shown below are on your rider and mower.

If any of these decals are lost or damaged, replace them at once. See your local dealer for replacements.

These labels are easily applied and will act as a constant visual reminder to you, and others who may use the equipment, to follow the safety instructions necessary for safe, effective operation.

⚠ DANGER



ROTATING BLADES CUT OFF ARMS AND LEGS

STOP MOWER WHEN CHILDREN ARE NEAR.

NO RIDERS — THEY FALL OFF.

OPERATION

To Start Engine

- Seat must be occupied.
- Traction Lever must be in Neutral.
- Clutch/Brake pedal must be fully depressed.
- PTO switch must be off.

Ignition Switch
OFF RUN
START

When Operator Leaves Seat

- Engine will shut off when Traction Lever is in Forward or Reverse, or when PTO switch is on.

Traction Control

- To stop tractor motion, fully depress the Clutch/Brake pedal.
- On Hydrostatic drive riders, movement of Traction Lever from Neutral, in either direction, increases ground speed.

To Operate PTO clutch

- The operator must be in the seat.
- To engage PTO, pull PTO switch out.
- To disengage PTO, push PTO switch in.

PTO Switch

(P) Parking Brake

To Set Parking Brake

- Pull knob out while Clutch/Brake pedal is depressed.
- Release Clutch/Brake pedal while holding knob.

To Release Parking Brake

- Depress Clutch/Brake pedal.
- Push knob down while Clutch/Brake pedal is depressed.

Clutch/Brake Pedal

Mower Height Adjust

- Push level forward to raise mower deck up.
- Pull lever back to lower mower deck.

Mower Down Mower Up

⚠ DANGER



OPERATING ON SLOPES CAN BE DANGEROUS

SEE OPERATOR'S MANUAL.

IF YOU CANNOT BACK-UP A HILL — DO NOT DRIVE ON IT.

⚠ WARNING

AVOID SERIOUS INJURY OR DEATH

- READ OPERATOR'S MANUAL(S).
- KNOW LOCATION AND FUNCTION OF ALL CONTROLS.
- KEEP SAFETY DEVICES (GUARDS, SHIELDS, & SWITCHES) IN PLACE AND WORKING.
- REMOVE OBJECTS THAT COULD BE THROWN BY THE BLADE.
- DO NOT MOW WHEN CHILDREN OR OTHERS ARE AROUND.
- NEVER CARRY CHILDREN.
- LOOK DOWN AND BEHIND—BEFORE AND WHILE BACKING.
- AVOID SUDDEN TURNS.
- IF YOU CANNOT BACK UP A HILL — DO NOT OPERATE ON IT.
- GO UP AND DOWN SLOPES, NOT ACROSS.
- IF MACHINE STOPS GOING UPHILL, STOP BLADE AND BACK DOWN SLOWLY.
- BE SURE BLADE(S) AND ENGINE ARE STOPPED BEFORE PLACING HANDS OR FEET NEAR BLADE(S).
- WHEN LEAVING MACHINE, SHUT OFF ENGINE, REMOVE KEY, AND SET PARKING BRAKE.

DO NOT TOW UNIT!
Damage may result to transmission.

Decal - Operating Information
Part No. 1713490

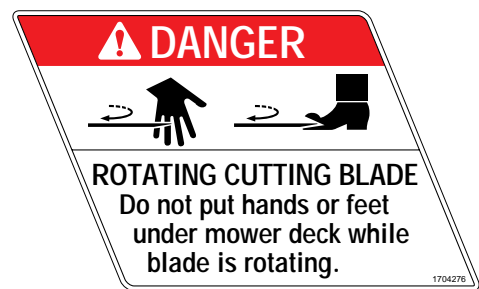

Decal - Danger
Part No. 1704276



Decal - Danger
Part No. 1704277

Features & Controls

RIDER FEATURES & CONTROLS

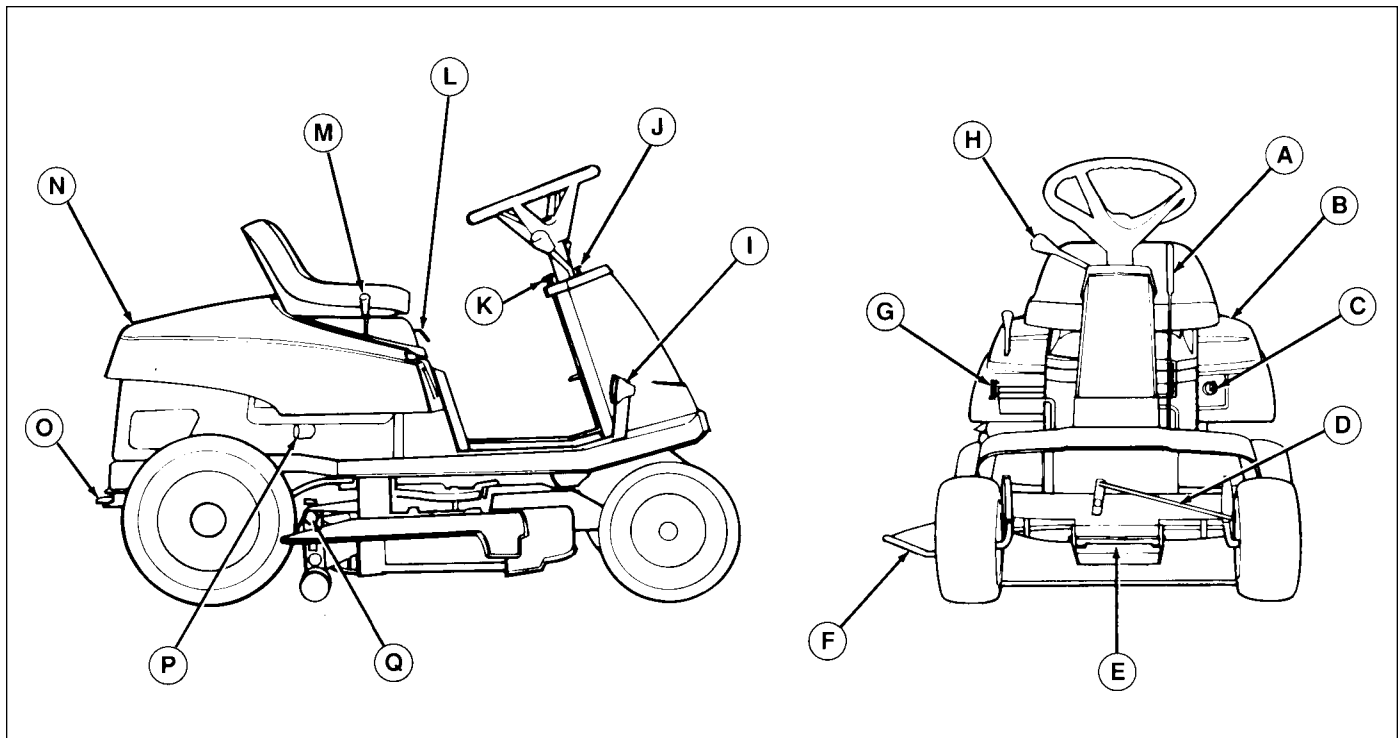

Figure 2. Rider Features

REF	NAME	FUNCTION
A	Mower Lift Lever	Raises mower into transport position.
B	Fuel Tank	2 gal. (7.6L) see-through tank for fuel level reading.
C	Ignition Switch	Starts and stops the engine.
D	Auto-Levelling Rod™	Allows mower hitch (E) to raise and lower around very tight corners while mower remains level.
E	Mower Hitch	Quick-hitch system allows easy removal and installation of mower and attachments
F	Mower Deflector	Deflector is a necessary safety device to control objects thrown from the deck. Never mow without deflector in place.
G	PTO (Electric Clutch) Switch	Controls electric clutch for attachments. Pull out to engage PTO; push in to disengage PTO.
H	Ground Speed Control Lever	Controls ground speed and forward/reverse motion. Push forward to go forward; pull back to go in reverse. On hydro models, ground speed is controlled by how far lever is in forward or reverse position.
I	Clutch/Brake Pedal	Press down to disengage clutch and apply brake. For parking brake, depress pedal fully and pull up on parking brake control knob (J).
J	Parking Brake Control Knob	Engages parking brake. Depress clutch/brake pedal (I) fully and pull up knob to engage parking brake. To disengage brake, depress pedal and push knob down.
K	Dial-A-Cut Control™	Adjusts height of mower cut.
L	Seat Adjustment Lever	Automotive-style lever to allow seat to slide forward and backward.
M	Engine Throttle/Choke Lever	Push forward to increase engine RPM. Push all the way forward for choke position.
N	Seat Deck	Lightweight polymer-alloy deck lifts up for easy access to engine compartment.
O	Drawbar	For use with utility carts or rear-mounted attachments, such as Twin Bag Grass Catcher.
P	Engine Muffler	Exhausts hot air to the right side away from the fuel tank. Use caution around the heat shields and muffler until hot surfaces cool after operation.
Q	Mower Levelling Nut	Allows for the accurate side-to-side levelling of mower deck.

ENGINE COMPARTMENT

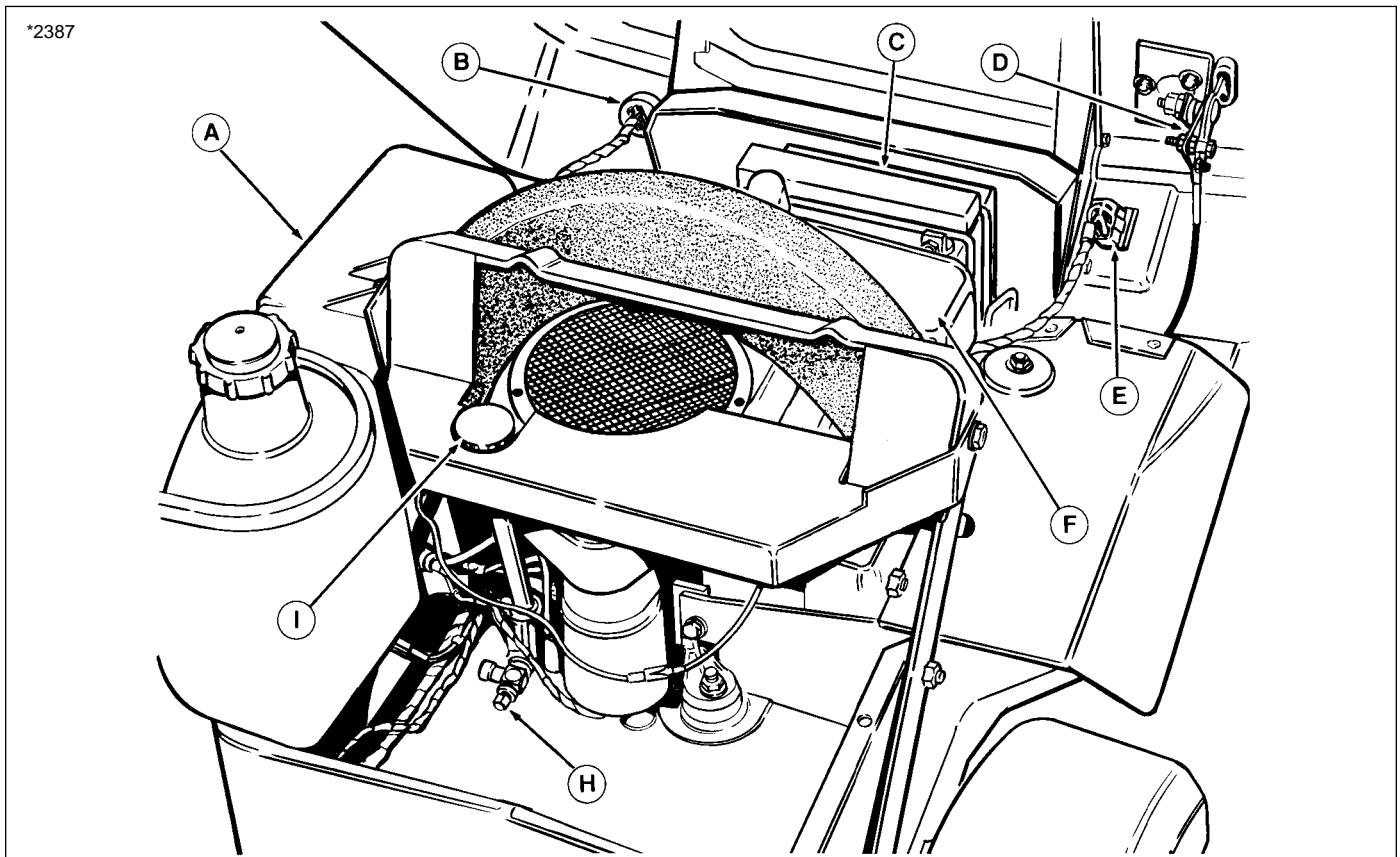

Figure 3. Engine Compartment

REF	NAME	FUNCTION
A	Fuel Tank	2 gal. (7.6L) see-through tank for fuel level reading.
B	Ignition Switch	Starts and stops the engine.
C	Battery	12 volt, 340 amp battery recharged by engine alternator
D	Throttle/Choke Cable	Controls engine speed and choke position. See engine manual for adjustment.
E	PTO Switch (Electric Clutch)	Controls electric clutch for attachments. Pull out to engage clutch; push in to disengage.
F	Air Filter	See engine manual for maintenance instructions.
G	Oil Fill/Dipstick	Turn and remove to check or add oil. See engine manual for dipstick instruction.
H	Oil Drain	Attach clear plastic tube to drain outlet and open valve to drain oil.
Not Shown	Fuel Filter	In-line filter for straining particles in fuel lines and fuel tank.

Features & Controls

SAFETY INTERLOCK SYSTEM

Your rider is equipped with a seat switch safety system that will automatically shut the engine off when the operator leaves the seat with the ground speed control lever in gear or PTO engaged. Once the engine has stopped, the electric PTO switch must be turned off after operator returns to the seat in order to start the engine.

On hydro models, the clutch/brake pedal (1, figure 2) must be fully depressed to start engine.

Check the seat switch every fall and spring with the tests listed below.

With operator in seat and ignition switch turned to ON (engine not running):

 **WARNING**

If the rider does not pass the test, do not operate rider. See your authorized dealer. Under no circumstance should you attempt to defeat the purpose of the safety system.

Test 1 - Engine should NOT crank if:

- A. seat is not occupied or
- B. transmission lever out of neutral or
- C. PTO switch engaged or
- D. clutch/brake pedal not fully depressed.

Test 2 - Engine should crank if:

- A. seat is occupied and
- B. transmission lever is in neutral and
- C. PTO switch is disengaged and
- D. clutch/brake pedal is fully depressed.

Test 3 - Engine should shut off if:

- A. operator rises off seat with transmission lever in gear or
- B. operator rises off seat with clutch/brake pedal not depressed (parking brake on) or
- C. operator rises off seat with PTO engaged.

NOTE: If operator returns to seat before engine stops, the engine will re-start and electric PTO clutch will re-engage.

Test 4 - PTO will disengage if:

- A. operator rises off seat with engine running.

NOTE: If operator returns to seat before engine stops, the engine will resume speed and electric PTO clutch will re-engage.

GENERAL

Before operating this rider for the first time, the owner should operate in an open area without mowing, to become accustomed to the unit. The left side of the mower can be used to trim close to objects. Be sure to read all information in the Safety and Operation sections before attempting to operate this rider and mower.

⚠ WARNING - SLOPE OPERATION

Never operate on slopes greater than 30 percent (16.7°) which is a rise of three feet vertically in 10 feet horizontally. When operating on slopes that are greater than 15 percent (8.5°) but less than 30 percent use front counterweights and rear wheel weights (see your dealer). Select slow ground speed before driving onto slope. In addition to front and rear weights, use extra caution when operating on slopes with rear-mounted grass catcher. Mow UP and DOWN the slope, never across the face, use caution when changing directions and **DO NOT START OR STOP ON SLOPE.**

⚠ WARNING

Never allow passengers to ride on the unit.

⚠ WARNING

Towing the rider will cause transmission damage. Do not use another vehicle to push or pull rider .

⚠ WARNING

To reduce fire hazard, keep the engine and mower free of grass, leaves and excess grease.

⚠ WARNING

The interlock safety switches are for your safety. Do not attempt to bypass them.

MOWER REMOVAL AND INSTALLATION

⚠ WARNING

Stop engine and remove key. Do not engage PTO until mower is completely removed or installed and operator is seated.

NOTE: Perform mower installation on a hard, level surface such as a concrete floor. For easier mower removal and installation, rear trailing arms (F, figure 5) can be removed by removing spring clips and clevis pins.

1. Park rider and turn off PTO switch and engine, remove the key and apply parking brake. Turn the wheels fully to the left.

*2396

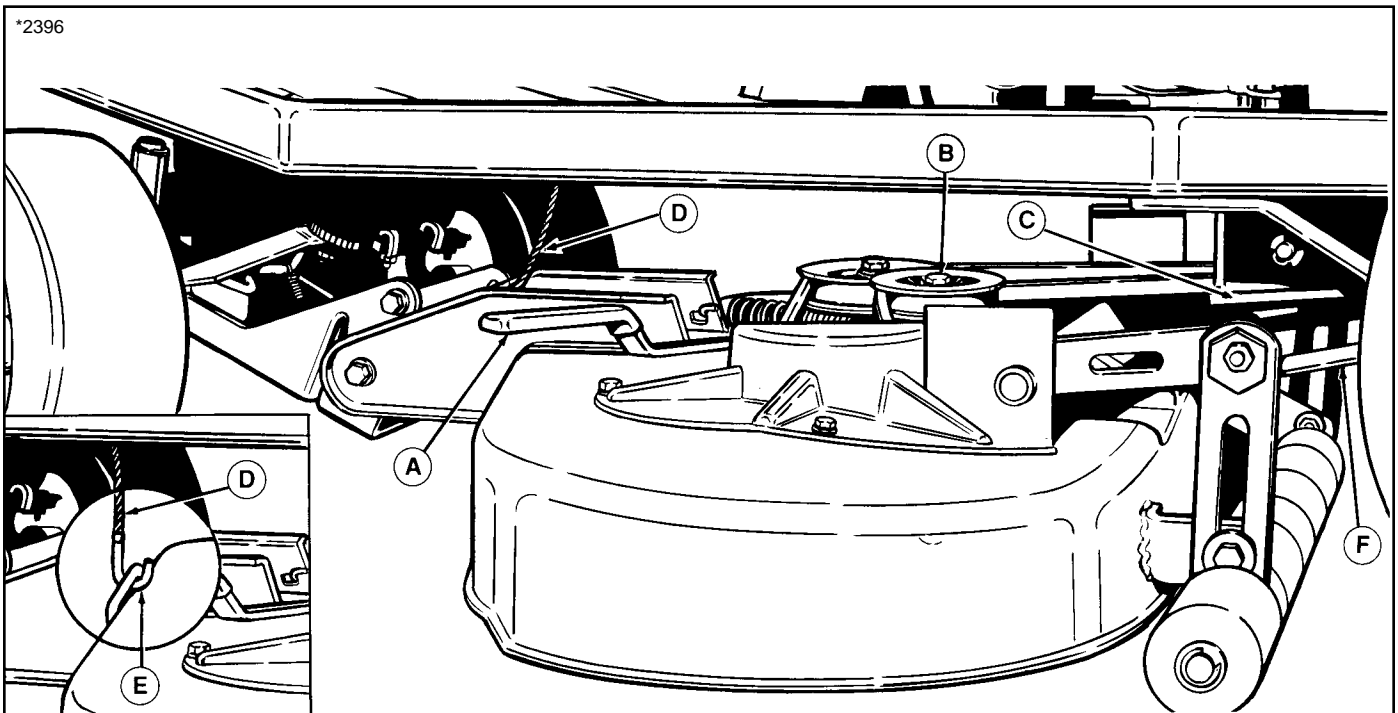

Figure 5. Mower Removal/Installation (34" mower shown)

- | | |
|---------------------------------|-----------------------|
| A. Idler Pulley Arm | D. Lift Cable |
| B. Idler Pulley | E. Lift Hook |
| C. PTO (Electric Clutch) Pulley | F. Rear Trailing Arms |

Operation

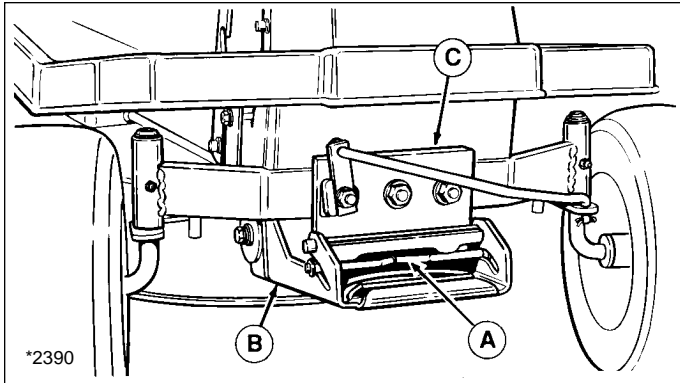

Figure 6. Mower Hitch

- A. Lever
- B. Mower Hitch
- C. Rider Hitch Brackets

2. On left-hand side of 34" mower, push idler pulley arm (A, figure 5) to relieve belt tension.
On right-hand side of 30" mower, pull idler pulley arm to relieve belt tension.
3. With belt tension relieved, remove belt from idler pulley (B, figure 5) and PTO pulley (C). Removing belt relieves tension on the front hitch assembly.
4. With lift lever down and Dial-A-Cut™ control set to the lowest setting, remove lift cable (D, figure 5) from mower hook (see inset illustration, figure 5).
5. Remove mower hitch (B, figure 6) from rider hitch brackets (C) by pulling spring-loaded lever (A, figure 6) forward and lifting up on hitch. Place mower hitch on ground.
6. With wheels turned fully left, remove mower from underneath right-hand side of rider.
7. To install mower, reverse above steps. Check mower belt pattern as shown in figure 7. Make sure that the mower lift cable is installed with hook toward the rear and rear trailing arms (F, figure 5) are positioned above rear torsion bar.

OPERATING THE MOWER

1. When traveling to or from the work site, fully raise the mower using the mower lift lever (A, figure 11). At the work site, lower mower using the lift lever.
2. Use the Dial-A-Cut™ control (E, figure 11) to adjust the height of the mower. Pull back slightly on mower lift lever (A, figure 10) to relieve pressure and turn clockwise to raise mower cutting height, or counter-clockwise to lower cutting height.

NOTE: Cutting height scale is located on the quadrant at base of lift lever. Scale is numbered 1 thru 4, with 4 representing the highest cutting height.

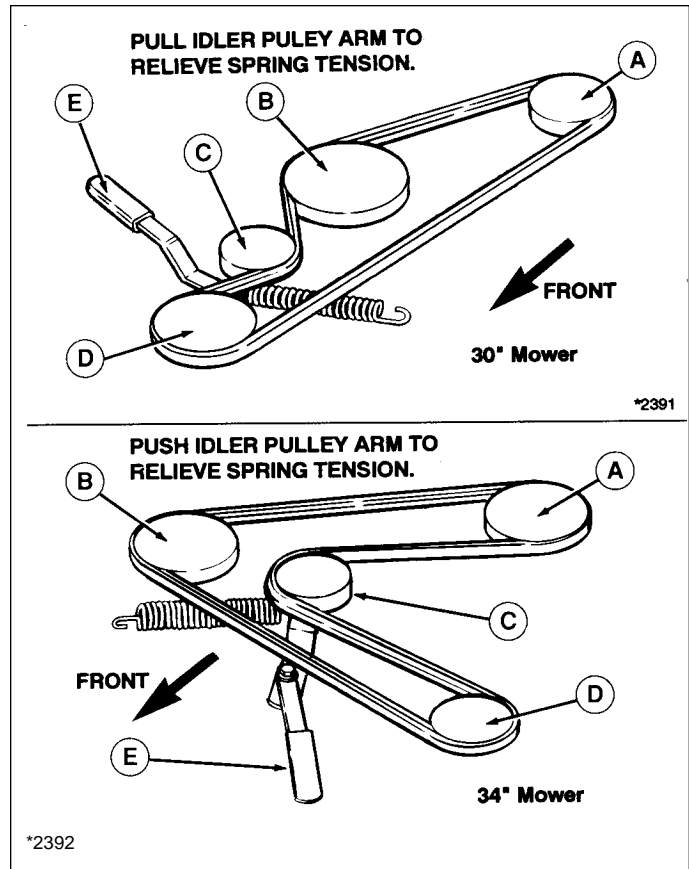

Figure 6. Mower Belt Pattern

- A. PTO (Electric Clutch (Pulley)
- B. Arbor Pulley (30")
Right Arbor Pulley (34")
- C. Idler Pulley
- D. Front Idler Pulley (30")
Left Arbor Pulley (34")
- E. Idler Pulley Arm

CHECKS BEFORE STARTING

1. Make sure you have proper wheel or counterweights if required. See SLOPE OPERATION in the Safety Rules section. Make sure any slopes are within required limits.
2. Check that crankcase is filled to full mark on dipstick. See the engine Operator's Manual for instructions and oil recommendations.
3. Make sure all nuts, bolts, screws and pins are in place and tight.
4. Make sure you can reach all controls from operator's positions. If not, see SEAT ADJUSTMENT.
5. Fill the gasoline tank with fresh gasoline. Fill to bottom of filler neck to avoid spillage and overflow. **DO NOT** mix oil with gasoline. Refer to engine manual for gasoline recommendations.

WARNING

Gasoline is highly flammable and must be handled with care. Never fill the tank when the engine is still hot from recent operation. Do not allow open flame, smoking or matches in the area. Avoid over-filling and wipe up any spills.

CLUTCH/BRAKE PEDAL OPERATION - HYDRO MODELS

1. See figure 10. Depressing the pedal from position A to B disengages the transmission drive and also returns the transmission control lever to neutral (from forward speeds). Fully depressing the pedal to position B applies the rider brake.
2. Parking brake is applied at pedal position B when parking brake control knob (C, figure 10) is pulled up with pedal fully depressed.

CLUTCH/BRAKE PEDAL OPERATION - GEAR MODELS

1. See figure 10. Depressing the clutch pedal from position A to B activates neutral start circuit, disengages the transmission drive belt and allows the gear lever to be shifted.
2. Fully depressing the clutch/brake pedal from position A to B applies the rider brake. Parking brake is applied at position B when parking brake control knob (C, figure 10) is pulled up with pedal depressed.

STARTING THE ENGINE

1. Seat yourself on the rider seat in the operating position. Set the parking brake using the clutch/brake pedal (D, figure 11) and parking brake knob (B).
2. Push down on the switch (G, figure 2) to disengage the PTO and place the ground speed control lever (C, figure 11) in neutral.
3. For cold starts, set the engine speed control (M, figure 2) to the choke position. For warm starts, set engine speed control lever at 1/2 throttle position .
4. Turn the key (C, figure 2) to start and release when engine has started.
5. Move the engine speed control lever (M, figure 2) to the slow position. Warm up the engine by running it for at least a minute before engaging the PTO or driving the rider .

SELECTING GROUND & ENGINE SPEED

On hydro models, ground speed is infinitely variable

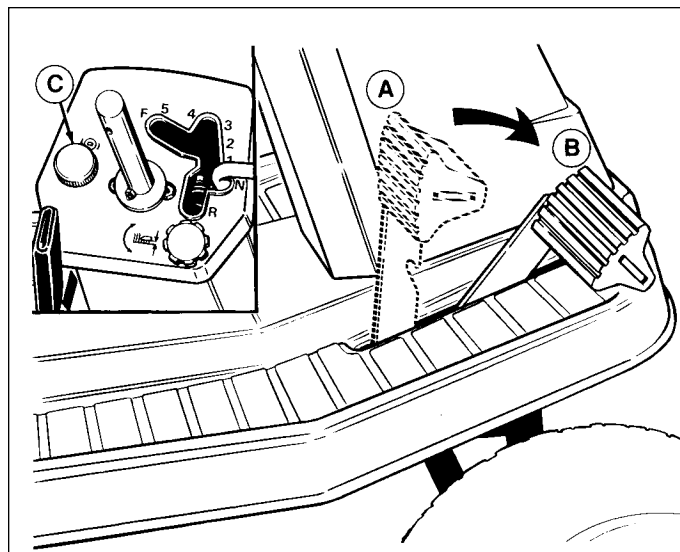

Figure 10. Clutch/Brake Pedal

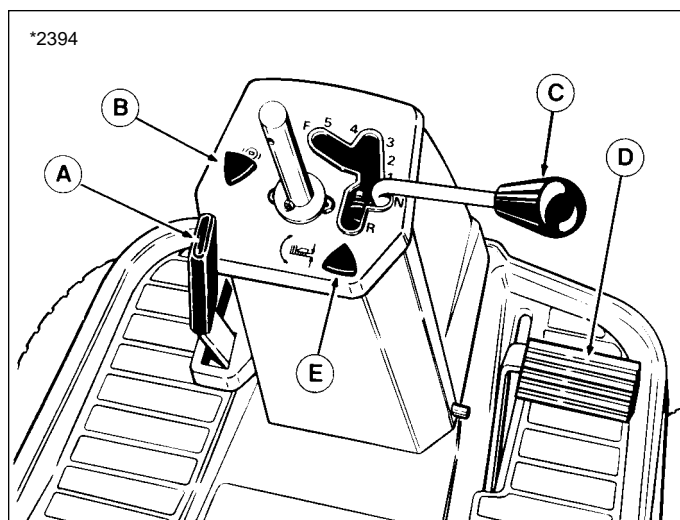

Figure 11. Controls

- A. Mower Lift Lever
- B. Parking Brake Knob
- C. Ground Speed Control Lever
- D. Clutch/Brake Pedal
- E. Dial-A-Cut™ Control

according to how far the control lever (C, figure 11) is moved in the forward or reverse position.

On gear models, ground speed is selected by depressing the clutch/brake pedal (D, figure 11) and moving the control lever (C, figure 11) to the appropriate gear selection. Most mowing is done in 3rd or 4th gear with engine set at full speed. If the terrain is rough, hilly or sloping, use first or second gear. If the grass is wet or over 3" (76mm) high, use full engine speed (with low gear) so the mower will have enough power to cut the grass.

Operation

⚠ WARNING

Make sure desired direction of travel is clear of objects, people and animals.

1. If you are ready to mow, lower the mower from the transport position using lever (A, figure 11) and set the mowing height using the Dial-A-Cut™ Control (E, figure 11).
2. Set the engine speed control lever (M, figure 2) for full speed.
3. Use the PTO switch (G, figure 2) to engage the PTO.
4. Release the parking brake by depressing the clutch/brake pedal (D, figure 11) and pushing knob (B) down.
5. **On hydro models**, move the ground speed control lever (C, figure 11) to the desired direction and speed of travel to set the rider in motion.
On gear models, depress clutch/brake pedal, use the ground speed control lever to select the proper gear for conditions, then slowly release clutch/brake pedal to set the rider in motion.
6. Adjust engine speed control lever (M, figure 2) to the desired speed. Between 3/4 and full speed is recommended for mowing.

⚠ WARNING

Before leaving the operator's position for any reason, engage the parking brake, disengage the PTO, stop the engine and remove the key.

STOPPING THE RIDER

1. **On hydro models**, move the ground speed control lever (C, figure 11) into the NEUTRAL position to make a gradual stop. To make a more rapid stop, depress the clutch/brake pedal (D, figure 11).
NOTE: On hydro models, the ground speed control lever will return to neutral from forward automatically when the clutch/brake pedal is depressed.
On gear models, press the clutch/brake pedal (D, figure 11) down only far enough to disengage the clutch to make a gradual stop. For a more rapid stop, press pedal down farther to apply the brake. Move the ground speed control lever to NEUTRAL before releasing the pedal.
2. Engage the parking brake by fully depressing clutch/brake pedal and pulling up on parking brake knob (B, figure 11).

⚠ WARNING

To reduce fire hazard, keep the engine, rider and mower free of grass, leaves and excess grease. Do not stop or park rider over dry leaves, grass or combustible materials.

3. Use the PTO switch (G, figure 2) to disengage the PTO.
4. Set the engine speed control lever (M, figure 2) to 1/2 throttle setting and allow the engine to idle for 20 seconds. Stopping a hot engine too fast may cause engine damage.
5. Turn key (C, figure 2) to OFF and remove it.

NEUTRAL SAFETY CHECKS

NEUTRAL GATE CHECK: The unit should not move when the ground speed control lever is in the neutral gate.

RETURN-TO-NEUTRAL CHECK: On Hydrostatic equipped models, the ground speed control lever should return to the neutral gate when the clutch/brake pedal is fully depressed.

If the unit fails either of these checks, the unit should be properly readjusted by an authorized servicing dealer before use.



Do not tow the rider.
Damage will result to the transmission/axle.

PUSHING THE RIDER BY HAND

Hydro Models

1. Engine should be off and ignition key removed.
2. Place the mower in the transport position (up) using the mower lift lever (A, figure 11).
3. See figure 12. To push the rider by hand, the release lever must be placed in the PUSH position.
4. To drive the rider, release lever must be moved to the DRIVE position.

Gear Model

1. Engine should be off and ignition key removed.
2. Place the mower in the transport position (up) using the mower lift lever (A, figure 11).
3. Depress the clutch/brake pedal and place the ground speed control lever (C, figure 11) in the neutral gate.
4. Unlock the parking brake.

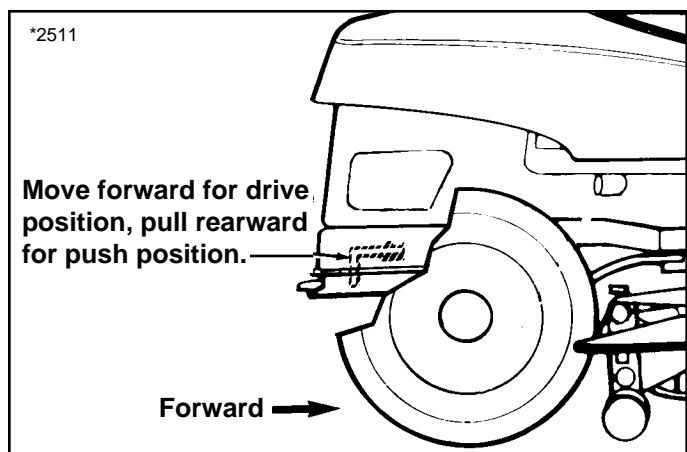

Figure 12. Transaxle Release Lever - Hydro Models

GENERAL

For the first use of the mower, choose a smooth level area. Cut long straight strips overlapping slightly.

The size and type of area to be mowed determines the best mowing pattern to use. Obstructions such as trees, fences and buildings must also be considered. Where possible, make one or two passes in a counterclockwise direction around the outside of the area to keep the cut grass off fences and walks. The remainder of the mowing should be done in a clockwise direction so the clippings are dispersed on the cut area.

Keep in mind the following lawn care and mowing tips:

- Too much maintenance is as detrimental to your lawn as neglect.
- Mow when grass is 3-5 inches tall. Don't cut shorter than 2 to 2-1/2 inches. Cut only the top one-third of the grass blade. Cutting below this level can lead to thatch problems. Your mower has a cutting height adjustment that can help you maintain a proper length.
- For extremely tall grass, set the cutting height at maximum for the first pass, and then reset to the desired height and mow again.
- Mow often. Short clippings of an inch or less decompose more quickly than longer blades.
- Keep the blades on your mower sharp for finer clippings.
- Let grass grow a bit longer when it is hot to reduce heat build-up and protect grass from heat damage.
- Use slow-release fertilizer for slow, even growth.
- Don't cover grass surface with a heavy layer of clippings. Consider using a grass collection system and starting a compost pile.
- Aerate lawn in spring, consider renting an aerator which removes cores of soil from the lawn. This increases the speed of clipping decomposition and deep root growth by opening up the soil and permitting greater movement of water, fertilizer and air.
- Don't over-water. Too much water can encourage disease development.
- Mow when the grass is dry, preferably in the late afternoon when the temperatures are cooler.
- Where possible, change patterns occasionally to eliminate matting, graining or a corrugated appearance.
- For wet grasses, grasses prone to wheel tracking and for collecting clippings:
 - a. Use sharp blades.
 - b. Raise deck 1/4" higher in front than in rear.
 - c. Run at maximum engine speed but slow ground speed.
 - d. Clean deck of built-up material/caked-on grass.
 - e. Check for free movement of mower idler pulley.

- For dry conditions where grass blow-out is a problem:
 - a. Use sharp blades.
 - b. Raise deck so the front is even with, or 1/8" lower than, rear.
 - c. Use 3/4 engine speed.
 - d. Clean deck of built-up material/caked-on grass.

MULCHING MOWER OPERATION (OPTIONAL KIT ATTACHMENT)

Mulching

Mulching consists of actually cutting and recutting clippings into tiny particles and blowing them into the lawn. These tiny particles decompose rapidly into by-products your lawn can use. Under proper conditions, your mulching mower will virtually eliminate noticeable clippings on the lawn surface.

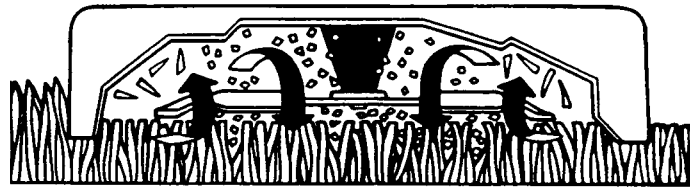

Keep in mind these mulching tips:

- Use mulching mower or mulcher kit without shredders for grass mulching.
- Install shredders for leaf shredding.
- Use maximum engine speed.
- Raise height of cut if excessive power is used.
- Must use sharp blades. Do not use lift tabs or high lift blade when mulching.
- Adjust to lower ground speeds in heavy grass or if windrow is present.
- Clean deck of built-up material/caked-on grass.
- Check for free movement of mower idler pulley.

Mowing Conditions

The best mulching results from mowing when lawn is dry and grass blades are not over 5" long. Follow these guidelines for best results:

- Do not use the mower as a mulching mower during the first two or three mowings in the spring. The long grass blades, quick growth, and often wetter conditions are more suitable for side-discharge (broadcasting) or grass bagging operation.
- Avoid mulching after rain or heavy dew. It may be better to mow later in the day or early evening when lawn is drier.
- Change the mowing pattern each time.

Mowing Patterns & Tips

- If mulching baffles are removed, the original deflector must be in operating position for safe side-discharge mowing.

How Much Grass To Cut Off

Removing too much grass height in one cutting may result in an unsatisfactory cut: windrowing, clumping, or uneven dispersal of clippings may result. It is best to mow when the grass is between 3"- 5" tall, although this will depend on your personal preference for lawn appearance. A good rule to follow is to cut only the top one-third of the grass blade at a time (maximum of 1-1/2"). Cutting more off the grass blade, particularly in wet spring conditions, can lead to thatch problems.

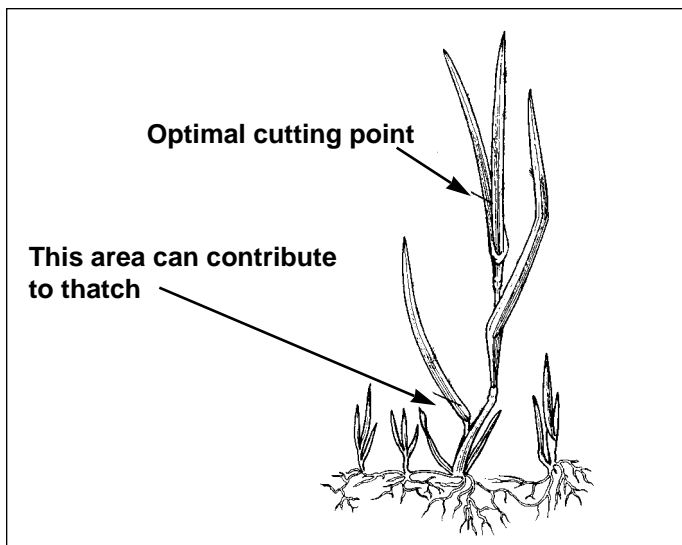

Engine Speed & Ground Speed

Use full engine throttle matched with a slower ground speed so that clippings will be finely cut. A better cut may result from cutting the same area in two passes, each time cutting only 3/4" of grass blade. Short clippings of 1" or less decompose more quickly than longer blades.

NOTE: When mulching under heavy cutting conditions, a rumbling sound may be present and is normal.

The Proper Equipment

Always keep the mower blades sharp and balanced. Blades should be sharpened at the beginning of every mowing season. If the tips of grass blades brown after cutting, this may be a sign of dull blades tearing, rather than cutting, the grass blades.

Keep the underside of the mower deck and baffles clean so that clippings are properly circulated, chopped, and discharged back into the lawn.

The Best Combination

We recommend that you experiment with the height of cut position and rider ground speed that will give you the best cut. Start with a higher cutting height and try increasing lower settings until you find a cutting height that is matched to your mowing conditions and preferences. Since mulching requires more horsepower than side-discharging, using a slower ground speed is important for proper mulching operation.

Clippings Are Beneficial

A common misconception about clippings is that they automatically lead to thatch. However, clippings produced by mulching methods actually contribute to a healthy lawn because they:

- Act as a safe, non-polluting and inexpensive fertilizer that nourishes your lawn. Fresh cut blades are a rich source of nitrogen which is essential to lush growth. And one garbage bag of clippings contains about 1/4 lb. of usable organic nitrogen.
- Reduce the evaporation of water from your lawn.
- Provide a cushioning layer to reduce lawn wear.
- Moderate soil temperature.
- Save money normally spent on trash bags.

Leaf Shredding - 34" Mower Deck Only (For use with Mulcher Kit Only)

Patented Shredder Blades virtually eliminate raking leaves. Up to 512 cutting edges pulverize leaves into tiny particles, which quickly and naturally decompose into food for your lawn. Shredder Blades must be removed when you choose to mulch grass clippings.

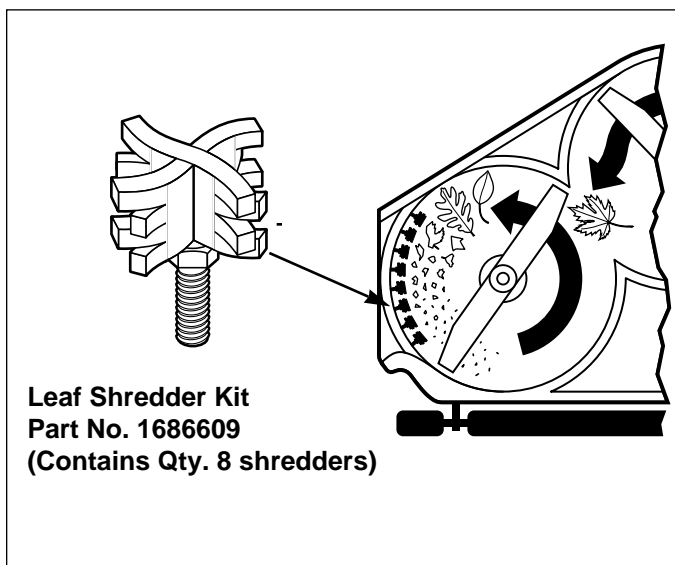

SCHEDULE

The following schedule should be followed for normal care of your rider and mower. You will need to keep a record of your operating time. Determining operating time is easily accomplished by multiplying the time it takes to do one job by the number of times you've done the job, or you can install the optional hour meter.

Safety Items	See Page	Before First Use	Before Each Use	Every 5 Hours	Every 25 Hours	Every 100 Hours	Spring & Fall
Check safety interlock system.	8	●					●
Check rider brakes.	26	●					●
Check mower blade stopping time.	30	●				●	
Normal Care Items							
Check rider & mower for loose hardware.	–	●	●	●			
Check engine oil level.	*	●	●	●			●
Check engine & air filter.	*				***●		
Change engine oil and filter.**	*					***Every 50 hrs.	***●
Lubricate rider & mower.	17				***●		
Check fluid levels & tire pressure	16	●	●		**●		
Change transmission fluid. (Hydro only)****	–	Only if transaxle is serviced.					
Check fuel filter.	16					●	
Clean battery & cables	18					●	
Clean/sharpen blades.	18					●	
Inspect spark plug(s).	*					●	

* See the engine manufacturer's owner's manual.

** Change original engine oil after first 5 hours of operation.

*** More often in hot (over 85° F: 30° C) weather or dusty operating conditions.

**** Transaxle is a sealed unit and requires no regular interval fluid changes.

RAISING THE SEAT DECK

To gain access to the engine compartment, simply raise the seat deck forward.

CHECKING/ADDING GASOLINE

Check the gas gauge/cap to be sure there is enough gasoline to complete the job. To add gasoline, remove the gas gauge/cap. Do not overfill. Leave room in the tank for fuel expansion. Refer to your engine manual for gasoline recommendations. Install and hand tighten the gas gauge/cap.

CAUTION

Never use gasoline containing METHANOL, gasohol containing more than 10% ethanol, gasoline additives, premium gasoline, or white gas because engine/fuel system damage could result.

CHECKING TIRE PRESSURE

Front and rear tire pressure should be 10 to 12 psi (68 to 82 kPa)

CHECKING FUEL FILTER

WARNING

Do not remove fuel filter when engine is hot, as spilled gasoline may ignite. DO NOT spread hose clamps further than necessary. Ensure clamps grip hoses firmly over filter after installation.

The fuel filter is located in fuel line between fuel tank and carburetor. If filter is dirty or clogged, replace as follows. Place a container below filter to catch spilled gasoline.

1. Using a pliers, open and slide hose clamps from fuel filter.
2. Remove hoses from filter.
3. Install new filter in proper flow direction in fuel line. Secure with hose clamps. See warning at beginning of procedure.

Normal Care

LUBRICATION

Lubricate the rider and mower as shown in figures 13 - 18. When a grease gun is shown, wipe the fitting clean, apply two or three shots of lithium base automotive

grease, and wipe off excess grease. When an oil can is shown, wipe the area clean, apply a few drops of oil (SAE 30), then wipe up drips or spills.

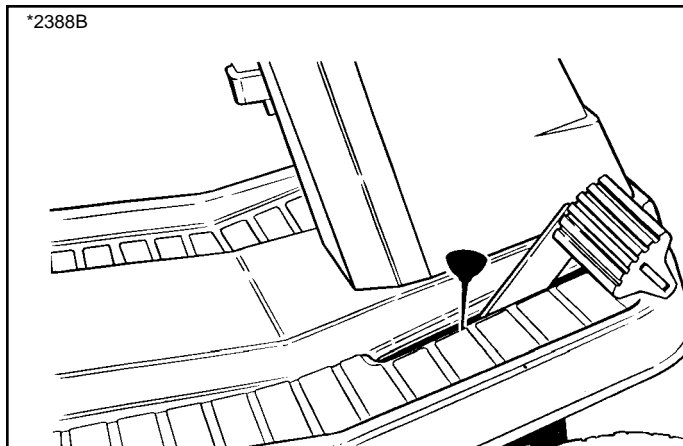

Figure 13. Brake Pedal Pivot Point

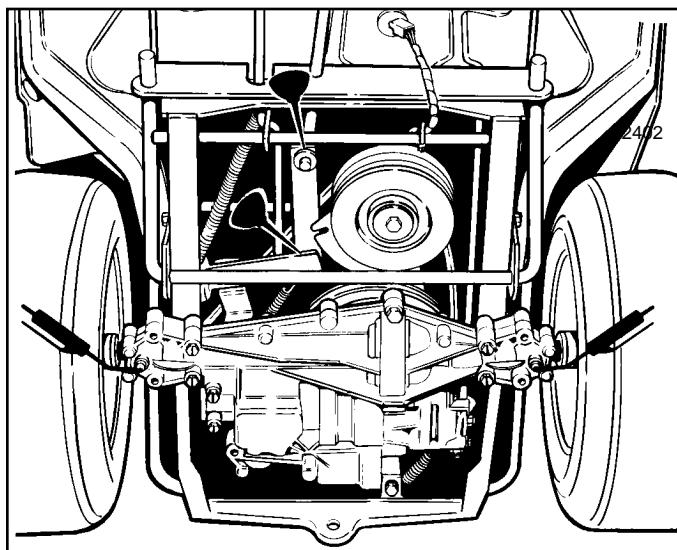

Figure 16. Rider Lubrication Points - Rear Half (Gear Model Shown)

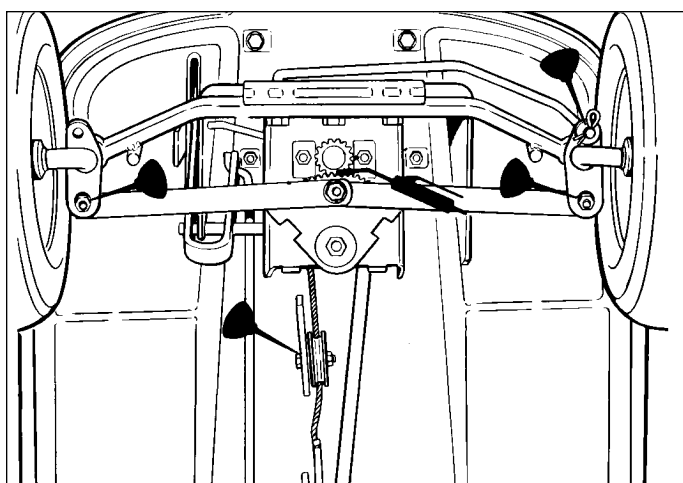

Figure 14. Rider Lubrication Points - Front Half

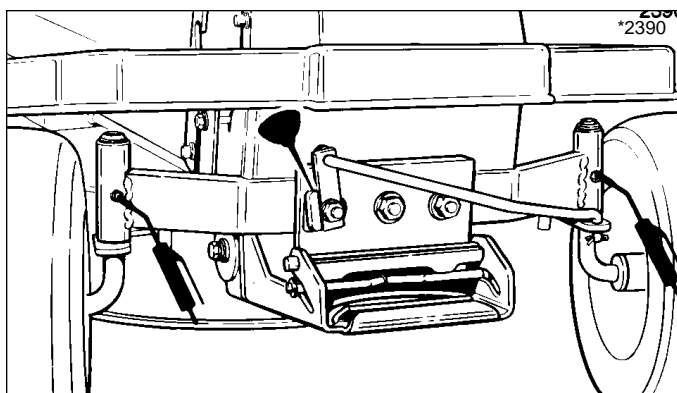

Figure 17. Front Axle Lubrication Points

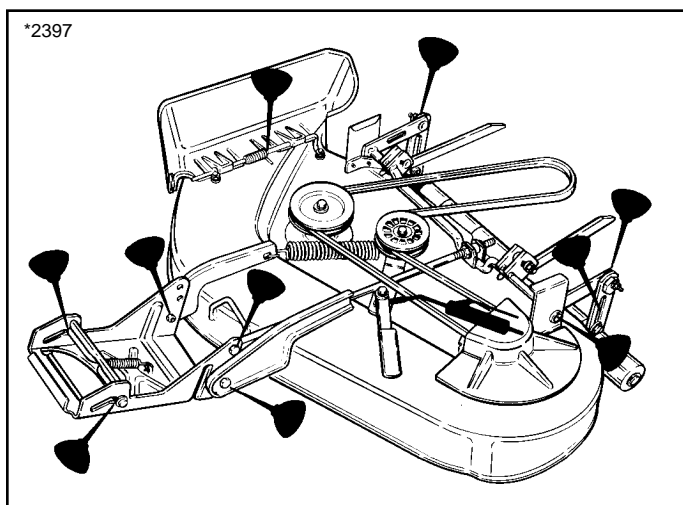
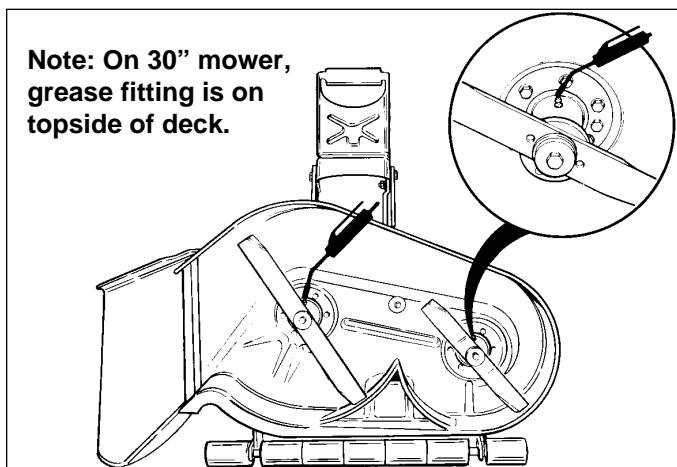

Figure 15. Front Axle Lubrication Points



Note: On 30" mower, grease fitting is on topside of deck.

Figure 18. Arbor Lubrication Points

BATTERY MAINTENANCE

Checking the Battery Fluid

1. Raise the seat deck.
2. Remove battery filler cap. Fluid must be even with split ring full mark. If not, add distilled water.
3. Reinstall filler cap.

⚠ WARNING

Be careful when handling the battery. Avoid spilling electrolyte. Keep flames and sparks away from the battery.

Cleaning the Battery and Cables

⚠ WARNING

When removing or installing battery cables, disconnect the negative cable FIRST and reconnect it LAST. If not done in this order, the positive terminal can be shorted to the frame by a tool.

1. Disconnect the cables from the battery, negative cable first (B, figure 19).
2. Remove the battery clamp, then remove the battery.
3. Scrub the battery, cables and battery compartment with baking soda and water.
4. Clean the battery terminals and cable clamps with a wire brush and battery post terminal cleaner.
5. Reinstall battery and clamp.
6. Connect cables, positive cable first.
7. Coat cable clamps and terminals with grease or petroleum jelly.

SERVICING THE MOWER BLADES

⚠ WARNING

For your personal safety, do not handle the sharp mower blades with bare hands. Careless or improper handling of blades may result in serious injury.

1. Remove mower from the rider.
2. Blades should be sharp and free of nicks and dents. If not, sharpen blades as described in following steps.

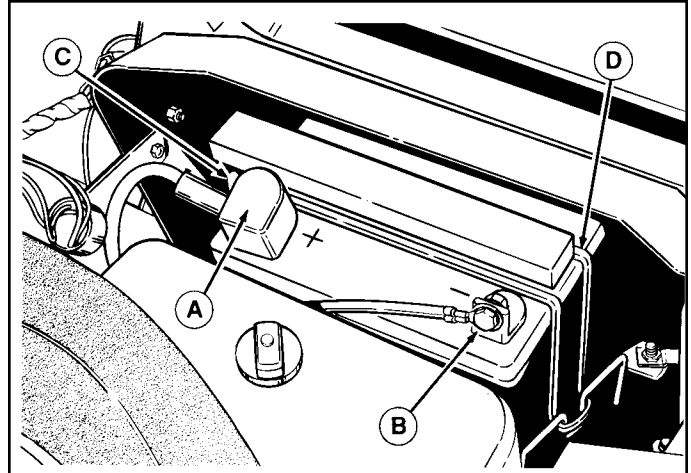

Figure 19. Battery
 A. Positive Battery Terminal C. Vent Tube
 B. Negative Battery Terminal D. Holddown Strap

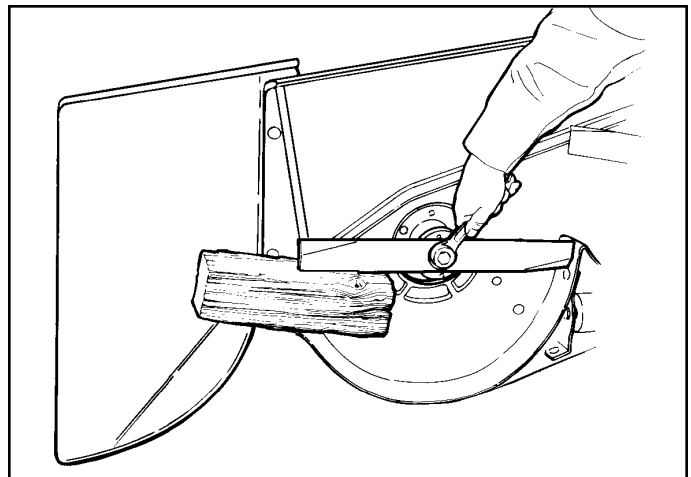

Figure 20. Removing The Blade

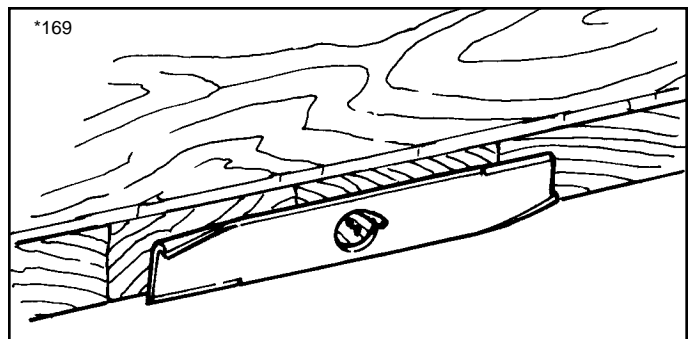

Figure 21 Balancing The Blade

Normal Care

- To remove blade for sharpening, use wooden block to hold blade while removing the blade mounting cap-screw (figure 20).
- Use a file to sharpen blade to fine edge. Remove all nicks and dents in blade edge. If blade is severely damaged, it should be replaced.
- Balance the blade as shown in figure 21. Center the blade's hole on a nail lubricated with a drop of oil. A balanced blade will remain level.
- Reinstall each blade with the tabs pointing up toward deck as shown in figure 22. Secure with a capscrew (D), cup washer (C) and spline washer (B). Use a wooden block to prevent blade rotation and torque capscrews to 50-70 ft.lbs. (67-95 N.m.).

WARNING

For your personal safety, blade mounting cap-screws must each be installed with a cup washer and spline washer, then securely tightened. Torque blade mounting capscrew to 50-70 ft.lbs. (67-95 N.m.)

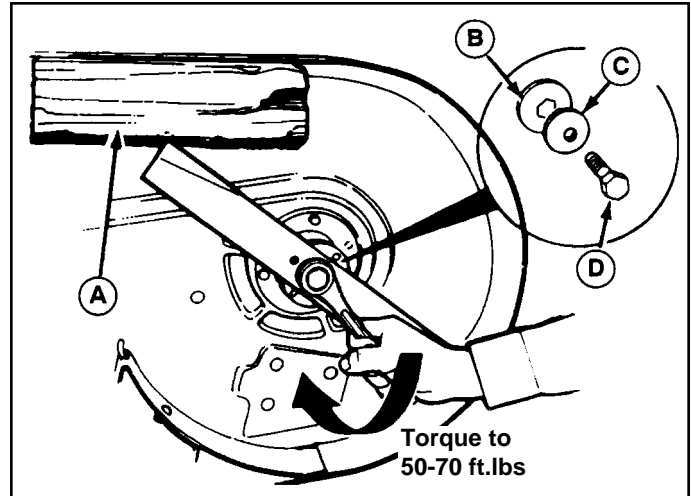

Figure 22. Installing The Blade

- | | |
|-----------------|---------------|
| A. Wooden Block | C. Cup Washer |
| B. Hex Washer | D. Capscrew |

⚠ WARNING

Never store the rider, with gasoline in engine or fuel tank, in a heated shelter or in enclosed, poorly ventilated enclosures. Gasoline fumes may reach an open flame, spark or pilot light (such as a furnace, water heater, clothes dryer, etc.) and cause an explosion.

Handle gasoline carefully. It is highly flammable and careless use could result in serious fire damage to your person or property.

Drain fuel into an approved container outdoors away from open flame or sparks.

TEMPORARY STORAGE (30 Days Or Less)

Remember, the fuel tank will still contain some gasoline, so never store the rider indoors or in any other area where fuel vapor could travel to any ignition source. Fuel vapor is also toxic if inhaled, so never store the rider in any structure used for human or animal habitation.

Here is a checklist of things to do when storing your rider temporarily or in between uses:

- Keep the rider in an area away from where children may come into contact with it. If there's any chance of unauthorized use, remove the spark plug (s) and put in a safe place. Be sure the spark plug opening is protected from foreign objects with a suitable cover.
- If the rider can't be stored on a reasonable level surface, chock the wheels.
- Clean all grass and dirt from the mower.

NOTE: If storing your rider between winter snow removal jobs in a cold area, we suggest that you fill the fuel tank at the completion of each job to prevent water condensation in the fuel tank. Wait for engine to cool before filling tank.

LONG TERM STORAGE (Longer Than 30 Days)

Before you store your rider for the off-season, read the Maintenance and Storage instructions in the Safety Rules section, then perform the following steps:

1. Drain crankcase oil while engine is hot and refill with a grade of oil that will be required when rider is used again.
2. Prepare the mower deck for storage as follows:
 - a. Remove mower deck from the rider.

- b. Clean underside of mower deck.
- c. Coat all bare metal surfaces with paint or light coat of oil to prevent rusting.
3. Clean external surfaces and engine.
4. Prepare engine for storage. See engine owner's manual.
5. Clean any dirt or grass from cylinder head cooling fins, engine housing and air cleaner element.
6. Cover air cleaner and exhaust outlet tightly with plastic or other waterproof material to keep out moisture, dirt and insects.
7. Completely grease and oil rider as outlined in the Normal Care section.
8. Clean up rider and apply paint or rust preventative to any areas where paint is chipped or damaged.
9. Be sure the battery is filled to the proper level with water and is fully charged. Battery life will be increased if it is removed, put in a cool, dry place and fully charged about once a month. If battery is left in rider, disconnect the negative cable.
10. Drain fuel system completely or add a gasoline stabilizer to the fuel system. If you have chosen to use a fuel stabilizer and have not drained the fuel system, follow all safety instructions and storage precautions in this manual to prevent the possibility of fire from the ignition of gasoline fumes. Remember, gasoline fumes can travel to distant sources of ignition and ignite, causing risk of explosion and fire.

NOTE: Gasoline, if permitted to stand unused for extended periods (30 days or more), may develop gummy deposits which can adversely affect the engine carburetor and cause engine malfunction. To avoid this condition, add a gasoline stabilizer to the fuel tank or drain all fuel from the system before placing unit in storage.

Storage

11. Transport the rider to a suitable, dry, indoor location. If the rider is to be stored 6 months or longer, block the rider up off the wheels to relieve weight and also to keep the tires off a damp floor. Protect tires from prolonged exposure to direct sunlight.

STARTING AFTER LONG TERM STORAGE

Before starting the rider after it has been stored for a long period of time, perform the following steps.

1. Remove the blocks from under the rider.
2. Install the battery if it was removed.
3. Unplug the exhaust outlet and air cleaner.
4. Fill the fuel tank with fresh gasoline. See engine manual for recommendations.
5. Check crankcase oil level and add proper oil if necessary.
6. Inflate tires to proper pressure. Check fluid levels.
7. Start the engine and let it run slowly. DO NOT run at high speed immediately after starting. Be sure to run engine only outdoors or in well ventilated area.

GENERAL

WARNING

To avoid serious injury, perform maintenance on the rider or mower only when the engine is stopped and the parking brake engaged. Always remove the ignition key, disconnect spark plug wire and fasten away from the plug before beginning the maintenance, to prevent accidental starting of the engine.

This section of the manual provides troubleshooting and repair instructions for the more common and easily corrected problems. For other problems, it is recommended that you contact your dealer. Locate the problem that best describes the trouble that you have encountered. Check the possible causes one at a time, in the order that they are listed.

TROUBLESHOOTING THE RIDER

Engine will not turnover or start.

1. Ground speed control lever not in neutral-start position. Shift into neutral.
2. PTO (electric clutch) switch in ON position. Place in OFF position.
3. Out of fuel. If engine is hot, allow it to cool, then refill the fuel tank.
4. Engine flooded.. Move throttle control out of CHOKE position .
5. Circuit breaker tripped. Wait one minute for automatic reset. Replace if defective (see your dealer).
6. Battery terminals require cleaning. See Normal Care section.
7. Battery discharged or dead. Recharge or replace.
8. Wiring loose or broken. Visually check wiring & replace broken or frayed wires. Tighten loose connections.
9. Solenoid or starter motor faulty. Repair or replace.
10. Safety interlock switch or module faulty. Replace if needed (see your dealer.)
11. Spark plug(s) faulty, fouled or incorrectly gapped. Clean and gap or replace. See engine manual.
12. Water in fuel. Drain fuel & refill with fresh fuel.
13. Old stale gas. Drain fuel & replace with fresh fuel.
14. Clutch/brake pedal not depressed.

Engine starts hard or runs poorly.

1. Fuel mixture too rich. Move the throttle control out of the CHOKE position. If problem persists, clean the air filter. See engine manual.

2. Carburetor adjusted incorrectly. See engine manual.
3. Spark plug(s) faulty, fouled, or incorrectly gapped. Clean and gap or replace. See engine manual.

Engine knocks.

1. Low oil level. Check/add oil as required.
2. Using wrong grade oil. See engine manual.

Excessive oil consumption.

1. Engine running too hot. Clean engine fins, blower screen and air cleaner.
2. Using wrong weight oil. See engine manual.
3. Too much oil in crankcase. Drain excessive oil.

Engine exhaust is black.

1. Dirty air filter. Clean air filter. See engine manual.
2. Choke not fully open. Move throttle control out of CHOKE position. If problem persists, check air filter and carburetor adjustments. See engine manual.

Engine runs, but rider will not drive.

1. Ground speed control lever in neutral. Shift in forward or reverse.
2. (Hydro models only) Transmission release lever in "push" position. Move into drive position.
3. Belt is broken. See Drive Belt Replacement.
4. Drive belt slips. See problem and cause below.
5. Brake is not fully released. See Brake Adjustment.

Rider drive belt slips.

1. Clutch is out of adjustment. See your dealer.
2. Pulleys or belt greasy or oily. Clean as required.
3. Belt stretched or worn. Replace with correct belt.
4. Idler pulley pivot bracket "frozen" in declutched position. Remove idler pulley, clean and lubricate.

Brake will not hold.

1. Brake is incorrectly adjusted. See Brake Adjustment.
2. Internal brake disc on transaxle worn. See your dealer.

Rider steers hard or handles poorly.

1. Steering linkage is loose. Check and tighten any loose connections. See Steering Gear Adjustment.
2. Improper tire inflation. Check and correct.
3. Spindle bearings dry. Grease spindles. See Lubricating the rider.

Troubleshooting & Repair

TROUBLESHOOTING THE MOWER

Mower will not raise.

1. Lift cable not properly attached or damaged. Attach or repair.

Mower cut is uneven.

1. Mower not leveled properly. See Mower Adjustment.
2. Rider tires not inflated equally or properly. See Normal Care.

Mower cut is rough looking.

1. Engine speed too slow. Set to full speed.
2. Ground speed too fast. Set ground speed control lever at a slower ground speed.
3. Blades dull and require sharpening. See Servicing the Mower Blades.
4. Mower drive belt slipping. Belt oily or worn. Clean or replace belt as necessary.
5. Check PTO (Electric Clutch) Adjustment. Clutch may need to be adjusted.
6. Blades not properly fastened to arbors. See Servicing the Mower Blades.

Engine stalls easily with mower engaged.

1. Engine speed too slow. Set for 3/4 to full throttle.
2. Ground speed too fast.
3. Carburetor not adjusted properly.
4. Cutting height set too low when mowing tall grass. Cut tall grass at maximum cutting height during first pass.
5. Discharge chute jamming with cut grass. Cut grass with discharge pointing toward previously cut area.

Excessive mower vibration.

1. Blade mounting screws are loose. Tighten to 50-70 ft.lbs. (67-95 N.m.).
2. Mower blade(s), arbors, or pulleys are bent. Check and replace as necessary.
3. Mower blade(s) out of balance. Remove, sharpen and balance blade(s). See Servicing the Mower Blade(s).
4. Belt installed incorrectly. See Belt Replacement.

Excessive belt breakage.

1. Bent or rough pulleys. Repair or replace.
2. Using incorrect belt. See your dealer.

Mower drive belt slips or fails to drive.

1. Idler pulley spring broken or not properly attached. See your dealer.
2. Mower drive belt broken. Replace.

CHECKING THE BATTERY

The voltmeter can be used to determine condition of battery. When engine is off, the voltmeter shows battery voltage, which should be 12 volts. When engine is running, the voltmeter shows voltage of charging circuit which normally is 13 to 14 volts.

A dead battery or one too weak to start the engine may not mean the battery needs to be replaced. It may, as an example, mean that the alternator is not charging the battery properly. If there is any doubt about the cause of the problem, see your dealer. If you need to replace the battery, follow the steps under Cleaning the Battery & Cables in the Normal Care Section.

CHARGING THE BATTERY

WARNING

Do not attempt to charge a frozen battery. Allow the battery to warm to 60° F (15.5° C) before placing on charge.

1. Be aware of all the safety precautions you should observe during the charging operation. If you are unfamiliar with the use of a battery charger and hydrometer, have the battery serviced by your dealer.
2. Add distilled water sufficient to cover the plates (fill to the proper level near the end of the charge). If the battery is extremely cold, allow it to warm before adding water because the water level will rise as it warms. Also, an extremely cold battery will not accept a normal charge until it becomes warm.
3. Always unplug or turn the charger off before attaching or removing the clamp connections.
4. Carefully attach the clamps to the battery in proper polarity (usually red to [+] positive and black to [-] negative).
5. While charging, periodically measure the temperature of the electrolyte. If the temperature exceeds 125° F (51.6° C), or if violent gassing or spewing of electrolyte occurs, the charging rate must be reduced or temporarily halted to prevent battery damage.

6. Charge the battery until fully charged (i.e. until the specific gravity of the electrolyte is 1.250 or higher and the electrolyte temperature is at least 60° F). The best method of making certain a battery is fully charged, but not over charged, is to measure the specific gravity of a cell once per hour. The battery is fully charged when the cells are gassing freely at low charging rate and less than 0.003 change in specific gravity occurs over a three hour period.

 **WARNING**

Keep open flames and sparks away from the battery; the gasses coming from it are highly explosive. Ventilate the battery well during charging.

 **WARNING**

For your personal safety, use extreme care when jump starting. Never expose battery to open flame or electric spark – battery action generates hydrogen gas which is flammable and explosive. Do not allow battery acid to contact skin, eyes, fabrics, or painted surfaces. Batteries contain a sulfuric acid solution which can cause serious personal injury or property damage.

JUMP STARTING WITH AUXILIARY (BOOSTER) BATTERY

The recommended procedure for starting a tractor with a dead battery is to remove the battery and charge it with a battery charger as describes in the Charging the Battery section. Jump starting is not recommended. However, if it must be done, follow these directions. Both booster and dis-charged batteries should be treated carefully when using jumper cables. Follow the steps below EXACTLY, being careful not to cause sparks. Refer to figure 23.

1. Both batteries must be of the same voltage (6, 12, etc.).
2. Position the vehicle with the booster battery adjacent to the vehicle with the discharged battery so that booster cables can be connected easily to the batteries in both vehicles. Make certain vehicles do not touch each other.
3. Wear safety glasses and shield eyes and face from batteries at all times. Be sure vent caps are tight. Place damp cloth over vent caps on both batteries.
4. Connect positive (+) cable to positive post of discharged battery (wired to starter or solenoid).
5. Connect the other end of same cable to same post marked positive (+) on booster battery.
6. Connect the second cable negative (-) to other post of booster battery.
7. Make final connection on engine block of stalled vehicle away from battery. Do not lean over batteries.
8. Start the engine of the vehicle with the booster battery. Wait a few minutes, then attempt to start the engine of the vehicle with the discharged battery.
9. If the vehicle does not start after cranking for thirty seconds, STOP PROCEDURE. More than thirty seconds seldom starts the engine unless some mechanical adjustment is made.
10. After starting, allow the engine to return to idle speed. Remove the cable connection at the engine or frame. Then remove the other end of the same cable from the booster battery.
11. Remove the other cable by disconnecting at the discharged battery first and then disconnect the opposite end from the booster battery.
12. Discard the damp cloths that were placed over the battery vent caps.

 **WARNING**

To avoid engine damage, do not disconnect battery while engine is running. Be sure terminal connections are tight before starting.

 **WARNING**

Any procedure other than the preceding could result in: (1) personal injury caused by electrolyte squirting out the battery vents, (2) personal injury or property damage due to battery explosion, (3) damage to the charging system of the booster vehicle or of the immobilized vehicle.

Do not attempt to jump start a vehicle having a frozen battery because the battery may rupture or explode. If a frozen battery is suspected, examine all fill vents on the battery. If ice can be seen or if the electrolyte fluid cannot be seen, do not attempt to start with jumper cables as long as the battery remains frozen.

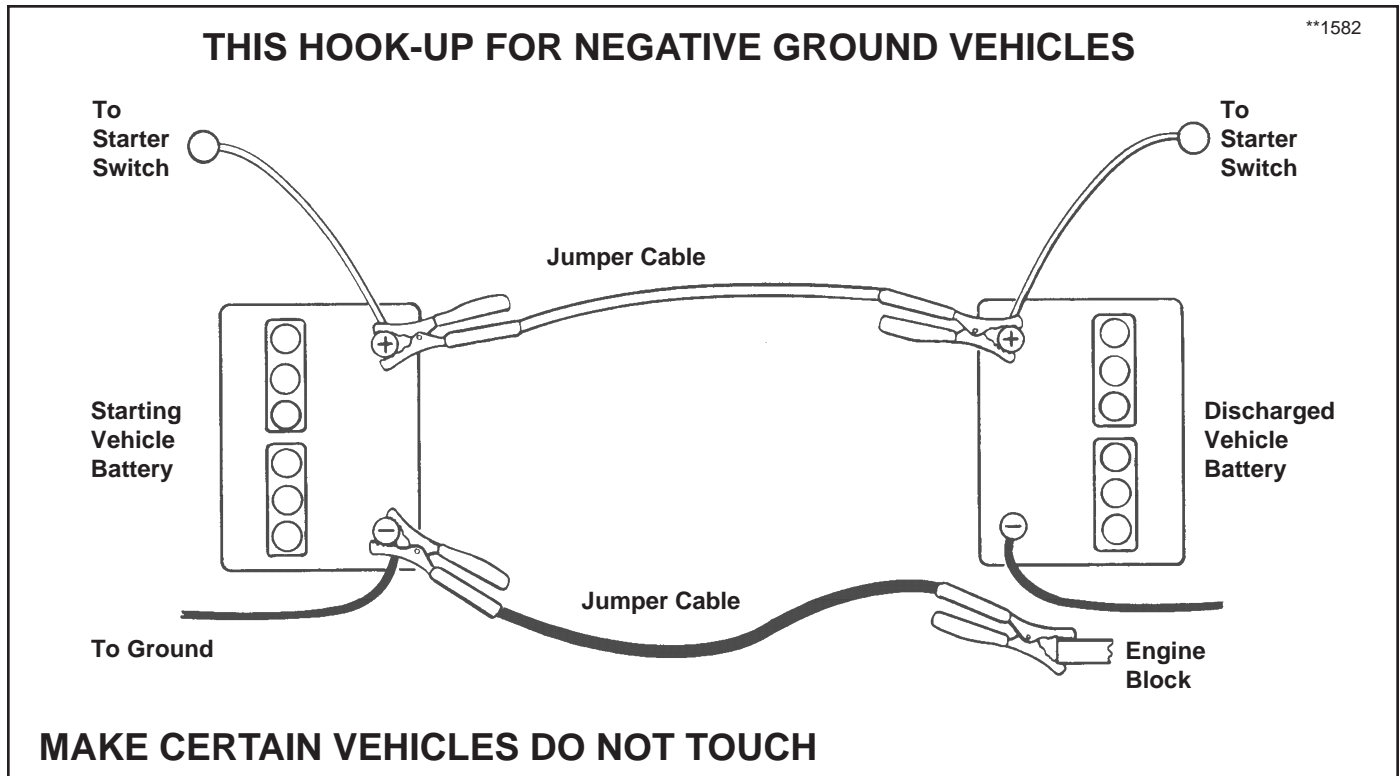

Figure 23. Battery Jump Starting Diagram

⚠ WARNING

To avoid serious injury, perform adjustments only with engine stopped, key removed and rider on level ground.

SEAT ADJUSTMENT

Use the lever to adjust the seat forward or rearward for best rider comfort.

BRAKE ADJUSTMENT

Brake Adjustment - Gear Models

1. Place the transmission in gear and release the parking brake.
2. Move the brake lever (B) forward. There should be a 1/8" gap between the lever (B) and the stop (C) as shown in figure 24.
3. To adjust clearance, turn nut (D) clockwise to decrease the gap or turn nut counterclockwise to increase the gap.
4. Set the parking brake. Loosen or tighten adjustment nut (E) to achieve a 2 9/16"–2 5/8" compressed spring length as shown in figure 24.

Brake Adjustment - Hydro Models

1. Release the parking brake.
2. Place a .025" feeler gauge (A, figure 25) between the two outer brake stators (refer to inset illustration). The gap should be between .025"–.030". To adjust:
 - a. Remove cotter pin from castellated nut if present.
 - b. To **decrease** gap, hold feeler gauge in gap and turn nut (B) clockwise until resistance is felt on the feeler gauge. To **increase** gap, turn nut (B) counter-clockwise and recheck gap.
 - c. If cotter pin was removed, back off nut (counter-clockwise) until the nearest slot is aligned with hole in threads. Replace cotter pin.
3. Set the parking brake. Loosen or tighten adjustment nut (C) to achieve a 2 11/16"–2 13/32" compressed spring length as shown in figure 25.

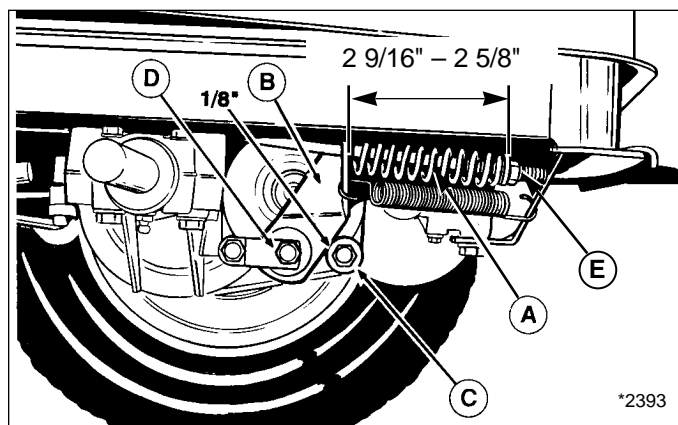

Figure 24. Brake Adjustment (Gear Model)

- A. Compressed Spring
- B. Brake Lever
- C. Stop
- D. Nut
- E. Adjustment Nut

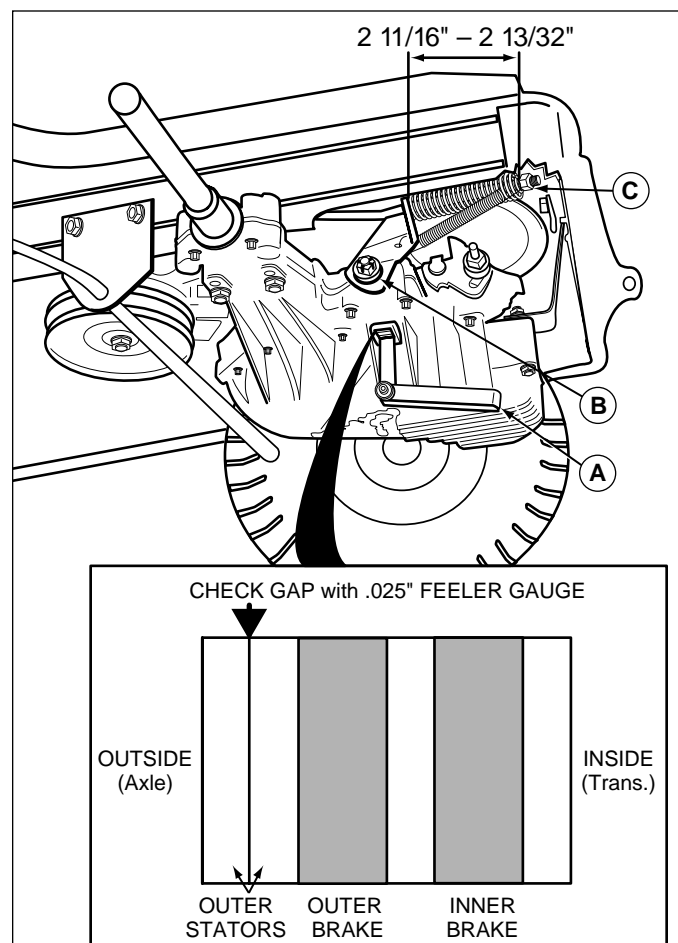

Figure 25. Brake Adjustment (Hydro Model)

- A. Feeler Gauge
- B. Nut
- C. Adjustment Nut

Adjustments

STEERING GEAR ADJUSTMENT

If there is excessive slack in the steering system, the steering gear can be reindexed to the steering shaft.

1. See figure 30. Loosen the two capscrews and push bracket so that gear teeth are closely meshed.
2. Tighten nuts after adjustment.

STEERING WHEEL ADJUSTMENT

Your unit is equipped with a dual position steering shaft to allow for steering wheel adjustment for rider comfort.

1. Pull down on the rubber boot to expose the two holes in the steering shaft (figure 32).
2. Use a suitable drift to remove the roll pin at the base of the steering wheel.
3. Align the hole in the steering wheel with the appropriate steering shaft hole and install the roll pin.

NOTE: Steering wheel is factory installed with the roll pin in the bottom hole.

MOWER ADJUSTMENTS

If the cut is uneven, the mower may need leveling. Unequal or improper tire pressure may also cause an uneven cut. Make sure tire pressure is correct as specified in Checking Tire Pressure. To achieve proper mower levelling, perform Side-To-Side Leveling, Front-To-Back Leveling and Transport Height Adjustment procedures, in order, as follows.

Side-To-Side Leveling

1. With the mower installed, place the rider on a smooth, level surface such as a concrete floor. Turn the front wheels straight forward.
2. Check for bent blades and replace if necessary.
3. Loosen nut (C, figure 34) so trailing arms are loose. Mower must be resting on rollers with no weight on trailing arms.
4. Use the Dial-A-Cut™ Control (E, figure 32) and place mower in mid-cut position by aligning front edge of mower lift lever (A) with number 2 or 3 on quadrant scale. Make sure mower lift lever is in down position.
5. Make sure rear rollers (C, figure 31) are on the ground. If not, refer to Transport Height Adjustment.

NOTE: If rollers do not rest on the ground and it is necessary to perform transport height adjustment, it is necessary to perform transport height adjustment again after all leveling procedures are completed.

5. Position blade(s) side-to-side and measure distance from outside tip of blade(s) to ground. Measurement should be equal (within 1/8").

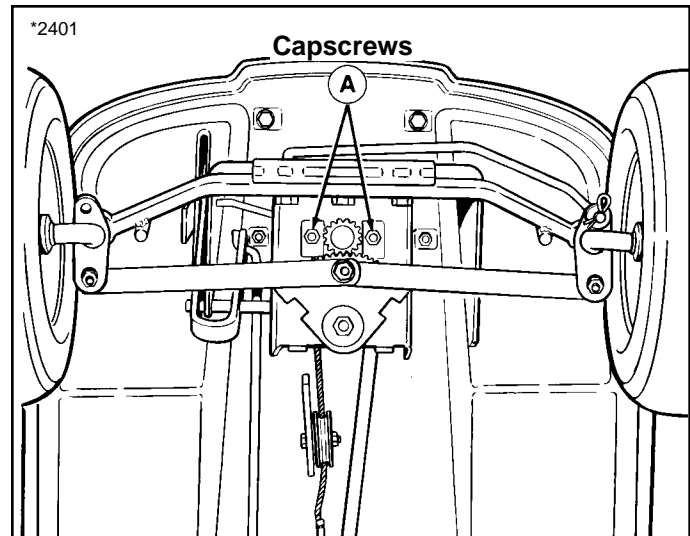

Figure 30. Steering Gear Adjustment

⚠ WARNING

Before levelling mower, shut off PTO and engine. Allow all moving parts to stop. Remove ignition key, then disconnect the spark plug wire and fasten it away from the spark plug.

⚠ WARNING

Mower blades are sharp. Turn the mower drive belt to rotate blades into position or wear protective gloves to protect against injury.

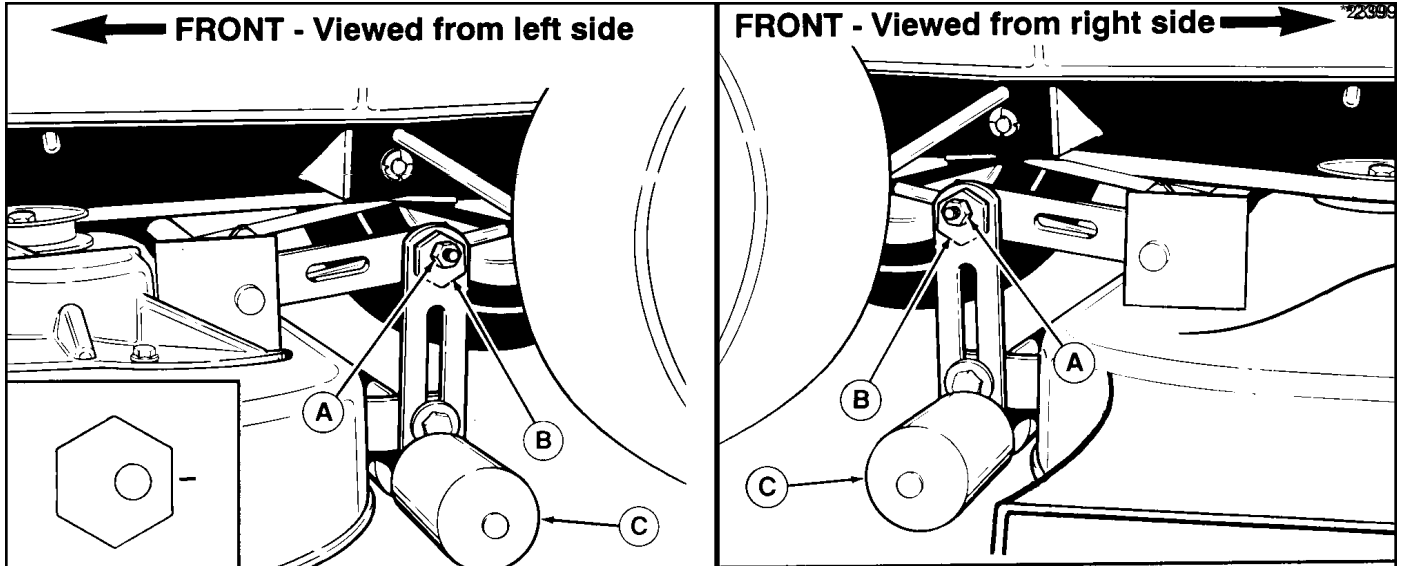

Figure 31. Leveling The Mower Side-to-Side

- A. Nut
- B. Eccentric Nut
- C. Rear Rollers

6. See figure 31. On left side of mower, make sure eccentric nut is in correct position as shown. Loosen outside nut (A) and rotate eccentric nut (B) so that flat side with hole closest to it is towards the rear. Tighten outside nut (A) while holding eccentric nut (B).
7. On right side of mower, loosen outside nut (A). Turn eccentric nut (B) counterclockwise to raise side of mower, or clockwise to lower right hand side of mower.

NOTE: Do not turn eccentric nut more than 1/4 turn in either direction. When adjusted beyond 1/4 turn, nut will move mower in opposite direction than when starting adjustment.

8. When adjustment is correct, hold eccentric nut (B) and tighten nut (A) to 30 ft. lbs. Check measurement on both sides of mower.

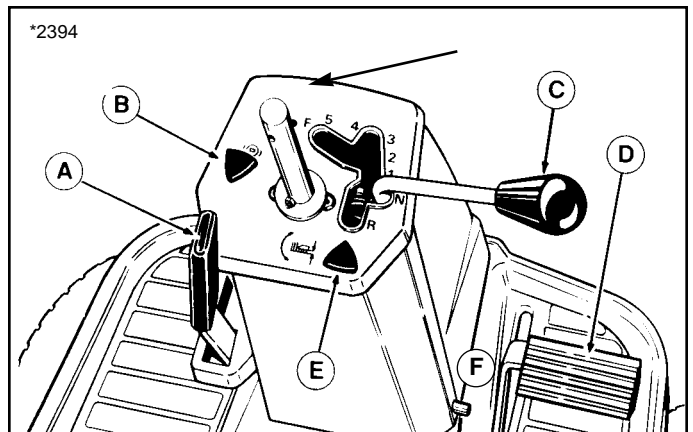
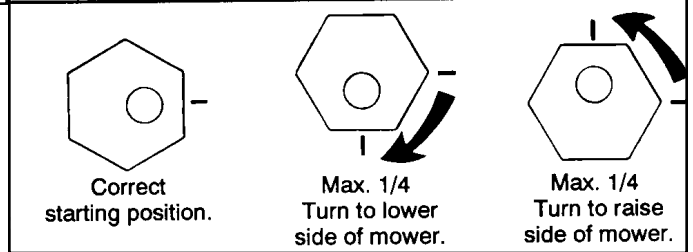

Figure 32. Dash Controls (shown with steering wheel removed)

- A. Mower Lift Lever
- B. Parking Brake Knob
- C. Ground Speed Lever
- D. Clutch/Brake Pedal
- E. Dial-A-Cut™ Control
- F. Steering Shaft

Adjustments

Front-To-Back Levelling

1. Make sure mower is level side-to-side and that rear rollers are on the ground.
2. Position blade(s) front-to-back. Measure the distance from the ground to front tip of blade(s), and from ground to rear tip of blade(s).

On 30" mower, the front tip should be level to 1/8" (3 mm) higher than rear tip.

On 34" mower, the front tips should be 1/4" (6 mm) higher than the rear tips.

3. See figure 33. Loosen jam nut (E). To lower rear of mower deck, loosen nut (B) which will lengthen leveling rod (D). To raise rear of deck, shorten leveling rod (D). When proper measurement is obtained, tighten nut (A) against bracket, then tighten jam nut (E) against nut (A).

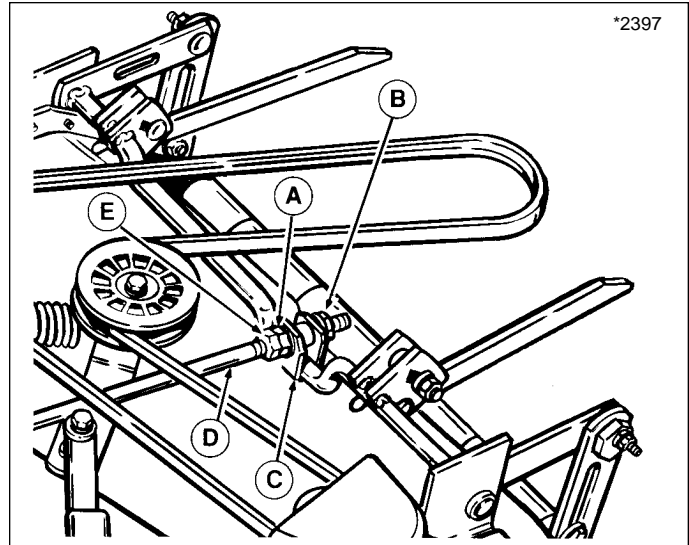

Figure 33. Front-To-Back Levelling

- | | |
|-------------------|------------------|
| A. Adjustment Nut | D. Levelling Rod |
| B. Rear Nut | E. Jam Nut |
| C. Bracket | |

Transport Height Adjustment

Transport height should be adjusted so that rear mower rollers are 1/8" - 1/4" (3-6 mm) above ground when mower lift lever is in transport position. To adjust, perform both mower leveling procedures first, then do the following procedure.

See figure 34.

1. Park rider on a flat level surface.
2. Adjust Dial-A-Cut™ control so that front edge of mower lift lever is aligned with 2-3/4" mark (34" mower) or at 3" mark (30" mower) on the quadrant scale.
3. Loosen nut (C) and position spacer (A) against rear trailing arms (D). Position both the left and right side spacers against trailing arms.
4. Tighten nut (C) securely.
5. Place mower lift lever in transport position. Rear mower rollers should be 1/8" - 1/4" off ground. If not, repeat steps 2 - 4.

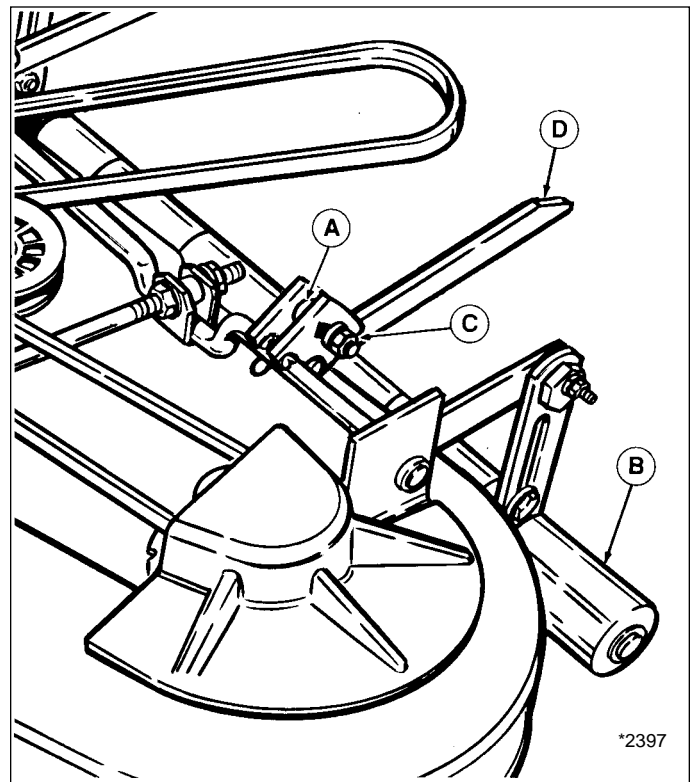

Figure 34. Transport Height Adjustment

- | | |
|-----------------------|-----------------------|
| A. Spacers | C. Nut |
| B. Rear Mower Rollers | D. Rear Trailing Arms |

Blade Brake Adjustment

Mower blades and mower drive belt should come to a complete stop within five seconds after electric PTO switch is turned off.

1. With rider in neutral, PTO disengaged and operator in seat, start the rider engine.
2. Look over the left-hand footrest at the mower drive belt. Engage the PTO and wait several seconds. Disengage the PTO and check the amount of time it takes for the mower drive belt to stop.
3. If mower drive belt does not stop within five seconds, see your dealer.

CAUTION

To avoid damaging belts, do not pry belts over pulleys.

RIDER DRIVE BELT

Replacement of the riderdrive belt requires removal of the transmission and carrier frame. Should the drive belt ever fail, contact your dealer for replacement.

MOWER BELT - 30"

See figure 35.

1. Mower does not need to be removed to install a new belt. However, for easier access, mower can be removed following steps in "Mower Removal and Installation."
2. If mower is not removed, place mower in lowest cutting position. Pull idler pulley arm (A) towards you to relieve belt tension. Remove belt from idler pulley (B) and center arbor pulley (C).
3. Remove belt from front idler pulley (D) and PTO pulley (E).
4. Replace old belt with new belt. Make sure V-side of belt runs in all pulley grooves except for idler pulley (B). Check belt pattern as shown.
5. Install mower if it was removed, and install belt on PTO pulley (E).

MOWER BELT - 34"

1. Mower does not need to be removed to install a new belt. However, for easier access, mower can be removed following steps in "Mower Removal and Installation."
2. If mower is not removed, place mower in lowest cutting position. Push idler pulley arm (A, figure 36) away from you to relieve belt tension. Remove belt from idler pulley (B) and PTO pulley (C).
3. Remove the three capscrews (D, figure 36) securing the left-hand arbor cover.
4. Remove old belt from arbor pulleys and replace with new belt. Make sure V-side of belt runs in all arbor pulley grooves and flat side of belt runs against idler pulley. See figure 37 for belt pattern
5. Install mower if it was removed, and install belt to PTO pulley (C, figure 36). Push idler arm and install belt around idler pulley.

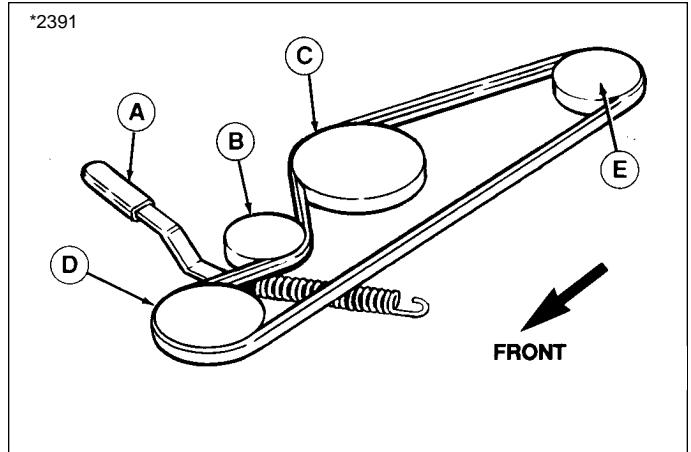

Figure 35. Belt Pattern - 30" Mower

- | | |
|------------------------|-----------------------|
| A. Idler Pulley Arm | D. Front Idler Pulley |
| B. Idler Pulley | E. PTO Pulley |
| C. Center Arbor Pulley | (Electric Clutch) |

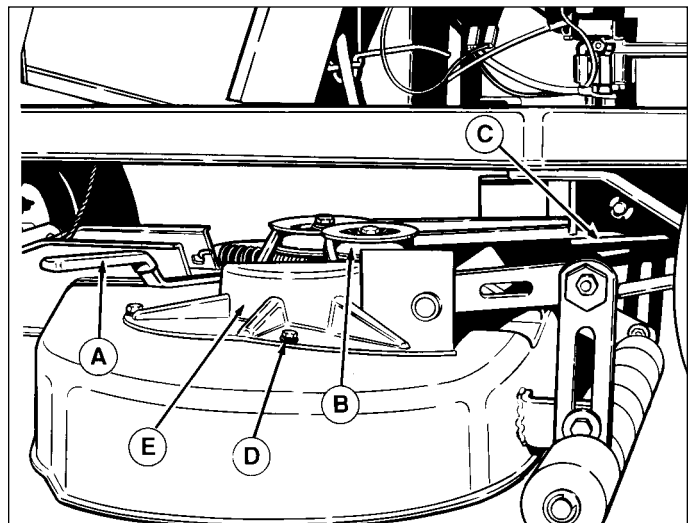

Figure 36. Mower Belt Replacement - 34"

- | | |
|---------------------|----------------|
| A. Idler Pulley Arm | D. Capscrews |
| B. Idler Pulley | E. Arbor Cover |
| C. PTO Pulley | |

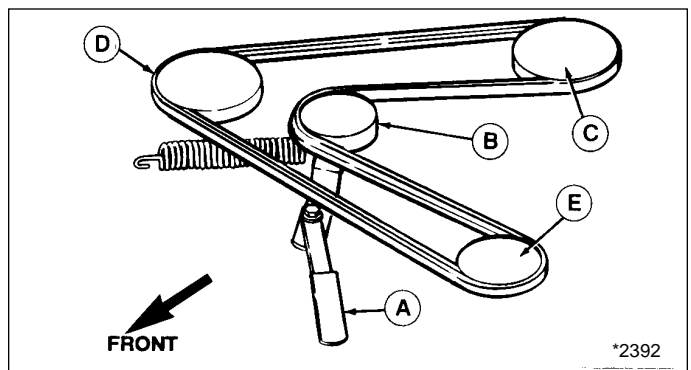

Figure 37. Belt Pattern - 34" Mower

- | | |
|---------------------|-----------------------|
| A. Idler Arm Pulley | D. Right Arbor Pulley |
| B. Idler Pulley | E. Left Arbor Pulley |
| C. PTO Pulley | |

Specifications

NOTE: Specifications are correct at time of printing and are subject to change without notice.

ENGINE

11 HP I/C — Briggs & Stratton

Horsepower	10.5 HP @ 3600 rpm
Cylinders	1
Bore	3.44 In. (87 mm)
Stroke	3.06 In. (77 mm)
Displacement	28.4 Cu. In. (465 cc)
Construction	Cast Iron Sleeves, Aluminum Crankcase
Electrical System	12 Volt, 3 Amp D.C. Unregulated Battery: 200 Cold Cranking Amps, 23 min. Reserve Capacity
Ignition	Electronic, Solid State, Maintenance Free
Air Cleaner	Reusable Oil Foam Element
Lubrication	Splash Lube
Oil Capacity	3 Pints (1.42 L)
Fuel Capacity	2 Gal. (7.57 L)
Muffler	Quiet Compact, Low Back Pressure

13 HP Diamond OHV — Briggs & Stratton

Horsepower	13 HP @ 3600 rpm
Cylinders	1
Bore	3.44 In. (87 mm)
Stroke	3.06 In. (77 mm)
Displacement	28.4 Cu. In. (465 cc)
Construction	Cast Iron Sleeves, Aluminum Crankcase
Electrical System	12 Volt, 3 Amp D.C. Unregulated Battery: 200 Cold Cranking Amps, 23 min. Reserve Capacity
Ignition	Electronic, Solid State, Maintenance Free
Air Cleaner	Pre-Cleaned Air to Paper Filter
Lubrication	Splash Lube
Oil Capacity	2 Pints (1.42 L)
Fuel Capacity	2 Gal. (7.57 L)
Muffler	Quiet Compact, Low Back Pressure

14 HP Command™ — Kohler

Horsepower	14 HP @ 3600 rpm
Cylinders	1
Bore	3.43 In. (87 mm)
Stroke	2.64 In. (67 mm)
Displacement	24.3 Cu. In. (398 cc)
Construction	Overhead Valve, Cast Iron Sleeves, Aluminum Crankcase
Electrical System	12 Volt, 15 Amp Alternator Regulated Battery: 200 Cold Cranking Amps
Ignition	High Energy Electronic Ignition
Air Cleaner	Ducted Paper Cartridge and Foam Pre-cleaner
Lubrication	Full Pressure Lube with Oil Filter
Oil Capacity	4 Pints (1.9 L)
Fuel Capacity	2 Gal. (7.57 L)
Muffler	Quiet Compact, Low Back Pressure

TRANSMISSION

Gear Models

Type	Spur Gear
Material	Gear: Powered Metal Shaft: Hardened Bearings: Needle Roller and Bushings
Lubrication	Bentonite Grease. Transmission is a sealed unit.
Differential	Bevel Gear Type
Gear Range	Five Forward, One Reverse
Ground Speeds	1st: 1.2 MPH (1.9 km/h) 2nd: 2.4 MPH (3.9 km/h) 3rd: 3.5 MPH (5.6 km/h) 4th: 4.4 MPH (7.1 km/h) 5th: 5.6 MPH (9.0 km/h) Reverse: 2.0 MPH (3.2 km/h)

Hydro Models

Type	Hydrostatic
Lubrication	Transmission is a Sealed Unit
Differential	Bevel Gear Type
Ground Speeds	Infinite Forward: 0-5.2 MPH (0-8.4 km/h) Reverse: 0-2.3 MPH (0-3.7 km/h)

CONTROLS

Steering	Full Circle Steering Wheel System Gear and Sector
Clutch/Brake Pedal	Location Right Front Combination Clutch/Brake Pedal
Parking Brake	Dash Lock Finger Release
Ground Speed Shift Lever	Dash Mounted
Throttle Control	Combination Speed & Choke Control on right side of seat deck
Key Switch	Starter and Magneto ON/OFF Switch located on left side of seat deck
Mower Drive	Electric Clutch PTO Switch located on right side of seat deck
Mower Cutting Height	Infinite Height Control on Steering Column

CHASSIS

Frame	Heavy Gauge, Deep Drawn Steel
Front Axle	Self-Leveling Quick Hitch
Seat Deck	Lightweight Polymer Alloy
Seat	Molded Type with Foam Cushion and Spring Construction
Front Wheels	Tire Size 13 x 5.00-6 Pneumatic Inflation Pressure 10 -12 psi (68 - 82 kPa)
Rear Wheels	Tire Size 16 x 6.50-8 Pneumatic Inflation Pressure 10 -12 psi (82 - 103 kPa)
Accessibility Seat	Seat Deck Tips Forward Type Bucket, High Back, Adjustable w/ Spring Suspension, Fore and Aft Adjustable
Fuel Tank	Material: Non-Corrosive Polyethylene Alloy Capacity: 2 Gallons (7.5 L)
Turning Radius	Inside Rear Tire 12 In. (30.2 cm)

DIMENSIONS

Rider

Overall Length	61 In. (155 cm)
Overall Width	
- w/30 mower	38.5 In. (97.8 cm)
- w/34 mower	45.5 In. (115.6 cm)
- at rear wheels	33 In. (83.8 cm)
Height at	
- steering wheel	41 In. (104.1 cm)
- seat back	35 In. (88.9 cm)
- engine cover	28 In. (71.1 cm)
Wheel Base	43 In. (109.2 cm)
Weight (approx.)	
- 8.5 HP w/30"mower	Net: 405 lbs. (183 kg) Shipping: 530 lbs. (241 kg)
- 12 HP w/30"mower	Net: 405 lbs. (183 kg) Shipping: 530 lbs. (241 kg)
- 12 HP w/34"mower	Net: 405 lbs. (183 kg) Shipping: 530 lbs. (241 kg)
- 13 HP w/34"mower	Net: 405 lbs. (183 kg) Shipping: 530 lbs. (241 kg)

Mower

Type:	30" Single Blade 34" Dual Blade
Height of Cut	1.0 - 3.75 In. (2.45- 9.53 cm)
Cutting Positions	Infinite
Level Adjustments	Side-to-Side & Front-to-Back
Spindles	Sealed Ball Bearings w/Lube Fitting
Blade Mounting	Center Bolt With Spring Positioning
Discharge Deflector Mounting	Hinged with Spring Positioning At Front Axle - Quick Hitch with Auto-Leveler™

International Symbols



Fast



Slow



Operator Present
Switch (Seat)



PTO Engaged



Lights



Oil Pressure



Forward



Reverse



Parking Brake



Choke



Engine Running

Parts & Accessories

USE ONLY GENUINE FACTORY REPLACEMENT PARTS

Available Through Your Local Authorized Dealer.

COMMON REPLACEMENT PARTS

Listed below are the more common replacement parts. Only genuine factory replacement parts will assure optimum performance and safety. Do not attempt repairs or maintenance unless proper procedures and safety precautions are followed. For assistance in any area, see your dealer.

QTY.	DESCRIPTION	PART NO.
	Mower Blades	
1	- 30"	1664019
2	- 34" Large Blade (R.H.)	1706738
2	- 34" Small Blade (L.H.)	1706737
	Mower Belts	
1	- 30" Mower Drive	1651201
1	- 34" Mower Drive	108209
	Rider Drive Belt	
1	- Gear	1676460
1	- Hydro	1709323
2	Retaining Pin - Mower Lift	1960074
1	Key, Ignition	1704348
1	Interlock Switch, Seat	1704379
1	Battery	1685215
1	Solenoid	1685290

OPTIONAL ACCESSORIES

See your dealer to purchase these items.

Clean Sweep Twin Catcher	Dethatcher
Front Counterweight	Dump Cart

MAINTENANCE ITEMS

- **Simplicity Engine Oils**
Case of 12 qts. (Your dealer has 1 qt. cans)
-SAE 5W-30 SF/CD (Cold Weather 30° & under) 1685576
-SAE 30 SG/CC (Warm weather 32° & up) 1685659
- **Touch-Up Paint**
Deep Orange Spray Paint, 13 oz. Can 1685611
Deep Orange Spray Paint (Case of 12 -13 oz. Cans) 1685614
Deep Orange Paint, 1 qt. 1685612
White Spray Paint, 13 oz. Can 103049
Red Spray Paint, 13 oz. Can 1685722
Metallic Gray Spray Paint, 13 oz. Can 1685718
- **Touch-Up Daubers**
Deep Orange 1/2 oz. w/Brush Cap 1685615
- **Grease Gun Kit** w/8 oz. Grease Tube 1685510
Replacement 8 oz. Grease Tube for above 103077
- **Tire Sealant**-Stops Tire Leaks. Prevents Flats.
11 oz. Tube 1685523
- **Gas Can**-No Tip Design. Durable Polyethylene.
1 gallon 1685587
2-1/2 gallon 1685555
5-1/4 gallon 1685556
- **Cleaner, Polish, Sealant & Protectant**
8 oz. Bottle 1685696
- **Degreaser/Degreaser**
32 oz. Bottle w/Trigger Spray 1685619
1 gallon 1685621

Technical Manuals

Additional Technical Literature Available

Operators Manuals

Additional copies of this manual are available, (and as part of our product support commitment, we maintain a stock of printed operators manuals going back many years!)

Parts Manuals

Fully illustrated parts manuals are also available — these manuals show all of the product's components in exploded views ("3D" illustrations which show the relationship of the parts and how they go together), as well as giving the replacement part numbers and quantities used. Important assembly notes and special torque values are included in these manuals.

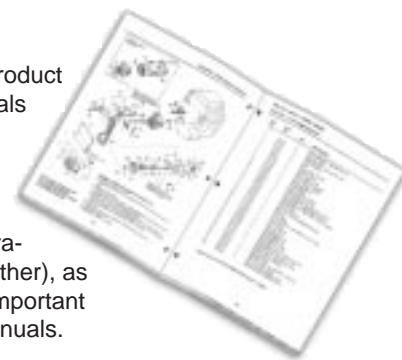

For the applicable manuals currently available for your model, contact our Customer Publications Department at 414-284-8519.

Have the information listed in the box at the right available when phoning in your request.

Please allow 3 to 4 weeks for delivery.



Model: _____
Mfg. No.: _____
Your Name: _____
Address: _____
City, State, Zip: _____
Visa/Mastercard No.: _____
Card Expiration Date: _____