

# SCAG®

## ZERO TURN RADIUS COMMERCIAL MOWERS TECHNICAL MANUAL

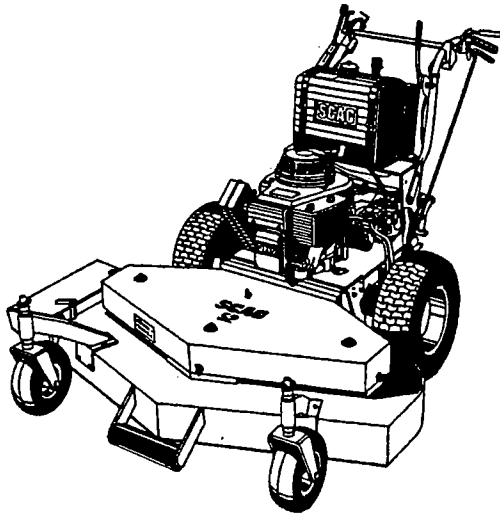

### MODELS

SWZ36-14KA  
SWZ36-14KH  
SWZ48-14KA  
SWZ48-14KH

SWZ-14KA  
SWZ-14KH  
SWZ-18KH  
SWZ-20KHE

SWM-52  
SWM-61  
SWM-72

PATENT NO. 4,885,903

**TABLE OF CONTENTS**

<b>SUBJECT</b>	<b>PAGE</b>
Safety Instructions	
Before Operating _____	2
While Operating _____	2-3
While Maintaining and Storing _____	3
Hydraulic Safety _____	3
Assembly Instructions _____	4-6
Adjustments _____	6-10
Initial Run-in _____	11
Operating Instructions _____	11
Maintenance _____	12-13
Lubrication/Maintenance Chart _____	13
36" Cutter Deck _____	14-15
48", 52", 61" & 72" Cutter Deck _____	16-17
Engine Deck _____	18-20
Replacement Decals _____	21
Handle Assembly _____	22-24
Wiring Diagram Electric Start _____	25
Wiring Diagram Manual Start _____	26
Warranty _____	27



## **SAFETY INSTRUCTIONS**

Your mower is only as safe as the operator! As with any type of power equipment, carelessness or error on the part of the operator may result in serious bodily injury or property damage. In addition, improper maintenance of the machine can also result in injury or property damage. To reduce the potential for injury or property damage, please read and follow these instructions on safe operation and be certain that anyone using this mower fully understands and complies with the following instructions.

### **BEFORE OPERATING**

1. Read and understand the contents of this Technical Manual before operating the machine. Become familiar with all controls and know how to stop quickly. A free replacement manual is available by sending complete Model and Serial Number to:  
Scag Power Equipment, Inc.  
1000 Metalcraft Drive  
Mayville, WI 53050
2. Do not allow children to operate the machine. Do not allow adults to operate the machine without proper instruction.
3. Before attempting to start engine, move speed adjustment lever to neutral position, move blade clutch lever into STOP position and move neutral latches to NEUTRAL LOCK.
4. Remove all debris or other objects that might be picked up and thrown by the cutter blades. Keep all bystanders away from the mowing area.
5. Keep all shields, safety devices, and decals in place. If a shield, safety device or decal is defective or damaged, repair or replace it before operating. Also, tighten all loose nuts, bolts and screws to assure machine is in safe operating condition.
6. Always wear long pants and substantial shoes. Do not operate machine while wearing sandals, tennis shoes, sneakers or shorts. Also, do not wear loose fitting clothing which could get caught in moving parts. Wearing safety glasses and safety shoes is advisable and required by some local ordinances and insurance regulations.
7. Fill fuel tank with gasoline before starting the engine. Avoid spilling gasoline. Since gasoline is flammable, handle it carefully.
  - A. Use an approved gasoline container.
  - B. Do not fill tank while engine is hot or running.
  - C. Do not smoke while handling gasoline.
  - D. Fill fuel tank outdoors and up to about one inch (25 mm) below the bottom of the filler neck.
  - E. Wipe up any spilled gasoline and dispose of the siping material properly.

### **WHILE OPERATING**

8. To start engine, move speed control lever to neutral position, move blade clutch lever into STOP position and neutral latches into NEUTRAL LOCK position.
9. Do not run the engine in a confined area without adequate ventilation. Exhaust fumes are hazardous and could possibly be deadly.
10. Using the machine demands attention. To prevent loss of control:
  - A. Mow only in daylight or when there is good artificial light.
  - B. Watch for holes or other hidden hazards.
  - C. Do not drive close to a drop-off, ditch, creek or other hazard.
  - D. Reduce speed when making sharp turns and when turning on hillsides.
  - E. Always be sure of your footing. Keep a firm hold on the handle and walk--never run.
  - F. Do not operate where conditions are slippery.
11. The discharge chute must always be installed and in the down position on the side discharge cutting unit except when optional grass catcher or mulching plate is completely installed. If the cutting unit discharge should plug, shut engine off and wait for all movement to stop before removing obstruction.
12. Disengage the blades and wait for them to stop before crossing gravel drives, walks or roads.
13. Shut the engine off and wait until the blades come to a complete stop before removing the grass catcher container.
14. Never raise the cutting unit while the blades are rotating.
15. If the cutting blades should strike a solid object or the equipment should start to vibrate abnormally, stop the engine, disconnect the spark plug wire, and check immediately for the cause. Vibration is generally a warning of trouble. Check the cutting unit and traction unit for damaged or defective parts. Repair any damage before starting the engine and operating the cutter unit. Be sure blades are in good condition and blade bolts are tight.
16. Always park the mower and/or start the engine on a level surface. If this is not possible, block the wheels to prevent the mower from moving when you are not in the operator's position.
17. Cut grass slopes carefully. Do not start, stop or turn suddenly. Mow across the face of slopes; never up or down. Do not mow excessively steep slopes.

## **SAFETY INSTRUCTIONS CONT'D**

18. Do not touch engine or muffler while engine is running or soon after it is stopped. These areas could be hot enough to cause a burn.
19. Before leaving the operator's position or leaving mower unattended, move speed adjustment lever into NEUTRAL position, place neutral latches in NEUTRAL LOCK position, move cutter blade engagement lever to STOP and shut OFF engine.
20. Do not pass or stand on the grass discharge side of any mower with the engine running. Stop operation when another person approaches.
30. Keep the mower and fuel container in locked storage to prevent children from playing and tampering with them.
31. Perform only those maintenance instructions described in this manual. If major repairs are ever needed or assistance is desired, contact an Authorized Scag Dealer. To ensure optimum performance and safety, always purchase genuine SCAG replacement parts and accessories. NEVER USE "WILL-FIT" replacement parts and accessories made by other manufacturers. Using unapproved replacement parts and accessories may void the warranty.

### **MAINTENANCE AND STORAGE**

21. Disconnect high tension wire from spark plug to prevent accidental starting of the engine when servicing, adjusting or storing the machine.
22. If mower must be tipped to perform maintenance or adjustment, remove battery, drain gasoline from fuel tank and oil from crankcase.
23. To reduce potential fire hazard, keep the engine free of excessive grease, grass, leaves and accumulations of dirt.
24. Be sure machine is in safe operating condition by keeping nuts, bolts, and screws tight. Check the blade mounting bolts and nuts frequently to be sure they are tightened.
25. If the engine must be running to perform a maintenance adjustment, keep hands, feet, clothing and other parts of the body away from the cutting unit blades and other moving parts.
26. Do not overspeed the engine by changing governor settings. To be sure of safety and accuracy, have an authorized dealer check maximum engine speed.
27. Engine must be shut off before checking oil or adding oil to the crankcase.
28. Allow engine to cool before storing mower in any enclosure such as a garage or storage shed. Make sure the mower fuel tank is empty if machine is to be stored in excess of 30 days. Do not store mower near any open flame or where gasoline fumes may be ignited by a spark.
29. Always store gasoline in a safety-approved, red container.
32. Be careful when servicing the battery as it contains acid, which is corrosive and could cause burns to skin and clothing.
33. Batteries release explosive gases when being charged or discharged. KEEP away from any source of sparks and/or flame.

### **HYDRAULIC SAFETY**

The (2) two hose lines connecting each pump to each motor are pressurized hose lines. Whenever disconnecting these hose lines, the pressure must be relieved first. To relieve pressure, open up the dump valve on the pump and slowly crack open the hose fitting approximately 2 to 3 turns. If hydraulic fluid bubbles through cracked fitting and there is still pressure inside the line, let pressure relieve itself through cracked open fitting.

**⚠ WARNING:** Hydraulic fluid escaping under pressure may have sufficient force to penetrate skin and cause serious injury. If foreign fluid is injected into the skin, it must be surgically removed within a few hours by a doctor familiar with this form of injury or gangrene may result.

**⚠ WARNING:** Keep body and hands away from pin holes or nozzles that eject hydraulic fluid under high pressure. Use paper or cardboard and not hands to search for leaks.

**⚠ WARNING:** Make sure all hydraulic fluid connections are tight and all hydraulic hoses and lines are in good condition before applying pressure to the system.

## ASSEMBLY INSTRUCTIONS

### ELECTRIC START UNITS ONLY!

Before proceeding with assembly, prep the battery. Remove battery from unit and put on a flat surface. Fill each cell with electrolyte until the top of the plates are covered, charge the battery at 3 to 4 amps for 4 hours (this insures a good initial charge), check and add electrolyte as needed to bring the fluid level to the bottom of the split ring, and then wash and dry off the battery.

**NOTE:** Once the above fill and charge procedure has been completed only distilled water should be added to the battery cells.

To install battery on to the mower follow assembly instructions supplied in the battery kit.

**WARNING:** Severe chemical burns can result from improper handling of battery electrolyte. Use proper eye, skin and clothing protection to prevent contact with eyes, skin and clothing.

External contact: Flush with water.

Internal contact: Drink large quantities of water, followed with milk of magnesia, beaten egg or vegetable oil.

**CALL A PHYSICIAN IMMEDIATELY!**

**IMPORTANT -** In case of internal contact DO NOT give fluids that would induce vomiting.

Eye contact: Flush with water for at least 15 minutes and GET MEDICAL ATTENTION IMMEDIATELY!

**WARNING:** Explosive gases are vented from a battery when being charged or discharged which could explode if exposed to a flame or spark.

### SET-UP ALL UNITS

1. Lay out hardware according to the "Where Used" list in the List of Hardware Package Contents.
2. Install handle assembly to handle mounting frame using (4) four 3/8-16 x 1" bolts, flat washers, and elastic stop nuts. Three different handle heights can be obtained using one of the three slotted holes in the handle mounting frame.
3. Route the throttle control below the handle mounting frame and up the right side of handle. Secure to handle with (1) one 1/4-20 x 2" hex head bolt and elastic stop nut. Secure cable about half way down the handle using a cable tie.

**NOTE:** Check that the throttle cable moves the carburetor controls through their full range including choke. If not, adjust as required.

4. Route the safety interlock wires up the left handle tube and attach the connector to the switch as shown. Be certain that the connector does not hit the safety lever stop tab. If it does, rotate the switch to the position shown (See figure 1). Secure wires with cable ties.

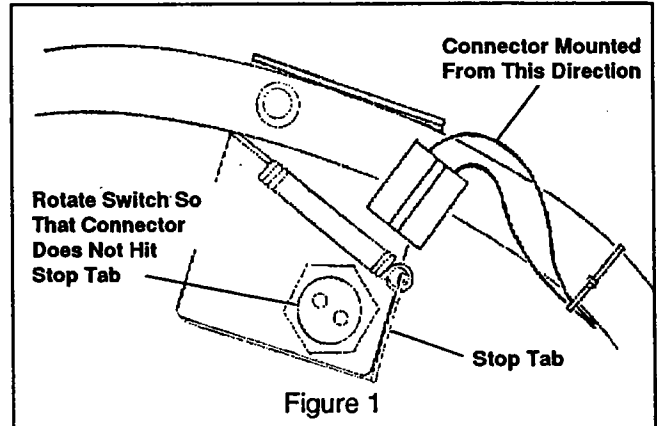

5. Installing steering control rods. Thread rod into swivel joint. Adjust length of rod so that with the handle neutral latch in the neutral position, (See figure 3) the swivel joint is centered in the slot on the bellcrank (See figure 2). This is easily confirmed by wiggling the handle control lever up and down. The bellcrank should not move if the swivel joint is centered in the slot. **This is a very, very important adjustment for safe operation!**

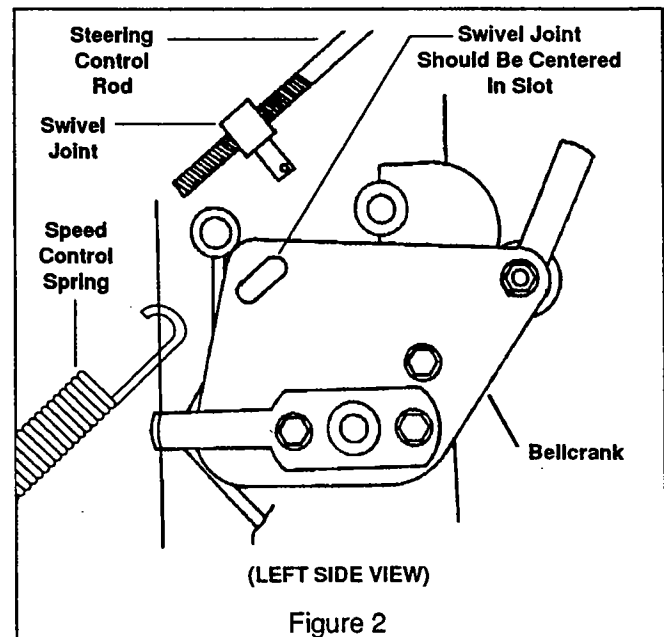

## ASSEMBLY INSTRUCTIONS CONT'D

6. Remove swivel joint from slot (making sure swivel joint does not turn on rod). Connect speed control spring (See figure 2). Reposition swivel joint into slot and secure with hair pin.

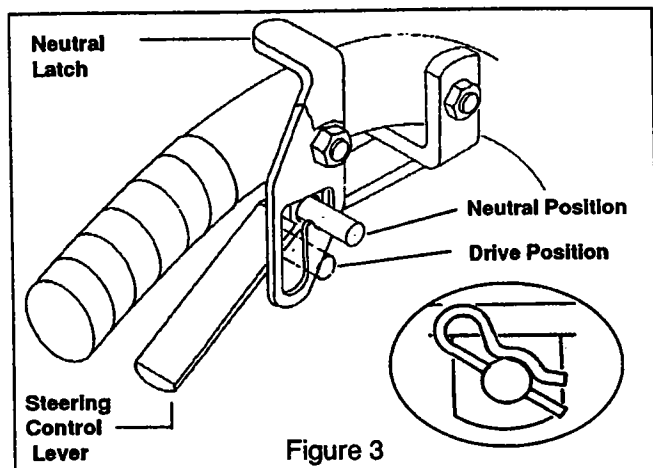

Figure 3

7. Installing speed control rod.

- Thread swivel joint onto speed control rod.
- Insert end of swivel joint through hole in speed control bellcrank and secure with hair pin. Rotate bellcrank forward and down (See figure 4).

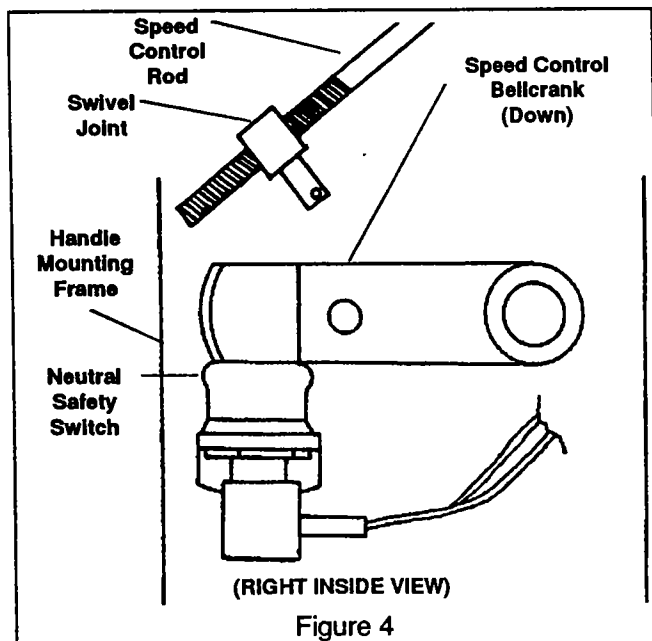

Figure 4

- Shift speed adjustment lever to the neutral position, depress neutral switch with speed control bellcrank, and adjust the speed control rod so that it fits into the hole in the speed adjustment lever. Secure with hairpin.

8. Attach fuel tank (See figure 5) as follows:
- Wrap the straps around the fuel tank to pre-form them, then set aside to be used later.
  - Position the four rubber pads on to the gas tank. 2 - 1/4" thick pads in the strap grooves on top and 2 - 3/8" pads with adhesive bottoms in the strap grooves between the gas tank and handle mounting frame. Attach the adhesive side of the bottom two pads to the handle mounting frame.
  - Position the tank so the SCAG logo is forward. Place the straps around the tank going under the handle mounting frame, secure the strap together in front using (2) two 1/4-20 x 2" slotted machine screws and hex nuts. Tighten screws until the tank will not slide around. Over tightening will damage the tank or straps.
  - Attach the fuel line to the valve on the bottom of the tank.

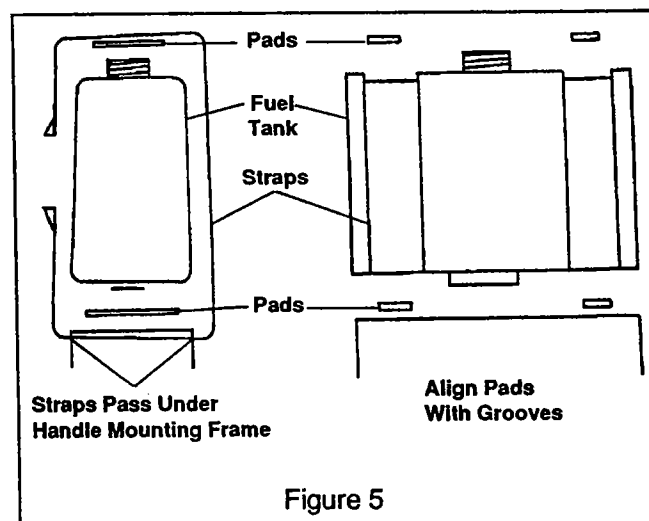

Figure 5

- Check engine oil level, add as necessary .
- Check hydrostatic oil reservoir. Oil level should be 3" from top of reservoir (not top of filler neck). **DO NOT OVERFILL !!!** Add SAE 10W30 motor oil if necessary.
- Fill fuel tank with gasoline and then open shut-off valve under tank. **Check for any leaking fuel.**

## ASSEMBLY INSTRUCTIONS CONT'D

## ADJUSTMENTS

### ATTACHING 52", 61", OR 72" CUTTER DECKS

1. Before beginning, determine which mounting holes are to be used to best suit the cutting height requirements of your customer. High/Medium/Low ranges (See figure 6).
2. Remove belt cover by loosening the wing nuts securing it to the cutter deck.
3. Position cutter deck so that the engine deck is between the mounting brackets of the cutter deck. Install two bolts through the mounting holes selected, secure loosely with a flat washer, lockwasher and hex nut. Tilt the engine deck up or down to align the remaining four holes and secure with remaining hardware.

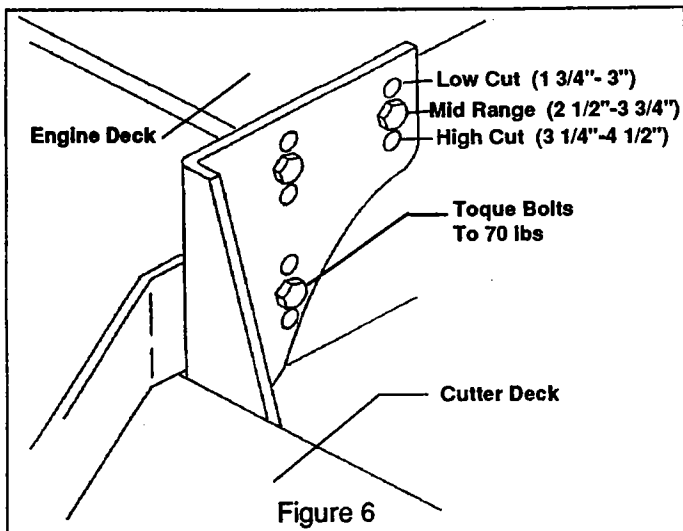

4. Torque cutter deck mounting bolts to 70 ft. lbs..
5. Route belt around engine pulley and install engine belt guide.
6. Connect lower blade clutch control rod to the cam link with flat washer and hair pin.
7. Attach discharge chute to cutter deck using (2) two 5/16-18 x 1" bolts and elastic stop nuts.
8. Attach caster wheel supports to cutter deck using (4) four 5/16-18 x 1" bolts, flat washers and elastic stop nuts.

**NOTE:** Check all hardware to be sure it is tightened properly, also check clearance and routing of drive belts.

### CUTTER DECK DRIVE ADJUSTMENTS

1. Engage blade clutch lever and check for proper over center clearance. There should be about 3/8" between rod and straight edge (See figure 7). Bend the stop tab to adjust clearance.

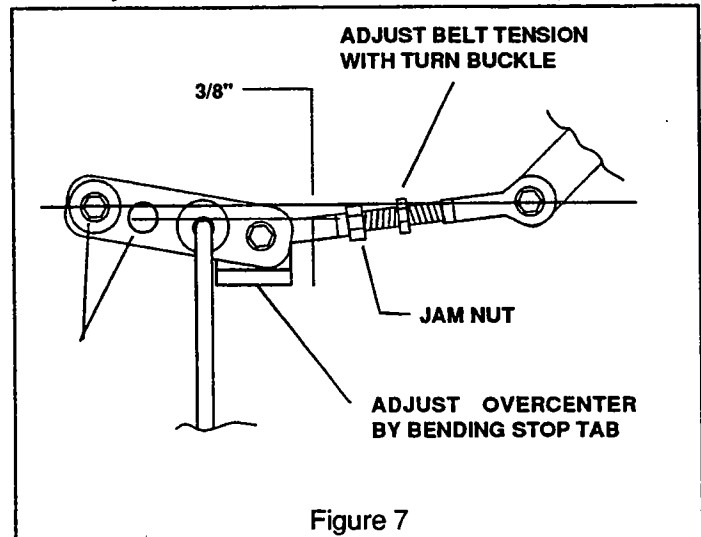

There are two holes drilled into the cam link that you can use for the bolt that secures the cam link to the mounting post welded to the deck. This will allow you to lengthen or shorten the engagement linkage to compensate for belt wear.

2. Adjust belt tension so that the belt moves 1/2" with 10 lbs. of pressure applied between the center and left spindle pulleys (See figure 8). Adjustment is made by loosening the jam nut and tightening/loosening the turn buckle (See figure 7). Belt driving right spindle should be checked the same way. Adjust with J-rod on RH belt tension adjustment idler.

**NOTE:** Belt tension may need to be increased or decreased 1 to 2 lbs. to achieve lowest vibration in belt.

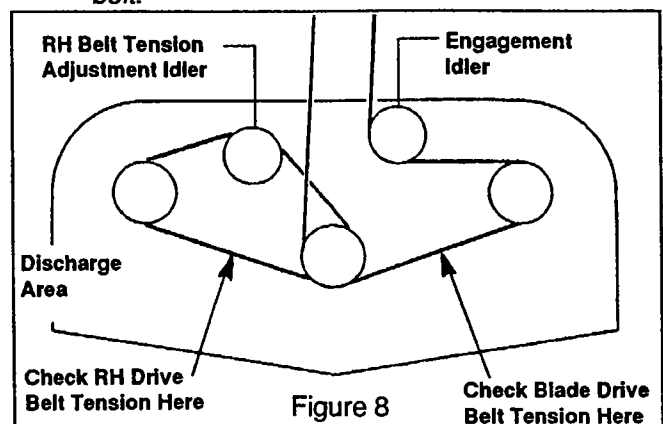

## ADJUSTMENTS CONT'D

### CUTTER DECK ADJUSTMENTS

Due to the many conditions that exist, it is difficult to suggest a setting that will work for every lawn. There are two adjustments that can be made on these decks, pitch and height.

**PITCH** is the angle of the blades (comparing front to rear). A *positive pitch* is when the front (leading) edge of the cutting plane is lower than the rear (trailing) edge, *level pitch* is when both front and rear are the same height, a *negative pitch* is when the leading edge is higher than the rear edge. We suggest that a positive pitch be used when cutting grass. The front of the deck should be 1/4" to 1/2" lower than the rear of the deck.

**HEIGHT** is the nominal distance the blade is off of the ground. This measurement is made with the blades pointed side to side and distance is measured between cutting tip and ground.

### BALL BEARING SPINDLE ASSEMBLY

Adjusting the blade height can be done by moving any number of the five spacers on the blade mounting bolts to the top of the spindle shaft or below the spindle shaft (all blades should be positioned equally). Unit is shipped with one spacer on top and four underneath (see figure 9). For best cut and discharge a minimum of three spacer should be between the blade and spindle.

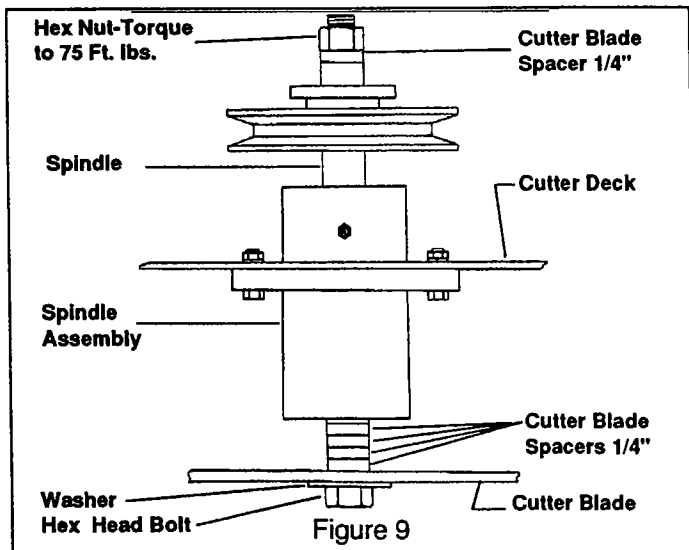

### TAPERED BEARING SPINDLE ASSEMBLY

Adjusting the blade height can be done by moving any number of the four smaller 1/4" spacers on the blade mounting bolts to the top of the spindle shaft or below the spindle shaft. (All blades should be positioned equally). The tapered bearing spindle has a large 1/4" spacer that is installed directly below the spindle housing and is secured to the spindle with two roll pins. The blade can be adjusted all the way up to the spindle assembly if all the smaller 1/4" spacers are removed and installed above the pulley. The larger 1/4" spacer can then be removed along with the roll pins. (Do not install the larger 1/4" spacer above the pulley, store it in a convenient location away from the machine). When any 1/4" spacers are installed above the blades the larger 1/4" spacer must be installed directly below the spindle housing. If a smaller 1/4" spacer is installed directly below the spindle housing and contacts the retaining ring this will cause a spindle failure and not be warrantable. For best cut and discharge a minimum of three spacers should be between the blade and spindle. (See Figure 10)

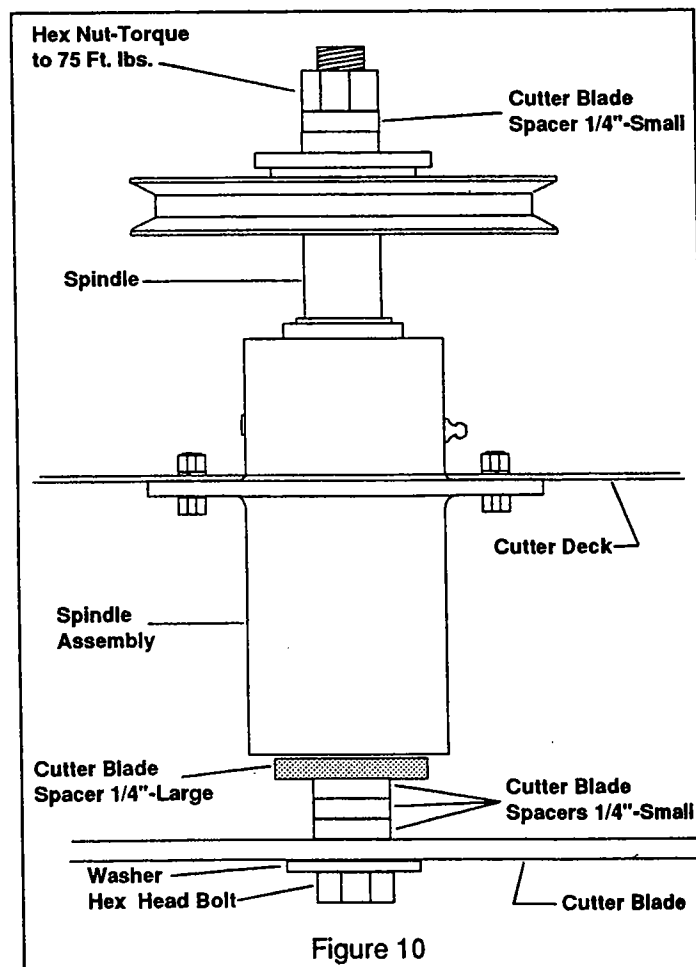



## ADJUSTMENTS CONT'D

Additional range to the cutting height can be achieved by repositioning the cutter deck in relationship to the engine deck (This adjustment can also effect the pitch of the deck). There are 3 positions (See figure 6), suggested mounting is the middle holes. For cutting lower, mount the deck in the top holes. To cut higher, mount the deck in the bottom holes.

Remember to check the cutter deck belt alignment. Shim-ming or attaching the idler mounting bracket from underneath may be necessary to maintain belt life. Caster spacers also can be repositioned to change cutting heights and to change the pitch of the deck (See figure 11).

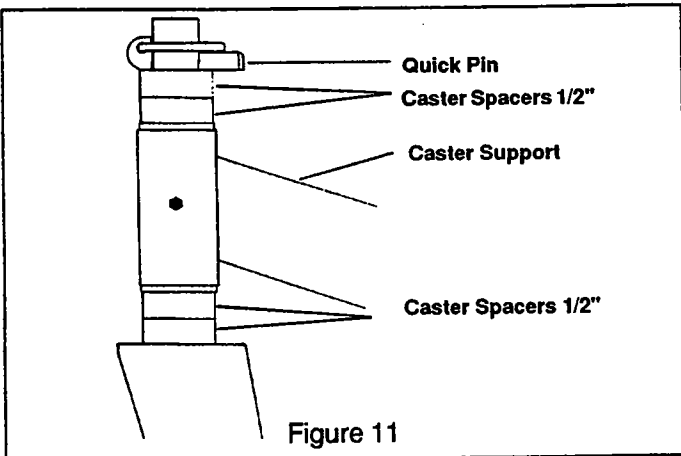

## HYDRAULIC PUMP DRIVE BELT

The hydraulic pump drive belt is spring loaded and does not require tensioning.

## TIRE PRESSURES

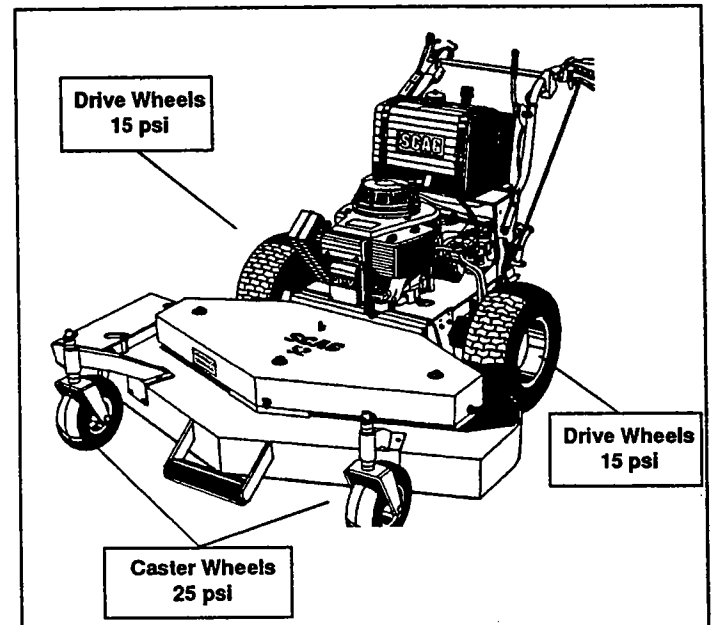

## ADJUSTMENTS CONT'D

### NEUTRAL ADJUSTMENT

This is the only adjustment to properly set neutral.

1. Locate machine in a secure area, away from bystanders, and preferably facing a wall. Raise drive wheels off the ground. Block caster wheels.
2. Remove the steering control rod and the speed control spring from the machine. (See figure 12)
3. Start engine and allow system to warm up for a few minutes.
4. Move the speed adjustment lever up on the handle into a forward speed. This will move the speed adjustment cam away from the cam bearing.
5. If the drive wheels rotate, loosen the bolts on the neutral adjustment handle and move the handle up or down until the wheels are in neutral. (See figure 12)

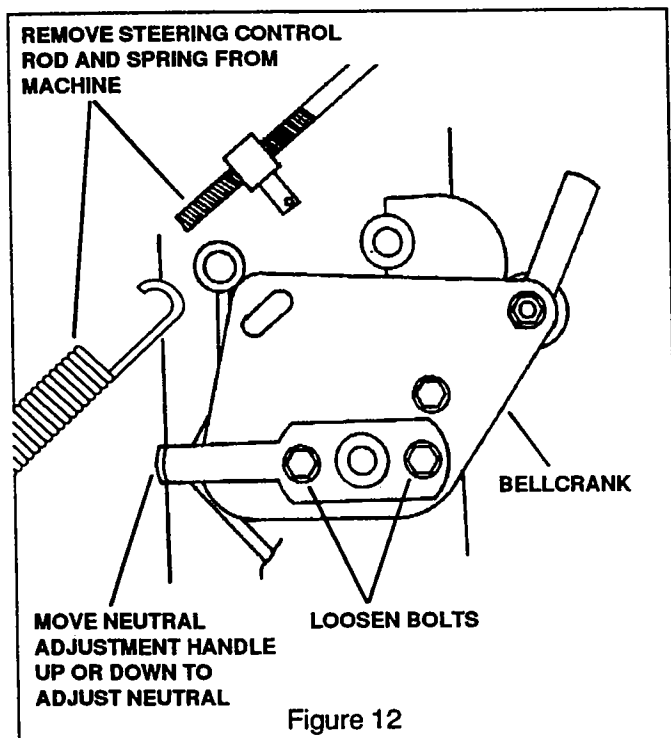

6. Retighten the bolts on the neutral adjustment handle. When tightening the bolts, hold onto the bellcrank to prevent it from rotating and throwing off the neutral adjustment.
7. Turn off engine.
8. The neutral is now adjusted. Do not try to adjust neutral with the speed control rods or the speed adjustment cam.

### STEERING CONTROL ROD ADJUSTMENT

This adjustment is made to allow the steering control lever to be moved out of neutral latch without engaging reverse.

1. Connect the steering control rods into the steering control lever up on the handles. Do not install the hair pin through the rod at this time. (See figure 13)
2. Put the steering control lever into neutral latch. (See figure 13)

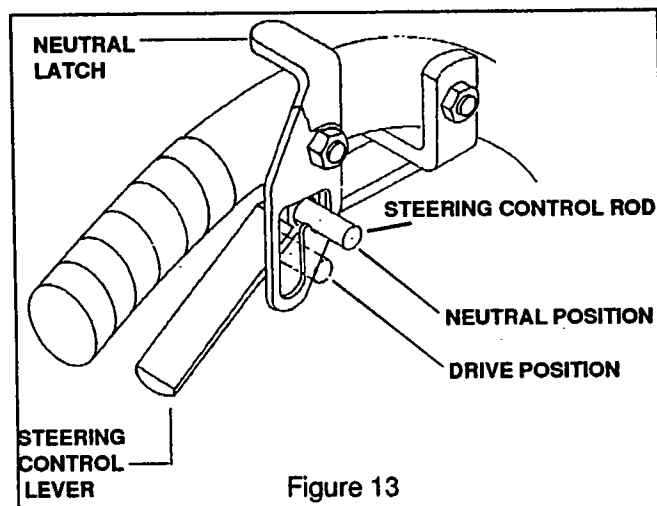

## ADJUSTMENTS CONT'D

3. Turn the swivel joint on the steering control rod until the swivel joint lines up in the center of the slot in the bellcrank. This will allow the control rod to be moved back when shifting out of neutral and not move the bellcrank. (See figure 14)
4. Remove the steering control rod from the machine and install the speed control spring onto the swivel joint and then reconnect the control rod back onto the machine. Make sure that the swivel joint does not turn on the control rod while you are doing this.
5. Install the hair pins into the control rod up at the handle and into the swivel joint.

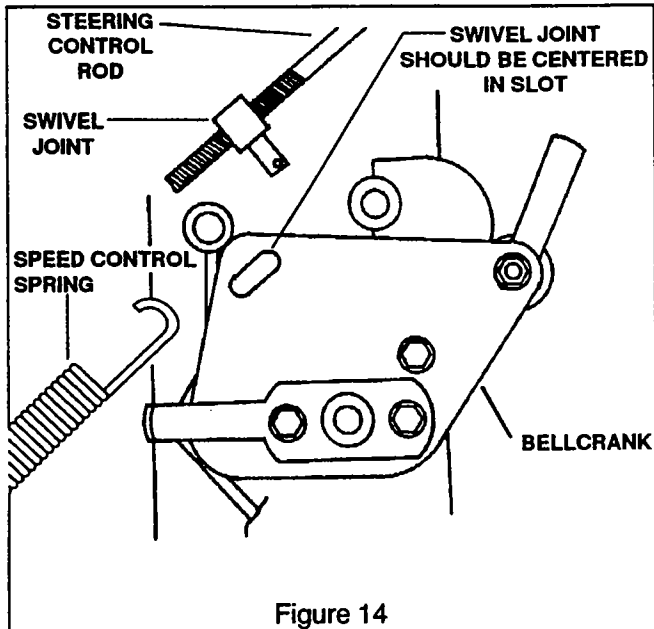

Figure 14

### TRACKING STRAIGHT ADJUSTMENT

This adjustment will allow the machine to travel in a straight line at the normal operating speed.

1. Loosen the two bolts securing the speed adjustment bearing to the bellcrank. (See figure 15)
2. Move the speed adjustment lever, up on the handles, into the neutral position.
3. Place the speed adjustment bearing where it just contacts the speed adjustment cam. (See figure 15)

4. Tighten the two bolts securing the speed adjustment bearing.
5. Put the machine on a flat level surface (preferably on grass) and start engine.

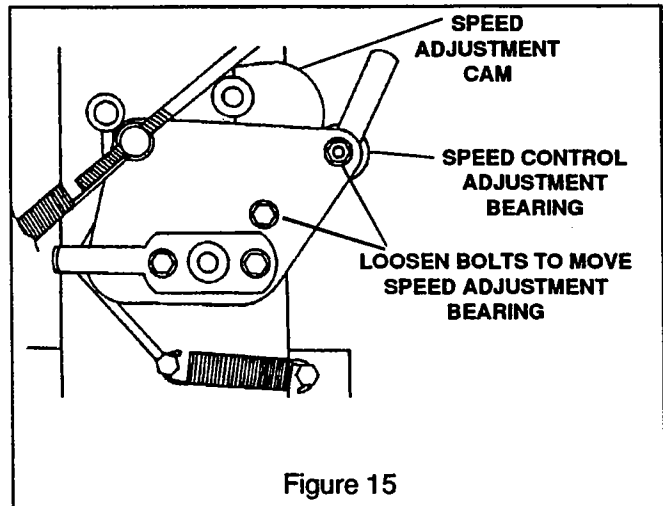

Figure 15

6. Place speed adjustment lever into the forward speed used most often and see if machine tracks straight.
7. If machine pulls to one side, put the speed adjustment lever back into neutral and shut off engine.
8. If the machine pulls to the left, on the left side of the bellcrank, loosen the two securing bolts and move the adjustment bearing 1/16" away from the cam and retighten the bolts. Restart engine and check for tracking straight. (See figure 15)
9. The farther the adjustment bearing is moved away from the cam, the faster that side will drive. Continue adjusting bearing until tracking in a straight line is achieved.
10. Conversely, if machine turns to the right, adjust the right bearing away from the cam.
11. Never move the bearing forward beyond just touching the cam, or reverse will be engaged unintentionally.

## INITIAL RUN-IN

**⚠ WARNING:** Use extreme caution during mower's initial run-in to assure caster wheels are adequately blocked and drive wheels do not inadvertently contact ground. Keep bystanders away from machine. Never allow mower to discharge towards someone. Never leave the machine unattended during the initial run-in.

1. Lubricate all fittings as specified in Lubrication Chart.
2. Locate machine in a secure area, away from bystanders, and preferably facing a wall. Raise drive wheels off ground. Block caster wheels.
3. Start engine and shift speed adjustment lever to mid range. Engage cutter blades. Set throttle for 3/4 of full engine rpm.
4. Run the machine for a few minutes.
5. Declutch cutter blades, shift speed adjustment lever into NEUTRAL, stop engine.
6. Check tension of blade drive belt(s). Adjust if necessary.
7. If necessary, readjust steering control neutral and speed control adjustment neutral as indicated in the Adjustments Section.
8. Check function of all safety interlocks. Make sure that engine will not start unless speed control lever is in neutral and blade clutch is disengaged.
9. Check tire pressure and adjust to:  
Caster Wheels 25 psi.  
Drive Wheels 15 psi.

## OPERATING INSTRUCTIONS

1. Read and understand the instructions on safety before attempting to operate.
  2. Before starting engine:
    - \* Fuel valve must be opened.
    - \* Speed control lever must be in NEUTRAL.
    - \* Blade clutch lever must be in STOP position.
    - \* Neutral latches must be in NEUTRAL LOCK position.
    - \* Key switch on.
    - \* Choke as required.
  3. Start engine. Adjust throttle to desired blade speed.
  4. Engage cutter blades by pushing blade clutch lever forward until it snaps into the ON position. Pull lever back to stop cutter blades.
  5. While squeezing steering control levers with both hands, release both neutral latches.
  6. When steering control levers are released, machine will travel straight. To make a right turn, squeeze RH lever; to turn left, squeeze LH lever.
  7. Shift speed control lever for desired mowing speed.
- NOTE:** *Top speed is suggested only for transport!*
8. TO STOP wheel drive, shift speed control lever into neutral, squeeze both steering levers, lock neutral latches.
  9. For reverse, squeeze up on the steering control levers. Be sure area is clear before backing.
  10. Before turning unit off, be certain blade clutch lever is in the OFF position, neutral latches are in NEUTRAL position, and speed control lever is in NEUTRAL.

## MAINTENANCE

### AIR BLEED PROCEDURE

Air must be bled from hydraulic system when any of the hydraulic drive components are removed and when hydrostatic oil is changed.

1. With oil in reservoir, disconnect hose line from each pump to oil filter (middle front port) at the pumps (see illustration below).
2. Plug disconnected hose lines.
3. Watch for oil to drip at a steady rate from open ports on pumps. When this happens, unplug hose lines and reconnect to ports.
4. Locate machine in a secure area, away from bystanders, and preferably facing a wall. Raise drive wheels off ground. Block caster wheels.
5. Run machine at full forward speed for approximately 30 seconds and then run in reverse for approximately 30 seconds.
6. If neutral needs to be adjusted, follow procedure in adjustments section of this manual.

### FREEWHEEL POSITION

To move machine around without having the engine running, rotate dump valve levers located on the back left hand side of the pump approximately 1/2 turn. Levers must be returned to original position in order to operate machine.

### CUTTER BLADES

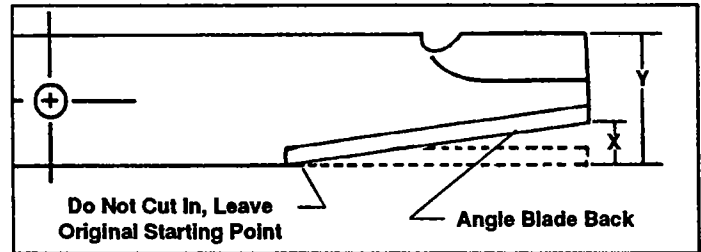

Do not sharpen (X) beyond 1/3 of the width (Y) of the blade.

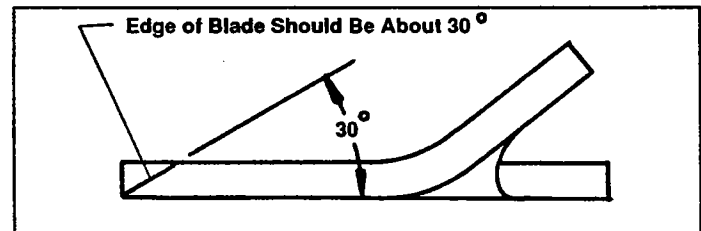

Suggestion: Dress the blade with a file. Using a wheel grinder may burn the blade. Be careful when handling sharp blades

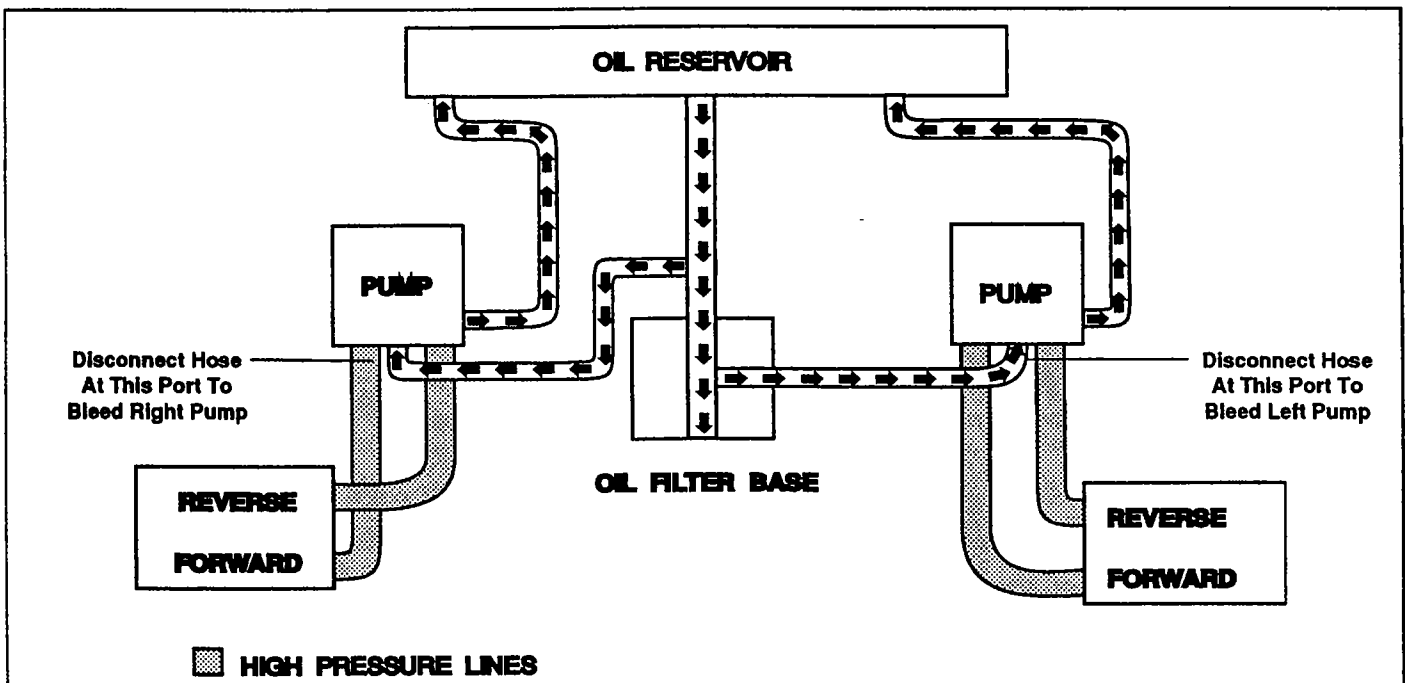

## LUBRICATION & MAINTENANCE

		PROCEDURE	COMMENTS
<b>Break-In</b> 8 Hours (Daily) 40 Hours (Weekly) 100 Hours (Biweekly) 200 Hours (Monthly)	X	Check all hardware for proper tightness	Adjust oil level as needed - SAE 10W30
	X	Change engine oil and filter at 5 hours	
	X	Change hydrostatic oil filter at 20 hours	
	X	Check engine oil	Do not over fill
	X	Remove debris from under belt cover	MORE OFTEN IF NEEDED
	X	Sharpen cutter blades	" " "
	X	Clean air filter	" " "
	X	Clean blower screen	" " "
	X	Grease spindle bearings 2 pumps of hand gun	Or until grease comes out of relief valve
	X	Check battery acid level	Distilled water only
X	Check tire pressure	Add or adjust as required	
X	Change engine oil	MORE OFTEN IF NEEDED	
X	Replace air filter	MORE OFTEN IF NEEDED	
X	Grease caster wheel bearings	Chassis grease	
X	Grease caster wheel pivots	Chassis grease	
X	Grease idler arm pivots	Chassis grease	
X	Change engine oil filter	See engine mfg. information	
X	Check all hardware for proper tightness	See engine mfg. information	
X	Check hydrostatic fluid reservoir level		
X	Clean and adjust spark plugs		
		<b>Every 500 hours</b>	
		Drain Hydraulic System and replace fluid	Use SAE 10W-30 motor oil
		Change hydrostatic oil filter	Clean area before removing filter

\* Depending on climate and environment, lubrication may be required every 8 to 40 hours.

\* Do not over grease as this may damage seal.

+ Compatible Greases:

US Lithium MP White Grease 2125

Lidok EP #2 found at industrial shops

Ronex MP found at Exxon Service Stations

Shell Alvania #2 found at Shell Service Stations

Mobilux #2 found at Mobil Service Stations

Super Lube M EP #2 and Super Stay-M #2 found at Conoco Service Station

## 36" CUTTER DECK

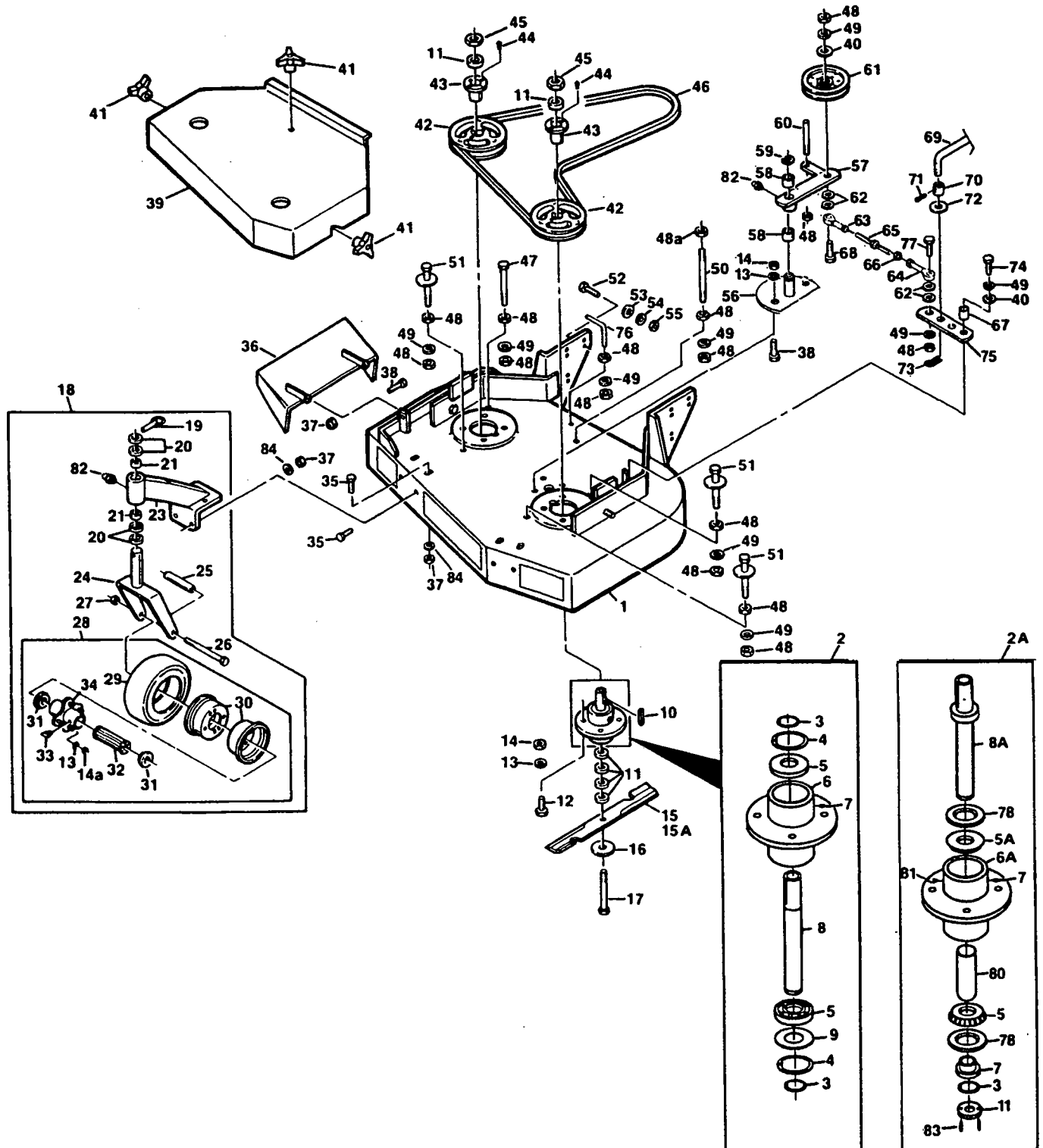

## 36" CUTTER DECK

Ref. Part No. Number	Description	Ref. Part No. Number	Description
1	46087 Cutter Deck (Includes Decals)	40a	Washer, 13/32 x 13/16 x 16 ga.
2	46029 Cutter Spindle Assy. (Includes Items 3-9)	41	04029-03 Wing Nut, 3/8-16
2A	46400 Cutter Spindle Assy.	42	48127 Pulley (Includes Items 43-44)
3	04050-04 Retaining Ring, 1" Ext.-Inverted	43	48141 Tapered Hub
4	04050-07 Retaining Ring, 2-7/16 Int.bsc	44	Hex Hd. Bolt, 1/4-20 x 3/4
5	48101-02 Bearing, Spindle	45	Hex Nut, 5/8-11
5A	48668 Tapered Bearing	46	48204 Belt, Blade Drive
6	41001 Spindle Housing	47	Hex Hd. Bolt, 3/8-16 x 5
6A	41007 Spindle Housing	48	Hex Nut, 3/8-16
7	48114-02 Grease Fitting, Str., 5/16 Serr	48a	Hex Nut, 3/8-16 Cir Locknut
8	43001-02 Spindle, Cutter Blade	49	Lockwasher, Spring 3/8
8A	45391 Spindle Shaft	50	04004-02 Support, Belt Cover
9	04041-02 Washer, 1-5/16 x 2-7/16 x 16 ga.	51	45098 Belt Guide
10	04063-08 Key, 1/4 x 1/4 x 2	52	Hex Hd. Bolt, 7/16-14 x 1-1/4
11	43038 Spacer, Cutter Blade - Small	53	Washer, 15/32 x 59/64 x 16 ga.
11A	43201 Spacer, Cutter Blade - Large	54	Lockwasher, Spring, 7/16
12	Hex Hd. Bolt, 5/16-18 x 1-1/4	55	Hex Nut, 7/16-14 Elastic Stop
13	Lockwasher, Spring, 5/16	56	45423 Idler Pivot
14	Hex Nut, 5/16-18	57	46434 Idler Arm Assy. (Includes Items 82 & 58)
14a	Hex Nut, 5/16-24	58	48100-02 Bronze Bearing (Gray)
15	48108 Cutter Blade 18"	59	04050-05 Retaining Ring, 1 1/8" Ext., -E"
15a	48185 Cutter Blade 18" Hi Lift	60	04004-04 Stud
16	04040-10 Flat Washer, 5/8 W	61	48269 Idler Pulley, Belt Clutch
17	04001-41 Hex Hd. Bolt, 5/8-11 x 9-1/2	62	Flat Washer, 3/8"
18	46079 Caster Assembly (Includes Items 19-28)	63	48544 Rod End - L.H. Thd (Silver)
19	04066-01 Quick Pin	64	48464 Rod End - R.H. Thd (Gold)
20	43037-01 Spacer, Caster Yoke, 1/2" long	65	48590 Link, Turnbuckle
21	48100-01 Bronze Bearing	66	Hex Nut, 3/8-24
23	46082 Support Assembly (Includes Items 21, 82)	67	43042 Sleeve, Clutch Rod
24	45006 Caster Yoke	68	Hex Hd. Bolt, 3/8-16 x 2-3/4
25	43022 Sleeve, Caster Wheel Brg.	69	44064 Blade Clutch Rod, Lower
26	04001-37 Hex Hd. Bolt, 1/2-13 x 5-1/2	70	43043 Sleeve, Clutch Rod
27	Hex Locknut, 1/2-13	71	Cotter Pin, 3/32 x 1
28	48307 Wheel Assy. (Includes 13-14a, 29-34)	72	Washer, 33/64 x 1 x 16 ga.
29	48307-02 Tire Only Caster Wheel	73	04062-01 Hair Pin, Large
NS	48006-03 Inner Tube only	74	Hex Hd. Bolt, 3/8-16 x 1
30	48307-04 Rim Pair, Caster Wheel	75	421107 Cam Link
31	48006-07 Retainer, Bearing, Caster Wheel	76	44009 Belt Guide
32	48006-06 Roller Bearing, Caster Wheel	77	Hex Head Bolt, 3/8-16 x 1 1/2"
33	48114-03 Grease Fitting, 45 1/4-28	78	48681 Seal, Cutter Spindle
34	48006-05 Hub Assembly	79	43217 Spindle Bushing
35	Hex Hd Bolt, 5/16-18 x 1"	80	43218 Sleeve, Cutter Spindle
36	45100 Discharge Chute	81	48677 Relief Fitting, Cutter Spindle
37	Hex Nut, 5/16-18 Elastic Stop	82	48114-04 Grease Fitting, Cutter Spindle
38	Hex Hd Bolt, 5/16-18 x 1	83	Roll Pin, 1/8 x 1/2"
39	46085 Belt Cover Assembly (Includes Decal)	84	Flat Washer, 5/16"
40	Washer, 25/64 x 15/16 x 12 ga.		

\* Common hardware which should be purchased locally. All bolts are Grade 5 plated, all other fasteners are zinc plated.



## 48", 52", 61", & 72" CUTTER DECKS

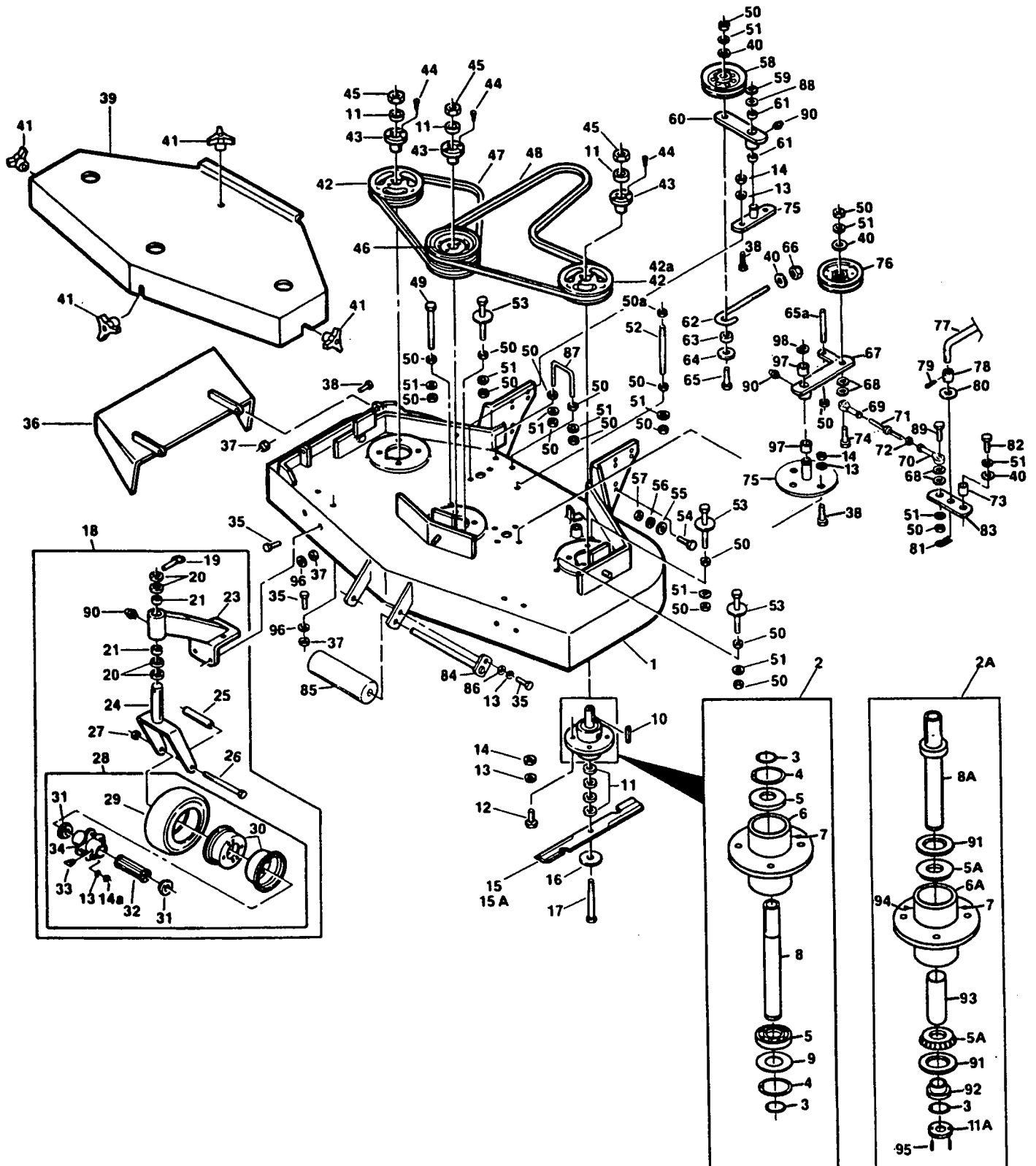

## 48", 52", 61", & 72" CUTTER DECKS

Ref. Part No. No.	Description	48	52	61	72	Ref. Part No. No.	Description	48	52	61	72
1 46088	Cutter Deck (Includes decals)	x				45 *	Hex Nut, 5/8-11	x	x	x	x
1 46163	Cutter Deck (Includes decals)		x			46 48412	Pulley, Double (Includes 43-44)	x	x	x	
1 46119	Cutter Deck (Includes decals)			x		46 48302	Pulley, Double (Includes 43-44)				x
1 46194	Cutter Deck (Includes decals)				x	47 48087	Belt, RH Blade Drive	x			
2 46020	Cutter Spindle Assy. Ball Bearing	x	x	x	x	47 48285	Belt, RH Blade Drive		x		
2A 46400	Spindle Assembly, Tapered Bearing	x	x	x	x	47 48265	Belt, RH Blade Drive			x	
3 04050-04	Retaining Ring, 1" Ext.-Inverted	x	x	x	x	47 48295	Belt, RH Blade Drive				x
4 04050-07	Retaining Ring, 2-7/16" Int.basic	x	x	x	x	48 48089	Belt, Blade Drive	x			
5 48101-02	Bearing, Cutter Spindle	x	x	x	x	48 48286	Belt, Blade Drive		x		
5A 48658	Tapered Bearing	x	x	x	x	48 48264	Belt, Blade Drive			x	
6 41001	Spindle Housing	x	x	x	x	48 48296	Belt, Blade Drive				x
6A 41007	Spindle Housing, Tapered Bearing	x	x	x	x	49 *	Hex Hd. Bolt, 3/8-16 x 5"	x	x	x	
7 48114-02	Grease Fitting Str. 5/16 Serr.	x	x	x	x	49 45098	Belt Guide				x
8 43001-02	Spindle, Cutter Blade	x	x	x	x	50 *	Hex Nut, 3/8-16	x	x	x	x
8A 45391	Spindle Shaft, Tapper Bearing	x	x	x	x	50a *	Hex Nut, 3/8-16, Centerlock	x	x	x	x
9 04041-02	Washer, 1-5/16 x 2-7/16 x 16 ga.	x	x	x	x	51 *	Lockwasher, Spring, 3/8	x	x	x	x
10 04063-08	Key, 1/4 x 1/4 x 2	x	x	x	x	52 04004-02	Support, Belt Cover	x	x	x	x
11 43038	Spacer, Cutter Blade	x	x	x	x	53 45098	Belt Guide	x	x	x	x
11A 43201	Spacer, Cutter Blade, Tapered	x	x	x	x	54 *	Hex Hd. Bolt, 7/16-14 x 1-1/2	x	x	x	x
12 *	Hex Hd. Bolt, 5/16-18 x 1-1/4	x	x	x	x	55 *	Washer, 15/32 x 59/64 x 16 ga.	x	x	x	x
13 *	Lockwasher, Spring, 5/16	x	x	x	x	56 *	Lock Washer, Spring, 7/16	x	x	x	x
14 *	Hex Nut, 5/16-18	x	x	x	x	57 *	Hex Nut, 7/16-14	x	x	x	x
14a *	Hex Nut, 5/16-24	x	x	x	x	58 48181	Idler Pulley, "V" Groove	x	x	x	x
15 48110	Cutter Blade 16-1/2"	x				59 04050-02	Retaining Ring, 3/4" Ext."E"	x	x	x	x
15 48108	Cutter Blade 18"		x			60 46081	Idler Arm Assy. (Includes 82 & 61)	x	x	x	x
15 48111	Cutter Blade 21"			x		61 48100-05	Bronze Bearing	x	x	x	x
15 48112	Cutter Blade 24"				x	62 43028	J Rod, Idler Puff	x	x	x	x
15a 48184	Cutter Blade 16-1/2" Hi Lift	x				63 43077	Spacer, J Plat Rod	x	x	x	x
15a 48185	Cutter Blade 18" Hi Lift		x			64 04041-12	Washer, 3/8 x 1-1/2 x 16 ga.	x	x	x	x
15A 48304	Cutter Blade 21" Hi Lift			x		65 *	Hex Hd. Bolt, 3/8-16 x 2-1/4	x	x	x	x
16 04040-10	Flat Washer, 5/8" W	x	x	x	x	65a 04004-04	Stud	x	x	x	x
17 04001-41	Hex Hd. Bolt, 5/8-11 x 9-1/2"	x	x	x	x	66 *	Hex Nut, 3/8-16 Elastic Stop	x	x	x	x
18 46079	Caster Assy, Comp. (incl. 19-28)	x	x	x	x	67 46434	Idler Arm (Includes Items 97, 90)	x	x	x	x
19 04066-01	Quick Pin	x	x	x	x	68 *	3/8" Flat Washer	x	x	x	x
20 43037-01	Spacer, Caster Yoke, 1/2" thick	x	x	x	x	69 48544	Rod End L.H. THD. (Silver)	x	x	x	x
21 48100-01	Bronze Bearing	x	x	x	x	70 48464	Rod End R.H. THD. (Gold)	x	x	x	x
23 46082	Support Assy. (incl. 21-90)	x	x	x	x	71 48590	Link, Turnbuckle	x	x	x	x
24 45006	Caster Yoke	x	x	x	x	72 *	3/8"-24 Hex Nut	x	x	x	x
25 43022	Sleeve, Caster Wheel Bearing	x	x	x	x	73 43042	Sleeve, Cam Clutch	x	x	x	x
26 04001-37	Hex Hd Bolt, 1/2-13 x 5-1/2"	x	x	x	x	74 *	Hex Hd Bolt, 3/8-16 x 2-3/4	x	x	x	x
27 *	Hex Locknut, 1/2-13	x	x	x	x	75 45329	Idler Pivot	x	x	x	x
28 48307	Wheel Assy. (incl. 13-14, 29-34)	x	x	x	x	76 48269	Idler Pulley, Belt Clutch	x	x	x	x
29 48307-02	Tire only, Caster Wheel	x	x	x	x	77 44064	Blade Clutch Rod, Lower	x	x	x	x
48006-03	Inner Tube only, Caster Wheel	x	x	x	x	78 43043	Sleeve, Clutch Rod	x	x	x	x
30 48307-04	Rim Pair, Caster Wheel	x	x	x	x	79 *	Cotter Pin, 3/32 x 1	x	x	x	x
31 48006-07	Retainer, Bearing, Caster Wheel	x	x	x	x	80 *	Washer, 33/64 x 1 x 16 ga.	x	x	x	x
32 48006-06	Roller Bearing, Caster Wheel	x	x	x	x	81 04062-01	Hair Pin Large	x	x	x	x
33 48114-03	Grease Fitting 45 deg. 1/4-28	x	x	x	x	82 *	Hex Hd Bolt, 3/8-16 x 1	x	x	x	x
34 48006-05	Hub Assy. (incl. bolts)	x	x	x	x	83 421107	Cam Link	x	x	x	x
35 *	Hex Hd. Bolt, 5/16-18 x 3/4"	x	x	x	x	84 45046	Roller Shaft	x	x	x	x
36 45029	Discharge Chute	x		x	x	85 48038	Guide Roller		x	x	x
36 45100	Discharge Chute		x			86 *	Flat Washer, 11/32 x 11/16 x 16 ga.	x	x	x	x
37 *	Hex Nut, 5/16-18 Elastic Stop	x	x	x	x	87 44008	Belt Guide	x	x	x	x
38 *	Hex Hd. Bolt, 5/16-18 x 1	x	x	x	x	88 *	Flat Washer, 3/4 x 1-1/4 x .035	x	x	x	x
39 46086	Belt Cover (Includes decals)	x				89 *	3/8-16 x 1 1/2" Hex Head Bolt	x	x	x	x
39 46184	Belt Cover (Includes decals)		x			90 48114-04	Grease Fitting	x	x	x	x
39 46121	Belt Cover (Includes decals)			x		91 48681	Saal	x	x	x	x
39 46312	Belt Cover (Includes decals)				x	92 43217	Spindle Bushing	x	x	x	x
40 *	Washer 25/64 x 15/16 x 12 ga.	x	x	x	x	93 43216	Sleeve, Cutter Spindle	x	x	x	x
41 04029-03	Wing Nut, 3/8-16	x	x	x	x	94 48677	Relief Fitting, Cutter Spindle	x	x	x	x
42 48127	Pulley (Includes 43-44)	x	x	x	x	95 *	Roll Pin, 1/8 x 1/2"	x	x	x	x
42a 48299	Pulley (Includes 43-44)				x	96 *	Flat Washer, 5/16"	x	x	x	x
43 48141	Tapered Hub	x	x	x	x	97 48100-02	Bronze Bearing	x	x	x	x
44 *	Hex Hd. Bolt, 1/4-20 x 3/4	x	x	x	x	98 04050-05	Retaining Ring 1 1/8 Ext. "E"	x	x	x	x

## ENGINE DECK

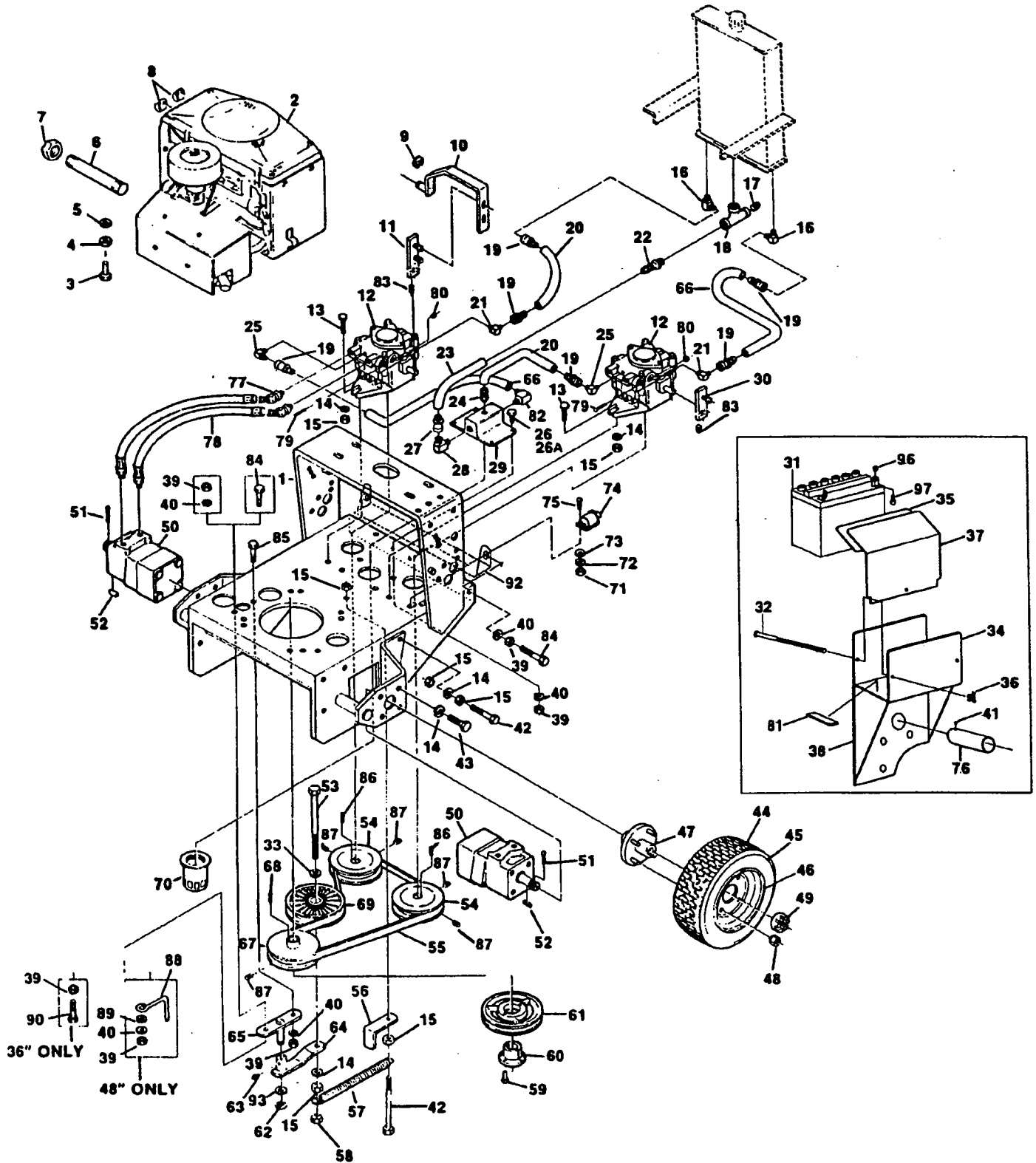

## ENGINE DECK

Ref. No.	Part Number	Description	14KA	14KH	18KH	20KHE
1	45339	Engine Deck (16" Wide)	x	x		
1	45270	Engine Deck (20" Wide)	x	x	x	x
2a	48528	Engine 14H Kawasaki	x			
2a	48357	Engine 14HP Kohler		x		
2b	48268	Engine 18HP Kohler (MV18 PS-58511)			x	
2b	48358	Engine 20HP Kohler El. SL (MV20 PS-57508)				x
3	*	Bolt, Hex Hd. Metric 8 x 30	x	x		
3	*	Hex Hd. Bolt, 5/16-18 x 1-1/2			x	x
4	*	Hex Nut, 3/16-18 Elastic Stop			x	x
5	*	Lockwasher, 5/16 Spring	x	x	x	x
6	48431	Pipe, 4.75" Nipple			x	x
7	48257	Pipe Cap			x	x
8	48059-01	Fuel Hose Clamp	x	x	x	x
9	04050-10	Retaining Ring, 1/2 "E"	x	x	x	x
10	45283	Shaft Widmt. - RH Pump Control	x	x	x	x
11	46324	Lever Assembly, Pump Control - RH	x	x	x	x
12	48551	Pump, Sunstrand BDP-10L117	x	x	x	x
13	*	Bolt, Carnage, 3/8-16 x 1-1/4	x	x	x	x
14	*	Lockwasher, 3/8	x	x	x	x
15	*	Hex Nut, 3/8-16	x	x	x	x
16	48484-01	Elbow, 90 deg. Female 1/4 NPT to 1/4 JIC Male	x	x	x	x
17	48731	Plug, 3/8 NPT Magnetic	x	x	x	x
18	48491	Tee, Galvanized 3/8 NPT	x	x	x	x
19	48353-02	Coupling, 7/16-20 SAE Flare Swivel to 1/4" Hose Push On	x	x	x	x
20	48482-04	Hose, 1/4" ID - 10" Long	x	x	x	x
21	48350-04	Elbow, 90 deg. 7/16-20 JIC to 7/16-20 "O" Ring	x	x	x	x
22	48352-03	Coupling, 3/8 Straight Male NPT to 1/2" Hose Push On	x	x	x	x
23	48351-05	Hose, 1/2" ID, 12" Long	x	x	x	x
24	48486-01	Elbow, 90 deg. Male 1/4 NPT to 1/4" Hose Push On	x	x	x	x
25	48350-03	Elbow, 90 deg.	x	x	x	x
26	*	Bolt, Hex Hd., 5/16-18 x 1" (For 16")	x	x		
26	*	Bolt, Hex Hd., 5/16-18 x 2-1/2 (For 20")	x	x	x	x
27	48353-01	Coupling, 3/4-16 SAE Flare Swivel to 1/2" Hose Push On	x	x	x	x
28	48489-02	Elbow, 90 deg. Male 3/4-16 JIC to 1/2" Male NPT	x	x	x	x
29	48471	Oil Filter Base (Includes item 70)	x	x	x	x
30	46323	Lever Assembly, Pump Control - LH	x	x	x	x
31	48015	Battery				x
32	*	Carnage Hd. Bolt, 1/4-20 x 6				x
33	*	Flatwasher, 3/8 (406 x 812 x .065)	x	x	x	x
34	42802	Battery Box				x
35	48099	Pad			x	
36	04029-01	Wing Nut, 1/4-20				x
37	42392	Battery Cover				x
38	45384	Battery Support				x
39	*	Hex Nut, 5/16-18	x	x	x	x
40	*	Lockwasher, 5/16	x	x	x	x
41	04011-06	Screw, 10-32 x 3/4" Self Tap	x	x	x	x
42	*	Bolt, Hex Hd., 3/8-16 x 2-3/4	x	x	x	x
43	*	Bolt, Hex Hd., 3/8-16 x 1	x	x	x	x
44	48468	Wheel Assembly (Includes 45, 46, 47, 48)	x	x	x	x
45	48004-02	Tire, 16 x 6.50, 2 ply	x	x	x	x
46	48004-04	Rim Assembly	x	x	x	x
47	48468-05	Wheel Hub (Includes item 48)	x	x	x	x
48	48004-06	Bolt and Nut	x	x	x	x
49	04027-02	Hex Castle Nut, 3/4-28 UNEF	x	x	x	x
50	48437	Motor, White RS	x	x	x	x
51	*	Cotter Pin, 3/32 x 1-1/4	x	x	x	x
52	04063-15	Key, 3/16 x 3/16 x .75	x	x	x	x
53	*	Bolt, Hex Hd., 3/8-16 x 2-1/4	x	x	x	x

\* Common hardware which should be purchased locally. All bolts Grade 5 plated, all other fasteners zinc plated.

ENGINE DECK CONTINUED ON FOLLOWING PAGE

## ENGINE DECK CONT'D

Ref. Part					
No.	Number	Description	14KA	14KH	18KH 20KHE
54	48586	Pulley, Pump Shaft	X	X	X X
55	48553	Belt, Pump Drive (For 16")	X	X	X X
55	48587	Belt, Pump Drive (For 20")	X	X	X X
56	42199	Belt Guide, Cutter - Rear (For 16")	X	X	X X
56	42692	Belt Guide, Cutter - Rear (For 20")	X	X	X X
57	48051	Spring, Pump Belt Idler	X	X	X X
58	*	Center Locknut, 3/8-16	X	X	X X
59	*	Bolt, Hex Hd., 1/4-20 x 3/4	X	X	X X
60	48141	Taper Hub (for 48127)	X	X	X X
60	48378-03	Taper Hub (for 48378)			X
61	48127	Pulley, Cutter Drive (Includes Hub)	X	X	X X
61	48378	Pulley, Cutter Drive (Includes Hub)			X
62	04050-02	Retaining Ring, 3/4 Ext. - "E"	X	X	X X
63	48114-01	Grease Fitting	X	X	X X
64	46340	Idler Arm, Traction Belt (Includes bushings and grease fitting)	X	X	X X
65	48212	Pivot, Idler Arm	X	X	X X
66	48482-05	Hose, 1/4" ID - 12" Long	X	X	X X
67	48422	Pulley, Pump Drive	X	X	X X
67	48423	Pulley, Pump Drive			X
68	04063-03	Key, 1/4 x 1/4 x 2-1/2	X	X	X X
69	48473	Pulley, Idler - Pump Drive	X	X	X X
70	48462-01	Oil Filter	X	X	X X
71	*	Hex Nut, #10-32	X	X	X X
72	*	Lockwasher, #10 Ext. Tooth	X	X	X X
73	*	Washer (.219 x .500 x .049)	X	X	X X
74	48305	Switch, Clutch Safety (black)	X	X	X X
75	*	Phillips Hd. Machine Screw, 10-32 x 1/2	X	X	X X
76	421001	Muffler Extension			X
77	48485-01	Elbow, 45 degree	X	X	X X
78	48682	Hose, Pump to Motor	X	X	X X
79	*	Screw, Phillips Rd. Head, 1/4-20 x 2	X	X	X X
80	*	Hex Nut, 1/4-20 Elastic Stop	X	X	X X
81	48661	Pad, Rubber			X
82	48352-02	Coupling, 1/4 straight Male NPT to 1/4 Hose Push-on	X	X	X X
83	04015-06	Setscrew, #10-32 x 1" Socket Hd.	X	X	X X
84	*	Bolt, Hex Hd., 5/16-18 x 1-1/2	X	X	X X
85	*	Bolt, Hex Hd., 5/16-18 x 1	X	X	X X
86	04063-14	Key, 5.0 x 5.0 x 25mm	X	X	X X
87	04012-04	Setscrew, 5/16-18 x 3/8 Socket Hd.	X	X	X X
88	44008	Belt Guide	X	X	X X
89	*	Flat Washer, 25/64 x 15/16 x 12 ga.	X	X	
90	*	Bolt, Hex Hd., 5/16-18 x 3-3/4	X	X	
NS	43096	Spacer, Oil Filter (For 20" only)	X	X	X X
92	45418	Pully Guard (For 16")	X	X	
92	45419	Pulley Guard (For 20")	X	X	X X
93	04041-08	Flatwasher, 3/4"	X	X	X X
94	04041-08S	Flatwasher, 49/64 x 1-1/4 x .035	X	X	X X
95	*	Bolt, Hex Hd., 1/4-20 x 1/2			X
96	*	Hex Nut, 1/4-20			X

\* Common hardware which should be purchased locally. All bolts Grade 5 plated, all other fasteners zinc plated.

## REPLACEMENT DECALS



48314  
Decal - Scag's Logo  
(Located On Cutter Deck Cover - Top Surface)



48072  
Decal - Heavy Duty Commercial  
(Located On Cutter Deck Cover - Front Well)



48079  
Decal - Key Switch  
(Located Near Keyswitch)



72 48327  
61 48320  
52 48319  
48 48318  
36 48316  
(Located On Belt Cover)



48712  
Decal - Caution Belt Cover  
(Located On Cutter Deck Top Surface)



48713  
Decal - Caution Read Operators Manual  
(Located Top Of Hydraulic Reservoir)

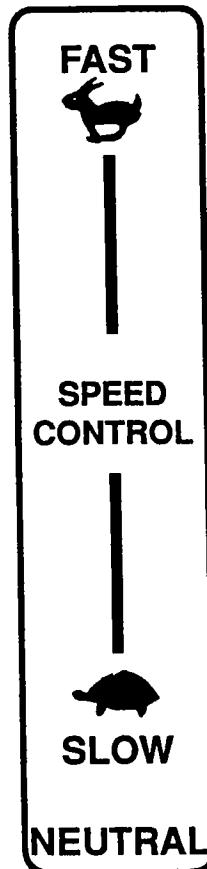

48524  
Decal - Speed Control  
(Located On Shift Quadrant)

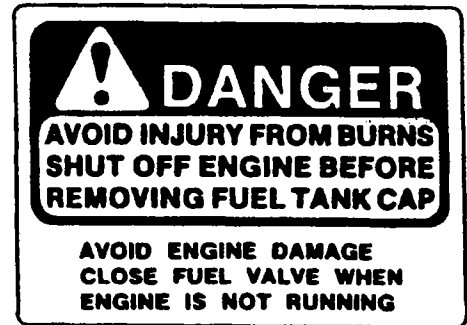

48281  
Decal - Operator Warning  
Fuel Fill  
(Located On Top of Fuel Tank)

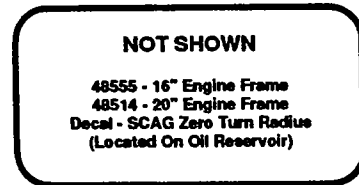

48555 - 16" Engine Frame  
48514 - 20" Engine Frame  
Decal - SCAG Zero Turn Radius  
(Located On Oil Reservoir)

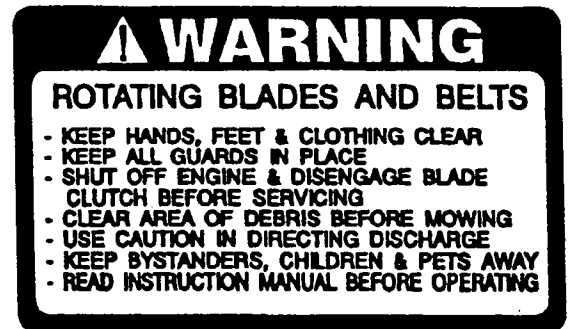

48073  
Decal - Danger, Rotating Blades  
(Located On Cutter Deck Cover Near Discharge Chute)



48071  
Decal - O.P.E.I. Safety  
(Located On Cutter Deck Near Discharge Chute)

## HANDLE ASSEMBLY

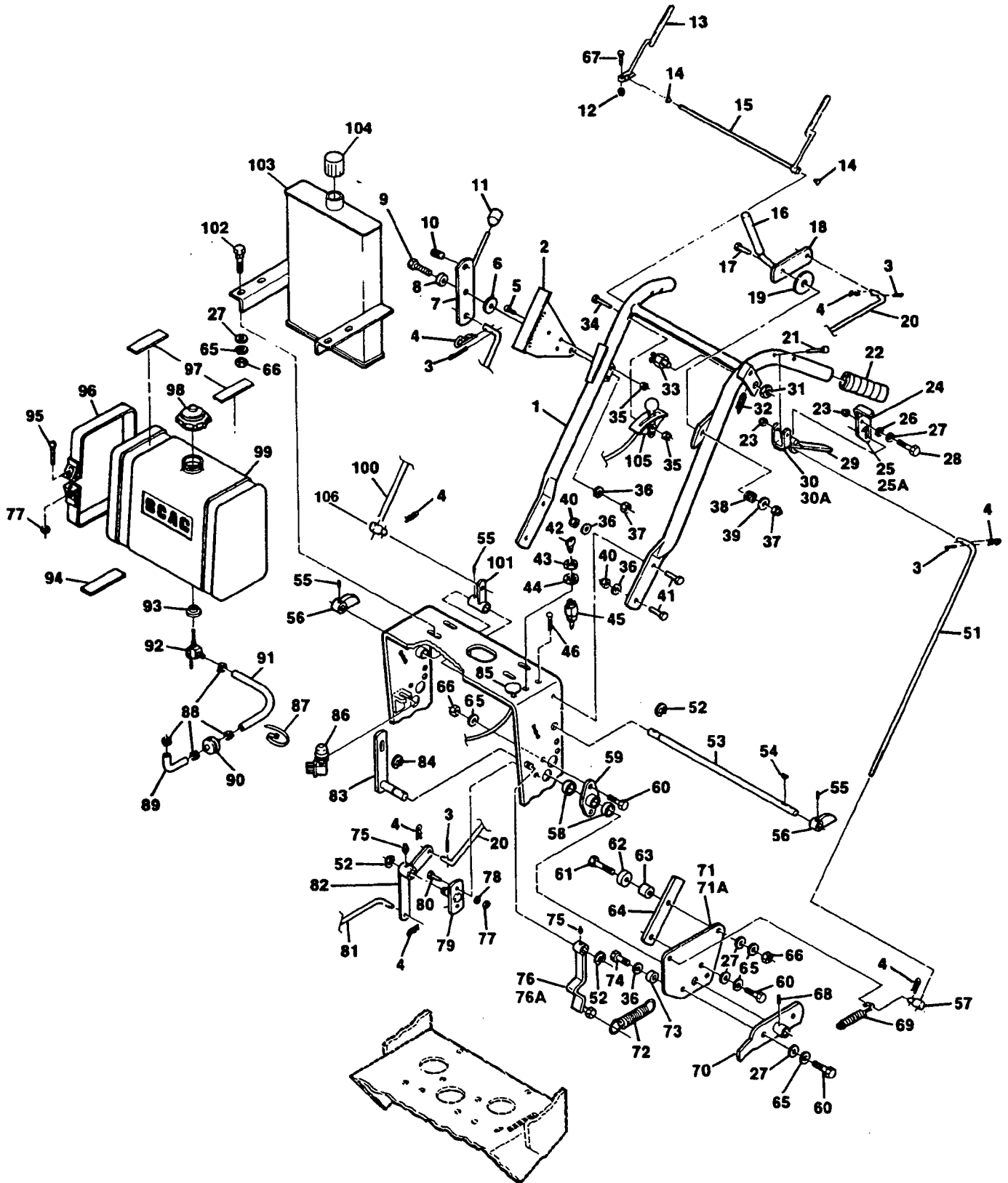

## HANDLE ASSEMBLY

Ref. No.	Part Number	Description	14KA	14KH	18KH	20KE
1	45341	Handle Assembly (For 16")	X	X		
1	45280	Handle Assembly (For 20")	X	X	X	X
2	42675	Quadrant, Speed Control	X	X	X	X
3	*	Cotter Pin, 3/32 x 3/4	X	X	X	X
4	04062-02	Hair Pin, Small	X	X	X	X
5	04014-01	Capscrew, 1/4-20 x .75 Flat Hd. Hex Socket	X	X	X	X
6	*	Lockwasher, 3/8	X	X	X	X
7	45282	Speed Adjustment Lever	X	X	X	X
8	43086	Bushing, Speed Adjustment Lever	X	X	X	X
9	*	Bolt, Hex Hd., 3/8-16 x 1-1/2	X	X	X	X
10	48493-01	Ball Plunger	X	X	X	X
11	48092	Knob, Speed Adjustment Lever	X	X	X	X
12	*	Nut, 5/16-18 Elastic Stop	X	X	X	X
13	45141	Operator Presence, Hand Grip - RH	X	X	X	X
14	48312	Bushing, Control Rod	X	X	X	X
15	45417	Operator Presence Hand Grip & Rod - L.H. (For 16")	X	X		
15	45142	Operator Presence Hand Grip & Rod - L.H. (For 20")	X	X	X	X
16	48326	Grip, Cutter Deck Engage	X	X	X	X
17	*	Bolt, Hex Hd., 3/8-16 x 1-3/4	X	X	X	X
18	46090	Blade Clutch Lever Assy. (Includes grip)	X	X	X	X
19	04041-10	Flat Washer, 3/8 x 2 x 16 ga.	X	X	X	X
20	46076	Rod, Belt Clutch - Cutter	X	X	X	X
21	*	Carriage Bolt, 5/16-18 x 2-1/2, Rd. Hd. Sq. Nk.	X	X	X	X
22	48159	Grip, Handle	X	X	X	X
23	*	Hex Nut, 5/16-18, Elastic Stop	X	X	X	X
24	48324-01	Grip, Neutral Latch - RH	X	X	X	X
24	48324-02	Grip, Neutral Latch - LH	X	X	X	X
25	46083-01	Neutral Latch - RH (Includes grip)	X	X	X	X
25A	46083-02	Neutral Latch - LH (Includes grip)	X	X	X	X
26	04032-01	Curved Spring Washer	X	X	X	X
27	*	Flat Washer, 5/16	X	X	X	X
28	*	Bolt, Hex Hd., 5/16-18 x 2	X	X	X	X
29	48492	Grip, Steering Control	X	X	X	X
30	46333	Steering Control Lever - RH (Includes grip)	X	X	X	X
30A	46334	Steering Control Lever - LH (Includes grip)	X	X	X	X
31	04026-01	Hex Nut, 9/16-18 Spring Steel	X	X	X	X
32	48313	Spring, Grip Return	X	X	X	X
33	48021	Switch, Interlock (gold colored)	X	X	X	X
34	*	Bolt, Hex Hd., 1/4-20 x 2	X	X	X	X
35	*	Hex Nut, 1/4-20 Elastic Stop	X	X	X	X
36	*	Flat Washer, 3/8 (.406 x .812 x .065)	X	X	X	X
37	*	Hex Nut, 3/8-16 Elastic Stop	X	X	X	X
38	48050	Spring, Compression	X	X	X	X
39	*	Flat Washer, 25/64 x 15/16 x 12 ga.	X	X	X	X
40	*	Hex Nut, 3/8-16 Elastic Stop	X	X	X	X
41	*	Bolt, Hex Hd., 3/8-16 x 1	X	X	X	X
42	48017-02	Key, Ignition	X	X	X	X
43	48017-04	Hex Nut, 5/8-32	X	X	X	X
44	48017-03	Lockwasher, 5/8 Internal Tooth	X	X	X	X
45	48609	Switch, Ignition	X	X	X	
45	48017	Switch, Ignition				X
46	*	Bolt, Hex Hd., 1/4-20 x 1/2	X	X	X	X
47	*	Hex Nut, #10-32	X	X	X	X
48	*	Lockwasher, #10 External Tooth	X	X	X	X
NS	48610	Wire Harness	X	X	X	
NS	48611	Wire Harness				X
NS	48527	Wire Harness Adapter - Kawasaki	X			
50	*	Machine Screw, #10-32 x 1/2 Phillips	X	X	X	X
51	46294	Control Rod, Steering	X	X	X	X
52	04050-01	Retaining Ring, 5/8 Ext. - "E"	X	X	X	X

\* Common hardware which should be purchased locally. All bolts grade 5 plated, all other fasteners zinc plate.

HANDLE ASSEMBLY CONTINUED ON NEXT PAGE



## HANDLE ASSEMBLY CONT'D

Ref. Part No.	Part Number	Description	14KA	14KH	18KH	20KHE
53	43166	Jackshaft, Speed Control (For 16")	X	X		
53	43155	Jackshaft, Speed Control (For 20")	X	X	X	X
54	04063-13	Key, 1/8 x 1/2 Woodruff #3	X	X	X	X
55	*	Setscrew, Hex Socket Knurled Cup Pt., 1/4-28 x 1/4	X	X	X	X
56	46335	Cam, Speed Control (Includes setscrew)	X	X	X	X
57	43157	Swivel Joint, Steering Rod	X	X	X	X
58	48100-04	Bushing	X	X	X	X
59	46336	Pivot, Pump Control Shaft (Includes bushings and grease fitting)	X	X	X	X
60	*	Bolt, Hex Hd., 5/16-18 x 1	X	X	X	X
61	04001-69	Bolt, Hex Hd., 5/16-18 x 1-3/4 Full Thread	X	X	X	X
62	48409	Bearing, Speed Control	X	X	X	X
63	43161	Spacer, Speed Control Bearing	X	X	X	X
64	42730	Bar, Speed Control Adjustment	X	X	X	X
65	*	Lockwasher, 5/16	X	X	X	X
66	*	Hex Nut, 5/16-18	X	X	X	X
67	*	Bolt, Hex Hd., 5/16-18 x 1 1/4	X	X	X	X
68	04065-05	Drive Pin, 5/32 x 7/8 Type U	X	X	X	X
69	48494-02	Spring, Speed Control	X	X	X	X
70	45292	Handle, Neutral Adjustment	X	X	X	X
71	45271	Bellcrank, LH Control	X	X	X	X
71A	45272	Bellcrank, RH Control	X	X	X	X
72	48051	Spring, Neutral Return	X	X	X	X
73	48224	Bearing, Neutral Return	X	X	X	X
74	*	Bolt, Hex Hd., 3/8-16 x 3/4	X	X	X	X
75	48114-05	Grease Fitting, Straight 1/4-28	X	X	X	X
76	45274	Neutral Cam, RH (Includes grease fitting)	X	X	X	X
76A	46338	Neutral Cam, LH (Includes grease fitting)	X	X	X	X
77	*	Hex Nut, 1/4-20	X	X	X	X
78	*	Lockwasher, 1/4	X	X	X	X
79	45094	Bellcrank Pivot	X	X	X	X
80	*	Bolt, Hex Hd., 1/4-20 x 1	X	X	X	X
81	44064	Rod, Blade Clutch - Lower	X	X	X	X
82	45277	Bellcrank, Cutter Engage (Includes grease fitting)	X	X	X	X
83	45295	Shaft, LH Pump Control	X	X	X	X
84	*	Retaining Ring, 1/2" Ext. - "E"	X	X	X	X
85	48091	Choke Control			X	X
86	48026	Switch, Neutral	X	X	X	X
87	48028-01	Cable Tie	X	X	X	X
88	48059-01	Clamp, Fuel Hose	X	X	X	X
89	48179-01	Fuel Hose, Short 7/32 ID x 3-1/2 (KA only)	X			
90	48057-02	Fuel Filter	X			
91	48058-05	Fuel Hose, 1/4 ID x 20	X			
91	48058-10	Fuel Hose, 1/4" x 10"		X		
91	48058-02	Fuel Hose, 1/4 ID x 14-1/8 (KH only)			X	X
92	48308	Valve, Fuel Shut-off	X	X	X	X
93	48309	Bushing	X	X	X	X
94	48205	Pad, Rubber - Fuel Tank - Lower	X	X	X	X
95	*	Machine Screw, 1/4-20 x 2 Round Hd. Slotted	X	X	X	X
96	42369	Strap, Fuel Tank	X	X	X	X
97	48292	Pad, Rubber - Fuel Tank - Upper	X	X	X	X
98	48311	Fuel Tank Cap	X	X	X	X
99	46174	Fuel Tank Assembly (Includes items 92, 93)	X	X	X	X
100	46295	Rod, Traction Control	X	X	X	X
101	45279	Bellcrank, Speed Control	X	X	X	X
102	*	Carriage Bolt, 5/16-18 x 1 Rd. Hd. Sq. Nk.	X	X	X	X
103	46430	Oil Reservoir (For 16") Includes Decal	X	X		
103	46429	Oil Reservoir (For 20") Includes Decal	X	X	X	X
104	48325	Cap, Oil Reservoir	X	X	X	X
105	48394	Throttle Control	X	X		
105	48266	Throttle Control			X	X
106	43032	Swivel Joint, Speed Control Rod	X	X	X	X

\* Common hardware which should be purchased locally. All bolts grade 5 plated, all other fasteners zinc plate.

## ELECTRIC START ELECTRICAL SYSTEM

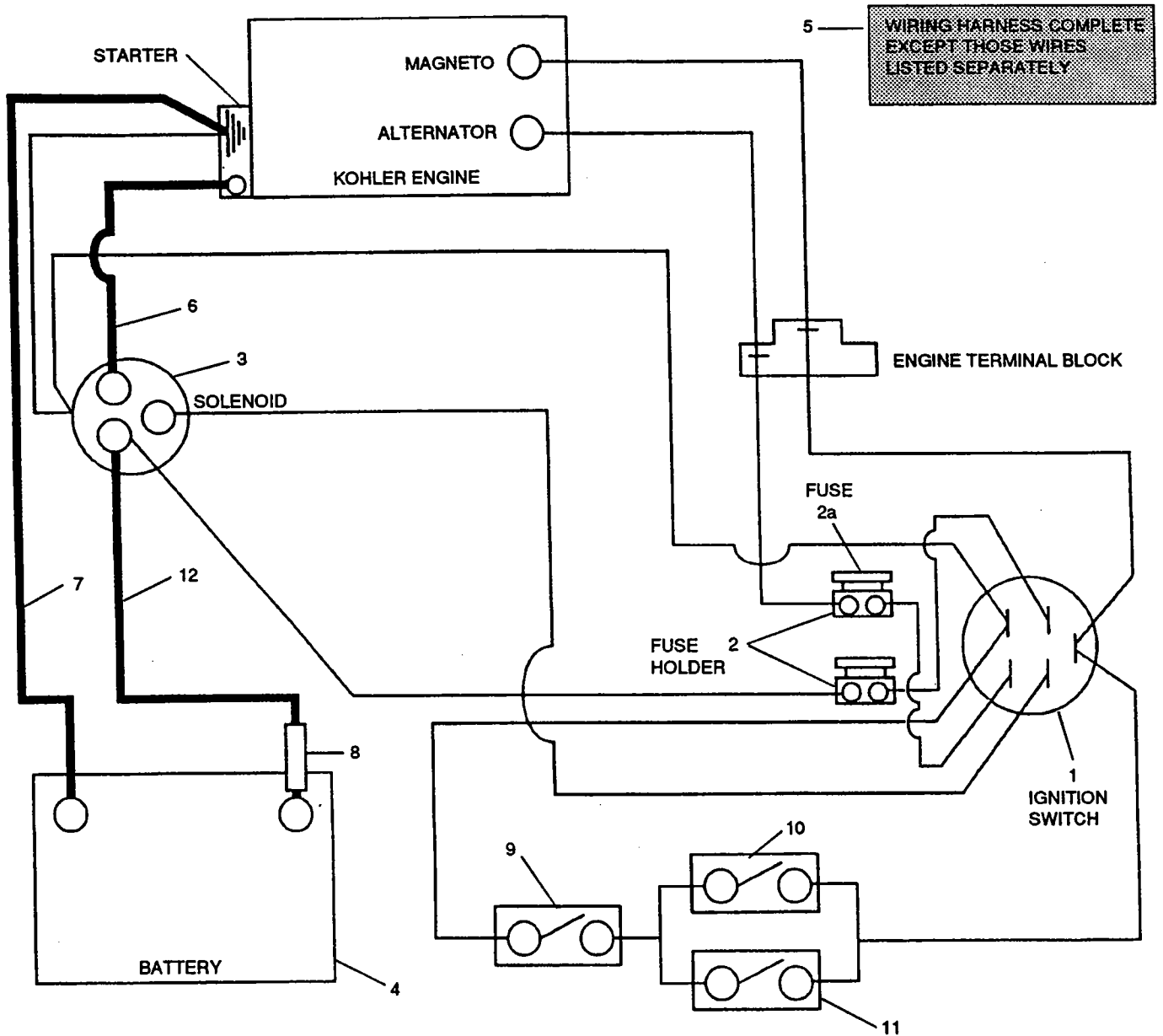

Ref. No.	Part Number	Description	SWZ 20KHE
1	48017	Key Switch	X
2	48297	Fuse Holder	X
2a	48298	Fuse 20 Amps	X
3	48016	Solenoid	X
4	48015	Battery may be purchased locally (U9-LM)	X
5	48611	Wiring Harness Complete	X
6	48029-03	Battery Cable - 13-3/4" Red	X
7	48029-10	Battery Cable - 20" Black	X
8	43126	Rubber Boot	X
9	48021	Switch, Operator Presence Interlock N.C.	X
10	48305	Switch, Cutter Drive Interlock N.C.	X
11	48026	Switch, Neutral Interlock N.C.	X
12	48029-02	Battery Cable - 31.5" Red	X

## WIRING DIAGRAM FOR MANUAL START

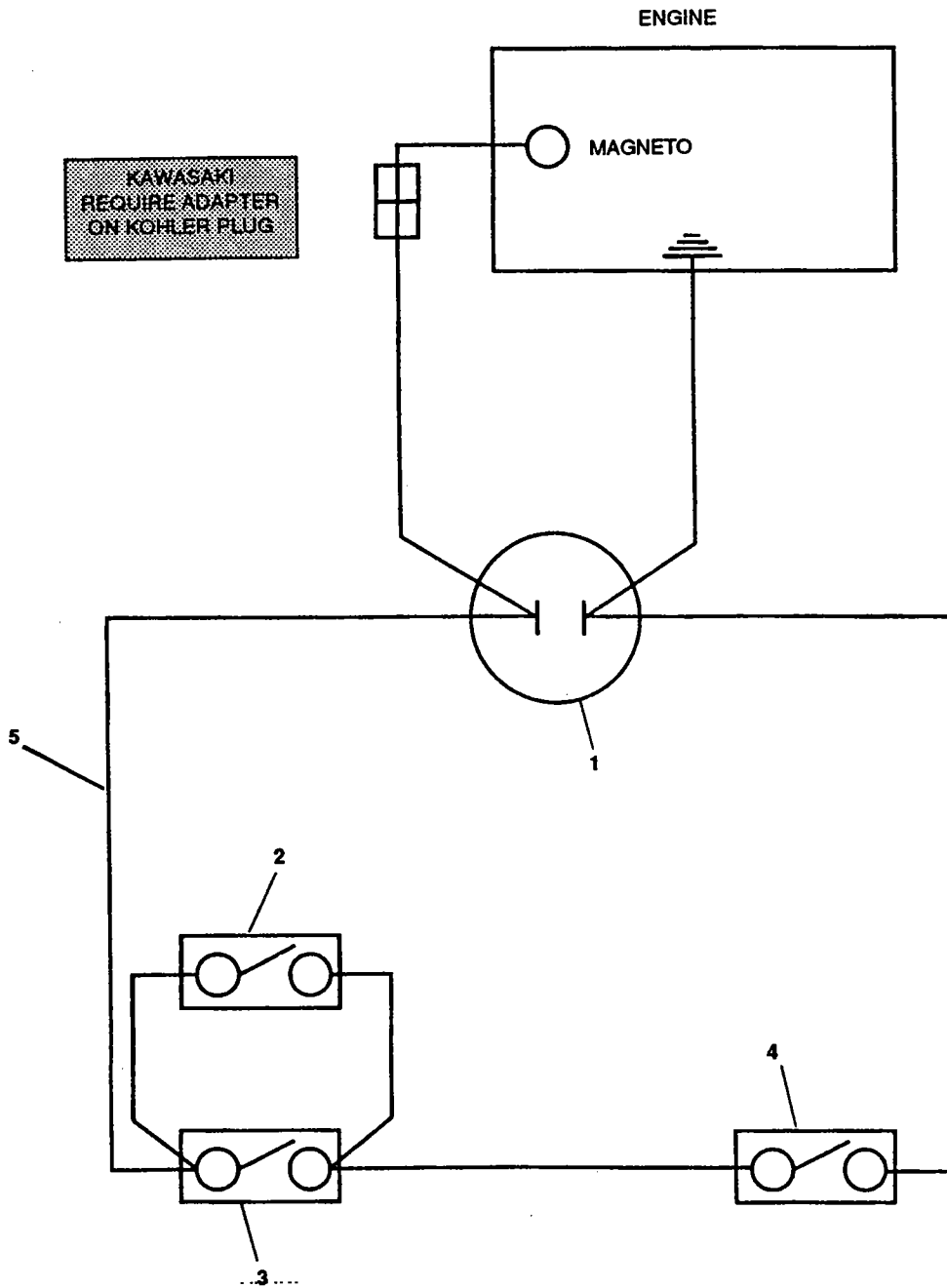

Ref. No.	Part Number	Description
1	48609	Switch, Ignition
2	48026	Switch, Neutral Interlock, N.C.
3	48305	Switch, Cutter Drive Interlock, N.C.
4	48021	Switch, Operator Presence Interlock, N.C.
5	48610	Wire Harness

**WARNING**

If incorrectly used, this machine can cause severe injury. Those who use and maintain the machine should be trained in its proper use, warned of its dangers, and should read the entire manual before attempting to set up, operate, adjust or service

**LIMITED WARRANTY-COMMERCIAL EQUIPMENT**

Any part of the Scag commercial mower manufactured by Scag and found, in the reasonable judgment of Scag, to be defective in material or workmanship, will be repaired or replaced by an Authorized Scag Service Dealer without charge for parts and labor.

The Scag mower including any defective part must be returned to an Authorized Scag Service Dealer within the warranty period. The expense of delivering the mower to the dealer for warranty work and the expense of returning it back to the owner after repair or replacement will be paid for by the owner. Scag's responsibility in respect to claims is limited to making the required repairs or replacements, and no claim of breach of warranty shall be cause for cancellation or rescission of the contract of sale of any Scag mower. Proof of purchase will be required by the dealer to substantiate any warranty claim. All warranty work must be performed by an Authorized Scag Service Dealer.

This warranty is limited to one year from the date of original retail purchase for any Scag mower that is used for commercial purposes, or any other income-producing purpose (90 days for rental use). Traction drive system will be warranted for two full years from date of original retail purchase against defects in material or workmanship excluding hoses, lines and drive belts. Belts and tires are warranted for 90 days against defects in workmanship or materials.

This warranty does not cover any mower that has been subject to misuse, neglect, negligence, or accident, or that has been operated in any way contrary to the operating instructions as specified in the Technical Manual. The warranty does not apply to any damage to the mower that is the result of improper maintenance, or to any mower or parts that have not been assembled or installed as specified in the Technical Manual.

The warranty does not cover any mower that has been altered or modified. In addition, the warranty does not extend to repairs made necessary by normal wear, or by the use of parts or accessories which, in the reasonable judgment of Scag, are either incompatible with the Scag mower or adversely affect its operation, performance or durability. This warranty does not cover engines and electric starters, which are warranted separately by their manufacturer.

Scag Power Equipment reserves the right to change or improve the design of any mower without assuming any obligation to modify any mower previously manufactured.

All other implied warranties are limited in duration to the one (1) year warranty period or ninety (90) days for mowers used for rental purpose. Accordingly, any such implied warranties including merchantability, fitness for a particular purpose, or otherwise, are disclaimed in their entirety after the expiration of the appropriate one-year or ninety day warranty period. Scag's obligation under this warranty is strictly and exclusively limited to the repair or replacement of defective parts and Scag does not assume or authorize anyone to assume for them any other obligation. Some states do not allow limitations on how long an implied warranty lasts, so the above limitation may not apply to you.

Scag assumes no responsibility for incidental, consequential or other damages including, but not limited to, expense for gasoline, expense of delivering the mower to an Authorized Scag Service Dealer and expense of returning it back to the owner, mechanic's travel time, telephone or telegram charges, rental of a like product during the time warranty repairs are being performed, travel, loss or damage to personal property, loss of revenue, loss of use of the mower, loss of time or inconvenience. Some states do not allow the exclusion or limitation of incidental or consequential damages. So the above limitation or exclusion may not apply to you.

This warranty gives you specific legal rights, and you may also have other rights which vary from state to state.

**PLEASE BE CAREFUL**

1. Keep all shields in place, especially grass discharge.
2. Stop machine and remove spark plug wire to adjust or service.
3. When mechanism becomes clogged, stop engine before cleaning.
4. Keep hands, feet and clothing away from power-drive parts.
5. Keep off implement unless seat or platform is provided.
6. Keep others off.

**FAILURE TO FOLLOW CAUTIOUS OPERATING PRACTICES MAY RESULT IN SERIOUS BODILY INJURY. BESIDES, WE WOULD LIKE YOU TO CONTINUE TO ENJOY AND PROFIT BY USING OUR PRODUCTS.**

**OWNER REFERENCE**

MODEL NUMBER \_\_\_\_\_

SERIAL NUMBER \_\_\_\_\_

ENGINE MODEL \_\_\_\_\_

SERIAL NUMBER \_\_\_\_\_