

SCAG
POWER EQUIPMENT

Model
SSZ-42
SSZ-48

From S/N 40000 To 49999

ILLUSTRATED PARTS LIST

PART NO. 06004

TABLE OF CONTENTS

Deck Assembly — 42"	1A-1B
Deck Assembly — 48".....	2-3
Sheet Metal Components	4-5
Hydraulic Components	6-7
Traction Drive Components.....	8-9
Brake and Steering Controls.....	10-11
Instrument Panel and Electrical Components.....	12-13
Electrical Wiring Diagrams.....	14-15
Replacement Decals.....	16-17

42" CUTTER DECK

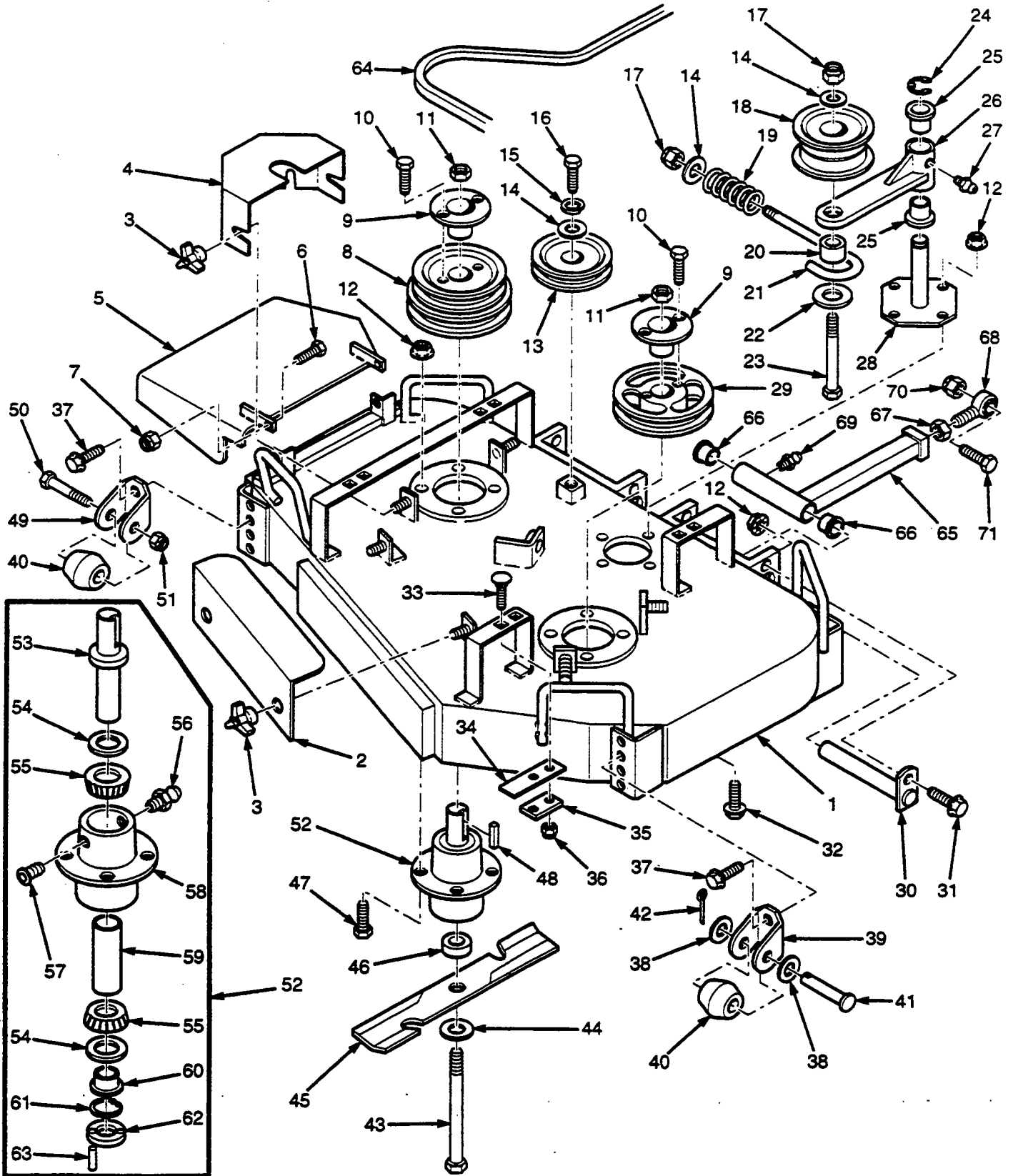

42" CUTTER DECK

Ref. Part No. Number	Description	Ref. Part No. Number	Description		
1	45570	Cutter Deck	37	04017-27	Serr. Flange HH cpscr, 3/8-16 x 1"
2	421058	Belt Cover, Front	38	04040-09	Flat Washer, 5/8-.656 x 1.312 x .095"
3	04029-03	Wing Nut 3/8-16	39	421478	Bracket, Anti-Scalp Wheel - LH Front
4	421452	Belt Cover	40	48584	Wheel, Anti-Scalp
5	45331	Discharge Chute	41	04064-06	Pin, Clevis 5/8 x 4.0"
6	"	Bolt, Hex Head 5/16-18 x 1"	42	04061-04	Pin, Cotter 5/32 x 1.50"
7	"	Nut, Hex Elastic Stop 5/16 -18	43	04001-41	Bolt, Hex Head 5/8-11 x 9.50"
8	48940	Pulley, Double Groove	44	04040-10	Flat Washer, 5/8-.688 x 1.750 x .134"
9	48141	Tapered Hub, 1" Bore	45	48111	Cutter Blade, 21" Standard
10	"	Bolt, Hex Head 1/4-20 x .75"	45	45304	Cutter Blade, 21" Hi-Lift
11	"	Nut, Hex 5/8-11	46	43279	Spacer, Spindle Bottom
12	04019-03	Nut, Serr. Flange 5/16-18	47	"	Bolt, Hex Head 5/16-18 x 1.25"
13	48269	Pulley, Idler	48	04063-08	Key, 1/4 x 1/4 x 2"
14	04041-07	Flat Washer, 3/8-.391 x .938 x .105"	49	42882	Bracket, Anti-Scalp Wheel
15	04030-04	Lockwasher, 3/8"	50	04001-79	Bolt, Hex Head 5/8-11 x 4.50"
16	"	Bolt, Hex Head 3/8-16 x 2.25"	51	04021-13	Nut, Elastic Stop 5/8-11
17	"	Nut, Hex Elastic Stop 3/8-16	52	46400	Spindle Assembly, Tapered Bearing
18	48550	Pulley, Idler	53	45391	Spindle Shaft, Tapered Bearing
19	48807	Spring, Cutter Deck	54	48681	Seal
20	43282	Spacer	55	48668	Tapered Bearing W/Race
21	44101	J-Rod	56	48114-02	Grease Fitting, STR. 5/16 Serr.
22	04041-12	Flat Washer, 3/8-.375 x 1.500 x .060	57	48677	Relief Fitting, Cutter Spindle
23	"	Bolt, Hex Head 3/8-16 x 4.50"	58	41008	Spindle Housing, Tapered Bearing
24	04050-05	Retaining Ring, 1 1/8 Ext. Basic	59	43218	Sleeve, Cutter Spindle
25	48100-02	Bushing, Super oilube-1 1/8 ID.	60	43217	Spindle Bushing
26	45521	Idler Arm (Includes Items 25 and 27)	61	04050-04	Retaining Ring, 1" Ext. Inverted
27	48114-04	Grease Fitting, Self Tap 1/4-28	62	43201	Spacer, Cutter Blade
28	45329	Idler Pivot Support	63	04060-05	Roll Pin, 1/8 x 1/2"
29	48753	Pulley, LH Spindle	64	481003	Belt, Cutter Deck Drive
30	45332	Push Rod Shaft	65	46626	Push Rod Assembly (includes 66 Thru 69)
31	04017-17	Serr. Flange HH cpscr, 5/16-18 x 1"	66	48100-06	Bushing
32	04017-16	Serr Flange HH cpscr, 5/16-18 x .75"	67	04020-16	Nut, 5/8-18 UNF
33	"	Bolt, Carriage 1/4-20 x 1"	68	48763	Rod End
34	48817	Rubber Pad, Deck Bumper	69	48114-04	Grease Fitting - Self Thrd.
35	421232	Backup Plate, Deck Pad	70	"	Hex Nut, 5/16-11 Elastic Stop
36	04021-08	Nut, Elastic Stop 1/4-20	71	"	Hex Head Bolt, 5/8-11 x 3"

* Common hardware which should be purchased locally. All bolts grade 5 plated, all other fasteners zinc plated.

48" CUTTER DECK

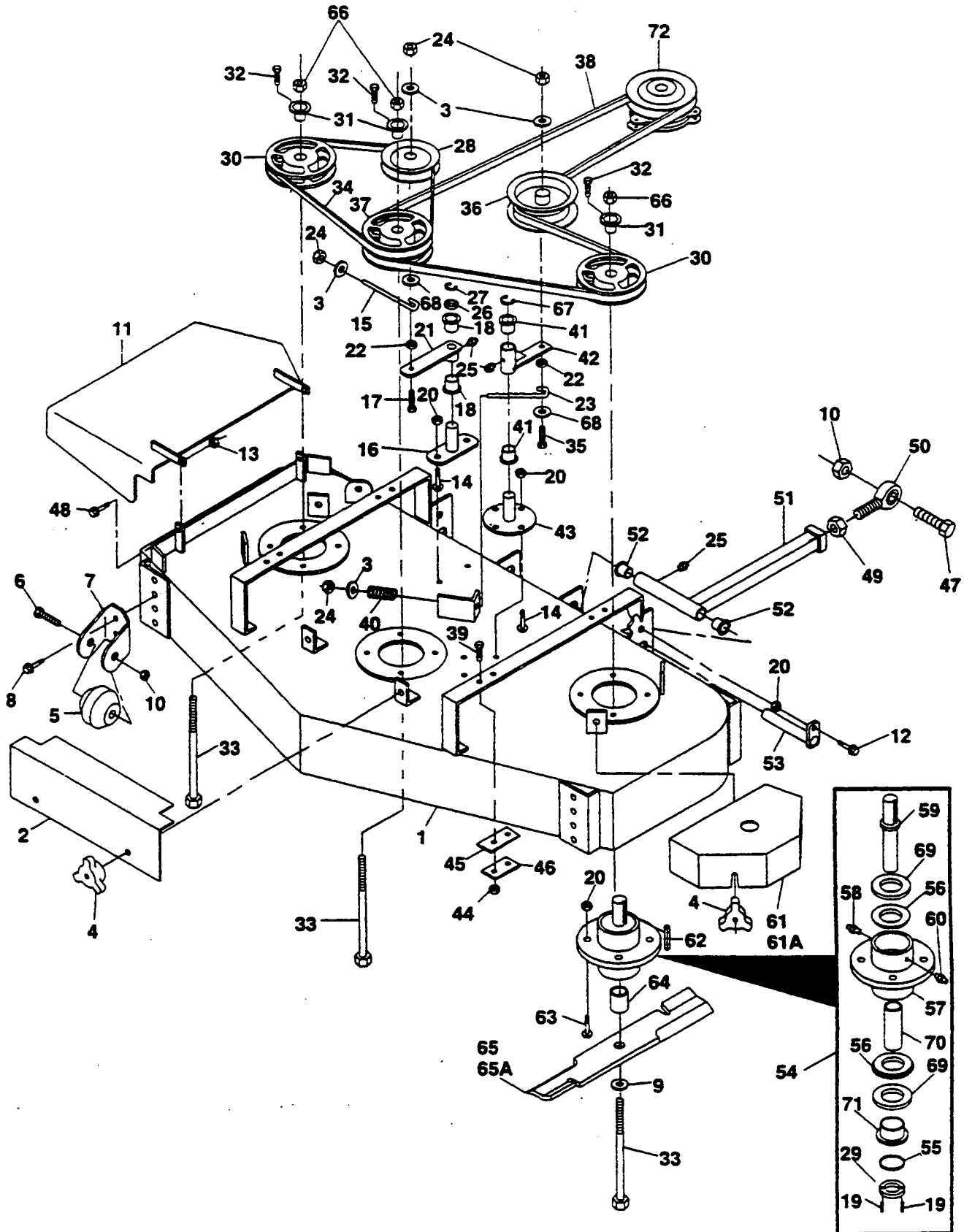

CUTTER DECK

Ref. No.	Part Number	Description	Ref. No.	Part Number	Description
1	46478	Cutter Deck (Includes decals)	37	48923	Pulley, Double
2	421058	Belt Cover, Front	38	48799	Belt, Blade Drive
3	04041-07	Flatwasher, 3/8" Special	39	.	Carriage Head Bolt, 1/4-20 x 1"
4	04029-03	Wing Nut, 3/8-16	40	48807	Spring, Idler Tension
5	48584	Anti-Scalp Wheel	41	48100-02	Bushing
6	.	Hex Head Bolt, 5/8-11 x 4-1/2"	42	46600	Idler Arm (Includes bushings & grease fitting)
7	42882	Anti-Scalp Wheel Bracket	43	45329	Idler Pivot Base
8	04017-27	Cap Screw, 3/8-16 x 1" Serrated Flange Hex Head	44	.	Elastic Stop Nut, 1/4-20
9	04040-10	Flatwasher 5/8" (.688 x 1.75 x .134)	45	48817	Rubber Pad
10	.	Hex Nut, 5/8-11 Elastic Stop	46	421232	Back-up Plate
11	45331	Discharge Chute	47	.	Hex Head Bolt, 5/8-11 x 3"
12	04017-17	Cap Screw, 5/16-18 x 1" Serrated Flange Hex Head	48	.	Hex Head Bolt, 5/16-18 x 1"
13	.	Hex Nut, 5/16-18 Elastic Stop	49	.	Hex Nut, 5/8-18 UNF
14	04017-16	Cap Screw, 5/16-18 x 3/4" Serrated Flange Hex Head	50	48763	Rod End
15	44078	"J" Rod	51	46460	Push Arm (Includes 25,49,50 & 52)
16	45037	Idler Pivot Base	52	48100-06	Bushing
17	.	Hex Head Bolt, 3/8-16 x 2-1/4"	53	45332	Push Arm Shaft
18	48100-05	Bushing	54	46400	Cutter Spindle Assembly (Complete, Tapered)
19	.	Roll Pin 1/8 x 1/2"	55	04050-04	Retaining Ring, 1" External, Inverted
20	04019-03	Nut, 5/16-18 Serrated Flange Hex Head	56	48668	Bearing & Cup, Tapered Spindle
21	46081	Idler Arm, (Includes bushings & grease fitting)	57	41008	Spindle Housing, Tapered Spindle
22	43077	Spacer	58	48114-02	Grease Fitting
23	43028	"J" Rod	59	45391	Spindle Shaft, Tapered Spindle
24	.	Hex Nut, 3/8-16 Elastic Stop	60	48667	Relief Fitting, Tapered Spindle
25	48114-04	Grease Fitting	61	421219	Belt Cover - RH
26	04041-08	Flatwasher 3/4"	61A	421218	Belt Cover - LH
26A	04041-08S	Flatwasher, 3/4" Special	62	04063-08	Key, 1/4 x 1/4 x 2"
27	04050-02	Retaining Ring, 3/4" External "E"	63	04017-18	Cap Screw, 5/16-18 x 1-1/4" Serrated Flange Hex Head
28	48181	Pulley, Idler	64	43279	Spacer-Tapered Spindle
29	43201	1/4" Blade Spacer	65	48110	Cutter Blade, 16-1/2" Standard
30	48924	Pulley	65A	48184	Cutter Blade, 16-1/2" High Lift
31	48141	Tapered Hub	66	.	Hex Nut, 5/8-11
32	.	Hex Head Bolt, 1/4-20 x 3/4"	67	04050-05	Retaining Ring 1-1/8" External "E"
33	04001-41	Hex Head Bolt, 5/8-11 x 9-1/2"	68	04041-12	Flatwasher, 3/8" (3/8 x 1.5 x .06)
34	48087	Belt, RH Blade Drive	69	48681	Seal, Tapered Cutter Spindle
35	.	Hex Head Bolt, 3/8-16 x 4"	70	43218	Spacer, Tapered Spindle
36	48550	Pulley, Idler - Cutter Engagement	71	43217	Bushing, Tapered Spindle
			72	48786	Electric Clutch

* Common hardware which should be purchased locally. All bolts Grade 5 plated, all other fasteners zinc plated.

SHEET METAL COMPONENTS

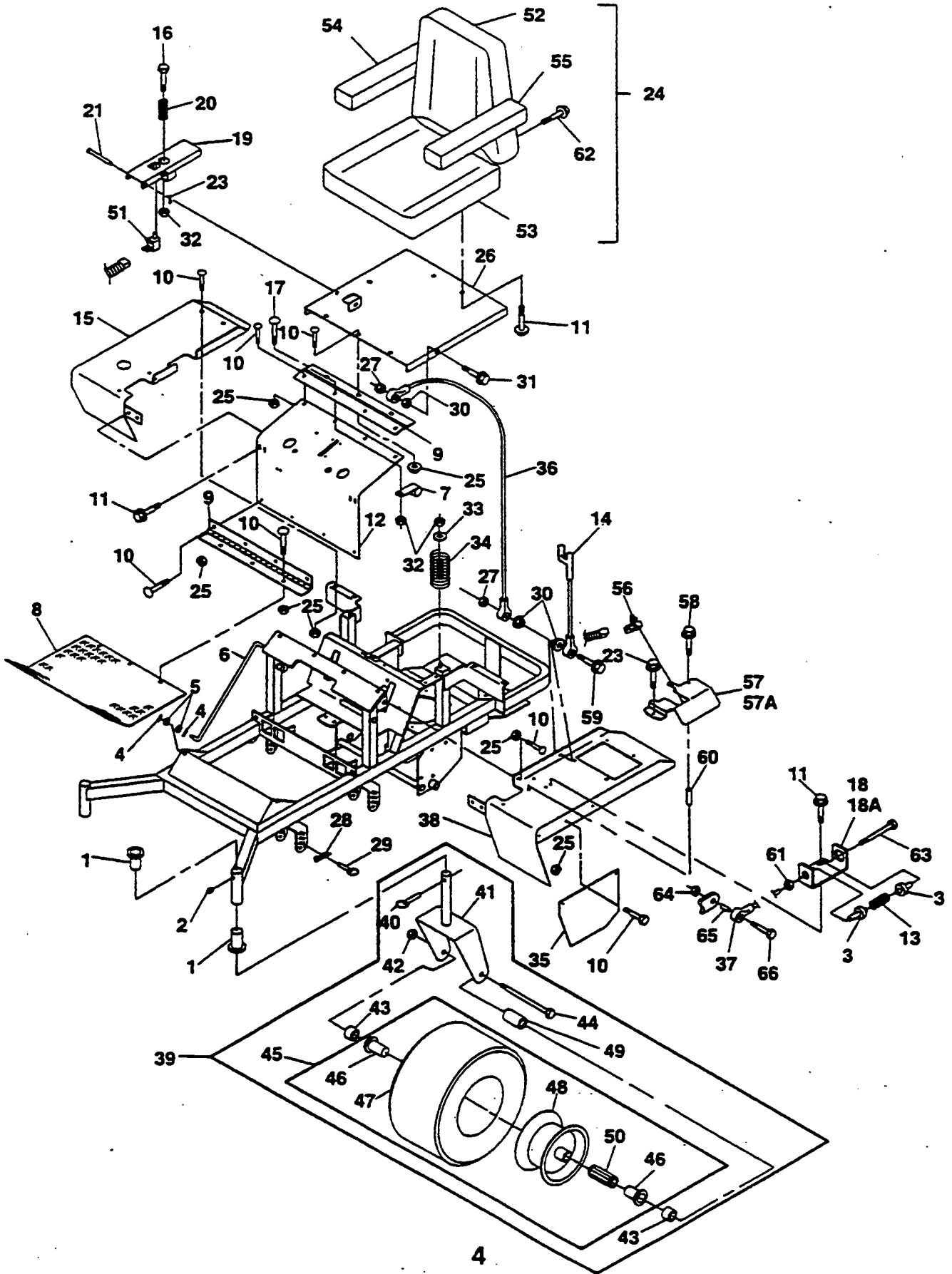

SHEET METAL COMPONENTS

Ref. No.	Part Number	Description	Ref. No.	Part Number	Description
1	48100-08	Bushing	34	48686	Seat Spring
2	48114-04	Grease Fitting	35	421198	Fender Panel, LH
3	43257	Bushing, Spring Keeper	36	48566	Cable, Seat Stop
4	04062-02	Hair Pin, .08" Diameter	37	48464	Ball Joint, Neutral
5	04041-07	Flatwasher, 3/8" Special	38	45479	Fender - LH
6	44062	Rod, Foot Plate Latch	39	46392	Caster Wheel Yoke Assembly, Complete
7	48030-06	Clamp	40	04066-01	Quick Pin
8	42764	Foot Plate	41	45325	Caster Wheel Yoke
9	48547	Hinge	42	.	Elastic Stop Nut, 1/2-13
10	.	Carriage Bolt, 5/16-18 x 3/4"	43	43041	Spacer
11	04017-16	Cap Screw, 5/16-18 x 3/4" Serrated Flange Hex Head	44	.	Hex Head Bolt, 1/2-13 x 6-1/2"
12	421251	Kick Plate	45	48537	Wheel Assembly, Complete
13	48746	Neutral Return Spring	46	48006-07	Retainer
14	48994	Cable, Seat Stop	47	48537-02	Tire Only
15	46505	Fender Assembly, RH (with decal)	48	48537-03	Rim Only
16	.	Hex Head Bolt, 5/16-18 x 3-3/4"	49	43022	Sleeve
17	.	Carriage Bolt, 5/16-18 x 1"	50	48006-06	Roller Bearing
18	421411	Retainer, Neutral Spring, LH	51	48717	Seat Switch
18A	421412	Retainer, Neutral Spring, RH	52	48704-02	Seat Back Cushion
19	45405	Seat Switch Bracket	53	48704-03	Seat Bottom Cushion Assembly
20	48463	Spring	54	48704-04	Arm Pad, RH
21	04064-04	Clevis Pin	55	48704-05	Arm Pad, LH
22	04017-15	Cap Screw, 5/16-18 x 1/2" Serrated Flange Hex Head	56	48522	Neutral Interlock Switch
23	04062-02	Hair Pin Cotter	57	421253	Neutral Lock Bracket, RH
24	48831	Seat Assembly	57A	421252	Neutral Lock Bracket, LH
25	04019-03	Nut, 5/16-18 Serrated Flange Hex Head	58	04017-24	Cap Screw, 5/16-18 x 2-3/4" Serrated Flange Hex Head
26	45404	Seat Base	59	04017-08	Cap Screw, 1/4-20 x 1-1/2" Serrated Flange Hex Head
27	.	Hex Nut, 1/4-20 Elastic Stop	60	43258	Spacer, Neutral Lock Bracket
28	04062-03	Hair Pin	61	.	Hex Nut, 3/8-24 UNF
29	04067-03	Ring Pin	62	48704-06	Hex Head Screw w/Washer, 1/4-20 x 3/4"
30	04019-02	Nut, 1/4-20 Serrated Flange Hex Head	63	04001-99	Hex Head Bolt, 3/8-24 x 6-1/2", UNF
31	04017-06	Cap Screw, 1/4-20 x 1" Serrated Flange Hex Head	64	.	Elastic Stop Nut, 3/8-16
32	04021-10	Elastic Stop Nut, 5/16-18	65	43240	Spacer Neutral Spring
33	.	Flatwasher, 5/16"	66	.	Hex Head Bolt, 3/8-16 x 2 1/2"

* Common hardware which should be purchased locally. All bolts Grade 5 plated, all other fasteners zinc plated.

HYDRAULIC COMPONENTS

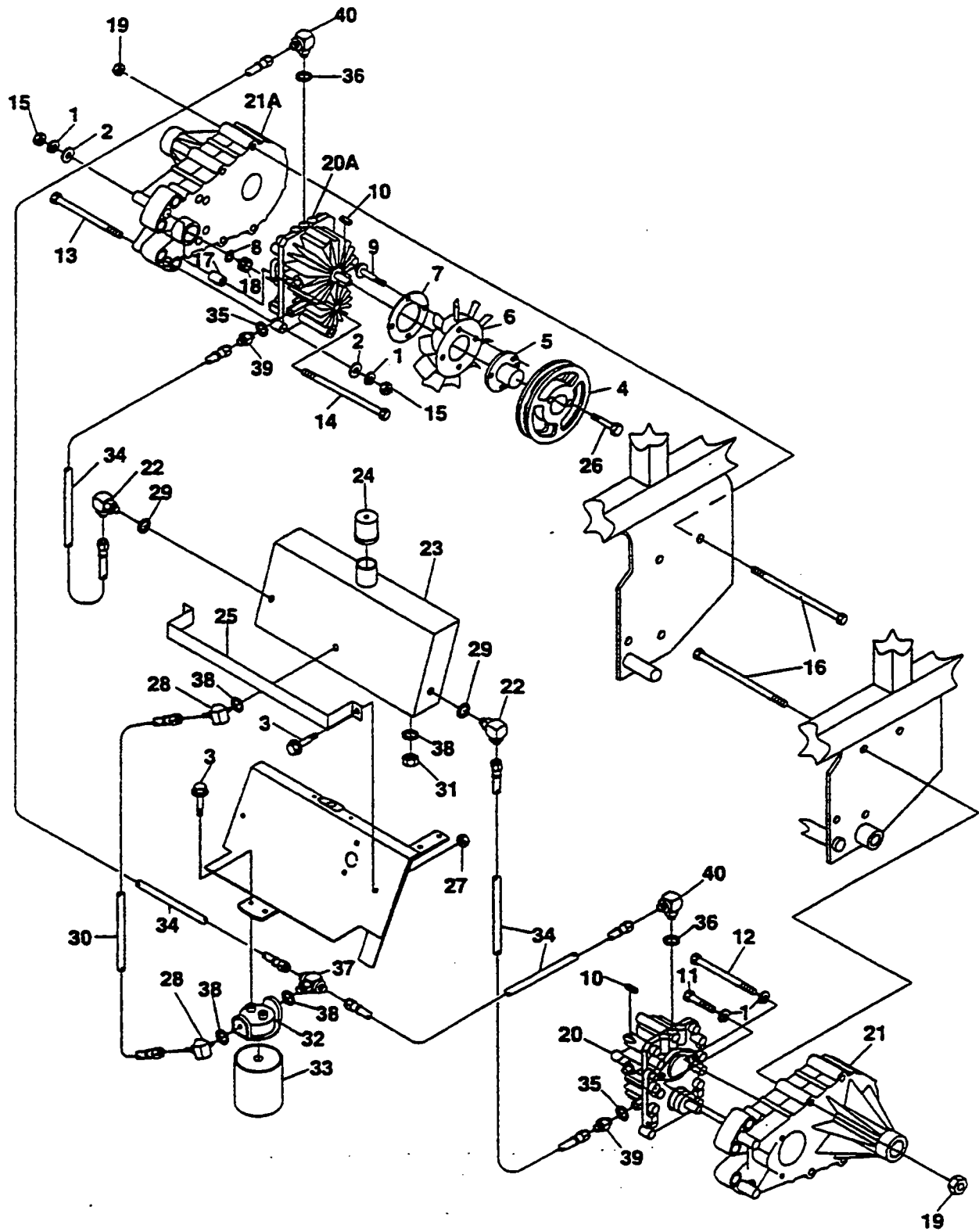

HYDRAULIC COMPONENTS

Ref. No.	Part Number	Description	Ref. No.	Part Number	Description
1	.	Lockwasher, 5/16"	22	48350-09	90 Degree Elbow, 9/16-18 JIC to 9/16 -18"O" Ring
2	.	Flatwasher, 5/16"	23	48860	Oil Tank Reservoir
3	04017-05	Cap Screw, 1/4-20 x 3/4" Serrated Flange Hex Head	24	48894	Cap, Oil Reservoir
4	48790	Pump Pulley	25	421208	Oil Reservoir Strap
5	48791	Tapered Hub, 15mm Bore	26	.	Hex Head Bolt, 1/4-20 x 1-1/4"
6	48789	Fan	27	.	Nut, 1/4-20 Elastic Stop
7	421209	Back-up Washer	28	48485-01	45 Degree Elbow, 3/4-16 JIC to 3/4-16 "O" Ring
8	04050-13	Snap Ring	29	48603-06	"O" Ring, 5/64 x 15/32 ID
9	04017-04	Cap Screw, 1/4-20 x 1/2" Serrated Flange Hex Head	30	48872	Hose Assembly, Filter Inlet
10	04063-14	Key, 5 x 5 x 25mm	31	48604-02	Plug, 3/4-16 "O" Ring
11	.	Hex Head Bolt 5/16-18 x 1-3/4"	32	48462-02	Head, Oil Filter
12	04001-96	Hex Head Bolt 5/16-18 x 4-1/2"	33	48462-01	Oil Filter, Special
13	04001-95	Hex Head Bolt 5/16-18 x 5"	34	48871	Hose Assembly
14	04001-94	Hex Head Bolt 5/16-18 x 7-1/2"	35	48603-04	"O" Ring, 3/32 x 3/4 ID
15	.	Nut, 5/16-18	36	48603-03	"O" Ring, 1/16 x 3/8 ID
16	.	Hex Head Bolt, 3/8-16 x 4"	37	48810-01	1/2", T-fitting, 3/4-16 JIC to 3/4-16 "O" Ring
17	48878	Spacer	38	48603-02	"O" Ring, 3/32 x 5/8 ID
18	48875	Gear	39	48572-02	Tube Union, 3/4-16 JIC to 7/8-14 "O" Ring
19	04019-04	Nut, 3/8-16 Serrated Flange Hex Head	40	48350-10	90 Degree Elbow, 9/16-18 JIC to 7/16-20 "O" Ring
20	48784	Pump, LH (Includes Spacers)			
20A	48785	Pump, RH (Includes Spacers)			
21	48782	Axle, LH, (Includes Brake Lever)			
21A	48783	Axle, RH, (Includes Brake Lever)			

* Common hardware which should be purchased locally. All bolts Grade 5 plated, all other fasteners zinc plated.

TRACTION DRIVE COMPONENTS

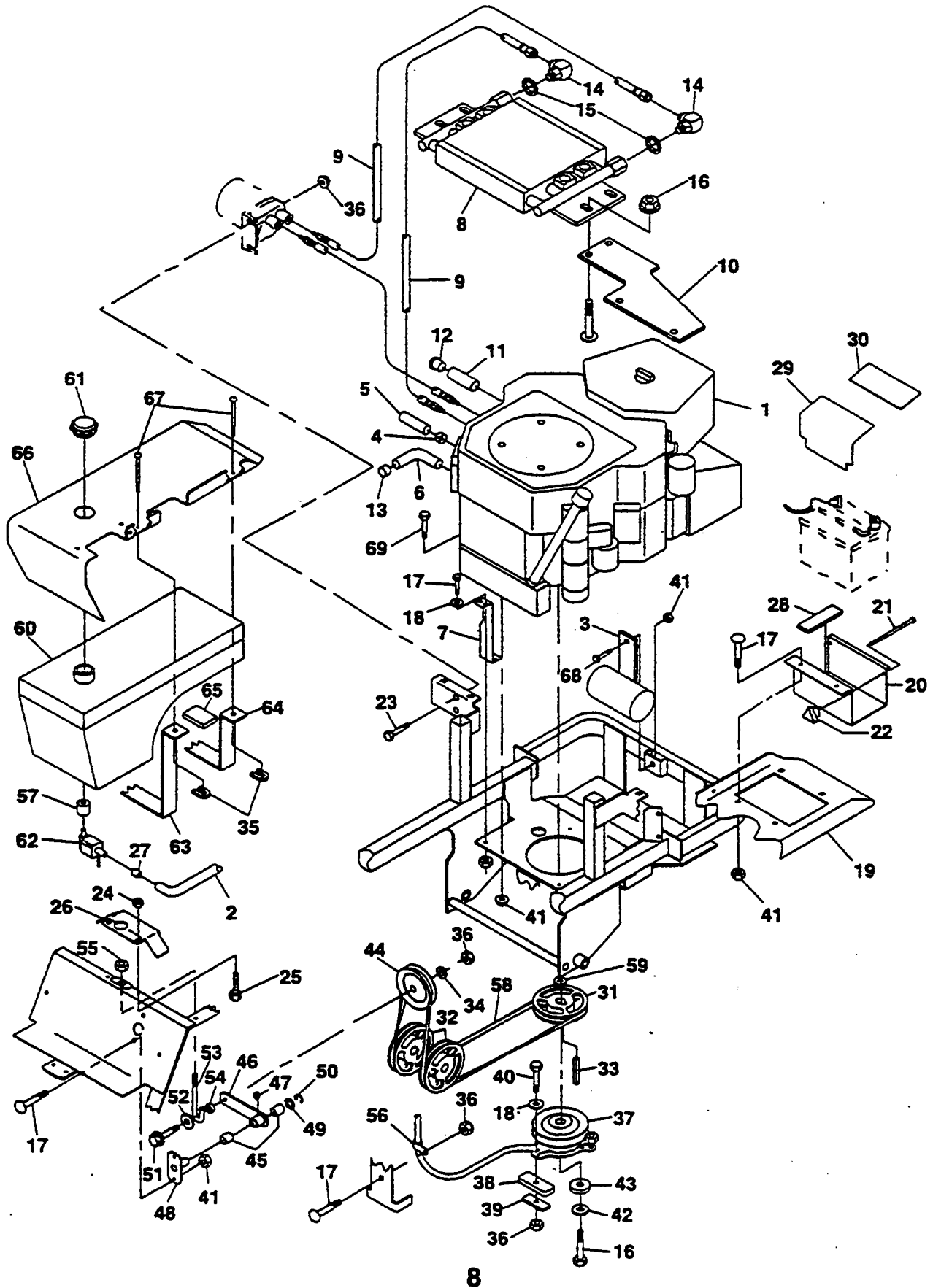

TRACTION DRIVE COMPONENTS

Ref. No.	Part Number	Description	16BV	18CV
1	48835	Engine 18 hp Kohler CV		X
1	48766	Engine 16 hp Briggs Vanguard	X	
2	48058-14	Fuel Hose, 36" Long	X	
2	48058-03	Fuel Hose, 23" Long		X
3	48899	Muffler	X	
4	48633	Muffler Clamp		X
5	48964	Tube, Exhaust		X
6	48600-01	Street Elbow	X	
7	421407	Heat Shield	X	
8	48645	Oil Cooler		X
9	48962	Hose, Oil Cooler		X
10	421386	Mounting Bracket, Oil Cooler		X
11	48402-02	Extension, 3"		X
12	48257	Pipe Cap		X
13	.	Pipe Plug, 3/8 NPT	X	
14	48963-01	90 Degree Elbow, 1/2-20 SAE to 3/4 16 "O"-Ring		X
15	48603-02	O-Ring		X
16	04001-93	Hex Head Bolt, 7/16-20 x 3"	X	
16	04001-101	Hex Head Bolt, 7/16-20 x 2-1/2"		X

Ref. No.	Part Number	Description	Ref. No.	Part Number	Description
17	.	Carriage Bolt, 5/16-18 x 3/4"	45	48100-05	Bushing
18	.	Flatwasher, 5/16"	46	46081	Idler Arm (Includes bushings and grease fittings)
19	45479	Fender, LH	47	48114-04	Grease Fitting
20	421197	Battery Box	48	45037	Idler Pivot Base
21	.	Carriage Bolt, 1/4-20 x 6"	49	04041-08	Flatwasher, 3/4"
22	04029-01	Wing Nut, 1/4-20	49A	04041-08S	Flatwasher, 3/4" Special
23	.	Carriage Bolt, 5/16-18 x 1"	50	04050-02	Retaining Ring, 3/4" external "E"
24	04019-02	Nut, 1/4-20 Serrated Flange Hex Head	51	.	Hex Head Bolt, 3/8-16 x 2-1/4"
25	.	Carriage Bolt, 1/4-20 x 3/4"	52	04041-12	Flatwasher 3/8 x 1-1/2 x .06
26	421234	Belt Guard	53	44075	"J" Bolt
27	48059-01	Fuel Hose Clamp	54	43077	Spacer
28	48661	Rubber Pad	55	.	Elastic Stop Nut, 3/8-16
29	42392	Battery Cover	56	48030-09	Clamp
30	48099	Battery Cover Pad	57	48309	Bushing, Fuel Tank Valve
31	48792	Pulley	58	48760	Belt, Pump Drive
32	48790	Pump Pulley	59	43248	Spacer, Crankshaft
33	04063-06	Key, 1/4 x 1/4 x 1-1/2"	60	48651	Fuel Tank (Includes Shut-off Valve)
34	04041-07	Flatwasher, 3/8" Special	61	48311	Fuel Tank Cap
35	04110-01	U-Nut, 1/4-20	62	48568	Fuel Shut-off Valve
36	04021-10	Elastic Stop Nut, 5/16-18	63	42944	Fuel Tank Strap, Long
37	48786	Electric Clutch	64	42945	Fuel Tank Strap, Short
38	48814	Rubber Pad, Clutch Stop	65	48657	Rubber Pad
39	421215	Backing Plate	66	46505	Fender Assembly, RH (with decal)
40	.	Hex Head Bolt, 5/16-18 x 1-1/4"	67	.	Machine Screw, 1/4-20 x 2"
41	04019-03	Nut, 5/16-18 Serrated Flange Hex Head	68	04017-16	Capscrew, 5/16-18 x 3/4" Serrated Flange Hex Head
42	.	Lockwasher, 7/16"	69	04017-19	Capscrew, 5/16-18 x 1-1/2"
43	04041-18	Flatwasher, 7/16" Special			
44	48181	Idler Pulley			

* Common hardware which should be purchased locally. All bolts Grade 5 plated, all other fasteners zinc plated.

BRAKE AND STEERING CONTROLS

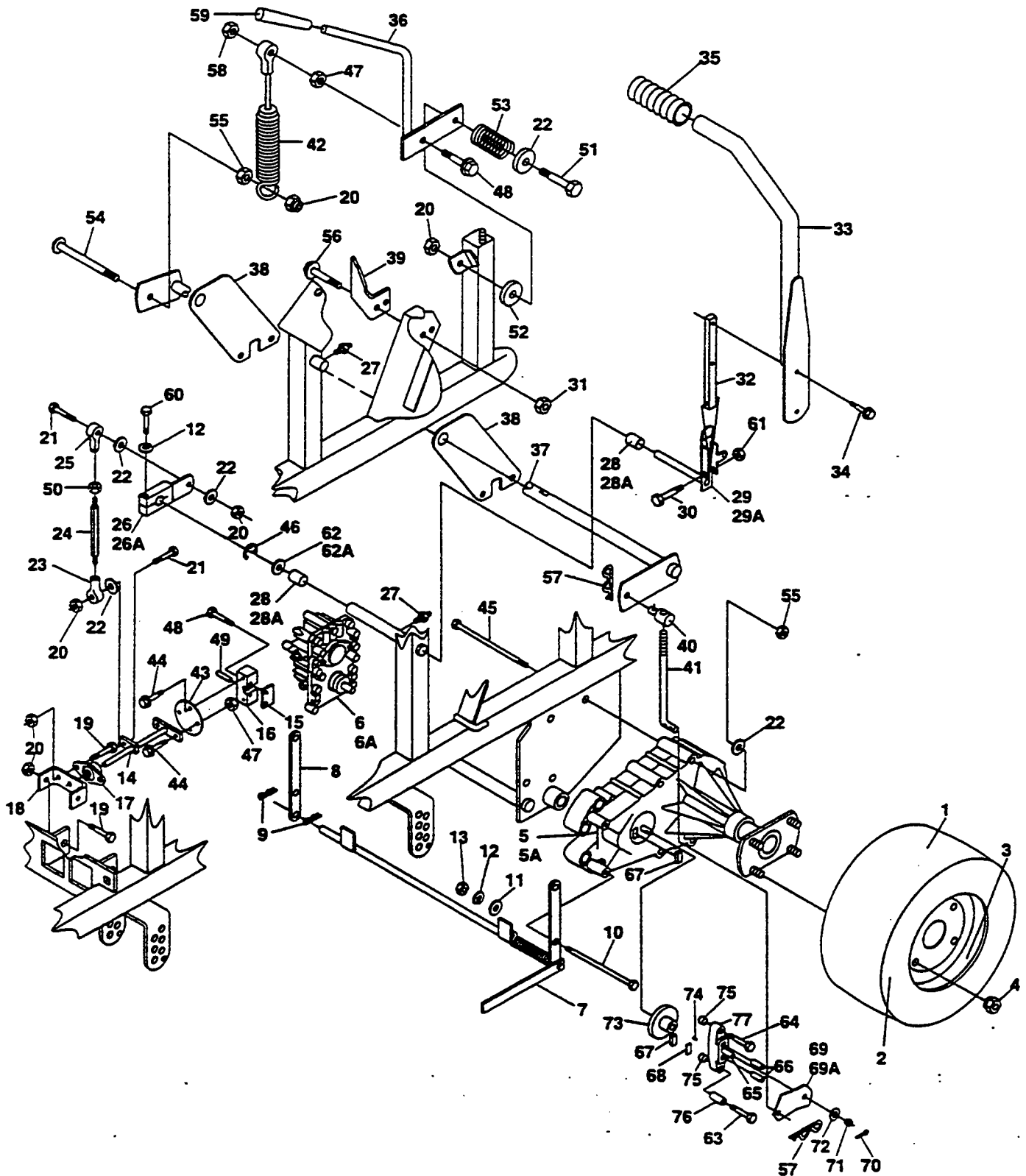

BRAKE AND STEERING CONTROLS

Ref. Part No.	Part Number	Description	Ref. Part No.	Part Number	Description
1	481011	Drive Wheel Assembly, SSZ-42"	37	45551	Cam Weldment, Parking Brake
1	48827	Drive Wheel Assembly, SSZ-48"	38	421262	Plate, Parking Brake
2	481011-02	Tire, 20 x 8.00-8, SSZ-42"	39	421266	Latch, Brake
2	48827-02	Tire, SSZ-48"	40	43256	Swivel Joint
3	481011-03	Rim,SSZ-42"	41	44080	Rod, Brake
3	48827-03	Rim, SSZ-48"	42	48840	Cable Assembly, Parking Brake
4	04028-01	Lug Nut, 1/2-20	43	421238	Plate, Coupler
5	48782	Axle, LH	44	04017-05	Cap Screw, 1/4-20 x 3/4" Serr. Flange
5A	48783	Axle, RH	45	*	Hex Head Bolt, 3/8-16 x 4"
6	48784	Pump, LH	46	04050-02	Retaining Ring 3/4" External "E"
6A	48785	Pump, RH	47	04019-02	Nut, 1/4-20 Serr. Flange
7	45464	Dump Valve, Lever Weldment	48	04017-07	Cap Screw, 1/4-20 x 1-1/4" Serr. Flange
8	421212	Mounting Bracket	49	04060-06	Roll Pin, 3/16 x 3/4"
9	04062-01	Hair Pin	50	*	Hex Nut, 3/8-24
10	04001-95	Hex Head Bolt, 5/16-18 x 5"	51	*	Hex Head Bolt, 3/8-16 x 2"
11	*	Flat washer, 5/16"	52	04041-12	Flat Washer, 3/8 x 1-1/2" x 16ga.
12	*	Lock washer, 5/16"	53	48050	Spring, Brake Lever
13	*	Hex Nut, 5/16-18	54	*	Carriage Bolt, 3/8-16 x 1-1/2"
14	45462	Pump Weldment Shaft	55	04019-04	Nut, 3/8-16 Serr. Flange
15	421203	Clamp Plate	56	04017-16	Cap Screw, 5/16-18 x 3/4" Serr. Flange
16	48829	Block, Pump Control	57	04062-02	Hair Pin, 1/16" diameter
17	48796	Bushing, Self Align	58	*	Elastic Stop Nut, 1/4-20
18	421204	Bearing Bracket	59	48342	Grip, Parking Brake
19	*	Hex Head Bolt, 3/8-16 x 1"	60	*	Hex Head Bolt, 5/16-18 x 1-1/2"
20	*	Elastic Stop Nut, 3/8-16	61	04021-10	Elastic Stop Nut, 5/16-18
21	*	Hex Head Bolt, 3/8-16 x 1-1/2"	62	04041-08	Flat washer, 3/4"
22	04041-07	Flat washer, 3/8" Special	62A	04041-08S	Flat washer, 3/4" Special
23	48544	Ball Joint, LH Thread	63	HG44612	Bolt, 1/4-20 x 2 1/2 GR. 5 w/ patch
24	43246	Link, Turnbuckle	64	HG44276	Bolt, 1/4-20 x 1 1/2 GR. 5 w/ patch
25	48464	Ball Joint, RH Thread	65	HG44138	Bolt, Square Head
26	45460	Lever, Pump Transfer LH	66	HG44127	Pins, Actuating
26A	45461	Lever, Pump Transfer RH	67	HG44132	Brake Puck
27	48114-04	Grease Fitting	68	HG44134	Backing Plate
28	48100-06	Bushing, LH	69	HG44094	Actuating Lever, RH
28A	48100-05	Bushing, RH	69A	HG44613	Actuating Lever, LH
29	45435	Control Lever, LH	70	*	Cotter Pin
29A	45436	Control Lever, RH	71	HG44142	Castle Nut
30	*	Hex Head Bolt, 5/16-18 x 1-1/2"	72	HG44130	Washer
31	04019-03	Nut, 5/16-18 Serrated lange Hex Hd.	73	HG44090	Disc
32	421145	Bar Control Lever	74	HG44143	Key, Woodruff Special
33	45437	Control Handle	75	HG23770	Spacer, Small
34	04017-27	Cap Screw, 3/8-16 x 1", Serr. Flange	76	HG23711	Spacer, Large
35	48093	Grip, Control Handle	77	HG44092	Yoke Brake
36	45482	Lever Weldment, Parking Brake			

* Common hardware which should be purchased locally. All bolts grade 5 plated, all other fasteners zinc plated.

INSTRUMENT PANEL AND ELECTRICAL COMPONENTS

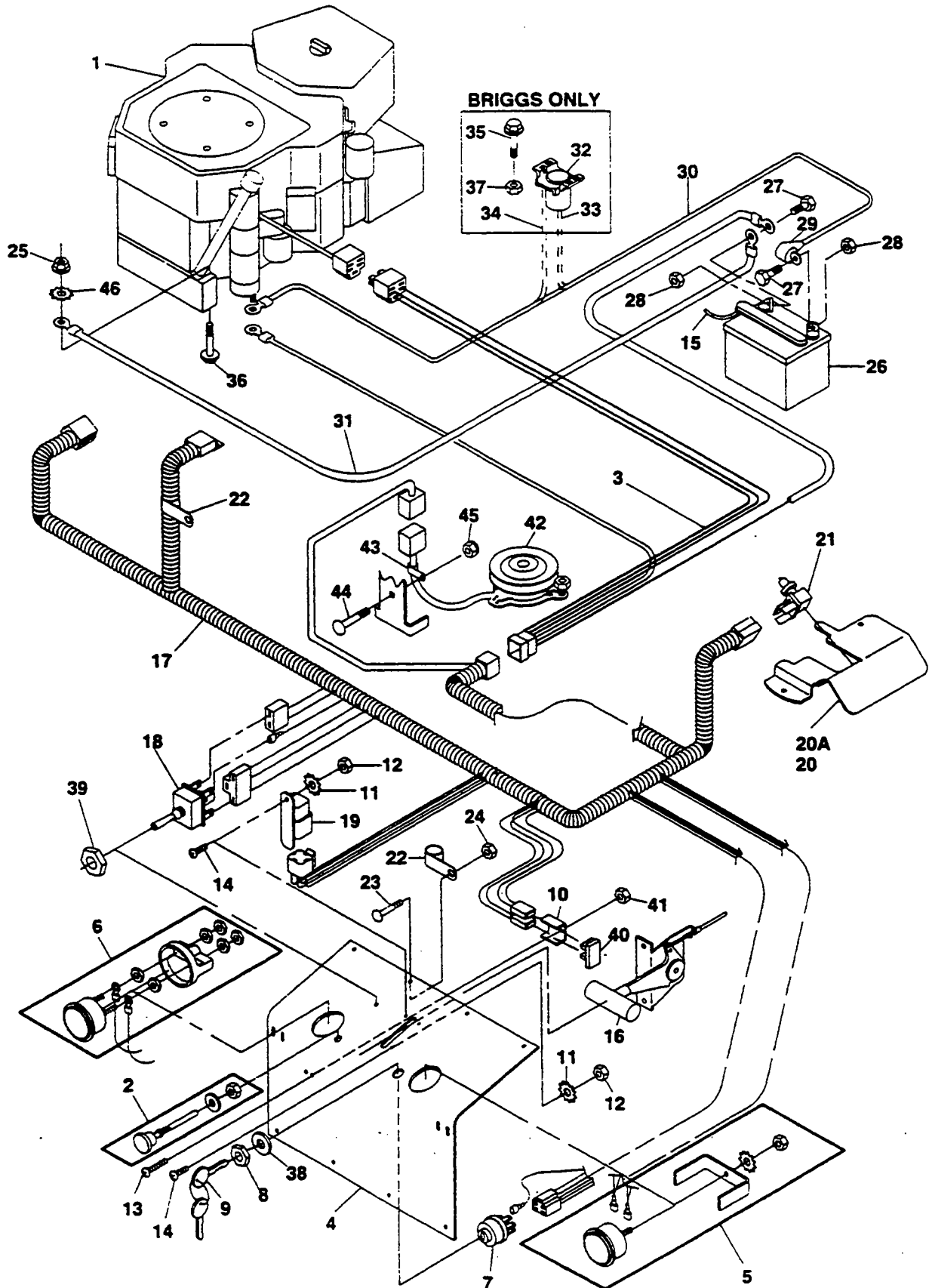

INSTRUMENT PANEL AND ELECTRICAL COMPONENTS

Ref. No.	Part Number	Description	16BV	18CV
1	48766	Engine 16 hp Briggs Vanguard	X	
1	48835	Engine 18 hp Kohler Command		X
2	48091	Choke Control	X	
2	48780	Choke Control		X
3	48857	Adapter		X
3	48801	Adapter	X	
4	421164	Kick Plate	X	X
5	48023	Hour Meter (Include Hardware)	X	X
6	48022	Ammeter (Include Hardware)	X	X
7	48798	Key Switch (Includes Mounting Hardware)	X	X
8	48017-04	Hex Nut, 5/8-32"	X	X
9	48017-02	Key & Ring Assembly	X	X
10	42413	Bracket, Fuse Holder	X	X
11	.	Lockwasher #10 External Tooth	X	X
12	.	Hex Nut #10-32	X	X
13	.	Screw, Phillips Washer Head #10-32 x 1-1/2"	X	X
14	.	Screw, Phillips Washer Head #10-32 x 1/2"	X	X
15	48015-01	Overflow Tube	X	X
16	48879	Throttle Control	X	X
17	48781	Wire Harness	X	X
18	48787	Switch, Mower Engagement Electric Clutch	X	X
19	48788	Relay	X	X
20	421253	Neutral Lock Bracket, RH	X	X
20A	421252	Neutral Lock Bracket, LH	X	X
21	48522	Switch Neutral Lock	X	X
22	48030-06	Clamp	X	X
23	.	Carriage Bolt, 5/16-18 x 1"	X	X
24	.	Elastic Stop Nut, 5/16-18	X	X
25	04019-03	Nut, 5/16-18 Serrated Flange Hex Head	X	X
26	48015	Battery	X	X
27	.	Hex Head Bolt, 1/4-20 x 1/2"	X	X
28	.	Nut, 1/4-20	X	X
29	48126	Rubber Boot	X	X
30	48029-13	Battery Cable, 25" Red		X
31	48029-11	Battery Cable, 27" Black	X	X
32	48016	Solenoid	X	
33	48029-06	Battery Cable, 18" Red	X	
34	48029-03	Battery Cable, 13-3/4" Red	X	
35	04017-05	Bolt, 1/4-20 x 3/4" Serrated Flange Hex Head	X	X
36	04017-19	Cap Screw, 5/16-18 x 1 1/2"	X	X
37	04019-02	Nut, 1/4-20 Serrated Flange Hex Head	X	X
38	48017-03	Lockwasher, 5/8" Internal	X	X
39	48787-01	Hex Nut, 1/2-27	X	X
40	48298	Blade Type Fuse, 20 amp	X	X
41	04021-01	Elastic Stop Nut #10-32	X	X
42	48786	Electric Clutch	X	X
43	48030-09	Clamp	X	X
44	.	Carriage Bolt, 5/16-18 x 3/4"	X	X
45	04021-10	Elastic Stop Nut, 5/16-18	X	X
46	04031-09	Lockwasher, 5/16" Internal Tooth	X	X
47	04017-20	Cap Screw, 5/16-18 x 1 3/4"	X	X

* Common hardware which should be purchased locally. All bolts Grade 5 plated, all other fasteners zinc plated.

ELECTRICAL WIRING DIAGRAM - KOHLER ENGINE

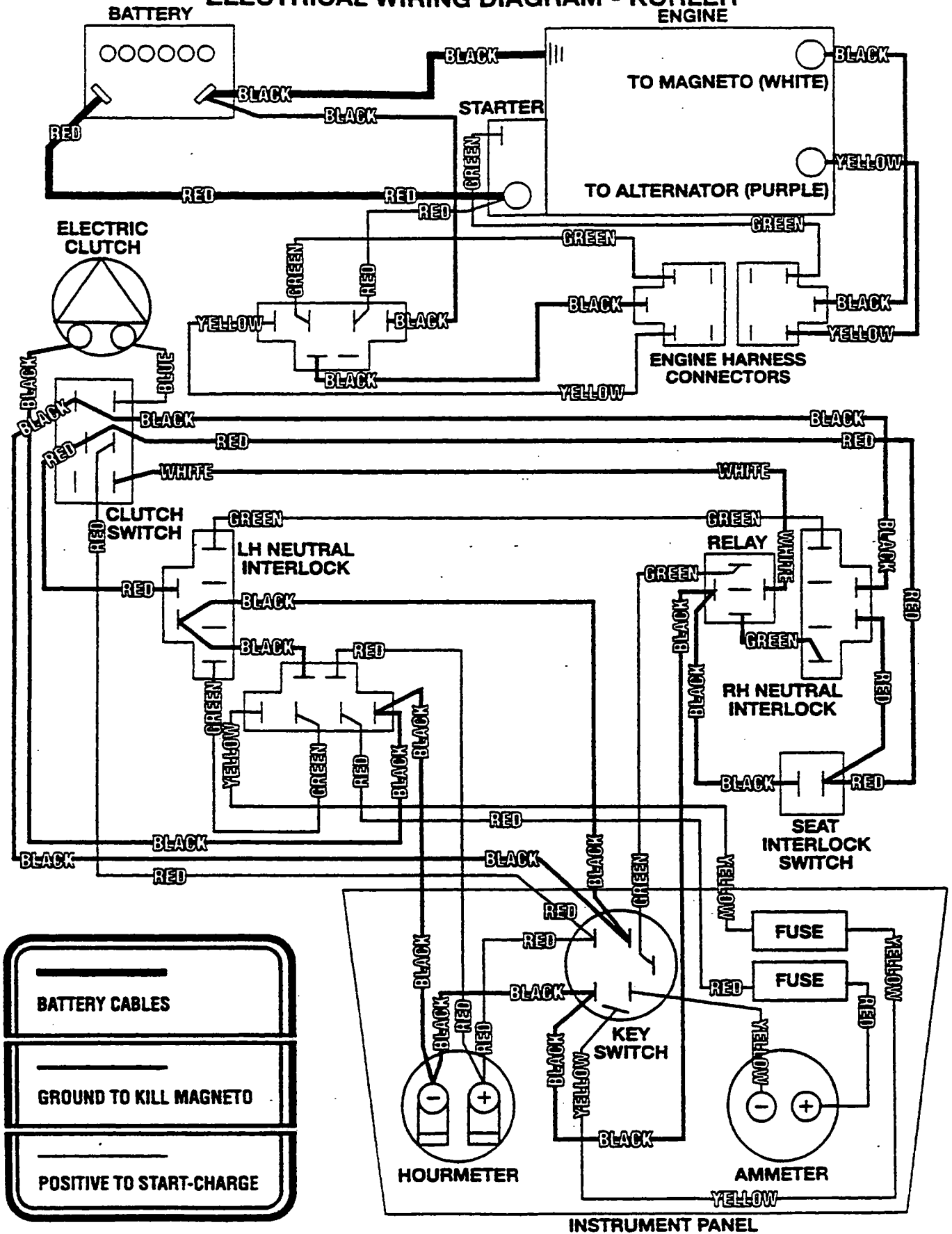

ELECTRICAL WIRING DIAGRAM - BRIGGS & STRATTON VANGUARD

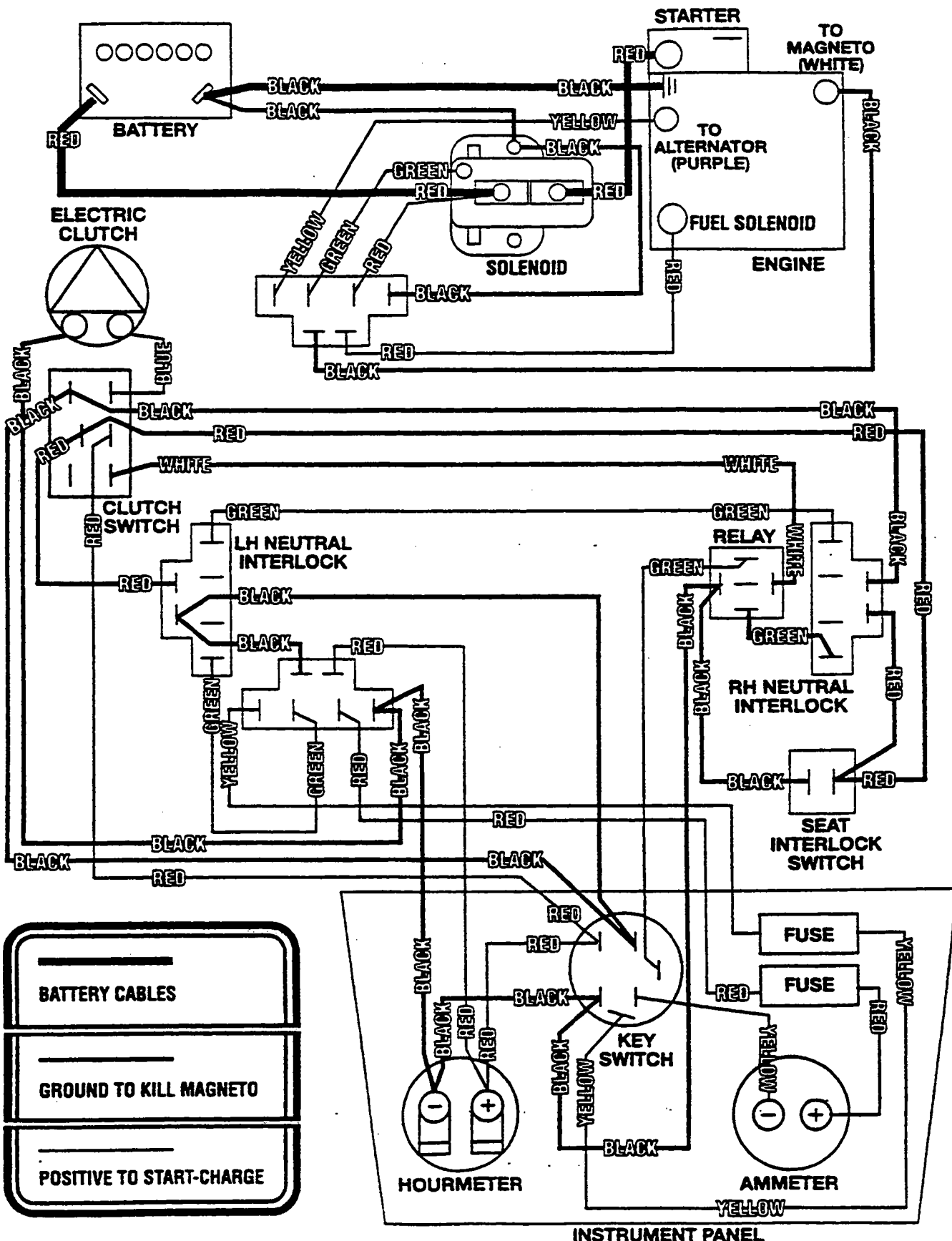

REPLACEMENT DECALS



48556 - Size 12" x 3.25"



48859 - Size 11.5" x 5.5"



48623 - Size 12" x 3.25"



48318



48404



48825 - Size 8.5" x 2"



48072

IMPORTANT ADJUSTMENT PROCEDURES

READ OPERATOR'S MANUAL FOR MORE DETAILS

TRANSMISSION DRIVE BELT TENSION

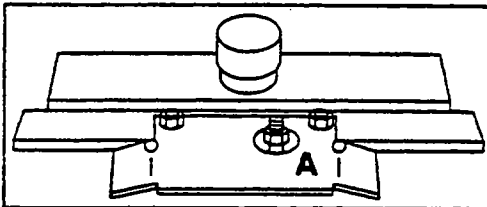

To adjust transmission drive belt tension, tighten or loosen nut (A) on J-hook connected to transmission drive idler. Under proper tension, belt should move 1/4" with 10 pounds of pressure. **IMPORTANT!** If drive belt is too tight, pump or belt failure is likely to occur.

FREE WHEEL OPERATION

To move machine without running the engine, locate dump valve lever under fender in front of left drive wheel. Unhook and push forward to free wheel. Pull lever back and rehook for normal operation.

STRAIGHT-LINE RUNNING OR TRACKING ADJUSTMENT

Before making adjustment, be sure both drive tires are inflated equally. Loosen nut (D) on LH pump linkage. If machine pulls to right, move forward in slot to slow left wheel. If machine pulls to left, move rearward in slot to speed up left wheel. Readjust neutral if necessary.

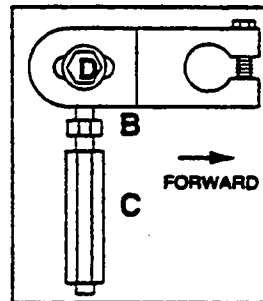

NEUTRAL ADJUSTMENT

Adjust neutral only with drive wheels elevated and machine blocked securely. Loosen jam nut (B) on the turnbuckle. If wheel rotates forward, adjust turnbuckle (C) clockwise. If wheel rotates rearward, adjust turnbuckle counter-clockwise. Adjust until drive wheel stops turning. Tighten jam nut.

HYDRAULIC FLUID LEVEL

Check hydraulic fluid level daily while fluid is cool. Fluid level should be 1/2" to 1" below bottom edge of fill sleeve. Fill with SAE 20W50 motor oil only.

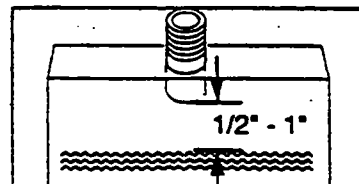

IMPORTANT! Do Not overfill. Room for hot fluid expansion must be allowed or resulting expansion may cause leaks in the system.



WARNING

INSTALL BELT COVERS BEFORE OPERATING MACHINE
READ OPERATOR'S MANUAL

REPLACEMENT DECALS

PARKING BRAKE OFF

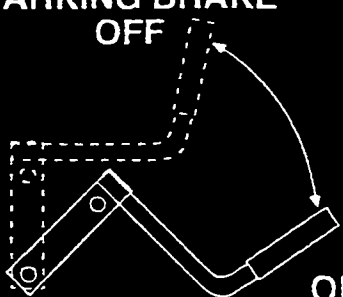

ON

CAUTION

AVOID INJURY FROM BURNS
SHUT OFF ENGINE BEFORE
REMOVING FUEL TANK CAP

• UNLEADED GASOLINE ONLY

48874

! DANGER



**SPINNING BLADE
KEEP CLEAR
CONTACT CAN INJURE**

48071

! WARNING

**INSTALL BELT COVERS BEFORE
OPERATING MACHINE
READ OPERATOR'S MANUAL**

48712

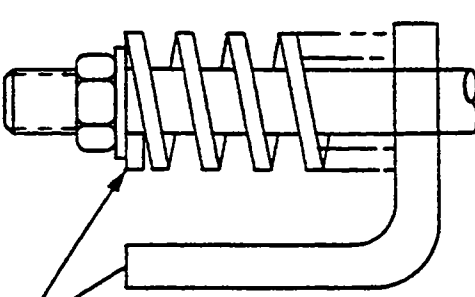

**FOR CORRECT BELT TENSION
TIGHTEN NUT UNTIL SPRING
ALIGNS WITH BRACKET EDGE
SEE OPERATOR'S MANUAL**

48873

! WARNING

ROTATING BLADES AND BELTS

- KEEP HANDS, FEET & CLOTHING CLEAR
- KEEP ALL GUARDS IN PLACE
- SHUT OFF ENGINE & DISENGAGE BLADE CLUTCH BEFORE SERVICING
- CLEAN AREA OF DEBRIS BEFORE MOWING
- USE CAUTION IN DIRECTING DISCHARGE
- KEEP BYSTANDERS, CHILDREN & PETS AWAY
- READ INSTRUCTION MANUAL BEFORE OPERATING

DO NOT OPERATE WITHOUT DISCHARGE CHUTE, MULCHING KIT, OR ENTIRE GRASS CATCHER INSTALLED

48073

! WARNING



**PINCH POINT
KEEP HANDS
AND FEET AWAY**

48715

FORWARD

ON OFF

START / DRIVE PROCEDURE

- ENGAGE PARKING BRAKE
- DISENGAGE MOWER DRIVE
- MOVE CONTROL HANDLES TO NEUTRAL LOCK POSITION
- START ENGINE
- RELEASE PARKING BRAKE
- SELECT FORWARD OR REVERSE SPEED WITH HYDRO CONTROL HANDLES

FAST

START STOP

SLOW

**! MOWER ON
PULL UP AND PUSH FORWARD TO ENGAGE**

**! MOWER OFF
PULL BACK TO DISENGAGE**

**BEFORE OPERATING
READ OPERATOR'S
MANUAL AND SAFETY
INSTRUCTIONS**

FORWARD

NEUTRAL

REVERSE

NEUTRAL

REVERSE

SCAG

48869

SCAG
POWER EQUIPMENT

Model
SSZ-20CV
SSZ-22CV
SMZ-52
SMZ-61

From S/N 40000 To 49999

ILLUSTRATED PARTS LIST

PART NO. 06003

TABLE OF CONTENTS

Illustrated Parts Listings	2-13
Cutter Deck	2-3
Cutter Deck Controls	4-5
Sheet Metal Components	6-7
Hydraulic Components	8-9
Traction Drive Components	10-11
Brake and Steering Controls	12-13
Instrument Panel and Electrical Components	14-15
 Electrical Wiring Diagrams.....	 16-17
 Replacement Decals.....	 18-19

52" & 61" CUTTER DECK

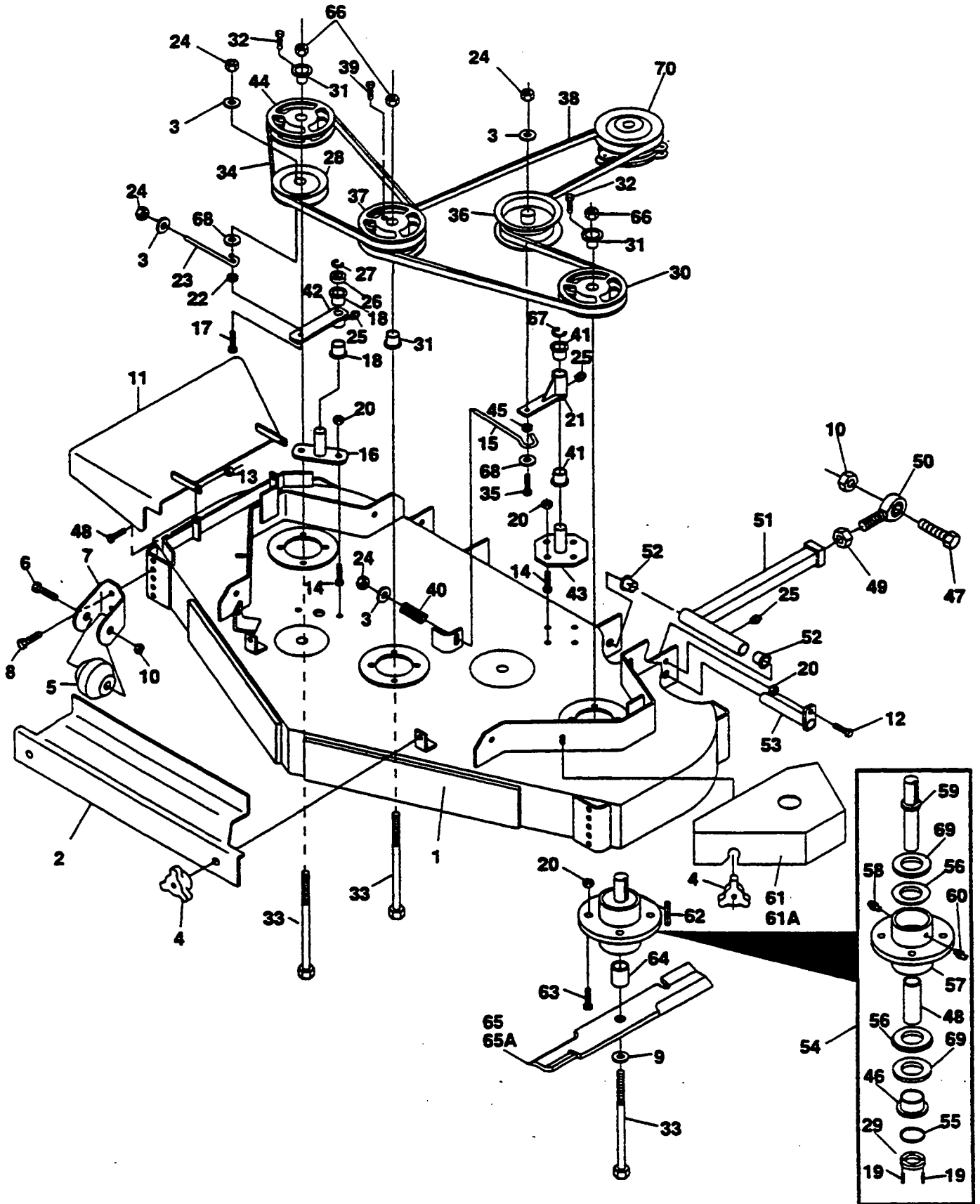

52" & 61" CUTTER DECK

Ref. No.	Part Number	Description	Ref. No.	Part Number	Description
1	46615	52" Cutter Deck (Includes decals)	37	48940	Pulley, Double Groove 61" Deck
1	46611	61" Cutter Deck (Includes decals)	38	481001	Belt, Blade Drive 52" Deck
2	421299	Belt Cover, Front 61" Deck	38	48996	Belt, Blade Drive 61" Deck
2	421451	Belt Cover, Front 52" Deck	39	.	Hex Head Bolt, 1/4-20 x 1 1/4"
3	04041-07	Flatwasher, 3/8" Special	40	48807	Spring, Idler Tension
4	04029-03	Wing Nut, 3/8-16	41	48100-02	Bushing
5	48584	Anti-Scalp Wheel	42	46600	Idler Arm (Includes bushings & grease fitting)
6	.	Hex Head Bolt, 5/8-11 x 4-1/2"	43	45329	Idler Pivot Base
7	42882	Anti-Scalp Wheel Bracket	44	48924	Pulley
8	04017-27	Cap Screw, 3/8-16 x 1" Serrated Flange Hex Head	45	43282	Spacer
9	04040-10	Flatwasher 5/8" (.688 x 1.75 x .134)	46	43217	Bushing, Tapered Spindle
10	.	Hex Nut, 5/8-11 Elastic Stop	47	.	Hex Head Bolt, 5/8-11 x 3"
11	45331	Discharge Chute 52" Deck	48	43218	Spacer, Tapered Spindle
11	45440	Discharge Chute 61" Deck	49	.	Hex Nut, 5/8-18 UNF
12	04017-17	Cap Screw, 5/16-18 x 1" Serrated Flange Hex Head	50	48763	Rod End
13	.	Hex Nut, 5/16-18 Elastic Stop	51	46460	Push Arm (Includes 25,49,50 & 52)
14	04017-16	Cap Screw, 5/16-18 x 3/4" Serrated Flange Hex Head	52	48100-06	Bushing
15	44101	"J" Rod	53	45332	Push Arm Shaft
16	45037	Idler Pivot Base	54	46400	Cutter Spindle Assembly (Complete, Tapered)
17	.	Hex Head Bolt, 3/8-16 x 2-1/4"	55	04050-04	Retaining Ring, 1" External, Inverted
18	48100-05	Bushing	56	48668	Bearing & Cup, Tapered Spindle
19	.	Roll Pin 1/8 x 1/2"	57	41008	Spindle Housing, Tapered Spindle
20	04019-03	Nut, 5/16-18 Serrated Flange Hex Head	58	48114-02	Grease Fitting
21	46602	Idler Arm, (Includes bushings & grease fitting)	59	45391	Spindle Shaft, Tapered Spindle
22	43077	Spacer	60	48667	Relief Fitting, Tapered Spindle
23	43028	"J" Rod	61	42889	Belt Cover - LH 52" Deck
24	.	Hex Nut, 3/8-16 Elastic Stop	61	421292	Belt Cover - LH 61" Deck
25	48114-04	Grease Fitting	61A	42890	Belt Cover - RH 52" Deck
26	04041-08	Flatwasher 3/4"	61A	421293	Belt Cover - RH 61" Deck
26A	04041-08S	Flatwasher, 3/4" Special	62	04063-08	Key, 1/4 x 1/4 x 2"
27	04050-02	Retaining Ring, 3/4" External "E"	63	04017-18	Cap Screw, 5/16-18 x 1-1/4" Serrated Flange Hex Head
28	48181	Pulley, Idler	64	43279	Spacer-Tapered Spindle
29	43201	1/4" Blade Spacer	65	48108	Cutter Blade, 18" Standard 52" Deck
30	48924	Pulley 52" Deck	65	48111	Cutter Blade, 21" Standard 61" Deck
30	48753	Pulley 61" Deck	65A	48185	Cutter Blade, 18" High Lift 52" Deck
31	48141	Tapered Hub	65A	48304	Cutter Blade, 21" High Lift 61" Deck
32	.	Hex Head Bolt, 1/4-20 x 3/4"	66	.	Hex Nut, 5/8-11
33	04001-41	Hex Head Bolt, 5/8-11 x 9-1/2"	67	04050-05	Retaining Ring 1-1/8" External "E"
34	48285	Belt, RH Blade Drive 52" Deck	68	04041-12	Flatwasher, 3/8" (3/8 x 1.5 x .06)
34	48265	Belt, RH Blade Drive 61" Deck	69	48681	Seal, Tapered Cutter Spindle
35	.	Hex Head Bolt, 3/8-16 x 4-1/2"	70	48786	Electric Clutch
36	48550	Pulley, Idler - Cutter Engagement			
37	48923	Pulley, Double Groove 52" Deck			

* Common hardware which should be purchased locally. All bolts Grade 5 plated, all other fasteners zinc plated.

CUTTER DECK CONTROLS

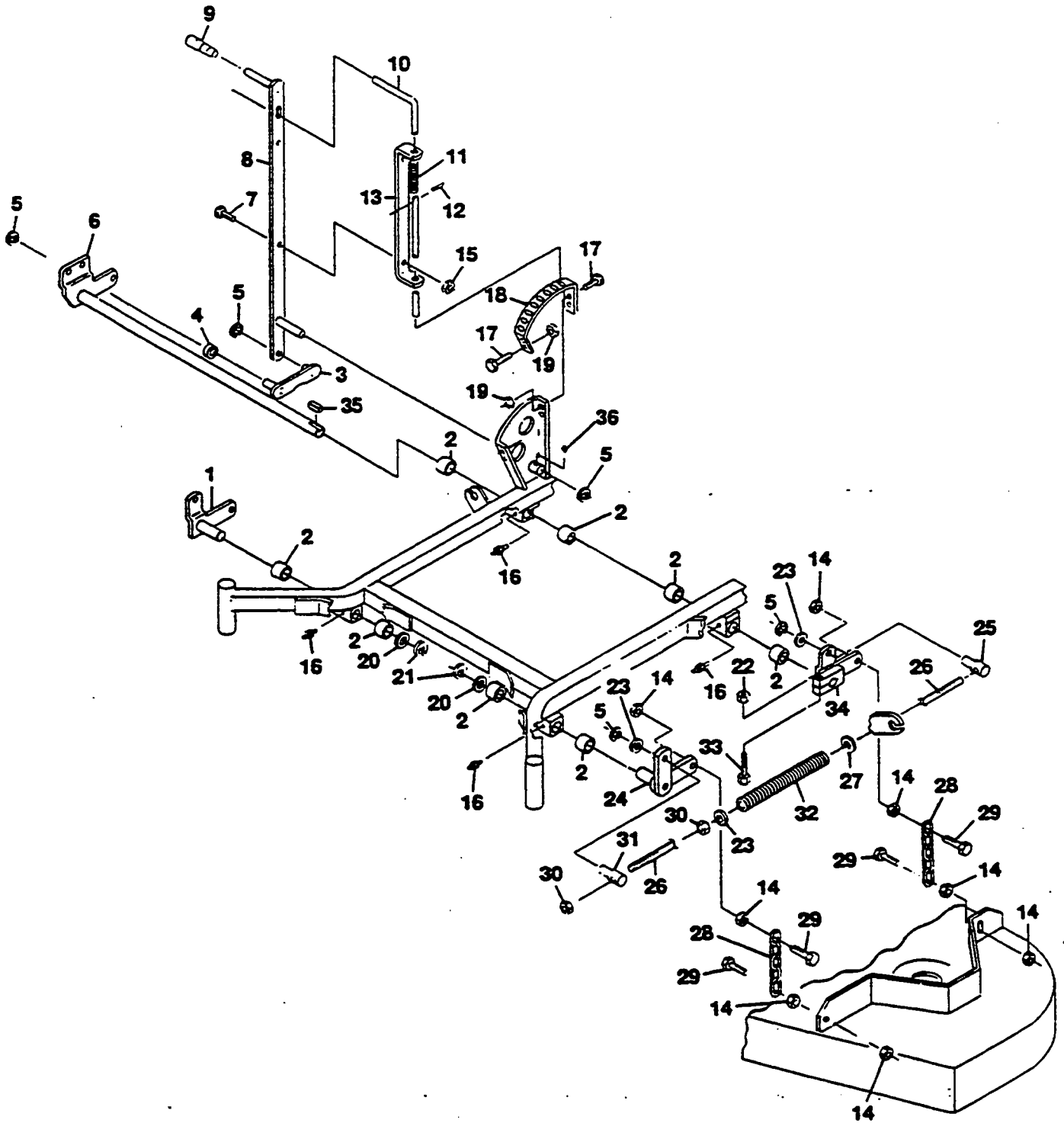

CUTTER DECK CONTROLS

Ref. No.	Part Number	Description	Ref. No.	Part Number	Description
1	45524	Bellcrank, Lift - Right Front	18	42828	Strip, Height Adjustment
2	48100-05	Bushing	19	04019-02	Nut, 1/4-20 Serrated Flange
3	45527	Lift Link	20	04041-08S	Flat Washer, 3/4" Special
4	43180	Bushing	21	04050-02	Retaining Ring, 3/4" External "E"
5	04050-01	Retaining Ring, 5/8" External "E"	22	.	Elastic Stop Nut 3/8-16
6	45523	Lift Arm Weldment	23	04040-09	Flat Washer, 5/8" Special
7	04017-17	Capscrew, 5/16-18 x 1" Serrated Flange Hex Head	24	45313	Bellcrank, Lift - Left Front
8	46384	Height Adjustment Lever (includes grip)	25	43271	Swivel Joint - LH
9	48093	Grip, Lift Lever	26	04004-15	Adjustment Stud
10	44065	Rod, Cutter Deck Lock	27	04040-10	Flat Washer, 5/8" ID
11	48053	Spring, Deck Lift Index	28	48540	Chain
12	04060-01	Roll Pin, 5/32 x 3/4"	29	.	Hex Head Bolt, 3/8-16 x 1-1/2"
13	42887	Lock Rod Guide	30	.	Hex Nut, 5/8-11
14	04019-04	Nut 3/8-16 Serrated Flange	31	43270	Swivel Joint - RH
15	04019-03	Nut, 5/16-18 Serrated Flange	32	48953	Spring, Deck Lift
16	48114-04	Grease Fitting	33	.	Hex Head Bolt, 3/8-16 x 2"
17	04017-05	Capscrew, 1/4-20 x 3/4" Serrated Flange Hex Head	34	45427	Bellcrank, Lift - Left Rear
			35	04063-17	Key, 3/16 x 3/16 x 1"
			36	48114-05	Grease Fitting

* Common hardware which should be purchased locally. All bolts Grade 5 plated, all other fasteners zinc plated.

SHEET METAL COMPONENTS

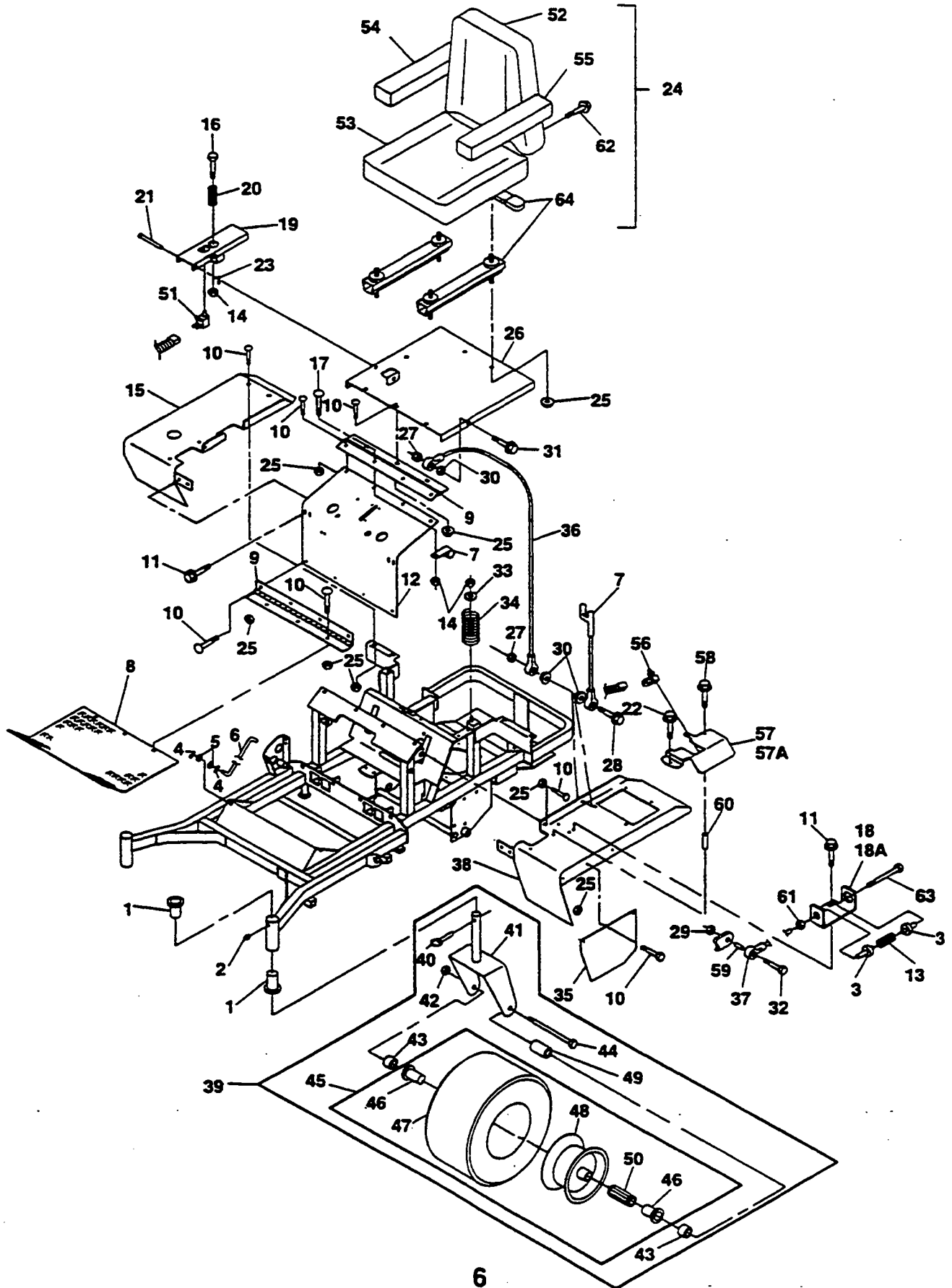

SHEET METAL COMPONENTS

Ref. No.	Part Number	Description	Ref. No.	Part Number	Description
1	48100-08	Bushing	32	*	Hex Head Bolt, 3/8-16 x 2-1/2"
2	48114-04	Grease Fitting	33	*	Flatwasher, 5/16"
3	43257	Bushing, Spring Keeper	34	48686	Seat Spring
4	04062-02	Hair Pin, .08 Diameter	35	421198	Fender Panel, LH
5	04041-07	Flatwasher, 3/8" Special	36	48566	Cable, Seat Stop
6	44062	Rod, Foot Plate Latch	37	48464	Ball Joint, Neutral
7	48994	Cable, Seat Stop	38	45479	Fender - LH
8	42764	Foot Plate	39	46392	Caster Wheel Yoke Assembly, Complete
9	48547	Hinge	40	04066-01	Quick Pin
10	*	Carrriage Bolt, 5/16-18 x 3/4"	41	45325	Caster Wheel Yoke
11	04017-16	Cap Screw, 5/16-18 x 3/4" Serrated Flange Hex Head	42	*	Elastic Stop Nut, 1/2-13
12	421251	Kick Plate	43	43041	Spacer
13	48746	Neutral Return Spring	44	*	Hex Head Bolt, 1/2-13 x 6-1/2"
14	04021-10	Elastic Stop Nut, 5/16-18	45	48537	Wheel Assembly, Complete
15	46505	Fender Assembly, RH (with decal)	46	48006-07	Retainer
16	*	Hex Head Bolt, 5/16-18 x 3-3/4"	47	48537-02	Tire Only
17	*	Carrriage Bolt, 5/16-18 x 1"	48	48537-03	Rim Only
18	421411	Retainer, Neutral Spring, LH	49	43022	Sleeve
18A	421412	Retainer, Neutral Spring, RH	50	48006-06	Roller Bearing
19	45405	Seat Switch Bracket	51	48717	Seat Switch
20	48463	Spring	52	48704-02	Seat Back Cushion
21	04064-04	Clevis Pin	53	48704-03	Seat Bottom Cushion Assembly
22	04017-15	Cap Screw, 5/16-18 x 1/2" Serrated Flange Hex Head	54	48704-04	Arm Pad, RH
23	04062-02	Hair Pin Cotter	55	48704-05	Arm Pad, LH
24	48930	Seat Assembly w/ Adjuster Rails	56	48522	Neutral Interlock Switch
25	04019-03	Nut, 5/16-18 Serrated Flange Hex Head	57	421253	Neutral Lock Bracket, RH
26	45404	Seat Base	57A	421252	Neutral Lock Bracket, LH
27	*	Hex Nut, 1/4-20 Elastic Stop	58	04017-24	Cap Screw, 5/16-18 x 2-3/4" Serrated Flange Hex Head
28	04017-08	Capscrew 1/4-20 x 1-1/2" Serrated Flange Hex Head	59	43240	Spacer Neutral Spring
29	*	Elastic Stop Nut, 3/8-16	60	43258	Spacer, Neutral Lock Bracket
30	04019-02	Nut, 1/4-20 Serrated Flange Hex Head	61	*	Hex Nut, 3/8-24 UNF
31	04017-06	Cap Screw, 1/4-20 x 1" Serrated Flange Hex Head	62	48704-06	Hex Head Screw w/Washer, 1/4-20 x 3/4"
			63	04001-99	Hex Head Bolt, 3/8-24 x 6-1/2", UNF
			64	48931	Seat Adjustment; Track Set

* Common hardware which should be purchased locally. All bolts Grade 5 plated, all other fasteners zinc plated.

HYDRAULIC COMPONENTS

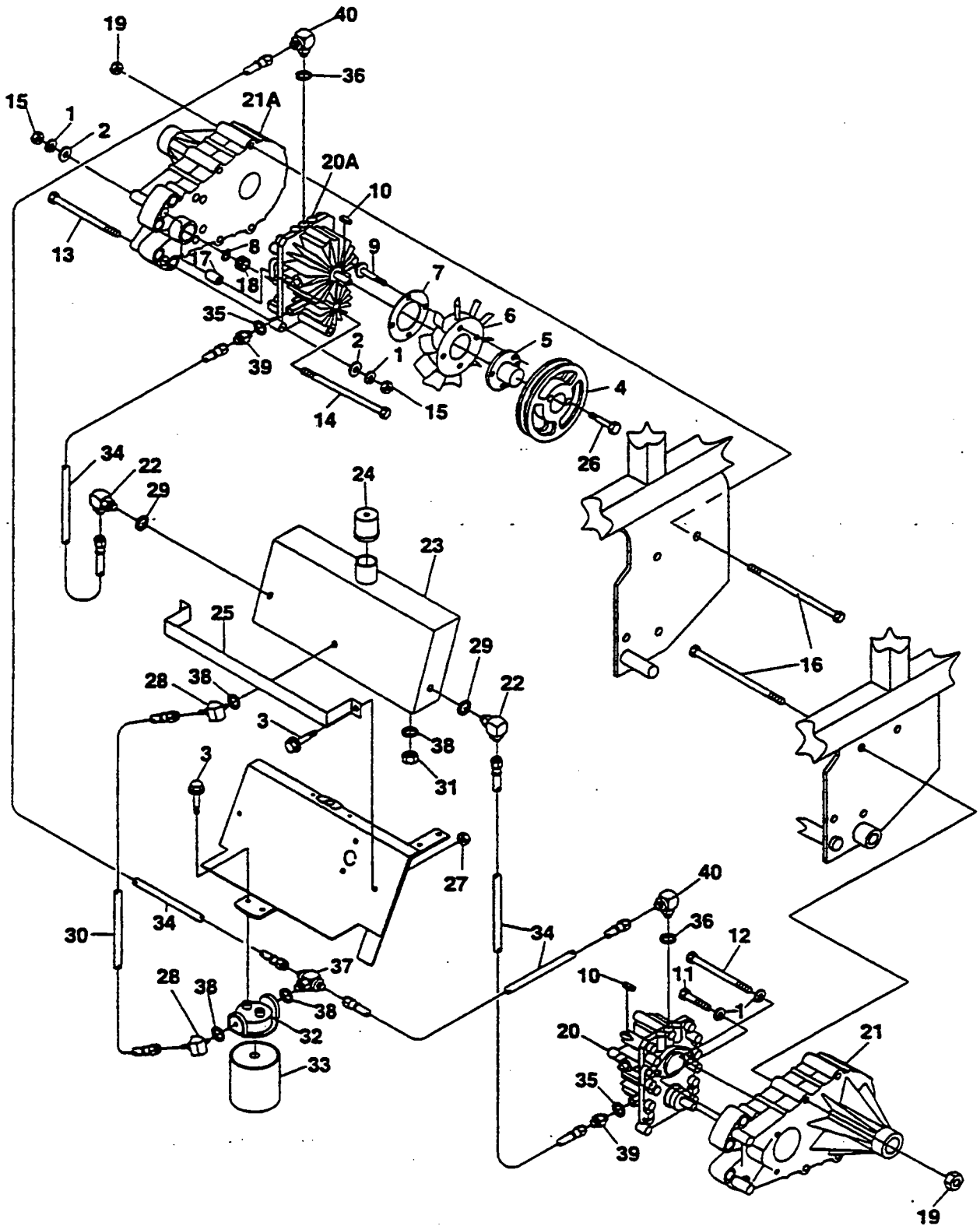

HYDRAULIC COMPONENTS

Ref. No.	Part Number	Description	Ref. No.	Part Number	Description
1	.	Lockwasher, 5/16"	22	48350-09	90 Degree Elbow, 9/16-18 JIC to 9/16 -18"O" Ring
2	.	Flatwasher, 5/16"	23	48860	Oil Tank Reservoir
3	04017-05	Cap Screw, 1/4-20 x 3/4" Serrated Flange Hex Head	24	48894	Cap, Oil Reservoir
4	48790	Pump Pulley	25	421208	Oil Reservoir Strap
5	48791	Tapered Hub, 15mm Bore	26	.	Hex Head Bolt, 1/4-20 x 1-1/4"
6	48789	Fan	27	.	Nut, 1/4-20 Elastic Stop
7	421209	Back-up Washer	28	48485-01	45 Degree Elbow, 3/4-16 JIC to 3/4-16 "O" Ring
8	04050-13	Snap Ring	29	48603-06	"O" Ring, 5/64 x 15/32 ID
9	04017-04	Cap Screw, 1/4-20 x 1/2" Serrated Flange Hex Head	30	48872	Hose Assembly, Filter Inlet
10	04063-14	Key, 5 x 5 x 25mm	31	48604-02	Plug, 3/4-16 "O" Ring
11	.	Hex Head Bolt 5/16-18 x 1-3/4"	32	48462-02	Head, Oil Filter
12	04001-96	Hex Head Bolt 5/16-18 x 4-1/2"	33	48462-01	Oil Filter, Special
13	04001-95	Hex Head Bolt 5/16-18 x 5"	34	48871	Hose Assembly
14	04001-94	Hex Head Bolt 5/16-18 x 7-1/2"	35	48603-04	"O" Ring, 3/32 x 3/4 ID
15	.	Nut, 5/16-18	36	48603-03	"O" Ring, 1/16 x 3/8 ID
16	.	Hex Head Bolt, 3/8-16 x 4"	37	48810-01	1/2", T-fitting, 3/4-16 JIC to 3/4-16 "O" Ring
17	48878	Spacer	38	48603-02	"O" Ring, 3/32 x 5/8 ID
18	48875	Gear	39	48572-02	Tube Union, 3/4-16 JIC to 7/8-14 "O" Ring
19	04019-04	Nut, 3/8-16 Serrated Flange Hex Head	40	48350-10	90 Degree Elbow, 9/16-18 JIC to 7/16-20 "O" Ring
20	48784	Pump, LH (Includes Spacers)			
20A	48785	Pump, RH (Includes Spacers)			
21	48782	Axle, LH, (Includes Brake Lever)			
21A	48783	Axle, RH, (Includes Brake Lever)			

* Common hardware which should be purchased locally. All bolts Grade 5 plated, all other fasteners zinc plated.

TRACTION DRIVE COMPONENTS

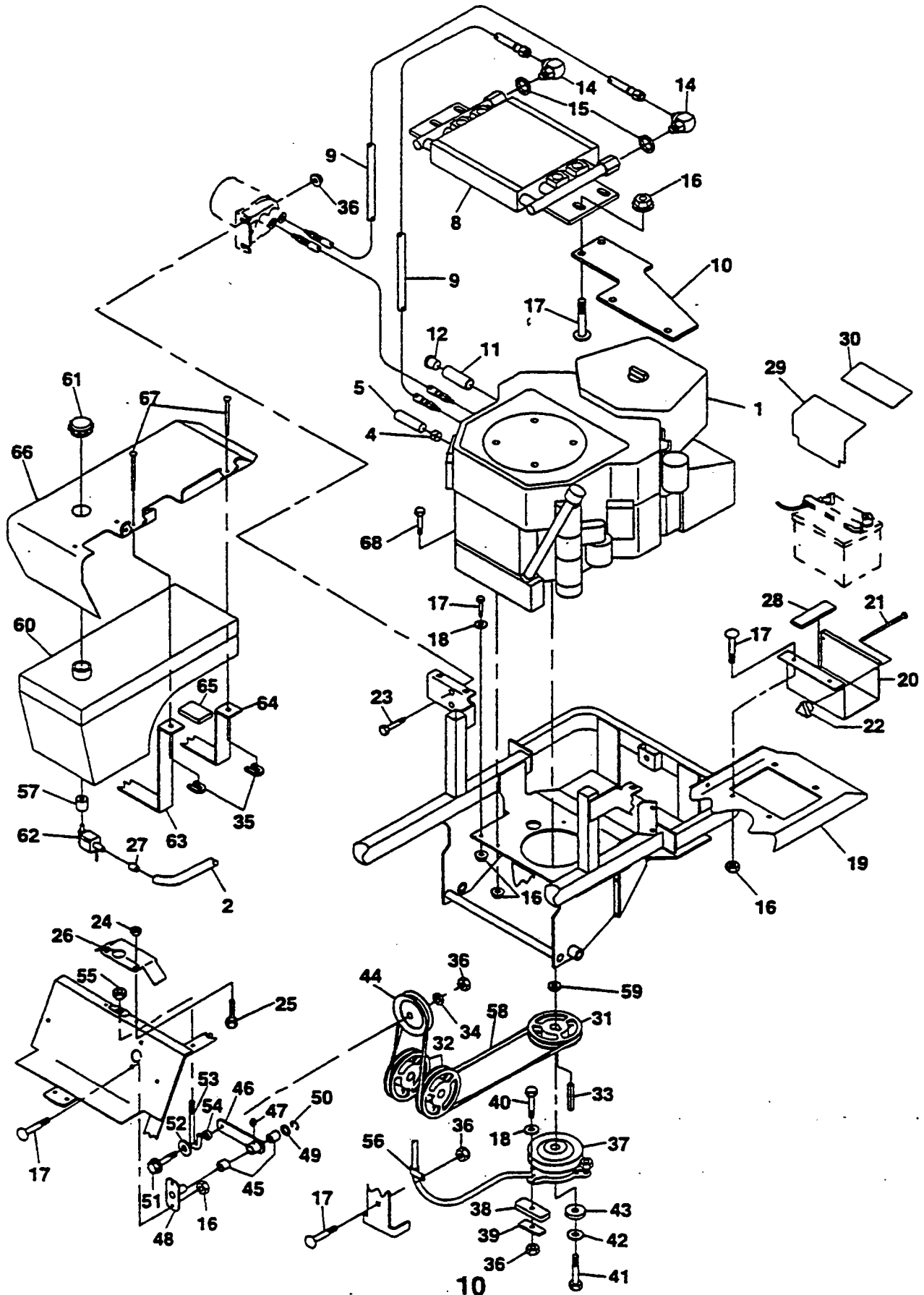

TRACTION DRIVE COMPONENTS

Ref. No.	Part Number	Description	20CV	22CV
1	48970	Engine 20 hp Kohler CV	X	
1	48972	Engine 22 hp Kohler CV		X
2	48058-03	Fuel Hose, 23" Long		
3	48029-13	Battery Cable, 25" Red	X	X
4	48633	Muffler Clamp		
5	48964	Tube, Exhaust	X	X
6	48962	Hose Assembly, Oil Cooler		X
7	48963-01	90 Degree Elbow, 1/2-20 SAE to 3/4 16 "O"-Ring		X
8	48645	Oil Cooler		X
9	48962	Hose, Oil Cooler		X
10	421386	Mounting Bracket, Oil Cooler		X
11	48402-02	Extension, 3"		X
12	48257	Pipe Cap		X

Ref. No.	Part Number	Description	Ref. No.	Part Number	Description
16	04019-03	Nut, 5/16-18 Serrated Flange Hex Head	44	48181	Idler Pulley
17	.	Carriage Bolt, 5/16-18 x 3/4"	45	48100-05	Bushing
18	.	Flatwasher, 5/16"	46	46081	Idler Arm (Includes bushings and grease fittings)
19	45479	Fender, LH	47	48114-04	Grease Fitting
20	421197	Battery Box	48	45037	Idler Pivot Base
21	.	Carriage Bolt, 1/4-20 x 6"	49	04041-08	Flatwasher, 3/4"
22	04029-01	Wing Nut, 1/4-20	49A	04041-08S	Flatwasher, 3/4" Special
23	.	Carriage Bolt, 5/16-18 x 1"	50	04050-02	Retaining Ring, 3/4" external "E"
24	04019-02	Nut, 1/4-20 Serrated Flange Hex Head	51	.	Hex Head Bolt, 3/8-16 x 2-1/4"
25	.	Carriage Bolt, 1/4-20 x 3/4"	52	04041-12	Flatwasher 3/8 x 1-1/2 x .06
26	421234	Belt Guard	53	44075	"J" Bolt
27	48059-01	Fuel Hose Clamp	54	43077	Spacer
28	48661	Rubber Pad	55	.	Elastic Stop Nut, 3/8-16
29	42392	Battery Cover	56	48030-09	Clamp
30	48099	Battery Cover Pad	57	48309	Bushing, Fuel Tank Valve
31	48792	Pulley	58	48760	Belt, Pump Drive
32	48790	Pump Pulley	59	43248	Spacer, Crankshaft
33	04063-01	Key, 1/4 x 1/4 x 1-1/4"	60	48651	Fuel Tank (Includes Shut-off Valve)
34	04041-07	Flatwasher, 3/8" Special	61	48311	Fuel Tank Cap
35	04110-01	U-Nut, 1/4-20	62	48568	Fuel Shut-off Valve
36	04021-10	Elastic Stop Nut, 5/16-18	63	42944	Fuel Tank Strap, Long
37	48786	Electric Clutch	64	42945	Fuel Tank Strap, Short
38	48814	Rubber Pad, Clutch Stop	65	48657	Rubber Pad
39	421215	Backing Plate	66	46505	Fender Assembly, RH (with decal)
40	.	Hex Head Bolt, 5/16-18 x 1-1/4"	67	.	Machine Screw, 1/4-20 x 2"
41	04001-93	Hex Head Bolt, 7/16-20 x 3"	68	04017-19	Capscrew, 5/16-18 x 1-1/2"
42	.	Lockwasher, 7/16"			
43	04041-18	Flatwasher, 7/16" Special			

* Common hardware which should be purchased locally. All bolts Grade 5 plated, all other fasteners zinc plated.

BRAKE AND STEERING CONTROLS

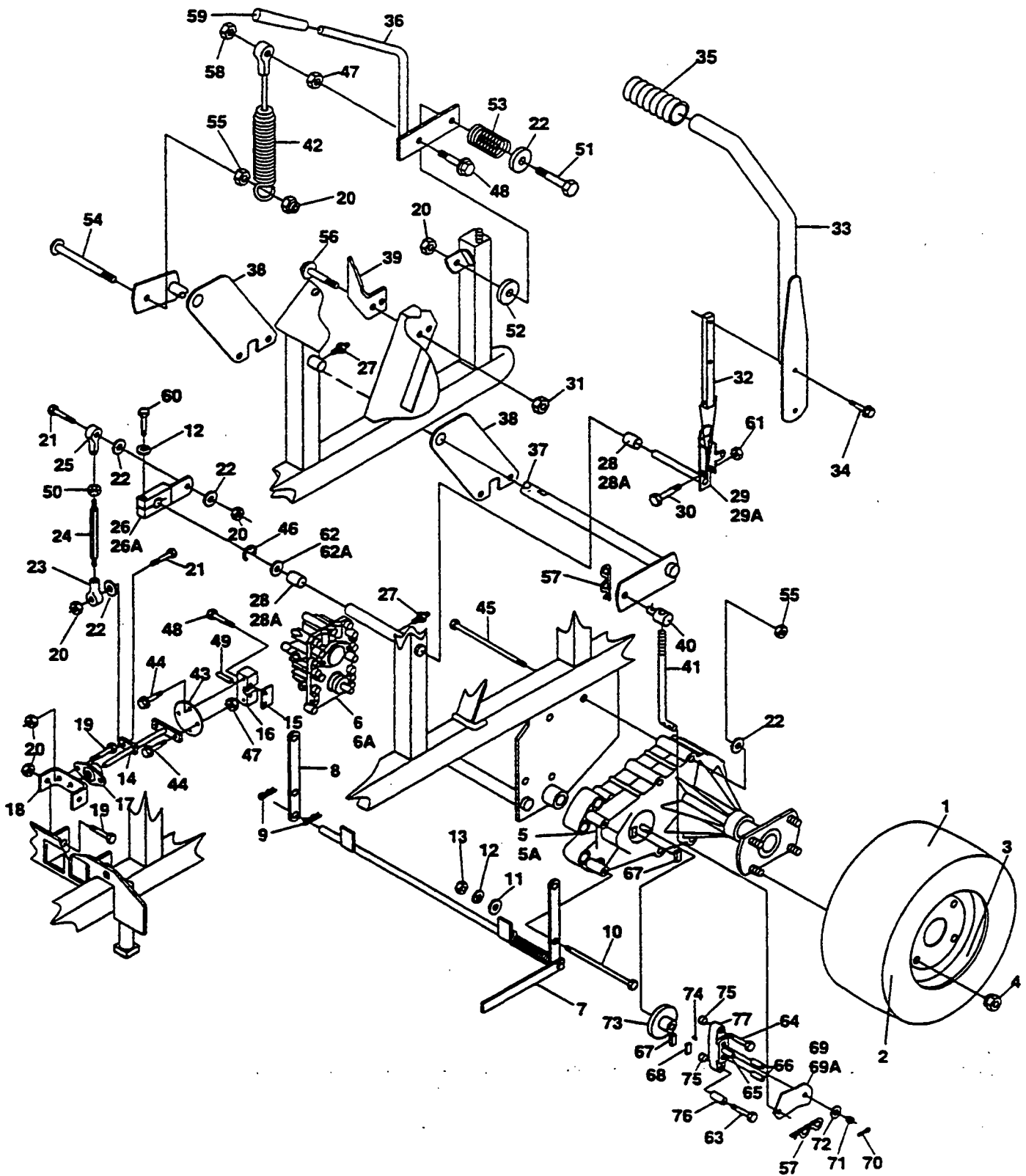

BRAKE AND STEERING CONTROLS

Ref. No.	Part Number	Description	Ref. No.	Part Number	Description
1	48958	Drive Wheel Assembly	39	421266	Latch, Brake
2	48827-02	Tire Only	40	43256	Swivel Joint
3	48958-03	Rim Only	41	44080	Rod, Brake
4	04028-01	Lug Nut, 1/2-20	42	48840	Cable Assembly, Parking Brake
5	48782	Axle, LH	43	421238	Plate, Coupler
5A	48783	Axle, RH	44	04017-05	Cap Screw, 1/4-20 x 3/4" Serrated Flange Hex Head
6	48784	Pump, LH	45	.	Hex Head Bolt, 3/8-16 x 4"
6A	48785	Pump, RH	46	04050-02	Retaining Ring 3/4" External "E"
7	45464	Dump Valve, Lever Weldment	47	04019-02	Nut, 1/4-20 Serrated Flange Hex Head
8	421212	Mounting Bracket	48	04017-07	Cap Screw, 1/4-20 x 1-1/4" Serrated Flange Hex Head
9	04062-01	Hair Pin	49	04060-06	Roll Pin, 3/16 x 3/4"
10	04001-95	Hex Head Bolt, 5/16-18 x 5"	50	.	Hex Nut, 3/8-24
11	.	Flatwasher, 5/16"	51	.	Hex Head Bolt, 3/8-16 x 2"
12	.	Lockwasher, 5/16"	52	04041-12	Flatwasher, 3/8 x 1-1/2" x 16 ga.
13	.	Hex Nut, 5/16-18	53	48050	Spring, Brake Lever
14	45462	Pump Weldment Shaft	54	.	Carriage Bolt, 3/8-16 x 1-1/2"
15	421203	Clamp Plate	55	04019-04	Nut, 3/8-16 Serrated Flange Hex Head
16	48829	Block, Pump Control	56	04017-16	Cap Screw, 5/16-18 x 3/4" Serrated Flange Hex Head
17	48796	Bushing, Self Align	57	04062-02	Hair Pin, 1/16" diameter
18	421204	Bearing Bracket	58	.	Elastic Stop Nut, 1/4-20
19	.	Hex Head Bolt, 3/8-16 x 1"	59	48342	Grip, Parking Brake
20	.	Elastic Stop Nut, 3/8-16	60	.	Hex Head Bolt, 5/16-18 x 1-1/2"
21	.	Hex Head Bolt, 3/8-16 x 1-1/2"	61	04021-10	Elastic Stop Nut, 5/16-18
22	04041-07	Flatwasher, 3/8" Special	62	04041-08	Flatwasher, 3/4"
23	48544	Ball Joint, LH Thread	62A	04041-08S	Flatwasher, 3/4" Special
24	43246	Link, Tumbuckle	63	HG44612	Bolt, 1/4-20 x 2 1/2 GR. 5 w/patch
25	48464	Ball Joint, RH Thread	64	HG44276	Bolt, 1/4-20 x 1 1/2 GR. 5 w/patch
26	45460	Lever, Pump Transfer LH	65	HG44138	Bolt, Square Head
26A	45461	Lever, Pump Transfer RH	66	HG44127	Pins, Actuating
27	48114-04	Grease Fitting	67	HG44132	Brake Puck
28	48100-06	Bushing, LH	68	HG44134	Backing Plate
28A	48100-05	Bushing, RH	69	HG44094	Actuating Lever, RH
29	45435	Control Lever, LH	69A	HG44613	Actuating Lever, LH
29A	45436	Control Lever, RH	70	.	Cotter Pin
30	.	Hex Head Bolt, 5/16-18 x 1-1/2"	71	HG44142	Castle Nut
31	04019-03	Nut, 5/16-18 Serrated Flange Hex Head	72	HG44130	Washer
32	421145	Bar Control Lever	73	HG44090	Disc
33	45437	Control Handle	74	HG44143	Key, Woodruff Special
34	04017-27	Cap Screw, 3/8"-16 x 1", Serrated Flange Hex Head	75	HG23770	Spacer, Small
35	48093	Grip, Control Handle	76	HG23711	Spacer, Large
36	45482	Lever Weldment, Parking Brake	77	HG44092	Yoke Brake
37	45551	Cam Weldment, Parking Brake			
38	421262	Plate, Parking Brake			

* Common hardware which should be purchased locally. All bolts Grade 5 plated, all other fasteners zinc plated.

INSTRUMENT PANEL AND ELECTRICAL COMPONENTS

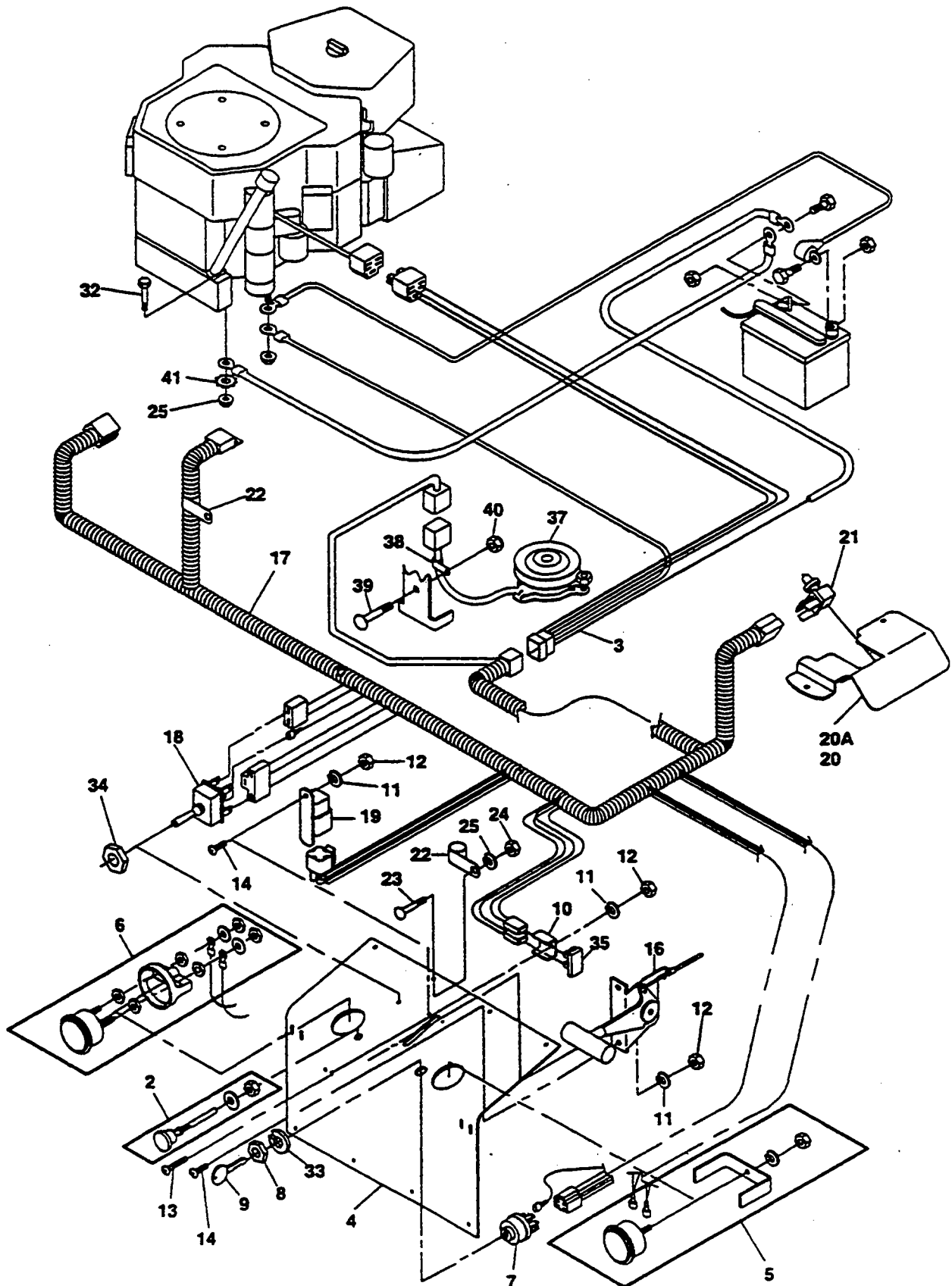

INSTRUMENT PANEL AND ELECTRICAL COMPONENTS

Ref. No.	Part Number	Description	20CV	22CV
1	48970	Engine 20 hp Kohler Command	X	
1	48972	Engine 22 hp Kohler Command		X
2	48780	Choke Control	X	X
3	48857	Adapter	X	X
4	421164	Kick Plate	X	X
5	48023	Hour Meter	X	X
6	48022	Ammeter	X	X
7	48798	Key Switch (Includes Mounting Hardware)	X	X
8	48017-04	Hex Nut, 5/8-32"	X	X
9	48017-02	Key & Ring Assembly	X	X
10	42413	Bracket, Fuse Holder	X	X
11	.	Lockwasher #10 External Tooth	X	X
12	.	Hex Nut #10-32	X	X
13	.	Screw, Phillips Washer Head #10-32 x 1-1/2"	X	X
14	.	Screw, Phillips Washer Head #10-32 x 1/2"	X	X
15	48015-01	Overflow Tube	X	X
16	48879	Throttle Control	X	X
17	48781	Wire Harness	X	X
18	48787	Switch, Mower Engagement Electric Clutch	X	X
19	48788	Relay	X	X
20	421253	Neutral Lock Bracket, RH	X	X
20A	421252	Neutral Lock Bracket, LH	X	X
21	48522	Switch Neutral Lock	X	X
22	48030-06	Clamp	X	X
23	.	Carriage Bolt, 5/16-18 x 1"	X	X
24	.	Elastic Stop Nut, 5/16-18	X	X
25	04019-03	Nut, 5/16-18 Serrated Flange Hex Head	X	X
26	48015	Battery	X	X
27	.	Hex Head Bolt, 1/4-20 x 1/2"	X	X
28	.	Nut, 1/4-20	X	X
29	48126	Rubber Boot	X	X
30	48029-13	Battery Cable, 25" Red		X
31	48029-11	Battery Cable, 27" Black	X	X
32	04047-19	Cap Screw, 5/16-18 x 1-3/4-1-1/2" Serrated Flange Hex Head	X	X
33	48017-03	Lockwasher, 5/8" Internal	X	X
34	48787-01	Hex Nut, 1/2-27	X	X
35	48298	Blade Type Fuse, 20 amp	X	X
36	04021-01	Elastic Stop Nut #10-32	X	X
37	48786	Electric Clutch	X	X
38	48030-09	Clamp	X	X
39	.	Carriage Bolt, 5/16-18 x 3/4"	X	X
40	04021-10	Elastic Stop Nut, 5/16-18	X	X
41	04031-09	Lockwasher, 5/16" Internal Tooth	X	X

* Common hardware which should be purchased locally. All bolts Grade 5 plated, all other fasteners zinc plated.

ELECTRICAL WIRING DIAGRAM - KOHLER ENGINE

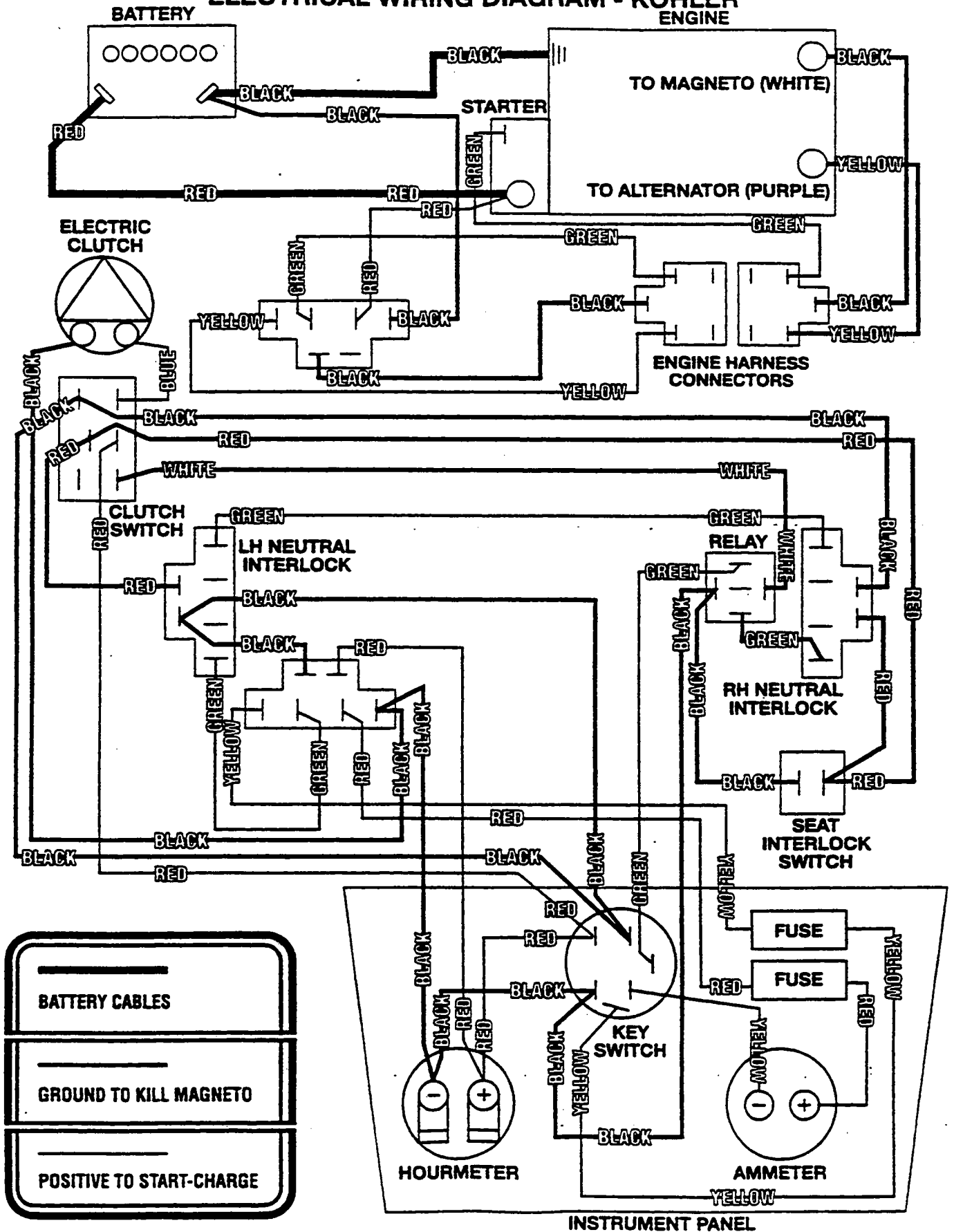

REPLACEMENT DECALS



48556 - Size 12" x 3.25"



48859 - Size 11.5" x 5.5"



48623 - Size 12" x 3.25"



48319-52
48320-61



48404



48825 - Size 8.5" x 2"



48072

IMPORTANT ADJUSTMENT PROCEDURES

READ OPERATOR'S MANUAL FOR MORE DETAILS

TRANSMISSION DRIVE BELT TENSION

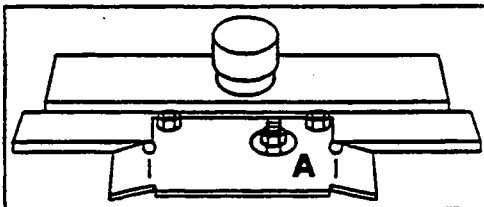

To adjust transmission drive belt tension, tighten or loosen nut (A) on J-hook connected to transmission drive idler. Under proper tension, belt should move 1/4" with 10 pounds of pressure. **IMPORTANT!** If drive belt is too tight, pump or belt failure is likely to occur.

FREE WHEEL OPERATION

To move machine without running the engine, locate dump valve lever under fender in front of left drive wheel. Unhook and push forward to free wheel. Pull lever back and rehook for normal operation.

STRAIGHT-LINE RUNNING OR TRACKING ADJUSTMENT

Before making adjustment, be sure both drive tires are inflated equally. Loosen nut (D) on LH pump linkage. If machine pulls to right, move forward in slot to slow left wheel. If machine pulls to left, move rearward in slot to speed up left wheel. Readjust neutral if necessary.

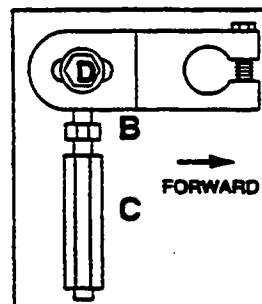

NEUTRAL ADJUSTMENT

Adjust neutral only with drive wheels elevated and machine blocked securely. Loosen jam nut (B) on the tumbuckle. If wheel rotates forward, adjust tumbuckle (C) clockwise. If wheel rotates rearward, adjust tumbuckle counter-clockwise. Adjust until drive wheel stops turning. Tighten jam nut.

HYDRAULIC FLUID LEVEL

Check hydraulic fluid level daily while fluid is cool. Fluid level should be 1/2" to 1" below bottom edge of fill sleeve. Fill with SAE 20W50 motor oil only.

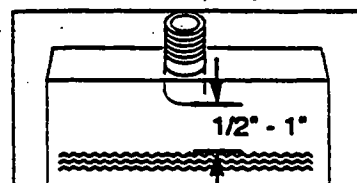

IMPORTANT! Do Not overfill. Room for hot fluid expansion must be allowed or resulting expansion may cause leaks in the system.

⚠ WARNING

INSTALL BELT COVERS BEFORE OPERATING MACHINE.

READ OPERATOR'S MANUAL

48824

REPLACEMENT DECALS

PARKING BRAKE
OFF

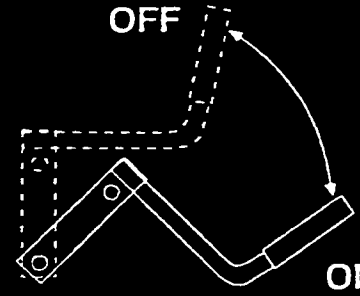

ON

CAUTION
AVOID INJURY FROM BURNS
SHUT OFF ENGINE BEFORE
REMOVING FUEL TANK CAP

• UNLEADED GASOLINE ONLY

48874

DANGER



SPINNING BLADE
KEEP CLEAR
CONTACT CAN INJURE

48071

WARNING

**INSTALL BELT COVERS BEFORE
OPERATING MACHINE**
READ OPERATOR'S MANUAL

48712

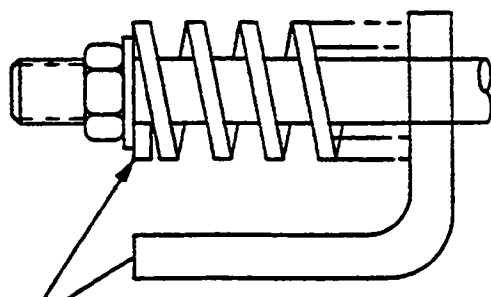

FOR CORRECT BELT TENSION
TIGHTEN NUT UNTIL SPRING
ALIGNS WITH BRACKET EDGE

SEE OPERATOR'S MANUAL

48873

WARNING

ROTATING BLADES AND BELTS

- KEEP HANDS, FEET & CLOTHING CLEAR
- KEEP ALL GUARDS IN PLACE
- SHUT OFF ENGINE & DISENGAGE BLADE CLUTCH BEFORE SERVICING
- CLEAN AREA OF DEBRIS BEFORE MOWING
- USE CAUTION IN DIRECTING DISCHARGE
- KEEP BYSTANDERS, CHILDREN & PETS AWAY
- READ INSTRUCTION MANUAL BEFORE OPERATING

DO NOT OPERATE WITHOUT DISCHARGE CHUTE, MULCHING KIT, OR ENTIRE GRASS CATCHER INSTALLED

48073

WARNING



PINCH POINT
KEEP HANDS
AND FEET AWAY

48715

START / DRIVE PROCEDURE

- ENGAGE PARKING BRAKE
- DISENGAGE MOWER DRIVE
- MOVE CONTROL HANDLES TO NEUTRAL LOCK POSITION
- START ENGINE
- RELEASE PARKING BRAKE
- SELECT FORWARD OR REVERSE SPEED WITH HYDRO CONTROL HANDLES

FAST

START STOP

SLOW

MOWER ON
PULL UP AND PUSH FORWARD TO ENGAGE

MOWER OFF
PULL BACK TO DISENGAGE

BEFORE OPERATING
READ OPERATOR'S
MANUAL AND SAFETY
INSTRUCTIONS

FORWARD

NEUTRAL

REVERSE

SCAG

48869