

SCAG®

HYDROSTATIC DRIVE COMMERCIAL MOWERS TECHNICAL MANUAL

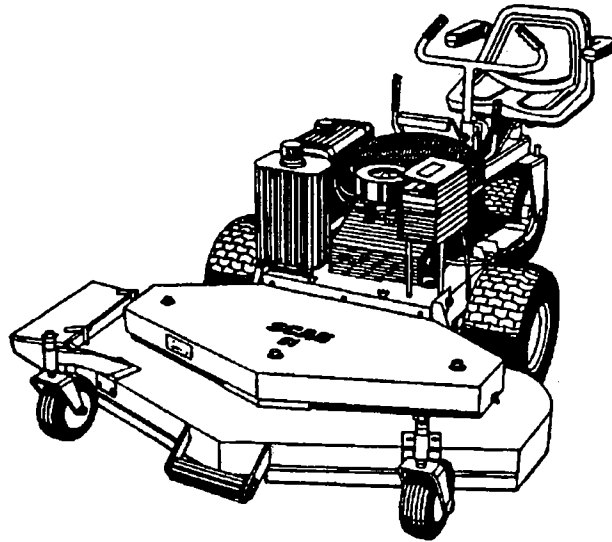

MODELS

STHM-20KH

SM-52

SM-61

SM-72

TABLE OF CONTENTS

SUBJECT	PAGE
Safety Instructions	1-2
Assembly Instructions	3-4
Adjustments	
Tire Pressures	4
Parking Brake	4
Neutral	5
Mower Belt Cam Link Over-Center	5
Hydro Drive Belt	6
Cutter Deck Drive Belt	6
Blade Drive Belt	6
Cutter Deck	6
Spindle Assembly	7
Operation and Initial Run-In	8
Maintenance	
Freewheel Position	8
Cutter Blades	8
Steering Cable Routing	8
Lubrication & Maintenance Chart	9
Illustrated Parts Listings	
SM-52	10-11
SM-61 & SM-72	12-13
Engine Deck	14-17
Instrument Panel	18-19
Rider Frame Assembly	20-22
Winch Lift System	23
Electrical System	24
Replacement Decals	25
Warranty	26

Your mower was built to the highest standards in the industry. However, your mower is only as safe as the operator. Carelessness or error on the part of the operator may result in serious bodily injury. Hazard control and accident prevention are dependent upon the awareness, concern, prudence, and proper training of the personnel involved in the operation, transport, maintenance, and storage of the equipment. Make sure every operator is properly trained and thoroughly familiar with all of the controls before operating the equipment.

SAFETY INSTRUCTIONS

1. Know the controls and how to stop quickly. READ THIS TECHNICAL MANUAL and instructions furnished with attachments. A replacement manual is available by sending complete model and serial number to:
SCAG Power Equipment, Inc.
1000 Metalcraft Drive
Mayville, WI 53050
2. Do not allow children to operate the machine. Do not allow adults to operate it without proper instruction.
3. Do not carry passengers. Do not mow when children and others are around.
4. Clear the work area of objects (wires, rocks, etc.) that might be picked up and thrown.
5. Disengage power to all attachments, do not depress foot pedal and engage parking brake before attempting to start the engine.
6. Disengage power to attachments and engage parking brake before leaving the operator's position.
7. Disengage power to attachments, stop the engine and remove key before making any repairs or adjustments.
8. Disengage power to attachments when transporting or not in use.
9. Take all possible precautions when leaving the machine unattended, such as disengaging the power-take-off, lowering the attachments, setting the parking brake, stopping the engine, and removing the key.
10. Do not operate machine while wearing sandals, tennis shoes, sneakers or shorts. Also, do not wear loose fitting clothing which could get caught in moving parts. Always wear long pants and substantial shoes. Wearing safety glasses and safety shoes is advisable and required by some local ordinances and insurance regulations.
11. Do not stop or start suddenly when going uphill or downhill. Mow up and down the face of steep slopes; never across the face.
12. Reduce speed and exercise extreme caution on slopes and in sharp turns to prevent tipping or loss of control. Be especially cautious when changing direction on slopes.
13. Stay alert for holes, rocks, and roots in the terrain and other hidden hazards. Keep away from drop-offs.
14. Use care when pulling loads or using heavy equipment.
 - a. Use only approved drawbar hitch points.
 - b. Limit loads to those you can safely control.
 - c. Do not turn sharply. Use care when backing.
 - d. Use counterweights or wheel weights when suggested in this technical manual.
15. Watch out for traffic when crossing or near roadways.
16. When using any attachments, never direct discharge of material toward bystanders nor allow anyone near the machine while in operation.
17. Handle gasoline with care - it is highly flammable.
 - a. Use approved gasoline container.
 - b. Never remove the fuel cap of, or add gasoline to, a running or hot engine or an engine that has not been allowed to cool for several minutes after running. Never fill the tank indoors and always clean up spilled gas.
 - c. Open doors if the engine is run in the garage- exhaust fumes are dangerous. Do not run the engine indoors.
18. Keep the machine and attachments in good operating condition, and keep safety devices and shields in place and in working condition.

19. Keep all nuts, bolts, and screws tight to be sure the equipment is in safe working condition.
20. Never store the equipment with gasoline in the tank inside a building where fumes may reach an open flame or spark. Allow the engine to cool before storing in any enclosure.
21. To reduce fire hazard, keep the engine free of grass, leaves or excessive lubricants.
22. The machine and attachments should be stopped and inspected for damage after striking a foreign object, and the damage should be repaired before restarting and operating the equipment.
23. Do not change the engine governor settings or overspeed the engine.
24. When using the machine with mower, proceed as follows:
 - a. Mow only in daylight or in good artificial light
 - b. Never make a cutting height adjustment while the engine is running
 - c. Shut the engine off and remove key when removing the grass catcher or unclogging chute.
 - d. Check the blade mounting bolts for proper tightness at frequent intervals.
25. Under normal usage, the grass catcher bag material is subject to deterioration and wear. Check bag frequently for deterioration and wear and replace worn bags. Check that replacement bags comply with the original manufacturer's recommendations or specifications.
26. Disengage power to mower before backing up. Do not mow in reverse unless absolutely necessary and then only after observation of the entire area behind the mower.
27. The discharge chute must be installed and in the down position on the side discharge mower except when optional grass catcher is completely installed. If the mower discharge ever plugs, shut engine off and wait for all movement to stop before removing obstruction.

28. Perform only those maintenance instructions described in this manual. If major repairs are ever needed or assistance is desired, contact an Authorized Scag Servicing Dealer. To ensure optimum performance and safety, always purchase genuine SCAG replacement parts and accessories. NEVER USE "WILL FIT" replacement parts and accessories made by another manufacturer. Use of unapproved replacement parts may void the warranty.

WARNING

DO NOT operate on steep slopes. To check a slope, attempt to back up (with cutter deck down). If machine can back up the slope without the wheels slipping reduce speed and use extreme caution.

HYDRAULIC SAFETY

- Safely relieve all pressure in the system before disconnecting the lines or performing work on the system.
- Keep body and hands away from pin holes or nozzles that eject hydraulic fluid under high pressure. Use paper or cardboard and not hands to search for leaks.
- Hydraulic fluid escaping under high pressure may have sufficient force to penetrate skin and cause serious injury. If foreign fluid is injected into the the skin, it must be surgically removed within a few hours by a doctor familiar with this form of injury or gangrene may result.
- Make sure all hydraulic fluid connections are tight and all hydraulic hoses and lines are in good condition before applying pressure to the system.

ASSEMBLY INSTRUCTIONS

1. Remove all crating and packing materials. Layout loose mounting hardware according to the "Where Used" as listed in the hardware package contents.
2. Remove battery from battery support.

⚠ WARNING: Severe chemical burns can result from improper handling of battery electrolyte. Use proper eye, skin and clothing protection to prevent contact with eyes, skin and clothing.
 External contact: Flush with water.
 Internal contact: Drink large quantities of water, followed with milk of magnesia, beaten egg or vegetable oil. **CALL A PHYSICIAN IMMEDIATELY!**
IMPORTANT - In case of internal contact DO NOT give fluids that would induce vomiting.
 Eye contact: Flush with water for at least 15 minutes and get medical attention immediately!

⚠ WARNING: Explosive gases are vented from a battery when being charged or discharged which could explode if exposed to a flame or spark.

Fill with electrolyte solution.
 Charge at 3 to 5 amps for about 2 hours.
 Check fluid level and add electrolyte until level is up to the bottom of the split ring.
NOTE: Future need to adjust fluid level requires distilled water.
 Wash and dry off battery. Coat terminals with grease to minimize corrosion.

3. Attach the seat assembly to the seat support spring using two 3/8-16 x 1" bolts and lock washers. The seat and/or spring may be positioned forward or back for operator comfort.
4. Attach arm rests to seat back and use setscrews to adjust arm rests so they are horizontal. Tighten setscrews until tight and then back off 1/4 to 1/2 turn.
5. Slide steering handle on to shaft and secure with one 5/16-18 x 1-1/2" bolt, two flat washers, and a lock nut. Tighten securely.
6. Set the cutter deck on blocks about 2" off of a level floor. Remove the belt cover and control rod. Determine what height of cut is needed before attaching the cutter deck to the engine deck (See fig.1).
7. Move the tractor assembly to the cutter deck assembly. Loosen the winch cable and tilt the engine deck to a horizontal position. Align the holes and insert drift pins to assist in assembly.

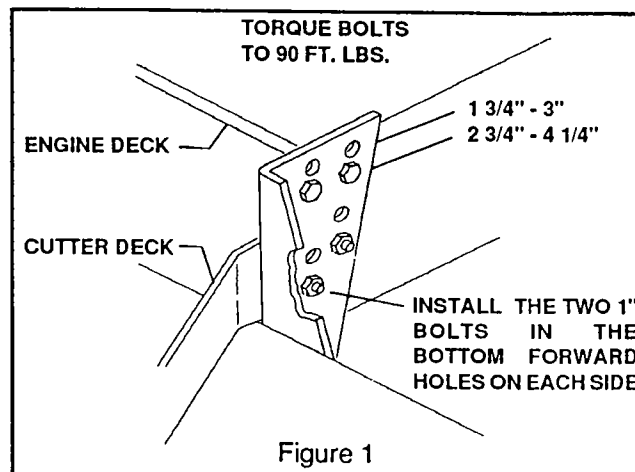

NOTE: The two lower front bolts on the left hand side must be installed with the nut, lock washer, and flat washer on the outside. Secure together using six 1/2-13 x 1-1/2" bolts, two 1/2-13x1" bolts, flat washers, lock washers, and hex nuts. **Tighten all eight bolts to 90 ft. lbs. then go back and retorquing each one.**

8. Raise the cutter deck using the winch and attach each front caster wheel using four 5/16-18 x 3/4" bolts, lock washers, and hex nuts.
NOTE: If installing a 72" cutter deck, remove ballast from cutter deck and install under seat prior to raising cutter deck. (See fig. 2)

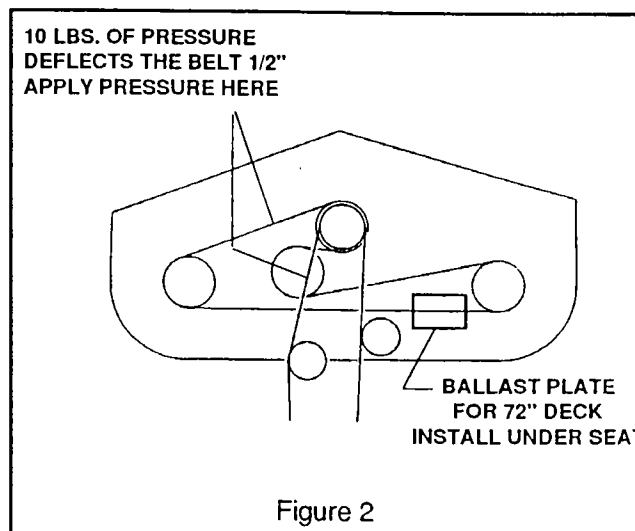

9. Install the mower engagement control rod, to the mower engagement lever arm located under the engine deck and to the over-center mechanism in the front, with hair pin cotters.
10. Route the blade drive belt around the engine pulley and the cutter deck pulleys.

ASSEMBLY INSTRUCTIONS CONT'D

11. Push the mower engagement lever forward until the over-center mechanism snaps into place. Check the over-center spacing as shown in figure 7. Check belt guide, adjust if necessary. Adjust belt tension as shown in figure 2 after over-center spacing is set. Reinstall belt cover.

! NEVER engage cutter deck without belt cover in place!!

12. Attach the discharge chute to the cutter deck using two 5/16-18 x 1" bolts and elastic stop nuts. Tighten only enough to remove excessive end play. Discharge chute must be free to move up and down.
13. Install battery into the battery support, connect the positive cable to the positive terminal and cover with the boot, then attach the negative cable. Install the battery box cover and tighten the wing nuts finger tight.
14. Check engine oil level, add as necessary (unit was filled with 30W motor oil at the factory).
15. Check hydrostatic oil reservoir, oil should be 3" from the top of the reservoir. (See fig. 3)
!DO NOT OVER FILL!
Add SAE 10W30 motor oil if necessary.

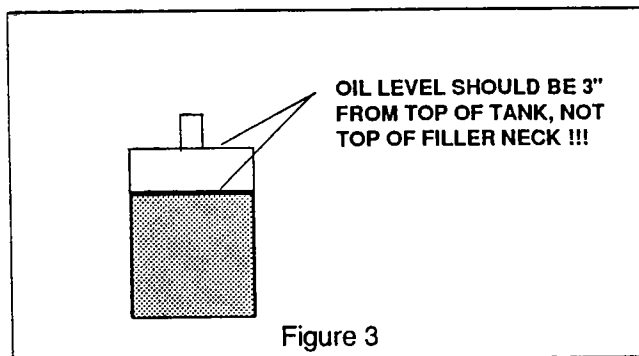

16. Check bolts for proper tightness.
17. Fill fuel tank with gasoline.
18. Open shut-off valve under tank.

ADJUSTMENTS

Tire Pressures

Caster Wheels	25 PSI
Rear Steering Wheel	25 PSI
Drive Wheels	15 PSI

Parking Brake

Adjust the nuts on the cable, so that the wheels are locked when the parking brake is in the engaged position. Parking brake should be completely released when in disengaged position. Drive wheels should "slide" rather than "roll" when brake is engaged. The pivot spring is adjusted so that the handle just clears the side edge of the instrument panel. (See fig. 4)

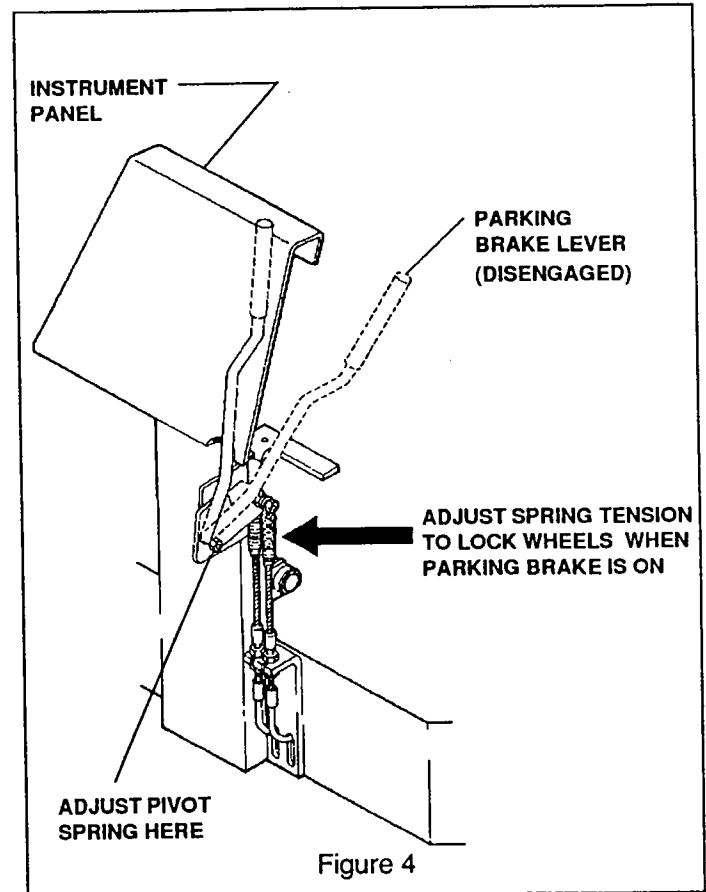

ADJUSTMENTS CONT'D

Neutral Adjustment

Note: If hydraulic components (pump, motors, hoses, etc.) are replaced, all air **must** be bled from system prior to making neutral adjustment.

1. Set the engine deck up on jack stands, so the wheels are free to rotate. Block caster wheels to prevent an accident should the unit fall off the jack stands.
2. Start engine and determine if the drive wheels rotate.

If drive wheels **consistently** rotate when foot pedal control is in neutral, go to step 3.

If drive wheels **inconsistently** rotate; ie. drive wheels sometimes rotate and sometimes do not when foot pedal is not depressed then check neutral adjustment bolt for "zero free play" in neutral control spring. (See fig. 5) To do this, shut off engine. Tighten nut on neutral adjustment bolt until all free play is removed between bolt and spring (fore & aft). **Do not over tighten.** If you turn nut to much you will compress spring, making too much end play. Go to step 3.

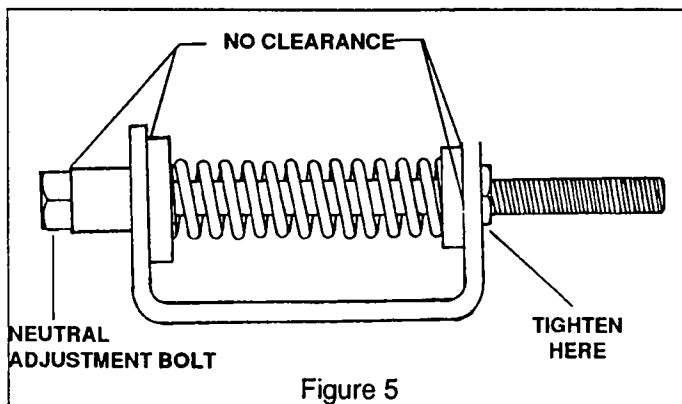

Figure 5

3. If drive wheels rotate in forward travel direction, turn adjustment bolt clockwise until rotation stops. If drive wheels rotate in rearward travel direction, turn adjustment bolt counter-clockwise until rotation stops.
4. Check adjustments of foot control pedal for full forward speed. Pedal should rest on foot plate when pump is stroked in full forward position. To make adjustment, disconnect ball joint from pedal arm and loosen jam nut. (See fig. 6) Place foot control pedal forward against foot rest and adjust ball joint on rod until stud aligns with hole in arm. Bolt ball joint to arm and tighten jam nut.

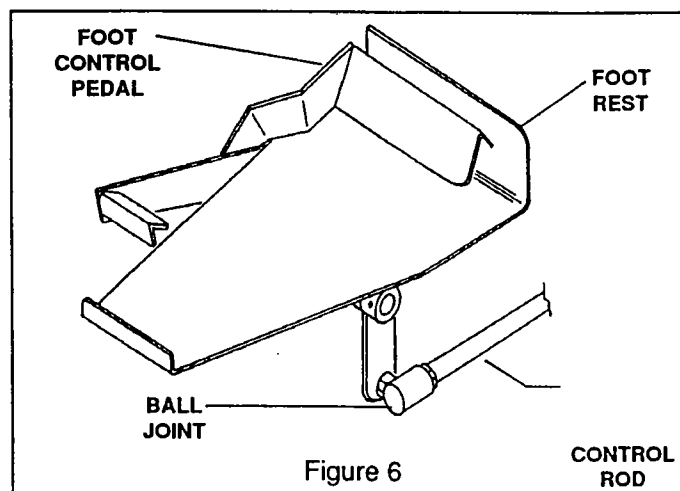

Figure 6

5. Start engine. Wheels should rotate only when foot control pedal is depressed.

Mower Belt Cam Link Over-Center Adjustment

The over-center adjustment must be checked and adjusted before setting the belt tension.

Engage the blade clutch lever and check for proper over-centering. There should be about 3/8" between rod and straight edge (See fig. 7). Bend the stop tab to adjust the clearance.

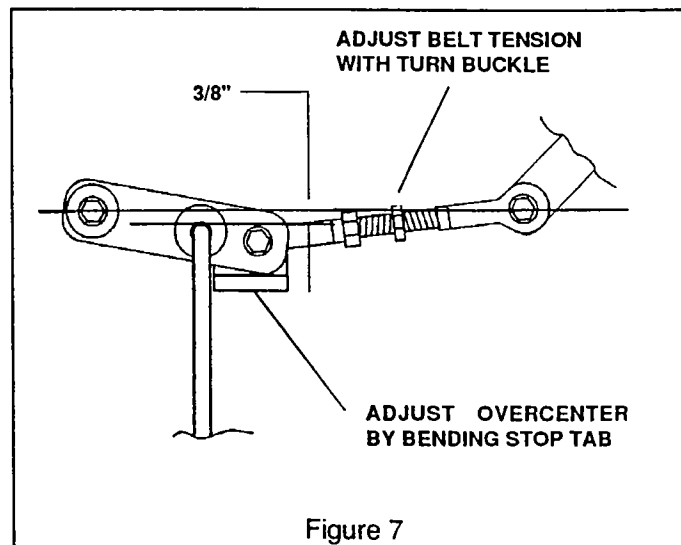

Figure 7

Belt Alignment Adjustment

Align belt horizontally between the center spindle pulley and engine pulley. Remove or install the spacer located under the stationary idler bracket to get belt and pulley alignment, on 61" and 72" decks.

ADJUSTMENTS CONT'D

Belt Tension

Hydro Drive Belt

This belt is spring loaded and does not require adjustment.

Cutter Deck Drive Belt

Belt tension should not be adjusted until over-center spacing is checked. Adjust the belt tension so that the b moves 1/2" with 10 pounds of pressure (See fig. 2). Adjustment is made by loosening the wing nut and tightening or loosening the turnbuckle.

Blade Drive Belt

Adjust the belt tension so that the belt moves 1/2" with 10 lbs. of pressure. Adjust tension by tightening or loosening the "J"-bolt.

Cutter Deck Adjustments

Due to the many conditions that exist, it is difficult to suggest a setting that will work for every lawn. There are two adjustments that can be made on these decks, pitch and height.

PITCH is the angle of the blades (comparing front to rear). A *positive pitch* is when the front (leading) edge of the cutting plane is lower than the rear (trailing) edge, *level pitch* is when both front and rear are basically level, a *negative pitch* is when the leading edge is higher than the rear edge.

HEIGHT is the nominal distance the blade is off of the ground (this measurement is made with the blades pointed side to side and distance is measured between cutting tip and ground). Adjusting the blade height can be done by moving any number of the five spacers on the blade mounting bolts to the top of the spindle shaft or below the spindle shaft (all blades should be positioned equally). Unit is shipped with one spacer on top and four underneath (see fig. 8 & 9). This adjustment does not effect blade pitch.

For best results, keep the cutter deck high in relation to the engine deck and the blades low in the cutter deck; ie. 3,4,5 spacers below the spindle shaft.

Additional range to the cutting height can be achieved by repositioning the cutter deck in relationship to the engine deck (This adjustment also affects the pitch of the deck). There are 2 positions (see fig. 1), suggested mounting is the bottom hole. For cutting lower, mount the cutter deck in the upper hole which drops the deck down. Check the cutter deck belt alignment after repositioning it.

Caster spacers also can be repositioned to change cutting heights and to change the pitch of the deck (see fig. 10).

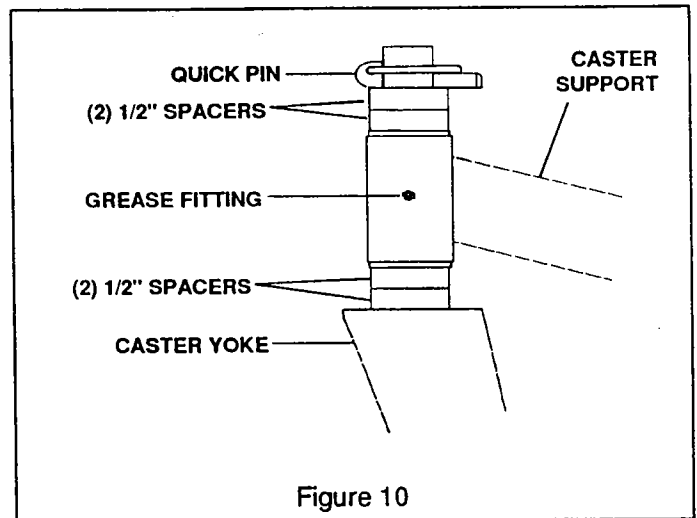
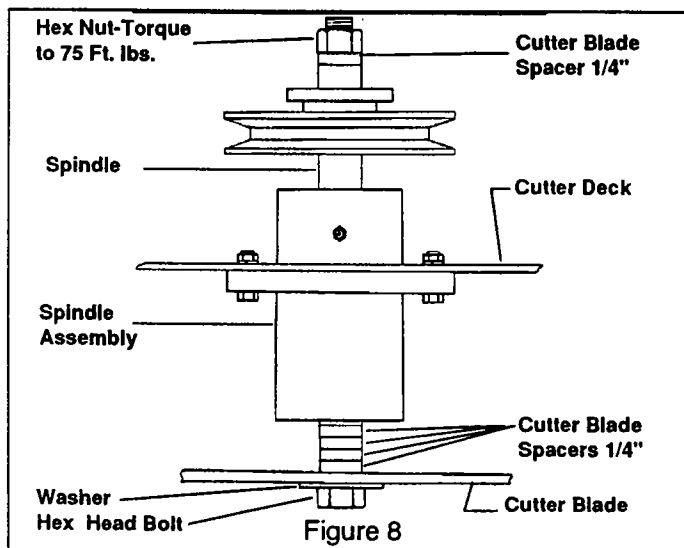

Figure 10

ADJUSTMENTS CONT'D

BALL BEARING SPINDLE ASSEMBLY

Adjusting the blade height can be done by moving any number of the five spacers on the blade mounting bolts to the top of the spindle shaft or below the spindle shaft (all blades should be positioned equally). Unit is shipped with one spacer on top and four underneath (see figure 9). For best cut and discharge a minimum of three spacer should be between the blade and spindle.



TAPERED BEARING SPINDLE ASSEMBLY

Adjusting the blade height can be done by moving any number of the four smaller 1/4" spacers on the blade mounting bolts to the top of the spindle shaft or below the spindle shaft. (All blades should be positioned equally). The tapered bearing spindle has a large 1/4" spacer that is installed directly below the spindle housing and is secured to the spindle with two roll pins. The blade can be adjusted all the way up to the spindle assembly if all the smaller 1/4" spacers are removed and installed above the pulley. The larger 1/4" spacer can then be removed along with the roll pins. (Do not install the larger 1/4" spacer above the pulley, store it in a convenient location away from the machine). When any 1/4" spacers are installed above the blades the larger 1/4" spacer must be installed directly below the spindle housing. If a smaller 1/4" spacer is installed directly below the spindle housing and contacts the retaining ring this will cause a spindle failure and not be warrantable. For best cut and discharge a minimum of three spacers should be between the blade and spindle. (SEE FIGURE 10)

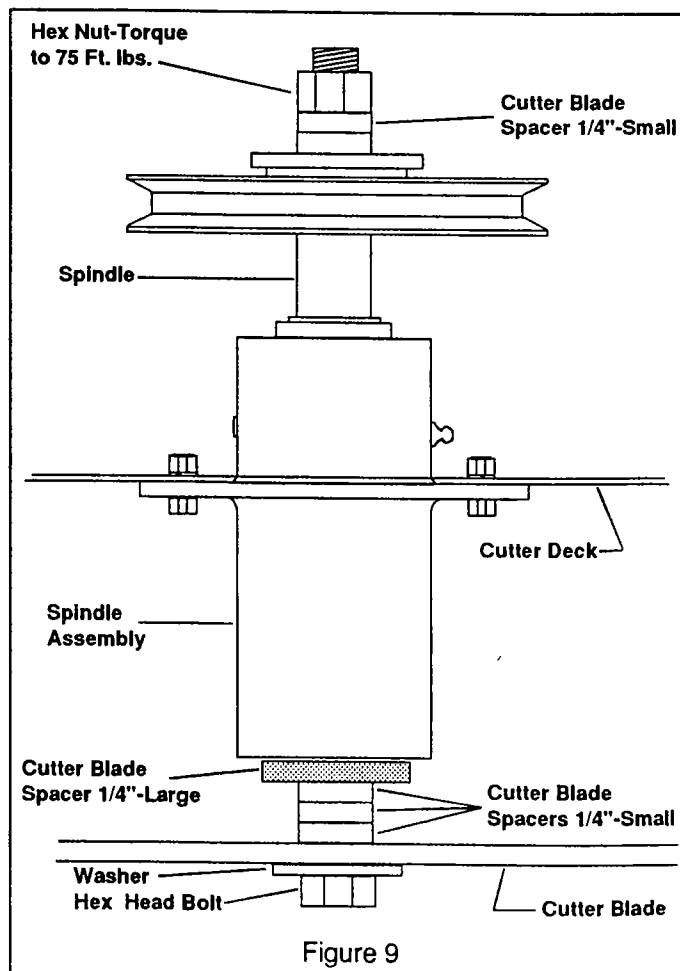

OPERATION AND INITIAL RUN-IN

1. Check for correct routing of belts and for correct clearance of belt guides.
2. Check for correct alignment and initial tension of cutter blade drive belts.
3. Check that all fasteners are correctly tightened.
4. Check oil levels in engine and hydraulic reservoir.
5. Fill fuel tank with clean fresh lead free gasoline.
6. To start engine:
Pull mower engagement lever to off position.
Depress the left foot (operator presence) pedal.
Put parking brake in engaged position.
Adjust throttle and choke as required.
Do not depress hydro foot pedal.
Turn ignition key to start.
7. To engage blades release the parking brake. Observe to see that the unit does not creep forward or backwards. If it does creep, adjust hydro neutral control as specified in adjustment section.
8. Release the parking brake. Push mower engagement lever forward until over-center snaps into the engaged position. At initial run in allow belts to run-in for 5 minutes.
9. To operate the unit forwards and backwards, depress right foot pedal at the toe end to make the machine drive forward, depress the right foot pedal at the heel end to make the machine drive in reverse. Check that all systems function correctly.
10. Shut off engine and recheck cutter deck drive belts for proper tension, and any signs of rubbing. Correct and adjust as necessary.

Freewheel Position

To move machine around without having the engine running, rotate dump valve lever located on the left hand side of the pump approximately 1/2 turn. **Lever must be returned to original position in order to operate machine.**

MAINTENANCE

Cutter Blades

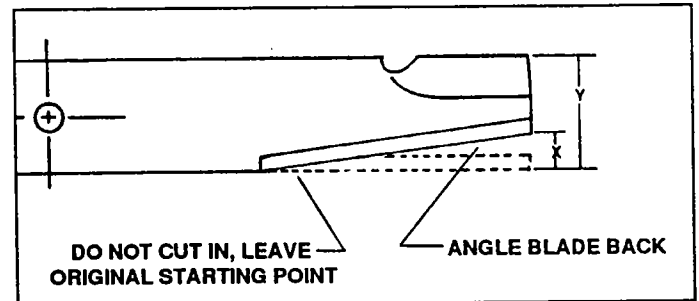

Do not sharpen (X) beyond 1/3 of the width (Y) of the blade.

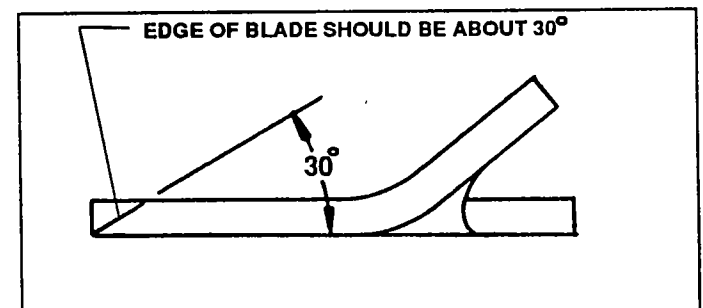

Suggestion: Dress the blade with a file. Using a wheel grinder may burn the blade.

Steering Cable Routing

When the steering cable is routed between the front pulley and the rear steering collar, it is very important that the cable does not rub where it crosses. The top of the cable end from the front pulley must go over the top of the lower cable end. (See fig. 10) Cable should be tightened until the slackness has been removed. Cable should **not** be under tension.

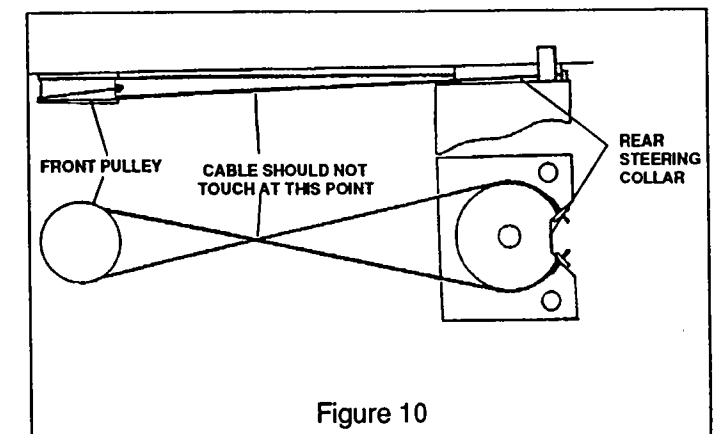

Figure 10

LUBRICATION & MAINTENANCE

		Break-In	8 Hours (Daily)	40 Hours (Weekly)	100 Hours (Biweekly)	200 Hours (Monthly)	PROCEDURE	COMMENTS
X	X	X					Check all hardware for proper tightness Change engine oil and filter at 5 hours Change hydrostatic oil filter at 20 hours	Adjust oil level as needed - SAE 10W30
X	X	X	X	X	X	X	Check engine oil Clean blower screen Remove debris from under belt cover Sharpen cutter blades Grease spindle bearings 2 pumps of hand gun Clean air filter	Do not over fill MORE OFTEN IF NEEDED * * * * * + US Lithium MP White Grease 2125 MORE OFTEN IF NEEDED
X	X	X	X	X	X	X	Check battery acid level Check tire pressure Replace air filter - qualify Change engine oil - qualify	Distilled water only Add or adjust as required MORE OFTEN IF NEEDED MORE OFTEN IF NEEDED
X	X	X	X	X	X	X	Grease caster wheel bearings Grease caster wheel pivots Grease idler arm pivots	Chassis grease Chassis grease Chassis grease
X	X	X	X	X	X	X	Check all hardware for proper tightness Change engine oil filter Check hydro fluid reservoir level Clean and Adjust spark plugs Grease rider frame pivot Grease control bell cranks Grease steering handle bearing Grease foot pedal bearings Grease rear wheel pivot vertical Grease rear wheel bearing	See engine mfg. information See engine mfg. information Chassis grease Chassis grease Chassis grease Chassis grease Chassis grease + US Lithium MP White Grease 2125
							Every 500 hours Drain Hydraulic System and replace fluid Change hydrostatic oil filter	Use SAE 10W30 motor oil Clean area before removing filter

- * Depending on climate and environment, lubrication may be required every 8 to 40 hours.
- * Do not over grease as this may damage seal.
- + Compatible Greases:
 - Lidok EP #2 found at industrial shops
 - Ronex MP found at Exxon Service Stations
 - Shell Alvania #2 found at Shell Service Stations
 - Mobilux #2 found at Mobil Service Stations
 - Super Lube M EP #2 and Super Stay-M #2 found at Conoco Service Stations

SM-52 CUTTER DECK

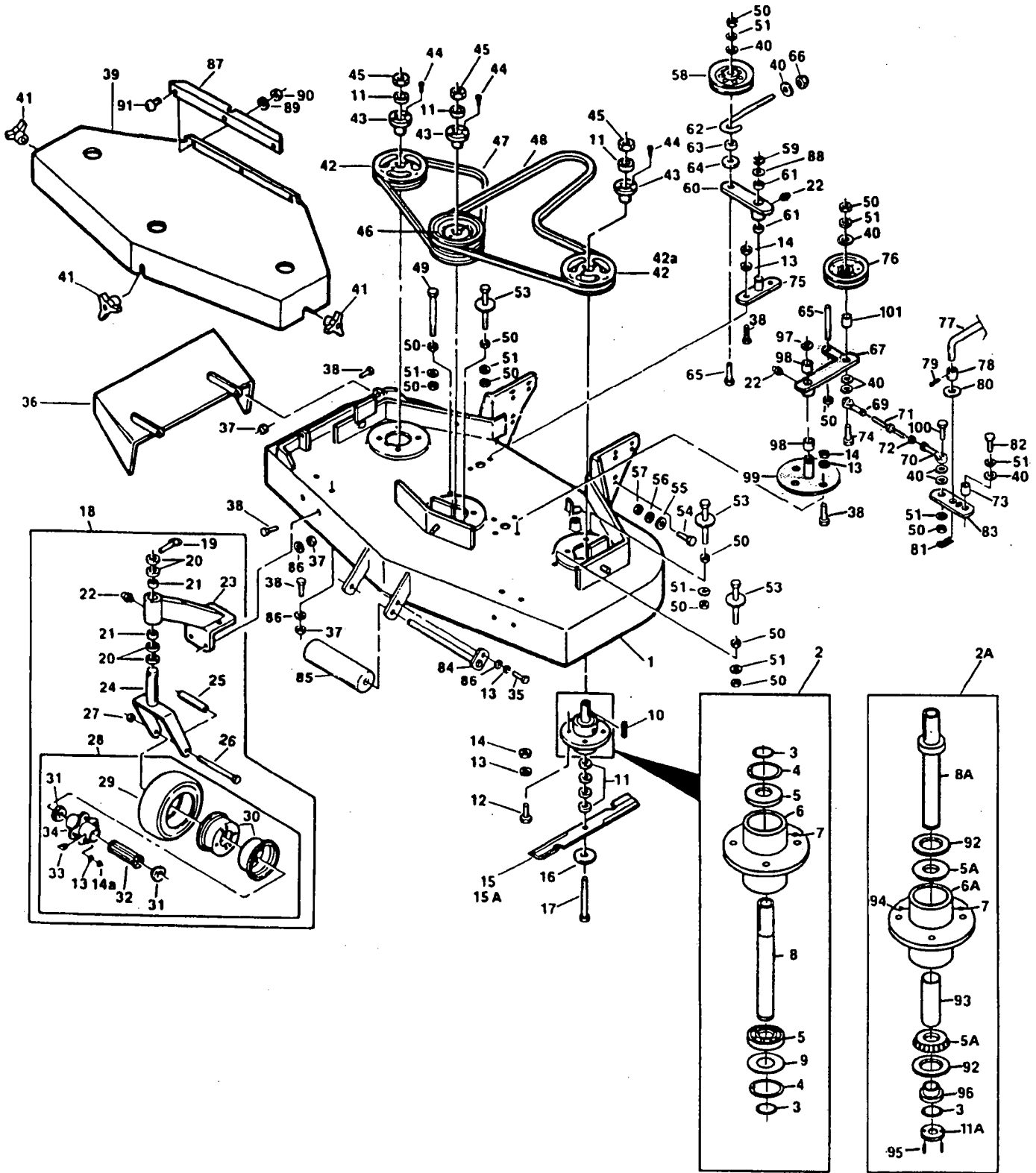

SM-52 CUTTER DECK

Ref. Part No.	Part Number	Description	Ref. Part No.	Part Number	Description
1	46318	Cutter Deck (Includes decals)	48	48530	Belt, Blade Drive
2	46020	Cutter Spindle Assy. (Includes 3-9)	49	*	Hex Head Bolt, 3/8-16 x 5
2A	46400	Spindle Assembly, Tapered Bearing	50	*	Hex Nut, 3/8-16
3	04050-04	Retaining Ring, 1" Ext.-Inverted	51	*	Lockwasher, 3/8 Spring
4	04050-07	Retaining Ring, 2-7/16 Int.-Basic	53	45098	Belt Guide
5	48101-02	Bearing, Cutter Spindle	54	*	Hex Hd. Bolt, 1/2-13 x 1-1/4
5A	48668	Tapered Bearing	54	*	Hex Hd. Bolt, 1/2-13 x 1-1/2
6	41001	Spindle Housing	55	*	Flat Washer, 1/2
6A	41007	Spindle Housing, Tapered Bearing	56	*	Lockwasher, 1/2
7	48114-02	Grease Fitting, Str. 5/16 Serr.	57	*	Hex Nut, 1/2-13 Elastic Stop
8	43001-02	Spindle, Cutter Blade	58	48181	Pulley
8A	45391	Spindle Shaft, Tapered Bearing	59	04050-02	Retaining Ring, 3/4" Ext. - "E"
9	04041-02	Washer, 1-15/16 x 2-13/32 x 16 ga.	60	46081	Idler Arm Assembly (Includes 22 & 61)
10	04063-08	Key, 1/4 x 1/4 x 2	61	48100-05	Bronze Bearing
11	43038	Spacer, Cutter Blade	62	43028	J.Rod, Idler Pulley
11A	43201	Spacer, Cutter Blade	63	43077	Spacer
12	*	Hex Head Bolt, 5/16-18 x 1-1/4	64	04041-12	Washer, 3/8 x 1-1/2 x 16 ga.
13	*	Lockwasher, Spring, 5/16	65	04004-04	Stud
14	*	Hex Nut, 5/16-18	66	*	Hex Nut, 3/8-16 Elastic Stop
15	48108	Cutter Blade, 18" Std.	67	46434	Idler Arm (incl. 22 & 98) — 46145
15a	48185	Cutter Blade, 18" Hi Lift	68	*	Flat Washer, 3/8"
16	04040-10	Flat Washer, 5/8	69	48544	Rod End LH THD (Silver) — 04070-C1
17	04001-41	Hex Head Bolt, 5/8-11 x 9-1/2	70	48464	Rod End RH THD (Gold) — 04070-02
18	46079	Caster Assy, Complete (Includes 19-28)	71	48590	Link, Turnbuckle
19	04066-01	Quick Pin	72	*	Hex Nut, 3/8-24 — 43025
20	43037-01	Spacer, Caster Yoke, 1/2 Long	73	43042	Sleeve, Cam Clutch
21	48100-01	Bronze Bearing	74	*	Hex Head Bolt, 3/8-16 x 3 1/4"
22	48114-04	Grease Fitting, Str. 1/4-28	75	45037	Idler Pivot
23	46082	Support Assy. (Includes 21-22)	76	48269	Pulley, Idler
24	45006	Caster Yoke	77	44054	Blade Clutch Rod
25	43022	Sleeve, Caster Wheel Bearing	78	43043	Sleeve, Clutch Rod
26	04001-37	Hex Head Bolt, 1/2-13 x 5-1/2	79	*	Cotter Pin, 3/32 x 1
27	*	Hex Locknut, 1/2-13	80	*	Flat Washer, 33/64 x 1 x 16 ga.
28	48307-01	Wheel Assy. (Includes 13-14, 14a, 29-34)	81	04062-01	Hair Pin, Large
29	48307-02	Tire Only, Caster Wheel	82	*	Hex Hd. Bolt, 3/8-16 x 1
29a	48006-03	Inner Tube Only, Caster Wheel	83	421107	Cam Link — 42057
30	48307-04	Rim Pair, Caster Wheel	84	45046	Roller Shaft
31	48006-07	Retainer, Bearing, Caster Wheel	85	48038	Guide Roller
32	48006-06	Roller Bearing, Caster Wheel	86	*	Flat Washer, 5/16
33	48114-03	Grease Fitting, 45° 1/4-28	87	42045	Belt Cover Skirt
34	48006-05	Hub Assy. w/Bolts, Caster Wheel	88	04041-085	Flat Washer, 49/64 x 1-1/4 x 16 ga.
35	*	Hex Head Bolt, 5/16-18 x 3/4	89	*	Lockwasher, 1/4
36	45100	Discharge Chute	90	*	Hex Nut, 1/4-20
37	*	Hex Nut, 5/16-18 Elastic Stop	91	*	Machine Screw, 1/4-20 x 1/2 Slit Truss Hd
38	*	Hex Head Bolt, 5/16-18 x 1	92	48681	Seal, Tapered Bearing Spindle
39	46319	Belt Cover (Includes decals)	93	43218	Sleeve, Cutter Spindle
40	*	Flat Washer, 25/64 x 15/16 x 12ga.	94	48677	Relief Fitting, Cutter Spindle
41	04029-03	Wing Nut, 3/8-16	95	*	Roll Pin, 1/8 x 1/2"
42	48127	Pulley (Includes 43-44)	96	43217	Spindle Bushing
43	48141	Taper Hub	97	04050-05	Retaining Ring, 1 1/8" Ext. - "E"
44	*	Hex Hd. Bolt, 1/4-20 x 3/4	98	48100-02	Bronze Bearing
45	*	Hex Nut, 5/8-11	99	45329	Idler Pivot — 45037
46	48412	Pulley, Double (Includes 43-44)	100	*	Hex Head Bolt, 3/8-16 x 1 1/2"
47	48285	Belt, RH Blade Drive	101	43077	Spacer

* Common hardware which should be purchased locally. All bolts Grade 5 plated, all other fasteners zinc plate.

SM-61 & SM-72 CUTTER DECK

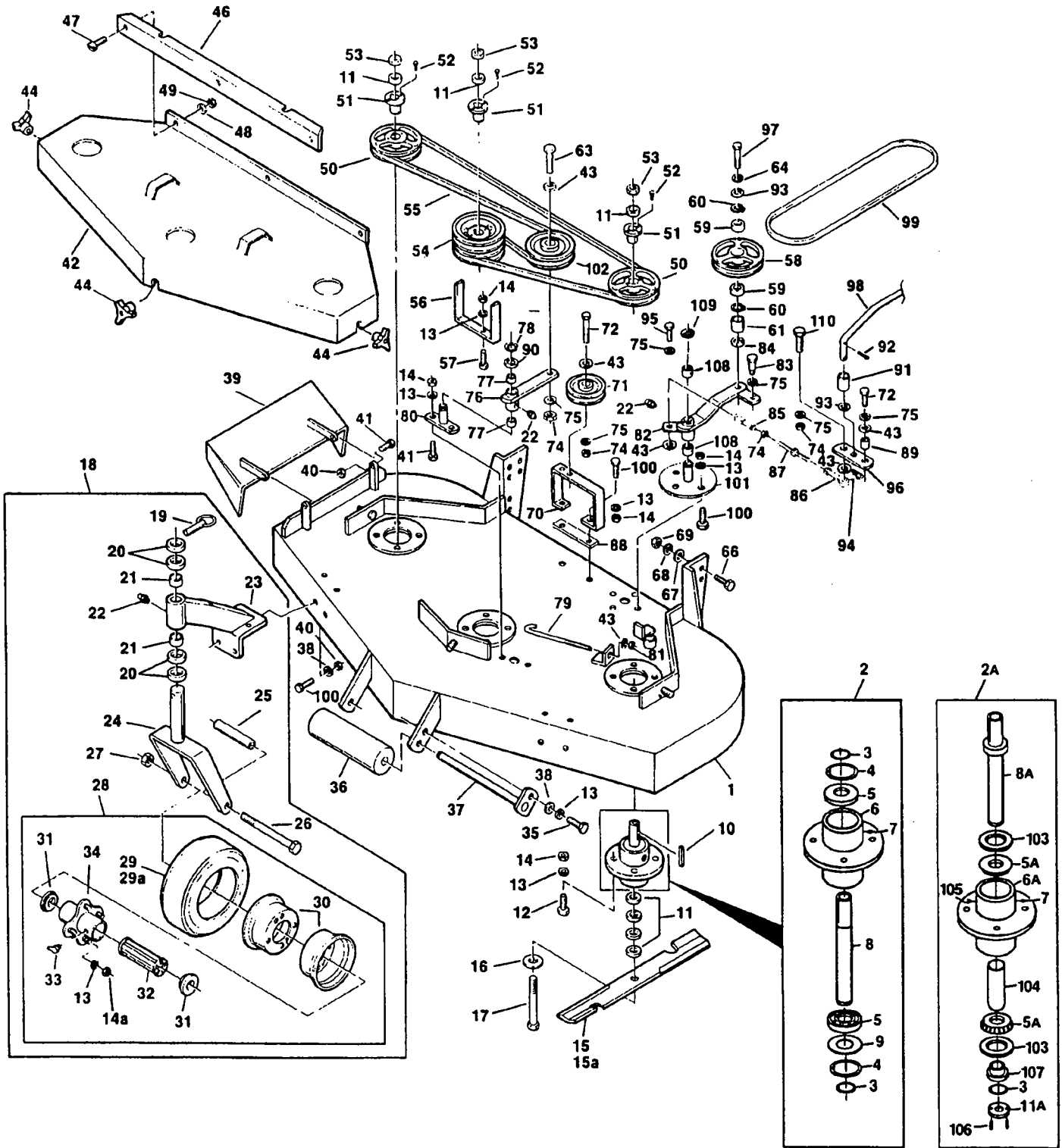

SM-61 & SM-72 CUTTER DECK

Ref. Part No.	Part No.	Description	SM 61	SM 72	Ref. Part No.	Part No.	Description	SM 61	SM 72
1	46150	Cutter Deck (incl. Decal)	x		52	*	Bolt, Hex Hd., 1/4-20 x 3/4	x	x
1	46245	Cutter Deck (incl. Decal)		x	53	*	Hex Nut, 5/8-11	x	x
2	46020	Cutter Spindle Assy. (incl. 3-9)	x	x	54	48128	Pulley, Double (includes 51-52)	x	
2A	46400	Spindle Assembly, Tapered Bearing	x	x	54	48302	Pulley, Double (incl. 51-52)		x
3	04050-04	Retaining Ring, 1" Ext. Inverted	x	x	55	48607	Belt, Blade Drive	x	
4	04050-07	Retaining Ring, 2-7/16 Int. Basic	x	x	55	48608	Belt, Blade Drive		x
5	48101-02	Bearing, Cutter Spindle	x	x	56	42063	Belt Guide	x	
5A	48668	Tapered Bearing	x	x	56	*	Bolt, Hex Hd., 3/8-16 x 5		x
6	41001	Spindle Housing	x	x	57	*	Bolt, Hex Hd., 5/16-18 x 1-1/2	x	x
6A	41007	Spindle Housing, Tapered Bearing	x	x	58	48062	Pulley Idler	x	x
7	48114-02	Grease Fitting, Str. 5/16 Serr.	x	x	59	48102	Bearing	x	x
8	43001-02	Spindle, Cutter Blade	x	x	60	04050-06	Retaining Ring, 1-9/16 Int. Basic	x	x
8A	45391	Spindle Shaft, Tapered Bearing	x	x	61	43045	Sleeve, Idler Bearing	x	x
9	04041-02	Washer, 1-5/16 x 2-7/16 x 16 ga.	x	x	62	43040	Spacer, Idler Bearing	x	x
10	04063-08	Key, 1/4 x 1/4 x 2	x	x	63	*	Bolt, Hex Hd., 3/8-16 x 2-3/4	x	x
11	43038	Spacer, Cutter Blade	x	x	64	*	Lockwasher, Spring 1/2	x	x
11A	43201	Spacer, Cutter Blade	x	x	66	*	Bolt, Hex Hd., 1/2-13 x 1-1/4	x	x
12	*	Bolt, Hex Hd., 5/16-18 x 1-1/4	x	x	66	*	Bolt, Hex Hd., 1/2-13 x 1-1/2	x	x
13	*	Lockwasher, Spring, 5/16	x	x	67	*	Flat Washer, 1/2	x	x
14	*	Hex Nut, 5/16-18	x	x	68	*	Lockwasher, 1/2	x	x
14A	*	Hex Nut, 5/16-24	x	x	69	*	Hex Nut, 1/2-13, Elastic Stop	x	x
15	48111	Cutter Blade, 21" Std.	x		70	42536	Idler Pulley Support	x	x
15	48112	Cutter Blade, 24" Std.		x	71	48413	Pulley, Belt Guide	x	x
15A	48304	Cutter Blade, 21" High Lift	x		72	*	Bolt, Hex Hd., 3/8-16 x 2	x	x
16	04040-10	Flat Washer, 5/8W	x	x	74	*	Hex Nut, 3/8-16	x	x
17	04001-41	Bolt, Hex Hd., 5/8-11 x 9-1/2	x	x	75	*	Lockwasher, Spring, 3/8	x	x
18	46079	Caster Assy. Comp. (incl. 19-28)	x	x	76	46081	Idler Arm Assy. (incl. 22 & 77)	x	x
19	04066-01	Quick Pin	x	x	77	48100-05	Bronze Bearing	x	x
20	43037-01	Spacer, Caster Yoke, 1/2 Long	x	x	78	04050-02	Retaining Ring, 3/4 Ext. "E"	x	x
21	48100-01	Bronze Bearing	x	x	79	43028	Rod, Idler Pull, J	x	x
22	48114-04	Grease Fitting, Str. 1/4-28	x	x	80	45037	Idler Pivot	x	x
23	46082	Support Assy. (incl. 21-22)	x	x	81	*	Hex Nut, 3/8-16 Elastic Stop	x	x
24	45006	Caster Yoke	x	x	82	46383	Idler Arm Assy. (incl. 22 & 77)	x	x
25	43022	Sleeve, Caster Wheel Bearing	x	x	83	43054	Shoulder Bolt	x	x
26	04001-37	Bolt, Hex Hd., 1/2-13 x 5-1/2	x	x	84	43041	Spacer, Idler	x	x
27	*	Hex Locknut, 1/2-13	x	x	85	48544	Rod End, LH (gold colored)	x	x
28	48307-01	Wheel Assy. (Incl. 13-14, 14a, 29-34)	x	x	86	48464	Rod End, RH (silver colored)	x	x
29	48307-02	Tire Only, Caster Wheel	x	x	87	48590	Link, Turnbuckle	x	x
29A	48006-03	Inner Tube Only, Caster Wheel	x	x	88	42917	Spacer Bar	x	x
30	48307-04	Rim Pair, Caster Wheel	x	x	89	43042	Sleeve, Cam Clutch	x	x
31	48006-07	Retainer, Bearing, Caster Wheel	x	x	90	04041-08	Washer 3/4 (49/64 x 1-1/4 x 16 ga.)	x	x
32	48006-06	Roller Bearing, Caster Wheel	x	x	91	43043	Sleeve, Clutch Rod	x	x
33	48114-03	Grease Fitting, 45° 1/4-28	x	x	92	*	Cotter Pin, 3/32 x 1	x	x
34	48006-05	Hub Assy. w/Bolts	x	x	93	*	Washer, 33/64 x 1 x 16 ga.	x	x
35	*	Bolt, Hex Hd., 5/16-18 x 3/4	x	x	94	04062-01	Hair Pin, Large	x	x
36	48038	Guide Roller	x	x	95	*	Bolt, Hex Hd., 3/8-16 x 1	x	x
37	45046	Roller Shaft	x	x	96	421107	Cam Link	x	x
38	*	Washer, 3/8 x 7/8 x 13 ga.	x	x	97	*	Bolt, Hex Hd., 1/2-20 x 2	x	x
39	45029	Discharge Chute	x	x	98	44054	Rod, Blade Engage (approx. 27" long)	x	x
40	*	Hex Nut, 5/16-18 Elastic Stop	x	x	99	48083	Belt, Cutter Drive	x	
41	*	Bolt, Hex Hd., 5/16-18 x 1	x	x	99	48359	Belt, Cutter Drive		x
42	446151	Belt Cover (incl. Decals)	x		100	*	Bolt, Hex Hd., 5/16-18 x 1	x	x
42	46395	Belt Cover (incl. Decals)		x	101	45329	Idler Pivot	x	x
43	*	Washer, 25/64 x 15/16 x 12 ga.	x	x	102	48531	Pulley, Idler	x	x
44	04029-03	Wing Nut, 3/8-16	x	x	103	48681	Seal, Tapered Bearing Spindle	x	x
45	43123	Spacer	x	x	104	43218	Sleeve, Tapered Bearing Spindle	x	x
46	42045	Belt Cover Skirt	x	x	105	48677	Relief Fitting, Tapered Bearing Spindle	x	x
47	*	Mach Scrw, 1/4-20 x 1/2 Truss Hd.	x	x	106	*	Roll Pin, 1/8 x 1/2"	x	x
48	*	Lockwasher, Spring, 1/4	x	x	107	43217	Bushing, Tapered Bearing Spindle	x	x
49	*	Hex Nut, 1/4-20	x	x	108	48100-02	Bronze Bearing	x	x
50	48127	Pulley (incl. 51-52)	x	x	109	04050-05	Retaining Ring - Est. "E" - 1-1/8"	x	x
51	48141	Taper Hub	x	x	110	*	Hex Hd. Bolt, 3/8-16 x 1-1/2"	x	x

* Common hardware which should be purchased locally. All bolts Grade 5 plated, all other fasteners zinc plate.

ENGINE DECK

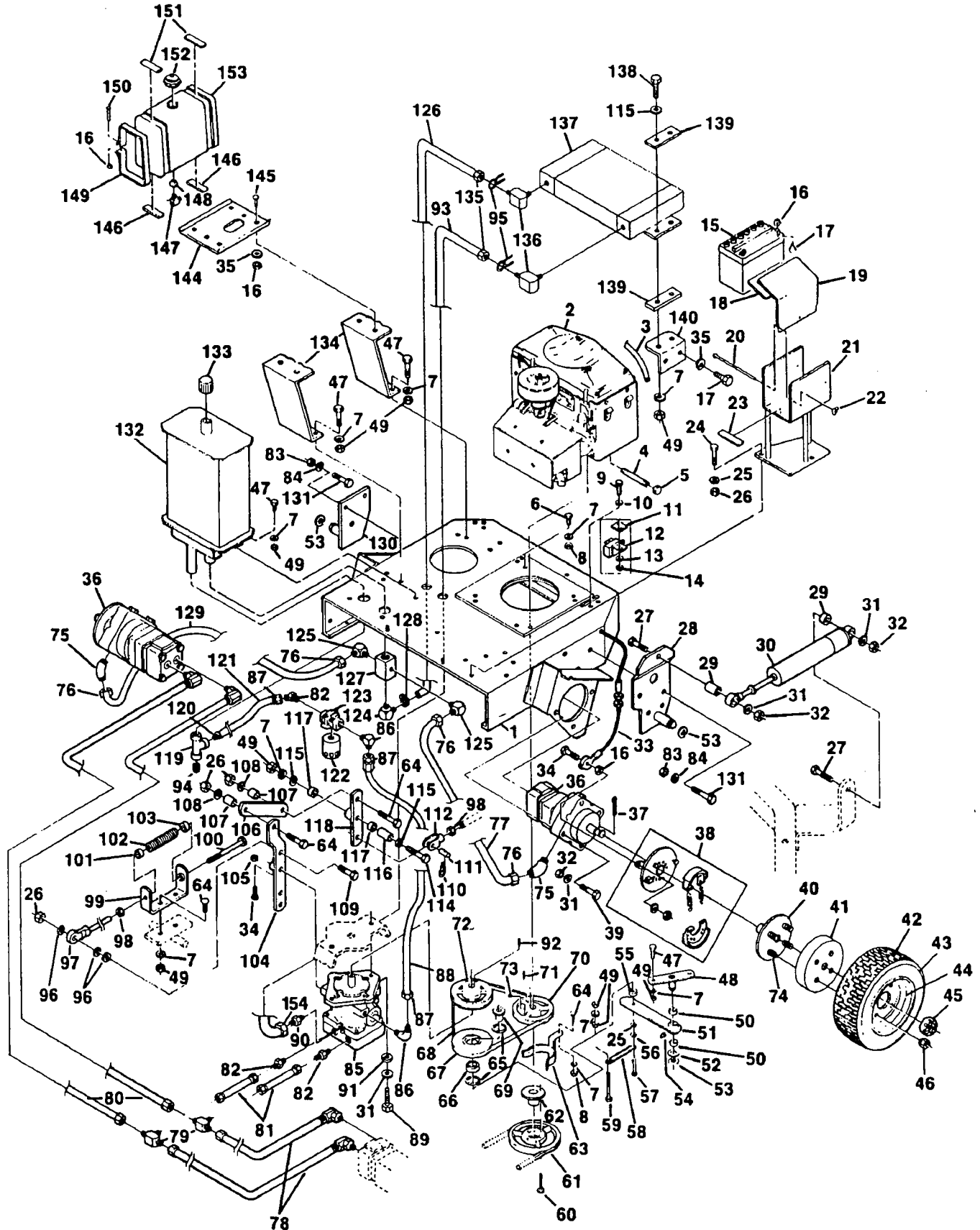

ENGINE DECK

Ref. No.	Part Number	Description
1	45368	Engine Deck
2	48371	Engine, 20 HP Kohler (MV20S PS-57511)
3	48058-13	Hose, Fuel
4	48511	Oil Drain Extension (Includes plug)
5	*	Cap, 3/8 JIC Male Plug
6	*	Bolt, Hex Hd., 5/16-18 x 1-3/4
7	*	Lockwasher, 5/16 Spring
8	04021-10	Hex Nut, Elastic Stop Lock, 5/16-18
9	*	Screw, Hex Hd., #10-32 x 3/4
10	*	Flat Washer, #10
11	42459	Stop, Mower Engage
12	48395	Switch, Mower Engage
13	*	Lockwasher, External Tooth, #10
14	*	Hex Nut, #10-32
15	48015	Battery
16	*	Hex Nut, 1/4-20
17	*	Bolt, Hex Hd., 1/4-20 x 1/2
18	48099	Insulation, Battery Cover
19	42392	Battery Cover
20	*	Bolt, Carriage Rd. Hd. Sq. Nk., 1/4-20 x 6
21	45265	Battery Box
22	04029-01	Wing Nut, 1/4-20
23	48661	Pad, Battery Support
24	*	Bolt, Hex Hd., 3/8-16 x 1
25	*	Lockwasher, 3/8 Spring
26	*	Hex Nut, 3/8-16
27	*	Bolt, Hex Hd., 1/2-13 x 2
28	45257	Hitch Bracket, LH
29	43041	Sleeve, Shock Absorber Mount
30	48516	Shock Absorber
31	*	Lockwasher, 1/2 Spring
32	*	Hex Nut, 1/2-13
33	48467	Parking Brake Cable Assembly - LH
33a	48466	Parking Brake Cable Assembly - RH
34	*	Bolt, Hex Hd., 1/4-20 x 1-1/4
35	*	Lockwasher, 1/4 Spring
36	48439	Motor, White (Includes item 45, less brake assy.)
37	*	Cotter Pin, 5/32 x 1-1/2
38	48461	Parking Brake Assembly
39	*	Bolt, Hex Hd., 1/2-13 x 2-1/2
40	45332	Hub Assembly (Includes Bolts)
41	48513	Brake Drum
42	48416-07	Rim and Tire Assembly
43	48416-02	Tire, 20 x 8.00-10, 4 ply
44	48416-04	Rim Only
45	04027-03	Castle Nut, 1.0-20 UNEF
46	04028-01	Wheel Nut
47	*	Bolt, Hex Hd., 5/16-18 x 3/4
48	45037	Idler Pivot Base
49	*	Hex Nut, 5/16-18
50	48100-05	Bronze Bushing
51	46327	Pump Idler Arm (Includes (2) 50 and (1) 54)
52	04041-08S	Flat Washer, 3/4 (49/64 x 1-1/4 x .035)
53	04050-02	Retaining Ring, 3/4 "E"
54	48114-01	Grease Fitting
55	43063	Spacer, Idler
56	*	Hex Nut, Jam 3/8-16

* Common hardware which should be purchased locally. All bolts grade 5 plated, all other fasteners zinc plate.

ENGINE DECK CONTINUED ON FOLLOWING PAGE

ENGINE DECK CONT'D

Ref. No.	Part Number	Description
57	*	Bolt, Hex Hd., 3/8-16 x 1-1/2
58	48560	Spring, Traction Drive Belt
59	*	Bolt, Hex Hd., 5/16-18 x 2-1/4
60	*	Bolt, Hex Hd., 1/4-20 x 1-3/8
61	48378-01	Pulley, Blade Drive (includes 60 and 62)
62	48378-03	Hub, Tapered
63	45222	Belt Guide
64	*	Bolt, Carriage Rd. Hd. Sq. Nk., 5/16-18 x 1
65	04050-06	Retaining Ring, 1-9/16 Internal
66	48102	Bearing, Idler Pulley
67	46370	Pulley, Idler - Traction Drive (incl. 65, 66, 69)
68	48585	Belt, Pump Drive
69	43117	Sleeve, Idler (tapped)
70	48583	Pulley, Engine - Pump
71	04063-11	Key, 1/4 x 1/4 x 2-1/2 (plated)
72	48581	Pulley, Pump Input
73	*	5/16-18x3/8" Hex Socket Set Screw
74	04008-01	Bolt, Hub
75	48485-03	Elbow, 45 deg. Male, JIC to "O" ring
76	48353-02	Coupling, SAE Flare Swivel, Push On Hose End
77	48482-02	Hose, Push On 1/4 ID - LH
78	48501	Hose Assembly - LH Motor
79	48505-01	Tube Tee
80	48509	Hose Assembly - RH Motor
81	48500	Tube Assembly
82	48485-01	Elbow, 45 deg. Male, JIC to "O" ring
83	*	Hex Nut, 7/16-14
84	*	Lockwasher, 7/16 Spring
85	48438	Pump, Sunstrand
86	48350-02	Elbow, 90 deg., JIC to "O" ring
87	48353-01	Coupling, SAE Flare Swivel, Push On Hose End
88	48351-07	Hose, 1/2 ID, Oil Filter to Pump
89	04015-03	Capscrew, 1/2-13 x 1-1/4 Socket Hd.
90	48483-02	Union, Tube JIC to "O" ring
91	*	Flat Washer, 1/2
92	04063-12	Key, 3/16 x 5/8 Woodruff #61
93	48634	Hose
94	48731-02	Pipe Plug, 1/2 NPT - Magnetic
95	48502-02	Corbin Clamp -1"
96	*	Flat Washer, 3/8 (.406 x .821 x .065)
97	48464	Rod End
98	*	Hex Nut, 3/8-24
99	42667	Retainer, Neutral Spring
100	48512	Bolt, Hex Hd., 3/8-24 x 6-3/4 special
101	43151	Bushing, Spring Keeper, Short
102	48463	Spring, Neutral Return
103	43150	Bushing, Spring Keeper, Long
104	45260	Control Arm, Pump
105	04021-08	Hex Nut, Elastic Stop Lock, 1/4-20
106	42658	Link, Speed Control
107	43042	Sleeve, Pump Control Link
108	*	Flat Washer, 3/8 (25/64 x 15/16 x 12 ga.)
109	*	Bolt, Carriage Rd. Hd. Sq. Nk., 3/8-16 x 1-1/2
110	04062-02	Hair Pin Cotter, Small
111	44024	Clevis Pin
112	48343-02	Clevis, Pump Control
114	*	Bolt, Hex Hd., 5/16-18 x 2-3/4
115	*	Flat Washer, 5/16 (.344 x .688 x .065)
116	43110	Sleeve, Control Arm

* Common hardware which should be purchased locally. All bolts grade 5 plated, all other fasteners zinc plate.

ENGINE DECK CONTINUED ON FOLLOWING PAGE

ENGINE DECK CONT'D

Ref. No.	Part Number	Description
117	48100-04	Bronze Bushing
118	46328	Control Arm, Bellcrank (Includes (2) 117)
119	48365	Pipe Tee, 1/2 NPT
120	48352-01	Coupling, Straight Male, Pipe NPT, Push On Hose End
121	48351-06	Hose, Tee to Oil Filter
122	48462-01	Oil Filter (special)
123	48462-02	Head, Oil Filter
124	48486-02	Elbow, 90 deg. Male, Pipe NPT, Push On Hose End
125	48489-01	Elbow, 90 deg. Male, JIC to NPT
126	48635	Hose
127	48532	Manifold
128	48136-04	Clamp, Worm Drive
129	48482-01	Hose, Push On, 1/4 ID - RH
130	45256	Hitch Bracket - RH
131	*	Bolt, Hex Hd, 7/16-14 x 1
132	45256	Oil Reservoir
133	48376	Cap, Oil Reservoir
134	42386	Mounting Bracket, Fuel Tank
135	48353-04	Coupling
136	48350-05	Elbow 90 deg
137	48645	Radiator, Oil Cooler
138	*	Bolt, Hex Hd 5/16-18x1 1/4.
139	48636	Pad, Rubber
140	42925	Bracket, Radiator Mounting
141	+	Part Removed From Illustration
142	+	Part Removed From Illustration
143	+	Part Removed From Illustration
144	42377	Support, Fuel Tank
145	*	Bolt, Carriage Rd. Hd. Sq. Nk., 1/4-20 x 3/4
146	48205	Pad, Fuel Tank Support
147	48308	Fuel Shut Off Valve
148	48309	Bushing, Fuel Tank Valve
149	42369	Strap, Fuel Tank
150	*	Screw, Slotted Rd. Hd. Machine, 1/4-20 x 2
151	48292	Pad, Fuel Tank Strap
152	48658	Cap, Fuel Tank
153	46174	Fuel Tank Assembly (Includes 147, 148)
154	48353-03	Coupling, 3/4-16 SAE Flare Swivel, 5/8" Push-On

* Common hardware which should be purchased locally. All bolts grade 5 plated, all other fasteners zinc plate.

INSTRUMENT PANEL

AA - Fuse Holders
Part of Wiring Harness
See Page 20.

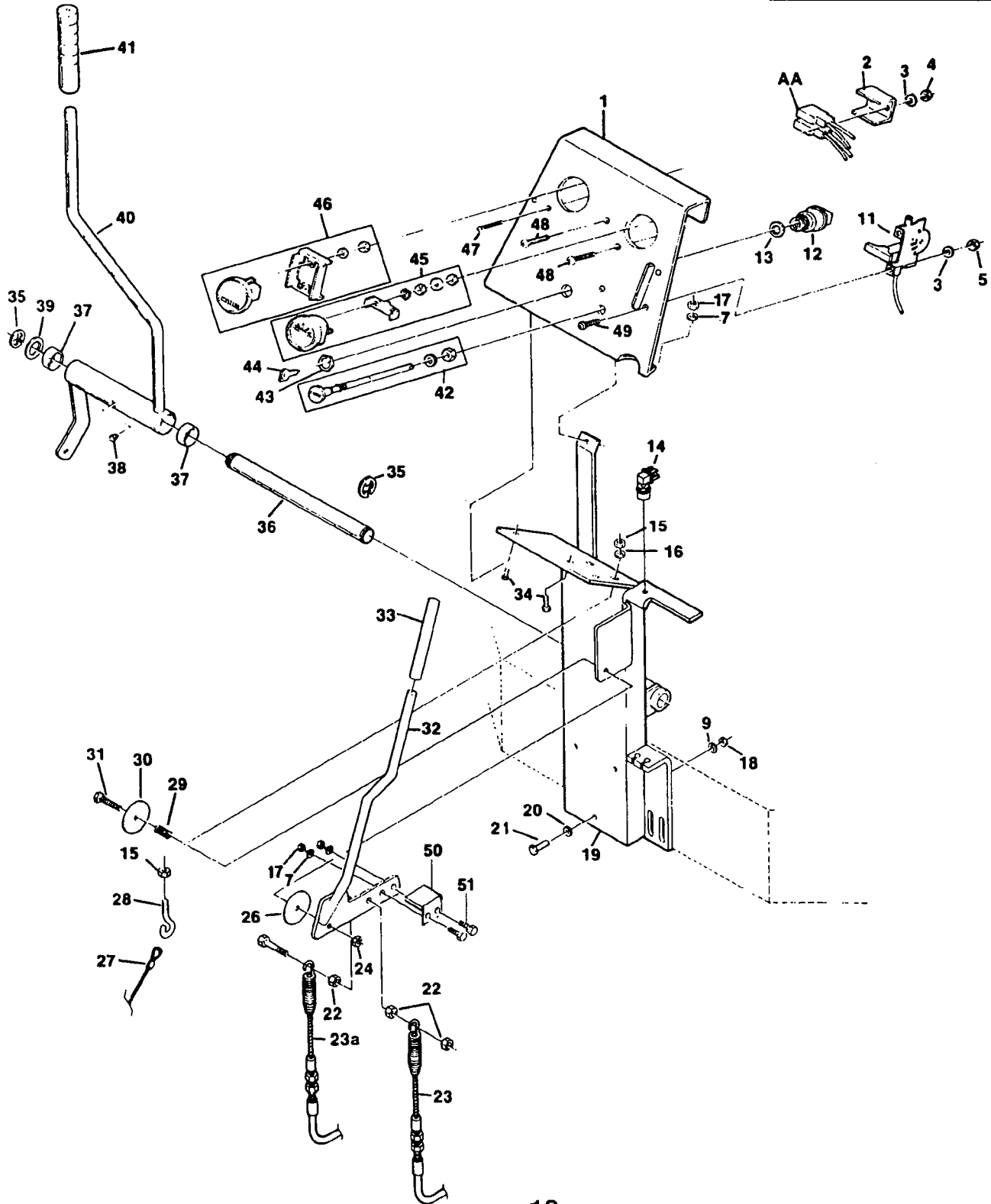

INSTRUMENT PANEL

Ref. No.	Part Number	Description
1	46330	Instrument Panel (includes decal)
2	42413	Bracket, Fuse Holder
3	04031-01	Lockwasher, #10 external tooth
4	04021-01	Hex Nut, Elastic Stop Lock #10-32
5	*	Hex Nut, #10-32
6	*	Flat Washer, 1/4"
7	*	Lockwasher, 1/4 spring
8	*	Hex Nut, 5/16-18
9	*	Lockwasher, 5/16 spring
10	+	Removed From Illustration
11	48090	Throttle Control
12	48017	Switch, Key
13	48017-03	Lockwasher, 5/8 internal tooth
14	48522	Switch, Parking Brake
15	*	Hex Nut, 3/8-16
16	*	Lockwasher, 3/8 spring
17	*	Hex Nut, 1/4-20
18	*	Hex Locknut, 5/16
19	45284	Console Support
20	*	Flat Washer, 5/16
21	*	Bolt, Hex Hd., 5/16-18 x 2-1/4
22	*	Hex Lock Jam Nut, 3/8-16
23	48466	Cable Assy., Parking Brake - RH
23A	48467	Cable Assy., Parking Brake - LH
24	04021-09	Hex Nut, Elastic Stop Lock 3/8-16
25	*	Bolt, Hex Hd., 3/8-16 x 1-3/4
26	04041-12	Flat Washer, 3/8 x 1-1/2 x 16 ga.
27	48045	Cable, Winch
28	04070-03	Eye Bolt, 3/8-16 x 2
29	48050	Spring, Shift Lever
30	04041-12	Flat Washer, 3/8 x 1-1/2 x 16 ga.
31	*	Bolt, Hex Hd., 3/8-16 x 1-3/4
32	45285	Handle, Parking Brake
33	48342	Grip, Parking Brake
34	*	Bolt, Hex Hd., 1/4-20 x 3/4
35	04050-02	Retaining Ring, 3/4 "E"
36	43158	Shaft, Bellcrank Pivot
37	48100-06	Bronze Bushing
38	48114-01	Grease Fitting
39	*	Flat Washer, 3/4 (49/64 x 1-1/4 x 16 ga.)
40	45022	Bellcrank, Belt Clutch
41	48093	Grip, Clutch Lever
42	48091	Choke Control (includes hardware)
43	48017-04	Hex Nut, 5/8-11
44	48017-02	Key, Ignition
45	48022	Ammeter (includes hardware)
46	48023	Hour Meter (includes hardware)
47	*	Screw, Phillips Hd., #10-32 x 1-1/2
48	*	Screw, Phillips Truss Hd., 1/4-20 x 3/4
49	*	Screw, Phillips Washer Hd., #10-32 x 1/2
50	42729	Bkt, Parking Brake Switch Actuating
51	*	Hex Head Bolt, 1/4-20x3/4

* Common hardware which should be purchased locally. All bolts grade 5 plated, all other fasteners zinc plate.

RIDER FRAME ASSEMBLY

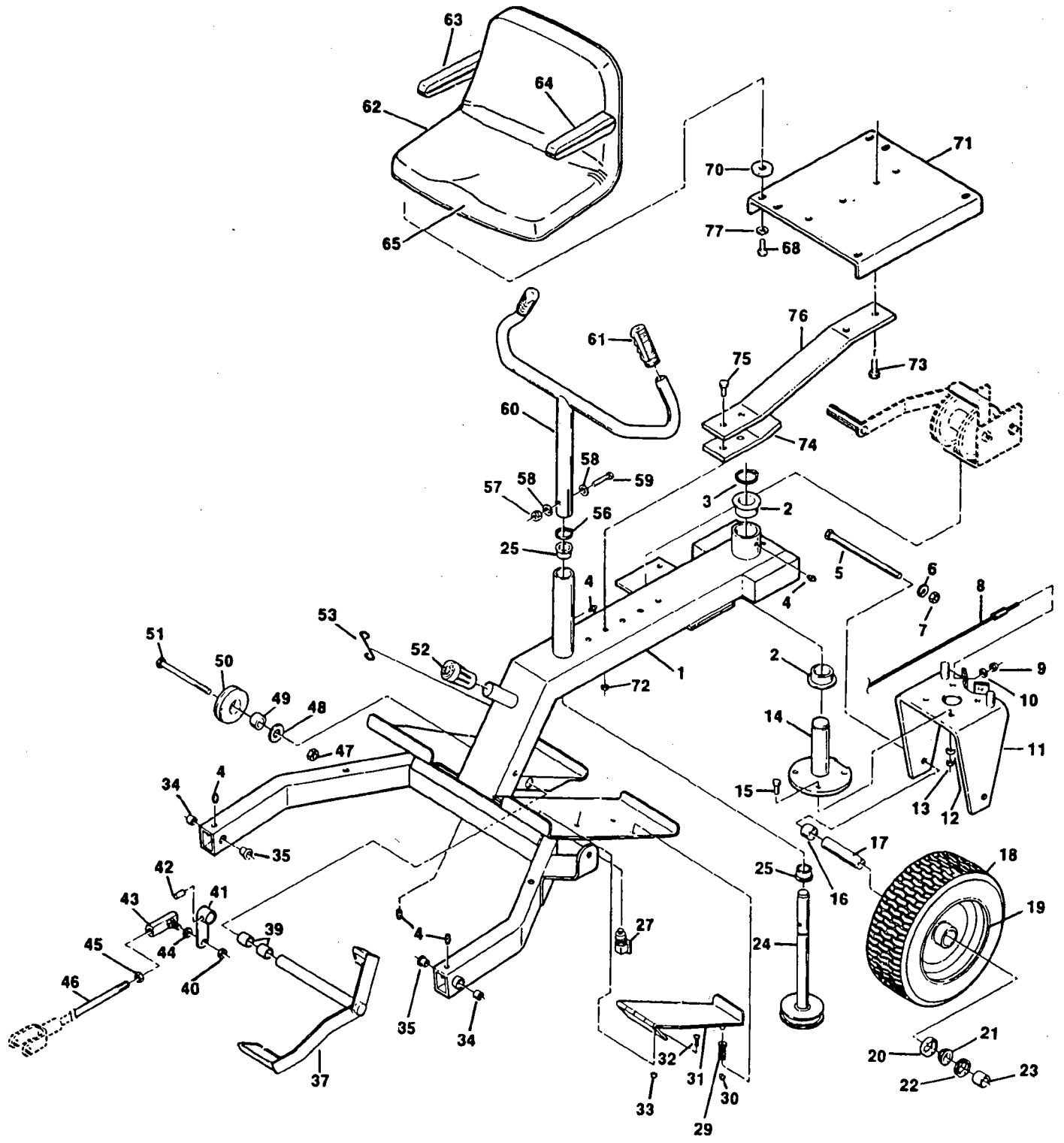

RIDER FRAME ASSEMBLY

Ref. No.	Part Number	Description
1	46380	Steering Frame (incl. bushings & grease fittings)
2	48100-02	Bronze Bushing
3	04050-05	Retaining Ring, 1-1/8 external
4	48114-01	Grease Fitting
5	*	Bolt, Hex Hd. 5/8-11 x 9
6	*	Lock Washer, 5/8 spring
7	*	Hex Nut, 5/8-11
8	48042	Cable, Steering
9	*	Hex Nut, 1/4-28 lock
10	*	Flat Washer, 1/4
11	45035	Rear Wheel Yoke
12	*	Lock Washer, 3/8 spring
13	*	Hex Nut, 3/8-16
14	45008	Rear Wheel Pivot
15	*	Bolt, Hex Hd., 3/8-16 x 1-3/8
16	43020-02	Spacer, Rear Wheel
17	43021	Sleeve, Rear Wheel
18	48005-01	Rear Wheel Assy. (Incl. 19,20,21,22)
19	48005-03	Rim Only
20	48005-04	Bearing Cup
21	48005-05	Bearing Cone
22	48005-06	Seal, Grease
23	43020-01	Spacer, Rear Wheel, short
24	45009	Steering Shaft
25	48100-07	Bronze Bushing
26	+	Part Removed From Illustration
27	48026	Switch, Foot Safety
28	+	Part Removed From Illustration
29	48049	Spring, Foot Safety Switch
30	04021-08	Hex, Nut, Elastic Stop Lock, 1/4-20
31	45175	Pedal, Foot Safety Switch
32	*	Screw, slotted flat hd #10-32 x 3/4
34	48100-06	Bronze Bushing
35	48100-03	Bronze Bushing
36	+	Part Removed From Illustration
37	45151	Foot Pedal
38	+	Part Removed From Illustration
40	*	Hex Locknut, 3/8-24
41	45264	Foot Pedal Arm
42	04065-01	Pin, Drive Lock, 3/16 x 1-1/4
43	48118	Ball Joint
44	*	Flat Washer, 3/8
45	*	Hex Nut, 3/8-24
46	44044	Control Rod
47	04021-07	Hex Nut, Elastic Stop Nut, 1/2-13
48	*	Flat Washer, 1/2 (.531 x 1.062 x .095)
49	48100-04	Bronze Bushing
50	48208	Pulley, Winch Cable
51	*	Bolt, Hex Hd., 1/2-13 x 5-1/2
52	48097	Bumper Stop Cover
53	44028	Retainer, Winch Cable
54	+	Part Removed From Illustration
56	04050-03	Retaining Ring, 7/8 external
57	*	Hex Nut, 5/16-18 center lock
58	*	Flat Washer, 3/8 x 7/8 x 13 ga.
59	*	Bolt, Hex Hd., 5/16-18 x 1-1/2
60	46029	Steering Handle (Incl. 61)
61	48159	Grip

* Common hardware which should be purchased locally. All bolts grade 5 plated, all other fasteners zinc plate.

RIDER FRAME ASSEMBLY CONTINUED ON NEXT PAGE

RIDER FRAME ASSEMBLY CONT'D

Ref. No.	Part Number	Description
62	48702	Seat Assy. (incl. 63,64 &65)
63	48704-04	Arm Pad - R.H.
64	48704-05	Arm Pad L.H.
65	48704-03	Cushion Assembly
70	04041-11	Flat Washer, 13/32 x 1-1/2 x 7 ga.
71	45210	Seat Plate
72	*	Hex Elastic Stop Nut, 7/16-14
73	*	Bolt, Hex Hd., 3/8-16 x 1
74	42366	Reinforcement, Seat Spring
75	*	Bolt, Hex Hd., 7/16-14 x 3-1/2
76	42026	Seat Spring
77	*	Lock Washer, 5/16 spring

* Common hardware which should be purchased locally. All bolts grade 5 plated, all other fasteners zinc plate.

WINCH LIFT SYSTEM

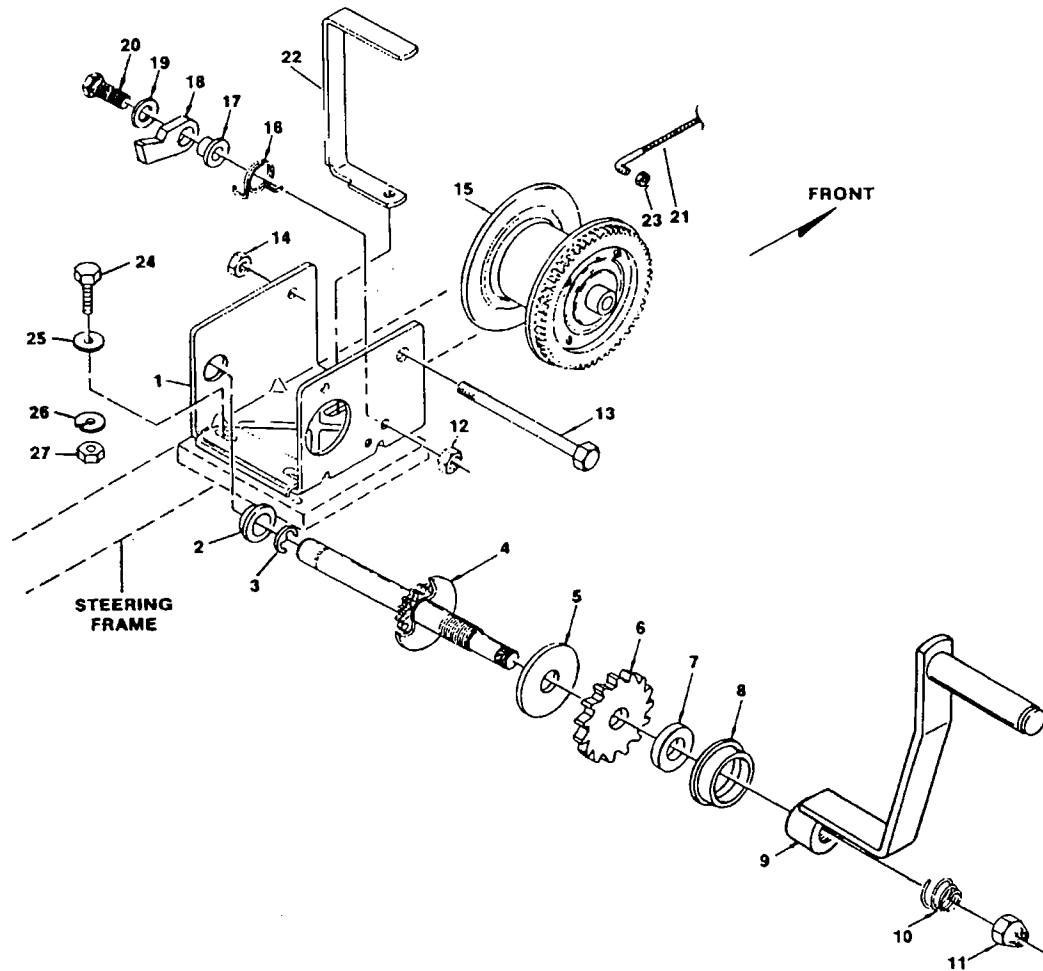

Ref. Part No.	Part Number	Description	Ref. Part No.	Part Number	Description
1	48043	Winch Assembly (incl. 1-8, 10-20)	15	304227	Winch Reel
2	204009	Shaft Bushing	16	204363	Ratchet Spring
3	205116	E-Ring	17	404166	Ratchet Spacer
4	304228	Drive Shaft	18	404409	Ratchet Pawl
5	204362	Pressure Plate	19	205024	Flat Washer
6	404164	Ratchet Wheel	20	205167	Ratchet Bolt
7	404163	Pressure Washer	21	48045	Winch Cable Assembly
8	204359	Shaft Bushing	22	42127	Cable Guide
9	48044	Winch Handle	23	04021-03	Hex Lock Nut, 1/4-28
10	204364	Handle Spring	24	*	Hex Hd. Bolt, 3/8-16 x 1
11	205015	Handle Nut	25	*	Flat Washer, 13/32 x 13/16 x 16 ga.
12	205011	Hex Locknut, 3/8-16	26	*	Lock Washer, 3/8 spring
13	205008	Reel Shaft	27	*	Hex Nut, 3/8-16
14	205155	Lock Nut, 7/16-14			

* Common hardware which should be purchased locally. All bolts grade 5 plated, all other fasteners zinc plate.

ELECTRICAL SYSTEM INSTRUMENT PANEL

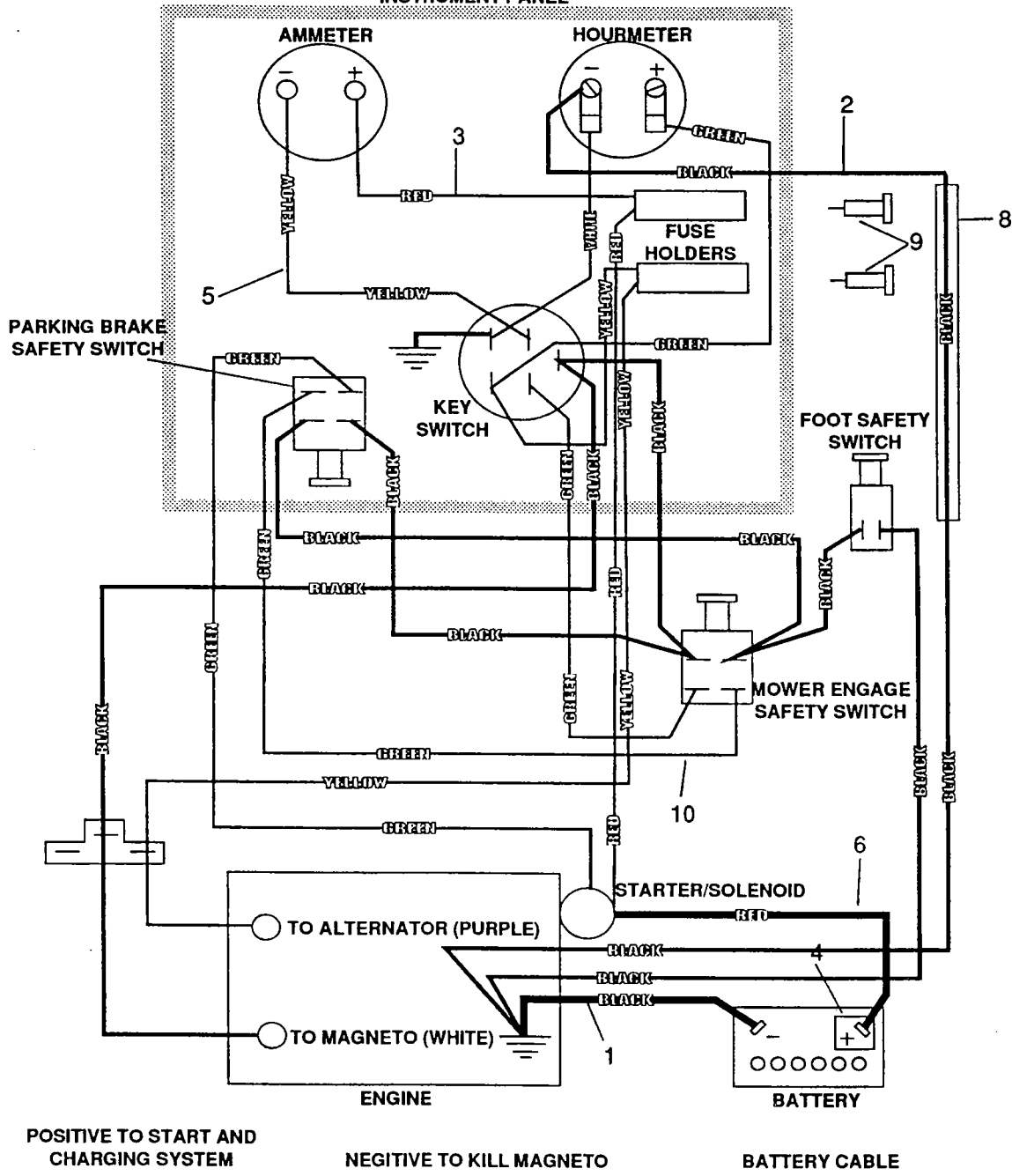

Ref. Part No.	Part No.	Description	Ref. Part No.	Part No.	Description
1	48029-01	Battery Cable, Ground	8	48033-01	Conduit, Black Nylon
2	48616	Wire Harness, Foot Safety Switch	9	48298	Fuse, 20 AMP Blade Type Automotive
3	48368	Wire Harness, Solenoid to Ammeter	10	48615	Wire Harness, Lower
4	48126	Rubber Boot	NS	48028-01	Cable Tie
5	48743	Wire Harness, Instrument panel	NS	48498	Wire Harness Adapter
6	48029-02	Battery Cable, Long			

REPLACEMENT DECALS



1



2



3



4 - 6



7

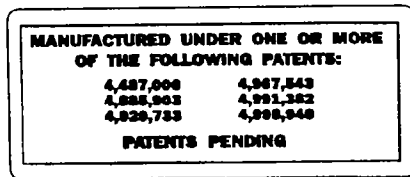

8

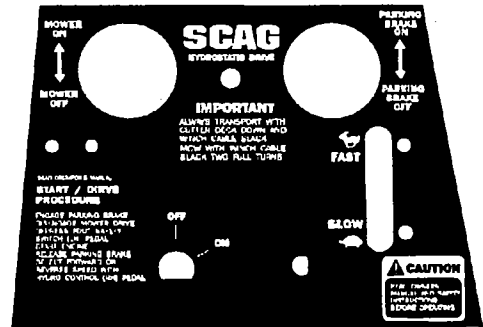

9

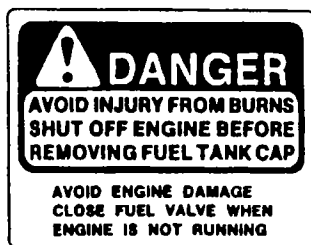

10



11

Ref. No.	Part Number	Description	Ref. No.	Part Number	Description
1	48072	Decal, Heavy Duty Commercial	7	48073	Decal, Danger
2	48314	Decal, Scag Logo	8	48656	Decal, Patent
3	48071	Decal, OPEI Safety	9	48460	Decal, Instrument Panel
4	48319	Decal, 52	10	48281	Decal, Operator Warning - Fuel Fill
5	48320	Decal, 61	11	48401	Decal, Cutting Height Adjustment
6	48327	Decal, 72			

WARNING

If incorrectly used, this machine can cause severe injury. Those who use and maintain the machine should be trained in its proper use, warned of its dangers, and should read the entire manual before attempting to set up, operate, adjust or service the machine.

LIMITED WARRANTY-COMMERCIAL EQUIPMENT

Any part of the Scag commercial mower manufactured by Scag and found, in the reasonable judgment of Scag, to be defective in material or workmanship, will be repaired or replaced by an Authorized Scag Service Dealer without charge for parts and labor.

The Scag mower including any defective part must be returned to an Authorized Scag Service Dealer within the warranty period. The expense of delivering the mower to the dealer for warranty work and the expense of returning it back to the owner after repair or replacement will be paid for by the owner. Scag's responsibility in respect to claims is limited to making the required repairs or replacements, and no claim of breach of warranty shall be cause for cancellation or rescission of the contract of sale of any Scag mower. Proof of purchase will be required by the dealer to substantiate any warranty claim. All warranty work must be performed by an Authorized Scag Service Dealer.

This warranty is limited to one year from the date of original retail purchase for any Scag mower that is used for commercial purposes, or any other income-producing purpose (90 days for rental use). Traction drive system will be warranted for two full years from date of original retail purchase against defects in material or workmanship excluding hoses, lines and drive belts. Belts and tires are warranted for 90 days against defects in workmanship or materials.

This warranty does not cover any mower that has been subject to misuse, neglect, negligence, or accident, or that has been operated in any way contrary to the operating instructions as specified in the Technical Manual. The warranty does not apply to any damage to the mower that is the result of improper maintenance, or to any mower or parts that have not been assembled or installed as specified in the Technical Manual.

The warranty does not cover any mower that has been altered or modified. In addition, the warranty does not extend to repairs made necessary by normal wear, or by the use of parts or accessories which, in the reasonable judgment of Scag, are either incompatible with the Scag mower or adversely affect its operation, performance or durability. This warranty does not cover engines and electric starters, which are warranted separately by their manufacturer.

Scag Power Equipment reserves the right to change or improve the design of any mower without assuming any obligation to modify any mower previously manufactured.

All other implied warranties are limited in duration to the one (1) year warranty period or ninety (90) days for mowers used for rental purpose. Accordingly, any such implied warranties including merchantability, fitness for a particular purpose, or otherwise, are disclaimed in their entirety after the expiration of the appropriate one-year or ninety day warranty period. Scag's obligation under this warranty is strictly and exclusively limited to the repair or replacement of defective parts and Scag does not assume or authorize anyone to assume for them any other obligation. Some states do not allow limitations on how long an implied warranty lasts, so the above limitation may not apply to you.

Scag assumes no responsibility for incidental, consequential or other damages including, but not limited to, expense for gasoline, expense of delivering the mower to an Authorized Scag Service Dealer and expense of returning it back to the owner, mechanic's travel time, telephone or telegram charges, rental of a like product during the time warranty repairs are being performed, travel, loss or damage to personal property, loss of revenue, loss of use of the mower, loss of time or inconvenience. Some states do not allow the exclusion or limitation of incidental or consequential damages. So the above limitation or exclusion may not apply to you.

This warranty gives you specific legal rights, and you may also have other rights which vary from state to state.

PLEASE BE CAREFUL

1. Keep all shields in place, especially grass discharge guard.
2. Stop machine and remove spark plug wire to adjust or service.
3. When mechanism becomes clogged, stop engine before cleaning.
4. Keep hands, feet and clothing away from power-driven parts.
5. Keep off implement unless seat or platform is provided.
6. Keep others off of the tractor (only one person at a time).

REMEMBER - YOUR MOWER IS ONLY AS SAFE AS THE OPERATOR!

FAILURE TO FOLLOW CAUTIOUS OPERATING PRACTICES MAY RESULT IN SERIOUS BODILY INJURY. BESIDES, WE WOULD LIKE YOU TO CONTINUE TO ENJOY AND PROFIT BY USING OUR PRODUCTS.

OWNER REFERENCE

TRACTOR MODEL _____

TRACTOR SERIAL NUMBER _____

MOWER MODEL _____

MOWER SERIAL NUMBER _____