

Poulan

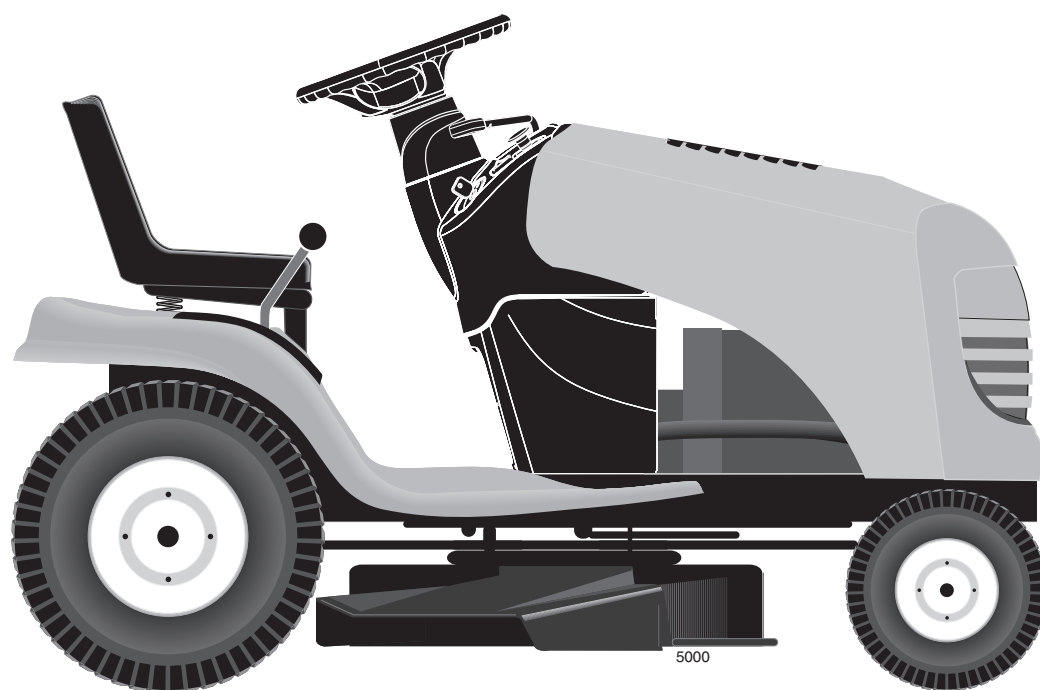

REPAIR PARTS MANUAL

MODEL:

PO12530LT

LAWN TRACTOR

ALWAYS WEAR EYE PROTECTION DURING OPERATION

Visit our website: www.poulan-pro.com



WARNING:

Read this Manual and follow all Warnings and Safety Instructions. Failure to do so can result in serious injury.

433711

TRACTOR - MODEL NO. PO12530LT (96042010500), PRODUCT NO. 960 42 01-05 SCHEMATIC

SCH18

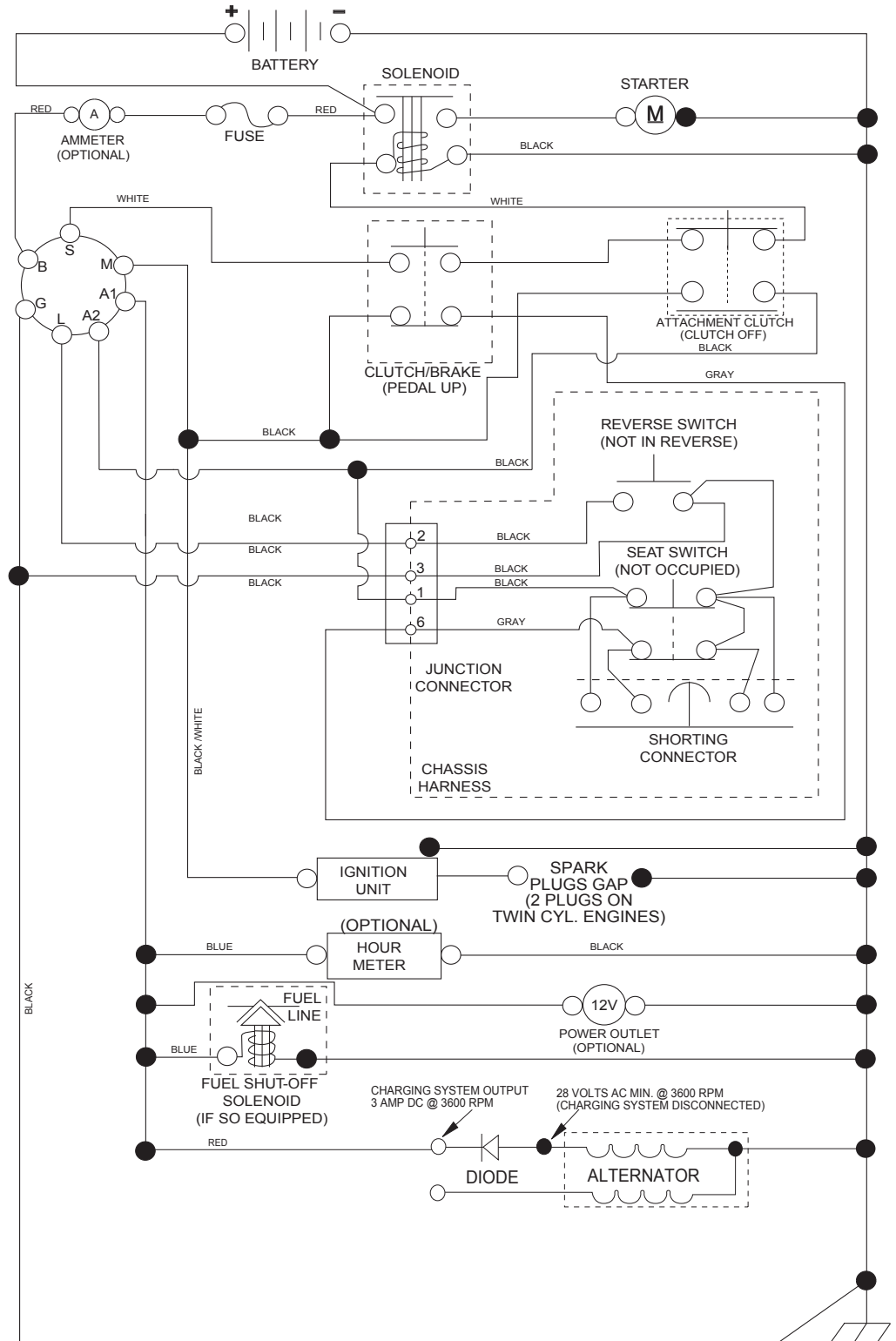

NOTE
YOUR TRACTOR IS EQUIPPED WITH A SPECIAL ALTERNATOR SYSTEM. THE LIGHTS ARE NOT CONNECTED TO THE BATTERY, BUT HAVE THEIR OWN ELECTRICAL SOURCE. BECAUSE OF THIS, THE BRIGHTNESS OF THE LIGHTS WILL CHANGE WITH ENGINE SPEED. AT IDLE THE LIGHTS WILL DIM. AS THE ENGINE IS SPEEDED UP, THE LIGHTS WILL BECOME THEIR BRIGHTEST.

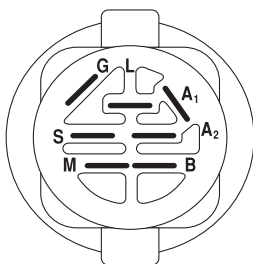

IGNITION SWITCH

POSITION	CIRCUIT	"MAKE"
OFF	M+G+A1	
RUN/OVERRIDE	B+A1	
RUN	B+A1	L+A2
START	B + S + A1	

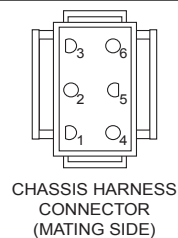

CHASSIS HARNESS CONNECTOR (MATING SIDE)

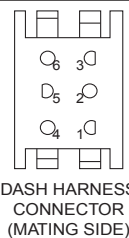

DASH HARNESS CONNECTOR (MATING SIDE)

WIRING INSULATED CLIPS
NOTE: IF WIRING INSULATED CLIPS WERE REMOVED FOR SERVICING OF UNIT, THEY SHOULD BE RE-INSTALLED TO PROPERLY SECURE YOUR WIRING.

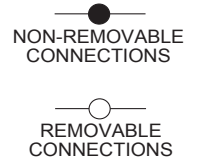

**TRACTOR - MODEL NO. PO12530LT (96042010500), PRODUCT NO. 960 42 01-05
ELECTRICAL**

T31K

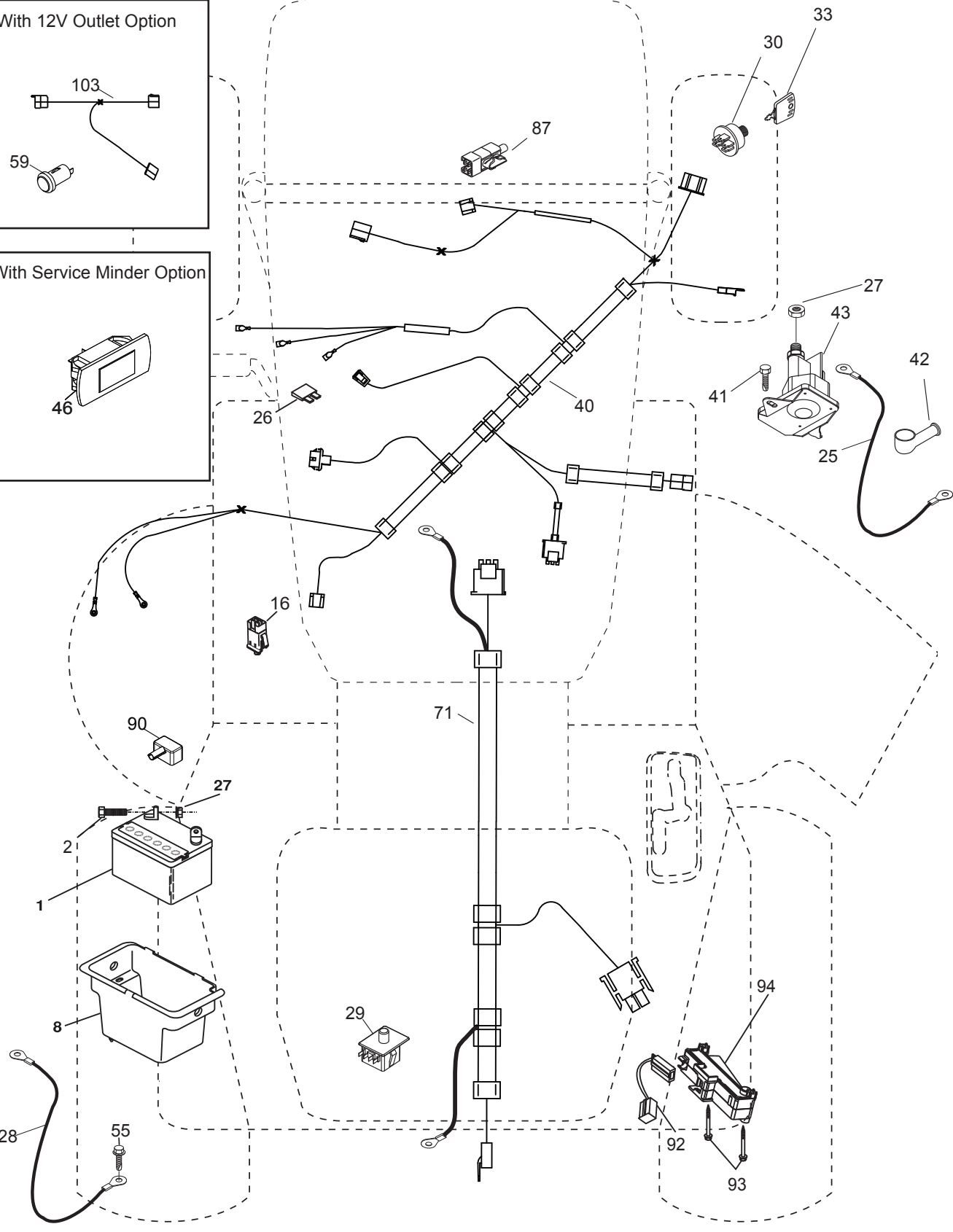
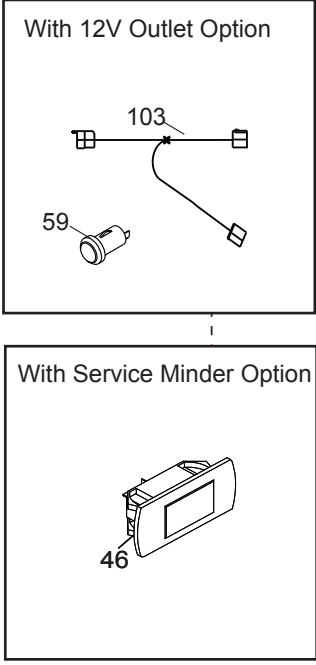

**TRACTOR - MODEL NO. PO12530LT (96042010500), PRODUCT NO. 960 42 01-05
ELECTRICAL**

KEY NO.	PART NO.	DESCRIPTION
1	144924	Battery
2	74760412	Bolt Hex Hd 1/4-20 unc x 3/4
8	193228	Box Battery
16	176138	Switch Interlock
25	412894	Cable Starter Battery 6 Ga. BL/Red 14.5
26	175158	Fuse
27	73510400	Nut Keps Hex 1/4-20 unc
28	198885	Cable Ground 18" Rear Battery Blk 6 Ga.
29	192749	Switch Seat
30	193350	Switch Ign
33	411933	Key/Chain
40	401098	Harness Ign
41	17720408	Screw 1/4-20 unc x 1/2
42	131563	Cover Terminal Red
43	192507	Solenoid
55	17060512	Screw 5/16-18 x 3/4
71	400449	Harness Ign. Chass.
87	197802	Switch Interlock Clutch
90	400725	Cover Terminal
92	196615	Harness Pigtail Reverse Switch
93	192540	Screw Plastic 10-14 x 2.0
94	191834	Modual Reverse ROS

NOTE: All component dimensions given in U.S. inches
1 inch = 25.4 mm

TRACTOR - MODEL NO. PO12530LT (96042010500), PRODUCT NO. 960 42 01-05
CHASSIS

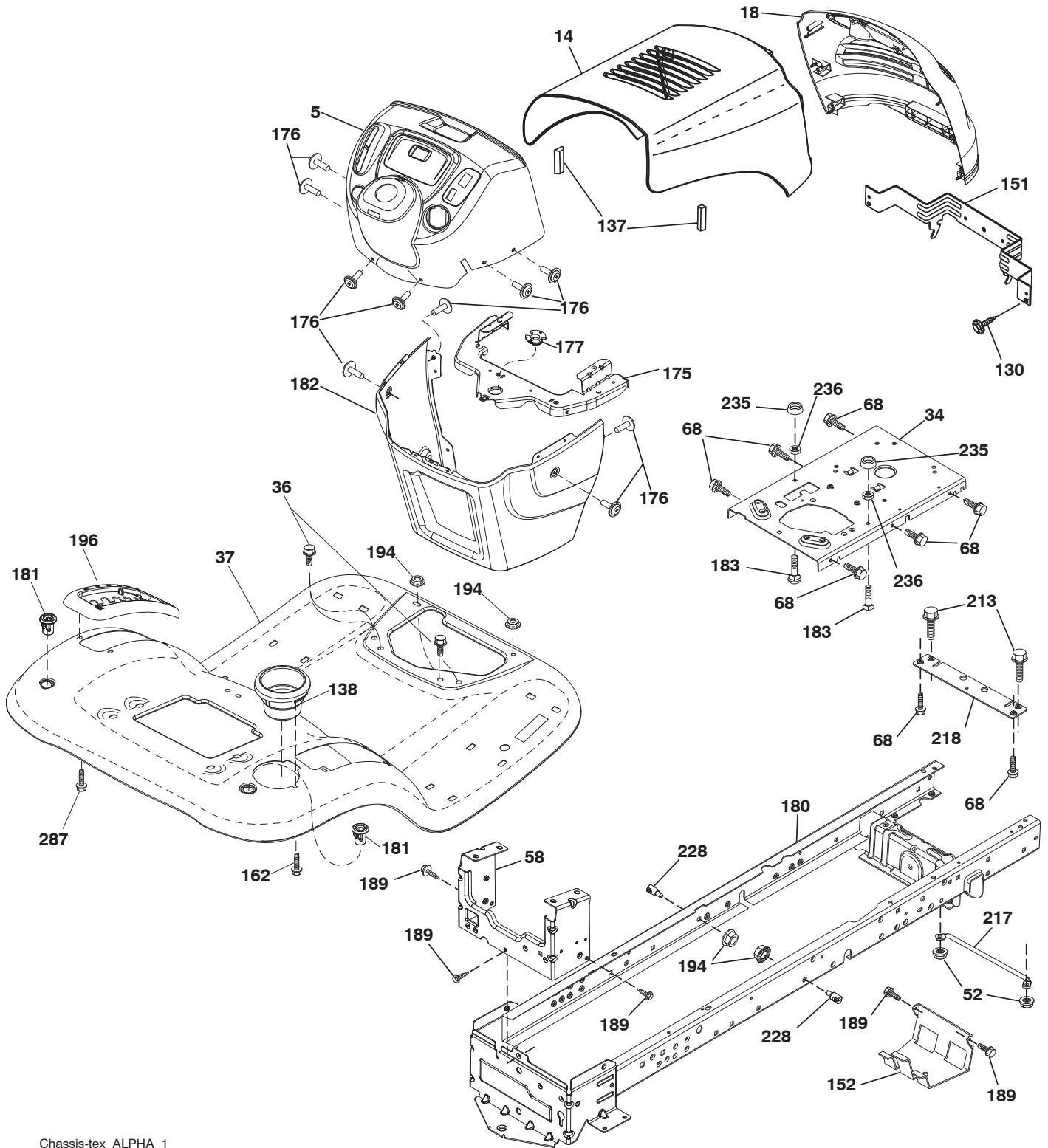

Chassis-tex_ALPHA_1

**TRACTOR - MODEL NO. PO12530LT (96042010500), PRODUCT NO. 960 42 01-05
CHASSIS**

KEY NO.	PART NO.	DESCRIPTION
5	197783X428	Dash
14	187559X428	Hood
18	433994X428	Grille
34	196125	Plate Engine
36	17060512	Screw 5/16-18 x 3/4
37	414872X505	Fender
52	73680500	Nut Lock 5/16-18
58	412280	Drawbar Upper
68	17490508	Screw Thdrol 5/16-18 x 1/2
130	416358	Screw #10 x 0.750
137	184921	Bumper Hood
138	193224X428	Cupholder
151	187568	Bracket Pivot
152	199535	Shield Browning/Debris
162	142432	Screw Hex Wsh Hi-Lo 1/4 x 1/2
175	193243	Crossmember
176	400776	Screw 10-24 x 5/8 Wshd Qdrx
177	195228	Bushing Steering
180	414685	Chassis
181	193102X428	Bushing Mtg. Fender Crgo.
182	193057	Dash Lower
183	74520520	Bolt 5/16-18 x 1-1/4
189	17000512	Screw 5/16-18 x 3/4
194	73900500	Nut Lock Hex Flange 5/16-18
196	414579	Console Asm. Deck Lift
213	74760512	Bolt 5/16-18 x 3/4
217	409167	Rod Pivot Hood
218	196395	X-Piece Hood Stop
228	195161	Stud Fastener
235	406129	Spacer Fender
236	73930500	Nut Center Lock 5/16-18
287	17600406	Screw 1/4-20 x 3/8
- - -	193640X428	Plug Switch Light

NOTE: All component dimensions given in U.S. inches
1 inch = 25.4 mm

TRACTOR - MODEL NO. PO12530LT (96042010500), PRODUCT NO. 960 42 01-05
DRIVE

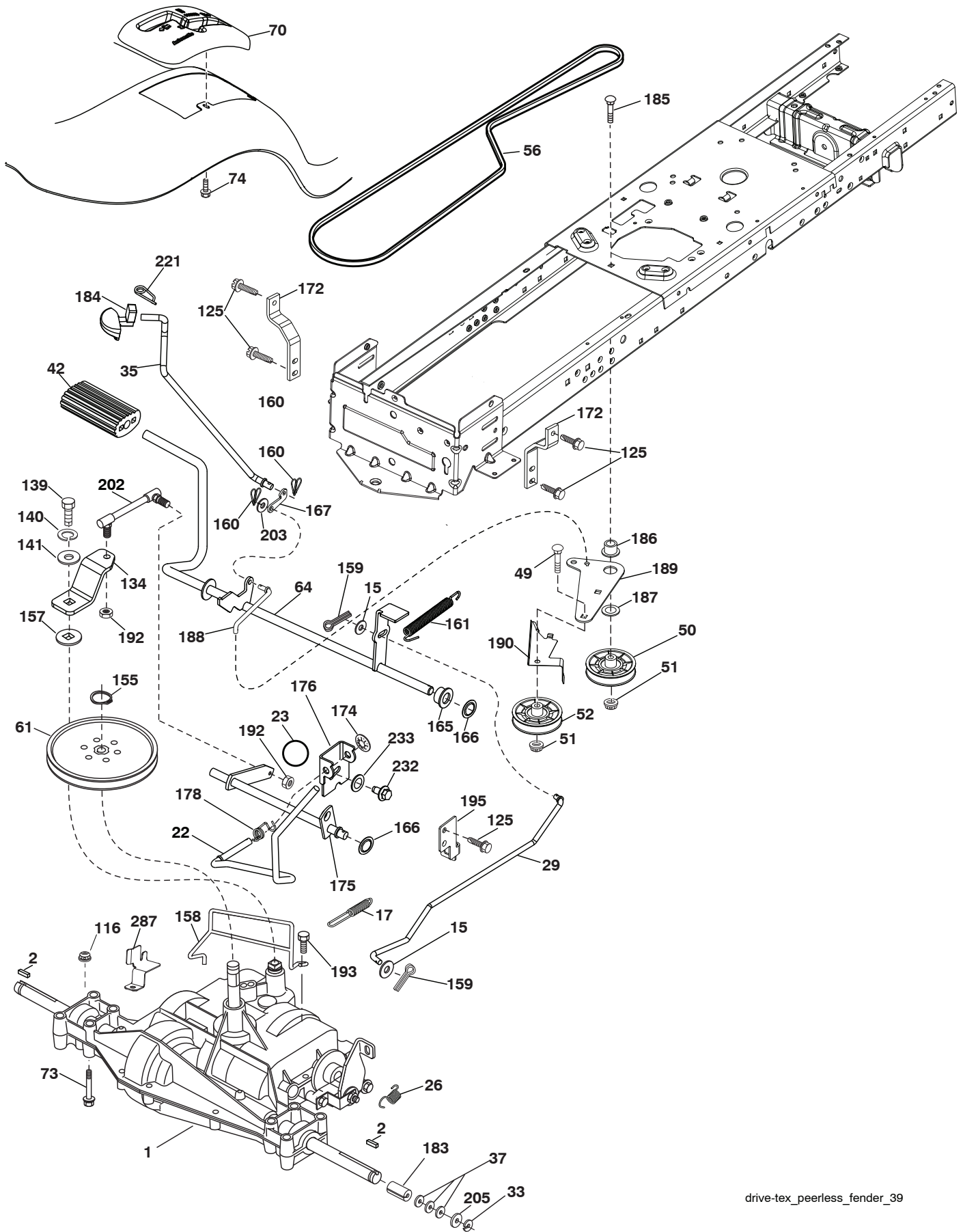

**TRACTOR - MODEL NO. PO12530LT (96042010500), PRODUCT NO. 960 42 01-05
DRIVE**

KEY NO.	PART NO.	DESCRIPTION	KEY NO.	PART NO.	DESCRIPTION
1	-----	Transaxle, Peerless 203-569	160	169484	Retainer Clip
2	123583X	Key Square	161	105709X	Spring, Return, Clutch
15	19131316	Washer 13/32 x 13/16 x 16 Ga.	165	196212	Busing Shaft Brake Hand Control
17	197297	Spring, Brake	166	429164	Nut Push .625
22	197660	Rod Shift	167	405257	Latch Brake Parking
23	106933X	Knob	172	197657	Strap Torque LH
26	197455	Spring Brake RTN	174	197289	Nut Push
29	197267	Rod, Brake	175	197858	Shaft Asm Shift
33	12000001	Ring E	176	196214	Arm Clevis Rod Shift
35	197722	Rod, Brake, Park	178	197456	Spring Shift
37	121749X	Washer 25/32 x 1-1/4 x 16 Ga.	183	137057	Spacer, Axle
42	8883R	Cover, Foot Pedal	184	198403X505	Handle Parking Brake
49	72110614	Bolt	185	72110622	Bolt
50	194327	Pulley Idler Flat	186	194321	Spacer Retainer
51	73900600	Lock Nut 3/8-16	187	19133210	Washer
52	194326	Idler V-Groove	188	194323	Link Clutch Ground Drive
56	138255	V-Belt, Drive	189	194317	Bellcrank Ground Drive
61	165999	Pulley Transaxle	190	194318	Keeper Bellcrank Ground Drive
64	196200	Shaft Asm. Pedal Brake Control	192	150360	Nut Lock Center 1/4-28
70	429581X428	Console	193	17060512	Screw 5/16-18 x 3/4
73	74490544	Bolt 5/16-18 Gr. 5	195	197332	Bracket Brake Rod
74	142432	Screw 1/4 x 1/2	202	197859	Link Shift
116	73900500	Nut Lock Hex Flange 5/16-18	203	19111116	Washer 11/32 x 11/16 x 16 Ga.
125	17000512	Screw 5/16-18 x 3/4	205	121748X	Washer 25/32 x 1-5/8 x 16 Ga.
134	197857	Arm Shift	221	403187	Retainer Spring Clip Handle
139	74550412	Bolt 1/4-20 unf Gr. 8 w/Patch	232	74780716	Bolt 7/16-14 x 1 Gr. 5
140	10040400	Washer Lock Hvy Helical 1/4	233	405296	Washer Serrated
141	19091210	Washer 9/32 x 3/4 x 10 Ga.	287	421648	Keeper Pulley T/A
155	12000028	Ring Retainer			
157	105701X	Washer Plate Shf			
158	194352	Keeper T/A			
159	76020412	Pin Cotter 1/8 x 3/4			

NOTE: All component dimensions given in U.S. inches
1 inch = 25.4 mm

**TRACTOR - MODEL NO. PO12530LT (96042010500), PRODUCT NO. 960 42 01-05
ENGINE**

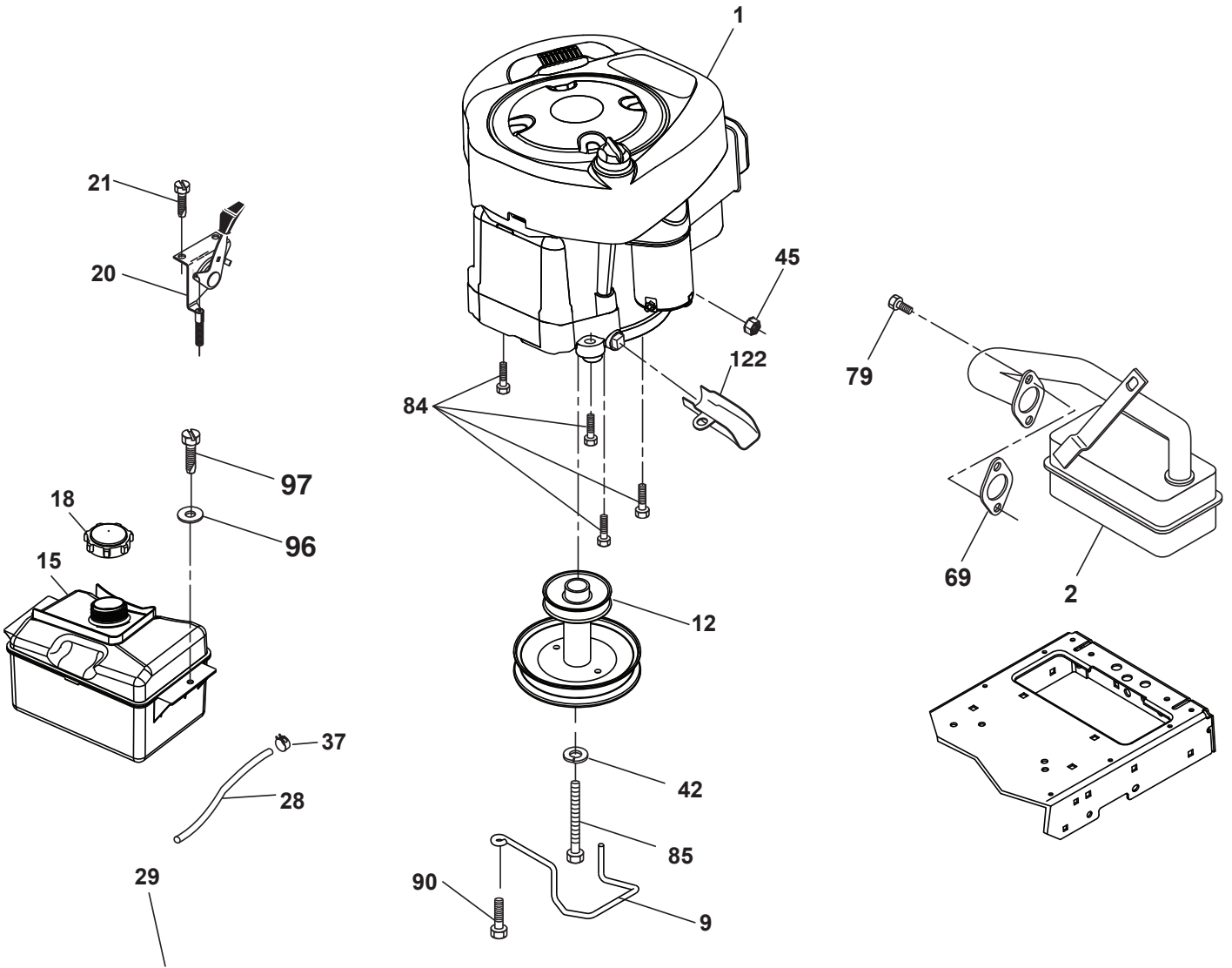

OPTIONAL EQUIPMENT
Spark Arrester

engine-tex_BS_30

TRACTOR - MODEL NO. PO12530LT (96042010500), PRODUCT NO. 960 42 01-05 ENGINE

KEY NO.	PART NO.	DESCRIPTION
1	-- ----	Engine Briggs Model No. 219807-0389-B1
2	179758	Muffler
9	194319	Keeper Belt Engine
12	140186	Pulley Engine
15	407545	Tank Fuel 1.5
18	430220	Cap
20	170545	Control Throttle
21	416358	Screw #10 x 0.750
28	401137	Fuel Line
29	137180	Spark Arrester Kit
37	123487	Clamp Hose
42	10040700	Washer Lock 7/16
45	73510400	Nut Keps Hex 1/4-20 unc
69	165291	Gasket
79	192334	Screw 5/16 - 18 x .75
84	17060620	Screw 3/8-16 x 1-1/4
85	71170764	Bolt Hex 7/16-20 x 4 Gr. 5
90	17000616	Screw 3/8-16 x 1
96	19091416	Washer 9/32 x 7/8 x 16 Ga.
97	17670412	Screw 1/4-20 x 3/4
122	421922	Extension Drain Oil

NOTE: All component dimensions given in U.S. inches.
1 inch = 25.4 mm

For engine service and replacement parts, call the toll free number for your engine manufacturer listed below:

Briggs & Stratton 1-800-233-3723

Engine Power Rating Information

The gross power rating for individual gas engine models is labeled in accordance with SAE (Society of Automotive Engineers) code J1940 (Small Engine Power & Torque Rating Procedure), and rating performance has been obtained and corrected in accordance with SAE J1995 (Revision 2002-05). Torque values are derived at 3060 RPM; horsepower values are derived at 3600 RPM. Actual gross engine power will be lower and is affected by, among other things, ambient operating conditions and engine-to-engine variability. Given both the wide array of products on which engines are placed and the variety of environmental issues applicable to operating the equipment, the gas engine will not develop the rated gross power when used in a given piece of power equipment (actual "on-site" or net power). This difference is due to a variety of factors including, but not limited to, accessories (air cleaner, exhaust, charging, cooling, carburetor, fuel pump, etc.), application limitations, ambient operating conditions (temperature, humidity, altitude), and engine-to-engine variability. Due to manufacturing and capacity limitations, Briggs & Stratton may substitute an engine of higher rated power for this Series engine.

TRACTOR - MODEL NO. PO12530LT (96042010500), PRODUCT NO. 960 42 01-05
STEERING

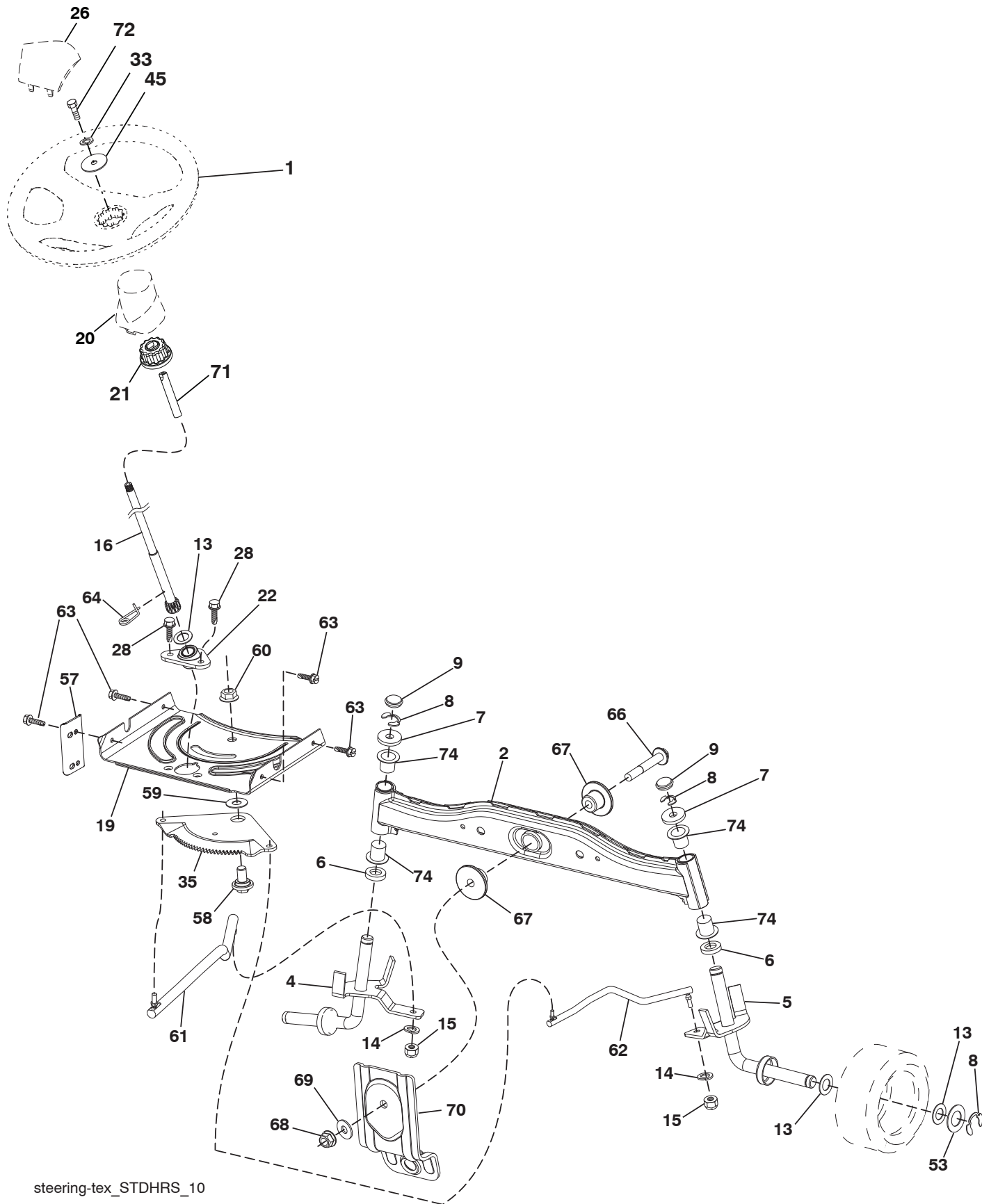

steering-tex_STDHRS_10

**TRACTOR - MODEL NO. PO12530LT (96042010500), PRODUCT NO. 960 42 01-05
STEERING**

KEY NO.	PART NO.	DESCRIPTION
1	414803X428	Wheel, Steering
2	418168	Axle Asm., Front
4	416845	Spindle Asm., LH
5	416846	Spindle Asm., RH
6	6266H	Washer Thrust 0.75 x 1.23
7	121748X	Washer 25/32 x 1-5/8 x 16 Ga.
8	1200029	Ring, Clip #T5304-75
9	121232X	Cap, Spindle
13	121749X	Washer 25/32 x 1-1/4 x 16 Ga.
14	10040600	Washer Lock 3/8
15	73540600	Nut, Crown Lock 3/8-24 unf
16	429374	Shaft Steering
19	194729	Plate Steering
20	198375X428	Boot, Steering
21	186737	Adapter, Wheel Steering
22	420537	Support, Strg. Lower
26	414854X428	Insert, Wheel Steering
28	17000612	Screw 3/8-16 x 3/4
33	10040500	Washer Lock 5/16
35	194732	Gear, Sector Plate
45	19113812	Washer 11/32 x 2-3/8 x 12 Ga.
53	188967	Washer Hardened.793x1.637x.060
57	407465	Bracket Upstop
58	194747	Bolt Shoulder Sector Pivot CFM
59	194748	Washer Thrust Sector Steering
60	73971000	Nut Flange Lock 5/8-11
61	194740	Draglink, LH
62	194741	Draglink, RH
63	17000512	Screw 5/16-18 x 3/4
64	199849	Retainer Clip Spring Steering
66	71020748	Bolt Hex Fghd 7/16-14 x 3 Serr
67	194737	Bushing PM Front Axle
68	73900700	Nut Lock Flange 7/16-14 Gr. 5
69	199162	Washer 1.5 x .505 x .118
70	417065	Bracket Deck Susp. Front
71	190752	Shaft Ext. Steering
72	428982	Bolt 5/16-18 x 4 w/Patch
74	3366R	Bearing

NOTE: All component dimensions given in U.S. inches
1 inch = 25.4 mm

TRACTOR - MODEL NO. PO12530LT (96042010500), PRODUCT NO. 960 42 01-05

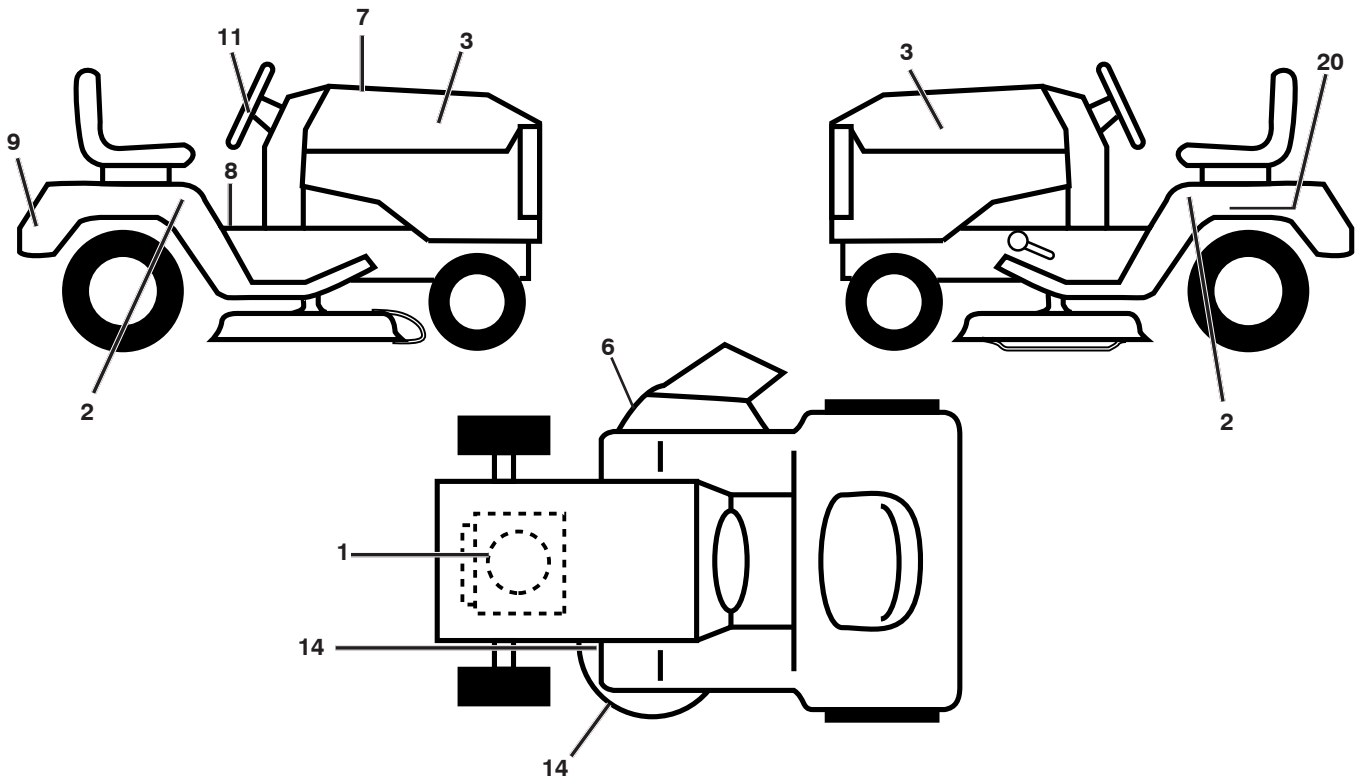

KEY NO.	PART NO.	DESCRIPTION
1	408813	Decal Engine HP
2	433818	Decal, Fender RH/LH
3	431983	Decal Hood
6	431912	Decal Warning, Keep Hand Away
7	431986	Decal Replacement Parts
8	411658	Decal Fender Warn S/F
9	425112	Decal Fender Logo
11	431982	Decal Ins Strg Whl

KEY NO.	PART NO.	DESCRIPTION
14	421543	Decal V-Belt Schematic
20	145005	Decal Bat Dan/Psn
--	193226X428	Pad Footrest LH
--	193227X428	Pad Footrest RH

WHEELS AND TIRES

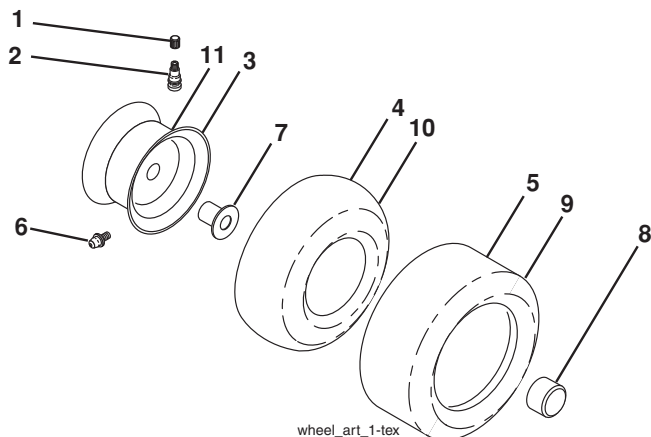

KEY NO.	PART NO.	DESCRIPTION
1	59192	Cap Valve Tire
2	65139	Stem Valve
3	421554X471	Rim Asm Front
4	421652	Tube Front (Service Item Only)
5	123410X	Tire F T
6	278H	Fitting Grease (Front Wheel Only)
7	9040H	Bearing Flange (Front Wheel Only)
8	104757X421	Cap Axle Blk 1 50 x 1 00
9	106230X	Tire R T
10	7154J	Tube Rear (Service Item Only)
11	421533X471	Rim Asm 8" Rear Service
--	144334	Sealant, Tire (10 oz. Tube)

NOTE: All component dimensions given in U.S. inches
1 inch = 25.4 mm

TRACTOR - MODEL NO. PO12530LT (96042010500), PRODUCT NO. 960 42 01-05 SEAT

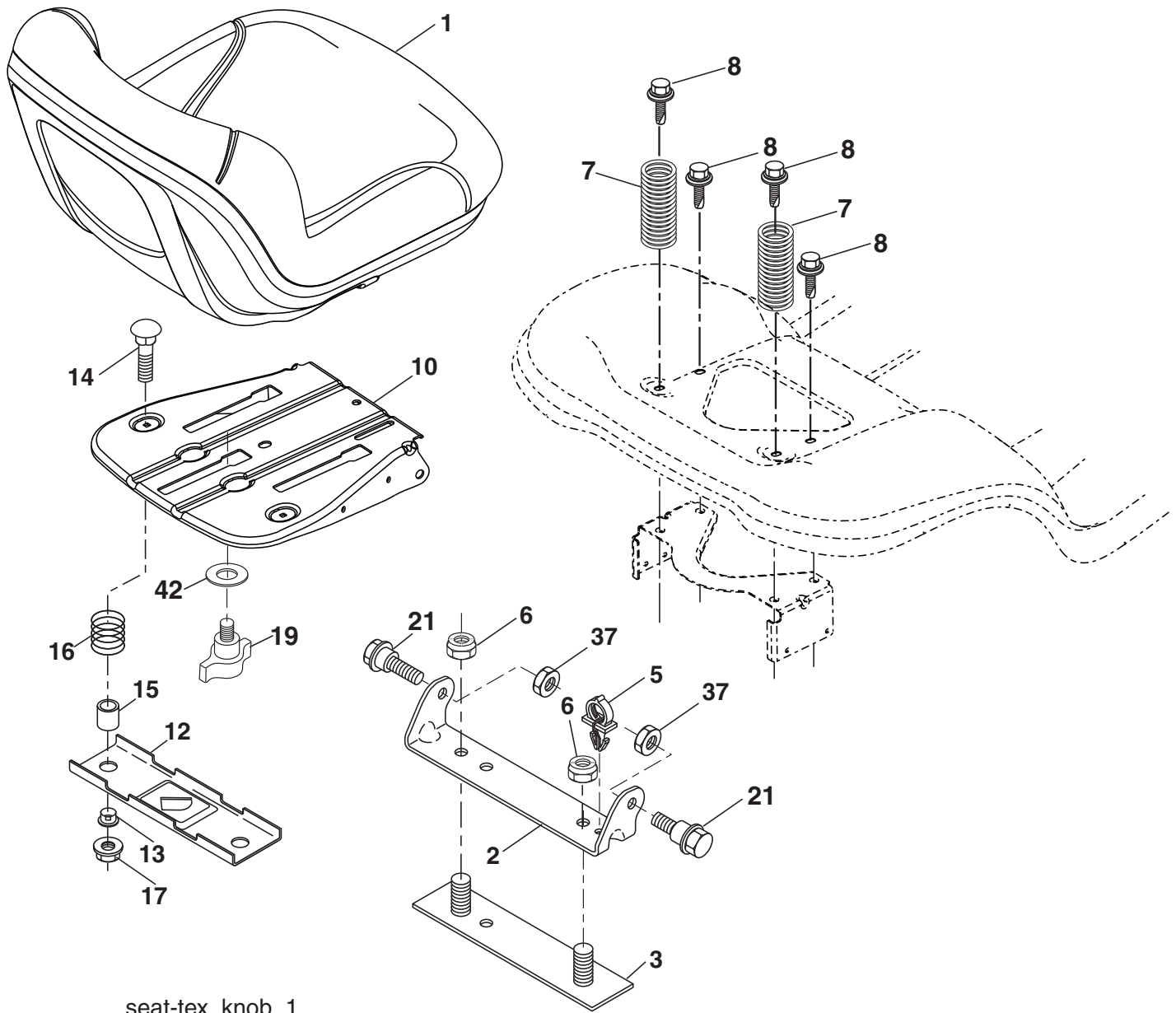

seat-tex_knob_1

KEY NO.	PART NO.	DESCRIPTION	KEY NO.	PART NO.	DESCRIPTION
1	403017	Seat	15	134300	Spacer Split
2	180166	Bracket Pivot Fender	16	123740X	Spring CPRSN Plate SW 1.310 Ga.
3	140675	Strap, Asm Fender	17	123976X	Nut Lock 1/4 Gr.5
5	145006	Clip Push-In Hinged	19	199372	Knob Seat
6	73800600	Nut, Lock w/Ins. 3/8-16 unc	21	171852	Bolt, Shoulder 5/16-18
7	124181X	Spring, Seat Cprsn	37	73800500	Nut, Lock 5/16-18 unc
8	171877	Bolt 5/16-18 unc x 3/4 w/Sems	42	199371	Washer Cup Seat
10	199180	Pan, Seat			
12	199370	Bracket Seat Mounting			
13	121248X	Bushing Snap			
14	72050412	Bolt 1/4 - 20 X 1-1/2			

NOTE: All component dimensions given in U.S. inches
1 inch = 25.4 mm

**TRACTOR - MODEL NO. PO12530LT (96042010500), PRODUCT NO. 960 42 01-05
MOWER DECK**

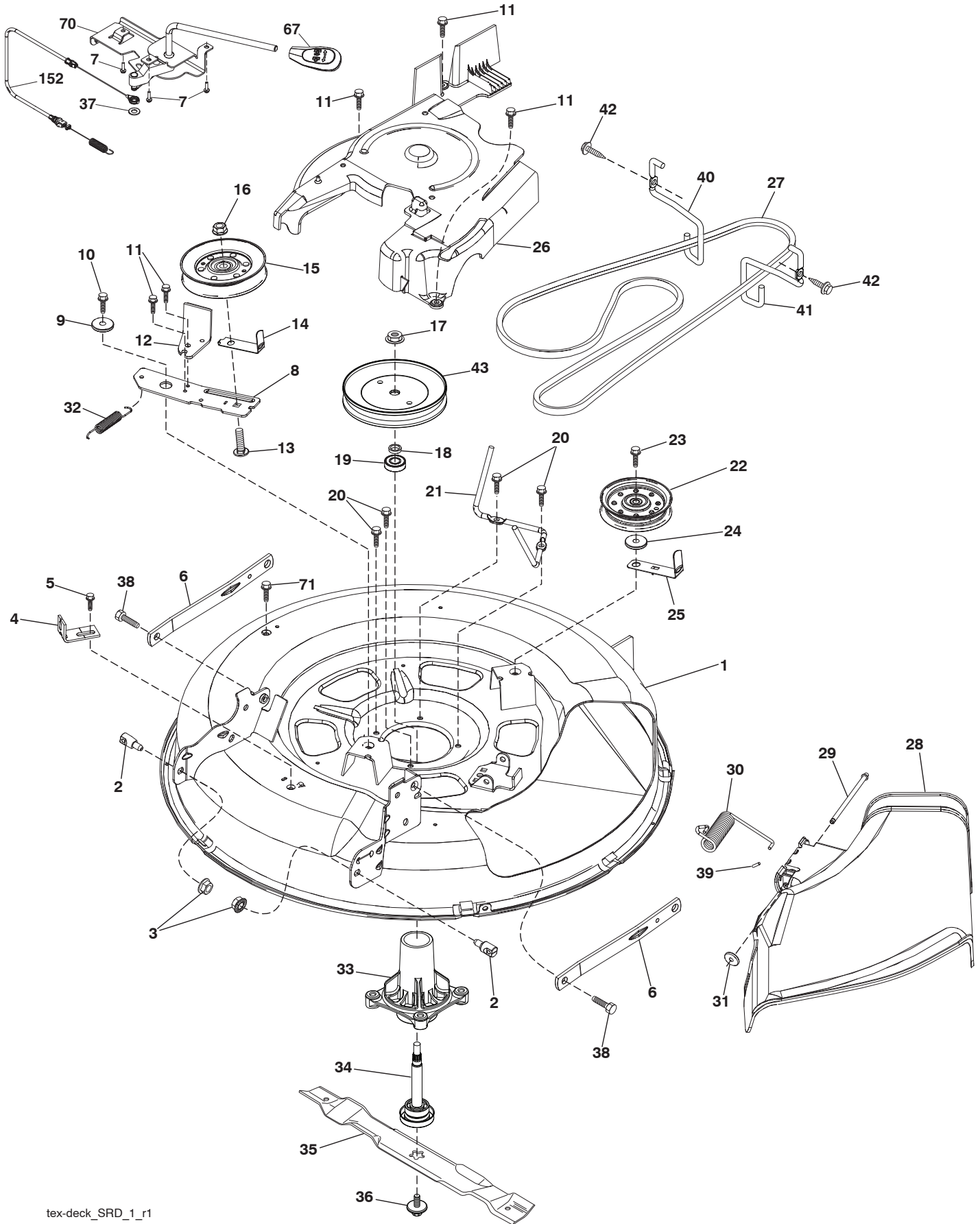

**TRACTOR - MODEL NO. PO12530LT (96042010500), PRODUCT NO. 960 42 01-05
MOWER DECK**

KEY NO.	PART NO.	DESCRIPTION	KEY NO.	PART NO.	DESCRIPTION
1	419272	Deck Weldment 30"Srd	32	401872	Spring Return Deck 38/46"
2	195161	Stud Fastner w/'d'anti-Rotatio	33	187281	Housing Mandrel 4pt Service
3	73900500	Nut Lock Hex Flange 5/16 - 18	34	192872	Shaft Asm Mndrl N/Greaseable 38
4	417645	Bracket Clutch Cable	35	419274	Blade Mower Bagging Srd
5	17000510	Bolt 5/16-18	36	193003	Bolt/Washer Asm 7/16 - 20 unf
6	418863	Arm Susp Mower Rear Srd	37	19131316	Washer 13/32 x 13/16 x 16 Ga.
7	416358	Screw #10 x 0.750 BOS Thread	38	196539	Bolt Shoulder
8	420252	Arm Idler 30"Srd	39	105304X	Cap Sleeve
9	199092	Spacer Retainer	40	419270	Keeper Belt Engine LH
10	17000616	Screw 3/8 - 16 X 1 Smgml Tap/R Blk	41	419265	Keeper Belt Engine RH
11	137729	Screw Thd Roll 1/4 - 20 X 5/8	42	17000612	ScrewHexwsh THDR3/8-16x3/4BL
12	199470	Arm Brake Mower 38" RH Tex	43	416877	Pulley Mandrel 6 5 Pd 30"
13	72110612	Bolt Carr Sh 3/8 - 16 X 1 - 1/2 Gr5	67	198398X505	Handle clutch cable
14	156085	Keeper Belt Idler	70	198332	Clutch Asm. Manual
15	146763	Pulley Idler V-Groove Dim 4.25	71	17670608	Screw 3/8-16 x 1/2
16	73900600	Nut Lock FIG 3/8 - 16 unc	152	408714	Manual Clutch Cable
17	400234	Nut Flange Lock Top	--	192870	Mandrel Assembly (Includes Hous- ing, Shaft Assembly, And Bearing Only -Pulley/Nut/Washer And Blade Bolt/Washers Not Included) Replacement Mower Complete
18	187690	Washer Spacer Mandrel			
19	110485X	Bearing Ball Mandrel			
20	173984	Screw Thd Roll Dod Pt Hex			
21	416910	Keeper Belt Mandrel 30"	--	431888	
22	193198	Pulley Idler Flat Unplated			
23	17490628	Screw Thdrol 3/8 - 16 X 1-3/4			
24	19132012	Washer 13/32 X 1 - 1/4 X 12 Ga			
25	420253	Keeper Belt 30"Srd			
26	420255	Cover Mandrel Mwr 30"Black			
27	419271	Drive, Belt			
28	417344	Deflector			
29	420895	Hinge Pin			
30	197026	Spring Torsion			
31	110452X	Nut Push			

NOTE: All component dimensions given in U.S. inches
1 inch = 25.4 mm

**TRACTOR - MODEL NO. PO12530LT (96042010500), PRODUCT NO. 960 42 01-05
MOWER LIFT**

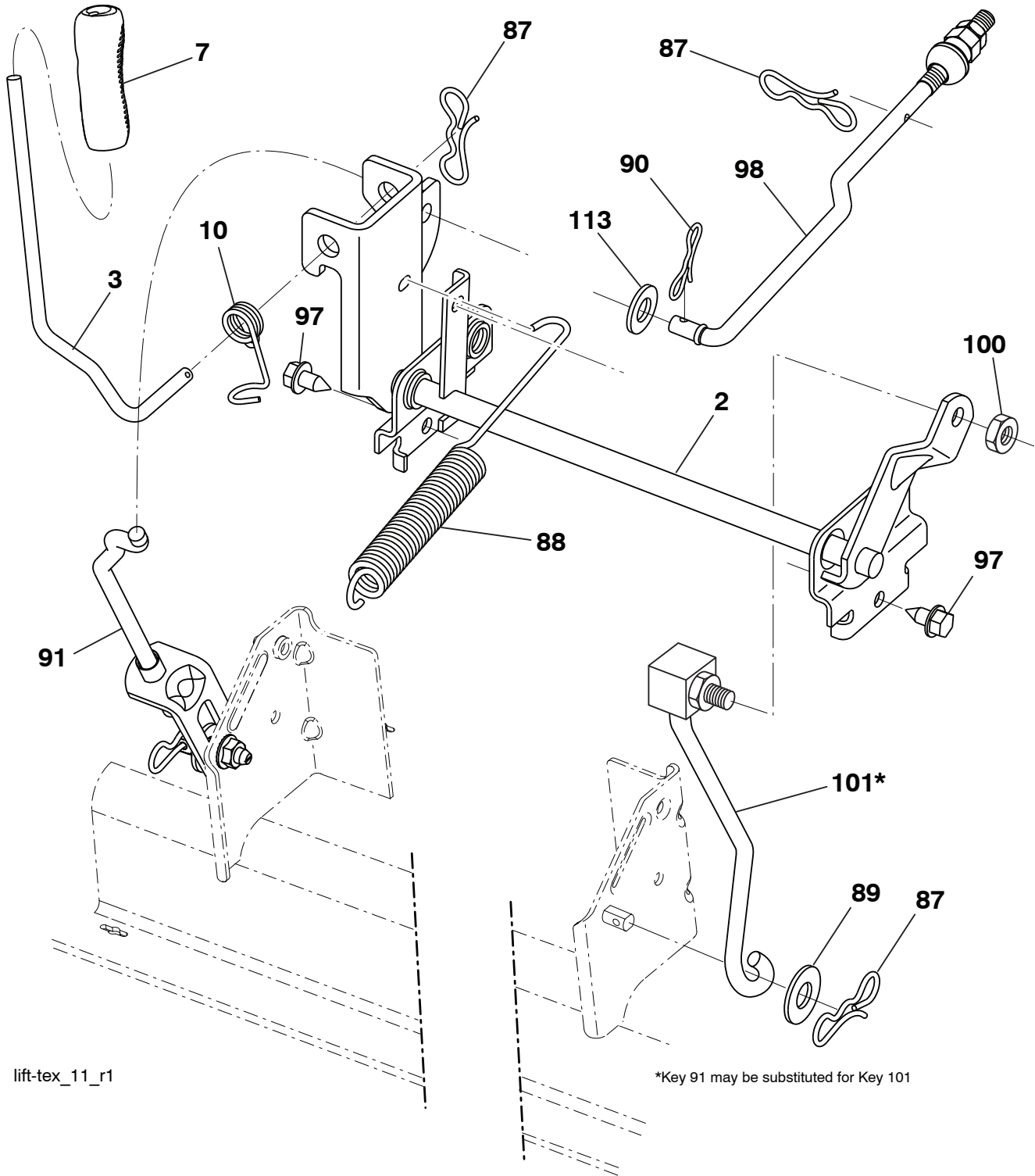

KEY NO.	PART NO.	DESCRIPTION
2	422027	Shaft Asm., Cross Lift
3	195231	Lever Asm., Lift RH
7	196492X428	Grip, Lever
10	196314	Spring Torsion
87	194209	Pin Cotter 7/16 Bow Tie Lock
88	410710	Spring Lift Assist
89	19191912	Washer Clear Zinc
90	194208	Pin Cotter 5/16 Bow Tie Lock
91	195181	Link Lift Susp Mower Rear

KEY NO.	PART NO.	DESCRIPTION
97	17000612	Screw 3/8-16 x .75 Smgml Tap/R.Z
98	195264	Link Lift Susp. Front Mower
100	73930600	Nut Centerlock 3/8 -16 unc
101	407003	Link Asm Lift Fixed
113	19171912	Washer 17/32 x 1-3/16 x 12 Ga.

NOTE: All component dimensions given in U.S. inches
1 inch = 25.4 mm