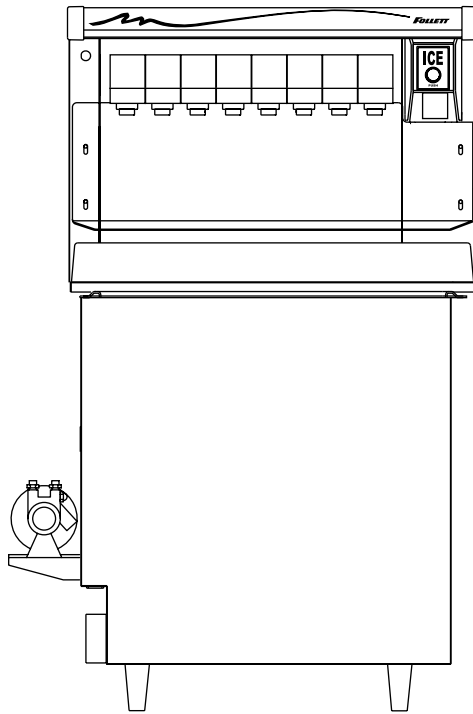


# VU155K Integral Cold Carbonation Series Ice and Beverage Dispensers

Order parts online  
[www.follettice.com](http://www.follettice.com)

Installation, Operation and Service Manual

Service numbers above B50000



**Following installation, please forward this manual  
to the appropriate operations person.**



# Table of contents

<b>Welcome to Follett Corporation</b> .....	4
<b>Important cautions</b> .....	4
<b>Specifications</b> .....	5
<b>Installation</b> .....	7
Installing dispenser in counter .....	7
Field wiring diagrams .....	8
Installing optional icemaker .....	8
Connecting beverage lines .....	9
<b>Operation</b> .....	9
How the dispenser works .....	9
Cleaning .....	10
<b>Service</b> .....	12
Dispense chute cover removal .....	12
Auger motor assembly removal .....	12
Gate assembly removal .....	12
Auger and auger tube removal .....	12
Dispenser wheel removal .....	12
Wiring diagrams .....	13
<b>Troubleshooting</b> .....	14
<b>Replacement parts</b> .....	17

## **Follett Corporation Equipment Return Policy**

Follett equipment may be returned for credit under the following conditions:

1. The equipment is new and unused.
2. A return authorization number has been issued by customer service.
3. Follett receives the equipment at the factory in Easton, PA within 30 days of the issue of the return authorization number.
4. The equipment must be returned in Follett packaging. If the packaging has been damaged or discarded, Follett will forward, at the customer's expense, new packaging.

**Note:** Return freight charges are the responsibility of the customer. If equipment is returned and is damaged because of improper packaging, Follett Corporation will not be held responsible.

Credit will be issued when:  
The equipment has been inspected by Follett and deemed suitable to be returned to stock.

**Note:** A 15% restocking charge will be deducted from the credit. If the cost to return the product to stock exceeds 15%, the actual cost will be deducted.

# Welcome to Follett

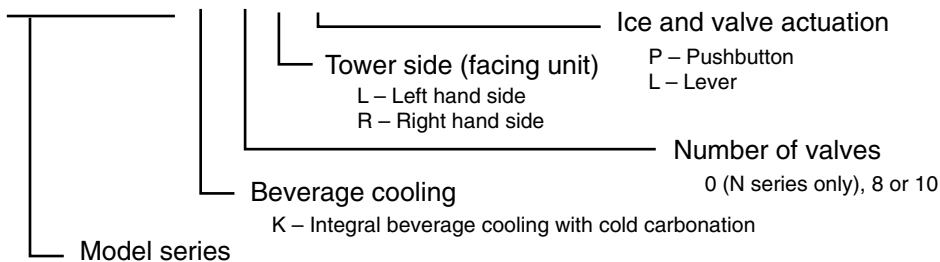
Follett ice dispensers enjoy a well-deserved reputation for excellent performance, long-term reliability and outstanding after-the-sale support. To ensure that this dispenser delivers that same degree of service, we ask that you take a moment to review this manual before beginning the installation of the dispenser. Should you have any questions or require technical help at any point, please call our technical service group, (800) 523-9361 or (888) 2-FOLLETT or (610) 252-7301.

## Before you begin

After uncrating and removing all packing material, inspect the equipment for concealed shipping damage. If damage is found, notify the shipper immediately and contact Follett Corporation so that we can help in the filing of a claim, if necessary.

Check your paperwork to determine which model you have. Follett model numbers are designed to provide information about the type and capacity of Follett ice dispensing equipment. Following is an explanation of the different model numbers in the VU155K series.

## VU155K8LP



### Important cautions

**Storage area of dispenser contains mechanical, moving parts. Keep hands and arms clear of this area at all times. If access to this area is required, power to unit must be disconnected first.**

**Ice is slippery. Maintain counters and floors around dispenser in a clean and ice-free condition.**

**Ice is food. Follow recommended cleaning instructions to maintain cleanliness of delivered ice.**

**Always disconnect power before cleaning or servicing the dispenser.**

**Failure to remove all sanitizer may result in health hazard.**

**Follett manual load dispensers can accommodate most cube/cubelet ices up to 1" square, or Follett compressed nugget ice. Crushed, flake, bagged, nugget or congealed ice cannot be used. Use of these ices can jam dispenser and void warranty. Separate any "waffle-like" sections of cubes before adding to dispenser. For ice compatibility questions, please call Follett customer service at (800) 523-9361 or (888) 2-FOLLETT or (610) 252-7301.**

# Specifications

## Electrical

Each icemaker and dispenser require a separate circuit with with electrical disconnect within 10 ft (6m). Equipment ground required. Standard electrical – 115V, 60Hz, 1 phase. Maximum dispenser fuse – 15 amps, Maximum icemaker fuse – 20 amps each.

<b>Model number</b>	<b>Icemaker amperage</b>	<b>Dispenser amperage</b>
VU155K series	11.0 amps ea	8.7 amps

## Plumbing

**Dispenser**      3/4" PVC pipe nipple for bin drain  
3/4" PVC pipe nipple for drain pan drain  
1" ID hose for beverage bath drain

### **Beverage connections**

1/4" ID syrup beverage hose  
3/8" 45° flair fitting for water inlet  
1/4" ID CO<sub>2</sub>  
3/8" ID plain water inlet

**Note:** Set CO<sub>2</sub> pressure to 75 psi and syrup pressure to 60 psi.

Drains should be hard piped and insulated. Maintain at least 1/4" per foot (6mm per 304mm run) slope on drain line run.

Water disconnect within 10 feet (3m) of dispenser is suggested for automatic load units.

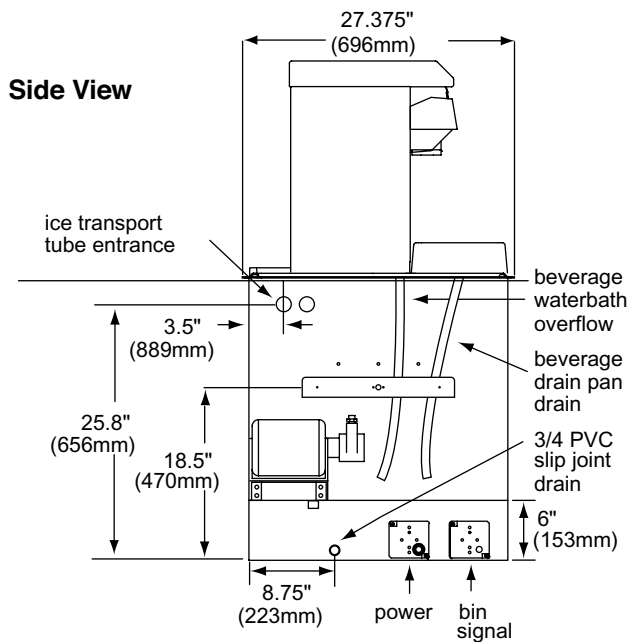
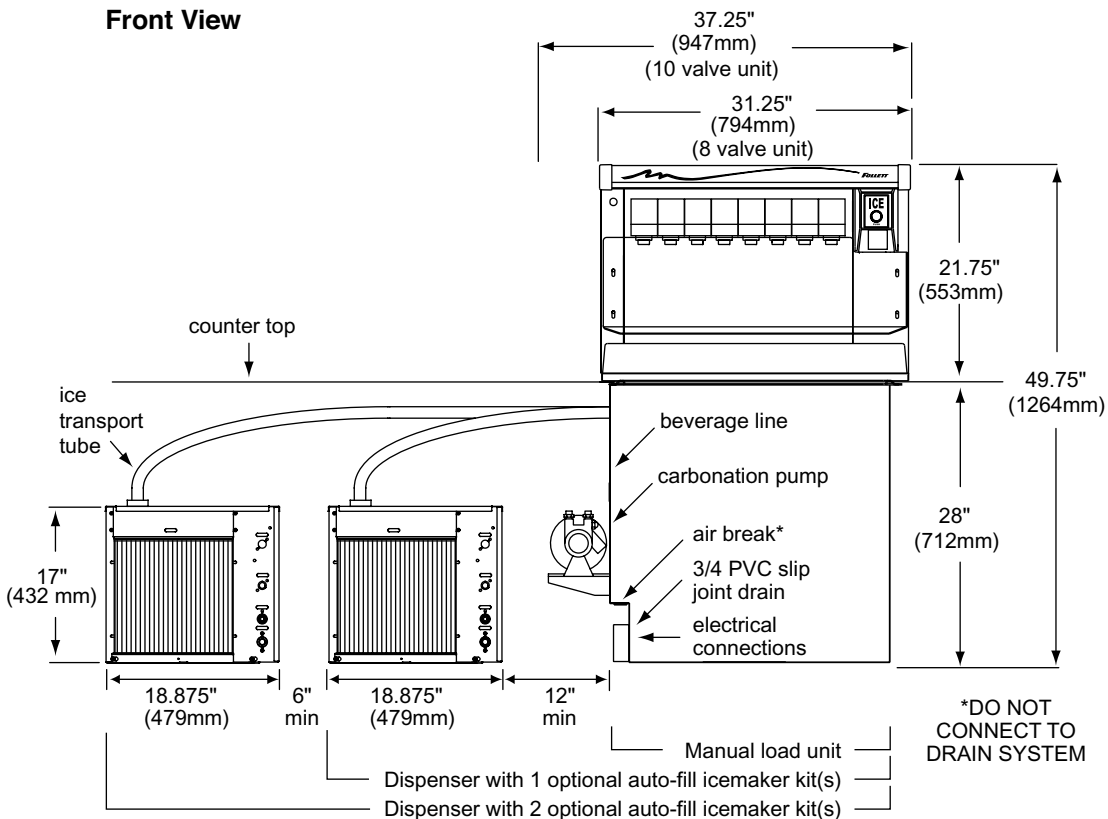
Follett recommends use of a Follett model AFSYSTEMFL4S water filter on icemakers connected to automatic fill dispensers.

**Icemaker**      Refer to detailed specifications in icemaker installation manual packed with icemaker

# Dimensions and clearances

## Required clearances

- 51" (1295mm) minimum above counter for installation if dispenser will be dropped into counter
- 36" (915mm) minimum above counter for all units after installation for auger cleaning and servicing
- 12" (305mm) minimum on side opposite ice chute for service
- 12" (305mm) minimum on ice chute side if ice transport tube enters this side
- 12" (305mm) minimum between dispenser side(s) and optional icemaker(s)



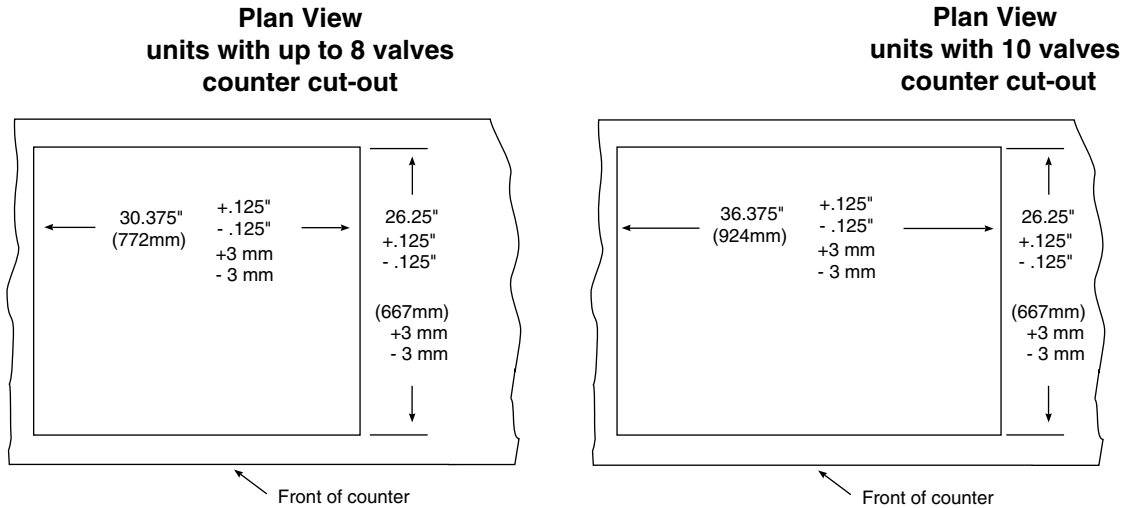
# Installation

## Installing dispenser in counter

**Note:** All dispensers must be supported from below with supplied 6" – 9" (153 – 229mm) adjustable leg accessory, or equivalent. Do not hang dispenser on flange.

All dispensers must be installed level in both directions to ensure proper operation.

1. Check that dispenser location meets all requirements in this manual and cut counter as shown.



2. Place support blocks in cabinet to raise dispenser to a height of 12" (305mm).
3. Place dispenser in counter onto support blocks.
4. Attach adjustable legs to dispenser.
5. Remove support blocks and lower dispenser feet to floor.
6. Adjust legs for 1/8" (4mm) clearance between dispenser lip and countertop to verify there is no load on flange.
7. Apply a bead approximately 1/4" (6mm) in diameter of NSF-listed silicone sealant (Dow Corning RTV-732 or equivalent) around perimeter of dispenser where it meets counter. Smooth sealant to a 1/8" (4mm) radius.
8. Install a PVC drain line with at least a 1/4" per foot (20mm per 1m) slope. Insulate drain line to prevent condensation.

**Note:** Do not apply excessive heat if any sweating of fittings is necessary. Heat conduction through metal may melt threads in plastic drain.

Do not reduce drain line size or tie drains together.

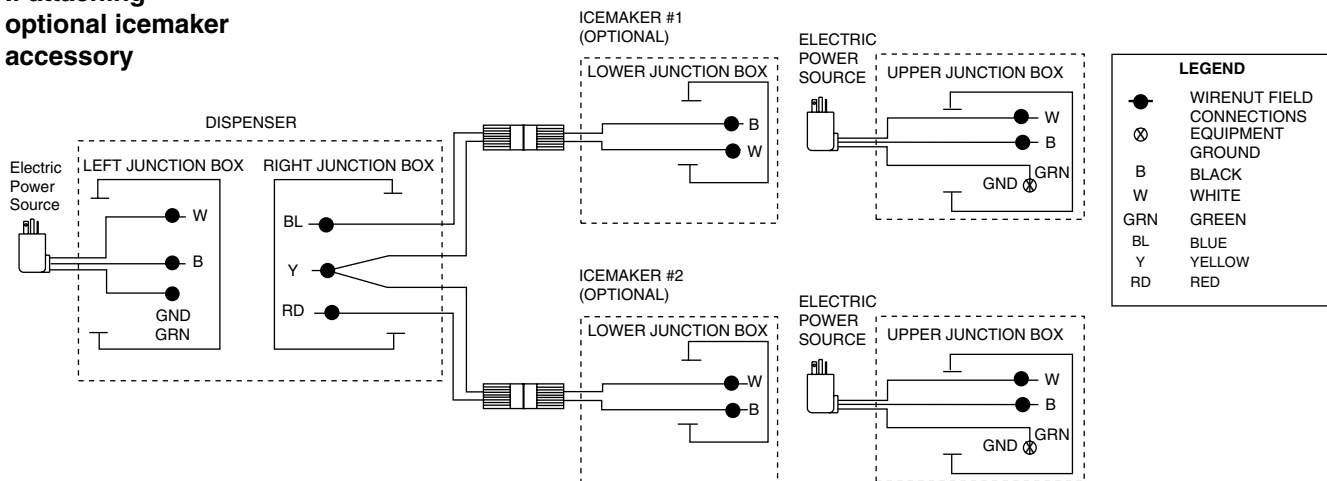
**Note:** See instruction enclosed with carbonator pump for detailed installation instructions.

9. Use supplied bolts and lock washers to attach carbonator pump assembly to side of dispenser opposite ice dispense tower. Tighten bolts securely.
10. Connect the 3/8" water line from the dispenser to the 3/8" male flare pump outlet connection.
11. Trace the pump power cord to identify the pump twist lock plug and connect to the female twist lock connector on the dispenser.
12. Make electrical connections in accordance with applicable wiring diagrams provided. Provide disconnects within 10 ft (3m) of dispenser and icemaker for servicing.

## Field wiring diagrams

**Note:** Field wiring diagrams are intended to aid electricians or technicians in understanding how equipment works. All field wiring must be installed in accordance with all local and NEC codes.

### If attaching optional icemaker accessory



## Installing optional auto-fill icemaker kit(s)

Correct installation of remote icemaker(s) is critical to proper performance of icemaker. Refer to installation manual packed with icemaker for important details on ice transport tube run, ventilation requirements and other installation requirements. Failure to comply with instructions may void warranty.

### To start and operate dispenser

1. Follow detailed cleaning instructions in service manual before operating dispenser.
2. On units with Follett integral ice water bath beverage cooling ("B" models) only, slowly pour water into ice water bath area to fill empty bath and submerge coils. Coils are submerged when water starts to flow out overflow drain. **DO NOT SPLASH WATER ON ELECTRICAL BOX.** Once filled with water, add ice to bath until ice covers top of water bath.
3. For manual load units, remove front drain pan or rear lid and fill storage area with approved ice.

**Note:** Follett manual load dispensers can accommodate most cube/cubelet ices up to 1" square, or Follett compressed nugget ice. Crushed, flake, bagged, nugget or congealed ice cannot be used. Use of these ices can jam dispenser and void warranty. Separate any "waffle-like" sections of cubes before adding to dispenser. For ice compatibility questions, please call Follett customer service at (800) 523-9361 or (888) 2-FOLLETT or (610) 252-7301.

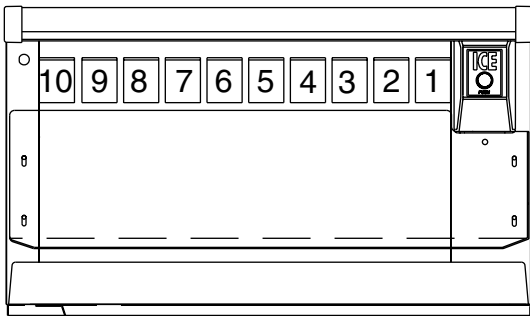
4. Turn power switch located on dispenser control box to ON position.
5. For automatic fill units, follow detailed instructions in icemaker installation section of installation manual, then turn icemaker (bin signal) switch(es) located on dispenser control box to ON position and begin to make ice.
6. When dispenser has at least 6" (153mm) of ice in storage area, test operation.



## Connecting beverage lines

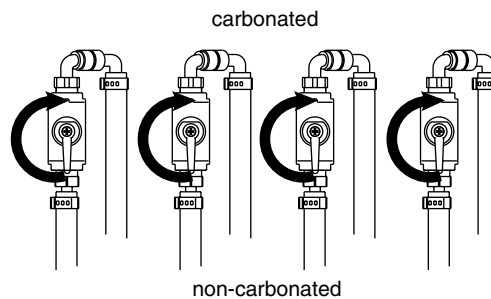
1. Connect syrup and water lines. Non-carbonated water line will be labeled “water”. Syrup lines are numbered and correspond to the valves as shown in drawing(s) below. Valve one is always next to ice tower.
2. The center 4 valves are pre-plumbed to both carbonated and non-carbonated water lines with the QuickCARB™ beverage manifold. Valves can be individually changed from a carbonated to a non-carbonated flavor with the flip of a lever (see below).
3. Clean and sanitize beverage lines according to cleaning instructions.

**Valve position #1 is always next to ice tower. Right-hand unit shown.**



**VU155B QuickCARB manifold**  
(see dispenser for model specific QuickCARB configuration)

### Rear View



## Operation

### How the dispenser works

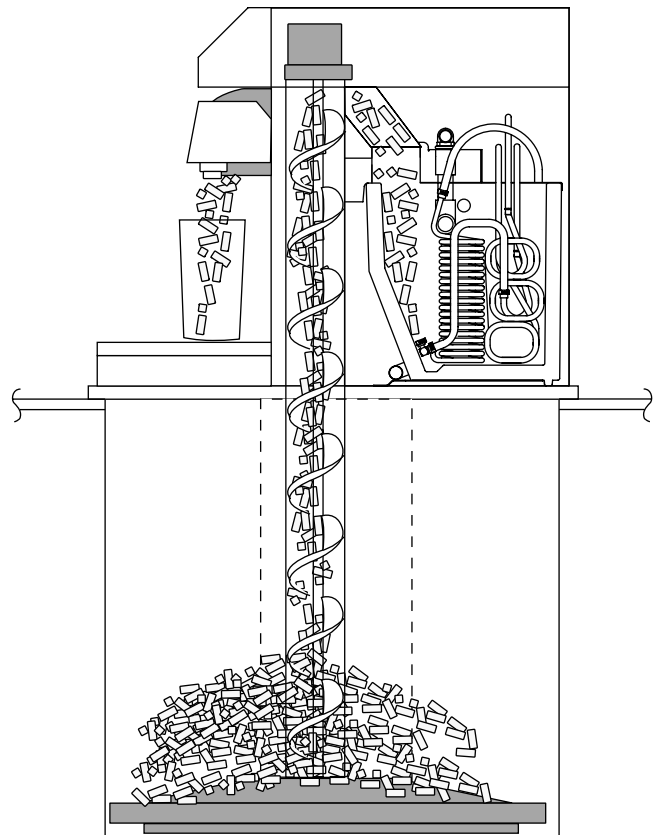
Follett's dispensers are available in automatic load configurations, fed from one or two Follett remote icemakers or manual load configurations (using ice from another source).

In all models, ice is stored below the counter in the dispenser storage area. When the dispense lever or button is pushed, the dispense motors are activated. This causes the wheel assembly in the storage area to turn, moving ice to the vertical auger assembly, which carries ice up to the dispense chute where it drops by gravity into the container.

In automatic load units, ice is manufactured in either one or two Follett remote icemakers. These icemakers may be located up to 20 ft (6m) away from the dispenser. Extruded ice is transported through a tube and pushed to the storage compartment of the dispenser. When the bin is filled, a bin thermostat shuts the icemaker off to avoid overfilling of the bin. The icemaker will restart after 20 minutes if the bin is calling for ice.

Units with integral ice water bath beverage cooling are equipped with a water bath timer circuit that activates the water bath pump for 35 minutes when ice lever or button is activated, or when the ice water bath warms up and calls for more ice.

### Ice movement



# Cleaning

Using solutions below, clean and sanitize storage area and beverage lines before starting unit and on a routine basis as noted below.

**Note:** Always disconnect power before cleaning dispenser.

Do not run plastic parts through a dishwasher.

**Solution A:** Combine 1 oz (250ml) bleach with 2 gal (8L) hot water or use Ecolab Mikro-chlor Cleaner per manufacturers instructions.

**Solution B:** Combine 1/4 oz (50ml) bleach with 2 gal (8L) hot water or use Ecolab Mikro-chlor Cleaner per manufacturers instructions.

**Note:** Cleaning solutions temperature must be at 75° – 125°F (24° to 52°C)

## Recommended cleaning prior to start up

### Cleaning ice storage area before use

1. Refer to disassembly instructions (see Service section) and remove dispense wheel from ice storage area.
2. Remove auger, auger tube and dispense mechanism.
3. Wipe all components and ice storage area with cleaning Solution A.
4. Rinse all components and ice storage area thoroughly with clear, potable water.
5. Wipe all components and ice storage area with sanitizing Solution B.

### Cleaning beverage lines

Prepare 6 gallons (23L) of cleaning Solution A. Fill a clean product tank with cleaning solution. Fill a second clean product tank with potable rinse water.

1. Disconnect all syrup lines from product containers.
2. Connect syrup line #1 to cleaning solution tank, pressurize tank to 20-50 psi, and dispense 1/2 gallon (2L) of solution into a suitable container from valve #1.
3. Connect syrup line #1 to rinse tank, pressurize tank to 20-50 psi, and dispense 3 gallons (11L) into a suitable container from valve #1.
4. Repeat this cleaning and rinsing for all syrup lines.
5. Remove diffusers and nozzles from valves, soak in cleaning solution, rinse well and reinstall.

### Sanitizing beverage lines

Prepare 6 gallons (23L) of sanitizing Solution B. Fill a clean product tank with this solution.

1. Connect one tank to syrup line #1. Dispense 1/2 gallon (2L) from valve #1.
2. Repeat for all remaining syrup lines, allowing sanitizing solution to remain in all circuit lines for 15 minutes.
3. Connect a clean, empty tank (pressurized to 50 psi) to each syrup line and blow out sanitizer by operating each valve.
4. Remove diffusers and nozzles from valves, soak in sanitizing solution for 15 minutes, rinse well and reinstall.
5. Reconnect all lines and dispense product through valves to purge any remaining sanitizer.

### **Recommended daily dispenser cleaning**

1. Remove all debris from drain pan.
2. Pour 1 gallon (4L) hot water into drain pan to keep drain lines clear.

### **Recommended weekly dispenser cleaning**

1. Remove drain pan and grille and wash with Solution A. Rinse thoroughly.
2. Remove nozzles and diffusers from valves, soak for at least 10 minutes in cleaning Solution A, rinse, sanitize with Solution B and reinstall.
3. Pour a solution of one cup (8oz/237ml) household bleach mixed with one gallon (3.8L) hot water into drain pan to help prevent algae growth in drain lines.

### **Recommended quarterly dispenser cleaning**

1. Remove top from dispenser and turn power switch to OFF position.
2. Remove ice from storage area.
3. Remove dispense chute cover, chute, auger motor assembly, auger and auger tube (see Service section).
4. Remove drain pan, grille and dispense wheel (see Service section).
5. Clean all components and bin storage area with Solution A, rinse thoroughly with clear water and sanitize with Solution B.
6. Remove nozzles and diffusers from valves, soak for at least 10 minutes in cleaning Solution A, rinse, sanitize with Solution B and reinstall.

### **For units with integral ice-water bath beverage cooling only:**

1. Remove dispenser lid and counter access panel opposite ice tower side.
2. Disengage service drain tube (on utility connection side of dispenser) from mounting bracket.
3. Pull bath service drain tube down through beverage line opening in counter and drain water bath into a bucket.
4. Use a bottle brush to clean coils with Solution A, rinse and sanitize with Solution B.
5. Reposition ice water bath drain tube in up position so water does not drain out.
6. Pour Solution A into ice water bath until it flows out of bath overflow drain.
7. Turn power ON to unit and dispense a small cup of ice to activate pump.
8. Allow pump to run for two minutes to clean pump and pump lines.
9. Turn power OFF.
10. Drain bath and replace drain tube in mounting bracket in up position to avoid siphoning water bath water.

### **Putting unit back in service after quarterly cleaning**

1. On units with integral beverage cooling, fill ice water bath with water until water spills out of bath overflow drain.
2. Reassemble components.
3. For manual load units, fill unit with an approved ice (see important cautions on page 4).
4. For automatic load units with R400A/W (R404A refrigerant) icemakers, turn bin signal switch(es) and dispenser power switch to ON position and allow storage area to fill.
5. Dispense and discard all ice, verifying dispenser is functioning properly.

### **Recommended quarterly cleaning of optional icemaker.**

Units equipped with optional icemakers require cleaning of icemaker system at least every six months, and more often if local water conditions dictate. Failure to clean icemaker system will result in decreased performance and potential damage to icemaker. Refer to Icemaker Installation, Operation and Service Manual.

# Service

## Dispense chute cover removal

1. Remove top cover.
2. Push chute cover up vertically to slip off holding tab.
3. After clearing tab, pull chute cover forward to remove.

## Auger motor assembly removal

1. Remove top cover.
2. Remove one thumbnut on rear of motor bracket.
3. Lift motor bracket and motor up, unplug electric quick disconnects and remove.

## Dispense mechanism assembly removal (Fig. 2)

1. Remove top cover.
2. Remove chute cover (see above).
3. Remove auger motor assembly (see above).
4. Remove quick release pins from the ice chutes and gates, then unplug wires from solenoids.
5. Lift dispense mechanism up and off auger tube.

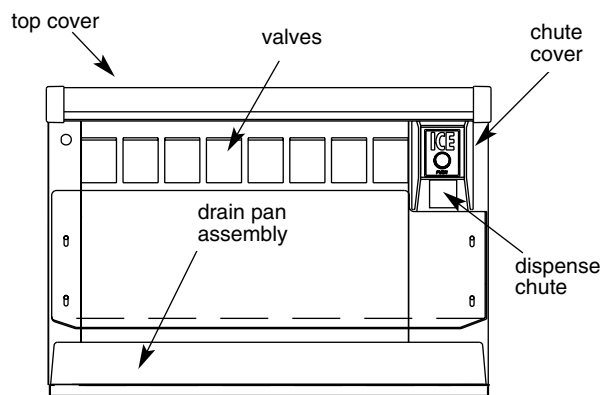
## Auger and auger tube removal (Fig. 3)

1. Remove auger motor and dispense mechanism assembly (see above).
2. Pull auger upward to clear auger tube.
3. Lift auger tube upward to clear dispenser top.
4. Slide tube and bearing plate through auger tube gasket.

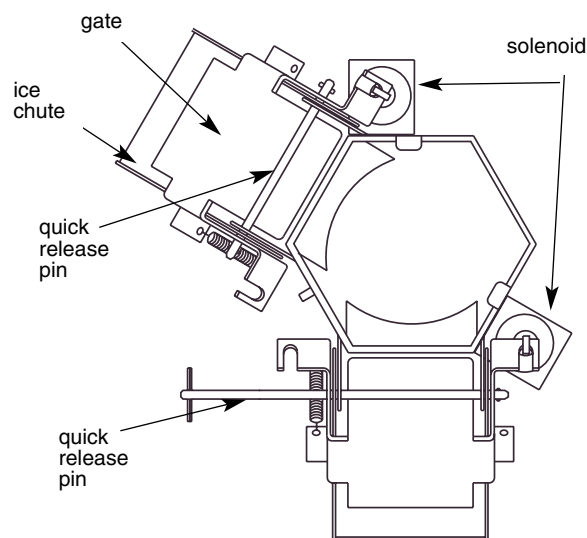
## Dispense wheel removal

1. Remove drain pan assembly and bin access cover.
2. Remove center thumbnut and threaded rod on dispense wheel assembly and lift wheel out front access opening.

**Fig. 1** RH, 8-valve unit  
Front View

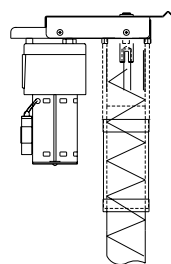


**Fig. 2** Dispense assembly, top view  
(RH unit with bath shown)

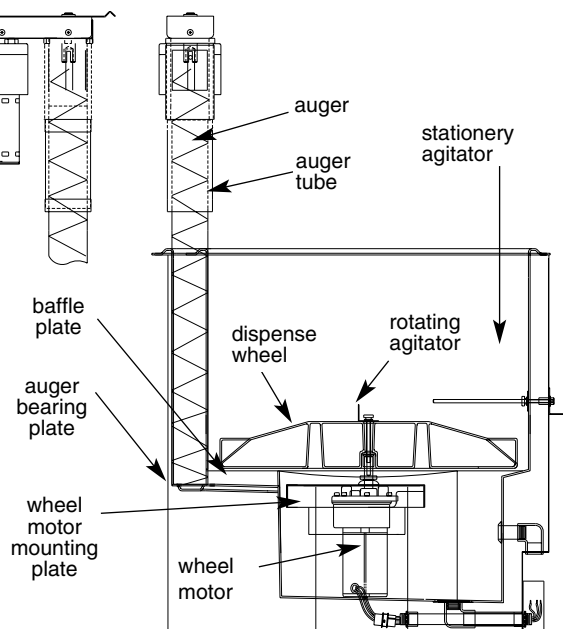


**Fig. 3**

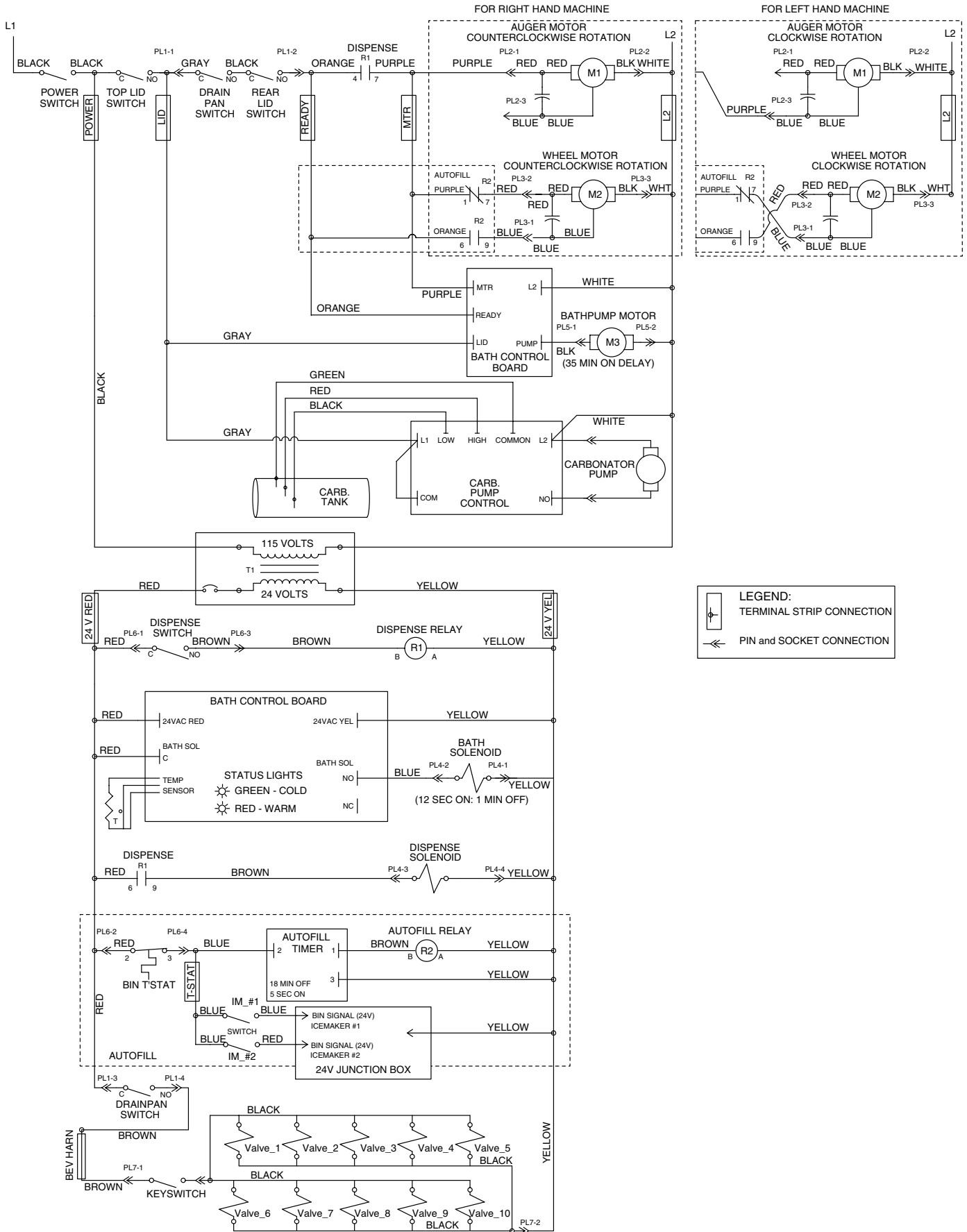
**auger motor**  
Side View



**dispenser**  
Front View



# Wiring diagram



## Dispenser troubleshooting guide

### Before calling for service

1. Check that ice is in the dispenser and that congealed cubes are not causing a jam.
2. Check that circuit breaker and switches are in ON position.
3. Check that drain pan, rear lid and top are on securely. If ajar, dispenser will not operate. When the top is off, auger does not operate, even though the solenoids do (page 17).
4. Check that all drains are clear.

**Note: For units equipped with Follett compressed nugget icemaker, see Icemaker Operation and Service Manual for service and troubleshooting information.**

Symptom	Possible cause	Solution
Ice does not dispense. <ul style="list-style-type: none"> <li>• Auger motor does not run</li> <li>• Wheel motor does not run</li> </ul>	<ol style="list-style-type: none"> <li>1. Power switch faulty or in OFF position; loose connection.</li> <li>2. Faulty dispense switch.</li> <li>3. Faulty transformer.</li> <li>4. Drain pan ajar.</li> <li>5. Faulty drain pan safety switch.</li> </ol>	<ol style="list-style-type: none"> <li>1. Turn power switch to ON position; check connections.</li> <li>2. Replace switch.</li> <li>3. Replace transformer.</li> <li>4. Check pan and reseal.</li> <li>5. Replace switch.</li> </ol>
Ice does not dispense. <ul style="list-style-type: none"> <li>• Auger motor runs</li> <li>• Wheel motor runs</li> <li>• Gate does not open</li> </ul>	<ol style="list-style-type: none"> <li>1. Loose electrical connection.</li> <li>2. Linkage problem between solenoid and gate.</li> <li>3. Faulty solenoid.</li> </ol>	<ol style="list-style-type: none"> <li>1. Check connections.</li> <li>2. Check linkage.</li> <li>3. Replace solenoid.</li> </ol>
Ice does not dispense. <ul style="list-style-type: none"> <li>• Auger motor does not run</li> <li>• Wheel motor runs</li> </ul>	<ol style="list-style-type: none"> <li>1. Loose electrical connection.</li> <li>2. Faulty auger motor.</li> <li>3. Faulty run capacitor.</li> </ol>	<ol style="list-style-type: none"> <li>1. Check connections.</li> <li>2. Check auger motor.</li> <li>3. Check run capacitor.</li> </ol>
Ice does not dispense. <ul style="list-style-type: none"> <li>• Auger motor runs</li> <li>• Wheel motor does not run</li> </ul>	<ol style="list-style-type: none"> <li>1. Loose electrical connection.</li> <li>2. Faulty wheel motor.</li> <li>3. Faulty run capacitor.</li> </ol>	<ol style="list-style-type: none"> <li>1. Check connections.</li> <li>2. Check wheel motor.</li> <li>3. Check capacitor.</li> </ol>
Warm drinks or soda foaming.	<ol style="list-style-type: none"> <li>1. No ice in storage bin.</li> <li>2. Water drained out of ice water bath.</li> <li>3. Circulating pump not running.</li> <li>4. CO<sub>2</sub> pressure is set too high.</li> </ol>	<ol style="list-style-type: none"> <li>1. Fill storage area with ice or check icemaker operation.</li> <li>2. Check that ice water bath drain tube is in fixed upright position.</li> <li>3. Check pump and PC board for output.</li> <li>4. Set CO<sub>2</sub> pressure to 75 psi.</li> </ol>
No ice in dispenser.	<ol style="list-style-type: none"> <li>1. Power switch in OFF position or faulty.</li> <li>2. Bin signal switches in OFF position or faulty.</li> <li>3. Faulty bin thermostat.</li> <li>4. Faulty transformer.</li> <li>5. Icemaker related problem.</li> <li>6. Faulty or disconnected wiring.</li> </ol>	<ol style="list-style-type: none"> <li>1. Check switch and replace if necessary.</li> <li>2. Check switch and replace if necessary.</li> <li>3. Replace bin thermostat.</li> <li>4. Replace transformer.</li> <li>5. Refer to Icemaker Operation and Service Manual for diagnosing.</li> <li>6. Check for power and bin signal on icemaker PC board.</li> </ol>

Symptom	Possible cause	Solution
Carbonator pump not turning on.	<ol style="list-style-type: none"> <li>1. Loose connection.</li> <li>2. Electrode connections on carbonator tank are satisfied.</li> <li>3. Carbonator pump or level control board is defective.</li> </ol>	<ol style="list-style-type: none"> <li>1. Check carbonator pump power at plug and at level control board.</li> <li>2a. Check connection between low level electrode and level control board.</li> <li>2b. Check ground wire on carbonator tank.</li> <li>3. Replace pump/control board.</li> </ol>
Carbonator pump is not turning off.	<ol style="list-style-type: none"> <li>1. Loose connection.</li> </ol>	<ol style="list-style-type: none"> <li>1a. Check connection between high level electrode and level control board.</li> <li>1b. Replace electrodes/control board.</li> </ol>
Carbonation system is not carbonating.	<ol style="list-style-type: none"> <li>1. Loose connection.</li> <li>2. CO<sub>2</sub> pressure.</li> <li>3. Water pressure is too high.</li> <li>4. Carbonator pump is defective.</li> </ol>	<ol style="list-style-type: none"> <li>1. Check all CO<sub>2</sub> and water connections.</li> <li>2. Set CO<sub>2</sub> pressure to 75 psi.</li> <li>3. Lower water pressure to approximately 50 psi.</li> <li>4. Replace pump.</li> </ol>
Carbonation system is producing excessively carbonated beverages.	<ol style="list-style-type: none"> <li>1. CO<sub>2</sub> pressure is set too high.</li> <li>2. Drinks may be warm.</li> </ol>	<ol style="list-style-type: none"> <li>1. Set CO<sub>2</sub> pressure to 75 psi.</li> <li>2. See “warm drinks” symptom.</li> </ol>

**If problems persist after following this basic troubleshooting guide, call Follett’s technical service department at (800) 523-9361 or (888) 2-FOLLETT or (610) 252-7301.**

## Operational Status

The chart below shows the operational status of various parts when certain switches are turned off or accessories are removed.

Condition	Pump	Solenoids	Auger	Wheel	Beverage valves
Top lid off	OFF	ON	OFF	OFF	ON
Rear lid off	ON	ON	OFF	OFF	ON
Drain pan off	ON	ON	OFF	OFF	OFF
On/OFF switch in off position	OFF	OFF	OFF	OFF	OFF
Beverage switch in OFF position	ON	ON	ON	ON	OFF

## Water bath circuit board operation

The temperature sensor is hard wired directly to the circuit board. The waterbath circuit board operates on 24 volts AC. The bath pump will run for 35 minutes whenever ice is dispensed or the bath calls for ice.

Optimal beverage temperature is controlled by the circuit board located in the electrical box. The board monitors the waterbath temperature and holds it to a factory setting. When the Red LED is ON, the bath solenoid, auger motor, wheel motor and bath pump are energized. Ice will be dispensed into the waterbath for 12 seconds, then stop for 60 seconds. The pump will stay energized, and the circuit board will then monitor the water temperature. If it is below the set point, the Green LED will come on, the Red LED light will go off, and ice will not dispense into the waterbath. If the temperature of the bath is determined to be above the set point, the Red LED will remain on. The circuit board has a delay of 60 seconds before more ice is dispensed into the waterbath.

### LED indicators:

Green – the waterbath is at the set temperature.

Red – the bath temperature is above the set temperature and the bath is calling for ice.

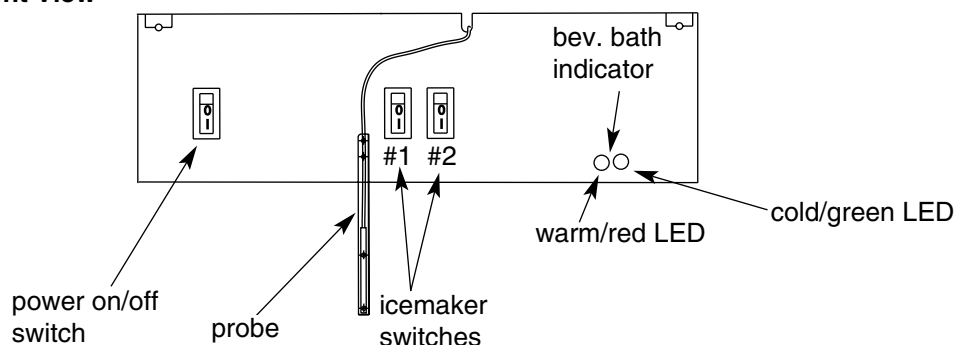
### Flashing LED indicators:

Flashing Red and Green – the circuit board has gone into an **error mode**:

**Alternate flashing** – circuit board has power and is waiting for hopper cover and dispenser top to be replaced.

**Simultaneous flashing** – the waterbath did not reach set temperature in 40 minutes. Reset this error mode by turning power off, removing top lid, drain pan or rear lid.

## Electrical box Front View

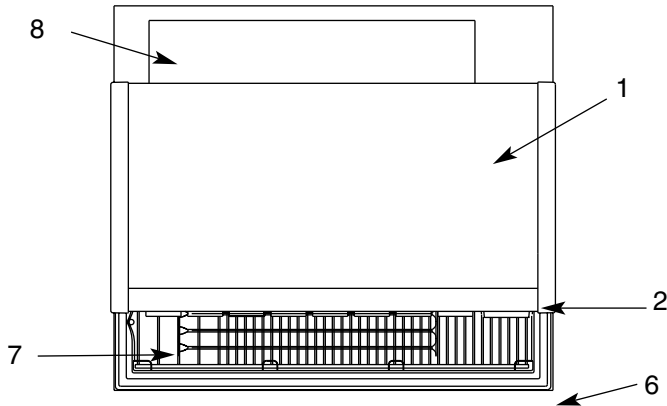




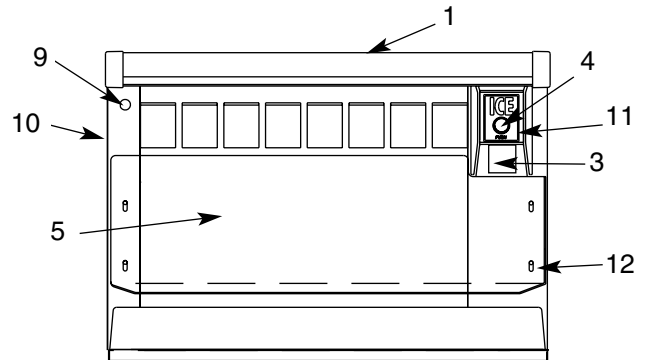
# Replacement parts

## Dispenser exterior

**Top View**  
8 valve unit with right hand (RH) tower

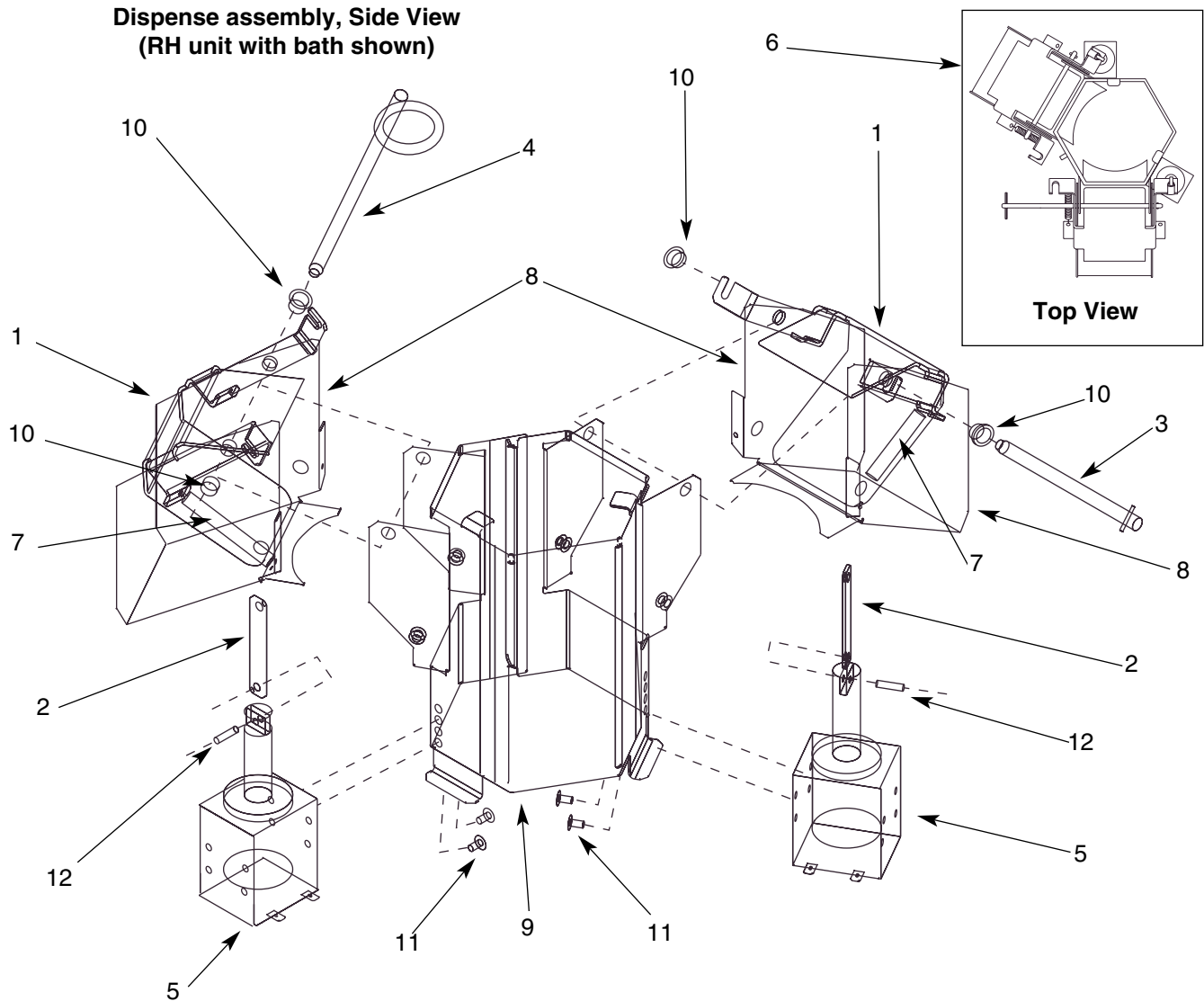


**Front View**  
8 valve unit with right hand (RH) tower  
(push-button dispensing)



Reference #	Description	Part #
1	Lid, 8 valve unit (includes "Follett" label)	502436
1	Lid, 10 valve unit (includes "Follett" label)	502437
2	Label, "Follett"	502438
3	Cover, dispense chute, lever operation	502439
3	Cover, dispense chute, push-button operation (includes button)	502440
4	Switch, push-button operation	502441
5	Backsplash, RH unit, 8 valves	502445
Not shown	Backsplash, LH unit, 8 valves	502444
Not shown	Backsplash, RH unit, 10 valves	502443
Not shown	Backsplash, LH unit, 10 valves	502442
6	Drain pan, 8 valve unit	502446
Not shown	Drain pan, 10 valve unit	502447
7	Grille, drain pan, 8 valve unit	502450
Not shown	Grille, drain pan, 10 valve unit	502451
8	Cover, ice storage bin, rear — all U155 units (except N units)	502452
Not shown	Cover, ice storage (under drain pan) — all U155 units	502453
9	Switch, key lock for valves	501409
Not shown	Key, beverage lock switch	501286
10	Panel, end, beverage, RH unit	502584
Not shown	Panel, end, beverage, LH unit	502583
Not shown	Panel, access, RH and LH units	502585
Not shown	Panel, rear, motor support, RH unit	502586
Not shown	Panel, rear, motor support, LH unit	502587
Not shown	Panel, front, dispense mechanism, RH unit	502588
Not shown	Panel, front, dispense mechanism, LH unit	502589
Not shown	Panel, rear, 8 valve	502590
Not shown	Panel, rear, 10 valve	502591
11	Label, ice, dispense cover, push-button	502623
Not shown	Label, ice, dispense cover, lever	502622
Not shown	Clip, Tinnerman, 10-32	502621
12	Thumbscrew, backsplash, 10-32 x 1/2	501100
Not shown	Legs, 6" (153mm) adjustable to 9" (229mm) — set of 4	502454
Not shown	Screw, 10-32 x 1/2	502287
Not shown	Plug 2 lead, male	502333
Not shown	Plug 2 lead, female	502334

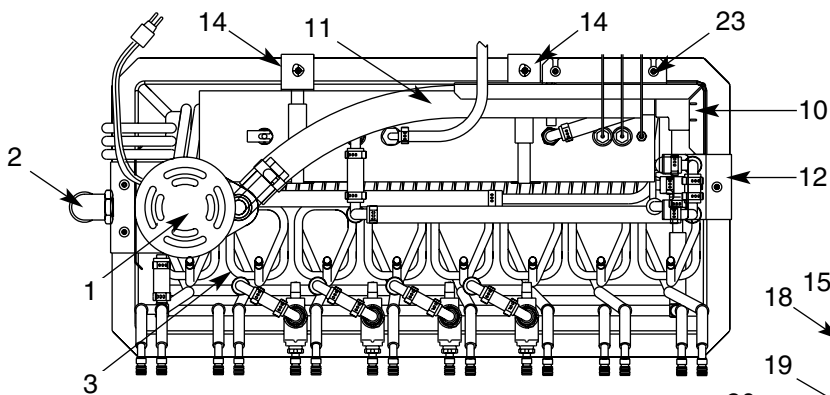
# Dispense assembly



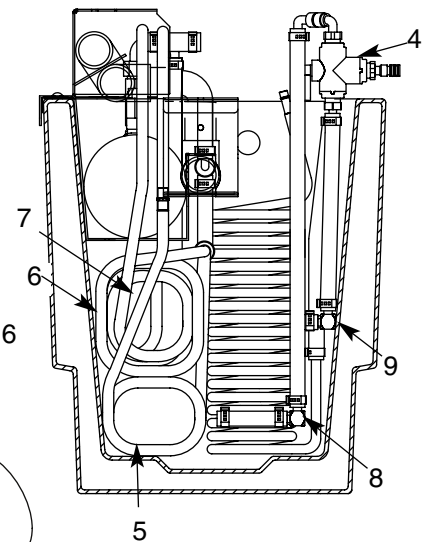
Reference #	Description	Part #
1	Gate, dispense	502455
2	Linkage pin, gate/solenoid	502456
3	Pin, quick release, 3" (77mm), bath gate and lever	501949
4	Pin, quick release, 5.53" (141mm), dispense gate	502102
5	Solenoid (includes linkage pin)	00126607
6	Dispense mechanism assembly, bath, RH unit	502448
Not shown	Dispense mechanism assembly, bath, LH unit	502449
Not shown	Dispense mechanism assembly, non-bath RH unit	502458
Not shown	Dispense mechanism assembly, non-bath, LH unit	502496
7	Spring, dispense mechanism (1 per side)	501950
8	Chute, ice	502457
9	Wrap, dispense mechanism	502607
10	Bushing, Ni liners	501249
11	Screw, 8-32 x 5/16	502625
12	Pin, spring	502624
Not shown	Push pins, clear chute	502618
Not shown	Chute, focus — clear plastic	502459
Not shown	Lever, dispense	501953

## Waterbath

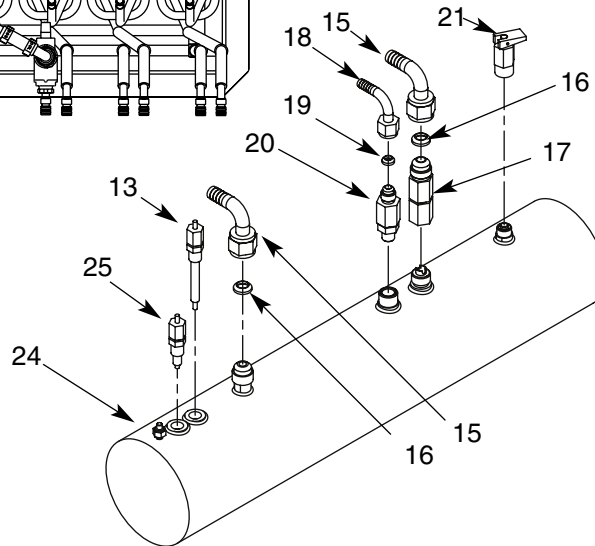
### Top View



### Side View

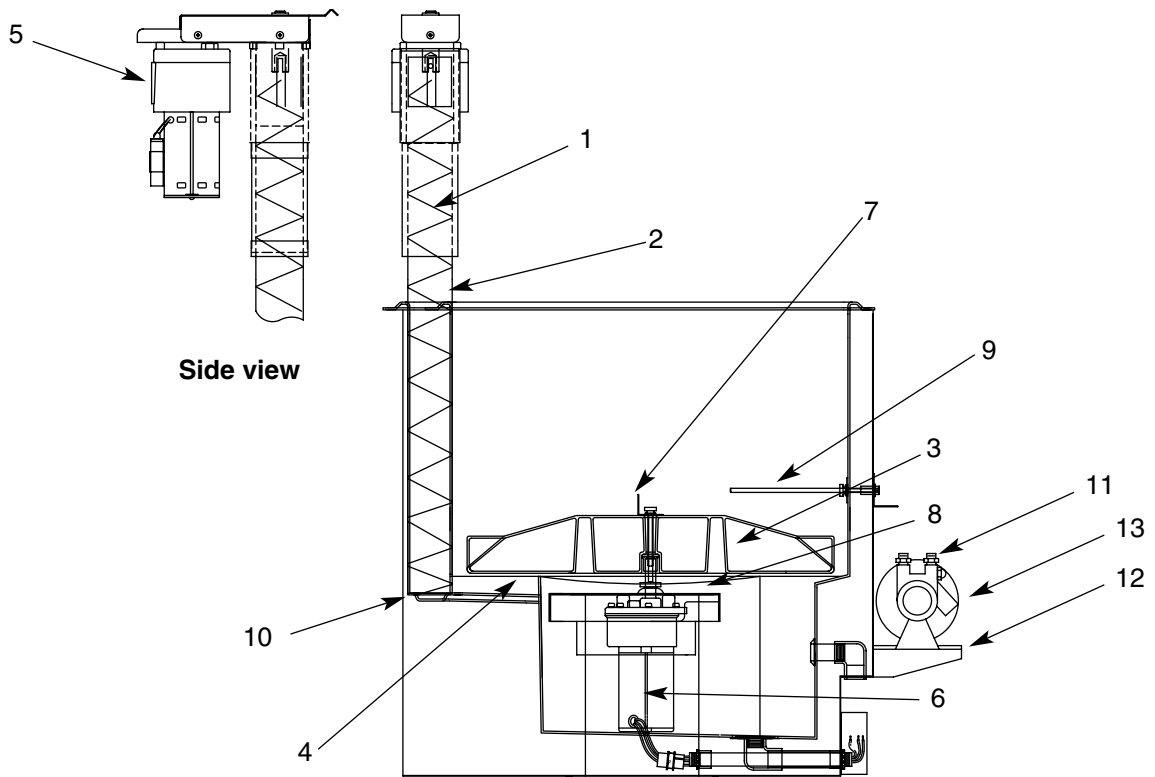


## Carbonator tank – Side View



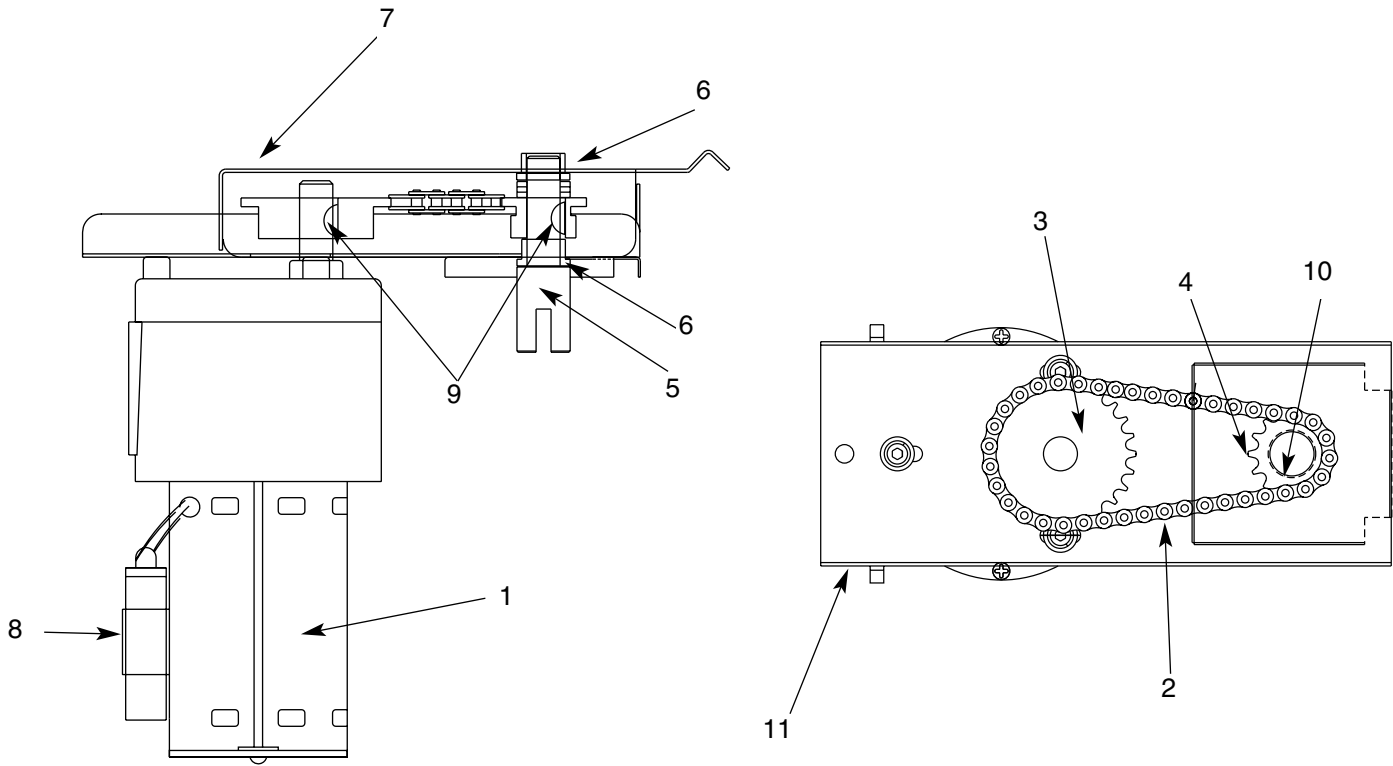
Reference #	Description	Part #
1	Pump, water bath (includes mounting plate and elbow)	00111476
2	Elbow, overflow drain, 1" (26mm) x 3/4 MPT	502465
Not shown	Elbow, clean-out drain, 3/8" (10mm) x 3/8 MPT	502466
3	Coil, syrup	00125864
4	Valve, QuickCARB assembly	00126979
5	Coil, carbonated water, 8 valve	00119792
Not shown	Coil, carbonated water, 10 valve	00119560
6	Coil, carbonated, outer, 8 valve	00119867
Not shown	Coil, carbonated, outer, 10 valve	00119560
7	Coil, water, non-carb, inner, 8 valve	00119875
Not shown	Coil, water, non-carb, inner, 10 valve	00125435
8	Manifold, carbonated water, 8 valve	00207539
Not shown	Manifold, carbonated water, 10 valve	00207540
9	Manifold, water, 8 valve	00123331
Not shown	Manifold, water, 10 valve	00123141
10	Shield, splash, RH	00125435
Not shown	Shield, splash, LH	00125393
11	Pump, discharge assembly, LH, 8 valve	00127001
Not shown	Pump, discharge assembly, RH, 8 valve	00127019
Not shown	Pump, discharge assembly, LH, 10 valve	00127027
Not shown	Pump, discharge assembly, RH, 10 valve	00127035
12	Bracket, mounting outlet	00111633
13	Water probe, low level (black)	00107417
14	Bracket, carbonation tank	00106625
15	Elbow, 3/8" swivel (includes 00107433, 00107490)	00107425
16	Washer, seal, 3/8" (black)	00107433
17	Check valve, 3/8" (includes 00107433)	00107532
18	Elbow, 1/4" swivel (includes 00107466, 00106914)	00107458
19	Washer, seal, 1/4" (white)	00107466
20	Check valve, 1/4" (includes 00107466)	00107540
21	Pressure relief valve	00107482
22	Bracket, pump hose (includes 506627)	00111351
23	Screw, 8 x 1/2, stainless	502627
24	Carbonator tank	00107508
25	Water probe, high level (red)	00107409

# Hopper



Reference #	Description	Part #
1	Auger, LH unit (black, stamped with "1")	502491
Not shown	Auger, RH unit (gray, stamped with "2")	502492
2	Tube, auger, LH unit with beverage bath	502486
Not shown	Tube, auger, RH unit with beverage bath	502485
Not shown	Tube, auger, RH unit without beverage bath	502487
Not shown	Tube, auger, LH unit without beverage bath	502488
3	Wheel, dispense (includes stud and rotating agitator)	501681
4	Baffle (under dispense wheel)	501684
Not shown	Drive bar (under dispense wheel)	501682
5	Motor, vertical auger	502476
6	Motor, wheel	502560
Not shown	Seal, wheel motor	501333
Not shown	Spacer, wheel motor	501768
Not shown	Capacitor, wheel motor	501782
7	Agitator, rotating, 21" (534mm) long	502484
8	Plate, wheel motor mounting	502615
9	Agitator, stationery	502490
10	Plate, auger bearing	501696
Not shown	Bracket, ice tube, double tube	502497
Not shown	Ice transport tube (sold by the foot)	500366
Not shown	Ice transport tube, 10 ft	502522
Not shown	Ice transport tube, 20 ft	502523
Not shown	Insulation, transport tube (sold by the foot)	501176
Not shown	Cover, blank ice entry	502674
Not shown	Thermostat	501432
Not shown	Gasket, ice entry	502673
Not shown	Plate, ice entry, 2 holes	502674
11	Union, 3/8" (includes 00107433)	00107516
12	Shelf, carbonator pump	00106658
13	Pump, carbonator (includes 00106658, 00109355)	00107524
Not shown	Mounting screws & fittings, carbonator pump	00109355

# Auger motor

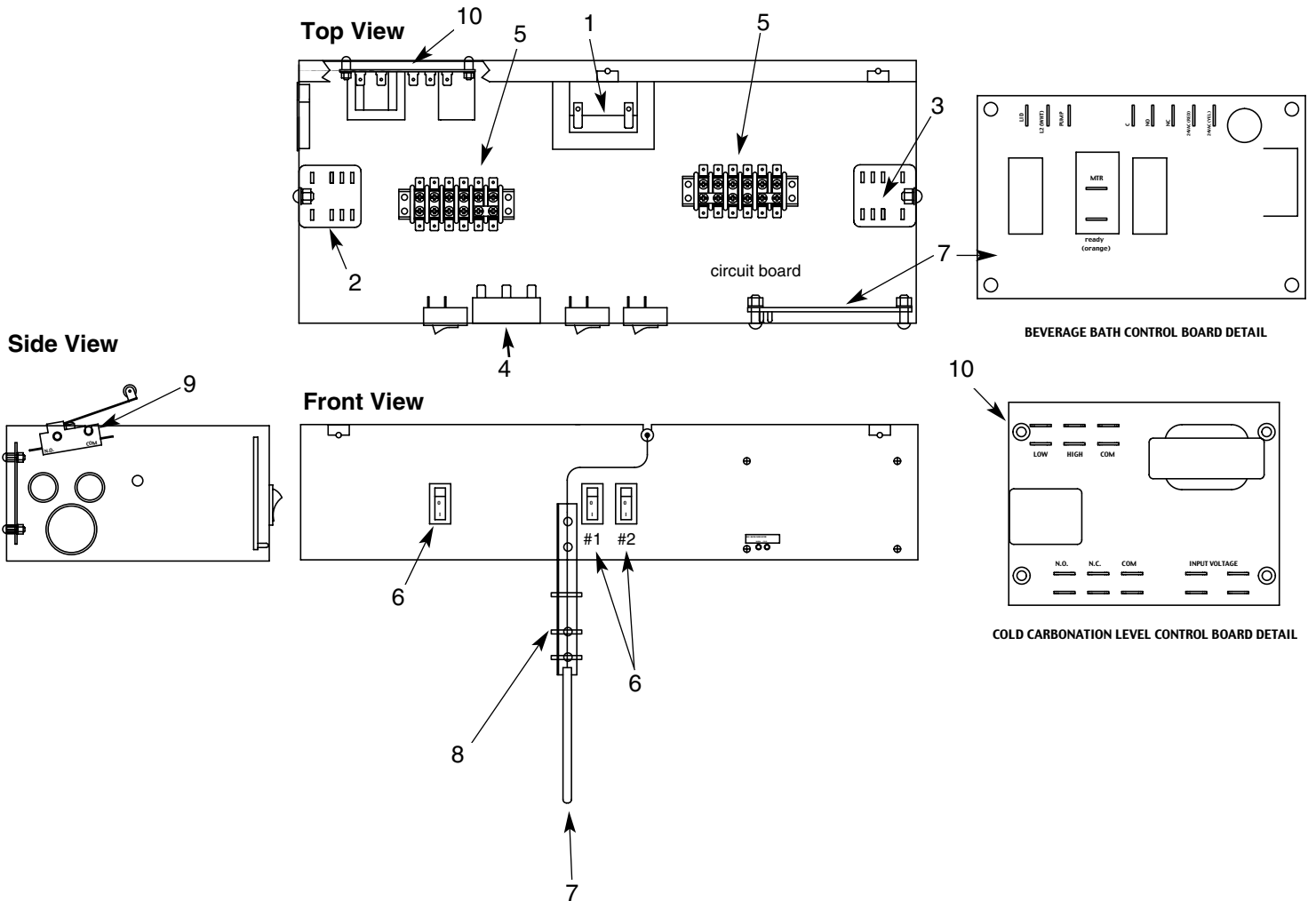


Side View

Top View

Reference #	Description	Part #
	Auger motor/drive assembly, vertical (includes all items below)	502493
1	Motor, vertical auger (includes gearbox and capacitor)	502476
2	Chain, auger drive #35, 40p	502477
3	Sprocket 35#, 22T 5/8 bore	502478
4	Sprocket 35#, 12T 5/8 bore	502479
5	Drive shaft	502480
6	Bearing, auger, upper and lower	501314
7	Cover and bearing, chain drive (includes 501314)	502481
8	Capacitor, 25mf, 270V	501550
9	Key, Woodruff	502482
10	Washers, thrust, (4)	501765
11	Mounting plate, auger motor (includes 501314)	502483

# Electrical components



Reference #	Description	Part #
1	Transformer, 24V	502058
2	Relay, auto fill	501826
3	Relay, dispense	501826
4	Timer, auto fill (automatic fill units)	502471
5	Strips, terminal	502472
6	Switches (power and icemaker)	502209
7	Board, circuit and probe (one unit)	502473
8	Bracket, probe	502474
9	Switch, safety	502511
Not shown	Switch, safety, rear cover assembly, LH unit	502498
Not shown	Switch, safety, rear cover assembly, RH unit	502499
Not shown	Switch, safety, drain pan assembly, LH unit	502500
Not shown	Switch, safety, drain pan assembly, RH unit	502501
Not shown	Switch, dispense, lever	502505
Not shown	Bracket, safety switch, rear	502608
Not shown	Bracket, safety switch, drain pan, RH	502609
Not shown	Bracket, safety switch, drain pan, LH	502610
Not shown	Thermostat, bin level	500514
10	Control board, cold carbonation	00106708



