

Use & Care Guide
Wine Cooler

Guia de Uso y Cuidado
Refrigerador de Vinos

Guide D'utilisation et D'entretien
Refroidisseur à Vin

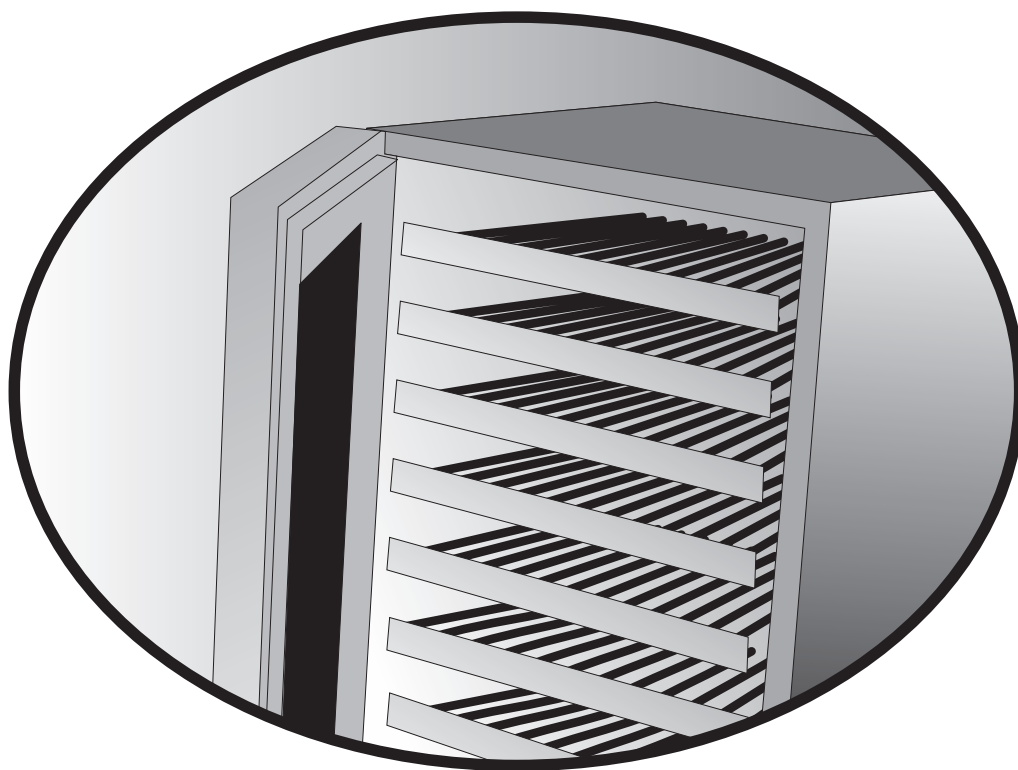

 **Electrolux**

Please Read and Save This Guide

Thank you for choosing Electrolux, the new premium brand in home appliances. This Use & Care Guide is part of our commitment to customer satisfaction and product quality throughout the service life of your new wine cooler.

We view your purchase as the beginning of a relationship. To ensure our ability to continue serving you, please use this page to record key product information.

IMPORTANT

PLEASE READ all instructions completely before attempting to install or operate the unit. All wine coolers require a connection to an electrical power source. Improper hook-up can result in a safety hazard and potential damage to the product or contents! Proper installation, in accordance with the manufacturer's specifications and all local codes, is the sole responsibility of the consumer. The manufacturer is not responsible for any installation expenses or damages incurred due to improper installation. If you are unsure of your ability to safely connect electric power to the unit, consult a licensed and insured professional to perform all electrical work.

Once you have your unit installed, we suggest you keep this manual in a safe place for future reference. Should any problems occur, refer to the "**Troubleshooting**" section of this manual. This information will help you quickly identify a problem and get it remedied. In the event you require assistance, please contact the dealer where you purchased your unit.

Make a Record for Quick Reference

Whenever you call to request information or service, you will need to know your model number and serial number. You can find this information on the serial plate located on the ceiling of your unit and on the product registration card.

Product Registration Card

The package containing this manual also includes your product registration information. Warranty coverage begins at the time your Electrolux wine cooler was purchased.



NOTE

Registering your product with Electrolux enhances our ability to serve you. You can register online (at the Internet address below) or by dropping your Product Registration Card in the mail. Complete and mail the Product Registration Card as soon as possible to validate the registration date.

Please record the purchase date of your Electrolux unit and your dealer's name, address and telephone number.

Purchase Date

Electrolux Model Number

Electrolux Serial Number

Dealer Name

Dealer Address

Dealer Telephone

Keep this manual and the sales receipt together in a safe place for further reference.

Questions?

For toll-free telephone support in the U.S. and Canada:

1-877- 4ELECTROLUX (1-877-435-3287)

For online support and Internet product information:
www.electroluxicon.com

Table of Contents

Finding Information	2
Please Read and Save This Guide	2
Make a Record for Quick Reference	2
Product Registration Card	2
Questions?	2
Safety	4
Important Safety Instructions	4
Safety Precautions	4
Definitions	4
General Precautions	4
Installation	5
Installing the Wine Cooler	5
Site Preparation	7
Leveling	8
Leveling the Unit	8
Door Reversal	9
Reversing the Door	9
Start-Up and Temperature Control	13
Starting the Unit	13
Adjusting the Temperature	13
Operation	14
Description of Features	14
Alarms	14
Sabbath Mode	14
Storage	15
Proper Storage	15
Stocking Recommendations	15
Maintenance	16
Maintaining Your Wine Cooler	16
Exterior Cleaning for Your Stainless Steel Model	16
Interior Cleaning	16
Wine Rack Removal/Installation	16
Troubleshooting	17
Before You Call for Service	17
If Service is Required	17
Warranty Information	18

Important Safety Instructions

Safety Precautions

Do not attempt to install or operate your unit until you have read the safety precautions in this manual. Safety items throughout this manual are labeled with a Danger, Warning or Caution based on the risk type.

Definitions

 This is the safety alert symbol. It is used to alert you to potential personal injury hazards. Obey all safety messages that follow this symbol to avoid possible injury or death.

DANGER

DANGER indicates an imminently hazardous situation which, if not avoided, will result in death or serious injury.

WARNING

WARNING indicates a potentially hazardous situation which, if not avoided, could result in death or serious injury.

CAUTION

CAUTION indicates a potentially hazardous situation which, if not avoided, may result in minor or moderate injury.

IMPORTANT

Indicates installation, operation or maintenance information which is important but not hazard-related.

General Precautions

DANGER

RISK OF CHILD ENTRAPMENT. Before you throw away your old appliance, take off the doors and leave shelves in place so that children may not easily climb inside.

WARNING

- Never attempt to repair or perform maintenance on the unit until the electricity has been disconnected.
- Altering, cutting of power cord, removal of power cord, removal of power plug, or direct wiring can cause serious injury, fire and/or loss of property and/or life and will void the warranty.
- Do not lift unit by door handle.

CAUTION

- Use care when moving the unit. Some edges are sharp and may cause personal injury. Wear gloves when moving or repositioning the unit.
- Never install the unit behind closed doors. Be sure front grille is free of obstruction. Obstructing free air flow can cause the unit to malfunction, and may void the warranty.
- Allow unit temperature to stabilize for 24 hours before use.

CAUTION

- Use only genuine Electrolux replacement parts. Imitation parts can damage the unit and may void the warranty.

Installing the Wine Cooler

Your Electrolux wine cooler has been designed for either free-standing or built-in installation. When built-in, your wine cooler does not require additional air space for top, sides or rear. In either case, the front grille must **NOT** be obstructed.

 **NOTE**

To ease unit installation and removal, it is recommended that the cabinet rough opening dimensions be increased by at least 1/4 inch over the dimensions given for your unit.

 **NOTE**

All units require zero clearance when installed flush with a cabinet or wall. Electrolux ICON Designer stainless steel models require a minimum 2 1/16 inch handle clearance when installed against a wall or cabinet that extends beyond the front edge of the unit.

ICON Designer Unit Dimensions

Width	Height	Depth
23 13/16 inch	34-35 inches	25 7/8 inch

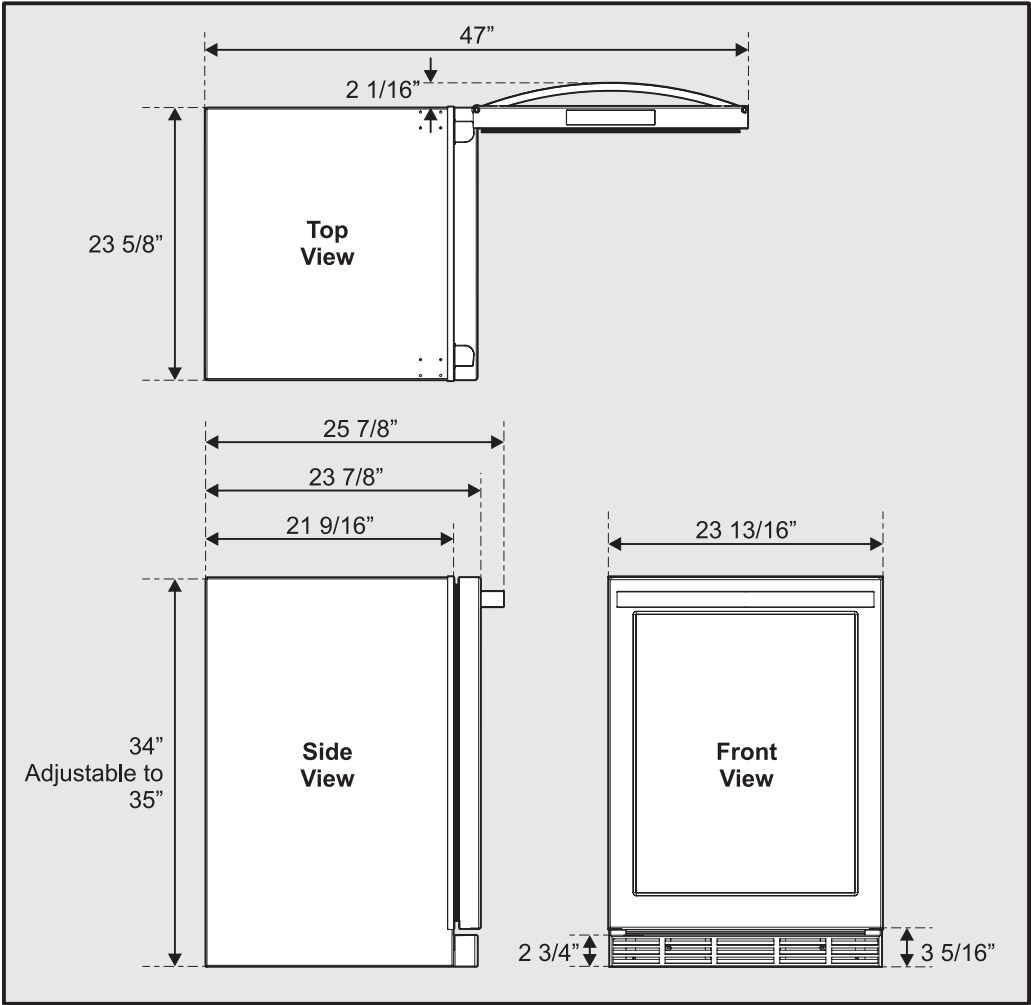

ICON Designer Product Dimensions

6

Installation

NOTE

All units require zero clearance when installed flush with a cabinet or wall. Electrolux ICON Pro stainless steel models require a minimum 2 11/16 inch handle clearance when installed against a wall or cabinet that extends beyond the front edge of the unit.

ICON Pro Unit Dimensions

Width	Height	Depth
23 13/16 inch	34-35 inches	26 1/5 inch

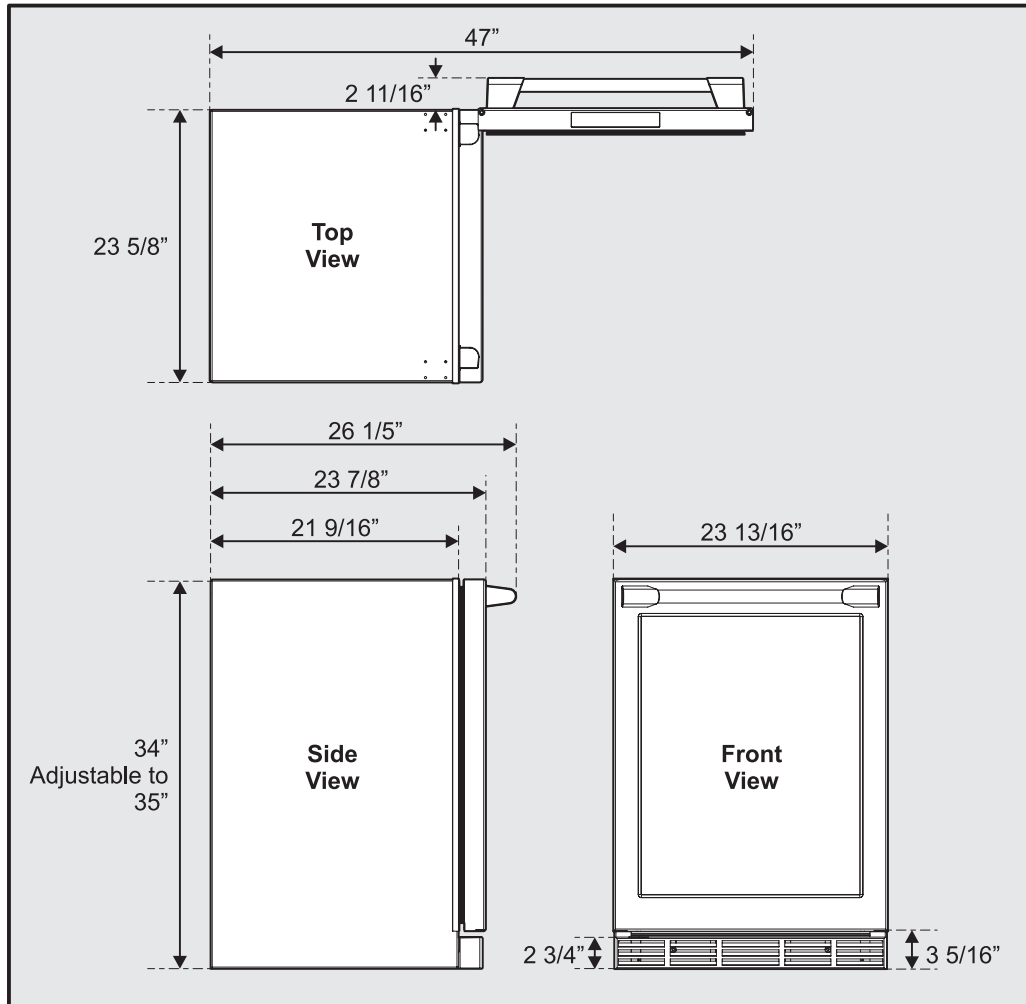

ICON Pro Product Dimensions

Site Preparation

- 1 Position the unit on a flat, level surface capable of supporting the entire weight of the unit. Remember the unit will be significantly heavier once it is fully loaded.
- 2 This unit requires a grounded and polarized 115 VAC, 60Hz, 15A circuit (normal household current).
- 3 Avoid connecting the unit to a Ground Fault Interruptor (GFI). GFIs are prone to nuisance tripping which will cause the unit to shut down. GFIs are generally not used on circuits which power equipment that must run unattended for long periods of time.
- 4 The unit must be installed according to your local codes and ordinances.

- 6 Wipe out inside of unit with a damp cloth.
- 7 Be sure to install the Anti-Tip bracket. Follow the instructions provided with the Anti-Tip bracket kit.

WARNING

The Anti-Tip Kit must be installed on this unit before it is used. Double stacking units may cause serious personal injury.

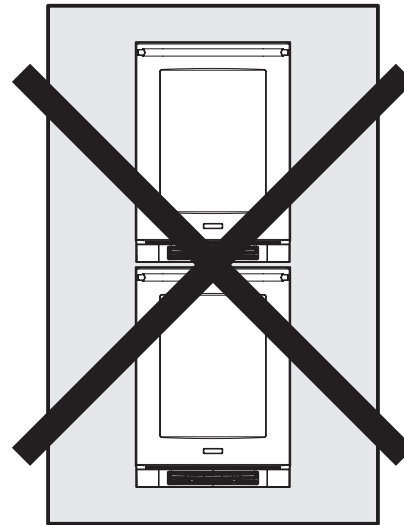

WARNING

ELECTROCUTION HAZARD!

Electrical Grounding Required. This appliance is equipped with a three prong (grounding) polarized plug for your protection against possible shock hazards.

- NEVER remove the round grounding prong from the plug.
- NEVER use a two-prong grounding adapter.
- NEVER use an extension cord to connect power to the unit.

Where a two-prong wall receptacle is encountered or a longer power cord is required, contact a qualified electrician to have it replaced in accordance with applicable electrical codes.

- 5 Position the unit to allow free air flow through the front grille.

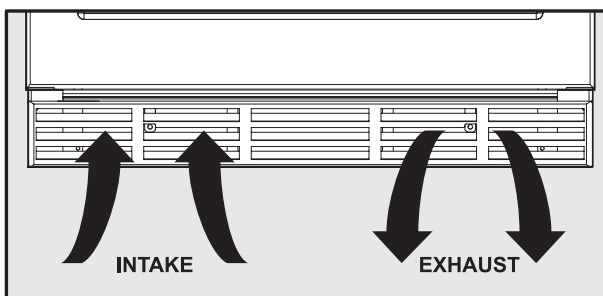

8

Leveling

Leveling the Unit

Position the unit on a flat, level surface capable of supporting the entire weight of the unit when full.

This unit contains four (4) adjustable leveling legs. Turn the legs clockwise to raise and counterclockwise to lower.

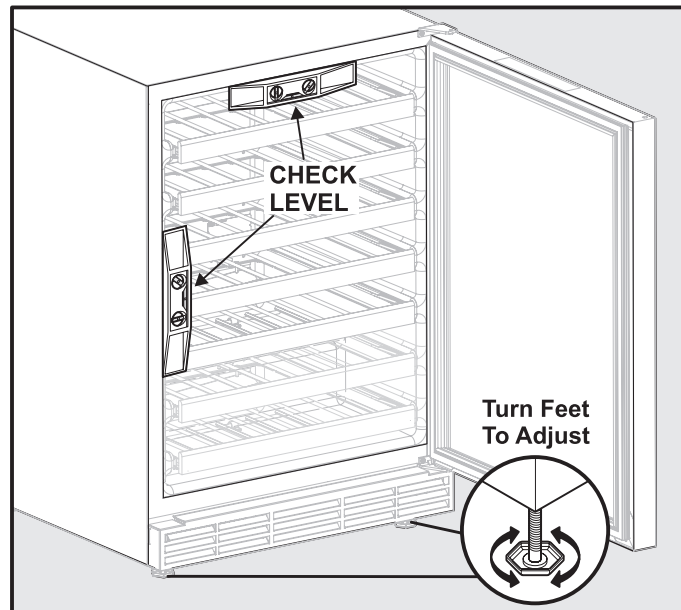

Reversing the Door

This model comes equipped with a RH-swing door. To convert the unit to a LH-swing door (as shown in the Use & Care Guide), certain components must be obtained before beginning the conversion. These components are available from your local dealer or by calling Electrolux.

Order Part Number: 5303418377

To reverse the door:

- 1 Disconnect power to the wine cooler.
- 2 Remove toe grille by removing two (2) screws.

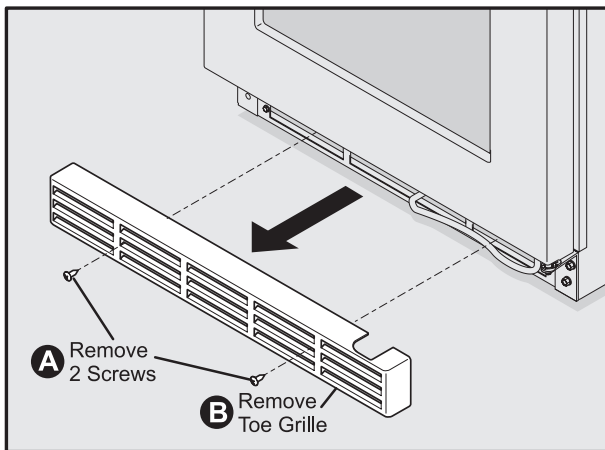

- 3 Disconnect door harness from connector bracket behind lower front panel. Pull harness from behind lower front panel so it is hanging below the door.

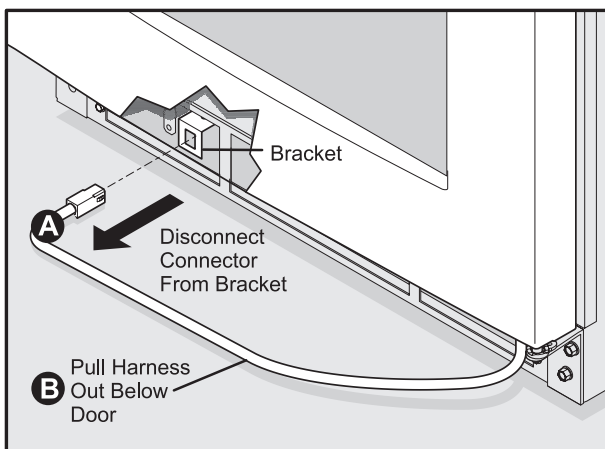

- 4 Remove upper right-hand (RH) hinge bracket by loosening four (4) screws. Be careful to support the door while loosening and removing the upper hinge bracket.

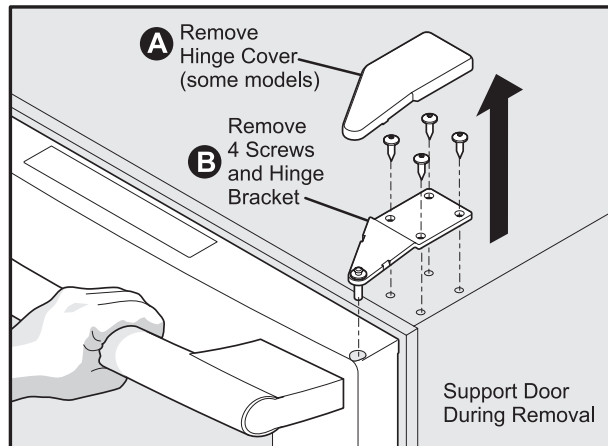

- 5 Lift the door off of the lower RH hinge bracket. Turn the door upside down and place on a soft, non-abrasive surface.

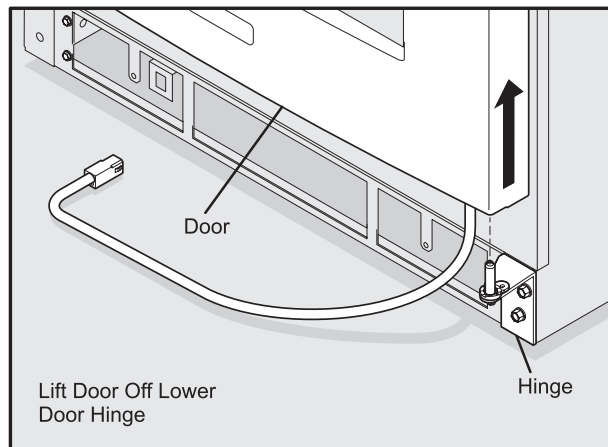

Door Reversal

- 6 Remove access cover by removing two (2) screws.
- 7 Shift door harness from one side to the other. Replace access cover.

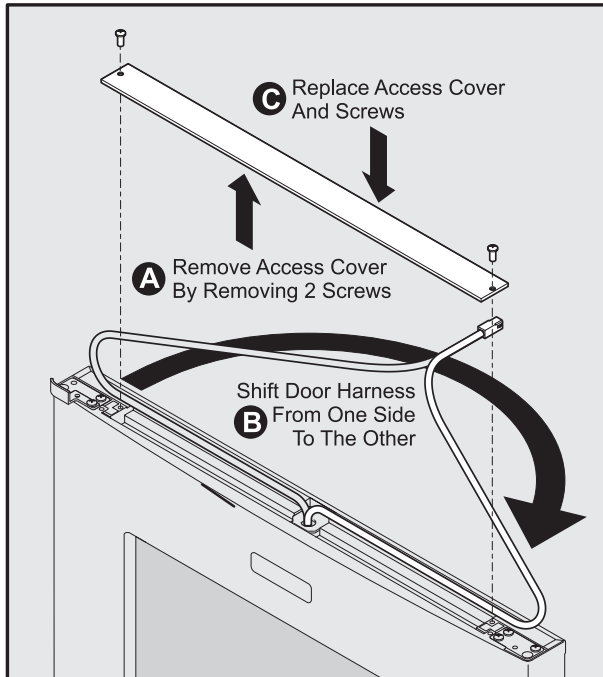

- 8 Remove plastic RH door closer by removing screw. Remove metal RH door stop by removing screw.

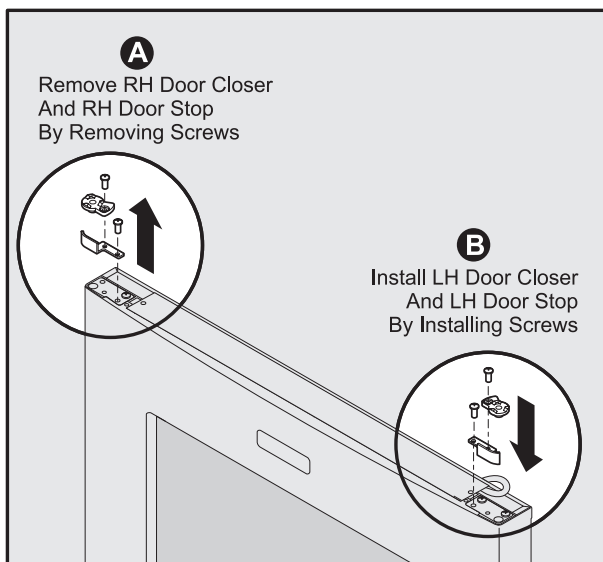

- 9 Install metal left-hand (LH) door stop by installing screw.
- 10 Install plastic LH door stop by installing screw.
- 11 Remove lower RH door hinge by removing two (2) screws. Remove P-clamp and install in LH side.

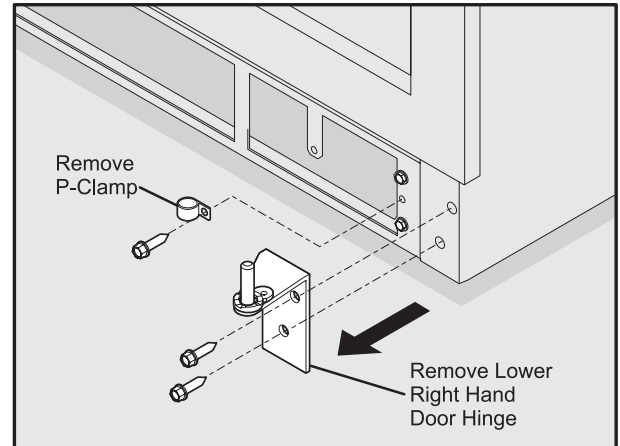

- 12 Install lower LH door closer in lower LH door hinge by installing screw.
- 13 Install lower LH door hinge by installing two (2) screws. Apply petroleum jelly to lower LH hinge pin.

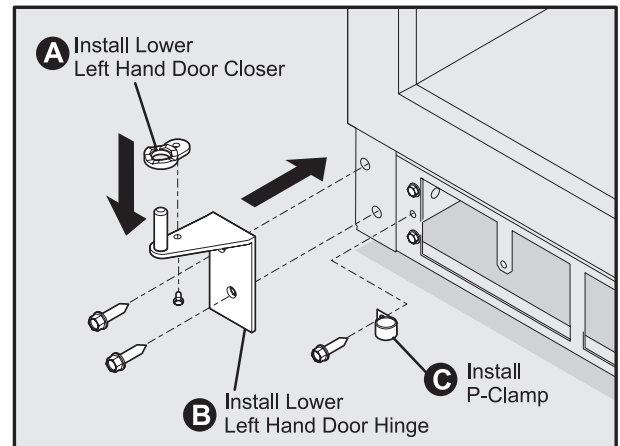

- 14** Remove button plug from upper left side of door and place in upper right side of door. Place door on lower LH hinge bracket.

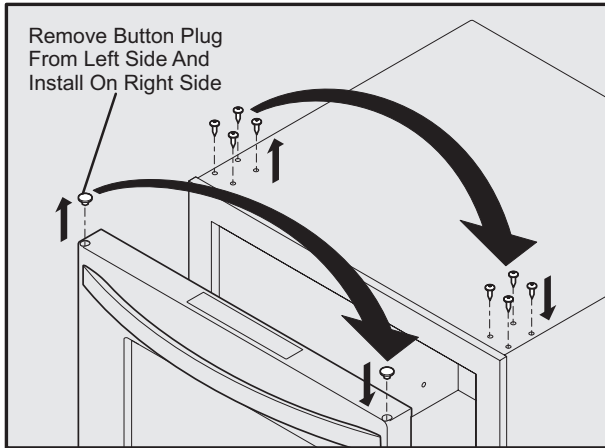

ICON Designer

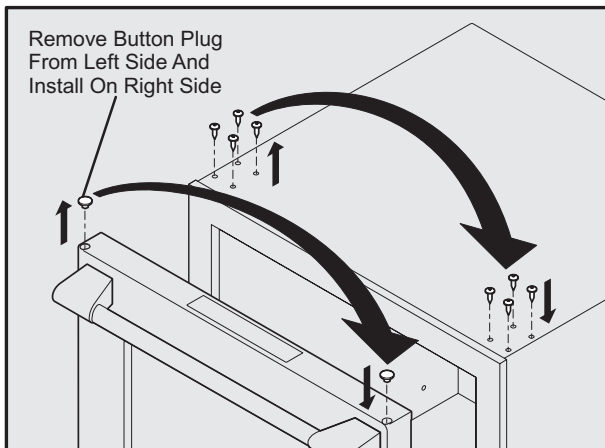

ICON Pro

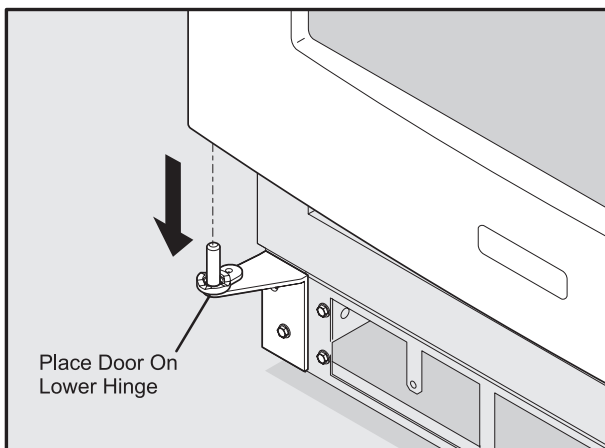

- 15** Install upper LH hinge bracket by installing four (4) screws.

If door does not close properly after reversing, the following actions may be taken:

- Loosen lower hinge screws and align door. Retighten screws.
- Loosen upper hinge screws and align door. Retighten screws.
- Remove door gasket, turn 180°, and reinstall.

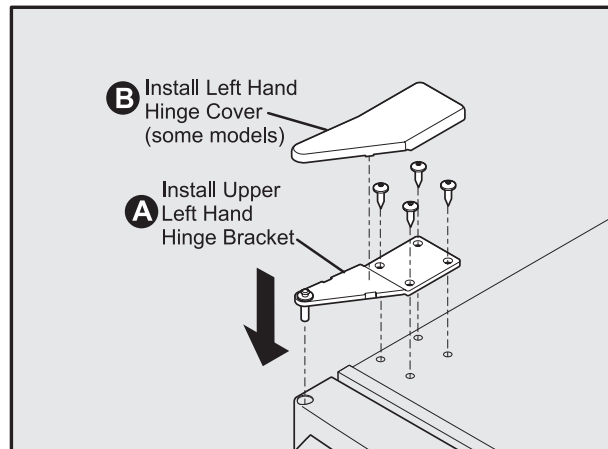

- 16** Route door harness behind lower front panel. Reconnect door harness to bracket.

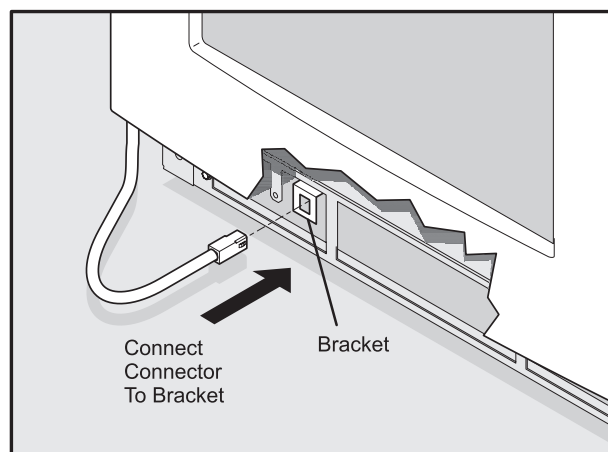

- 17 Reattach toe grille by installing two (2) screws.

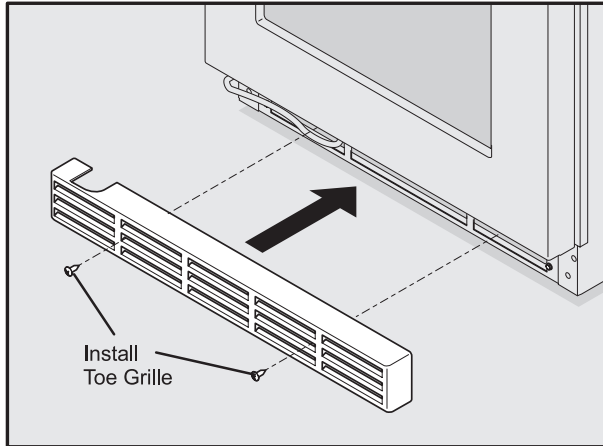

- 18 Reapply power.

Starting the Unit

Your wine cooler is shipped in the ON position; however, you may turn it ON or OFF by pressing and holding the ON/OFF for three (3) seconds and then releasing the key.

Adjusting the Temperature

To accurately check the temperature, insert a reliable thermometer into a plastic (non-breakable) bottle, partially filled with water. Tighten the bottle cap securely.

Place the bottle in the desired area for 24 hours. Refrain from opening the unit during the testing period. After 24 hours, check the temperature of the water.

Press and release the (+) or (-) indicator to adjust the temperature to the desired setting. The temperature display will begin to blink with the first touch and release. Adjust the temperature by touching and releasing the key. After three (3) seconds of inactivity, the display will beep to accept the new temperature.

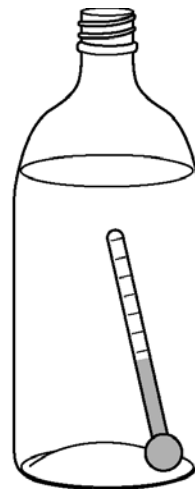

Factors that affect the internal temperatures of the cabinet include:

- 1 Temperature setting.
- 2 Room temperature where installed.
- 3 Number of times the door is opened and closed.
- 4 Amount of time the internal light is illuminated. This affects primarily wines/beverages on the top racks/shelves.
- 5 Installation in direct sunlight or near a heat source.

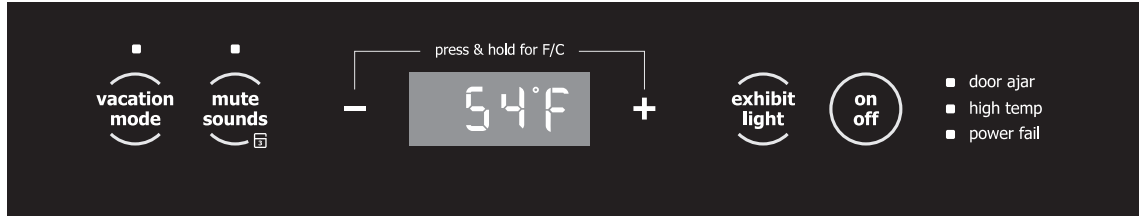

Description of Features

- vacation mode** Conserves energy by disabling interior lights and keypad inputs.
- mute sounds** Tones emitted by each keypress can be turned off based on user preference. The sounds are muted when the red indicator is lit. The **mute sounds** key also is used to acknowledge alarm conditions, denoted by a flashing red indicator. Press and hold the **mute sounds** key for three (3) seconds to enable **control lock**, which prevents undesired changes to the unit settings. Temperature display will show “LOC”.
- temperature mode** Simultaneously press and hold the (+) and (-) keys for three (3) seconds then releasing the key causes the temperature display to toggle from Fahrenheit to Celsius and back again.
- display light** Manually activates the lights, regardless of whether the door is closed. Each successive keypress will advance the interior lights from “Off” to “Low Intensity” to “Maximum Intensity” then to “Off” again. Interior lighting is automatically disabled after 120 minutes, at which point the lights may be manually activated again if desired.
- on off** Press and hold for three (3) seconds then release the key. This allows the user to turn off the cooling system. The temperature display will display “OFF”. **THIS DOES NOT REMOVE POWER FROM THE UNIT.**

Sabbath Mode

Sabbath mode disables portions of the unit and its controls in accordance with the weekly Sabbath and religious holidays observed within the Orthodox Jewish community.



Sabbath mode is enabled and disabled by pressing and holding the **vacation mode** key for five (5) seconds. Temperature display shows “Sb” while in Sabbath mode.

The customer may open or close the door at any time without concern of directly turning on or off any lights, digital readouts, solenoids, fans, valves, compressor, icons, tones or alarms. After power failure, the unit will immediately return to Sabbath mode.

While in Sabbath mode, alarm indicators will not illuminate, nor be accompanied by audible alarms.

For further assistance, guidelines for proper usage and a complete list of models with the Sabbath feature, please visit the web at <http://www.star-k.org>.

Alarms

- door ajar** If the door has been left open for five (5) minutes, an audible alarm will sound and the **door ajar** indicator will illuminate on the right side of the display. The **mute sounds** indicator will blink. Pressing the **mute sounds** key or closing the door will acknowledge the alarm and disable the audible portion and the LED indicator until the door is left open another five (5) minutes.
- power fail** In the event of a power failure or initial power-up, an audible alarm will sound and the **power fail** indicator on the right side of the display will blink. The **mute sounds** indicator will blink. Pressing the **mute sounds** key will acknowledge the alarm and disable the audible portion. All other functions are disabled until the alarm is acknowledged, at which point the **power fail** indicator is turned off and the unit will resume normal operation.

Proper Storage

The wine cooler will accommodate 48 bottles (750 ml size). There are five (5) upper racks that will hold eight (8) bottles each and two lower racks that will hold four (4) bottles each. Specially designed wine racks allow for proper horizontal storage of the wine. The cork remains moist which keeps air from entering the bottle.

Stocking Recommendations

The wine racks allow for the proper horizontal storage of wine. The bottles are properly positioned so that the wine remains in contact with the cork to assure that the cork does not become dry. Use the procedure listed below to stock your wine cooler. White and sparkling wines should be maintained on the bottom to middle racks and red wine on the top racks.

Your wine cooler should be stocked beginning with the bottom rack at the back and working forward staggering the bottles.

Subsequent racks should be stocked similarly, starting with the back of each rack.

Maintaining Your Wine Cooler

Periodic cleaning and proper maintenance will ensure efficiency, top performance, and long life. The maintenance intervals listed are based on normal conditions. You may want to shorten the intervals if you have pets or other special considerations.

Exterior Cleaning for Your Stainless Steel Model

- Your stainless steel model may discolor when exposed to chlorine gas, pool chemicals, salt water, or cleaners with bleach.
- Keep your stainless unit looking new by cleaning with a high quality, all-in-one stainless steel cleaner/polish on a monthly basis. Frequent cleaning will remove surface contamination that could lead to rust. Some installations will require cleaning on a weekly basis.
- DO NOT CLEAN WITH STEEL WOOL PADS.
- DO NOT USE CLEANERS THAT ARE NOT SPECIFICALLY INTENDED FOR STAINLESS STEEL (this includes glass, tile and counter cleansers).
- If any surface discolors or rusting appears, clean it quickly with Bon-Ami or Barkeepers Friend Cleanser and a non-abrasive cloth. Always clean in the direction of the grain. Always finish this process with a high quality, all-in-one stainless steel cleaner/polish to prevent further problems.
- USE OF ABRASIVE PADS SUCH AS SCOTCHBRITE WILL CAUSE THE GRAINING IN THE STAINLESS TO BECOME BLURRED.
- Rust that is allowed to linger can penetrate into the surface of the stainless steel and become impossible to remove.

CAUTION

- **Stainless steel models exposed to chlorine gas and moisture such as areas with spas or swimming pools, may have some discoloration of the stainless steel. Discoloration from chlorine gas is normal. Follow exterior cleaning instructions.**
- **NEVER USE CHLORIDE OR CLEANERS CONTAINING BLEACH TO CLEAN STAINLESS STEEL.**

Interior Cleaning - as Required

- 1 Disconnect power to the wine cooler.
- 2 Remove racks if desired, see “**WINE RACK REMOVAL/INSTALLATION**” below.
- 3 Wipe down the interior with a solution of non-abrasive mild detergent and warm water.
- 4 Rinse with clear water.
- 5 Reconnect power to the unit.

Wine Rack Removal/Installation

- 1 Open door fully.
- 2 Extend wine rack fully.
- 3 Ball bearing slide features plastic release latches on each side. Push release latches, then pull wine rack out.
- 4 To reinstall, push ball bearing slides in fully. Slide rack into ball bearing slide ensuring each side engages properly.

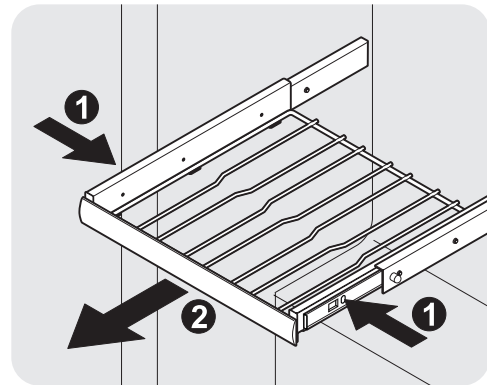

Air Filter

Static Air Filter found in literature pack. Install in proper housing.

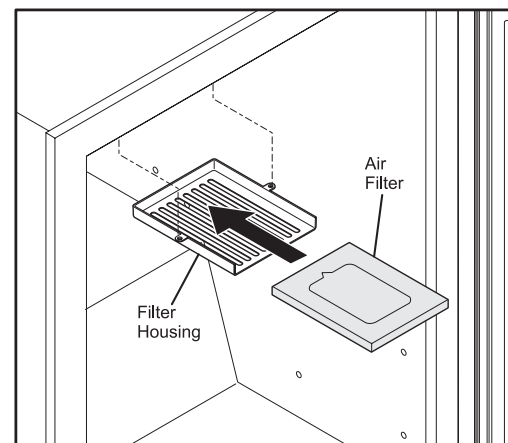

Before You Call for Service

If the unit appears to be malfunctioning, read through this manual first. If the problem persists, check the **Troubleshooting Guide** below. Locate the problem in the guide and refer to the cause and its remedy before calling for service. The problem may be something very simple that can be solved without a service call. Some remedies listed in the **Troubleshooting Guide** are very complex. Consulting or contracting a qualified service technician may be necessary.

If Service is Required

Contact the dealer where you purchased the unit if service is required. State the model and serial number and explain the problem. The model and serial number plate is located on the ceiling of your unit.

If you do not know the name of the selling dealer or a local service company, you can check online at www.electroluxicon.com or call **1-877-435-3287**.



WARNING

ELECTROCUTION HAZARD

NEVER attempt to repair or perform maintenance on the unit until the main electrical power has been disconnected.

Problem	Possible Cause	Remedy
Unit not cold enough. Adjust temperatures (see “ Adjusting the Temperature ” in the “ Start-Up and Temperature Control ” section).	<ul style="list-style-type: none"> Control set too warm. Light staying on. Airflow to front grille blocked. Door gasket not sealing properly. 	<ul style="list-style-type: none"> Adjust temperature colder. Allow 24 hours for temperature to stabilize. Turn off manual light control. See “Operation” Section. Airflow must not be obstructed to front grille. See “Installation” Section. Adjust door gasket.
Unit too cold. Adjust temperatures (see “ Adjusting the Temperature ” in the “ Start-Up and Temperature Control ” section).	<ul style="list-style-type: none"> Control set too cold. 	<ul style="list-style-type: none"> Adjust temperature warmer. Allow 24 hours for temperature to stabilize.
No interior light.	<ul style="list-style-type: none"> Failed LED assembly. 	<ul style="list-style-type: none"> Contact a qualified Electrolux Service Technician.
Light will not go out when door is closed.	<ul style="list-style-type: none"> Manual light control is ON. Door switch not making contact. 	<ul style="list-style-type: none"> Turn off manual light control. See “Operation” Section. Check for proper door alignment.
Alarm(s) will not shut off.	<ul style="list-style-type: none"> Door is ajar. Power has failed. Internal temperature is too high. (Beverage Center only) 	<ul style="list-style-type: none"> Press “Mute Sounds” key to acknowledge alarm. Ensure door is closed firmly. Allow 24 hours for temperature to stabilize.
Power is not restored after power failure.	<ul style="list-style-type: none"> Circuit breaker has tripped. 	<ul style="list-style-type: none"> Verify electrical supply. See “Installation” section.
Door does not close properly after reversing it.	<ul style="list-style-type: none"> Door hinges are misaligned. Door gasket is not sealing properly. 	<ul style="list-style-type: none"> Loosen hinges and re-align door. Retighten hinges. Turn gasket 180°. See “Door Reversal” section.

REFRIGERATOR WARRANTY *Your refrigerator is protected by this warranty*

	WARRANTY PERIOD	THROUGH OUR AUTHORIZED SERVICERS, WE WILL:	THE CONSUMER WILL BE RESPONSIBLE FOR:
FULL ONE-YEAR WARRANTY	One year from original purchase date.	Pay all costs for repairing or replacing any parts of this appliance which prove to be defective in materials or workmanship. Excludes original and replacement Ice & Water filter cartridges (if equipped). Original and replacement cartridges are warranted for 30 days (parts only).	Costs of service calls that are listed under NORMAL RESPONSIBILITIES OF THE CONSUMER.*
LIMITED 2ND - 5TH YEAR WARRANTY (Cabinet Liner and Sealed System)	Second through fifth years from original purchase date.	Repair or replace any parts in the cabinet liner or sealed refrigeration system (compressor, condenser, evaporator, dryer or tubing) which prove to be defective in materials or workmanship.	Costs for pickup and delivery of the appliance required because of service. Costs for labor, parts and transportation other than with respect to the cabinet liner or Sealed Refrigeration System.
LIMITED WARRANTY (Applicable to the State of Alaska)	Time periods listed above.	All of the provisions of the full warranties above and the exclusions listed below apply.	Costs of the technician's travel to the home and any costs for pick up and delivery of the appliance required because of service.

In the U.S.A., your appliance is warranted by Electrolux Home Products, Inc. We authorize no person to change or add to any of our obligations under this warranty. Our obligations for service and parts under this warranty must be performed by us or an authorized Electrolux Home Products, Inc. servicer. In Canada, your appliance is warranted by Electrolux Canada Corp.

***NORMAL RESPONSIBILITIES OF THE CUSTOMER**

This warranty applies only to products in ordinary household use, and the consumer is responsible for the items listed below:

1. Proper use of the appliance in accordance with instructions provided with the product.
2. Proper installation by an authorized servicer in accordance with instructions provided with the appliance and in accordance with all local plumbing, electrical and/or gas codes.
3. Proper connection to a grounded power supply of sufficient voltage, replacement of blown fuses, repair of loose connections or defects in house wiring.
4. Expenses for making the appliance accessible for servicing, such as removal of trim, cupboards, shelves, etc., which are not a part of the appliance when it was shipped from the factory.
5. Damages to finish after installation.
6. Replacement of light bulbs and/or fluorescent tubes (on models with these features).

EXCLUSIONS

This warranty does not cover the following:

1. CONSEQUENTIAL OR INCIDENTAL DAMAGES SUCH AS PROPERTY DAMAGE AND INCIDENTAL EXPENSES RESULTING FROM ANY BREACH OF THIS WRITTEN OR ANY IMPLIED WARRANTY.

Note: Some states do not allow the exclusion or limitation of incidental or consequential damages, so this limitation or exclusion may not apply to you.

2. Service calls which do not involve malfunction or defects in workmanship or material, or for appliances not in ordinary household use. The consumer shall pay for such service calls.
3. Damages caused by services performed by servicers other than Electrolux Home Products, Inc., Electrolux Canada Corp., or its authorized servicers; use of parts other than genuine Electrolux Home Products parts; obtained from persons other than such servicers; or external causes such as abuse, misuse, inadequate power supply or acts of God.
4. Products with original serial numbers that have been removed or altered and cannot be readily determined.

IF YOU NEED SERVICE

Keep your bill of sale, delivery slip, or some other appropriate payment record. The date on the bill establishes the warranty period should service be required. If service is performed, it is in your best interest to obtain and keep all receipts. This written warranty gives you specific legal rights. You may also have other rights that vary from state to state. Service under this warranty must be obtained by contacting Electrolux Home Products, Inc. or Electrolux Canada Corp.

This warranty only applies in the 50 States of the U.S.A. and Puerto Rico, and Canada. Product features or specifications as described or illustrated are subject to change without notice. All warranties are made by Electrolux Home Products, Inc. In Canada, your appliance is warranted by Electrolux Canada Corp.

USA

1-877-435-3287

Electrolux Major Appliances North America
P.O. Box 212378
Augusta, GA 30907

Canada

1-800-265-8352

Electrolux Canada Corp.
5855 Terry Fox Way
Mississauga, Ontario, Canada L5V 3E4