

INSTALLER: LEAVE THIS MANUAL WITH THE APPLIANCE.
CONSUMER: RETAIN THIS MANUAL FOR FUTURE REFERENCE.



INSTALLATION AND OPERATION INSTRUCTIONS

CERTIFIED UNDER CANADIAN AND AMERICAN NATIONAL STANDARDS: CR97-003 • CAN-2.21-M85 • IAS US. 4-96

OUTDOOR TORCH™

GSST8N
NATURAL GAS

GSST8P
PROPANE

Certified for Canada and United States using ANSI/CSA Methods.

SAFETY INFORMATION

! WARNING

If the information in these instructions are not followed exactly, a fire or explosion may result causing property damage, personal injury or loss of life.

- Do not store or use gasoline or other flammable vapors and liquids in the vicinity of this or any other appliance.

- WHAT TO DO IF YOU SMELL GAS:

- Do not try to light any appliance.
- Do not touch any electrical switch; do not use any phone in your building.
- Immediately call your gas supplier from a neighbour's phone. Follow the gas supplier's instructions.
- If you cannot reach your gas supplier, call the fire department.

- Installation and service must be performed by a qualified installer, service agency or the supplier.

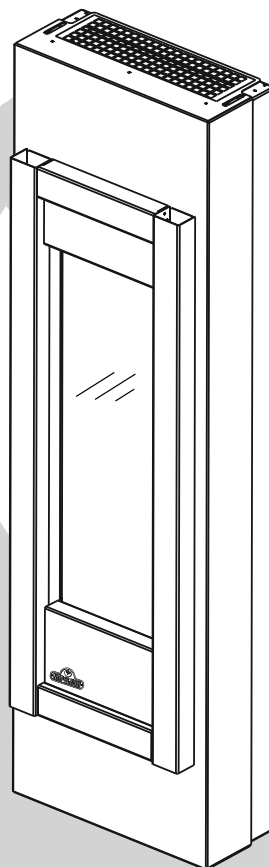

WARNING: FOR OUTDOOR USE ONLY



APPLY SERIAL NUMBER LABEL FROM CARTON



Serial No. X X X X X 0 0 0 0 0 0
MODEL NO.

Wolf Steel Ltd., 24 Napoleon Rd., Barrie, ON L4M 4Y8 Canada • (705)721-1212 • fax(705)722-6031
www.napoleonfireplaces.com • ask@napoleon.on.ca

TABLE of CONTENTS

PG 2-5	INTRODUCTION Warranty General Instructions General Information / Rates and Efficiencies Care of Glass and Plated Parts Dimensions	12	OPERATING INSTRUCTIONS
5-7	INSTALLATION Gas Installation Electrical Connection Clearance to Combustibles	13	MAINTENANCE Cleaning
8-11	FINISHING TMCSS Mounting Cabinet Installation Rain Tabs Door Removal Glass Removal TFSSO Frame Installation Logo Placement Accent Glass Installation LK8 Light Installation (Optional)	13	ADJUSTMENTS Gas Pressure Adjustment Venturi Adjustment Flame Characteristics
		14	REPLACEMENTS Replacement Parts Accessories
		15	TROUBLE SHOOTING GUIDE
		16	SERVICE HISTORY

! WARNING

Improper installation, adjustment, alteration, service or maintenance can cause injury or property damage. Read the installation, operating, and maintenance instructions thoroughly before installing or servicing this equipment.

! WARNING

- Do not burn wood or other materials in this enclosure.
- Adults and especially children should be alerted to the hazards of high surface temperatures and should stay away to avoid burns or clothing ignition. Supervise young children when they are in the same area as the enclosure.
- Clothing or other flammable material should not be placed on or near the enclosure.
- Due to high temperatures, the enclosure should be located out of traffic.
- Ensure you have incorporated adequate safety measure to protect infants/toddlers from touching hot surfaces.
- Even after the appliance is out, the glass and/or screen will remain hot for an extended period of time.
- Check with your local hearth specialty dealer for safety screens and hearth guards to protect children from hot surfaces.
- Any safety screen or guard removed for servicing must be replaced prior to operating the enclosure.
- It is imperative that the control compartments, burners and circulating blower and its passageway in the enclosure is kept clean. The appliance should be inspected before use and at least annually by a qualified service person. The enclosure area must be kept clear and free from combustible materials, gasoline and other flammable vapours and liquids.
- Under no circumstances should this enclosure be modified.
- Do not use this enclosure if any part has been under water. Immediately call a qualified service technician to inspect the enclosure and to replace any part of the control system and any gas control which has been under water.
- Do not operate the appliance with cracked or broken glass. Replacement of the glass should be done by a licensed or qualified service person.
- Do not strike or slam shut the enclosure glass doors.
- Provide adequate ventilation and combustion air. Refer to unvented room heaters installation instructions. Never obstruct the front opening of the enclosure.
- Furniture or other objects must be kept a minimum of 4 feet away from the front of the enclosure.
- Do not use a blower insert, heat exchanger insert or other accessory not approved for use with this enclosure.
- This appliance is only for use with the type of gas indicated on the rating plate.
- The gas log heater must be secured to the enclosure floor to ensure that the position is not changed while adjusting controls.
- Only doors / optional fronts certified with the unit are to be installed on the appliance.
- This enclosure uses and requires a fast acting thermocouple. Replace only with a fast acting thermocouple supplied by Wolf Steel Ltd.
- The burner must be replaced prior to the appliance being put into operation if it is evident the burner is damaged. Replace only with a burner supplied by Wolf Steel Ltd.

NOTE: Changes, other than editorial, are denoted by a line in the margin.

NAPOLEON® products are manufactured under the strict Standard of the world recognized ISO 9001 : 2000 Quality Assurance Certificate.

NAPOLEON® products are designed with superior components and materials, assembled by trained craftsmen who take great pride in their work. The burner and valve assembly are leak and test-fired at a quality test station. Once assembled the complete fireplace is thoroughly inspected by a qualified technician before packaging to ensure that you, the customer, receives the quality product that you expect from NAPOLEON®.

NAPOLEON® GAS FIREPLACE 5 YEAR LIMITED WARRANTY

All stainless steel components of your new NAPOLEON® gas fireplaces are warranted against defects for five years.

All parts such as gas valves, logs, gasketing are covered and NAPOLEON® will provide replacement parts free of charge during the first year of the limited warranty.

Labour related to warranty repair is covered free of charge during the first year. Repair work, however, requires the prior approval of an authorized company official. Labour costs to the account of NAPOLEON® are based on a predetermined rate schedule and any repair work must be done through an authorized NAPOLEON® dealer.

CONDITIONS AND LIMITATIONS

NAPOLEON® warrants its products against manufacturing defects to the original purchaser only -- i.e., the individual or legal entity (registered customer) whose name appears on the warranty registration card filed with NAPOLEON® -- provided that the purchase was made through an authorized NAPOLEON® dealer and is subject to the following conditions and limitations:

This limited warranty applies only while the unit remains at the site of original installation, and only if the unit is installed in Canada or the United States.

This factory warranty is nontransferable and may not be extended whatsoever by any of our representatives.

The enclosure must be installed by a licensed, authorized service technician or contractor. Installation must be done in accordance with the installation instructions included with the product and all local and national building and fire codes.

This limited warranty does not cover damages caused by misuse, lack of maintenance, accident, alterations, abuse or neglect and parts installed from other manufacturers will nullify this warranty.

This limited warranty further does not cover any scratches, dents, corrosion or discolouring caused by excessive heat, abrasive and chemical cleaners, mechanical breakage of PHAZER™ logs and embers.

In the first year only, this warranty extends to the repair or replacement of warranted parts which are defective in material or workmanship provided that the product has been operated in accordance with the operation instructions and under normal conditions.

After the first year, with respect to this Limited Warranty, NAPOLEON® may, at its discretion, fully discharge all obligations with respect to this warranty by refunding to the original warranted purchaser the wholesale price of any warranted but defective part(s).

After the first year, NAPOLEON® will not be responsible for installation, labour or any other costs or expenses related to the reinstallation of a warranted part, and such expenses are not covered by this warranty.

Notwithstanding any provisions contained in this Limited Warranty, NAPOLEON'S responsibility under this warranty is defined as above and it shall not in any event extend to any incidental, consequential or indirect damages.

This warranty defines the obligations and liability of NAPOLEON® with respect to the NAPOLEON® gas fireplace and any other warranties expressed or implied with respect to this product, its components or accessories are excluded.

This limited warranty does not cover damages resulting from the use of components not supplied with the fireplace, or the use of fuel other than those specified.

NAPOLEON® neither assumes, nor authorizes any third party to assume, on its behalf, or any other liabilities with respect to the sale of this product. NAPOLEON® will not be responsible for: over-firing, inadequate ventilation, insufficient makeup air, or negative air pressures which may or may not be caused by mechanical systems such as exhaust fans, furnaces, clothes dryers, etc.

Any damages to fireplace due to weather, long periods of dampness, condensation, damaging chemicals or cleaners will not be the responsibility of NAPOLEON®.

The bill of sale or copy will be required together with a serial number and a model number when making any warranty claims from your authorized dealer. The warranty registration card must be returned within fourteen days to register the warranty.

NAPOLEON® reserves the right to have its representative inspect any product or part thereof prior to honouring any warranty claim.

ALL SPECIFICATIONS AND DESIGNS ARE SUBJECT TO CHANGE WITHOUT PRIOR NOTICE DUE TO ON-GOING PRODUCT IMPROVEMENTS. NAPOLEON® IS A REGISTERED TRADEMARK OF WOLF STEEL LTD. PATENTS U.S. 5.303.693.801 - CAN. 2.073.411, 2.082.915. © WOLF STEEL LTD.

GENERAL INSTRUCTIONS

THIS GAS APPLIANCE SHOULD BE INSTALLED AND SERVICED BY A QUALIFIED INSTALLER to conform with local codes. Installation practices vary from region to region and it is important to know the specifics that apply to your area, for example: in Massachusetts State:

- The appliance off valve must be a "T" handle gas cock.
- The flexible connector must not be longer than 36 inches.
- **WARNING:** This product must be installed by a licensed plumber or gas fitter when installed within the commonwealth of Massachusetts.

In absence of local codes, install to the current CAN/CGA -B149 Installation Code in Canada or to the National Fuel Gas Code, ANSI Z223.1, and NFPA 54 in the United States.

The appliance and its individual shutoff valve must be disconnected from the gas supply piping system during any pressure testing of that system at test pressures in excess of 1/2 psig (3.5 kPa). The appliance must be isolated from the gas supply piping system by closing its individual manual shutoff valve during any pressure testing of the gas supply piping system at test pressures equal to or less than 1/2 psig (3.5 kPa).



We suggest that our gas hearth products be installed and serviced by professionals who are certified in the U.S. by the National Fireplace Institute® (NFI) as NFI Gas Specialists.

GENERAL INFORMATION

FOR YOUR SATISFACTION, THIS APPLIANCE HAS BEEN TEST-FIRED TO ASSURE ITS OPERATION AND QUALITY!

RATES AND EFFICIENCIES

	NATURAL GAS	PROPANE GAS
Altitude	0 - 4,500*	0 - 4,500*
Maximum Input	6,000	6,000
Minimum Inlet Gas Supply Pressure	4.5" Water Column	11" Water Column
Maximum Inlet Gas Supply Pressure	7" Water Column	13" Water Column
Manifold Pressure Under Flow Conditions	3.5" Water Column	10" Water Column

*** When the appliance is installed at elevations above 4,500ft, and in the absence of specific recommendations from the local authority having jurisdiction, the certified high altitude input rating shall be reduced at the rate of 4% for each additional 1,000ft.**

This appliance is only for use with the type of gas indicated on the rating plate. This appliance is not convertible for use with other gases, unless a certified kit is used.

Expansion / contraction noises during heating up and cooling down cycles are normal and are to be expected.

Purge all gas lines with the glass door of the appliance removed. Assure that a continuous gas flow is at the burner before replacing the door.

Objects placed in front of the appliance must be kept a minimum of 48" from the front face of the unit.

Use only authorized accessories designed for and listed with the model.

CARE OF GLASS AND PLATED PARTS

The glass is 3/16" tempered glass, available from your authorized dealer. Clean the glass after the first 10 hours of operation with a recommended gas appliance glass cleaner. Thereafter clean as required. **DO NOT CLEAN GLASS WHEN HOT!** Do not use abrasive cleaners to clean plated parts. Buff lightly with a clean dry cloth. If the glass is not kept clean permanent discoloration and / or blemishes may result.

! WARNING



**HOT GLASS
WILL CAUSE BURNS.
DO NOT TOUCH
GLASS UNTIL COOLED.
NEVER
ALLOW CHILDREN TO TOUCH GLASS.**

DO NOT SUBSTITUTE MATERIALS. USE CARE WHEN HANDLING GLASS COMPONENTS. DO NOT STRIKE, OR SLAM SHUT. DO NOT OPERATE WITH BROKEN GLASS.

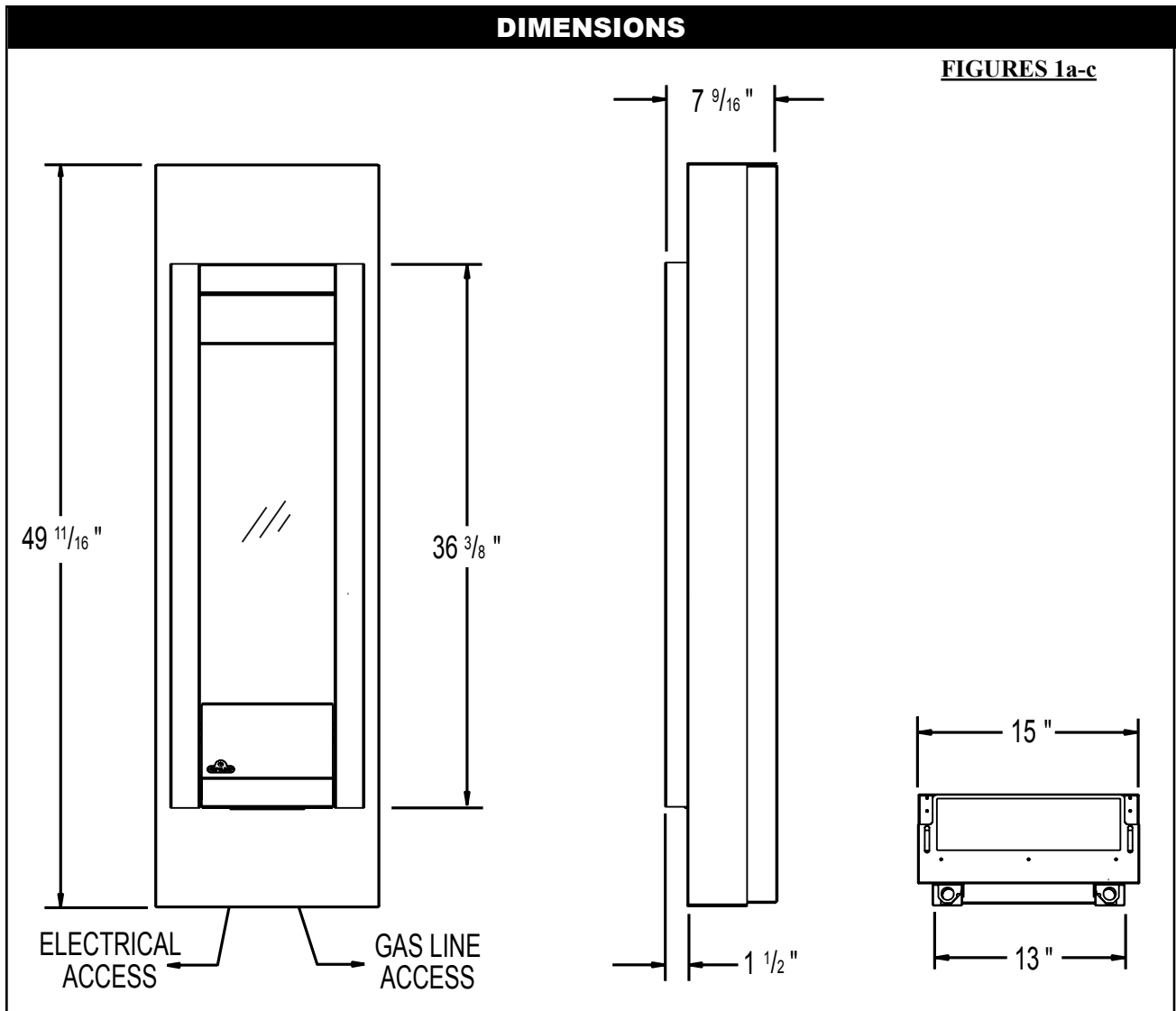

INSTALLATION

GAS INSTALLATION

Note: All gas connections must be contained within the appliance when complete.

1. The appliance is designed to accept a 1/2" gas supply line. The appliance is equipped with a 1/2" manual shut-off valve.
2. The access to the gas inlet is located in the bottom of the cabinet.
3. The shut off valve / flex connector assembly must always be contained within the cabinet.
4. When flexing any gas line, support the gas valve so that the lines are not kinked.
5. Check for gas leaks by brushing on a soap and water solution.

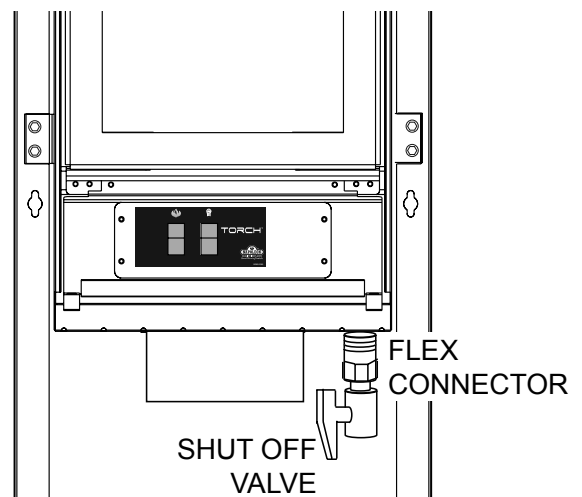

ELECTRICAL CONNECTION

! WARNING

RISK OF ELECTRIC SHOCK!
Control and valve operate with 110v.

Do NOT use the appliance if any part has been under water. Call a qualified service technician IMMEDIATELY to have the appliance inspected for damage to the electrical circuit.

HARD WIRING CONNECTION

IT IS NECESSARY TO HARD WIRE THIS APPLIANCE.

This appliance must be electrically connected and grounded in accordance with local codes. In the absence of local codes, use the current CSA C22.1 CANADIAN ELECTRICAL CODE in Canada or the ANSI/NFPA 70-1996 NATIONAL ELECTRICAL CODE in the United States.

NOTE: During assembly, anti-oxidant compound was applied to all electrical connections. If replacing the existing wire harness or disconnecting any connectors, it is highly recommended to re-apply anti-oxidant compound to the relative connections.

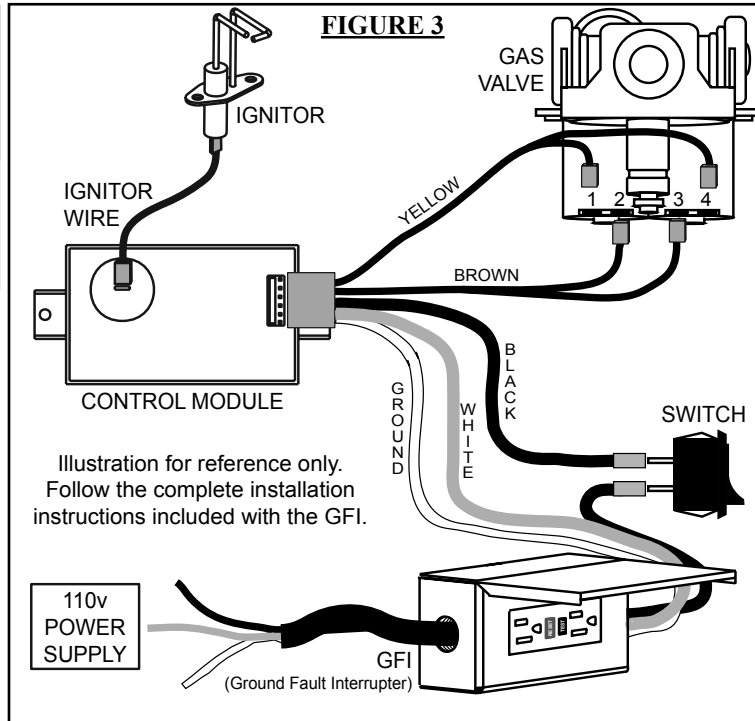

CLEARANCES TO COMBUSTIBLES

! WARNING

The GSST8 is designed for outdoor application only. The unit must be installed in the cabinet provided. The cabinet is designed to be installed on finished surfaces.

The GSST8 can be recessed into a structure a maximum of 12" provided that all clearances are maintained.

The GSST8 cabinet may be installed directly onto a combustible surface.

MINIMUM CLEARANCES TO COMBUSTIBLES:

- 18" to top
- 1" to sides
- 8" to bottom
- 0" to rear

FIGURE 4

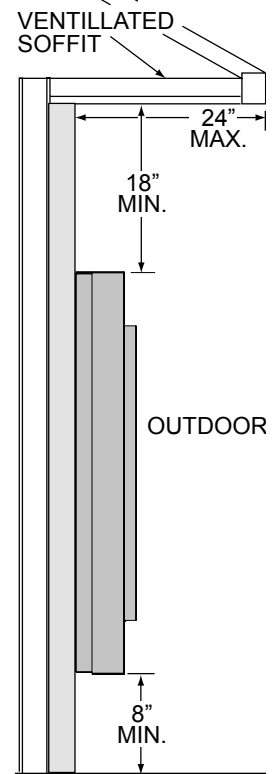

COMBUSTION AND VENTILLATION AIR

This fireplace is intended for installation on an outdoor patio or in your yard. It must never be installed inside the warm air envelope of your structure.

It is highly recommended that this fireplaces be installed in a "sheltered" area. Direct wind will cause an erratic flame and possible pilot or main burner outage.

An erratic flame could also lead to excessive carboning (black soot), this condition is not a safety issue but is visually undesirable.

Typical installation may include covered patio, screened porch, gazebo, or on an outside wall of a house.

NOTE: Ensure the area has adequate ventilation.

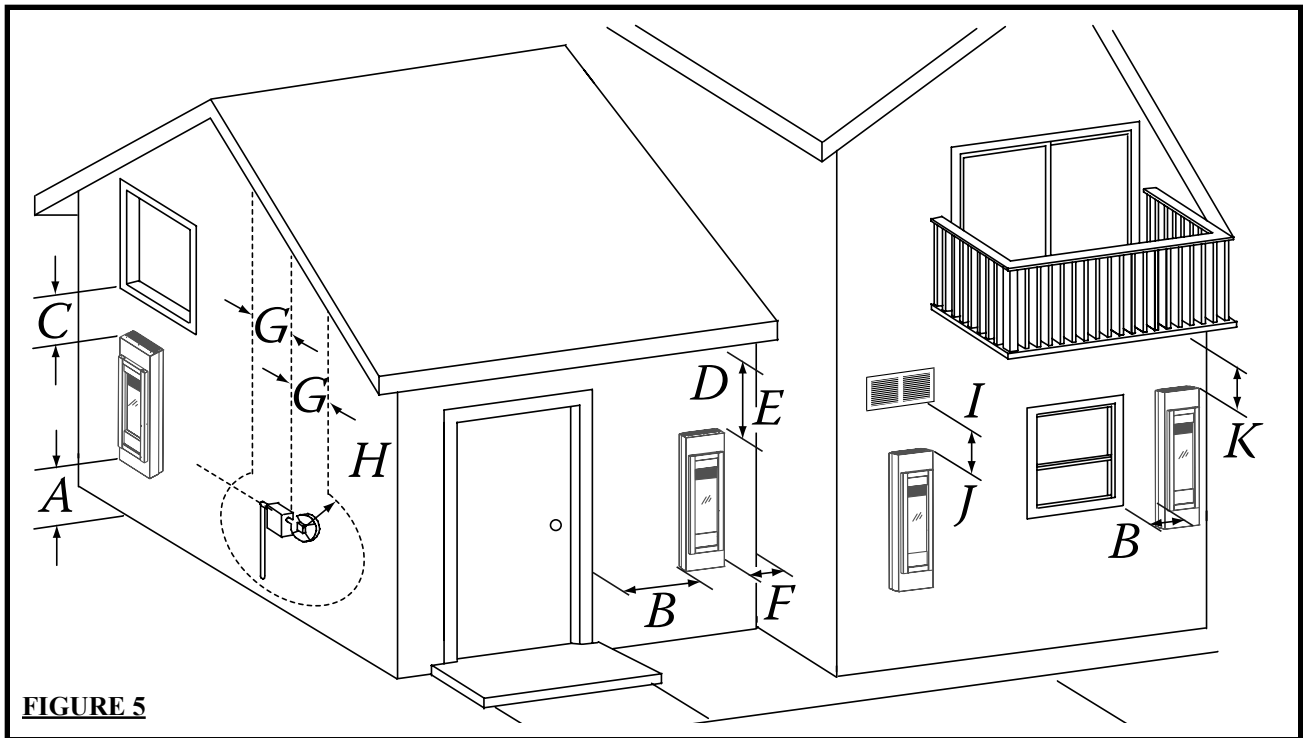

FIGURE 5

INSTALLATIONS			
	CANADA	U.S.A.	
A	8 INCHES	8 INCHES	Clearance above grade, veranda porch, deck or balcony.
B	12 INCHES	9 INCHES	Clearance to windows or doors that open.
C	12 INCHES*	12 INCHES*	Clearance to permanently closed windows.
D	18 INCHES**	18 INCHES**	Vertical clearance to ventilated soffit.
E	12 INCHES**	12 INCHES**	Vertical clearance to an unventilated soffit.
F	1 INCH	1 INCH	Clearance to an inside combustible corner wall or protruding combustible obstructions. (vent chase, etc.)
G	3 FEET	3 FEET***	Clearance to each side of the centre line extended above the metre/regulator assembly to a maximum vertical distance of 15 ft.
H	3 FEET	3 FEET***	Clearance to a service regulator vent outlet.
I	12 INCHES	9 INCHES	Clearance to a non-mechanical air supply inlet to the building or a combustion air inlet to any other appliance.
J	6 FEET	3 FEET****	Clearance to a mechanical air supply inlet.
K	12 INCHES†	12 INCHES***	Clearance under a veranda, porch, deck or balcony.

* Recommended to prevent condensation on windows and thermal breakage.

** It is recommended to use a heat shield and to maximize the distance to vinyl clad soffits.

*** This is a recommended distance. For additional requirements check local codes.

**** Three feet above if within 10 feet horizontally.

† Permitted only if the veranda, porch, or deck is fully open on a minimum of two sides beneath the floor.

FINISHING

TMCSS MOUNTING CABINET INSTALLATION

! WARNING

Before starting the installation remove the protective layer from all three components that make up the GSST8 (cabinet, frame, and Torch)

NOTE: It is recommended that all fasteners be stainless steel.

1. Using the installation template (W122-0401) supplied, determine the best mounting location for your new Torch. (refer to your manual for clearances) Mark all 14 hole centres on the wall (surface) using the template.

2. Remove the template. Depending on the surface and fasteners, drill the appropriate holes. Hold the Torch up, aligning the mounting brackets to the mounting holes. Secure the Torch to the wall using the appropriate fasteners. **NOTE: The Torch has been designed to have a 1/2" clearance between the rear outer panel and the mounting surface.**

3. Start the fasteners into each of the six remaining mounting holes. Align the keyholes of the frame to the heads of the fasteners and slide the frame down onto the fasteners. Ensure the frame is plumb and level before tightening the fasteners. **NOTE: It is recommended that the gas and electrical be connected to the appliance at this stage. Both must enter the appliance at the opening created between the bottom of the Torch and the bottom of the mounting frame.**

4. Slide the front of the cabinet over the mounting frame, ensuring the "mesh" is to the top. Start each of the four screws (supplied) through the slots. Once the cabinet has been adjusted for depth the four screws can be tightened.

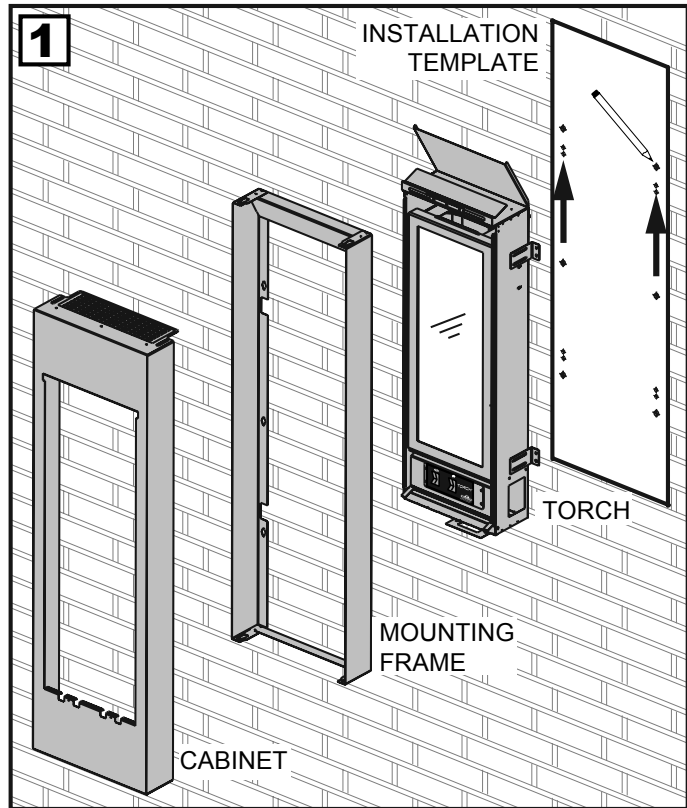
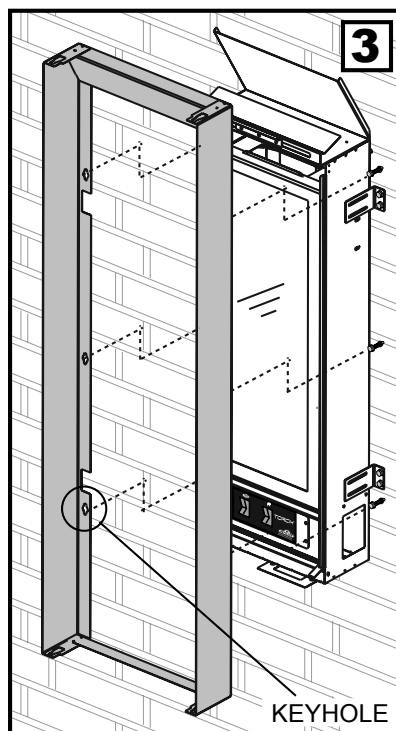
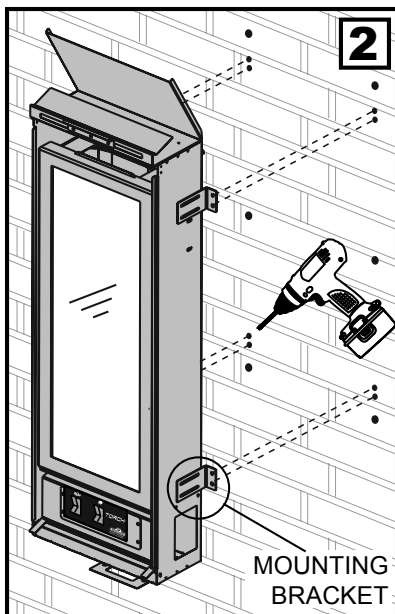
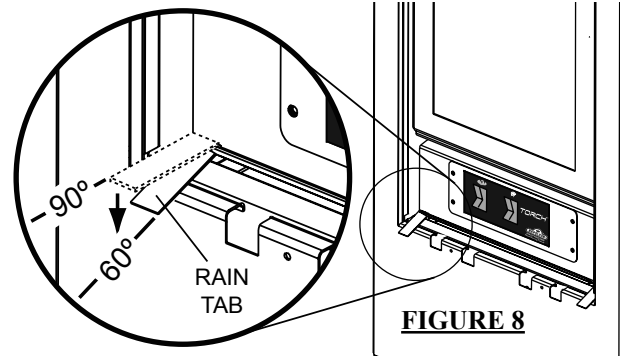

FIGURE 6



RAIN TABS

When shipped, the rain tabs should be at a 90° angle. Push the rain tabs down until they are at an approximate 60° angle to assist rain in running off and out of the unit.



DOOR REMOVAL

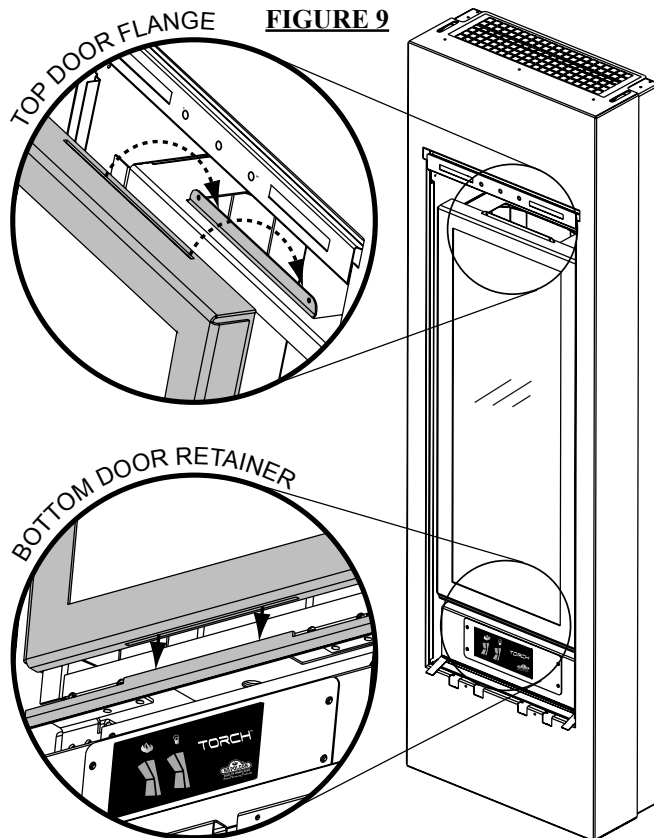

The door is held in place at the bottom by a retainer tab that inserts into a slot in the bottom edge of the door, and at the top with a tab that secures in the same fashion. The door is removed by lifting it off the tabs. When replacing, guide the door over the upper tab first, then over the lower tab.

SECURING THE DOOR IN PLACE

When shipped, the door is secured with two hitch pins along the top edge, replacing them is optional. To secure the door in place use the supplied hitch pins as illustrated.

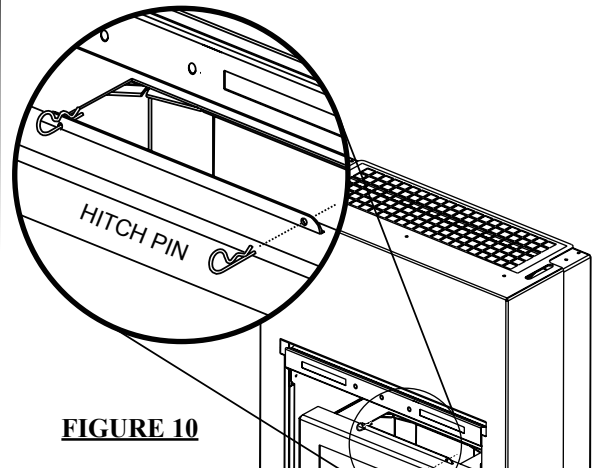

GLASS REMOVAL

Having removed the door, lay on a smooth flat surface, face down. There are 4 glass retainers that need to be bent away from the glass to release it from the frame. Do not pry on the glass.

When replacing **DO NOT SUBSTITUTE MATERIAL**, replace the gasket (W562-0008) and the glass (W300-0110). Set new glass into the frame and gently bend tabs into the gasket to secure.

* Ensure that the gasketed end of the glass is placed into the top of the door frame.

NOTE: Care must be taken when removing and disposing of any broken glass or damaged components. Be sure to vacuum up any broken glass from inside the appliance before operation.

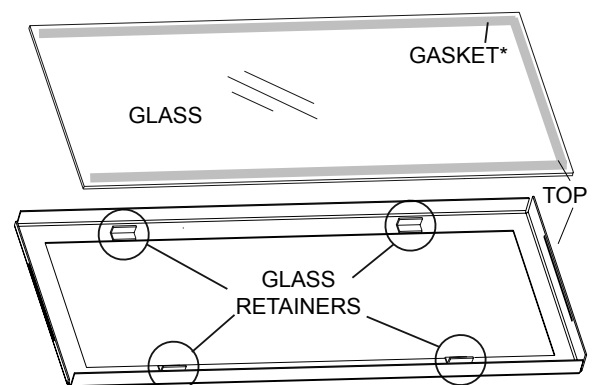

TFSSO FRAME INSTALLATION

1. Hang the frame onto the firebox by engaging the top trim bracket into the slot in the top of the frame and the bottom hooks of the frame into the slot in the mounting cabinet.

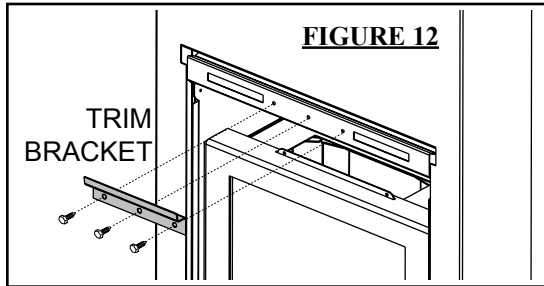

FIGURE 12

2. Install the trim bracket supplied in your manual baggie to the firebox using 3 screws.

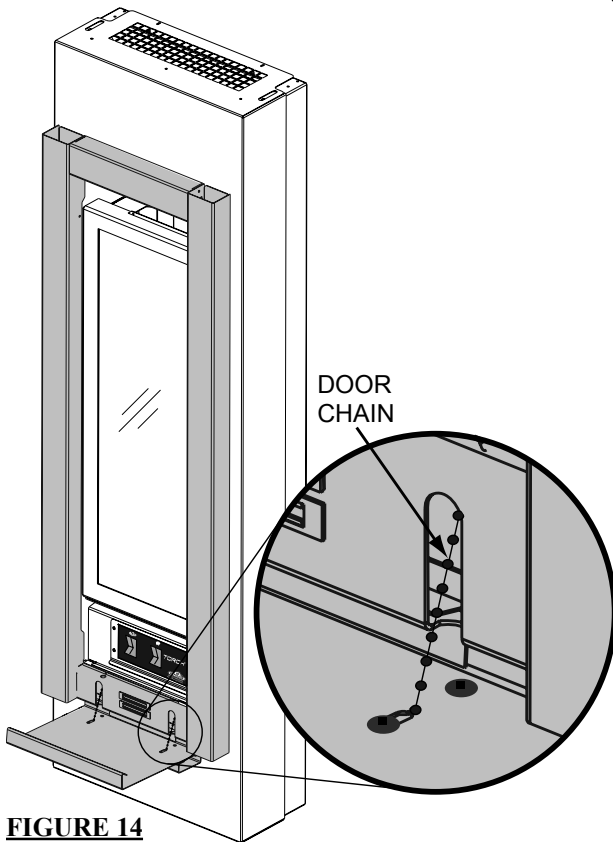
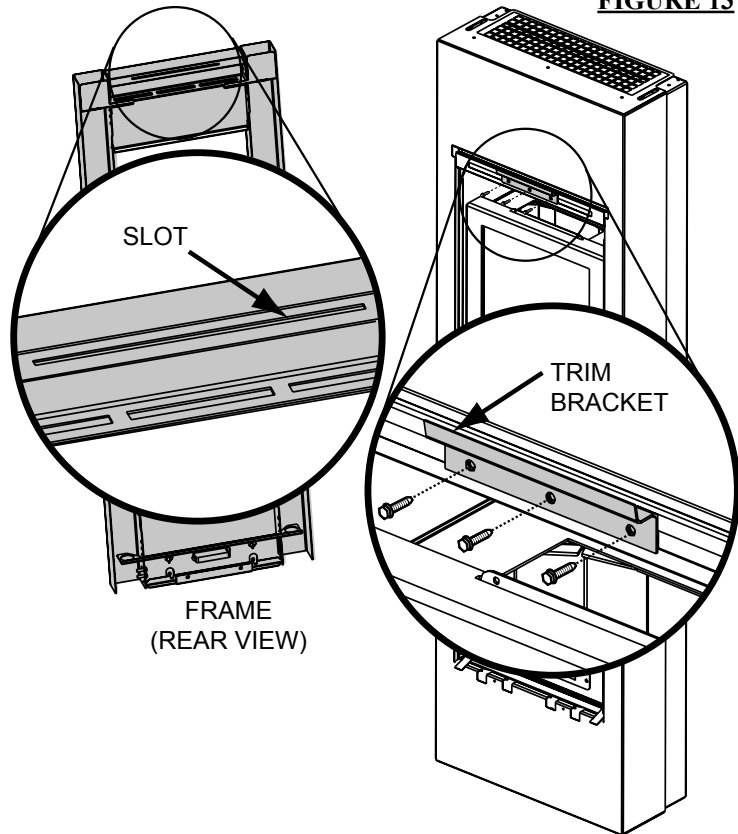

FIGURE 14

FIGURE 13



NOTE: If the frame needs to be secured, use two screws in the holes provided behind the control door.

Insert the door stop chain into the receiving slot in the control door. Then insert the door chain into the receiving slot in the frame so that when fully opened the control door has a clearance of 1/8" to the mounting cabinet.

NOTE: In most cases a count of 15 balls on the chain between receiving slots will be sufficient.

LOGO PLACEMENT

With the control door closed, affix the logo to the front face of the control door at the bottom left corner.

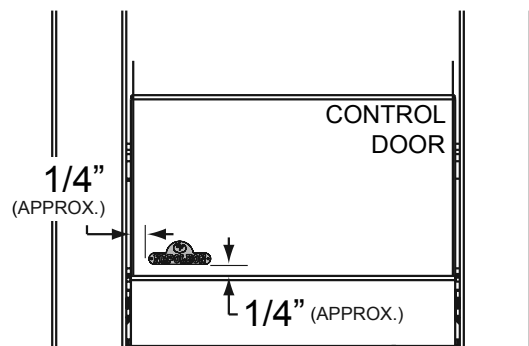
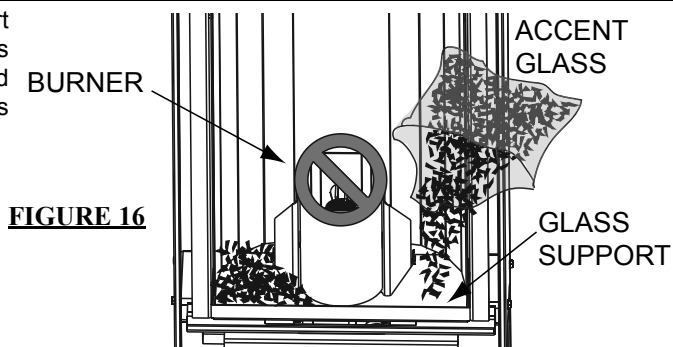

FIGURE 15

ACCENT GLASS INSTALLATION

Carefully sprinkle the accent glass onto the glass support evenly. Ensure no glass falls into the burner area. If this happens, insert a clean bag into your vacuum cleaner and vacuum out the accent glass. Replacement accent glass can be purchased from your authorized dealer.



LK8 LIGHT INSTALLATION (OPTIONAL)

1. Turn off the electrical and gas supply to the appliance.
2. Remove the frame from the unit by removing the the 2 stainless steel hex head securing screws from the bottom and lifting the frame off of the top trim bracket.
3. Lay the frame down on its front, being careful not to scratch the finish.
4. Starting at the top of the frame, take one light assembly and carefully snap it into place in the hole provided. Repeat for each of the light assemblies. The wires on the top 2 light assemblies will need to be fed in behind the heat shields.

Note: When installing the light kit be careful not to scratch your fingers on any of the exposed screws in the frame.

5. Connect the light assemblies to the appropriate flags on the wire harness. The wire harness is labeled (TR) top right, (BR) bottom right (TL) Top left and (BL) bottom left.

6. Secure the wires into the clips at both sides and the bottom of the frame. Use the extra clips provided to retain any loose wires.

7. Re-attach frame onto unit.

8. Open the control panel door, leave the wires connected to the ON/OFF switch and place the transformer into the bottom of the unit. Plug the transformer into the receptacle.

9. Attach one of the wire leads from the transformer to the lead on the wire harness labeled "TRANS", and the other to the ON/OFF switch. Attach the last lead on the wire harness labeled "SWI" to the ON/OFF switch.

10. Close the control panel door.

11. Turn on the gas supply and electrical power.

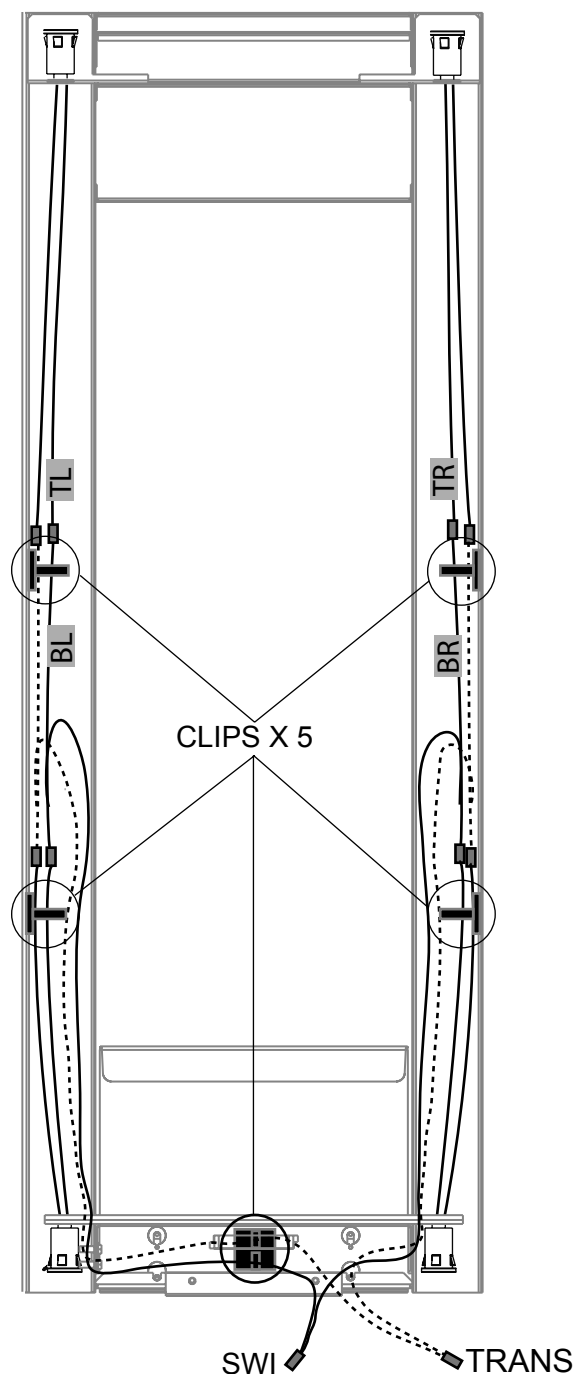

OPERATING INSTRUCTIONS

If the appliance keeps shutting off, have it serviced. Keep burner and control compartment clean.

When lit for the first time, the fireplace will emit a slight odour for a few hours. This is a normal temporary condition caused by the curing "burn-in" of internal paints and lubricants used in the manufacturing process and will not occur again.

After extended periods of non-operation such as following a vacation or a warm weather season, the fireplace may emit a slight odour for a few hours. This is caused by dust particles burning off.

Always shut off the fireplace, gas to the fireplace and allow the fireplace to cool before servicing it.

FOR YOUR SAFETY READ BEFORE LIGHTING:

- A.** This appliance is equipped with an ignition device which automatically lights the burner. Do not try to light by hand.
- B.** Before operating, smell all around the appliance area for gas and next to the floor because some gas is heavier than air and will settle on the floor.
- C.** Do not use this appliance if any part has been under water. Immediately call a qualified service technician to inspect the appliance and replace any part of the control system and any gas control which has been under water.

WHAT TO DO IF YOU SMELL GAS:

- Turn off all gas to the appliance.
- Do not try to light any appliance.
- Do not touch any electrical switch; do not use a mobile or land phone.
- Immediately call your gas supplier from a neighbor's phone. Follow the gas supplier's instructions.
- If you cannot reach your gas supplier, call the fire department.

LIGHTING INSTRUCTIONS

1. **STOP!** Read the safety information located above.
2. Turn off all electric power to the appliance.
3. This appliance is equipped with an ignition device which automatically lights the burner. Do not try to light by hand.
4. Remove the glass door.
5. Wait five (5) minutes to clear out any gas. If you smell gas including near the floor **STOP!** Follow "B" in the above safety information on this label. If you don't smell gas go to the next step.
6. Replace the glass door.

7. Turn on all electric power to the appliance.
8. Turn the appliance switch to the ON position.
9. If appliance will not operate, follow instructions "To Turn Off Gas" and call your service technician or gas supplier.

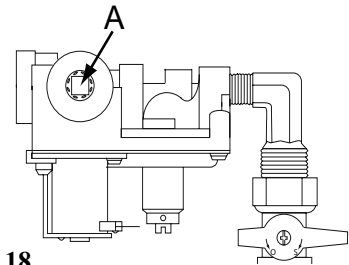



FIGURE 18

TO TURN OFF GAS

1. Turn the appliance switch to the OFF position.
2. Turn off all electrical power to the appliance if service is to be preformed.
3. Turn manual shut-off valve clockwise to off. Do not force.

RATING PLATE

RATING LABEL LOCATION:
The rating label is located under the control panel and is chained to the appliance.
DO NOT REMOVE.



REFERENCE
W/N 16036

CERTIFIED UNDER : CR97-003-M85, IAS US 4-96 OUTDOOR GAS FIREPLACE
IF APPLIANCE HAS BEEN SUPPLIED WITH A GAS PRESSURE REGULATOR, IT MUST BE USED. THE GAS SUPPLY MUST BE TURNED OFF AT THE LP-GAS SUPPLY CYLINDER WHEN THIS APPLIANCE IS NOT IN USE. DO NOT STORE OR USE GASOLINE OR OTHER FLAMMABLE VAPORS AND LIQUIDS IN THE VICINITY OF THIS OR ANY OTHER APPLIANCE. IMPROPER INSTALLATION, ADJUSTMENT, ALTERATION, SERVICE OR MAINTENANCE CAN CAUSE INJURY OR PROPERTY DAMAGE. REFER TO THE OWNER'S MANUAL PROVIDED WITH THIS APPLIANCE. FOR ASSISTANCE OR ADDITIONAL INFORMATION, CONSULT A QUALIFIED INSTALLER, SERVICE AGENCY OR GAS SUPPLIER. MUST NOT BE USED FOR COOKING. FOR OUTDOOR USE ONLY. IF STORED INDOORS, DETACH AND LEAVE CYLINDER OUTDOORS.

MODEL
GSST8N

(NATURAL GAS)
0-4500FT (0-1370m)
6,000 BTU/h
#56

CERTIFIED FOR CANADA AND USA

MODEL
GSST8P

(PROPANE)
0-4500FT (0-1370m)
6,000 BTU/h
#69

ALTITUDE
INPUT
ORIFICE

MANIFOLD PRESSURE: 3.5" WATER COLUMN
MINIMUM SUPPLY PRESSURE: 4.5" WATER COLUMN
MAXIMUM SUPPLY PRESSURE: 7.0" WATER COLUMN

MANIFOLD PRESSURE: 10" WATER COLUMN
MINIMUM SUPPLY PRESSURE: 11" WATER COLUMN
MAXIMUM SUPPLY PRESSURE: 13" WATER COLUMN

WARNING: DO NOT ADD ANY MATERIAL TO THE APPLIANCE, WHICH WILL COME IN CONTACT WITH THE FLAMES, OTHER THAN THAT SUPPLIED BY THE MANUFACTURER WITH THE APPLIANCE.

NOT FOR USE WITH SOLID FUEL. FOR USE WITH GLASS DOOR. CERTIFIED WITH THIS UNIT ONLY.

THIS APPLIANCE IS ONLY FOR USE WITH THE TYPE OF GAS INDICATED ON THE RATING PLATE. THIS APPLIANCE IS NOT CONVERTIBLE FOR USE WITH OTHER GASES, UNLESS A CERTIFIED KIT IS USED.

MINIMUM CLEARANCES TO COMBUSTIBLE MATERIALS

TOP	18"	BACK	0"
SIDES	1"	FLOOR	8"

TOP, SIDES & BACK AS PER ABOVE. FOR FINISHING MATERIAL, SEE OWNERS MANUAL.

ELECTRICAL RATING: 115v 0.82AMP, 60HZ

MADE IN CANADA
WOLF STEEL LTD, BARRIE, ON, CANADA

SERIAL NUMBER:

W385-0420

MAINTENANCE

TURN OFF THE GAS AND ELECTRICAL POWER BEFORE SERVICING THE APPLIANCE.

CAUTION: Label all wires prior to disconnection when servicing controls. Wiring errors can cause improper and dangerous operation. Verify proper operation after servicing. This appliance should be inspected before use and at least annually by a qualified service person. The appliance area must be kept clear and free of combustible materials, gasoline or other flammable vapours and liquids. The flow of combustion and ventilation air must not be obstructed.

1. Keep the control compartment, burner, and air shutter opening clean by vacuuming or brushing, *at least once a year*.
2. Check to see that the main burner ignites when the switch for the burner is turned on. A 5 second light-up period is satisfactory. If ignition takes longer, consult your authorized dealer.
3. Check that the gasketing on the sides and top of the door are not broken or missing. Replace if necessary.

CLEANING

- Visually inspect the appliance for carbon buildup.
- Using a small whisk or brush, brush off the excess carbon and vacuum up or sweep into the garbage.
- Check the fireplace for corrosion of the main burner base.

Cleaning Stainless Steel: Do not use abrasive cleaners to clean any painted, porcelain or stainless steel parts. To clean stainless surfaces, use a stainless steel cleaner or a non-abrasive cleaner. Always wipe in the direction of the grain. Do not use steel wool, as it will scratch the finish. Stainless steel parts will discolour when heated, usually to a golden or brown colour. This discoloration is normal and will not affect the performance of the fireplace.

ADJUSTMENTS

GAS PRESSURE ADJUSTMENT

Outlet pressure can be adjusted if not measuring 3.5" W.C. (NG) or 10.0" W.C. (LP).

1. Pressure can be checked by removing cap (A) using a 3/16 allen key and replacing it with a 1/8 NPT barb fitting.

2. Place pressure gauge tube over the fitting.

3. Pressure can be adjusted by removing cap (B) using a flat screwdriver, and adjusting the nylon plug with the same screw driver. Turning the plug in (clockwise) will increase the pressure.

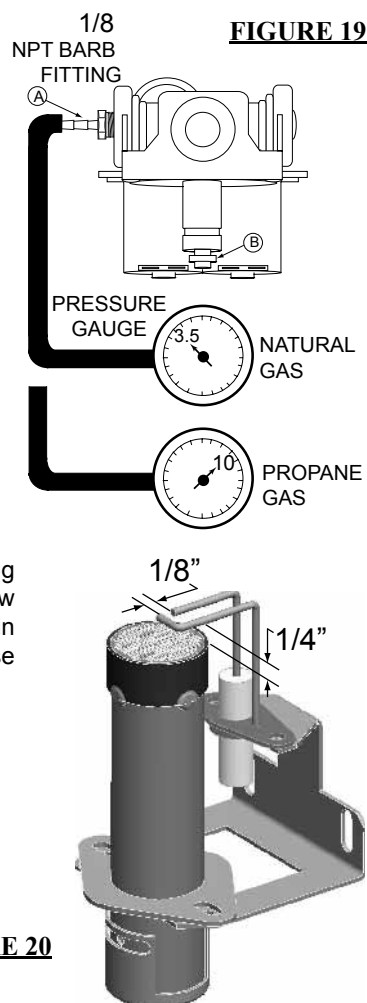

FIGURE 20

VENTURI ADJUSTMENT

Closing the air shutter will cause a more yellow flame, but can lead to carboning. Opening the air shutter will cause a more blue flame, but can cause flame lifting from the burner. The flame may not appear yellow immediately; allow 15 to 30 minutes for the final flame color to be established.

FIGURE 21

AIR SHUTTER OPENINGS

LP	3/16" DIA
NG	1/16" DIA

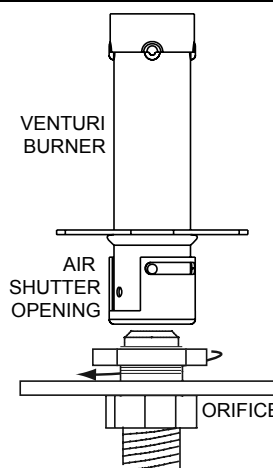

NOTE: It is important that the venturi sits down tight on the orifice. The burner is adjustable up/down to ensure this. The electrode sensors should be located 1/4" above the burner for proper operation.

FLAME CHARACTERISTICS

It is important to periodically perform a visual check of the burner flame. Compare them to the illustration provided.

FIGURE 22

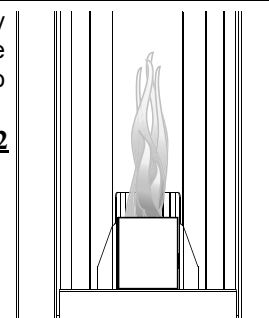

REPLACEMENTS

Contact your dealer for questions concerning prices and availability of replacement parts. Normally all parts can be ordered through your authorized dealer or distributor. When ordering replacement parts always give the following information:

1. MODEL & SERIAL NUMBER OF APPLIANCE
2. INSTALLATION DATE OF APPLIANCE
3. PART NUMBER
4. DESCRIPTION OF PART
5. FINISH

! WARNING

Failure to position the parts in accordance with these diagrams or failure to use only parts specified approved with this appliance may result in property damage or personal injury.

FOR WARRANTY REPLACEMENT PARTS, A PHOTOCOPY OF THE ORIGINAL INVOICE WILL BE REQUIRED TO HONOUR THE CLAIM.

*** IDENTIFIES ITEMS WHICH ARE NOT ILLUSTRATED. FOR FURTHER INFORMATION, CONTACT YOUR AUTHORIZED DEALER.**

REPLACEMENT PARTS

#	PART NO.	DESCRIPTION
1	W225-0223	DOOR FRAME
2*	W562-0008	DOOR GASKET
3	W010-1959	GLASS c/w GASKET
4*	W300-0110	GLASS
5	W100-0111	BURNER
6	W357-0006	IGNITOR
7	W190-0026	CONTROL, MODULE
8*	W750-0202	WIRE HARNESS
9*	W750-0184	IGNITION CABLE
10	W200-0263	IGNITOR COVER
11	W200-0262	BURNER COVER
12	W725-0052	NATURAL GAS VALVE - 3.5" W.C.
12	W725-0053	PROPANE GAS VALVE - 10.0" W.C.
13*	W455-0085	#56 NATURAL GAS ORIFICE
13*	W455-0086	#69 PROPANE GAS ORIFICE
14	W475-0590	BACK PANEL
15*	W300-0108	ACCENT GLASS (BLACK)
16*	W385-0334	NAPOLEON® LOGO
17*	W562-0046	ROPE GASKET, BACK PANEL
18	W475-0595	CONTROL PANEL
19*	W385-0380	CONTROL PANEL LABEL
20	W660-0082	OUTDOOR ON/OFF SWITCH

ACCESSORIES

21	TMCSS	MOUNTING CABINET
22	TFSSO	FRAME KIT
23*	LK8	LIGHT KIT
24*	W573-0002	HIGH TEMPERATURE SEALANT
25*	W573-0007	HIGH TEMPERATURE SEALANT
26*	W175-0270	CONVERSION KIT - NG TO LP
27*	W175-0274	CONVERSION KIT - LP TO NG

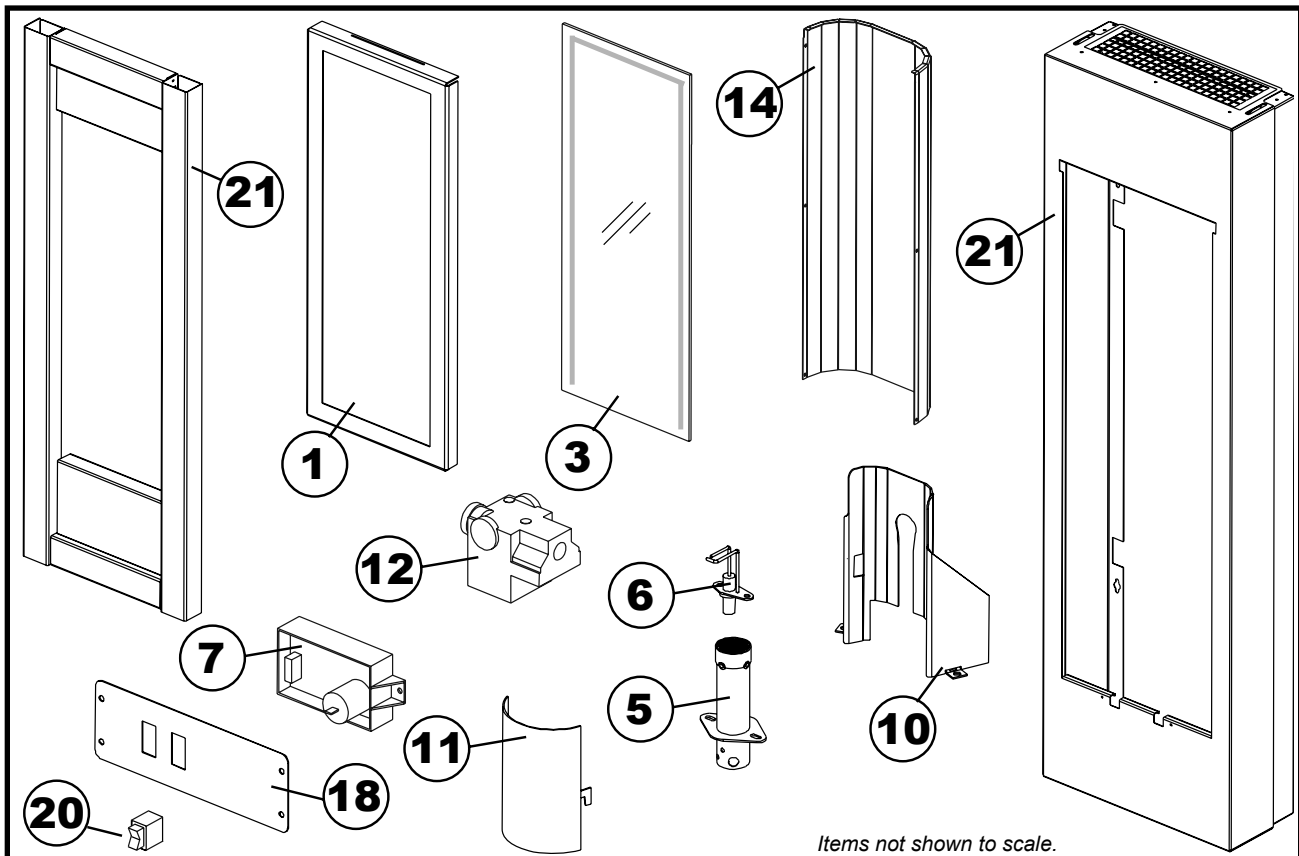

TROUBLE SHOOTING GUIDE

BEFORE ATTEMPTING TO TROUBLESHOOT, PURGE YOUR UNIT AND INITIALLY LIGHT THE IGNITOR AND THE MAIN BURNER WITH THE GLASS DOOR REMOVED.

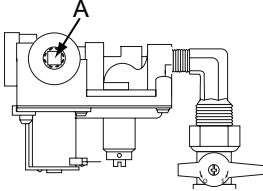
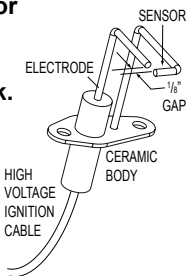
SYMPTOM	PROBLEM	TEST SOLUTION
Electrode sparks, burner ignites, electrode continues to spark for complete 7 seconds, burner shuts down.	Hot and neutral wires are reversed at control module. Sensor / flame not connecting	<ul style="list-style-type: none"> - Connect the hot wire to the black wire. Connect the neutral wire to the white wire. - Raise electrode / sensor up into flame 1/4" above the burner.
Flame length consistently too large or too small. Carboning occurs.	Unit is over-fired or under-fired. 	<ul style="list-style-type: none"> - Check pressure readings - Outlet pressure can be checked by removing cap (A) and replacing it with a 1/8" NPT barb fitting. Next, place pressure gauge tubing over the fitting. Gauge should read 3.5" W.C. for natural gas or 10.0" W.C. for propane. AFTER TAKING PRESSURE READINGS, BE SURE TO REPLACE CAP TO RESEAL. DO NOT OVER-TORQUE. - Leak test with a soap and water solution.
Carbon is being deposited on glass, and combustion chamber surfaces.	Air shutter has become blocked. Flame is impinging on the combustion chamber.	<ul style="list-style-type: none"> - Ensure air shutter opening is free of lint or other obstructions. - Open air shutter to increase the primary air. - Check the input rate: check the manifold pressure and orifice size as specified by the rating plate values.
White / grey film forms.	Sulphur from fuel is being deposited on glass, logs or combustion chamber surfaces.	<ul style="list-style-type: none"> - Clean the glass with a gas appliance glass cleaner. DO NOT CLEAN GLASS WHEN HOT. If deposits are not cleaned off regularly, the glass may become permanently marked.
No gas to the main burner; switch is on.	Switch is defective. Burner orifice is blocked. Control valve faulty. Faulty valve.	<ul style="list-style-type: none"> - Connect a jumper wire across the wall switch terminals; if main burner lights, replace switch. - Remove stoppage in orifice. - Replace. - Replace.
Burner will not light, ignitor sparks.	No gas at the burner. Out of propane gas.	<ul style="list-style-type: none"> - Check that the manual valve is turned on. - Replace the valve. - Fill the tank.
Electrode does not spark. Burner does not light.	GFCI has been tripped.	<ul style="list-style-type: none"> - Push reset button (red) on the face of the GFCI.
Ignitor will not spark. 	No spark at ignitor. Spark gap is incorrect.	<ul style="list-style-type: none"> - Check the power source. (ie. fuse, circuit breaker, GFCI reset button.) - Check that the wire is connected to both the ignitor and the control module. - Check that the spark is not jumping to ignitor cover. - Replace the wire if the wire insulation is broken or frayed. - Replace the electrode if the ceramic insulator is cracked or broken. - Spark gap should be 0.125" (1/8" approx.) from the electrode tip to the sensor tip.
Remote wall switch is in "OFF" position; burner comes on.	Wall switch is mounted upside down. Remote wall switch is grounding. Remote wall switch wire is grounding. Faulty wire.	<ul style="list-style-type: none"> - Reverse. - Replace. - Check for ground (short); repair ground or replace wire. - Replace.

WOLF STEEL Fireplace Service History

This fireplace must be serviced annually depending on usage

DATE	DEALER NAME	SERVICE TECHNICIAN NAME	SERVICE PERFORMANCE	SPECIAL CONCERNS