

Panasonic[®]

Operating Manual High Speed Color Scanner

Model No. KV-S5055C

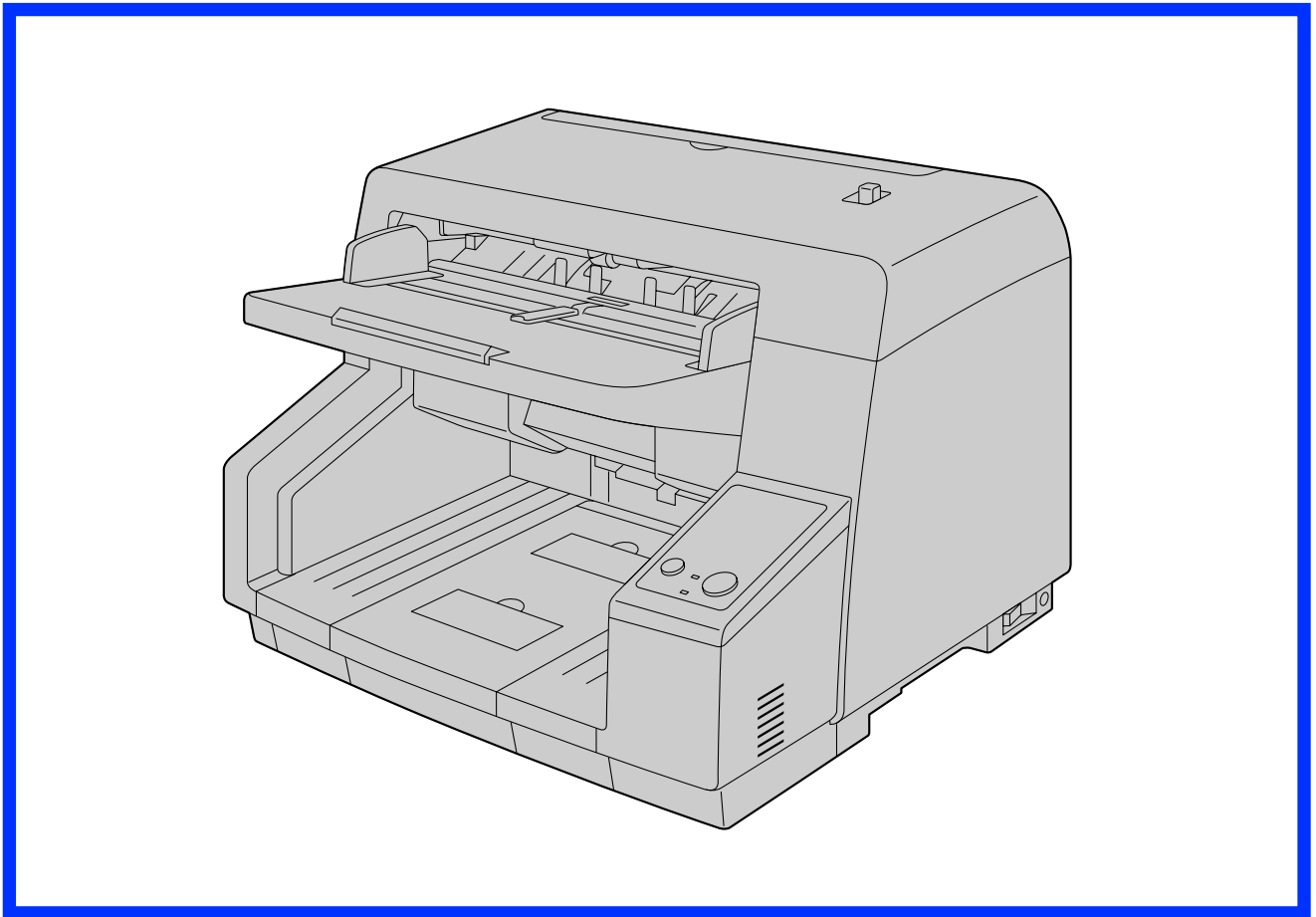

These instructions contain information on operating the scanner. Before reading these instructions, please read the installation manual enclosed with this unit.

Please carefully read these instructions and the enclosed installation manual. Keep all documentation in a safe place for future reference.

Introduction

Thank you for purchasing a Panasonic High Speed Color Scanner.

Feature Highlights

Superior Paper Feeding

- This scanner features an advanced paper-feeding mechanism that adjusts the pressure of the rollers and the amount of time that the rollers are applied to the document according to the condition of the document. As a result, this scanner can scan a wide range of paper weights, from very thin 20 g/m² (5 lbs.) paper to very thick 157 g/m² (42 lbs.) paper.

High-speed Double Sided Scanning

- This scanner can scan documents at high speed, regardless of the image type (monochrome / color).
Single sided: 90 pages/minute, double sided: 180 images/minute (200 dpi)
Single sided: 60 pages/minute, double sided: 120 images/minute (300 dpi)
* Speeds based on scanning A4 size paper in landscape orientation.

Support for High-efficiency Scanning Jobs

- Self-cleaning function
This scanner contains an ionizer that, by emitting ions, reduces the amount of paper dust that accumulates on the scanning glass. This scanner also has self-cleaning brushes that clean paper dust off of the scanner glass.
- Stapled document detection
This scanner has a stapled document detection function that detects documents that contain staples and stops scanning before any serious damage occurs.
- Double feed detection
This scanner contains ultrasonic sensors that detect double feeding. Double feeding can be detected even if you scan documents that contain paper of various thicknesses.
- Double Feed Skip (DFS) function
If scanning has been stopped because a double feed was detected, you can easily resume scanning by pressing the Double Feed Skip key (DFS key). When you scan documents that include items that you do not want to be detected as double feeding (for example, documents that have receipts attached, envelopes, etc.), the double feed detection function can be enabled and still scan these documents.

Other Features

- You can set the left and right document guides independently. By doing so, you can reliably scan documents of differing paper sizes.
- The paper feed path can be opened widely to easily removed jammed paper and perform maintenance.

About the documentation

The scanner documentation consists of 2 manuals: the Installation Manual and the Operating Manual. In addition, each piece of software includes the help.

Installation Manual (printed documentation)	The Installation Manual explains the installation method and procedures.
Operating Manual (this manual)	The Operating Manual explains the part names, operations, features and maintenance of the unit.
Software help	<ul style="list-style-type: none"> • You can view explanations about the settings for Panasonic Image Enhancement Technology (PIE) functions that are available on the ISIS driver screen and on the TWAIN driver screen by clicking the help button that appears on each of the software's operation screen. • You can view explanations about the settings for Image Capture Plus (ICP) by clicking the help button that appears on the software's operation screen. • You can view explanations for User Utility, which is used for maintenance, by clicking the help button that appears on the software's operation screen.

- You can also view the help for ICP and User Utility from the Windows Start menu. For details about viewing the help, see "Viewing Manuals Installed On Your Computer" in the Installation Manual.

Abbreviations

- Windows® refers to the Microsoft® Windows® operating system (hereafter Windows).
- Windows® XP refers to the Microsoft® Windows® XP operating system (hereafter Windows XP).
- Windows Vista® refers to the Microsoft® Windows Vista® operating system (hereafter Windows Vista).
- Windows® 7 refers to the Microsoft® Windows® 7 operating system (hereafter Windows 7).

Trademarks

- Microsoft, Windows, and Windows Vista are either registered trademarks or trademarks of Microsoft Corporation in the United States and/or other countries.
- ISIS and QuickScan are registered trademarks or trademarks of EMC Corporation in the United States and other countries.
- IBM and AT are trademarks of International Business Machines Corporation in the United States, other countries, or both.
- Intel and Intel Core are trademarks of Intel Corporation in the U.S. and other countries.
- Adobe and Reader are either registered trademarks or trademarks of Adobe Systems Incorporated in the United States and/or other countries.
- All other trademarks identified herein are the property of their respective owners.

International ENERGY STAR Program



As an ENERGY STAR® Partner, Panasonic has determined that this product meets the ENERGY STAR guidelines for energy efficiency.

System Requirements

Computer	IBM® PC/AT® or compatible machine with a CD-ROM drive
CPU	Intel® Core™ 2 Duo, 1.8 GHz or higher
Operating System	Windows XP / Windows Vista / Windows 7
Interface	USB 2.0
Memory	1 GB or higher
Hard Disk	5 GB or more free space is required.

Note

- The above system requirements may not satisfy the requirements of all operating systems.
- The scanning speed differs depending on the host computer's operating environment or the application used.
- Due to the slower speed of USB 1.1, it is recommended to use a USB 2.0 interface.
- If you connect the scanner to a USB hub, it is not guaranteed to work.

Federal Communications Commission Requirements (For United States only)

Note

This equipment has been tested and found to comply with the limits for a Class A digital device, pursuant to Part 15 of the FCC Rules. These limits are designed to provide reasonable protection against harmful interference when the equipment is operated in a commercial environment. This equipment generates, uses, and can radiate radio frequency energy and, if not installed and used in accordance with the instruction manual, may cause harmful interference to radio communications. Operation of this equipment in a residential area is likely to cause harmful interference in which case the user will be required to correct the interference at his own expense.

FCC Warning: To assure continued FCC compliance, the user must use only shielded interface cable and the provided power supply cord. Also, any unauthorized changes or modifications to this equipment would void the user's authority to operate this device.

For FRG Users (For Germany Only)

- Machine noise information regulation - 3.GPSGV, the maximum sound pressure level is 70 dB(A) or less, in conformity with EN ISO 7779.
- This device is not intended for use in the direct field of view at visual display workplaces. To avoid incommoding reflexions at visual display workplaces this device must not be placed in the direct field of view.

Table of Contents





Before You Start	8
For Your Safety	8
Safety Information (For United Kingdom only)	11
Precautions	12
Location of Controls	14
Main Unit	14
Control Panel and Status Indicators	16
Operation	18
Turning on the Scanner Power	18
Preparing Documents	19
Acceptable Documents	19
Unacceptable Documents	21
Scanning Documents	22
Scanning Documents with Pages of the Same Size	23
Scanning Documents with Pages of Different Sizes	30
Using Control Sheets	40
About Printing Control Sheets	41
Changing the Scan Background Color	43
Switching the Reference Plate	43
Care and Maintenance	46
Clearing Paper Jams	46
Cleaning the Scanner	49
Outside of the Scanner	49
Inside of the Scanner	51
Cleaning the Conveyor	53
Cleaning the Rollers	56
Cleaning the Sensors and Scanning Glass	60
Replacement Parts and Optional Units	64
Replacement Parts and Optional Units	64
Replacing Parts	65
Replacing the Paper Feed Roller Module	65
Replacing the Double Feed Prevention Roller	69
Installing Optional Units	74
Installing the Imprinter Unit	74
Installing the Ink Cartridge	77
Removing the ink cartridge	79
Printing	80
Appendix	81
Troubleshooting	81
Shading Adjustment	84
Repacking Instructions	85
Specifications	87

Index.....89

For Your Safety

To prevent severe injury and loss of life, read this section carefully before using the unit to ensure proper and safe operation of your unit.

- This section explains the graphic symbols used in this manual.

 WARNING	Denotes a potential hazard that could result in serious injury or death.
 CAUTION	Denotes hazards that could result in minor injury or damage to the unit.
	These symbols are used to alert operators to a specific operating procedure that must be performed carefully.
	These symbols are used to alert operators to a specific operating procedure that must not be performed.
	These symbols are used to alert operators to a specific operating procedure that must be emphasized in order to operate the unit safely.

For Users



WARNING

Power and Ground Connection

- 

The power source voltage of this unit is listed on the nameplate. Only plug the unit into an AC outlet with the proper voltage. If you use a cord with an unspecified current rating, the unit or plug may emit smoke or become hot to the touch.
- 

When you operate this product, the power outlet should be near the product and easily accessible.
- 

To ensure safe operation, the power cord supplied must be inserted into a standard three-prong AC outlet which is effectively grounded (earthed) through the normal wiring.
- 

The fact that the equipment operates satisfactorily does not imply that the power point is grounded (earthed) and that the installation is completely safe. For your safety, if in any doubt about the effective grounding (earthing) of the power point, consult a qualified electrician.
- 

If the plug cannot be inserted into the AC outlet, contact a licensed electrician to replace the AC outlet with a properly grounded (earthed) one.
- 

Do not defeat the grounding (earthing) plug (ex. do not use a conversion plug).
- 

Plug the power cord firmly into an AC outlet. Otherwise, it can cause fire or electric shock.
- 

Do not pull, bend, rest objects on, or chafe the power cord and plug. Damage to the power cord or plug can cause fire or electric shock.



Do not attempt to repair the power cord or plug. If the power cord or plug is damaged or frayed, contact your dealer for a replacement.



Ensure that the plug connection is free of dust. In a damp environment, a contaminated connector can draw a significant amount of current that can generate heat, and eventually cause fire if left unattended over an extended period of time.



Never touch the plug with wet hands. Danger of electric shock exists.



Stop operation immediately if the unit emits smoke, excessive heat, abnormal smell, or unusual noise. These conditions can cause fire or electric shock. Immediately turn the unit off, and unplug the power cord, and contact your dealer for service.



When disconnecting the unit, grasp the plug instead of the cord. Pulling on a cord forcibly can damage it, and cause fire or electric shock.

Operating Safeguards



If metal fragments or water gets into the unit, turn the unit off, and unplug the unit immediately. Contact your dealer for service. Operating the contaminated unit can cause fire or electric shock.



Do not open covers, and do not attempt to repair the unit yourself. Contact your dealer for service.



Do not alter the unit or modify any parts. Alteration or modification can cause fire or electric shock.



During thunderstorms, do not touch the unit and plug. It may cause an electric shock.

Roller Cleaning Paper



Do not use the roller cleaning paper near a heater or open flame.



Do not drink or inhale the roller cleaning paper fluid including isopropyl alcohol.



The roller cleaning paper may be harmful to sensitive skin. Please use protective gloves.

CAUTION

Power



The unit should be used only with the power cord enclosed with the unit.



When the unit is not used over an extended period of time, switch it off, and unplug it. If an unused unit is left connected to a power source for a long period, degraded insulation may cause electric shock, current leakage, or fire.

Installation and Relocation



Do not position the unit in a location where it is unstable.



To prevent fire or shock hazard, do not expose this unit to rain or any type of moisture.



Do not place the unit in a hot humid or dusty environment. Prolonged exposure to these adverse conditions may cause fire or electric shock.



Do not block the air vents. Doing so can cause heat to build up, and may result in fire.



When moving the unit, be sure to unplug the power cord from the AC outlet. If the unit is moved with the power cord attached, it can cause damage to the cord which could result in fire or electric shock.



Do not use the exit tray hanging out of a table.



When carrying the unit, do not use the trays as handles.



Make sure that the unit is installed in a well ventilated room so as not to increase density of ozone in the air. Since ozone is heavier than air, it is recommended that air at floor level be ventilated.



Move this unit with two persons, and hold it by both side grips. Dropping the unit can cause injury and damage to the unit.



Operating Safeguards



If the unit falls down or gets damaged, turn the unit off, and unplug the power cord. Otherwise, it may cause fire or electric shock.



Do not place any liquids or heavy items on the unit. Accidental spillage of liquid into the unit may cause severe damage. If this occurs, turn the unit off, unplug the power cord, and contact your dealer for service.





Do not touch the scanning glass or their surroundings immediately after continuous scanning. This area is very hot and can cause burns.



Be careful not to pinch your fingers when closing the ADF door. It can cause injury.

Safety Information (For United Kingdom only)

This appliance is supplied with a moulded three pin mains plug for your safety and convenience. A 5 amp fuse is fitted in this plug. Should the fuse need to be replaced, please ensure that the replacement fuse has a rating of 5 amps and that it is approved by ASTA or BSI to BS1362. Check for the ASTA mark  or the BSI mark  on the body of the fuse. If the plug contains a removable fuse cover, you must ensure that it is refitted when the fuse is replaced. If you lose the fuse cover, the plug must not be used until a replacement cover is obtained. A replacement fuse cover can be purchased from your local Panasonic Dealer.

IF THE FITTED MOULDED PLUG IS UNSUITABLE FOR THE SOCKET OUTLET IN YOUR PREMISES, THEN THE FUSE SHOULD BE REMOVED AND THE PLUG CUT OFF AND DISPOSED OF SAFELY. THERE IS DANGER OF SEVERE ELECTRICAL SHOCK IF THE CUT-OFF PLUG IS INSERTED INTO ANY 13 AMP SOCKET.

If a new plug is to be fitted, please observe the wiring cord as shown below. If in any doubt, please consult a qualified electrician.

WARNING

THIS APPLIANCE MUST BE EARTHED.

IMPORTANT

The wires in this mains lead are coloured as follows:

Green-and-Yellow	: Earth
Blue	: Neutral
Brown	: Live

As the colours of the wires in the mains lead of this apparatus may not correspond with the coloured markings identifying the terminals in your plug, proceed as follows.

The wire that is coloured GREEN-AND-YELLOW must be connected to the terminal in the plug that is marked with the letter E or by the Earth symbol  or coloured GREEN or GREEN-AND-YELLOW.

The wire that is coloured BLUE must be connected to the terminal in the plug that is marked with the letter N or coloured BLACK.

The wire that is coloured BROWN must be connected to the terminal in the plug which is marked with the letter L or coloured RED.

How to replace the fuse:

Open the fuse compartment with a screwdriver and replace the fuse and fuse cover.

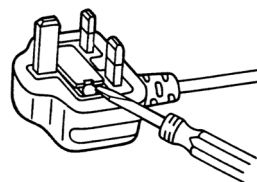

OR

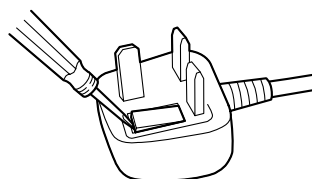

Precautions

Installation

- Do not place the unit in direct sunlight, in a cold draft, or near heating apparatus.
- Do not place the unit near apparatus which generate electronic or magnetic noise.
- Protect the unit from static electricity.
- Do not move the unit immediately from a cold place to a warm place. It may cause dew.

CD-ROM

- Do not write or stick paper on the front and/or back of CD-ROM.
- Do not touch the data side of the CD-ROM. When handling the CD-ROM, be careful not to leave fingerprints or otherwise damage the CD-ROM.
- Do not leave the CD-ROM where it is directly exposed to sunlight or near a heater for extended periods.
- Do not throw or bend the CD-ROM.

Roller Cleaning Paper

- Keep the roller cleaning paper out of reach of small children.
- Do not store the roller cleaning paper in direct sunlight or in a place with a temperature over 40 °C (104 °F).
- Only use the roller cleaning paper to clean the rollers and scanning glass.
- For details about the roller cleaning paper, please refer to the Material Safety Data Sheet (MSDS). Please ask your Panasonic sales company about obtaining the Material Safety Data Sheet.

KEEP AWAY FROM FIRE.

Others

- Make sure to remove paper clips and staples from documents before scanning. Failing to do so can damage the unit, document, or both.
- Do not use thinner, benzene, or cleaners containing abrasives or surfactants, for cleaning the outside of scanner.
- Plug the power cord into an outlet from which you can easily unplug it.

Illegal Duplication

It is unlawful to make duplication of certain documents.

Duplicating certain documents may be illegal in your country/area.

Penalties of fines and/or imprisonment may be imposed on those found guilty. The following are examples of items that may be illegal to duplicate in your country/area.

- Currency
- Bank notes and checks
- Bank and government bonds, and securities
- Passports, licenses, official or private documents, identification cards, and the like
- Copyright materials, or trademarks without the consent of the owner
- Postage stamps, and other negotiable instruments

This list is not inclusive, and no liability is assumed for either its completeness or accuracy. In case of doubt, contact your legal counsel.

Notice

Install your machine near a supervised area to prevent illegal duplication from being made.

Security Notice

The management of documents and scanned data is the responsibility of the user. In particular, pay attention to the following points.

- Make sure you have the same number of pages for important documents both before and after scanning, and take care not to leave any pages in the scanner.
- Periodically back up important data.
- When having your computer or hard disk serviced, or when disposing of your computer or hard disk, completely erase any stored image data.

Main Unit

Front

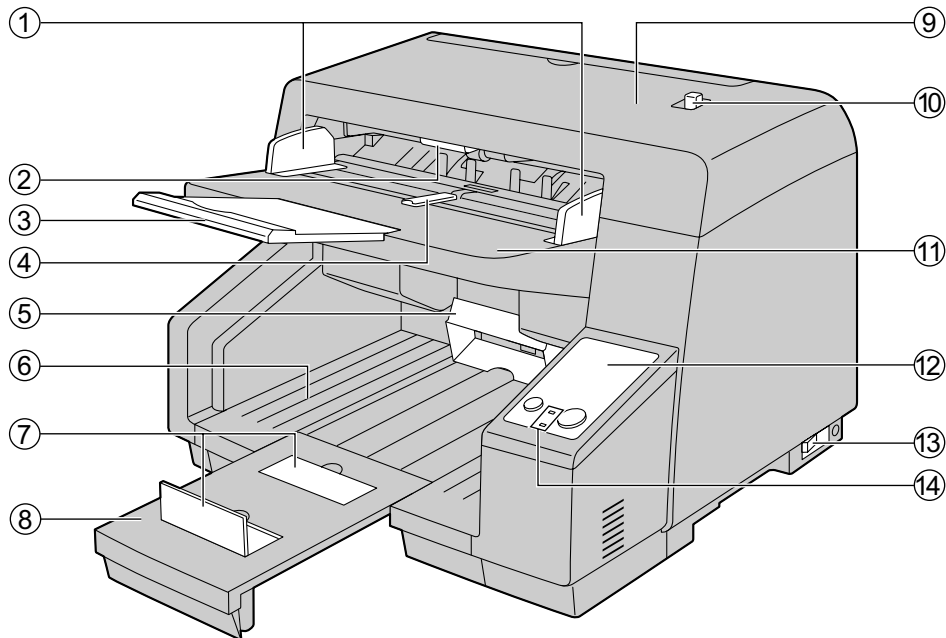

- ① **Document guides**
- ② **ADF door release**
- ③ **Hopper extension tray**
- ④ **Document guides selector**
- ⑤ **Exit sub guide**
- ⑥ **Exit tray**
- ⑦ **Exit stopper**
- ⑧ **Extension sub tray**
- ⑨ **ADF door**
- ⑩ **Manual feed selector**
Switches the scanning method between continuous scanning (Auto) and manual scanning (Manual).
- ⑪ **Hopper**
- ⑫ **Control Panel**
For details, refer to "Control Panel and Status Indicators" (page 16).
- ⑬ **Power switch**
- ⑭ **Ready indicator / Error indicator**
For details, refer to "Control Panel and Status Indicators" (page 16).

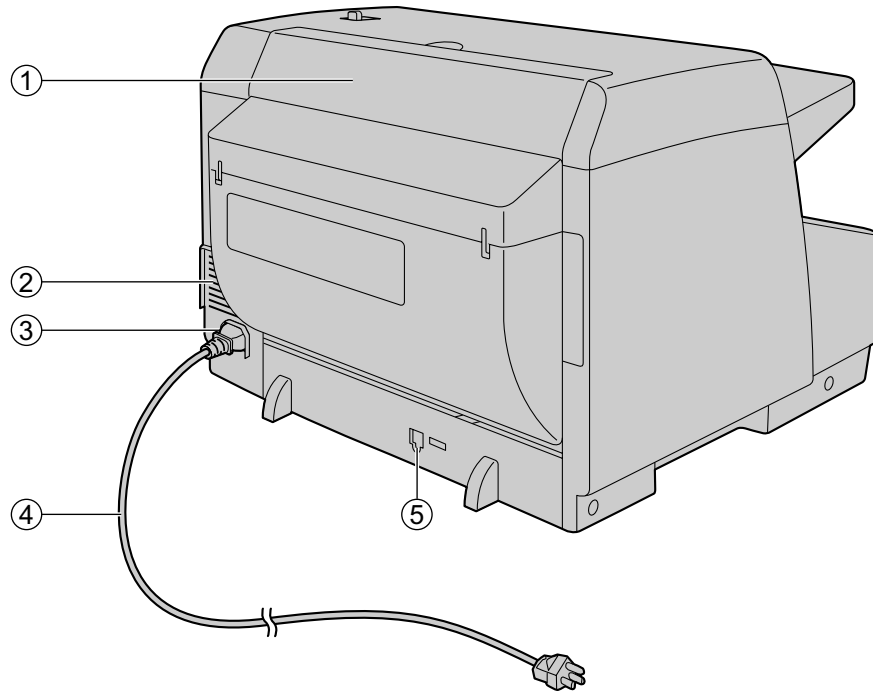
Rear**① Imprinter door**

You open this door when installing an imprinter unit (sold separately) or ink cartridge. For details on installing an imprinter, refer to "Installing the Imprinter Unit" (page 74).

② Fan exhaust vent**③ AC inlet****④ Power cord**

Plugs may vary in shape depending on country/area.

⑤ USB connector

Control Panel and Status Indicators

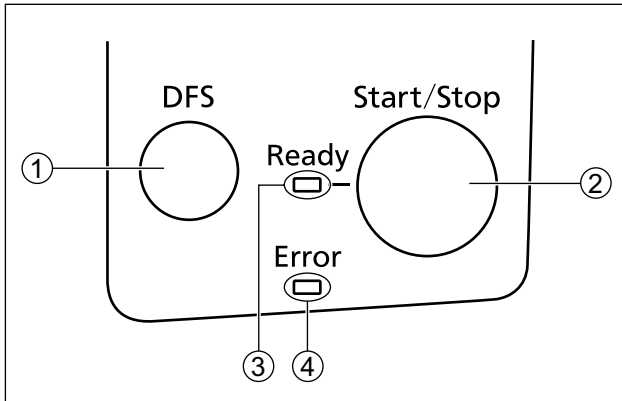

① **Double Feed Skip key (DFS)**

If you press this key when a double feed occurs, the sheet that was detected as a double feed will be scanned, and scanning will continue.

② **Start/Stop key (Start/Stop)**

- If you set [Wait Key] for "Manual Feed Mode"^{*1} in your application software, pushing this key starts scanning.
- During scanning, pushing this key stops scanning.
- If you press this key when a double feed occurs, the sheet that was detected as a double feed will be ejected from the scanner without being scanned. Scanning will stop.

③ **Ready indicator (Ready)**

Shows the scanner's status.

④ **Error indicator (Error)**

Lights when an error occurs.

*1 For details on "Manual Feed Mode", refer to the help for ICP.

The status of the scanner is displayed by the ready indicator (③) and the error indicator (④), as shown in the table below:

③ Ready indicator (Green)	④ Error indicator (Red)	Status
ON	OFF	Ready
ON	Blink (Slow)	Caution ^{*1}
OFF	ON	Error ^{*1}
Blink (Slow)	OFF	Sleep
Blink (Slow)	Blink (Slow)	Caution ^{*1} / Sleep
Blink (Fast)	OFF	Warming up
Blink (2 times consecutively)	OFF	Double Feed Skip mode

*1 Check the status of the scanner using User Utility.

Turning on the Scanner Power

1. Set the power switch (①) of the scanner to "I" (ON).

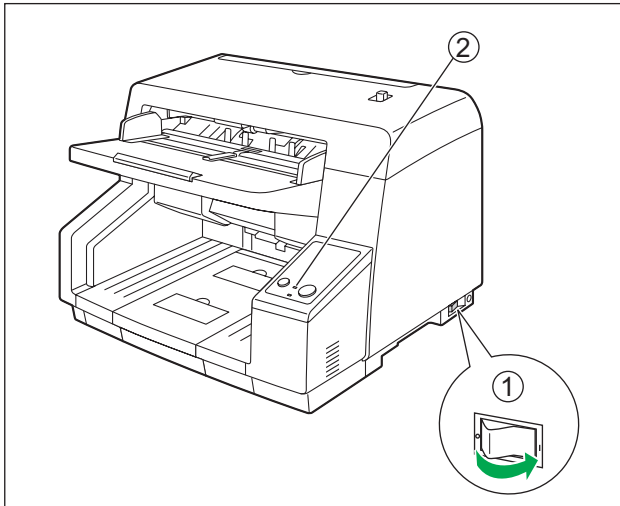

- The ready indicator (②) lights green.

Preparing Documents

Acceptable Documents

The acceptable documents for this scanner are as follows.

Document size

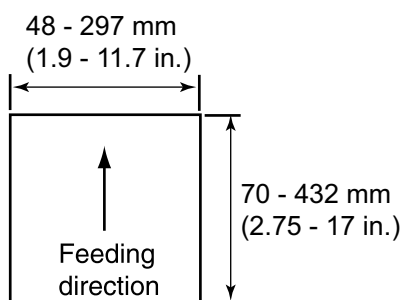

Paper thickness: 20 – 157 g/m² (5 – 42 lbs.)

- You can place up to 200 sheets of fresh, 75 g/m² (20 lbs.) paper on the hopper at one time.

Note

- When you set a document, make sure that its height does not exceed the limit mark on the document guides.

Recommended paper: Plain paper

Document types

<ul style="list-style-type: none"> Plain paper Bond paper Newspaper Carbonless copy paper 	<ul style="list-style-type: none"> Recycled paper OCR paper Bank checks Tracing paper
---	---

Documents must also meet the following conditions

Curl	<p>Less than 10 mm (0.4 in.)</p> <p>Feeding direction</p>
Folding	<p>Less than 10 mm (0.4 in.)</p> <p>Feeding direction</p>

For documents with mixed page sizes and thicknesses

Document thickness	The ratio of page thickness between the thickest and thinnest pages must be less than 1.5.
Document size	The ratio of width and height between the largest page and smallest page must be less than 1.5. Example: If the smallest page is A4 size, then the largest page can be up to A3 size, and if the smallest page is A6, then the largest can be A5.

Unacceptable Documents

The following types of documents may not scan properly:

- Torn or frayed documents
- Curled, wrinkled or folded documents
- Carbon paper
- Thick or irregular documents such as envelopes, documents that are glued together, etc.
- Perforated or punched paper
- Coated paper

Do not scan the following types of paper:

- Thermal paper
- Photographs
- OHP sheets, other plastic films, cloths, or metallic sheets
- Paper with irregularities such as paper clips, staples, paste, or glue
- Document with wet ink or cinnabar seal ink
- Non-rectangular or irregularly shaped paper

Notes about documents for scanning

- Depending on the paper type, scanning results may be poor when you scan unacceptable documents, or even documents that should be acceptable.
If scanned images are skewed, paper jams occur, or double feeding occurs, try scanning again after doing the following:
 - Clean the rollers and sensors.
 - Reduce the number of sheets of paper loaded on the hopper.
 - Change the orientation of documents placed in portrait orientation to landscape orientation, or vice versa.
 - In the scan settings, set "Feeding Speed" to [Slow].^{*1}
 - Scan the documents using manual scanning.
- When using stapled document detection, completely flatten any curling or creases on the rear end of the document, and then perform scanning.

^{*1} For details about configuring the scan settings, refer to the ICP or PIE help.

Scanning Documents

This scanner can scan documents whose pages are all the same size and documents whose pages are different sizes.

Notice

- Make sure to remove paper clips and staples from documents before scanning. Failing to do so can damage the unit, document, or both.

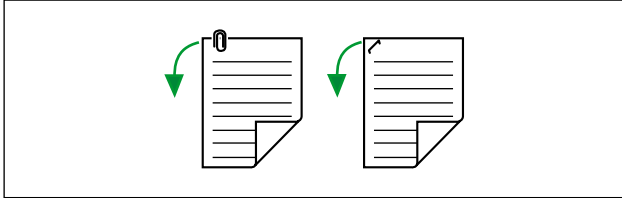

- Curled documents may cause a paper jam or damaging the document, therefore, set the document flat before scanning.
- When scanning important documents, confirm that the number of scanned images matches the number of pages in the document.
- Remove documents from the exit tray after they have been scanned.

Scanning Documents with Pages of the Same Size

1. Use the manual feed selector to select continuous scanning (Auto) or manual scanning (Manual).

Continuous scanning (Auto)

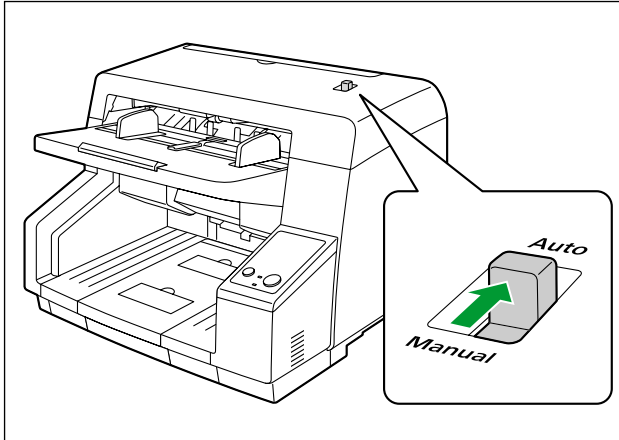

Manual scanning (Manual)

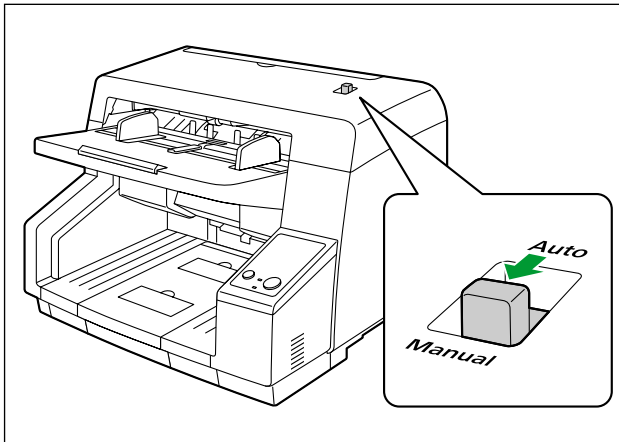

Notice

- When scanning a document manually (Manual), feed the document 1 page at a time.
- When scanning important documents or bound documents, feed them manually.

Note

- When scanning a document manually (Manual), the double feed detection function is disabled.

2. Adjust the document guides (①) slightly larger than the actual size of the documents.

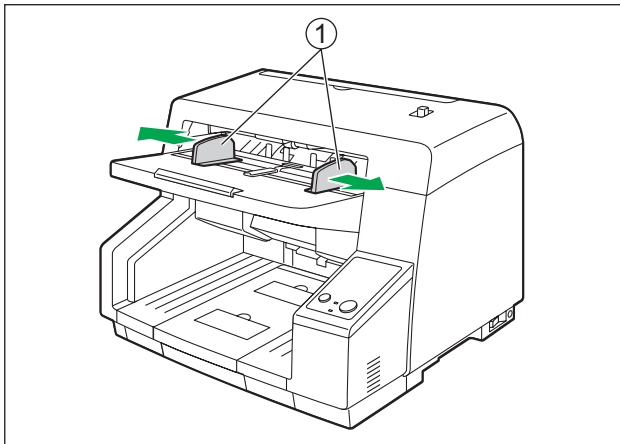

3. Fan the documents.
- Documents that have been stapled together or stacked together (as in a file folder) will need to be separated.
- ① Fan the stack of documents to separate all the edges.
 - ② Hold both ends and bend the documents as shown in the illustration.
 - ③ To flatten the documents, hold firmly and pull them apart as shown in the illustration.

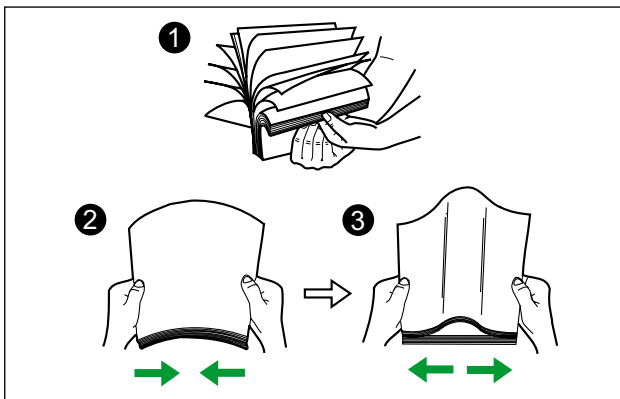

Repeat these steps as necessary.

4. Carefully align the documents.

5. Place the documents on the hopper (①) with the side to be scanned facing up. Then push the documents in the direction of the arrow until they stop.

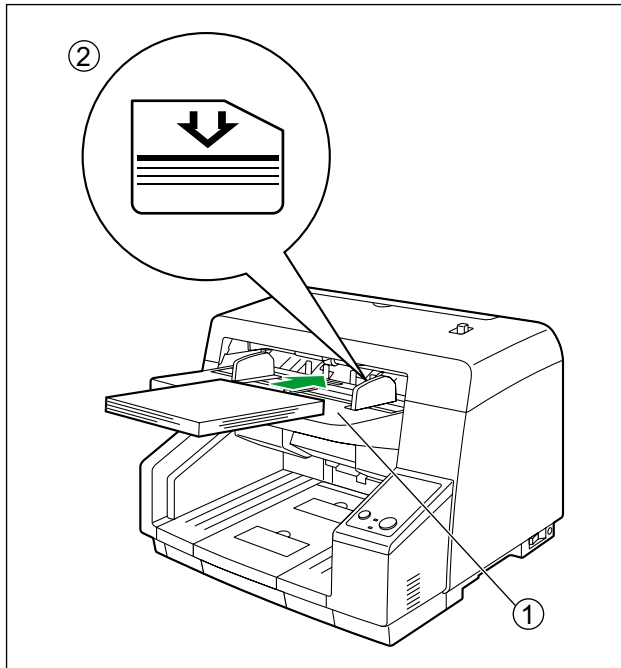

Notice

- The height of the documents should not exceed the limit mark (②) on the document guide. This may cause a paper jam or skewing.

Operation

- Slide the document guides (①) to match the width of the document to be scanned.

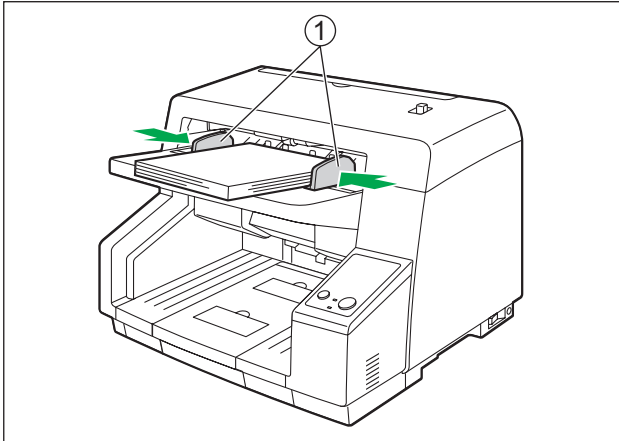

When scanning long sheets of paper

Pull out the hopper extension tray (②) from the hopper.

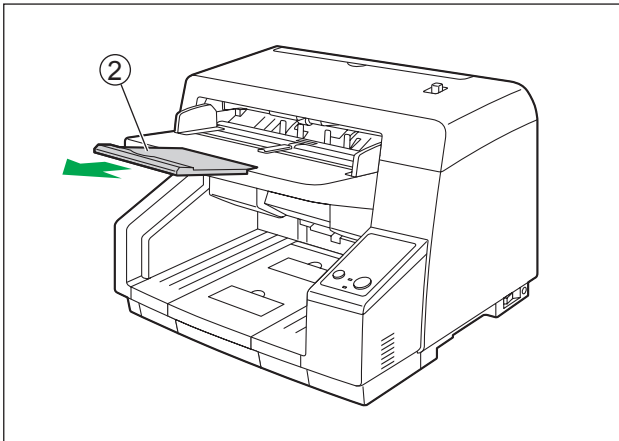

7. Raise the exit stopper (①).

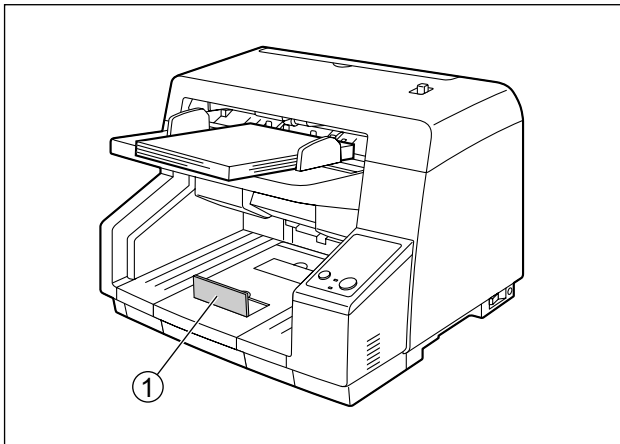

When scanning long sheets of paper

Adjust the exit stopper (②) and extension sub tray (③) to match the size of the document.

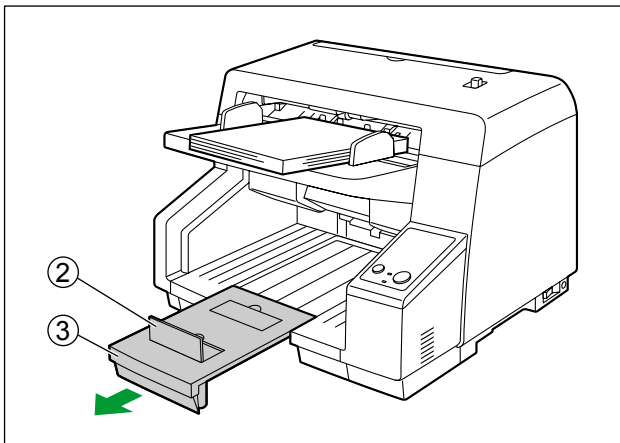

When scanning short sheets of paper

When scanning documents like the one shown in the figure below, fully raise the exit stopper (④), and adjust the extension sub tray (⑤) to match the size of the document.

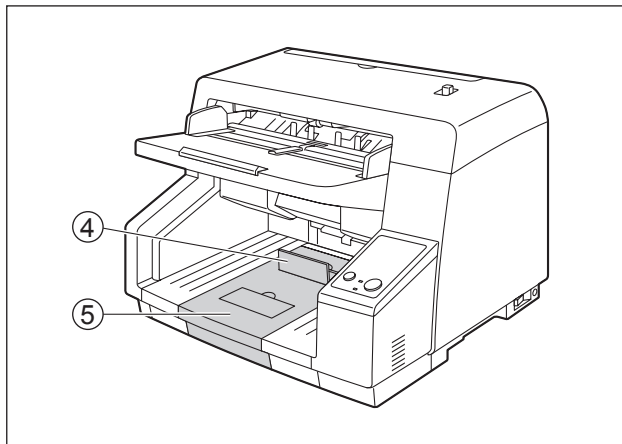
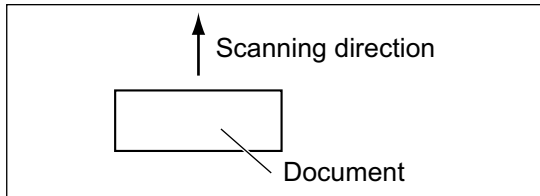

When scanning narrow documents (widths from 48 to 105 mm [1.89 to 4.13 in.]

Lower the exit sub guide (⑥).

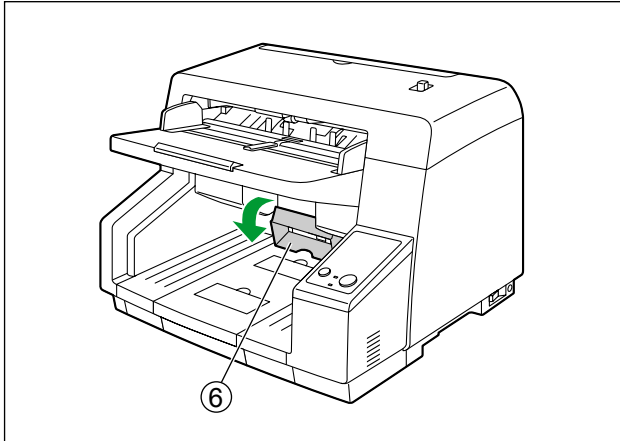
**Notice**

- When you have finished using the exit sub guide, return it to its original position.

8. Open your scanning application^{*1} and scan the documents.

^{*1} The software ICP and QuickScan Pro demo, included with the scanner, can be used for scanning the documents.

Scanning Documents with Pages of Different Sizes

For conditions when scanning documents with mixed page sizes, see "For documents with mixed page sizes and thicknesses" (page 20).

- When scanning different size documents, scanned sheets may need to be reordered for optimum performance.
1. Use the manual feed selector to select continuous scanning (Auto).

Continuous scanning (Auto)

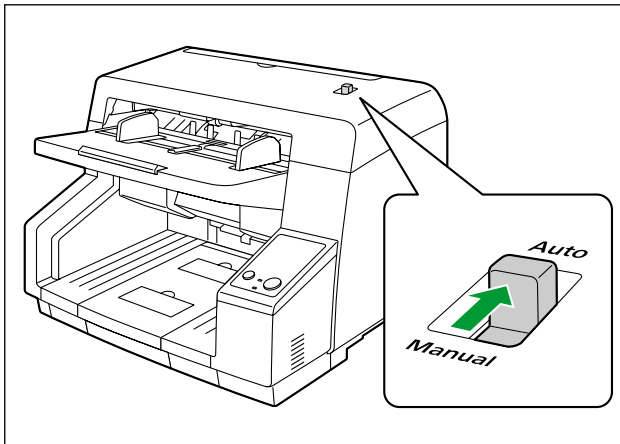

2. Unlock the document guides.

- Slide the document guides selector in the direction shown in the illustration until the ◀ (①) and ● (②) marks are aligned to unlock the document guides.

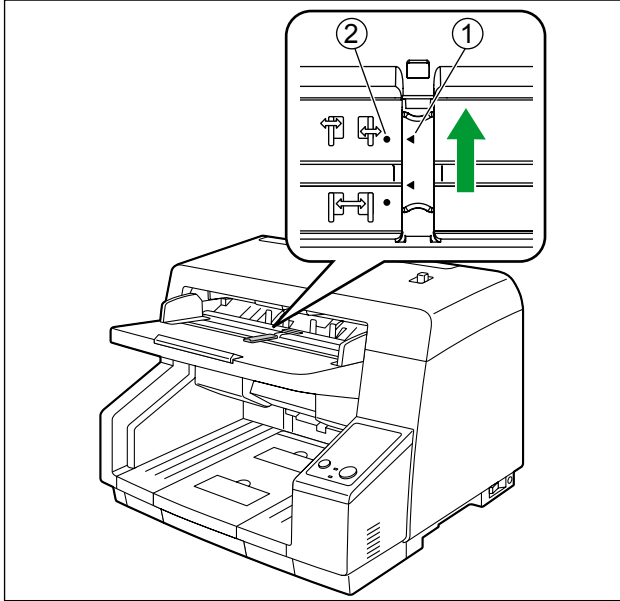

3. Completely spread apart the document guides (①).

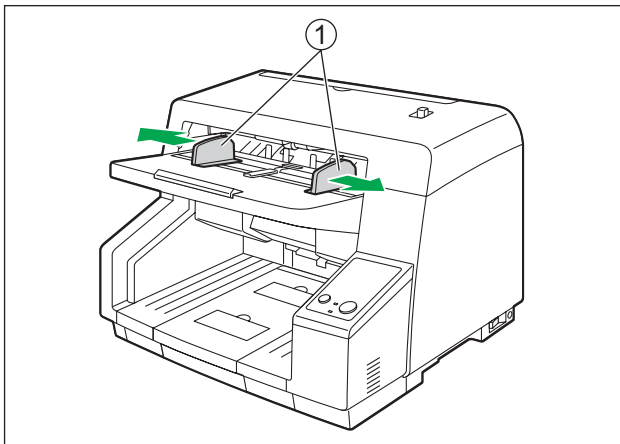

Operation

4. Fan the documents.

- Documents that have been stapled together or stacked together (as in a file folder) will need to be separated.
- ❶ Fan the stack of documents to separate all the edges.
 - ❷ Hold both ends and bend the documents as shown in the illustration.
 - ❸ To flatten the documents, hold firmly and pull them apart as shown in the illustration.

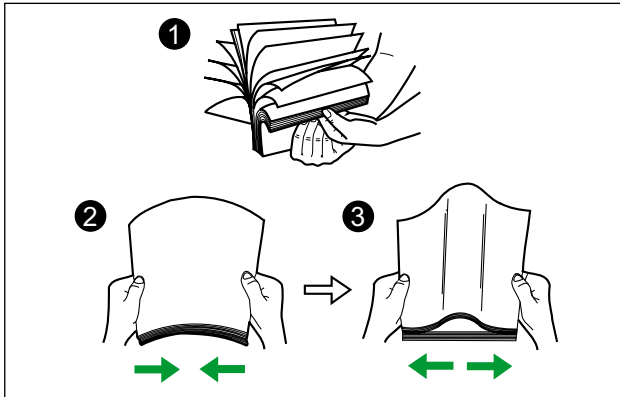

Repeat these steps as necessary.

Notice

- Fan the pages for each page size separately.

5. Align the document pages along one side.

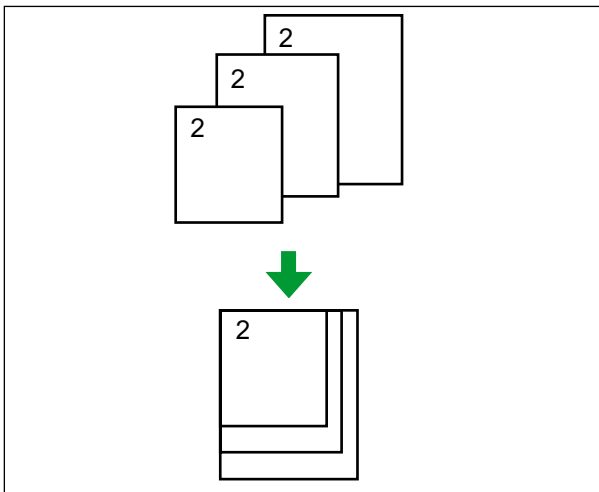

6. Place the documents on the hopper (①) with the scanning side facing up.
 - Align the document position so that the center of the smallest sheet will be fed to the center of the paper feed roller (②). If the document is not properly aligned, the pages will not be fed correctly.

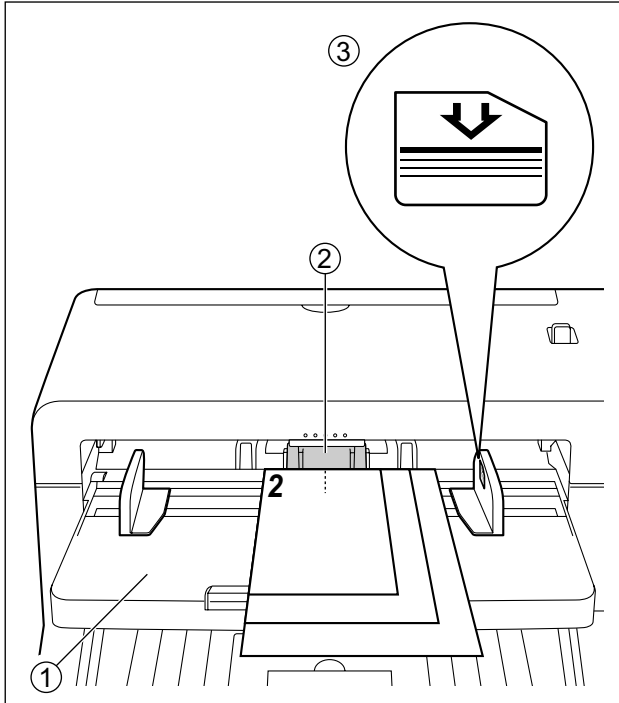

Notice

- The height of the documents should not exceed the limit mark (③) on the document guide. This may cause a paper jam or skew.
- Depending on the types of paper, the document may not be fed smoothly. In such case, reduce the number of sheets of the document.

When scanning long sheets of paper

Pull out the hopper extension tray (④) from the hopper.

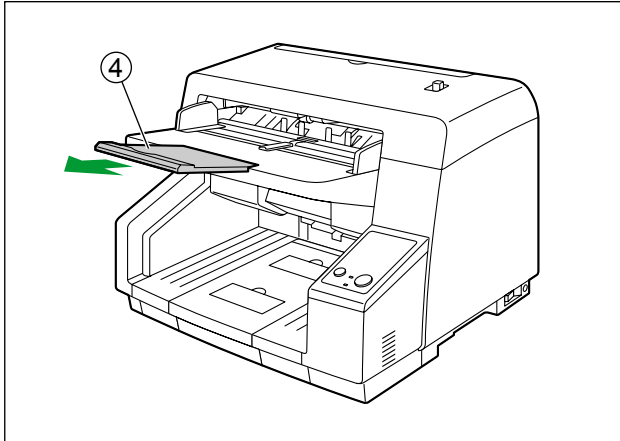

7. Adjust the document guides (①) to the width of the document.

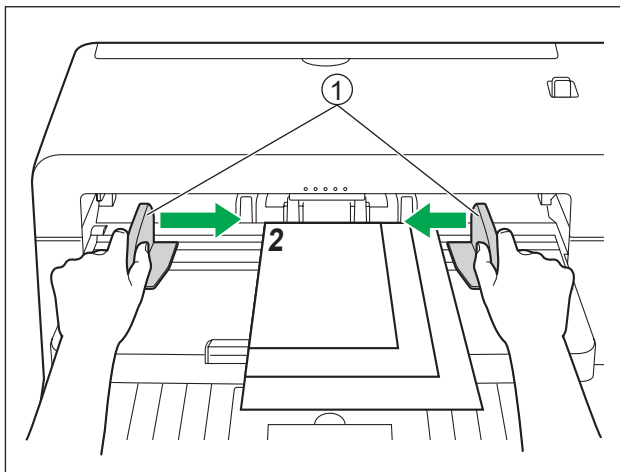

8. Remove the document and lock the document guides.
 - Slide the document guides selector in the direction shown in the illustration until the ◀ (①) and ● (②) marks are aligned to lock the document guides.

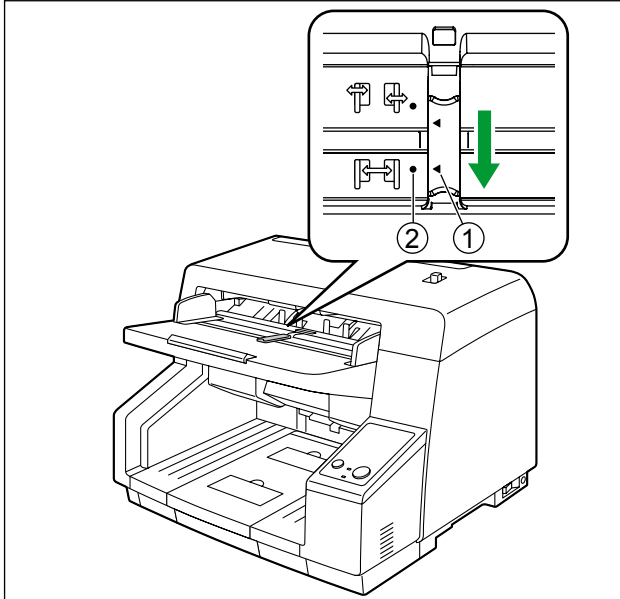

9. Place the document on the hopper again and adjust the document guide according to the size of the document to be scanned.

Notice

- Make sure to align the document pages along one side.
- Make sure that the center of the smallest sheet of the document will be fed to the center of the paper slot.

10. Raise the exit stopper (①).

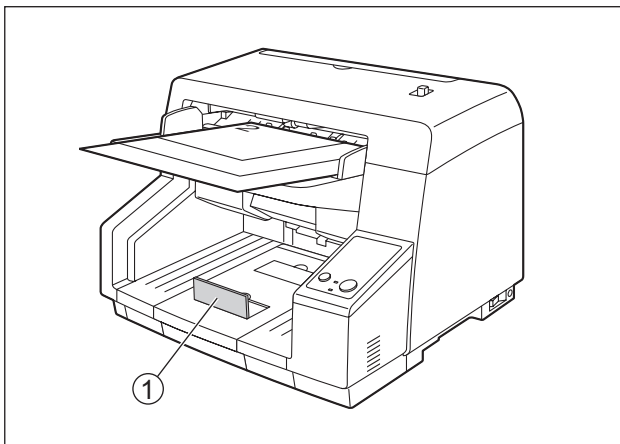

When scanning long sheets of paper

Adjust the exit stopper (②) and extension sub tray (③) to match the largest document page.

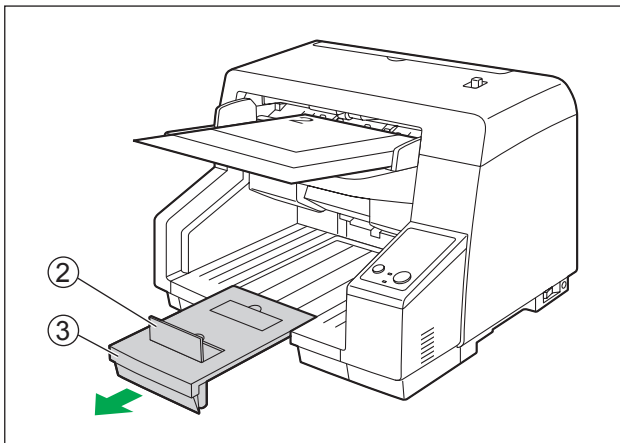

When scanning short sheets of paper

When scanning documents like the one shown in the figure below, fully raise the exit stopper (④), and adjust the extension sub tray (⑤) to match the size of the document.

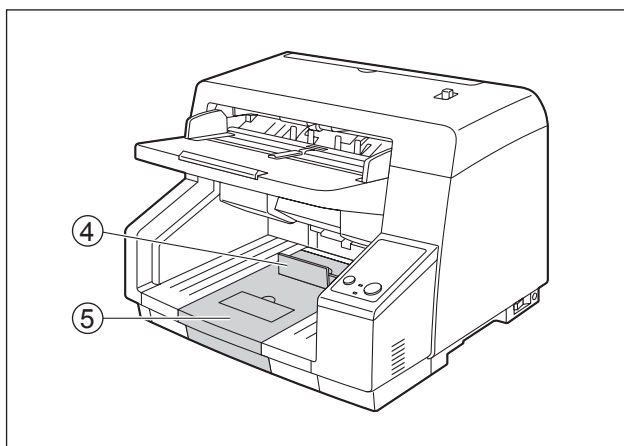
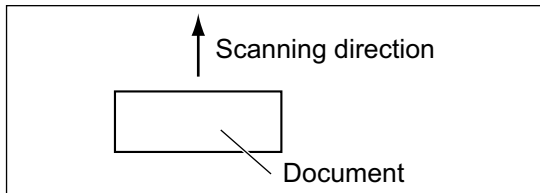
**11. Open your scanning application^{*1} and scan the documents.**

^{*1} The software ICP and QuickScan Pro demo, included with the scanner, can be used for scanning the documents.

Adjusting the left and right document guides to their original position

1. Unlock the document guides.
 - Slide the document guides selector in the direction shown in the illustration until the ◀ (①) and ● (②) marks are aligned to unlock the document guides.

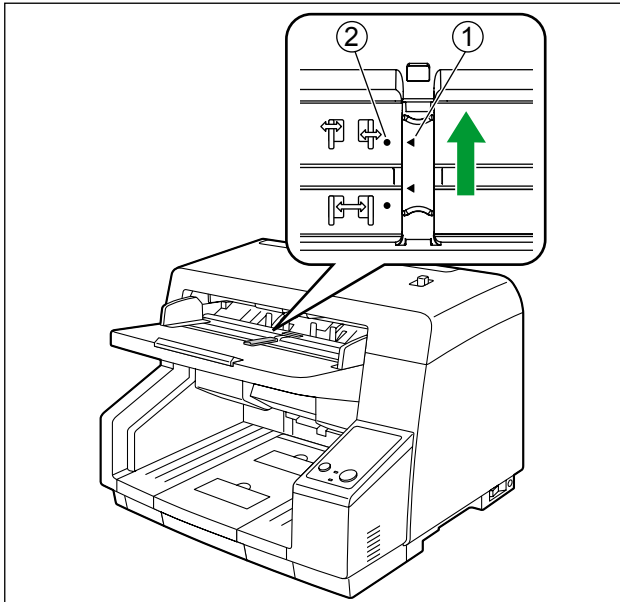

2. Completely spread apart the document guides.

3. Lock the document guides.

- Slide the document guides selector in the direction shown in the illustration until the ◀ (①) and ● (②) marks are aligned to lock the document guides.

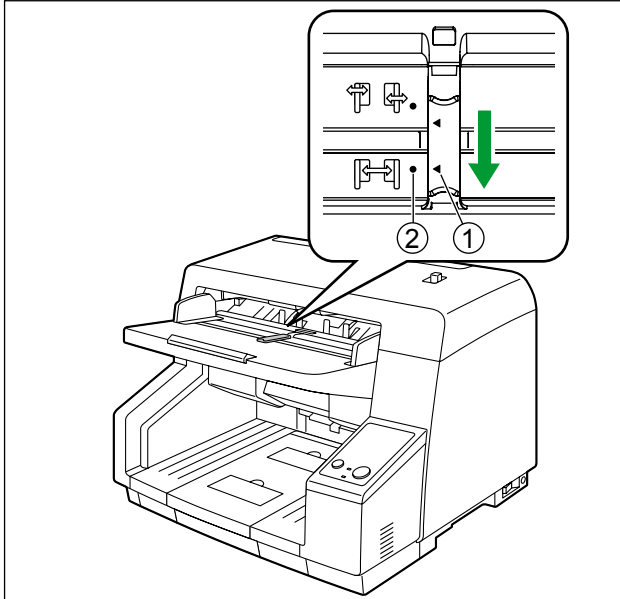

Using Control Sheets

By using control sheets, you can change the scanning conditions in the middle of scanning. Placing a control sheet in the middle of a document lets you change the scanning conditions for all pages scanned after the control sheet.

Control sheets are located on the included CD-ROM.

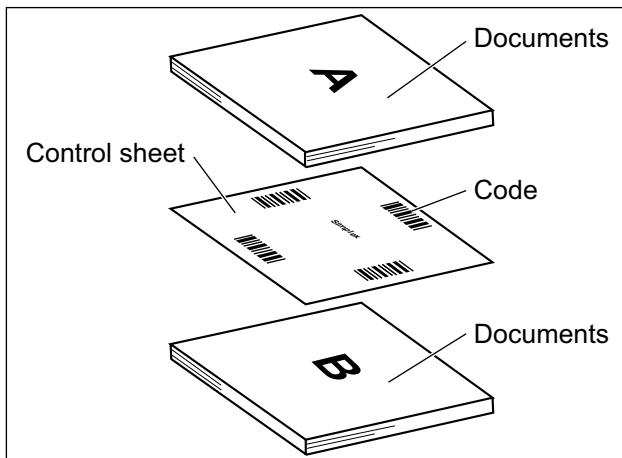

Control sheet functions

Simplex, Duplex, Binary, 256 level gray, Color, Dynamic Threshold, Dither, Error diffusion, Function #1–#9, Separation Sheet

Note

- Multiple control sheets can be used.
- To use control sheet functions, your scanning application must support control sheets. When using control sheets, refer to the instruction manual of your scanning application.
- Print out control sheets from the provided CD-ROM.

About Printing Control Sheets

- Print the control sheet at the specified size; do not enlarge or reduce the size.
- When printing the control sheet, make sure that the pattern is 25 mm (1 in.) from the top of the page and centered horizontally.

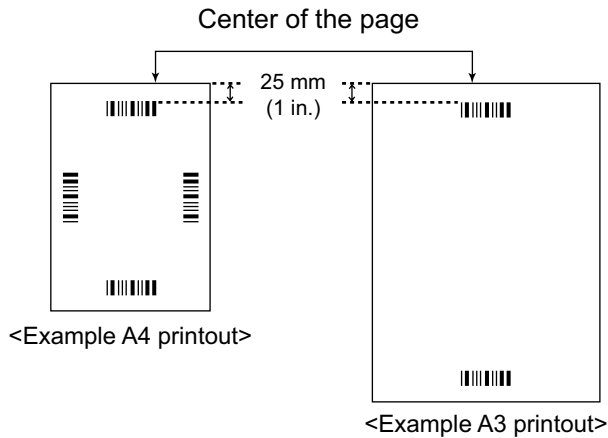

- Use the control sheet that is the same size as the document you are scanning.
- Be careful not to get the control sheet dirty. Do not fold or crease the control sheet. Scanning will not be performed properly.
- For details on control sheet and separation sheet, refer to section "Detect Control Sheet" in the help for PIE.

Printing control sheets

Note

- In order to print control sheets, Adobe® Reader® must be installed on your computer.
- Refer to the instruction manual for your printer for details about changing print settings.

1. Insert the CD-ROM into the CD/DVD driver on your computer.
 - If you have a feature called "Autorun" activated, the installation process will start automatically.
 - The setup window will appear.

Note

- If the AutoPlay dialog box is displayed in Windows Vista or Windows 7, select "CDRun.exe".
- If the program does not start automatically, from [My Computer] ([Computer] in Windows Vista or Windows 7), select the CD/DVD drive, and then double-click "CDRun.exe".

2. Select your scanner.
3. Select [Control Sheet] from the [Manuals] list on the right side of the screen.
4. Print the control sheets at the same size as your document.

Changing the Scan Background Color

By switching the reference plates on the scanner, you can change the scanning background color between black and white. The default setting is black.

Notice

- Set the reference plate (F) and reference plate (B) to the same color. If the front and rear settings are different, then documents will not be scanned correctly.

Switching the Reference Plate

1. Set the power switch (①) of the scanner to "○" (OFF).
 - Remove any documents from the hopper.

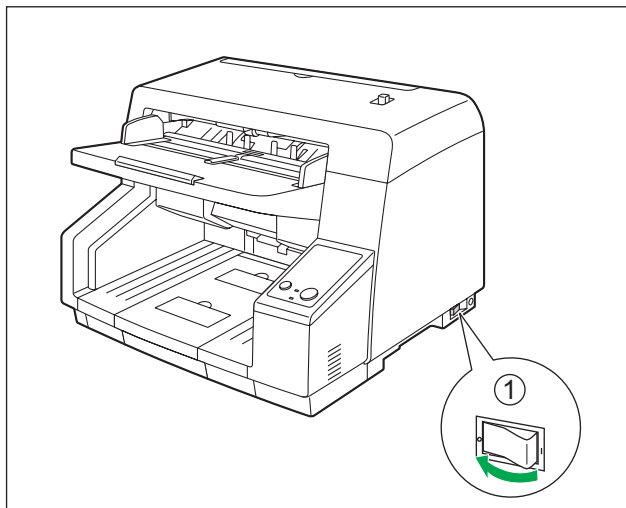

2. Pull the ADF door release (①) towards you, and open the ADF door (②).

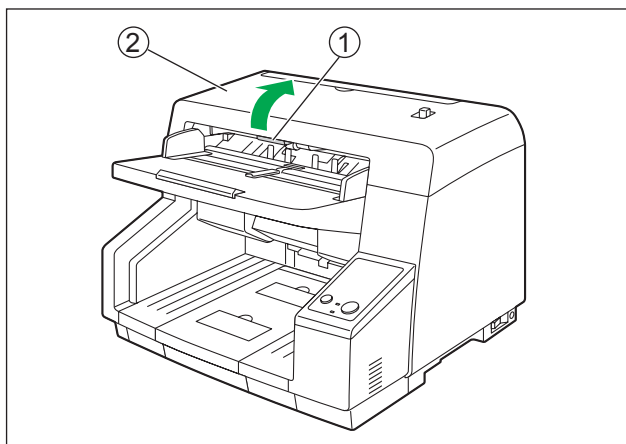

3. Rotate the reference plate (F) (①) and the reference plate (B) (②).
- With both hands, slowly rotate each plate in the direction indicated by the arrow.
 - Rotate each plate until the ◀ mark (③) on the outside of the reference plate and the ▶ mark (④) on the reference plate are aligned.
The color of the reference plate at this time will be the background color.

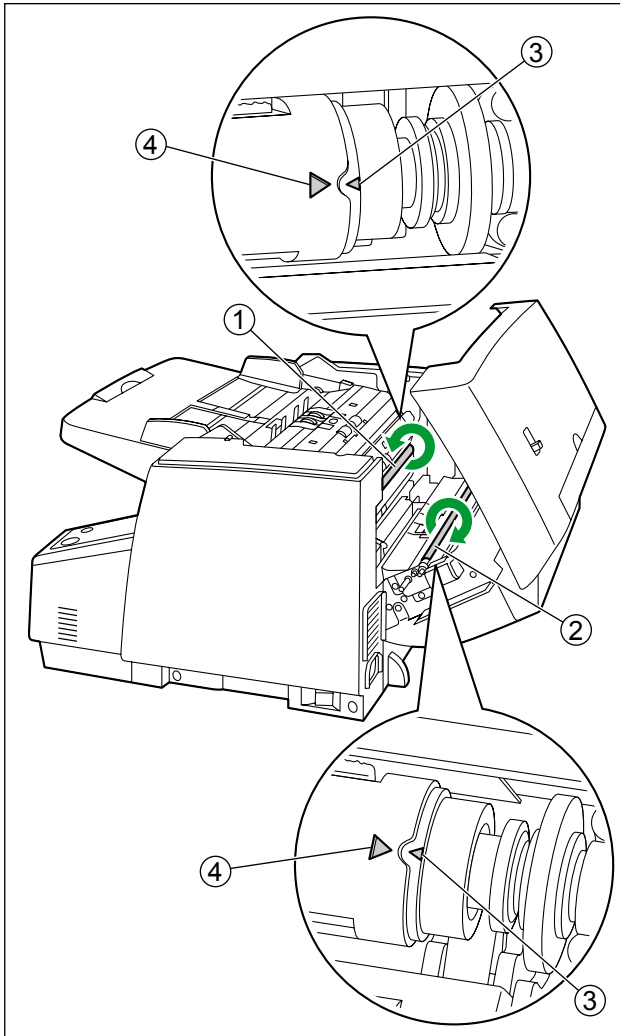

Notice

- Always rotate the reference plates in the directions indicated by the arrows.
- Make sure that the ◀ mark (③) on the outside of the reference plate and the ▶ mark (④) on the reference plate are aligned.
If the marks are not aligned, the background color will not be correct.

4. Close the ADF door.
 - Push both sides of the ADF door down slowly until it clicks into place.

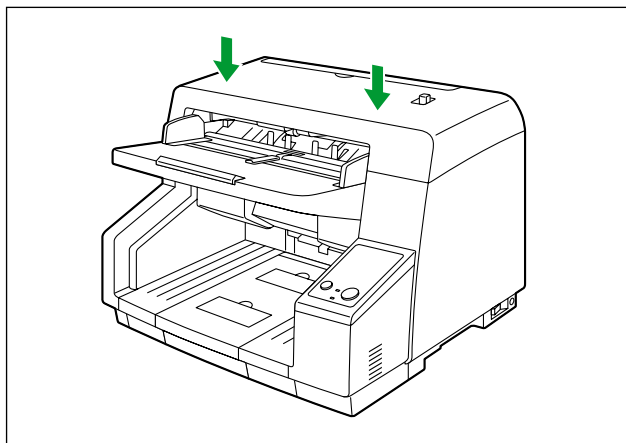

5. Set the power switch of the scanner to "I" (ON).

Clearing Paper Jams

Torn paper, thin paper or paper that is creased on the top edge may cause paper jams. If a paper jam occurs, remove the jammed sheet according to the following procedure.

CAUTION

- The scanning glass may be very hot after scanning a lot of documents. Remove the jammed sheet after the scanning glass's temperature has cooled.

1. Pull the ADF door release (①) towards you, and open the ADF door (②).

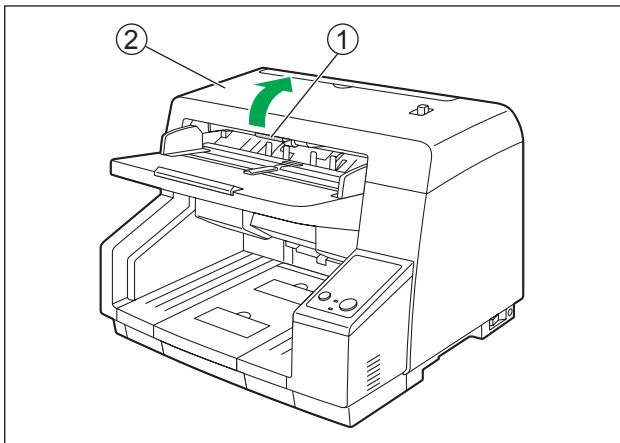

2. Remove the jammed sheet of paper.

When a paper jam occurs inside the scanner:

Remove the jammed sheet of paper from the inside of the ADF door.

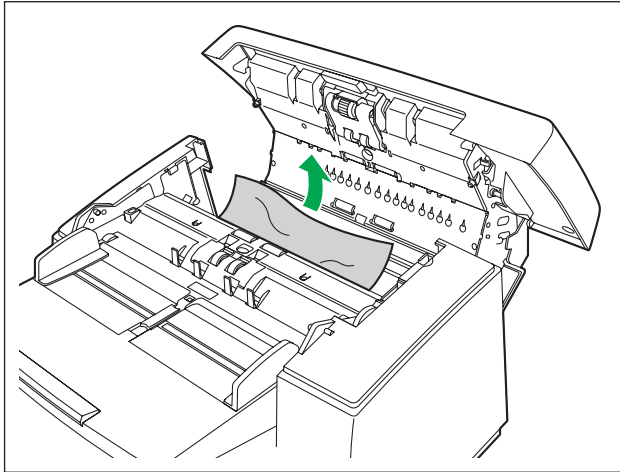

When a paper jam occurs at the exit slot:

Pull the jammed paper from the exit slot (1) towards the front.

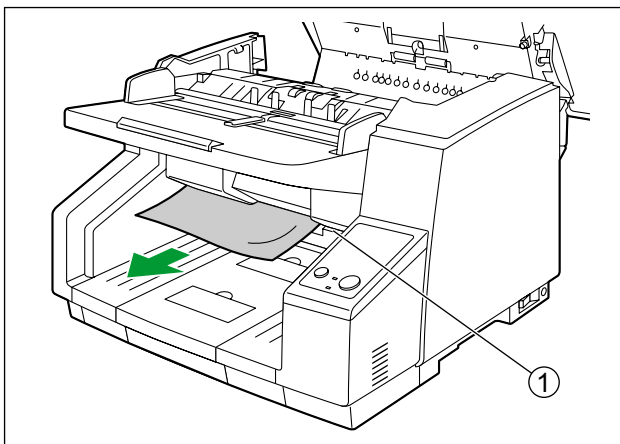

3. Close the ADF door.
 - Push both sides of the ADF door down slowly until it clicks into place.

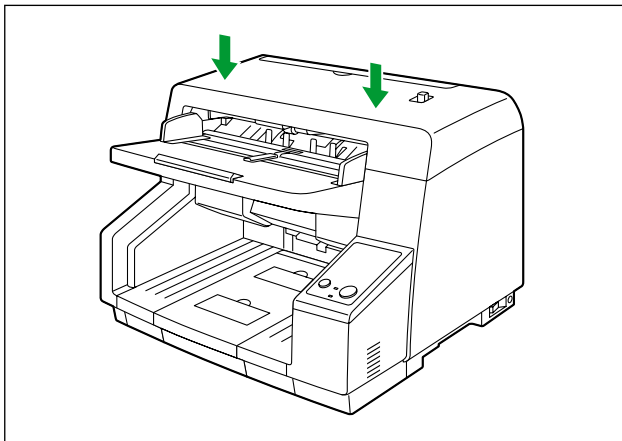

Cleaning the Scanner

Outside of the Scanner

Notice

- Do not use thinner, benzine, or cleaners containing abrasives or surfactants, for cleaning the outside of the scanner.
- Clean the scanner at least once a month.

1. Set the power switch (①) of the scanner to "○" (OFF).

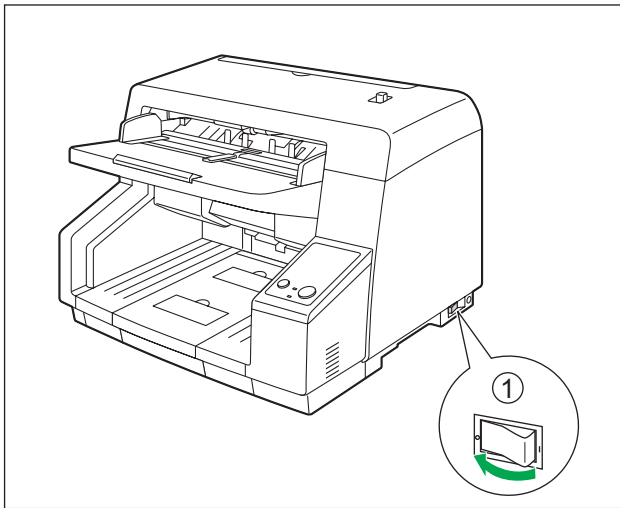

2. Clean the cover with a soft cloth.
 - The document feeder (①) and exit slot (②) get dirty easily. Make sure to clean them.

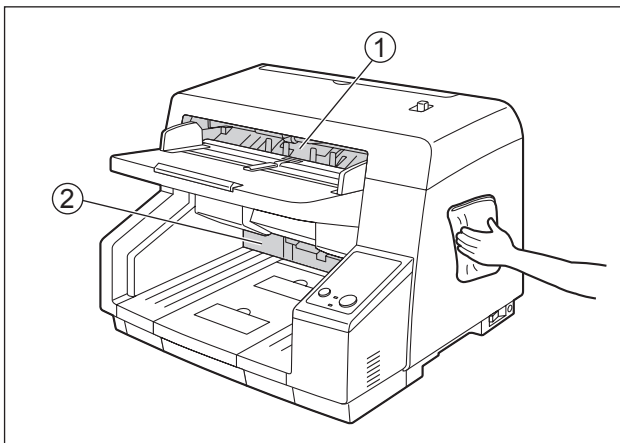

3. Remove dirt and dust from the fan exhaust vent (①) with a brush.

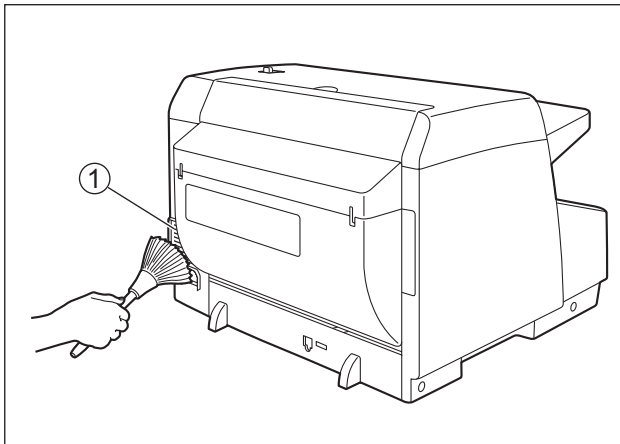

Inside of the Scanner

Note

- Clean the scanner at least once a week or when 20,000 sheets have been scanned, whichever comes first.
- Clean the rollers and sensors if paper jamming or double feeding occurs frequently.
- If double feed detection does not function properly, clean the double feed detectors.
- Clean the scanning glass when black or white lines appear on the scanned images.
- If the documents you are scanning are dirty, then the scanner parts will also become dirty. To maintain proper scanning, clean the scanner parts frequently.

About the roller cleaning paper

Open the roller cleaning paper on the dotted line (①), and take out the roller cleaning paper.

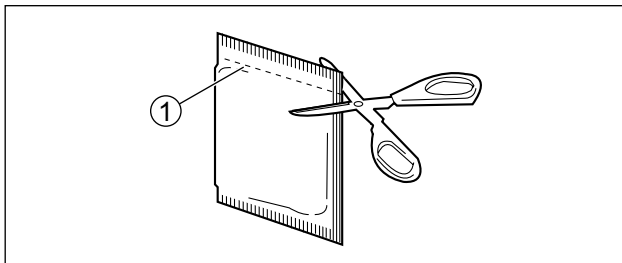

Notice

- Keep the roller cleaning paper out of reach of small children.
- Do not store the roller cleaning paper in direct sunlight or in a place with temperature over 40 °C (104 °F).
- Only use the roller cleaning paper to clean the rollers and scanning glass.
- For details about the roller cleaning paper, please refer to the Material Safety Data Sheet (MSDS). Please ask your Panasonic sales company about obtaining the Material Safety Data Sheet.

Note

- If the bag is left opened for a long period of time before using it, the alcohol will evaporate. Please use the roller cleaning paper immediately after opening the bag.
- The roller cleaning paper (KV-SS03) is available from the dealer where you purchased the scanner. For supplies and accessories:
Call 1-800-726-2797 (U.S.A. only) or your dealer.

How to use the blower

Remove the brush tip from the blower (①), place it on the area that you want to clean (②), and then blow away any dirt, as shown in the following figure.

- If dirt has accumulated, first remove the dirt with the brush tip of the blower, and then remove the brush tip and blow away the remaining dirt.

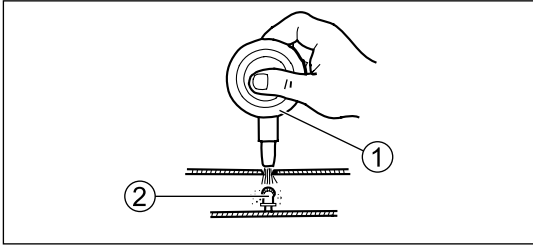

Cleaning the Conveyor

CAUTION

- The scanning glass may be very hot after scanning a lot of documents. Clean the scanning glass after the temperature has cooled.

Note

- Clean the conveyor before cleaning the rollers.
1. Set the power switch of the scanner to "○" (OFF).
 2. Pull the ADF door release (①) towards you, and open the ADF door (②).

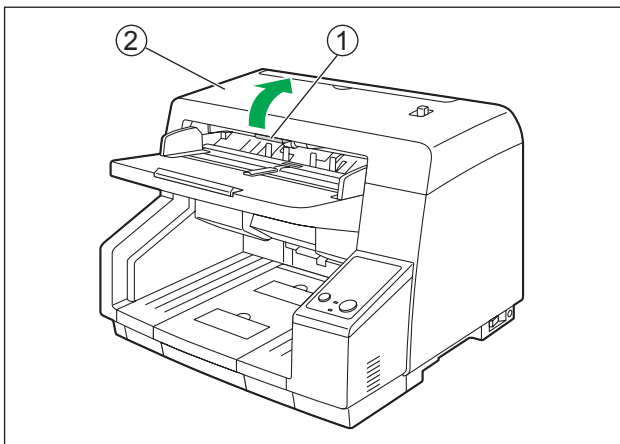

3. With a dry cloth, wipe off any dirt on the conveyor (①).

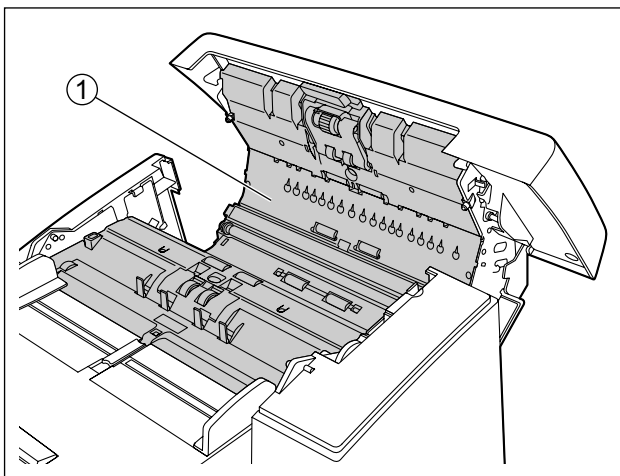

4. With the included blower, blow away any dirt that has accumulated on the self-cleaning brushes (①).
 - Rotate the reference plates (②, ③) in the direction indicated by the arrow so that you can see the brush.

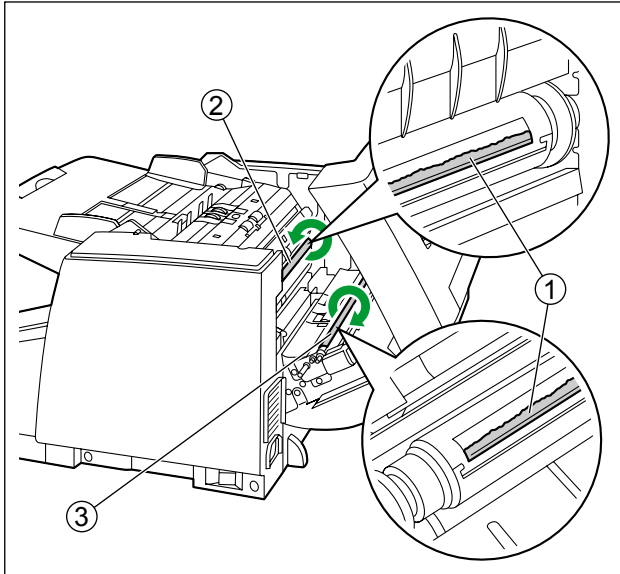

- After cleaning, rotate the reference plates (②, ③) in the directions indicated by the arrows to return the plates to the original background color.

Notice

- After cleaning, make sure that the ◀ mark on the outside of the reference plate and the ▶ mark on the reference plate are aligned (page 44).
If the marks are not aligned, the background color will not be correct.

5. With the included blower, blow away any dirt that has accumulated on the ion outlets (①).

Notice

- When cleaning the ion outlets, be sure to remove the brush tip from the blower. Using the blower with the brush tip still on might damage the ionizer.

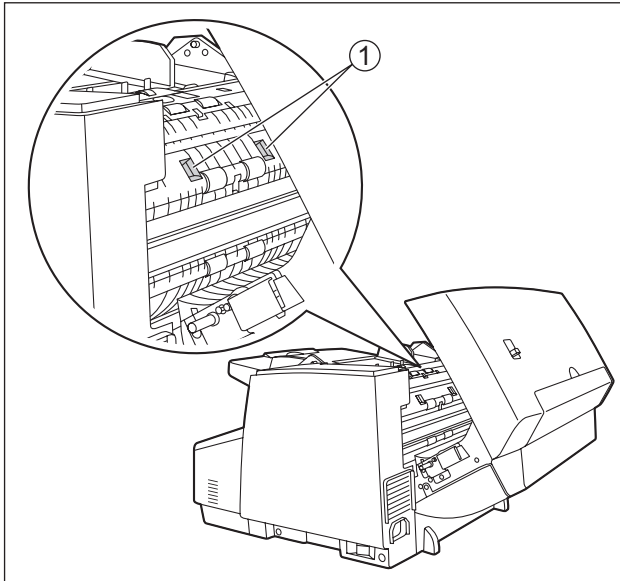

6. Close the ADF door.
 - Push both sides of the ADF door down slowly until it clicks into place.

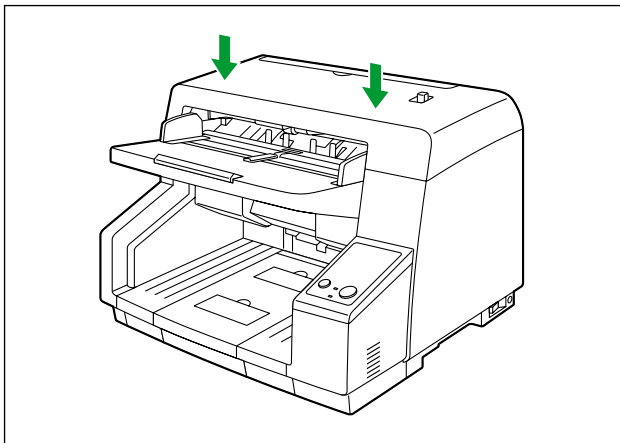

7. Set the power switch of the scanner to "I" (ON).

Cleaning the Rollers

CAUTION

- The scanning glass may be very hot after scanning a lot of documents. Clean the scanning glass after the temperature has cooled.

1. Set the power switch of the scanner to "○" (OFF).
2. Pull the ADF door release (①) towards you, and open the ADF door (②).

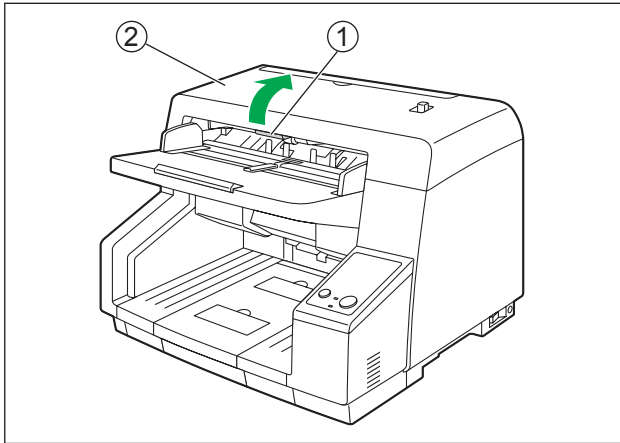

3. Use the roller cleaning paper (page 51) to remove the dirt from the surfaces of all rollers.

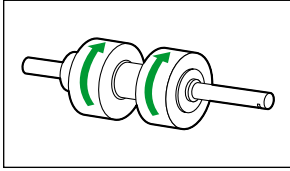
Direction to wipe rollers

Double feed prevention roller, Separation roller

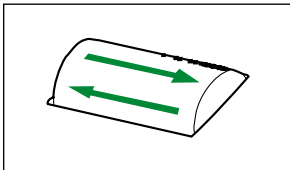

Other rollers

Notice

- After removing the double feed prevention roller, gently wipe dirt from the surface of the roller in the direction indicated by the arrows in the illustration. If you wipe too hard, you may damage or misalign the roller.
For instructions on how to remove the double feed prevention roller, see "Replacing the Double Feed Prevention Roller" (page 69).
- Wipe dirt off of the other rollers in the directions indicated by the arrows in the illustration. Use your finger to rotate the roller and wipe dirt off of the entire surface of the roller. If the roller rotates when wiping it, gently hold it in place with your finger.

Location of Rollers

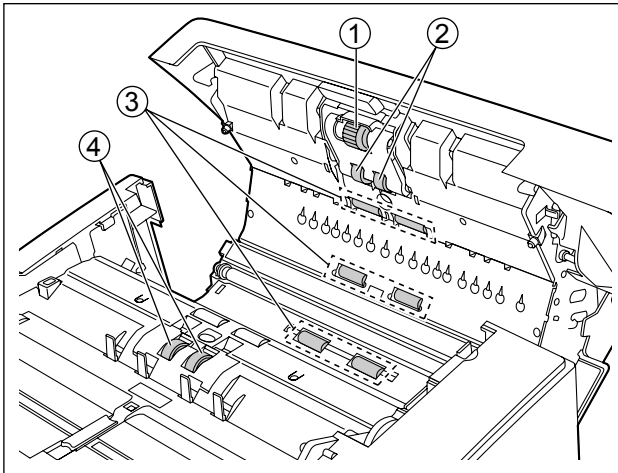

- ① Paper feed roller
- ② Separation roller
- ③ Free rollers
- ④ Double feed prevention roller

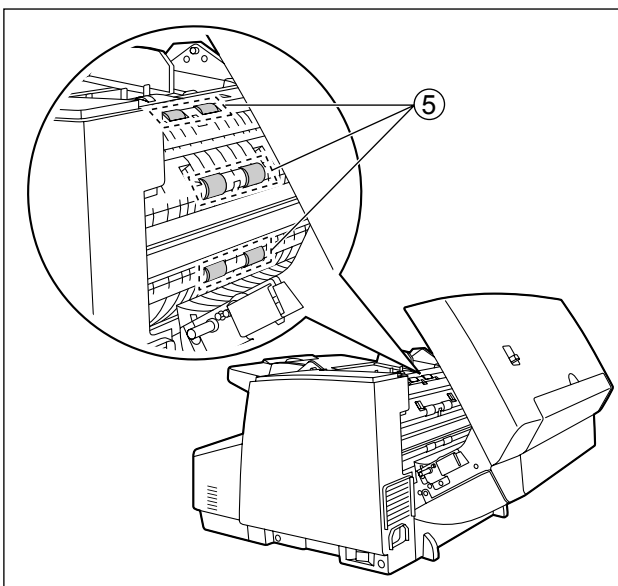

- ⑤ Drive rollers

4. Close the ADF door.
 - Push both sides of the ADF door down slowly until it clicks into place.

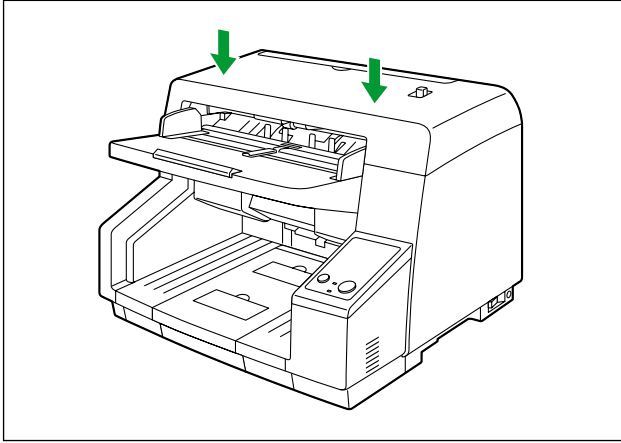

5. Set the power switch of the scanner to "I" (ON).
6. Reset the roller cleaning counter in User Utility to 0.
 - Start User Utility, and in the window, click the [Clear Counter] button for "After Clean Roller" to reset to counter to 0.
 - For details, refer to the help for User Utility.

Cleaning the Sensors and Scanning Glass

CAUTION

- The scanning glass may be very hot after scanning a lot of documents. Clean the scanning glass after the temperature has cooled.

1. Set the power switch of the scanner to "○" (OFF).
2. Pull the ADF door release (①) towards you, and open the ADF door (②).

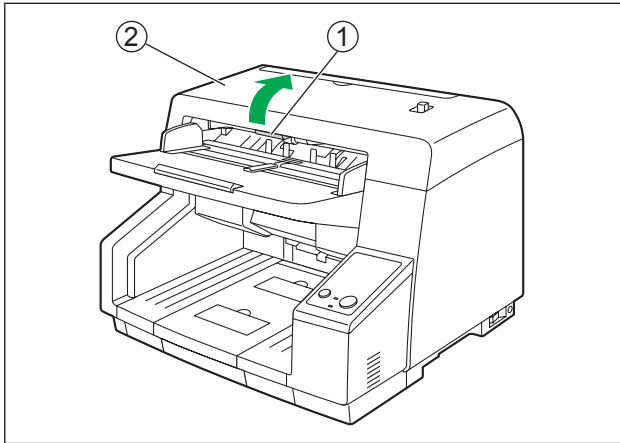

3. Remove dirt on the sensors (①, ②, ③, ④, ⑦) and reflectors (⑩) with the included blower, then wipe the scanning glass (⑤, ⑨) and reference plates (⑥, ⑧) with the roller cleaning paper (page 51).

Location of Sensors

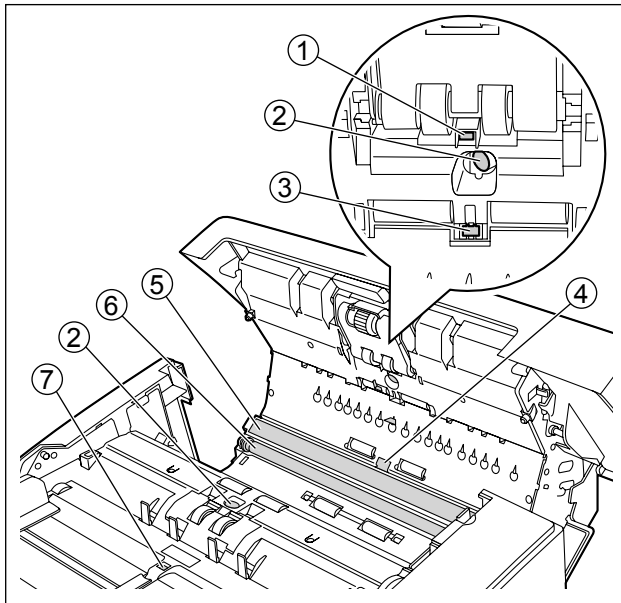

- ① Waiting sensor
- ② Double feed detector
- ③ Slip detect sensor
- ④ Starting sensor
- ⑤ Scanning glass (F)
- ⑥ Reference plate (B)
- ⑦ Paper sensor

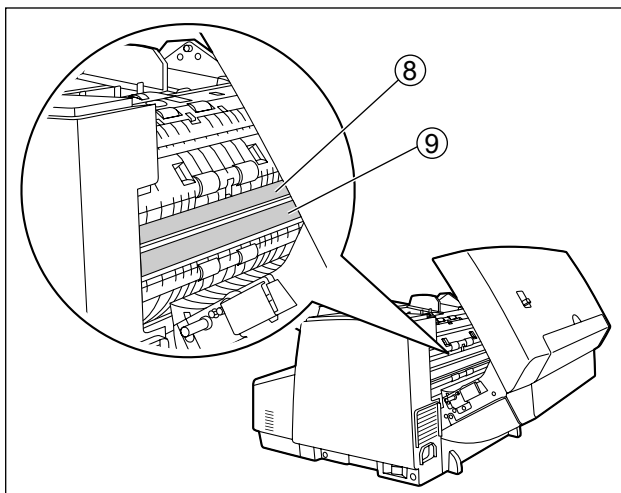

- ⑧ Reference plate (F)
- ⑨ Scanning glass (B)

Notice

- After cleaning, make sure that the ◀ mark on the outside of the reference plate and the ▶ mark on the reference plate are aligned (page 44).
If the marks are not aligned, the background color will not be correct.

Location of Reflectors

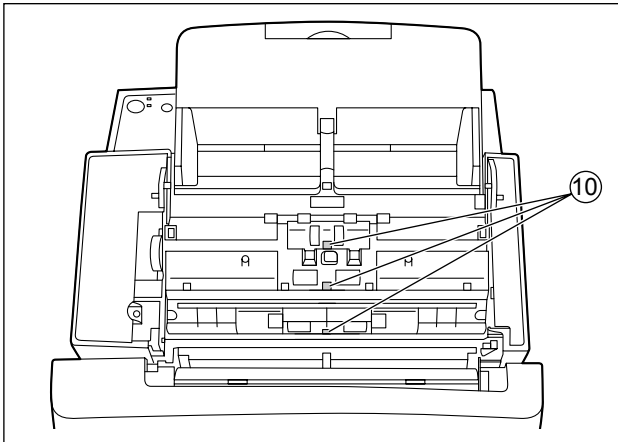

⑩ Reflectors

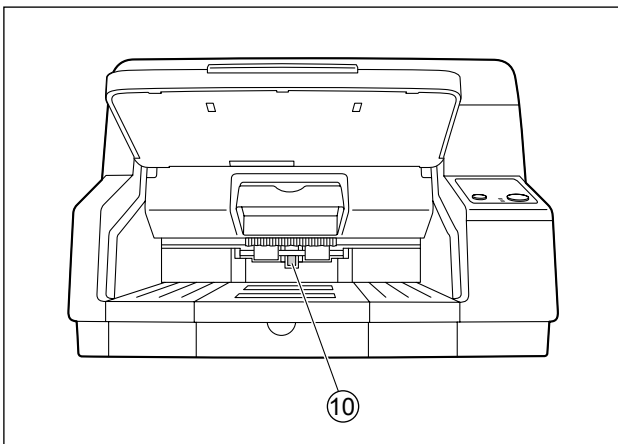

4. Close the ADF door.
 - Push both sides of the ADF door down slowly until it clicks into place.

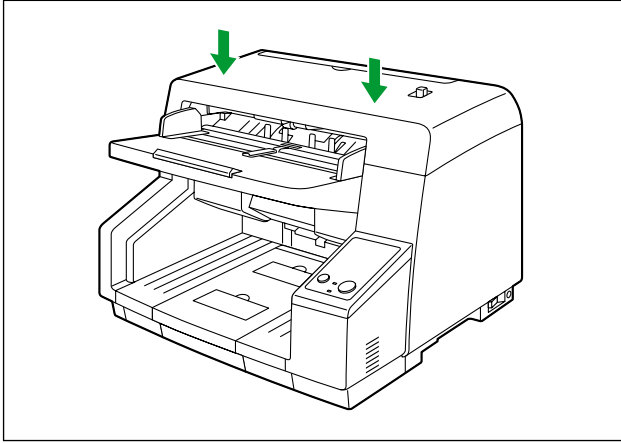

5. Set the power switch of the scanner to "I" (ON).

Replacement Parts and Optional Units

	Part Name	Part Number	Notes
Replacement Parts	Roller exchange kit <ul style="list-style-type: none"> Paper feed roller module Double feed prevention roller 	KV-SS039	–
	Roller cleaning paper	KV-SS03	See "About the roller cleaning paper" (page 51).
	Ink cartridge	KV-SS021	For optional imprinter unit. For instructions on installation and removal, see "Installing the Ink Cartridge" (page 77).
Optional Units	Imprinter unit	KV-SS014	Prints text and numbers on documents. Includes 1 ink cartridge. For instructions on installation, see "Installing the Imprinter Unit" (page 74).

Note

- To purchase separately sold items, contact your dealer.

When to replace parts

We recommend replacing the paper feed roller module and double feed prevention roller after scanning 350,000 sheets of paper. (350,000 sheets is based on scanning normal paper. Depending on the type of paper and other factors, the actual lifetime for the rollers will differ.)

In User Utility, you can check the number of sheets that have been scanned.

Replacing Parts

If double feeding or paper jam occurs frequently even after cleaning the roller (page 56), please call your dealer to order a "Roller exchange kit (KV-SS039)", and replace the paper feed roller module and double feed prevention roller.

Replacing the Paper Feed Roller Module

1. Set the power switch (①) of the scanner to "○" (OFF), and unplug the power cord.

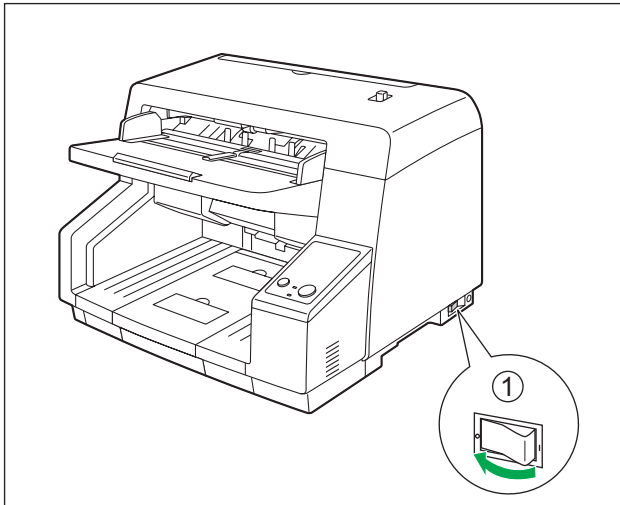

2. Pull the ADF door release (①) towards you, and open the ADF door (②).

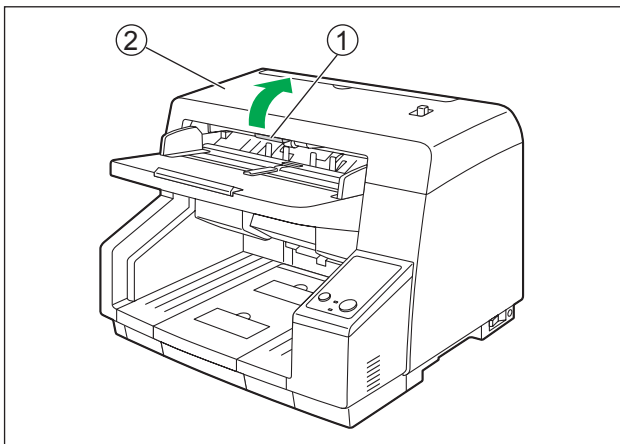

Replacement Parts and Optional Units

3. Move the lever (①) of the paper feed roller module in the order indicated by the arrow (①, ②), and then pull out the module towards you.

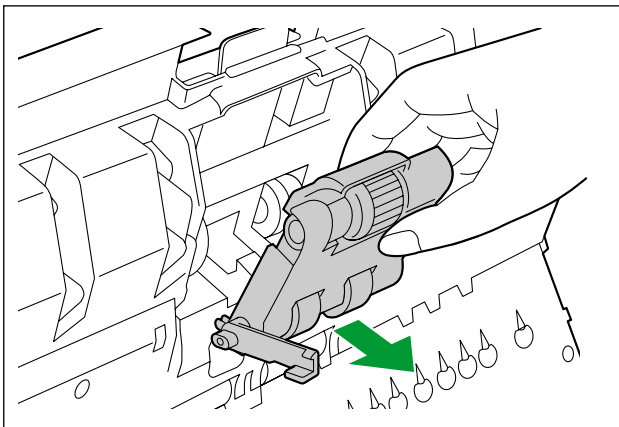
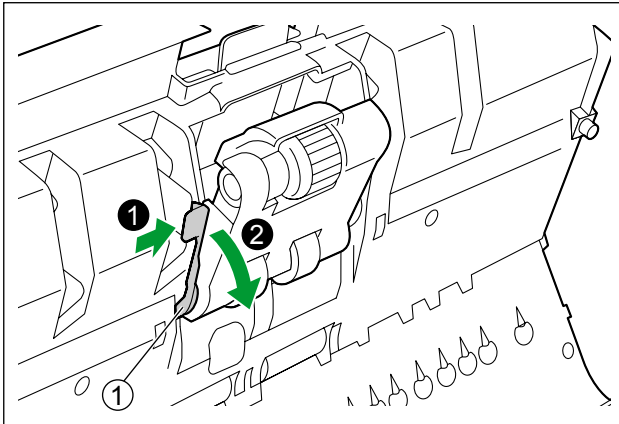

4. Take out the new paper feed roller module in the optional "Roller exchange kit (KV-SS039)".

5. Install the new paper feed roller module.

- With the lever (①) of the paper feed roller module lowered, insert both protrusions (②) into the grooves (③), and then slowly raise the lever in the direction indicated by the arrow until it clicks into place.

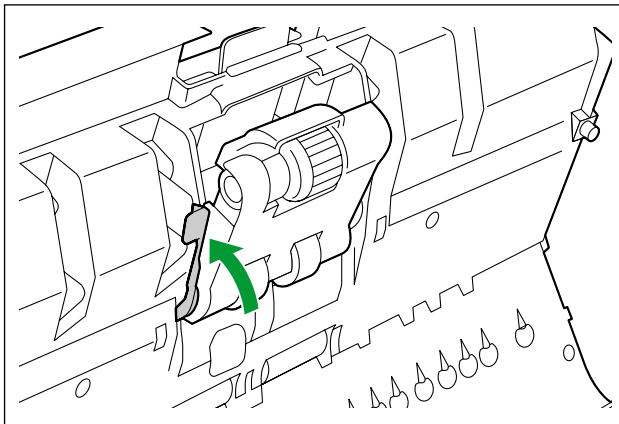
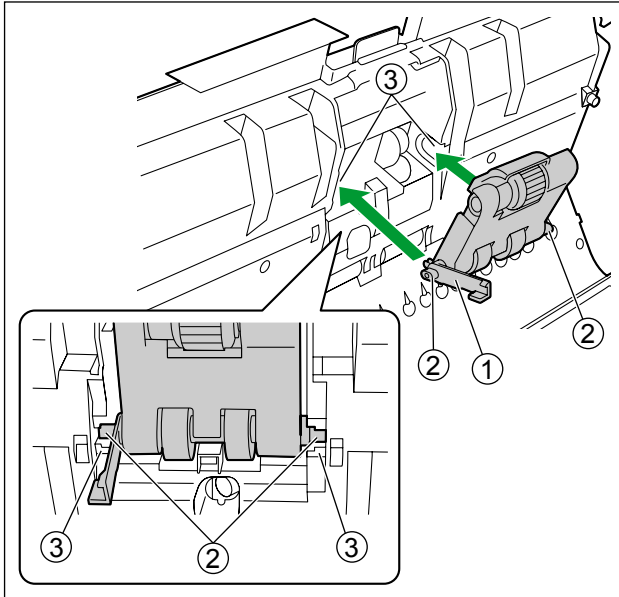

Notice

- Make sure that the paper feed roller module's lever is firmly set. If the lever is not firmly set, the lever or the paper feed roller module might become damaged or might not function correctly.

6. Close the ADF door.
 - Push both sides of the ADF door down slowly until it clicks into place.

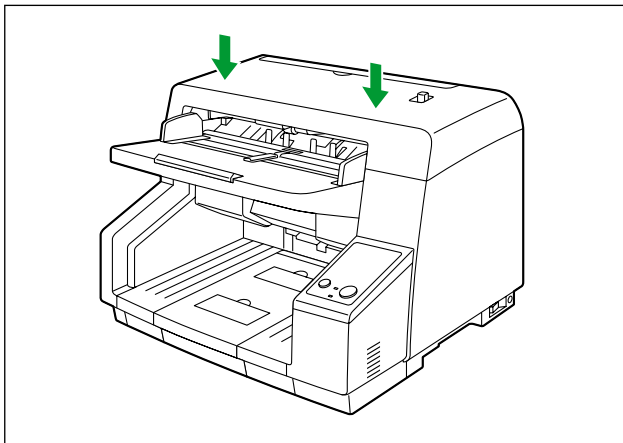

7. Plug in the power cord, and set the power switch of the scanner to "I" (ON).

Replacing the Double Feed Prevention Roller

1. Set the power switch (①) of the scanner to "○" (OFF), and unplug the power cord.

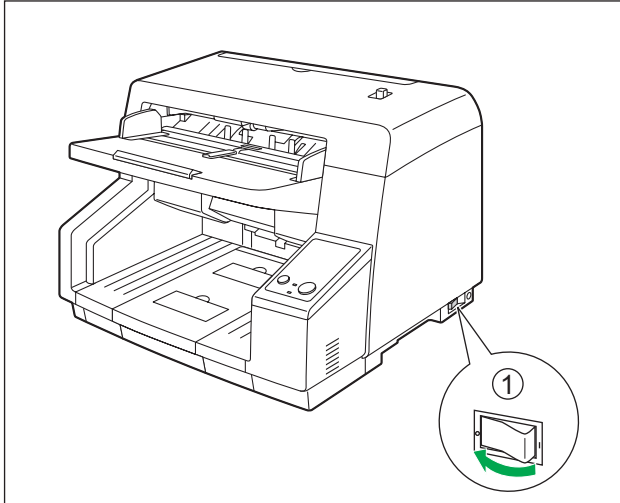

2. Pull the ADF door release (①) towards you, and open the ADF door (②).

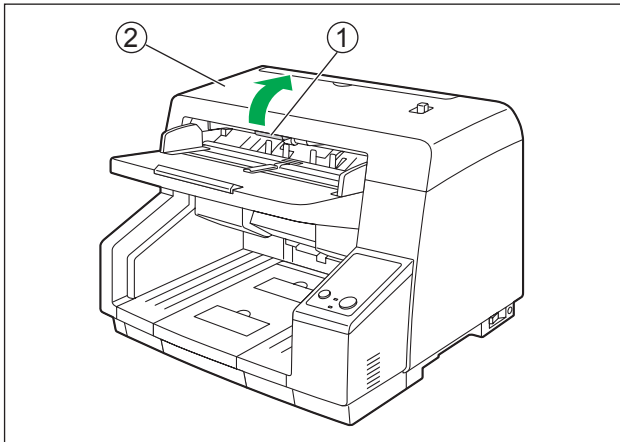

3. Pull towards you and remove the double feed prevention roller cover by using the indent (①).

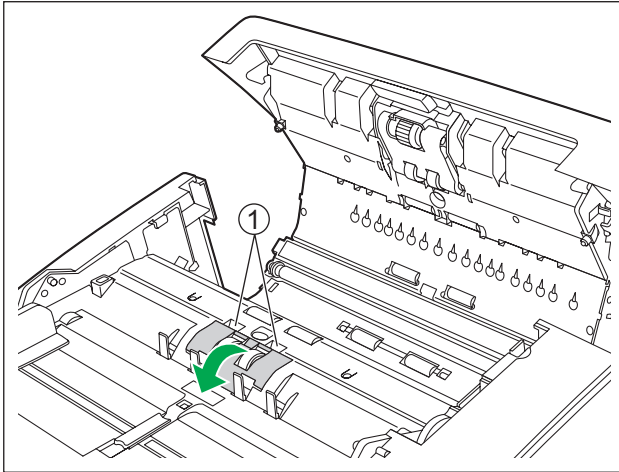

4. While pulling the tab (①) in the direction indicated by the arrow, lift the double feed prevention roller (②) in the direction of the arrow. Then, pull out the right shaft (when facing it) from the notch in the roller mount.

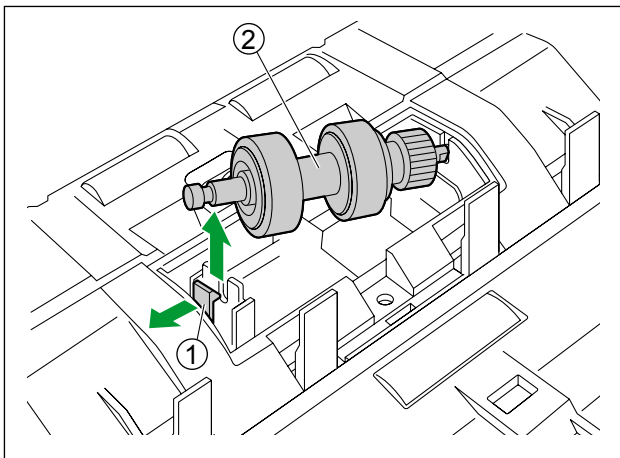

5. Take out the new double feed prevention roller in the optional "Roller exchange kit (KV-SS039)".

6. Install the new double feed prevention roller.

- Align the shaft that is shaped as indicated by ① with the notch in the roller mount (②), and then insert the shaft in the notch. Push the shaft on the opposite side (③) until it clicks into place.

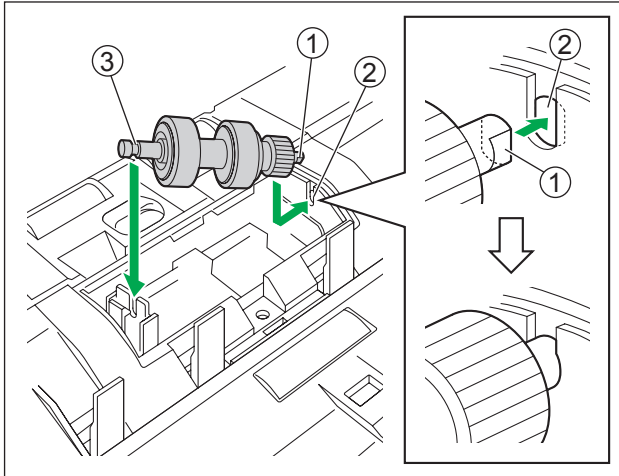

Notice

- After you install the double feed prevention roller, make sure that the shaft is inserted into the tab, and that the shaft will not rotate or move. If the roller is not installed correctly, it may cause double feeding or a paper jam.

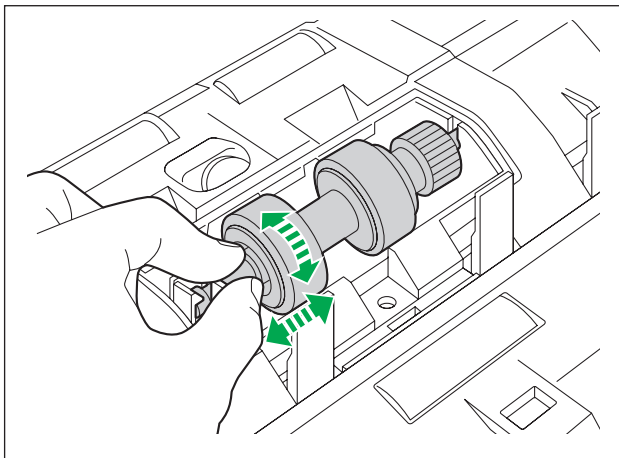

7. Insert the protrusion (①) of the double feed prevention roller cover into the hole on the main unit, and then push in the part of the roller cover indicated by ② in the direction indicated by the arrow until it clicks into place.

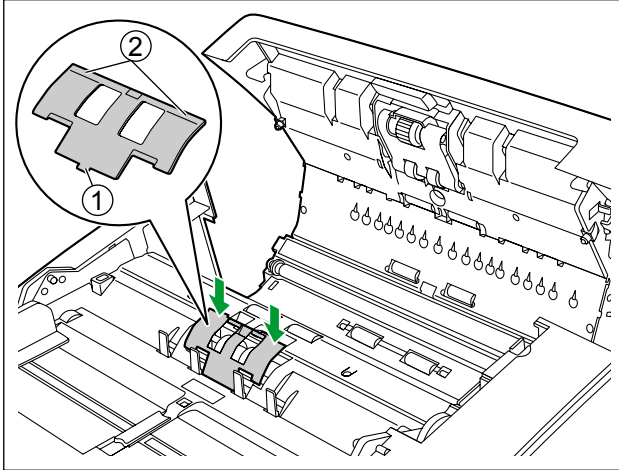

Notice

- Make sure that the double feed prevention roller cover does not stick up.
If the double feed prevention roller cover is closed incompletely, damage or paper jams can occur.

8. Close the ADF door.
 - Push both sides of the ADF door down slowly until it clicks into place.

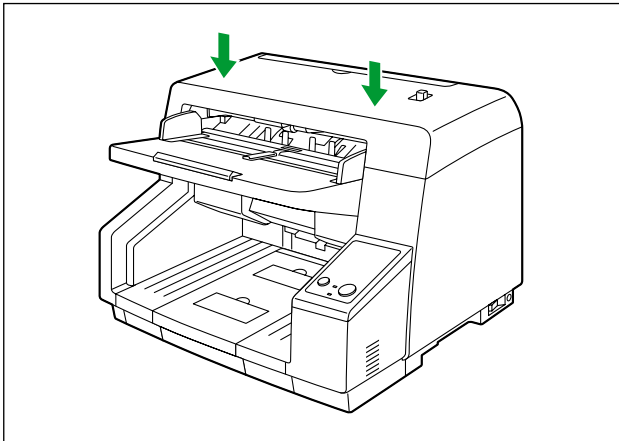

9. Plug in the power cord, and set the power switch of the scanner to "I" (ON).
10. Reset the roller replacing counter in User Utility to 0.
 - Start User Utility, and in the window, click the [Clear Counter] button for "After Replace Roller" to reset the counter to 0.
 - For details, refer to the User Utility help.

Installing Optional Units

Installing the Imprinter Unit

The imprinter prints on the face of the document before scanning. The printed material will also be scanned.

1. Set the power switch (①) of the scanner to "○" (OFF).

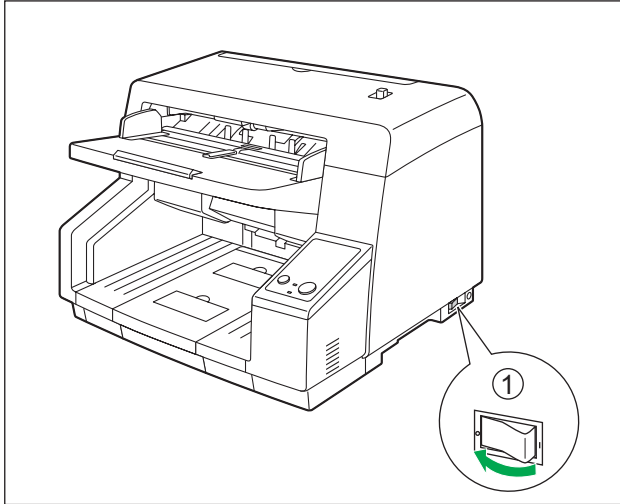

2. Open the imprinter door.

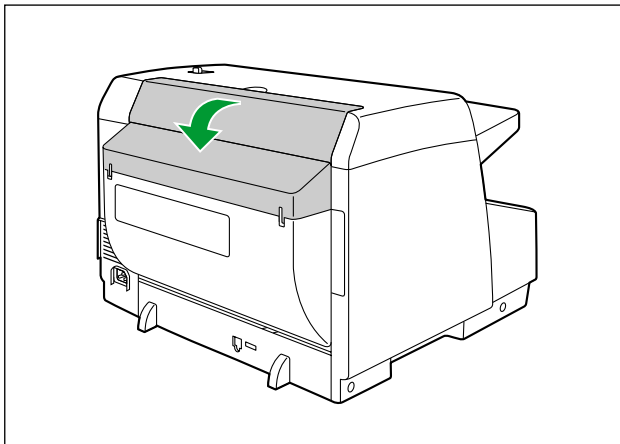

3. Connect the cable.

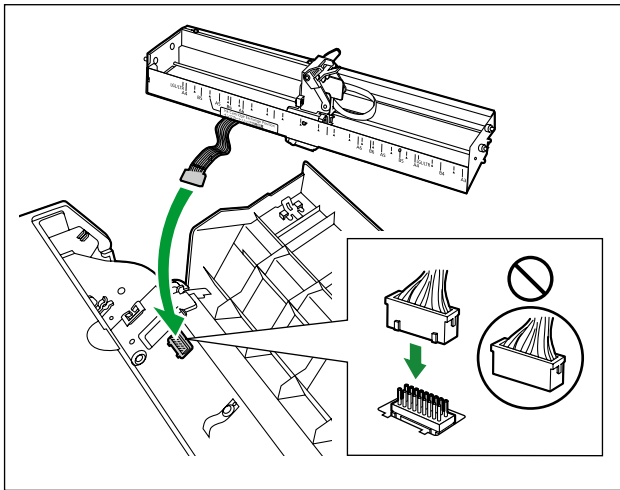

Notice

- Be sure to correctly match the rib with the slot prior to inserting the connector.

4. While keeping the direction of the imprinter as shown in the diagram below, insert the pins (①) on both sides into the guides, and insert the pins (②) on both sides into the guides until they are locked by the springs (③).

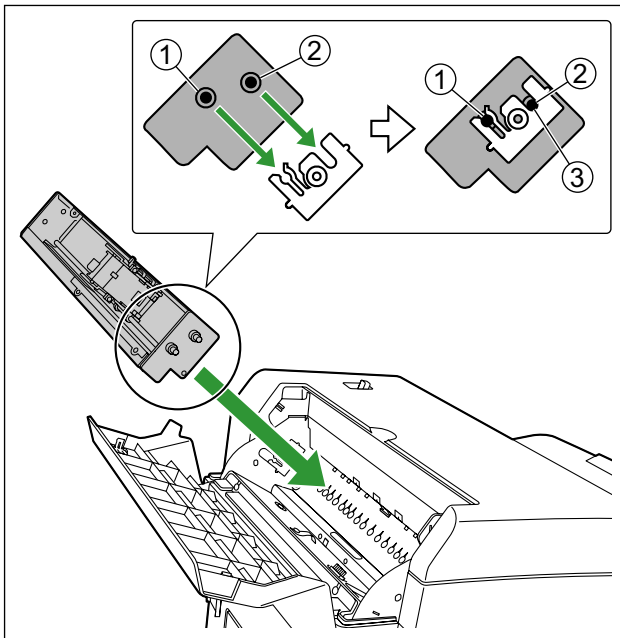

5. Close the imprinter door.

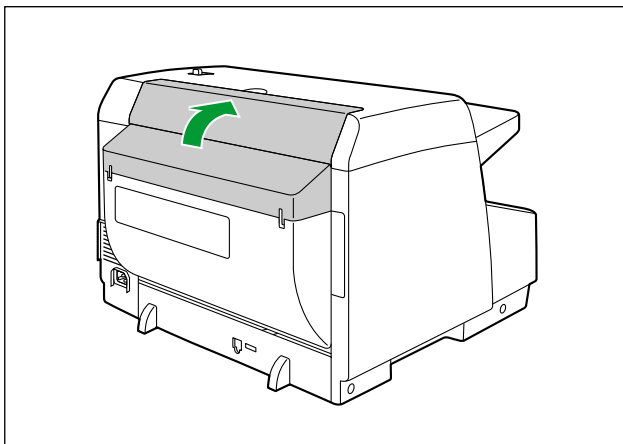

6. Set the power switch of the scanner to "I" (ON).

Note

- For details on installing an ink cartridge, refer to "Installing the Ink Cartridge" (page 77).

Installing the Ink Cartridge

Install the ink cartridge in the imprinter.

1. Set the power switch (①) of the scanner to "○" (OFF).

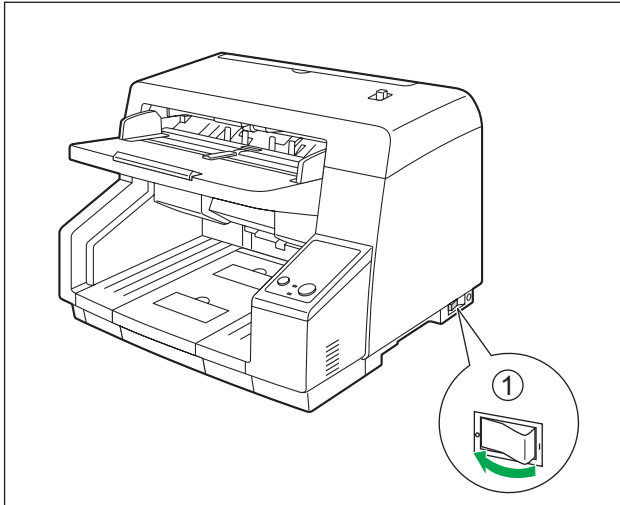

2. Remove the protective tape.

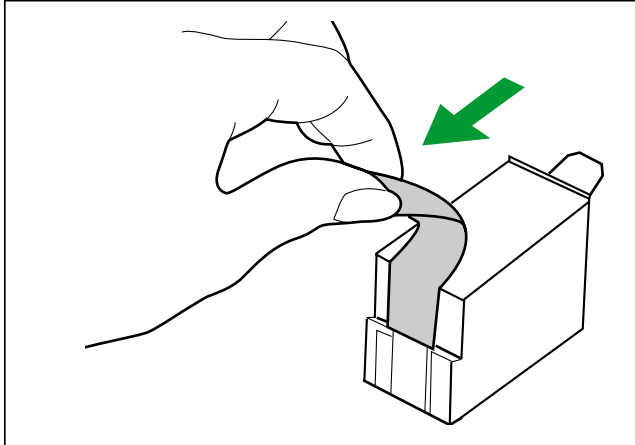

3. Move the carriage to the ink cartridge exchange position.

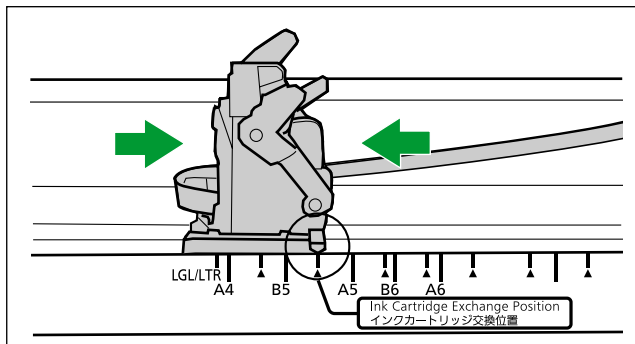

Notice

- Adjust the position following the label on the imprinter.

4. Insert the ink cartridge into the carriage.

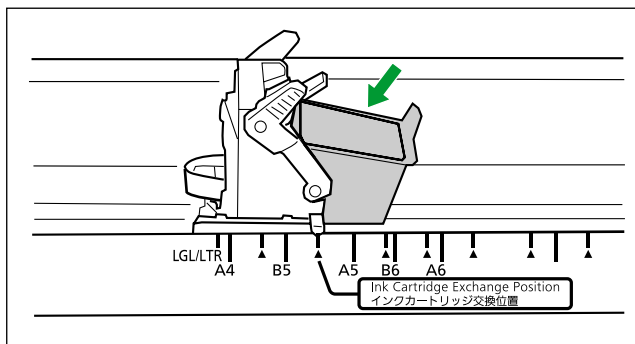

5. Lock the ink cartridge adjustment lever (①).

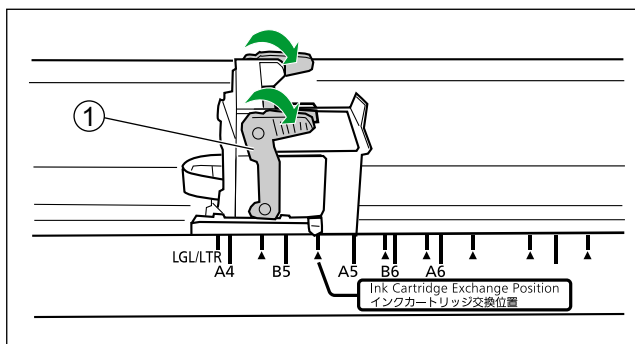

Removing the ink cartridge

1. Set the power switch of the scanner to "○" (OFF).
2. Move the carriage to the ink cartridge exchange position.

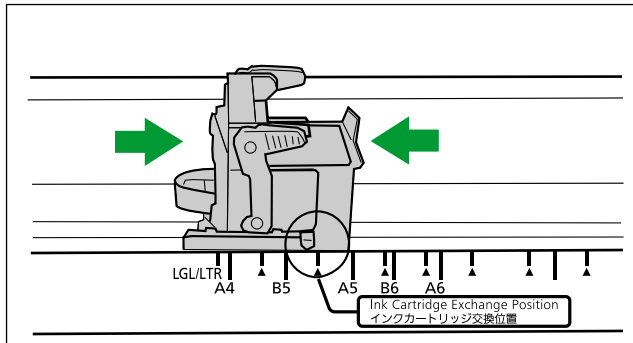

Notice

- Adjust the position following the label on the imprinter.

3. Pinch the ink cartridge adjustment lever (①) and lift it.

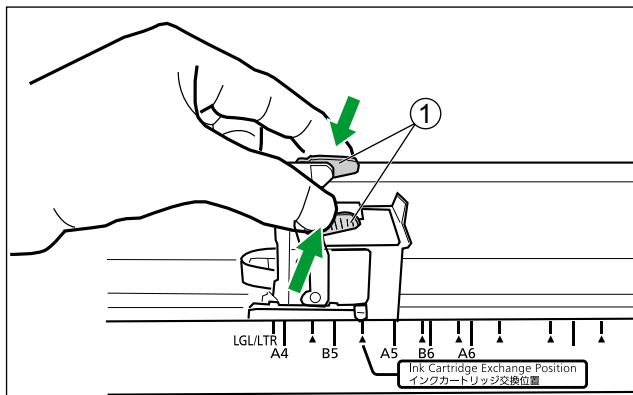

4. Remove the ink cartridge (①).

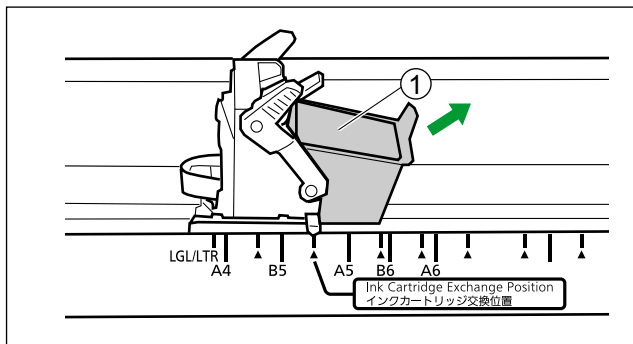

Printing

Adjusting the imprinter printing position

1. Move the carriage to the desired printing position, and align the indicator (①) with the "▲" mark (②).
 - The "▲" mark indicates the printing position. Printing is not available in any other position.

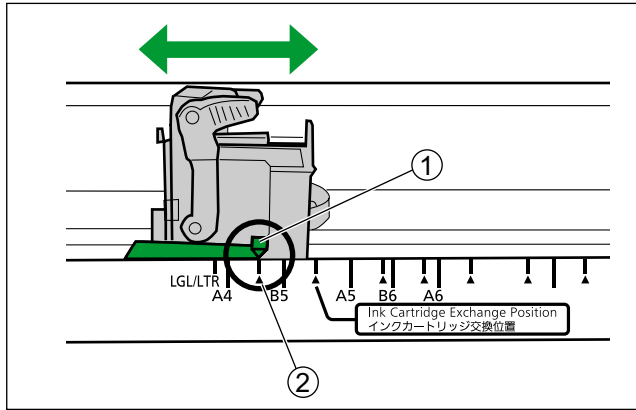

Printing Position

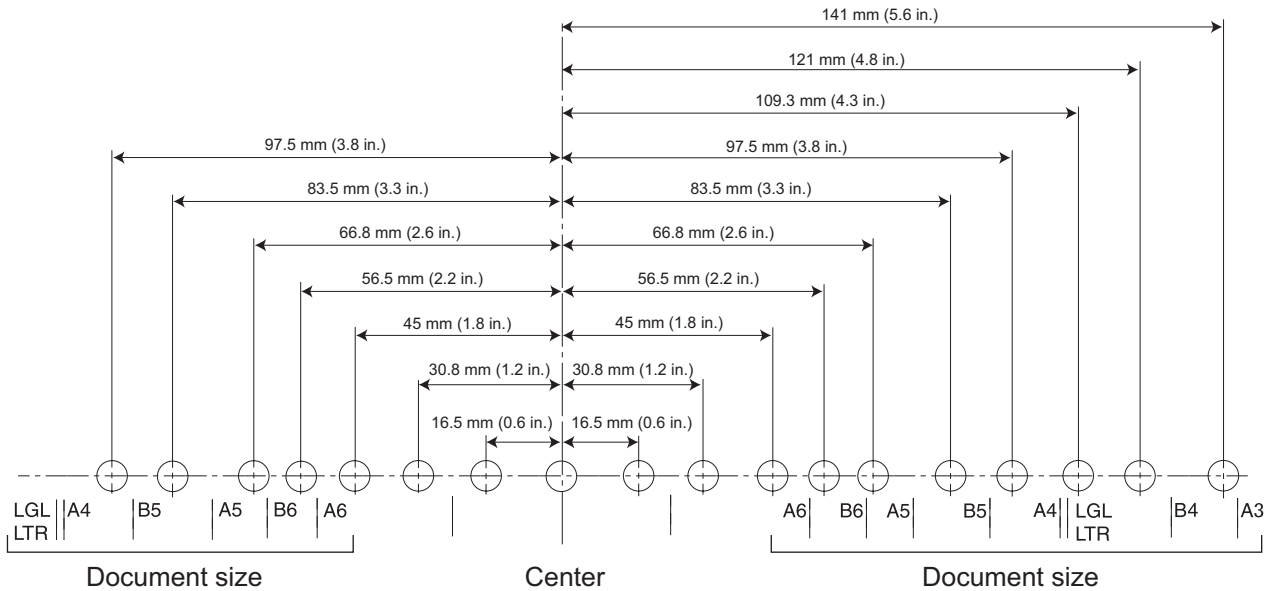

Printing

Printing can be set from the ICP program and the TWAIN and ISIS drivers. For details, refer to the help for ICP or PIE.

Troubleshooting

If a problem occurs while the scanner is being used, check the following items and check the scanner status with the User Utility. If the unit still malfunctions, turn it OFF, unplug the power cord and call for service.

Symptom	Possible Cause	Remedy
The ready indicator does not light when the power switch is turned ON.	The power cord is not plugged in.	Insert the power plug firmly.
	Problem with power supply.	Disconnect the scanner from the electric outlet and call for service.
The computer does not recognize the scanner. The scanner is not functioning correctly.	The scanner is not connected to the computer correctly.	Connect the USB cable correctly.
	The software is not installed correctly.	Uninstall the software from the computer, and then install the software again. (Refer to "Installing the Software" in the Installation Manual.)
	The USB interface of the computer is not installed correctly.	Check the computer whether the USB interface of your computer is installed correctly using the device manager's property.
	The scanner is connected via USB hub.	Do not connect via USB hub.
	There is a problem with the USB cable.	Use the included USB cable or a certified Hi-speed USB 2.0 cable.
Scan speed is slow.	The scanner is connected over a USB 1.1 connection.	Connect over USB 2.0.
The document has been loaded on the hopper, but the scanner does not start scanning.	The document is not loaded properly.	Load the document correctly. (page 22)
	The sensor cannot detect the document as the edge of the document is curled.	Flatten the document (page 19) and load it again (page 22).

Symptom	Possible Cause	Remedy
Double feeding occurs frequently or the scanner stops loading while scanning.	The paper feed roller, separation roller, double feed prevention roller, drive rollers, or free rollers are dirty.	Clean the paper feed roller, separation roller, double feed prevention roller, drive rollers, or free rollers. (page 56)
	The sensors and/or reflector plate are dirty.	Clean all of the sensors and the reflectors. (page 60)
	The paper feed roller, separation roller, or double feed prevention roller have become worn down.	Replace the paper feed roller module (page 65), or double feed prevention roller (page 69).
	Right and left sides of the document to be scanned are not the same in height, because of curling or folding.	Flatten the document (page 19) and load it again after reducing the pages.
	The document is printed on an unsupported type of paper or thick paper.	Make a copy of the document on paper of an acceptable type and thickness (page 19), and scan the copy.
	The length of the paper is too short.	Make a copy of the document on paper of an acceptable size (page 19), and scan the copy.
	The scanning method is set to manual.	Set the scanning method to continuous scanning (Auto) with the manual feed selector. (page 14)
	The document is not aligned correctly.	Realign the document. (page 22)
	The document set on the hopper has too many pages.	Remove pages from the document until it is under the limit mark on the document guides.
Paper jams occur frequently.	The document is wrinkled.	Smooth out the document.
	The rollers are dirty.	Clean the rollers. (page 56)
	The sensors and/or reflector plate are dirty.	Clean all of the sensors and the reflectors. (page 60)
	The document is not aligned correctly.	Realign the document. (page 22)
	The document set on the hopper has too many pages.	Remove pages from the document until it is under the limit mark on the document guides.

Symptom	Possible Cause	Remedy
Scanned image is skewed.	The document guides are not adjusted to the size of the document to be scanned, or the document to be scanned is set slanted on the hopper.	Adjust the document guides properly to the size of the document to be scanned (page 22).
	Right and left sides of the document to be scanned are not the same in height, because of curling or folding.	Flatten the document (page 19) and load it again after reducing the pages.
The scanned document is blank.	The document to be scanned was loaded upside down.	Load the document correctly. (page 22)
Vertical lines appear on the scanned document.	The scanning glass is dirty.	Clean the conveyor, self-cleaning brushes, and the ion outlets (page 53), and then clean the scanning glass (F and B) (page 60).
The scanning density is uneven.	The scanning glass is dirty.	Clean the scanning glass (F and B). (page 60)
	The quantity distribution of light varies.	Adjust shading. (page 84)
The color of the scanned document is extremely different from the original document.	The settings of the computer monitor are wrong.	Adjust the computer monitor settings.
Dark spots or noise appear on the scanned documents.	The scanning glass is dirty.	Clean the conveyor, self-cleaning brushes, and the ion outlets (page 53), and then clean the scanning glass (F and B) (page 60).

If you still experience problems after following these suggestions, please contact our Technical Support Department at 1-800-726-2797 for further assistance. (U.S.A. only)

Shading Adjustment

About shading adjustment

The shading adjustment function corrects variations in the lamp intensity and pixel sensor sensitivity, and reduces unevenness in density in scanned images. It can be carried out by means of the User Utility using the special shading paper, which is provided with this scanner.

When shading adjustment is required

Perform shading adjustment when the density and brightness of sections of scanned images is considerably uneven, or when image quality does not improve after cleaning the inside of the scanner.

Before proceeding with the shading adjustment

Before beginning shading adjustment, thoroughly clean the scanning glass (F), scanning glass (B), conveyors in the scanning area, self-cleaning brushes, ion outlets, and all rollers.

If you perform shading adjustment while these parts are dirty, lines will appear on scanned images.

Shading adjustment procedure

1. Start the User Utility.
2. Click "User Shading" on the main menu, and operate as the image display dictates.

Note

- For further details, refer to section "[User Shading]" in the help for User Utility.

Notice

- If the shading adjustment has not been performed properly, then lines might appear on scanned images even after adjusting the shading or lines might not be eliminated even after cleaning the scanning glass. Clean the parts, and then adjust the shading again.

Repacking Instructions

It is highly recommended that you keep the original carton and *ALL* packing materials. If you need to transport or ship the scanner, please follow these instructions.

Note

- Improper repacking of the scanner may result in a service charge to repair the scanner.
- Please use the original carton and all of the original packing materials.
- The scanner should be handled in the correct (horizontal) position.

Required Materials

- Original scanner carton and packing materials
 - Shipping tape and scissors
1. Unplug the power cord from the outlet, and remove the power cord and USB cable from the scanner.
 2. Return the exit stopper and extension sub tray to their original (non-extended) positions.
 3. Remove the double feed prevention roller (page 70).

4. Pack the scanner.

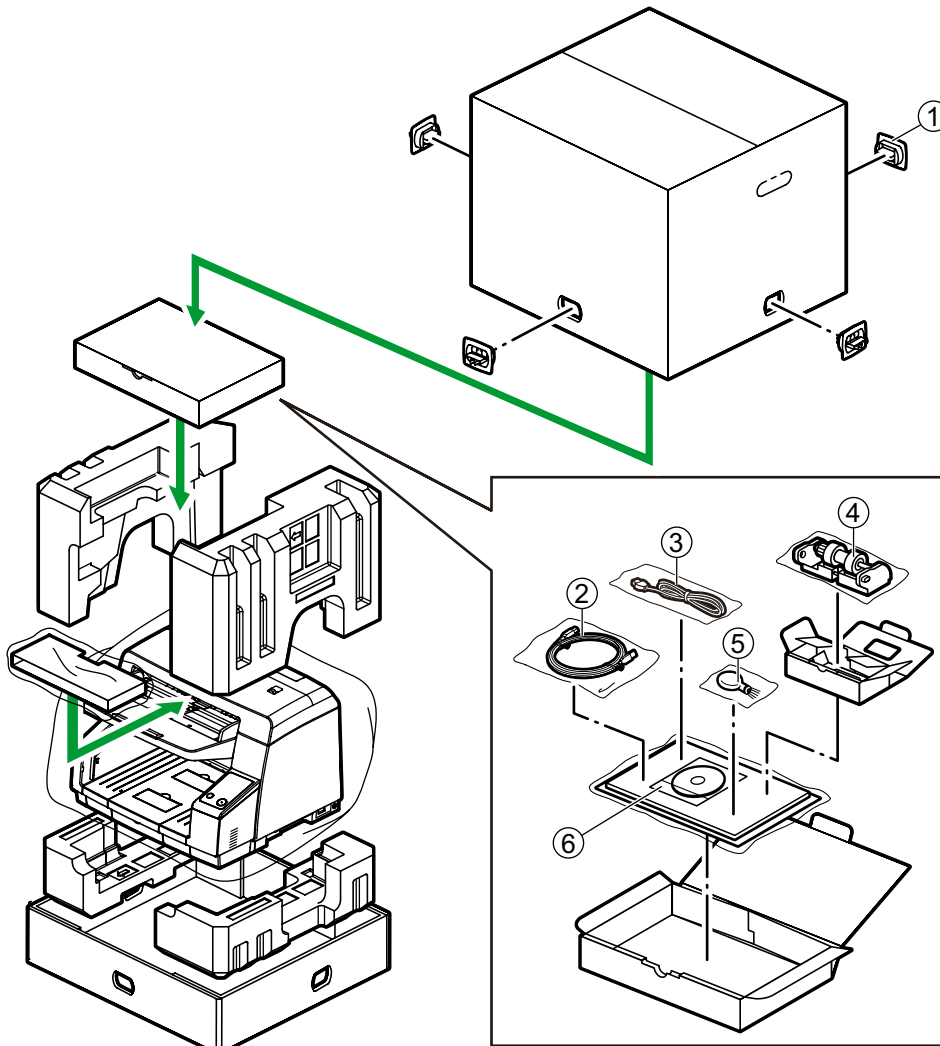

- ① Joint
- ② USB cable
- ③ Power cord
- ④ Double feed prevention roller
- ⑤ Blower
- ⑥
 - Drivers & Utilities / Manuals CD-ROM
 - Installation Manual
 - Shading paper
 - Roller cleaning paper

Specifications

Item		KV-S5055C	
Scanning	Scanning face		Duplex
	Scanning method		Front side: CCD (600 dpi) Back side: CCD (600 dpi)
	Scanning speed ^{*1} (portrait)	Binary / color 300 dpi	Simplex A4: 50 pages/min. Duplex A4: 100 images/min.
	Scanning speed ^{*1} (landscape)	Binary / color 300 dpi	Simplex A4: 60 pages/min. Duplex A4: 120 images/min.
	Resolution		100 – 600 dpi (1 dpi step) Optical: 600 dpi (Main and Sub feeding directions)
	Tonal gradation		Binary, Grayscale (8 bit), Color, MultiStream: Binary & Grayscale, Binary & Color
	Image control		Image emphasis, Dynamic threshold, Automatic separation, Invert, White level from paper
	Compression		JPEG (color, grayscale)
	Maximum image size		305 × 2,540 mm (12.01 × 100 in.)
	Paper ^{*2}	Size	48 × 70 mm (1.9 × 2.75 in.) to 297 × 432 mm (11.7 × 17 in.)
		Thickness	0.04 – 0.2 mm (1.6 – 7.9 mils) Note: 1 mil = 0.001 in.
		Weight	20 – 157 g/m ² (5 – 42 lbs.)
Hopper capacity		200 sheets (75 g/m ² [20 lbs.] fresh paper)	

*1 The scanning speed differs depending on the host computer, the operating system, the application, the measuring method, the quantity of data in the image, and the paper type. The scanning speed depends on a measuring method of Panasonic.

*2 Scan quality cannot be guaranteed for documents with a non-standard size.

"Weight in pounds" of paper represents the weight of 500 [432 × 559 mm (17 × 22 in.)] sheets.

Appendix

Item		KV-S5055C	
Scanner	External dimensions (Width × Depth × Height)		468 × 444 × 339 mm (18.5 × 17.5 × 13.4 in.)
	Weight		18 kg (40 lbs.)
	Power requirement		AC100 – 120 V, 50/60 Hz, 1.0 A AC100 – 240 V, 50/60 Hz, 1.0 – 0.5 A
	Power consumption	Maximum (Scanning)	1.0 A (AC100 – 120 V) 0.5 A (AC220 – 240 V)
		Minimum (Standby)	0.4 A (AC100 – 120 V) 0.2 A (AC220 – 240 V)
Sleep mode		3.5 W or less (AC100 – 120 V) 3.5 W or less (AC220 – 240 V)	
Operating Environment			Temperature: 15 – 30 °C (59 – 86 °F), Humidity: 20 – 80 % RH
Storage Environment			Temperature: 0 – 40 °C (32 – 104 °F), Humidity: 10 – 80 % RH

Index

A

AC inlet 15
 ADF door 14
 ADF door release 14

B

Background color 43
 Blower 52, 86

C

Cleaning the conveyor 53
 Cleaning the rollers 56
 Cleaning the scanner 49
 Cleaning the sensors 60
 Compression 87
 Computer 4
 Control panel 14, 16
 Control sheets 40
 CPU 4

D

Document feeder 49
 Document guides 14
 Document guides selector 14
 Documents
 Acceptable documents 19
 Mixed paper conditions 20
 Scanning documents 22
 Unacceptable documents 21
 Double Feed Skip key 16
 Drivers & Utilities / Manuals CD-ROM 86

E

ENERGY STAR 4
 Error indicator 14, 16, 17
 Exit slot 47, 49
 Exit stopper 14
 Exit sub guide 14
 Exit tray 14
 Extension sub tray 14
 External dimensions 88

F

Fan exhaust vent 15, 50

H

Hard disk 4
 Hopper 14
 Hopper capacity 87

Hopper extension tray 14

I

Image control 87
 Imprinter door 15
 Imprinter unit 64, 74
 Ink cartridge 64, 77
 Interface 4

J

Joint 86

L

Limit mark 25, 33

M

Manual feed selector 14
 Memory 4

O

Operating Environment 88
 Operating system 4
 Optional units 64

P

Paper 87
 Paper feed roller module 65
 Paper jams 46
 Power consumption 88
 Power cord 15, 86
 Power requirements 88
 Power switch 14, 18
 Printing 80

R

Ready indicator 14, 16, 17
 Reference plate 43, 61
 Reflectors 62
 Repacking 85
 Replacement parts 64
 Replacing parts 65
 Resolution 87
 Roller cleaning paper 9, 51, 64, 86
 Roller exchange kit 64
 Rollers
 Double feed prevention roller 58, 69
 Drive rollers 58
 Free rollers 58
 Paper feed roller 58
 Separation roller 58

Index

S

- Safety information 8
- Scanning face 87
- Scanning glass 61
- Scanning method 87
- Scanning speed 87
- Sensors
 - Double feed detector 61
 - Paper sensor 61
 - Slip detect sensor 61
 - Starting sensor 61
 - Waiting sensor 61
- Shading adjustment 84
- Shading paper 86
- Specifications 87
- Start/Stop key 16
- Status indicators 16
- Storage Environment 88
- System Requirements 4

T

- Tonal gradation 87
- Troubleshooting 81

U

- USB cable 86
- USB connector 15
- User Utility 59, 73

W

- Weight 88

Panasonic System Networks Company of America
Unit of Panasonic Corporation of North America
One Panasonic Way, Secaucus, New Jersey 07094

Panasonic Canada Inc.
5770 Ambler Drive, Mississauga, Ontario, L4W 2T3

Panasonic Business Systems U.K.
A Division of Panasonic U.K. Ltd.
Willoughby Road, Bracknell, Berkshire, RG12 8FP

Panasonic Marketing Europe GmbH
Hagenauer Strasse 43, 65203 Wiesbaden, Germany
For information of Compliance with EU relevant Regulatory
Directives, Contact to Authorised Representative:
Panasonic Testing Centre
Panasonic Marketing Europe GmbH
Winsbergring 15, 22525 Hamburg, Germany

Panasonic Corporation
Web Site: <http://www.panasonic.net/>