

*Sunbeam*

# Contact Health Grill

Instruction/Recipe Booklet

GC4610

Please read these instructions carefully  
and retain for future reference.



# Contents

<b>Sunbeam Safety Precautions</b>	<b>1</b>
<b>Features of your Contact Health Grill</b>	<b>2</b>
<b>Using your Contact Health Grill</b>	<b>5</b>
<b>Hints for best results when grilling</b>	<b>6</b>
<b>Care and Cleaning</b>	<b>7</b>
<b>Contact Health Grill Recipes</b>	
<b>Beef</b>	<b>8</b>
<b>Lamb</b>	<b>10</b>
<b>Pork</b>	<b>11</b>
<b>Poultry</b>	<b>12</b>
<b>Seafood</b>	<b>14</b>
<b>Vegetable</b>	<b>17</b>
<b>Marinades</b>	<b>20</b>

تأكد من تفهم احتياطات السلامة المذكورة اعلاه

請務必理解上述的安全預防措施。

Assurez-vous que les précautions ci-dessus relatives à la sécurité sont bien comprises

Versichern Sie sich daß die obenstehenden Sicherheitsmaßnahmen Verstanden werden

Βεβαιώνετε πως οι παραπάνω προφυλάξεις ασφαλείας γίνονται κατανοητές

Pastikan bahwa tindakan-tindakan keselamatan seperti di atas dimengerti anda

Accertatevi che le suddette norme di sicurezza siano comprese a dovere

- 上記の注意事項をよくお読みになり、安全を御確認ください

Уверете се дека погоре споменатите мерки на претпазливост се добро разбрани

Asegúrese de que las precauciones de seguridad precedentes sean bien comprendidas

کاری بکنید کہ احتیاط‌های بالا حتماً درک بشوند

ต้องแน่ใจว่า ข้อควรระวังเรื่องความปลอดภัยข้างต้น เป็นที่เข้าใจกันดี

Yukarda belirtilen güvenlik önlemlerinin anlaşılığınızda emin olunuz

Xin kiểm chắc rằng những biện pháp làm an toàn kể trên được hiểu rõ

# Sunbeam's Safety Precautions

## SAFETY PRECAUTIONS FOR YOUR SUNBEAM CONTACT HEALTH GRILL.

- Use well away from walls and curtains.
- Avoid using on metal surfaces e.g. sink.
- Do not use in confined spaces.
- Do not immerse the unit in water.
- Ensure that the cord is kept well away from the cooking plates during use.
- Ensure the drip tray is in position before grilling.
- Do not touch the outside or the top of the grill when in use.
- Ensure you use the handle to open the grill plate. Avoid touching hot surfaces.
- This grill may generate steam from between the grill plates while cooking and when the top plate is opened.
- Take care when removing food from the grill.

---

**Sunbeam are very safety conscious when designing and manufacturing consumer products, but it is essential that the product user also exercise care when using an electrical appliance. Listed below are precautions which are essential for the safe use of an electrical appliance:**

- Read carefully and save all the instructions provided with an appliance.
- Always turn the power off at the power outlet before you insert or remove a plug. Remove by grasping the plug - do not pull on the cord.
- Turn the power off and remove the plug when the appliance is not in use and before cleaning.
- Do not use your appliance with an extension cord unless this cord has been checked and tested by a qualified technician or service person.
- Always use your appliance from a power outlet of the voltage (A.C. only) marked on the appliance.
- Close supervision is necessary when your appliance is being used near children or infirm persons.
- Never leave an appliance unattended while in use.
- Young children should be supervised to ensure that they do not play with the appliance.
- Do not use an appliance for any purpose other than its intended use.
- Do not place an appliance on or near a hot gas flame, electric element or on a heated oven. Do not place on top of any other appliance.
- Do not let the power cord of an appliance hang over the edge of a table or bench top or touch any hot surface.
- For safety reasons and to avoid maintenance by unskilled persons, some appliances are 'sealed' using tamperproof screws. Such appliances should always be returned to the nearest Sunbeam Appointed Service Centre for adjustment or repair if required.
- Do not operate any electrical appliance with a damaged cord or after the appliance has been dropped or damaged in any manner. If damage is suspected, return the appliance to the nearest Sunbeam Appointed Service Centre for examination, repair or adjustment.
- For additional protection, Sunbeam recommend the use of a residual current device (RCD) with a tripping current not exceeding 30mA in the electrical circuit supplying power to your appliances.
- Do not immerse the appliance in water or any other liquid unless recommended.

If you have any concerns regarding the performance and use of your appliance, please visit [www.sunbeam.com.au](http://www.sunbeam.com.au) or contact the Sunbeam Consumer Service Line.

Ensure the above safety precautions are understood.

# Features of your Contact Health Grill

## Warm up and Ready lights

'Warm up' light indicates when the Contact Health Grill is switched on and heating. The 'Ready' light indicates that it is ready to use.

## Thermostat Heat Settings

Thermostatically controlled temperature settings. 2 variable settings; Medium for vegetables and Grill for meats.

## Cool Touch Handle

Remains cool to touch preventing burns.

## Dupont Teflon® Platinum Pro with ScratchGuard™ Non-Stick Coating

Safe to use with metal utensils. Up to 10 times more scratch-resistant than other non-stick coatings.

## Sloping Grill Plate

The sloping grill plate drains fat away from the food whilst cooking for a healthier meal.

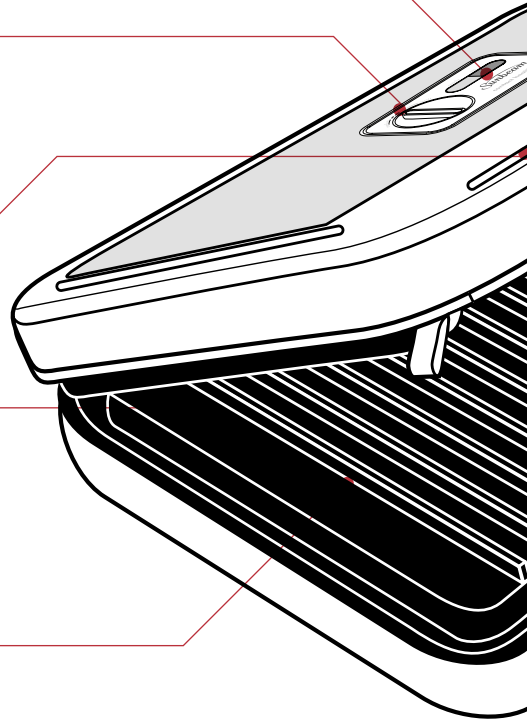

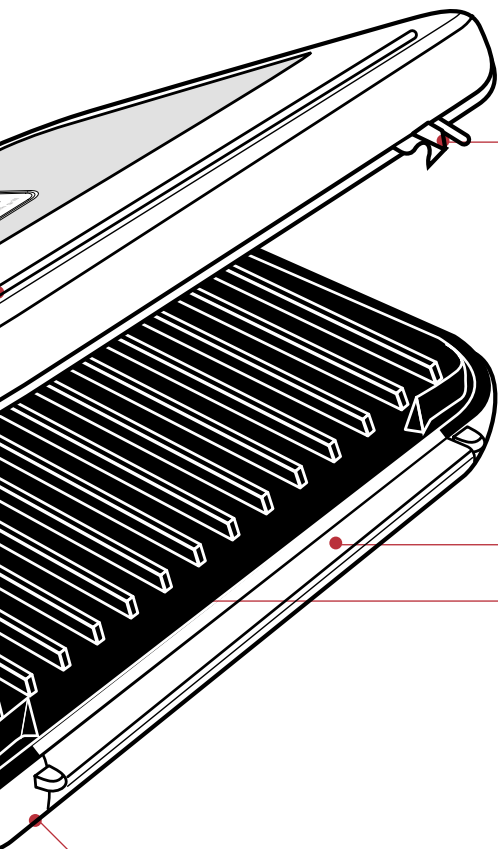

**Self Lock Clips**

Self locking clips for easy handling and vertical storage.

**2400 watts**

The Contact Health Grill is high powered with 2400 watts of commercial power for super fast heating and more superior consistent grilling.

**Detachable Drip Tray**

Detachable drip tray catches fats and juices preventing overflow onto bench tops. Ensure this tray is in position before grilling.

**Non-stick Grill Plates**

The high grade non-stick cooking plates sear meat on both sides at the same time for fast healthy cooking. The non-stick plates make for easy wipe down cleaning; ingredients do not stick and can be easily wiped down after use.

**Vertical Storage with Cord Wrap**

The cord simply wraps around the base of the unit enabling the product to be stored conveniently in the upright position.

# Features of your Contact Health Grill

## DuPont Teflon® - Platinum Pro with ScratchGuard™ Non-Stick Coating

Your Sunbeam Contact Health Grill features DuPont's® toughest non-stick coating produced to date - Platinum Pro with ScratchGuard.

DuPont is the world leader in non-stick coatings with the introduction of Teflon dating back to 1938. Today more than 2 billion households have Teflon non-stick coated cookware.

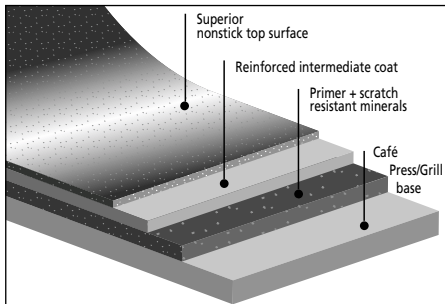

Teflon Platinum Pro is a premium 3 layer non-stick coating. It features special scratch resistant minerals causing metal utensils to slide over these particles without damaging the Teflon matrix.

This preserves the release properties of the non-stick coating during the life of the Contact Health Grill.

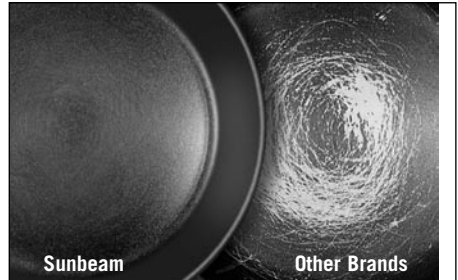

Results from DuPont's 'In-house Cooking Abuse Test'

The end result is a non-stick coating that can be treated like ordinary cookware, enabling the use of metal utensils such as spatulas and spoons, but not sharp utensils. So tough is the new Teflon Platinum Pro coating that it is up to 10 times more scratch resistant than other non-stick coatings\*.

The image shown here is an example of the performance of Teflon Platinum Pro against an 'other' non-stick coating. Each surface has undergone 5 cycles of the DuPont In-House Abuse Test.

The Teflon Platinum Pro only has some surface scuffing, whereas the 'other' non-stick coating has deteriorated badly.

*\* The images shown here and performance claims are based upon the DuPont In-House Cooking Abuse Test used to evaluate scratch resistance and release properties of non-stick coatings.*

**\*\*NOTE: The DuPont Teflon® Platinum Pro with ScratchGuard™ is only available on certain models.**



# Using your Contact Health Grill

## **Before using your Contact Health Grill**

Before using your Contact Health Grill for the first time, the non-stick cooking plates must be seasoned. Turn the power ON and pre-heat until the Ready Light illuminates.

Wipe a small amount of butter, margarine or oil onto the plates, rub lightly and wipe away any excess.

**Note:** When using your Contact Health Grill for the first time you may notice a fine smoke haze being emitted from the unit. This is normal. It is due to the initial heating of internal components.

## **Using your Contact Health Grill**

1. Plug the power cord into a 230-240 volt AC power outlet.
2. Turn the power ON.
3. Select your desired temperature setting to suit the type of food you wish to cook. Turn the temperature dial to Medium or Grill.
4. Preheat until the Ready Light (green) illuminates.
5. After you have completed grilling or toasting, turn the power OFF.

**Note:** Ensure that the cord is kept well away from the cooking plates when in use.

## **Grilling Meats and Vegetables**

**Note:** Always turn your temperature dial to Grill and pre-heat for 3-5 minutes. The Ready Light will illuminate.

1. Always spray the grill plates with cooking spray before placing meat, seafood or vegetables onto the grill plate.
2. Gently lower the lid (if desired) to ensure even cooking of your food everytime.
3. When cooking some foods you may want to re-spray the grill plates to prevent food from sticking.
4. The cooking plates are coated in a durable high grade non-stick coating. Some foods that are marinated or coated may cause the food to stick to the grill plates.

To free the food use a plastic spatula or wooden spoon. Never use a sharp metal object as this will damage the non-stick surface.

**Note:** The Warm Up and Ready Lights are thermostatically controlled and will cycle on and off during the cooking cycle to ensure that the correct temperature is maintained.

**Caution:** Do not touch the outside or the top of the unit, when in use. Ensure you use the handle to open the top grill plate. Avoid touching hot surfaces. This Contact Health Grill may generate steam from between the grill plates while food is cooking and when the top plate is opened. Take care when removing food from the grill.

# Hints for best results when grilling

1. Tender cuts of meat such as scotch fillet and sirloin are ideal for grilling. Tougher cuts of meat such as topside or blade steak will tenderise if marinated for a few hours or overnight.
2. Avoid overcooking meat as the texture will toughen.
3. Recommended cuts;  
Beef = Sirloin, Rump, Rib Eye  
          Fillet or T-Bone  
Lamb = Leg Steak, Fillet, Loin or Cutlets  
Pork = Butterfly Steaks, Spare Ribs,  
          Leg Steaks or Fillets
4. You can also grill diced meat on skewers for kebabs.
5. The Contact Health Grill can grill meats over 1 inch (2.5cm) thick with ease. If cooking meats with a bone it is recommended that it is no larger than (1.5cm) thick to ensure even cooking.
6. Ideal for cooking a variety of meats, including beef, fish and poultry. Take care when grilling fish, use a plastic spatula.
7. The sloped grilling surface allows the fats and juices to drain into the drip tray for healthy, fat free cooking.
8. When cutting meats, chicken, vegetables and or seafood for kebabs, cut evenly and uniform in size to ensure even cooking. Never cross - contaminate foods. Do not cut raw vegetables and raw meats with the same knife or on the same chopping board. Try to use separate chopping boards for meats, vegetables and seafood. Do not cut cooked meats on the same chopping board as you prepared the raw meat unless the board and knife have been thoroughly sanitised and cleaned in hot soapy water.



# Care and Cleaning

## **DuPont Teflon® Platinum Pro Non-stick Coating**

Your Contact Health Grill features a special scratch and abrasive-resistant non-stick coating that makes it safe to use metal utensils when cooking.

Sunbeam recommends that care is taken with the non-stick coating particularly when using metal utensils.

Always turn the power **OFF** and **REMOVE** the plug from the power point before cleaning.

**Do not use sharp objects or cut food on top of the Contact Health Grill.** Sunbeam will not be liable for damage to the non-stick coating where metal utensils have been misused.

When cleaning the non-stick coating do not use metal (or other abrasive) scourers. After cleaning, dry the Contact Health Grill and lid thoroughly with a soft cloth before storing.

## **Quick cleaning method**

Always turn the power OFF and remove plug after use and before cleaning. The cooking plates are coated with a non-stick surface, and there are no dirt traps, therefore little cleaning is required. Once cooled, simply wipe the cooking plates with a dampened cloth.

**Do not immerse your Contact Health Grill in water or any other liquid. Do not use abrasive scouring pads or powders.**

**Do not place your Contact Health Grill in a dishwasher.**

## **To clean the exterior**

Simply wipe over with a dampened cloth. Do not use steel wool, scouring pads or abrasive cleaners as these will scratch the surface.

## **Storage**

Your Contact Health Grill will store in an upright position in cupboards, shelves or on the bench top. Simply bring the plates together and use the self locking clips to lock the unit.

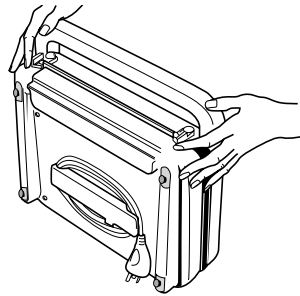

Always allow the grill to cool after use. Once cooled, you can clean the cooking plates.

Always allow the contents of the drip tray to cool before removing the tray from its position and discarding the contents.

Wash the drip tray in warm soapy water.

**Always clean after each use to prevent a build up of cooking residue on the grill.**

**Do not immerse your Contact Health Grill in water or any other liquid.**

## **To clean the exterior**

Simply wipe over with a dampened cloth.

# Contact Health Grill Recipes

Turn temperature control to 'Grill' Setting

## BEEF

### Tasty Burgers

Serves 4

500g lean beef mince  
2 small onions, finely chopped  
¾ cup dry breadcrumbs  
1 egg, lightly beaten  
2 tablespoons tomato paste  
2 tablespoons parsley, finely chopped (optional)

1. Mix all ingredients together in a bowl. Divide mixture into 8 equal portions and shape into patties. Flatten slightly. Place onto a plate or tray, cover and refrigerate for 30 minutes or until required.
2. Pre-heat grill for 3-5 minutes. Spray grill plates with cooking spray. Grill burgers 6-8 minutes or until tender.
3. Serve on a toasted burger bun with salad, cheese and your choice of sauce.

### Recipe suggestion:

- Substitute the lean beef mince for lean chicken, veal, lamb or pork mince.
- Add freshly chopped chilli or dried chilli flakes to mince mixture before cooking to add a spicy flavour.
- Freshly chopped garlic can also be added.

### Beef Fajitas

600g skirt steak  
½ cup orange juice  
½ cup pineapple juice  
½ cup soy sauce  
1 red capsicum, sliced  
1 yellow capsicum, sliced  
1 red onion, sliced  
½ iceberg lettuce, shredded  
1 cup grated cheese  
½ cup sour cream  
½ cup salsa  
8 flour tortillas, warmed

1. Trim any fat from beef. Place beef in a deep dish and pour over the combined juices and soy sauce. Marinate in refrigerator for at least 2 hours.
2. Preheat grill for 3-5 minutes. Remove beef from marinade; reserve liquid. Cook beef in grill for about 5-8 minutes or until cooked as desired. Remove from grill and cover with foil while the vegetables cook.
3. Place vegetables in grill and cook for 2 minutes. Pour over a little of the reserved liquid over the vegetables and cook for a further 1 minute.
4. Slice beef across the grain into thick slices.
5. To serve fajitas, place a little of each of the beef, vegetables and remaining ingredients in the flour tortilla and roll up.

# Contact Health Grill Recipes continued

## Pepper Steak

**Serves 4**

4 pieces thin fillet steak  
2 tablespoons crushed black peppercorns

### Sauce

30g butter  
¾ cup dry white wine  
1 tablespoon brandy

1. Press the crushed pepper into the steak on both sides. Refrigerate steaks for 1 hour.
2. Pre-heat Contact Health Grill for 3-5 minutes.
3. Spray grill plates with cooking spray. Cook steaks for 10-12 minutes or as desired.
4. Combine butter, wine and brandy in a saucepan over low heat. Bring to the boil. Strain through a fine sieve.
5. Serve sauce over steak.

## Thai Style Beef Salad

**Serves 4**

500g beef sirloin or backstrap, trimmed of fat and sinew

### Salad

3 cups mesclun lettuce leaves  
12 mixed cherry tomatoes (red, yellow green), quartered  
1 Lebanese cucumber, thinly sliced on the diagonal  
1 small Spanish onion, thinly sliced  
½ cup fresh mint leaves, roughly chopped  
½ cup fresh coriander leaves, roughly chopped  
½ cup dry roasted cashew nuts

### Salad dressing

¼ cup caster sugar  
½ cup water  
Juice & zest 2 limes  
1 fresh red chilli chopped or 1 teaspoon dried chilli flakes  
1 teaspoon fish sauce

1. Pre-heat the grill for 3-5 minutes. Spray grill plates with cooking spray.
2. Cook the sirloin for 4-6 minutes. Meat should be brown on the outside but rare in the middle.
3. Remove and wrap in foil. Wait 10-15 minutes before thinly slicing the beef.
4. Combine all of the ingredients together for the salad onto individual plates or in one big serving bowl.

**Dressing:** in a small saucepan combine all the ingredients, bring to the boil, simmer 1-2 minutes, remove and allow to cool.

Top the salad with beef slices and toss in cooled dressing. Serve immediately.

## Contact Health Grill Recipes continued

### LAMB

#### Mediterranean Kebabs-&-Tahini Yogurt Serves-4

##### Kebabs

1kg lamb leg steaks, trimmed, cut into 2cm cubes

1/3 cup olive oil

1 lemon, washed

1/2 cup white wine

2 large cloves garlic, sliced

##### Topping

1 small Spanish onion, finely chopped

3 fresh tomatoes, seeded and chopped

1/4 bunch fresh basil leaves, finely shredded

##### Tahini yogurt

125ml low fat plain yogurt

1/4 cup tahini

Freshly ground black pepper

Soak 12 bamboo skewers in water (for 1 hour)

1. In a large bowl combine the lamb cubes and olive oil.
2. Cut the lemon in half, squeeze juice over lamb and leave the skin halves in the marinade. Add in wine and garlic.
3. Marinate meat for 2 hours or overnight. Thread meat onto skewers.
4. Mix together the onion, tomatoes and basil in a bowl, set aside.

5. Mix together the yogurt, tahini, pepper; set aside.

6. Preheat grill for 3-5 minutes. Spray grill plates with cooking spray. Cook kebabs (6) at a time in two batches for 8-10 minutes each batch. Wrap kebabs in foil after cooking.

7. Serve kebabs sprinkled with combined onion, tomatoes and parsley, top with a generous dollop of tahini yogurt dressing.

##### Note:

- Tahini is a ground sesame seed paste and can be found in supermarkets or health food stores.

#### Satay Lamb Cutlets

Serves 5

10 Lamb cutlets

3/4 cup satay sauce

1 teaspoon ginger

1 clove garlic, crushed

1. Combine satay sauce, ginger and garlic together. Best to marinate in sauce overnight.
2. Pre-heat Contact Health Grill for 3-5 minutes.
3. Spray grill plates with cooking spray. Cook for about 10 minutes or until cooked as desired, brushing with satay sauce.
4. Serve with boiled fragrant rice or mixed salad leaves.

## Contact Health Grill Recipes continued

### **Greek Lamb Souvlaki**

**Serves 6**

700g trim lamb, diced

10 kebab skewers, soaked in water for 1hr

#### **Marinade**

¼ cup lemon juice

1 teaspoon olive oil

1 tablespoon fresh oregano, chopped

1 teaspoon fresh rosemary, chopped

2 cloves garlic, crushed

1. Pre-heat contact grill for 3-5 minutes.
2. Combine all ingredients of marinade together.
3. Spray grill plates with cooking spray. Thread diced lamb onto 10 kebab skewers. Place skewers in a deep dish and pour marinade over skewers.
4. Cook skewers for 10 minutes or until cooked as desired.
5. Serve with Greek salad and hot crusty bread.

### **PORK**

#### **Thyme & Rosemary Pork Medallions** **Serves 5**

4 x 150-200g pork butterfly medallions

2 tablespoons olive oil

seasoned cracked black pepper

1 teaspoon dry thyme leaves

1 teaspoon dry rosemary leaves

1. Place pork medallions into a bowl, pour over olive oil, sprinkle over black pepper, thyme and rosemary. Coat the pork well. Allow pork to marinade for 1 hour or overnight.
2. Pre-heat grill for 3-5 minutes. Spray grill plates with cooking spray. Cook medallions for 6 minutes or until cooked as desired.

3. Serve medallions with creamy mashed potato and a tossed green salad.

#### **Satay Skewers**

**Serves 4**

500g pork meat, trimmed of fat and cut into

2cm strips

½ cup thick ready made satay sauce

¼ cup lemon juice

1 tablespoon olive oil

¼ teaspoon chopped chilli

2 tablespoons freshly chopped coriander or parsley

2 tablespoons finely chopped peanuts

1. Soak 12 bamboo skewers in water for 1 hour.
2. Combine pork meat with satay sauce, lemon juice, olive oil, chilli, coriander and peanuts in a bowl.
3. Marinate 30 minutes or overnight. Thread meat onto skewers.
4. Pre-heat grill for 3-5 minutes. Spray grill plates with cooking spray. Cook (6) skewers in two batches for 5 minutes each batch or until tender.
5. Heat any remaining marinade over a low heat in a frypan until fragrant. Serve over skewers.
6. Serve with steamed jasmine rice topped with chopped coriander and finely chopped peanuts in olive oil.

#### **Note:**

- If you can't get a ready made satay mix, combined together ¼ cup peanut butter with 1 freshly chopped chilli or ¼ teaspoon chilli paste or 1 tablespoon sweet chilli sauce.

## Contact Health Grill Recipes continued

### **Sweet Pork Medallions**

**Serves 4**

4 Pork Loin Medallion Steaks

#### **Marinade**

- 1 tablespoon honey
- 2 tablespoons soy sauce
- 1 teaspoon chilli sauce
- 1 teaspoon oil

1. Combine all ingredients for marinade in a saucepan and stir over low heat until honey has dissolved.
2. Place pork in a flat dish and pour marinade over steaks. Refrigerate for 2 hours.
3. Pre-heat grill for 3-5 minutes.
4. Cook for 10-12 minutes or until cooked as desired.
5. Serve on a bed of pasta or rice.

### **POULTRY**

#### **Thai Style Chicken**

**Serves 4**

- 4 large cloves garlic, peeled
- 3 cm piece ginger, peeled
- 2 large fresh green chilli
- ¼ cup honey
- Juice of 1 lemon

1. 4 x 150-200g meaty chicken thigh fillets, fat and sinue removed, flatten to one thickness and score.

2. Combine garlic, ginger, chilli, honey and lemon juice in a food processor until processed.
3. Spread this over the chicken. Marinate for 30 minutes or overnight.
4. Pre-heat grill for 3-5 minutes. Spray with cooking spray. Cook fillets for 6-10 minutes or until cooked. Check if fillets are cooked by inserting a knife into flesh.
5. Serve with steamed rice noodles topped with fresh herbs.

#### **Mustard Seed & Tarragon Chicken Breasts**

**Serves 4**

- 4 large chicken breasts, fat and sinue removed, cut into 8 flat slices
- 2 tablespoons wholegrain mustard
- 2 tablespoons dijon mustard
- 1 tablespoon dry tarragon leaves

1. Combine chicken with mustards and tarragon leaves. Marinate for 30 minutes or overnight.
2. Pre-heat grill for 3-5 minutes. Spray with cooking spray. Cook chicken for 3-4 minutes or until tender.
3. Serve chicken with a hot potato bake and steamed vegetables.

## Contact Health Grill Recipes continued

### **Honey and Soy Chicken Nibbles**

**Makes 20**

- 10 chicken wings
- 2 tablespoons vegetable oil
- 2 cloves garlic, finely chopped
- 1 teaspoon finely grated ginger
- ½ cup soy sauce
- ¼ cup honey
- ¼ cup dry sherry
- ½ teaspoon five spice powder

Fresh ground pepper to taste

1. Pre-heat grill for 3-5 minutes.
2. Remove and discard wing tips. Cut wings in half at the joint.
3. Combine all other ingredients in a small deep bowl.
4. Dip each wing into the marinade. Spray grill plates with cooking spray.
5. Cook for 15-20 minutes or until cooked throughout.

### **Chicken Vegetable Kebabs**

**Serves 4**

- 8 kebab skewers, soaked in water for 1 hour
- 2 large chicken breasts, cubed
- 2 baby squash, quartered
- 4 cherry tomatoes, halved
- 4 mushrooms halved
- ½ yellow capsicum, chopped in 2 x 2cm pieces

#### **Marinade**

- ¼ cup lemon juice
- 2 tablespoons soy sauce
- 1 clove garlic, crushed

1. Pre-heat grill for 3-5 minutes. Spray grill plates with cooking spray.
2. Thread chicken cubes onto skewers alternatively with squash, tomatoes, mushrooms and capsicum.
3. Combine marinade ingredients and brush over kebabs.
4. Cook kebabs for 8-10 minutes or until desired. Continually brush kebabs with marinade.

# Contact Health Grill Recipes

Turn temperature control to 'Medium' setting

## SEAFOOD

### Oriental Snapper Fillets

Serves 4

4 large snapper fillets

2 tablespoons honey

Juice and zest of orange

3cm piece fresh ginger, grated

1. Place fillets onto a plate. In a small jug combine honey, orange zest and juice, add the grated ginger. Pour this over the fillets and marinate in the fridge for 30 minutes.
2. Pre-heat grill for 3-5 minutes. Spray grill plates with cooking spray. Cook fish fillets for 6-8 minutes until fish is flaky.
3. Serve fish with cooked noodles, steamed green vegetables and soy sauce.

#### Note:

- Fish suggestions: use any low-fat rock fish such as yellowtail, golden eye, striped bass. Boneless white fish fillets such as ling or flake can be used.

### Salmon and Potato Cakes

Serves 4

1 x 210g can pink or red salmon, drained and flaked

2 cups mashed potato, (not too wet)

1 green onion, finely chopped

2 tablespoons parsley (optional)

1 egg, lightly beaten

Sea salt and black pepper

½ cup breadcrumbs for coating

1. In a large bowl combine the salmon, potato, onion, parsley, egg, salt and pepper.
2. Scoop out (8) equal portions of mixture and form 8 balls. Roll in breadcrumbs. Place patties on a plate cover in plastic wrap, refrigerate for 1-2 hours.

3. Pre-heat grill for 3-5 minutes. Spray grill plates with cooking spray. Cook patties (4) at a time 5-7 minutes or until crispy and golden and hot in centre. Using a heat-proof spatula to remove the patties. Half way through cooking you may want to respray the grill plates to prevent patties from sticking.
4. Serve salmon and potato patties with a green salad, lemon and mayonnaise.

### Tandoori Prawn Skewers

Serves 4

24 raw king green prawns, shelled and deveined (leaving head and tails attached)

½ cup low fat yogurt

½ cup tandoori paste

2 tablespoons freshly chopped

coriander or parsley

Lemon wedges and a tzatziki dip for serving

1. Soak (8) bamboo skewers in water for 1 hour. Thread 3 prawns per skewer. Place onto a plate.
2. In a small bowl combine the yogurt, tandoori paste and coriander. Spoon this over prepared prawns. Cover and refrigerate until required.
3. Pre-heat grill for 3-5 minutes. Spray grill plates with cooking spray. Cook (4) skewers at a time. Cooking 3-5 minutes.
4. Serve prawn skewers on a bed of lettuce leaves with lemon wedges and tzatziki dip.

#### Note:

- Prawns can also be cooked in the grill not skewered.



## Contact Grill Recipes continued

### **Garlic Prawns**

**Serves 4**

1kg green prawns, shelled and deveined  
½ cup olive oil  
2 cloves garlic, crushed  
1 tablespoon chopped parsley  
Fresh ground pepper to taste

1. Place all ingredients into a bowl and marinate for 2 hours.
2. Pre-heat grill for 3-5 minutes. Spray grill plates with cooking spray. Cook prawns for 3-5 minutes or until cooked, occasionally brushing with marinade.

### **Mediterranean Octopus**

**Serves 4**

1kg baby Octopus

#### **Marinade**

¼ cup each of green, yellow and red capsicum, finely chopped  
⅓ cup soy sauce  
1 tablespoon oil  
2 tablespoons chopped fresh oregano  
¼ cup lemon juice  
1 clove garlic, crushed  
3 tablespoons dry red wine

1. Clean insides of heads of octopus and remove beaks from legs and place in a bowl.
2. Combine all marinade ingredients and pour over octopus. Refrigerate for 1-2 hours.
3. Pre-heat grill for 3-5 minutes. Spray grill plates with cooking spray. Cook octopus for 15-20 minutes or until tender.

### **Stuffed Calamari**

**Serves 4**

8 small squid/calamari tubes, cleaned

#### **Stuffing**

1 cup breadcrumbs  
⅓ cup parmesan cheese, grated  
1 clove garlic, crushed  
1 egg  
Salt and pepper to taste

1. Combine all stuffing ingredients in a small bowl. Using your hand, mix ingredients together until well combined. If mixture appears too dry, add a few drops of water.
2. Pre-heat grill for 3-5 minutes. Spray grill plates with cooking spray.
3. Place spoonfuls of stuffing into each tube. Secure end with a toothpick.
4. Place calamari onto the Contact Health Grill and cook for 10-15 minutes or until cooked throughout.
5. Remove toothpicks before serving.

## Contact Grill Recipes continued

### **Barbecued Snapper**

- 1 medium sized snapper, cleaned
- 3 tablespoons oil
- 2 tablespoons vinegar
- 1 tablespoon soy sauce

#### **Pine Nut Filling**

- 3 bacon rashers, chopped
- 1/3 cup pine nuts
- 2 green onions
- 2 cups stale breadcrumbs
- 1/4 cup sour cream
- 1 tablespoon chopped fresh chives

#### **Pine Nut Filling**

1. Fry bacon until crisp.
2. Combine remaining ingredients in a small bowl and add bacon. Mix until well combined.

#### **Snapper**

1. Trim fins from the gutted fish. Snip the backbone, tail and head with scissors. Run fingers under the rib bones and pull backbone gently with your fingers. Remove backbone from fish.
2. Stuff fish with pine nut filling and brush with combined oil, vinegar and soy sauce.
3. Pre-heat grill for 3-5 minutes. Spray grill plates with cooking spray.
4. Cook fish for 20-25 minutes or until cooked throughout.

**Serves 4**

### **Citrus Salmon**

- 4 pink salmon cutlets
- Salt and pepper to taste

#### **Marinade**

- Juice of 1 lime
- Juice of 1 lemon
- 1 tablespoon chopped chives
- 2 cloves garlic, crushed
- 1 tablespoon olive oil

1. Place cutlets in a shallow dish.
2. Combine marinade ingredients together and pour over cutlets. Refrigerate for 1 hour.
3. Pre-heat grill for 3-5 minutes. Spray grill plates with cooking spray.
4. Cook salmon for 8-10 minutes continuously brushing with marinade.
5. Season with salt and pepper to taste.

**Serves 4**

# Contact Grill Recipes continued

## VEGETABLE

### Healthy Bean Burgers

**Serves 4**

- 1 x 300g can 4 bean mix, rinsed & drained
- 2 cups cooked rice
- 1 red onion, finely chopped
- 2 tablespoons finely chopped mixed herbs
- Salt and pepper
- 1 tablespoon ground tumeric
- 1 teaspoon saffron threads
- 2 eggs, lightly beaten
- 2 tablespoons wholemeal plain flour
- ¼ cup rice flour
- 2 tablespoons sesame seeds
- 2 tablespoons poppy seeds
- Homestyle tomato chutney, to serve

1. In a large bowl mix together all of the ingredients.
2. Divide mixture in 8 and spoon mixture into the palm of your wet hand and roll together forming a pattie. Flatten slightly.
3. Place onto a plate, cover and refrigerate until required. Make (8) patties.
4. Pre-heat grill plates for 3-5 minutes. Spray grill plates with cooking spray and cook patties (4) at a time for 5-10 minutes or until crispy and golden.
5. Serve patties hot with a chunky homestyle tomato chutney.

### Recipe suggestion:

- Serve patties on wholemeal seeded buns with baby rocket and spinach leaves and grilled onion.

## Antipasto Vegetables

**Serves 4**

To make a decent sized platter for entertaining you will require approx 1.5kg variable vegetables. Here is list of vegetable suggestions for your antipasto platter;

- 1 bunch asparagus, trimmed
- 1 bunch spring onions, tops trimmed and cut to 10cm lengths, cut bulbs in half
- 1 small eggplant, cut into thin slices
- 1 small orange sweet potato, peeled and cut thinly into slices
- 2 small potatoes (kipler or pink fir apple), cut thinly into slices
- 1 zucchini, sliced
- 1 red capsicum, sliced
- 4 field mushrooms, cleaned
- ¼ cup extra virgin olive oil
- Sea salt and black pepper

1. Preheat grill for 3-5 minutes. Spray grill plates with cooking spray.
2. Grill vegetables in batches. When tender remove from grill and wrap in foil.
3. Drizzle in olive oil and sprinkle in salt and pepper. When vegetables are cold serve on a platter with a selection of cold deli meats, cheeses and a variety of breads.

## Contact Grill Recipes continued

### **Potatoes with sour cream and sweet chilli sauce**

**Serves 4**

- 1kg kipfler potatoes
- 1 tablespoon oil
- 2 teaspoons sea salt
- freshly ground pepper
- 1/3 cup sweet chilli sauce
- 1 cup light sour cream

1. Preheat grill for 3-5 minutes. Cut potatoes in half lengthways. Place potatoes in a bowl and toss with the oil, salt and pepper.
2. Cook in your Contact Health Grill for approx. 10 minutes or until the potatoes are tender.
3. Serve with sweet chilli sauce and light sour cream.

### **Barbecue Chilli Lime Prawns**

**Serves 4**

- 1 kg green prawns
- 1/2 teaspoon sugar
- 1 tablespoon peanut oil
- 1 teaspoon grated lime rind
- 1/3 cup lime juice
- 2 red chillies, seeded and finely chopped
- 2 tablespoons sweet chilli sauce
- 1 tablespoon chopped fresh coriander

1. Shell and devein prawns leaving tails intact. Combine prawns and remaining ingredients in a bowl and refrigerate for 1 hour.
2. Preheat grill for 3-5 minutes. Cook prawns for about 2 minutes or until prawns change colour.
3. Serve with steamed jasmine rice.

### **Grilled Mushrooms with Herb Butter** **Serves 4**

- 100g butter
- 1 clove garlic, crushed
- 1 tablespoon seeded mustard
- 1 tablespoon chopped basil
- 1 tablespoon chopped parsley
- sea salt and freshly ground pepper
- 4 large flat mushrooms

1. Combine the butter, garlic, mustard and herbs in a small saucepan, cook over a low heat until the butter has melted and the mixture has combined.
2. Preheat the grill for 3-5 minutes. Cook mushrooms in the Contact Health Grill for about 5-8 minutes or until cooked as desired.
3. Serve mushrooms topped with the herb butter.

### **Grilled swordfish**

**Serves 4**

- 4 pieces swordfish

#### **Dressing**

- 2 cloves garlic, crushed
- 1/3 cup white vinegar
- 1/3 cup olive oil
- 1/4 cup shredded basil leaves

#### **Salad**

- 250g baby rocket
- 100g semi dried tomatoes
- 150g fetta cheese
- 100g kalamata olives

1. Place swordfish in a large dish and pour over two thirds of the combined dressing ingredients. Cover and refrigerate for 1 hour.
2. Preheat grill for 3-5 minutes. Cook swordfish for about 6 minutes or until cooked as desired.

## Contact Grill Recipes continued

3. Serve swordfish over salad and drizzle with remaining dressing.

### **Grilled Vegetable Salad with Haloumi Serves 4**

- 1 red capsicum
- 1 yellow capsicum
- 2 zucchini
- 2 baby eggplant
- 200g haloumi cheese, sliced
- 200g baby rocket
- 1 red onion, sliced

#### **Dressing**

- 1 tablespoon red wine vinegar
- 3 tablespoons extra virgin olive oil
- 1 teaspoon caster sugar
- 1 teaspoon Dijon mustard
- 1 teaspoon sea salt

1. Preheat grill for 3-5 minutes. Cut the capsicums into quarters and discard seeds and membranes. Spray, grill plates with a little cooking spray.
2. Place the capsicums onto the grill plate and cook until the skin has blackened.
3. Remove from contact grill and place into a plastic bag for 5-10 minutes. Once cool, remove skin from capsicum and slice into thick slices.
4. Meanwhile slice the zucchini and eggplants into thin strips and cook in the grill until tender. Remove from heat and allow too cool.
5. Grill the haloumi in the grill plate for about 1 minute or until heated through.

6. Combine the dressing ingredients in a jar and shake well; pour over the grilled vegetables, baby rocket and red onion, toss to combine.

7. Divide salad onto 4 plates and top with haloumi cheese

### **Grilled Vegetable Kebabs Serves 4**

- 4 yellow squash, halved
- 1 large zucchini, thickly sliced
- 1 red capsicum, cut into 2.5cm pieces
- 1 green capsicum, cut into 2.5cm pieces
- 1 red onion, cut into wedges
- 4 cherry tomatoes

#### **Herb and Garlic Marinade**

- ¼ cup finely chopped parsley
- 2 tablespoons finely chopped mint
- 2 cloves garlic, crushed
- 1 fresh chilli, seeded, chopped finely
- ⅓ cup tomato juice
- 1 teaspoon grated lemon rind
- 2 tablespoons lemon juice
- 1¼ tablespoons olive oil
- 1 teaspoon Dijon mustard

1. Divide vegetables evenly onto 4 large or 8 small wooden skewers. Place skewers into a deep dish
2. Combine marinade ingredients in a jug and pour over vegetable kebabs. Refrigerate for 1 hour or overnight.
3. Preheat grill for 3-5 minutes. Place skewers in grill and cook for about 5 minutes or until cooked as desired.

# Contact Grill Recipes continued

## **MARINADES**

Here are two marinades that can be used to flavour and tenderise 500g meat (beef, lamb, pork, poultry and seafood).

### **Island Style Marinade**

- ½ cup hoisin sauce
- ¼ cup tomato sauce
- 2 tablespoons honey
- 2 tablespoons soy sauce
- ¼ teaspoon cracked black pepper
- 2 tablespoons chopped chives
- 1 red chilli, chopped (optional)

### **Italian Style Marinade**

- ½ cup white wine
  - 2 tablespoons olive oil
  - ¼ cup lemon juice
  - 1 tablespoon dry mixed herbs
  - 1 garlic clove, peeled and sliced
1. Combine all marinade ingredients together in a bowl, mix well.
  2. Add meat to marinade, cover and refrigerate for 1-2 hours or overnight. Drain marinade well before grilling.
  3. Heat reserved marinade in a pan until simmering for 1-2 minutes.
  4. Serve over grilled food.

'Sunbeam', is a registered trademark of Sunbeam Corporation. Sunbeam Contact Health Grill is a trademark of Sunbeam Corporation.

Made in China. Due to minor changes in design or otherwise, the product may differ from the one shown in this leaflet. Backed by Sunbeam's 12 Month Replacement Guarantee and National Service Network.

**© Copyright. SUNBEAM CORPORATION LIMITED 2003.**

(INCORPORATED IN N.S.W.) A.C.N. 000 006 771

Sunbeam Corporation is a division of GUD Holdings Ltd.

For more information or advice on this or any other Sunbeam appliance, visit [www.sunbeam.com.au](http://www.sunbeam.com.au) or contact the Sunbeam Consumer Service Line.

**Australia 1800 025 059**

**New Zealand 0800 786 232.**



## Consumer Hotline

Australia

1800 025 059

New Zealand

0800 786 232

[www.sunbeam.com.au](http://www.sunbeam.com.au)

 is a registered Trademark of Sunbeam Corporation Limited. ACN 000 006 771.

© Sunbeam Corporation Limited 2004.