



Service Manual

Washing machine

Frontloader

FL243

Model Version		Page
FL243 8570 759 10200		
	Technical data	2
	Spare part list	3
	Exploded view	4 - 5
	Wiring diagram	6 - 7
	Circuit diagram	8 - 9
	Program diagram	10 - 11

Technical data**Dimensions**

Height	85	cm
Width	59.5	cm
Depth	54	cm

Weight

Net weight	71	kg
With package	74	kg

General specifications

Voltage	230± 10%	V
Frequency	50	Hz
Connected load	~ 2.3	kW
Fuse	10	A

Drum data**Drum speed**

Washing	55	rpm
Spinning	500	rpm

Capacity

Volume	42	l
Max. load dry laundry	5	kg

Electrical building parts**Heating**

Type	Tubular radiator	
Rated power draft	2.05	kW
Mains Voltage	230	V

Drain pump

Power consumption	~ 40	W
Capacity	20	l/min.
Rotation speed	~ 3000	rpm
Height of drain hose	max. 1.00	m
	min. 0.55	m

Motor

Type	Asynchronous 2/16
------	-------------------

Capacitor

Capacity	16	μ F
----------	----	-----

Timer

Type	ELBI S 5000
------	-------------

The timer chart includes

2 basic programmes

- normal washing
- delicate washing & wool

Thermostat

TH - a capillary thermostat	35-80	°C
B - a fixed thermostat	35	°C

Pressostat (without laundry)

Low level	9 ± 1	l
High level	22	l
Safety level	40	l

Push button switch

Version with 4 buttons:

- On / Off	2	pol.
- Half load (LLS)	1	pol.
- Spin execution (SDS)	1	pol.
- Rinse stop(RSS)	1	pol.

Spare part list

Model FL 243
Service No. 857075910200
Version 857075910200

Pos. No.	12NC Code	Description
001 0	4819 440 19894	Cabinet
011 0	4819 310 38995	Foot
021 0	4812 440 19481	Front,panel
024 0	4819 440 19897	Panel, rear
025 0	4819 440 19898	Holder control
030 0	4819 440 19928	Table top
034 2	4819 492 68458	Fastener
034 3	4819 532 68243	Bushing
040 0	4819 417 19232	Hinge
053 0	4819 440 19901	Plinth
061 0	4819 466 89453	Counter weight ,top
061 1	4819 466 89454	Counter weight ,bottom
080 0	4819 492 38058	Spring
081 0	4819 466 48115	Friction plate
083 1	4819 462 38925	Friction plate
084 0	4819 462 48049	Silent bloc
086 0	4819 401 18607	Clamp bushing
110 0	4819 498 78444	Handle
130 0	4819 417 38117	Lock
130 1	4819 535 38062	Shaft Hooh
141 0	4819 450 69806	Door glass
143 0	4812 450 58154	Door cpl.
143 1	4819 459 48914	Glassdoor frame WH
144 0	4819 532 28288	Frame,door glas
144 1	4819 466 89077	Plate door frame
190 0	4819 468 18344	Door bellow
190 1	4819 492 38119	Strap porthole seal
190 2	4819 492 68515	Strap porthole seal
200 0	4819 418 18371	Tub
201 0	4812 464 48113	Bottom Tub
201 1	4819 532 88052	Ring
201 2	4812 464 48111	Bottom
210 0	4819 535 78164	Crosspiece
220 0	4819 418 18291	Drum
220 1	4819 418 18367	Drum , cpl.
228 0	4812 418 18212	Plate
271 0	4819 358 18115	Belt
272 0	4819 528 88119	Pulley
292 0	4819 466 69797	Gasket
301 0	4819 453 28295	Control panel FL 243
331 0	4819 412 58814	Knob,timer
332 0	4812 410 28653	Push button
335 0	4819 412 58815	Knob thermostat WH
339 0	4819 413 28037	Adapter
339 1	4812 413 18198	Adapter Button
351 0	4819 134 48531	Pilot lamp
401 0	4819 361 58276	Motor
401 1	4812 362 48432	Bushing UNI 1743
401 2	4812 404 68025	Silent bloc
420 0	4819 121 18314	Capacitor
421 0	4812 121 18142	Interf.filter 1,00 uF
430 0	4819 360 18189	Pump,draining
451 0	4819 259 28932	Heating element
490 0	4819 321 18136	Cable,mains 2m
491 0	4812 321 28367	Strain relief

Pos. No.	12NC Code	Description
501 0	4819 282 18773	Timer S 5000 4CH
551 3	4819 282 28713	Thermostat
554 0	4819 271 29081	Thermostat 30-80 °C
573 0	4819 281 28236	Valve,magnet
583 0	4819 271 29082	Pressostat
620 0	4819 410 29125	Switch
621 0	4819 410 29126	Switch
630 0	4819 276 18416	Door lock
701 0	4819 530 29034	Hose, inlet
702 0	4819 530 28793	Hose inside
702 1	4819 530 28717	Hose
708 1	4819 530 28868	Drainhose inner
711 0	4819 418 18368	Dispenser
712 0	4819 418 79854	Drawer
718 1	4819 530 29044	Siphon
753 1	4819 418 68234	Chamber,air
754 0	4819 526 48255	Drainhose inner Tub/Pump
781 0	4819 530 29035	Hose,draining
783 0	4819 530 29036	Hose pressostat
787 0	4819 530 28904	Hose,deaeration
794 5	4812 530 58098	Gasket Airtrap
900 0	4812 255 18205	Holder Pressostat
901 0	4819 401 18529	Hose,clamp
901 1	4819 401 18174	Clamp,hose 25-45 mm
901 3	4819 401 18882	Clamp
901 6	4819 401 18436	Clamp,hose
902 1	4812 255 18204	Holder Hose outlet
910 6	4819 502 38005	Screw
912 2	4819 310 38685	Set screw
914 0	4819 505 18376	Nut
931 0	4819 492 38138	Spring,suspens.
932 0	4819 492 68666	Spring
941 0	4819 520 18042	Bearing,ball 6202-2Z
941 1	4819 520 18041	Bearing,ball 6203-2Z
951 0	4819 468 18343	Shaft seal
952 0	4819 466 69882	Gasket thermostat
990 0	4819 310 39124	Mounting kit ,weight top
990 1	4819 310 38684	Mounting kit ,weight bottom
990 2	4819 310 39099	Accessories crosspiece

Exploded view

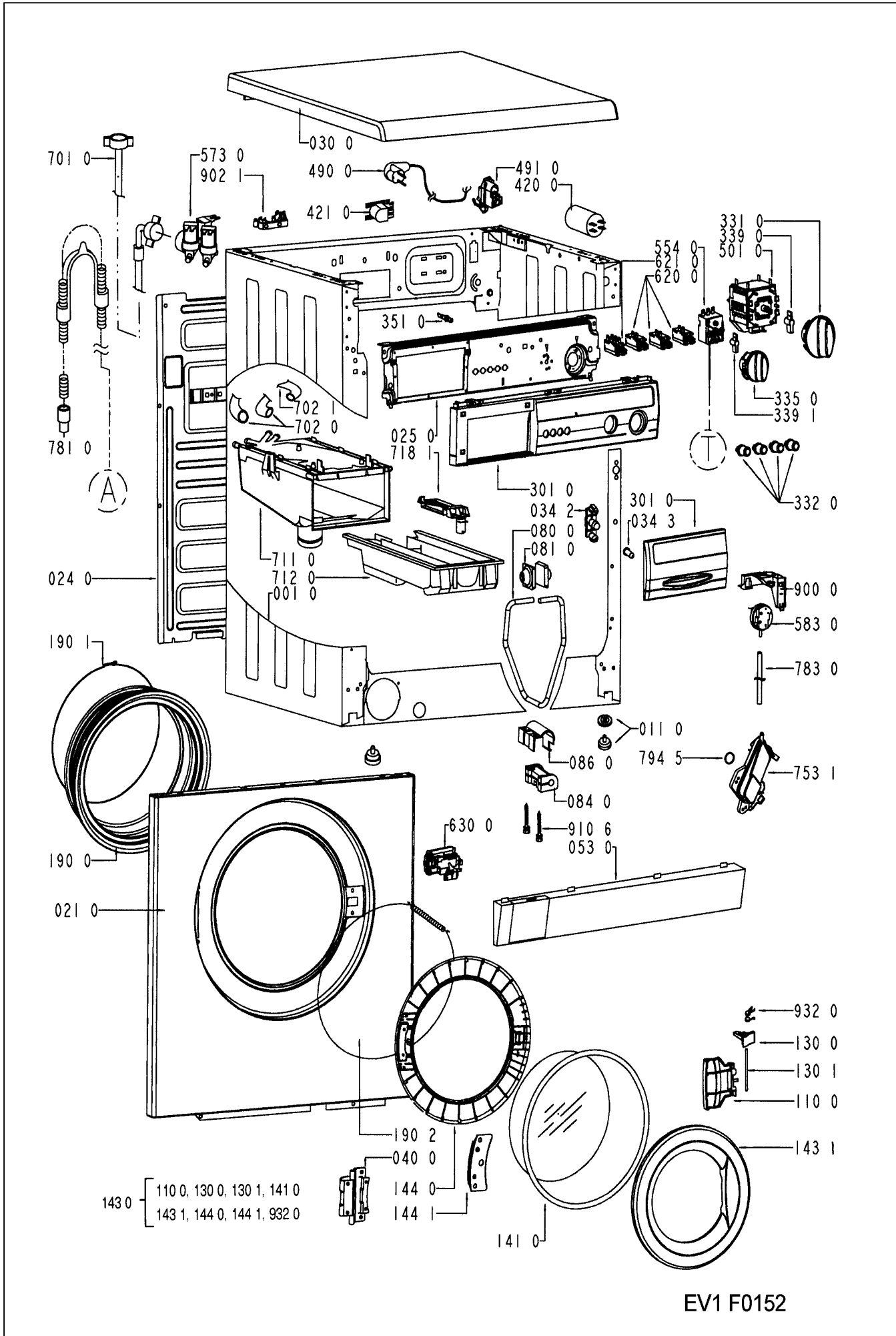

Exploded view

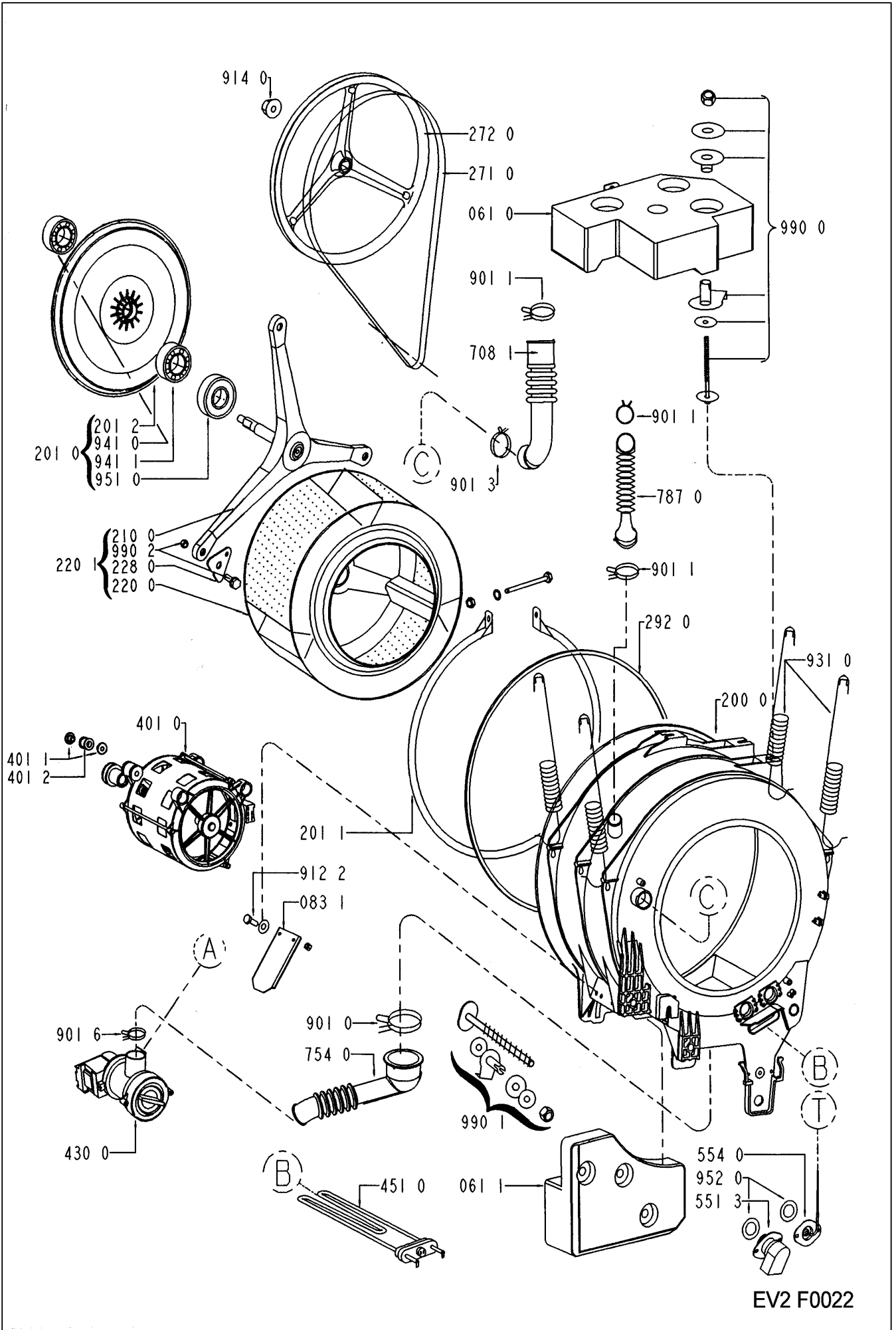

Wiring diagram

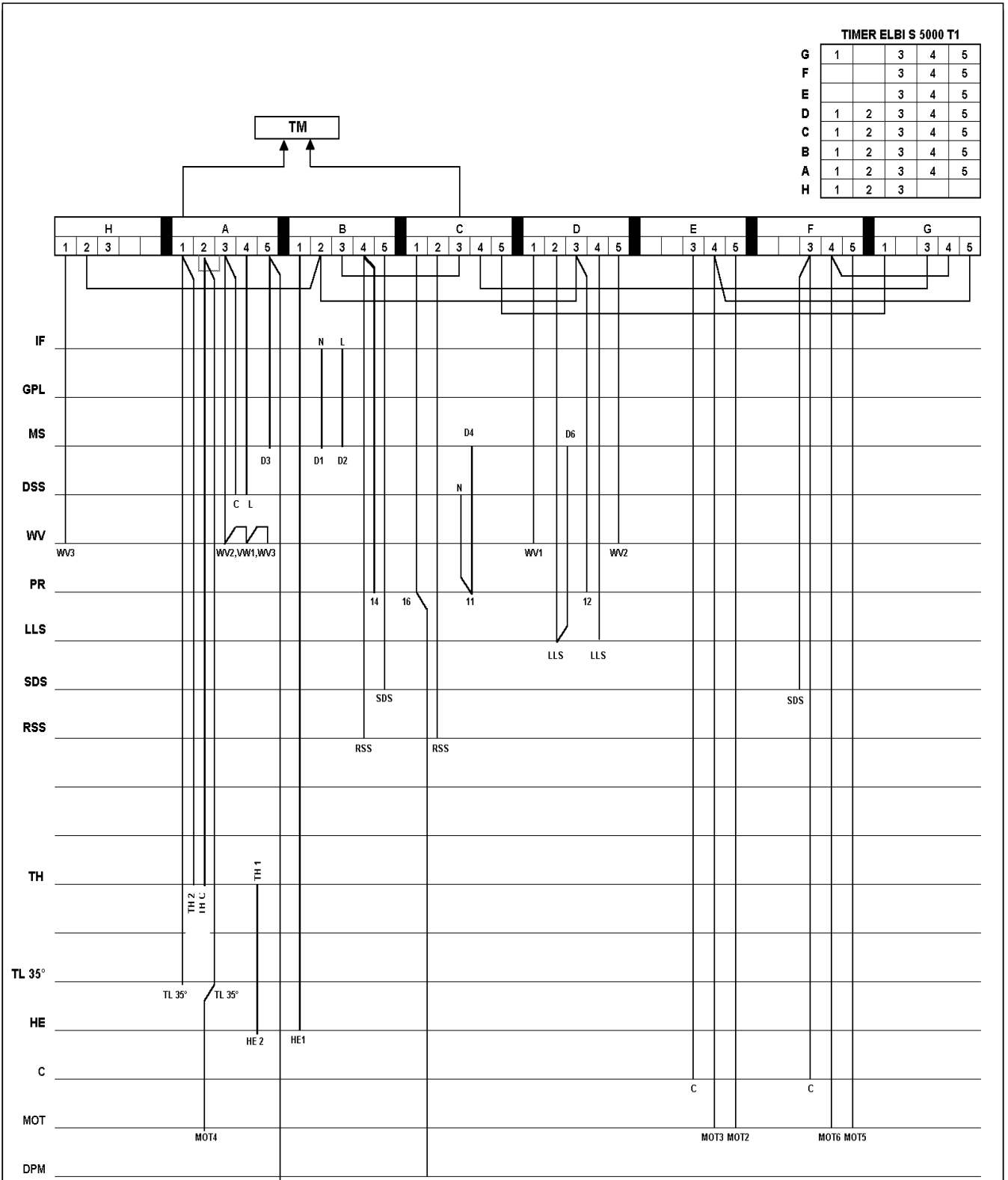

TIMER ELBI S 5000 T1

G	1	3	4	5	
F		3	4	5	
E		3	4	5	
D	1	2	3	4	5
C	1	2	3	4	5
B	1	2	3	4	5
A	1	2	3	4	5
H	1	2	3		

- IF - Interference capacitor
- GPL - Pilot lamp
- MS - Main switch
- DSS - Door lock switch
- WV - Inlet water valve
- PR - Pressostat
- LLS - Half load switch
- SDS - Spin stop switch
- RSS - Rinse hold switch
- TH - Capillary thermostat
- TL 35° - Thermostat 35°C
- HE - Heating element
- C - Capacitor
- M - Motor
- DPM - Draining pump motor
- TM - Timer motor

409M4 -509M4 - 609M4

Wiring diagram

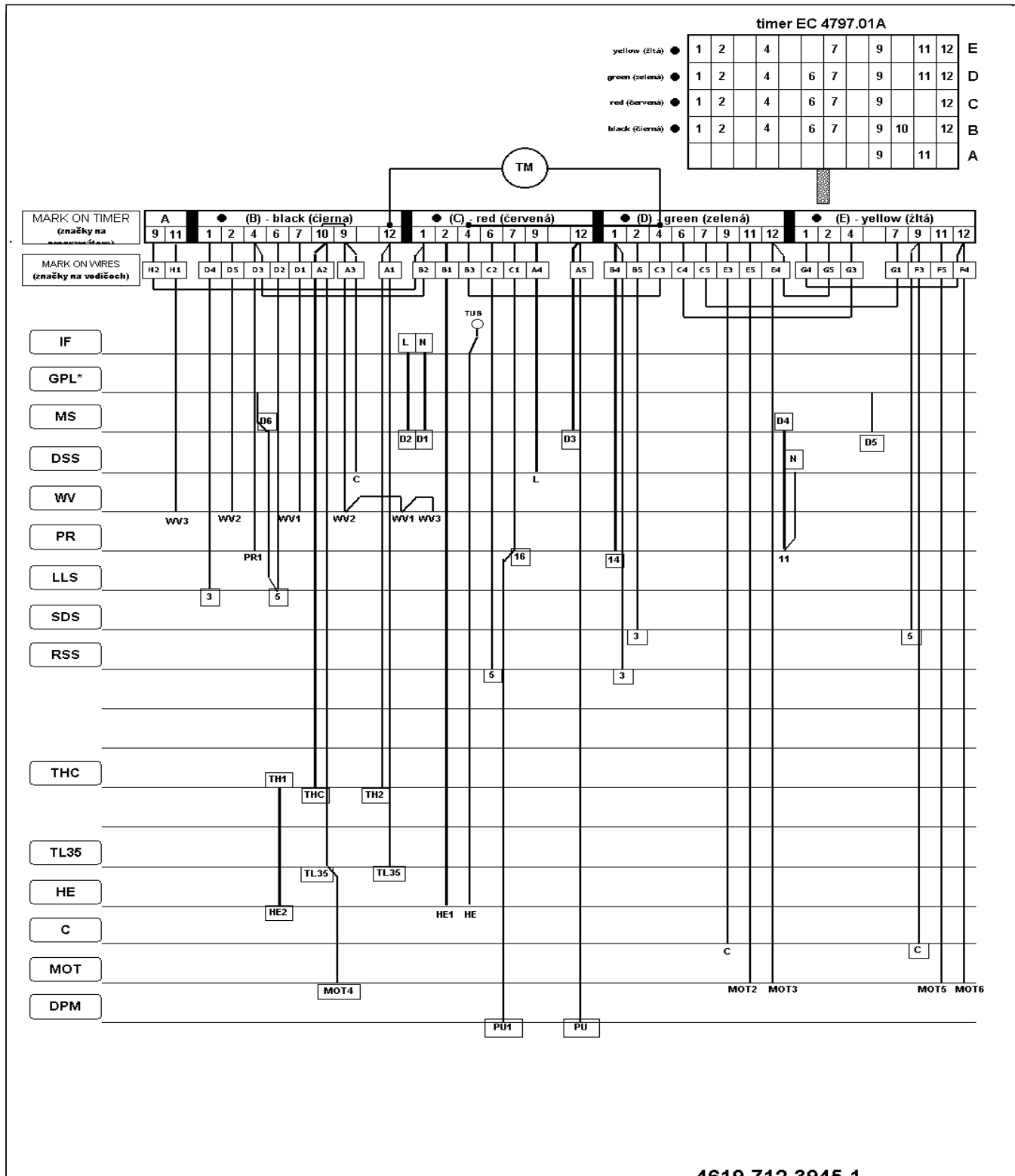

LEGEND (legenda) :

- IF - Interference capacitor (odrušovací kondenzátor)
- MS - Main switch (tlačidlo O/I)
- DSS - Door lock switch (el. zámok)
- WV - Inlet water valve (napúšťací ventil)
- PR - Pressostat (hladinový spínač)
- LLS - Half load switch (tlačidlo 1/2 náplň)
- SDS - Spin stop switch (tlačidlo stop odstreďovania)
- RSS - Rinse hold switch (tlačidlo stop plákania)
- GPL* - Pilot lamp (* optional) (signálka O/I - *voliteľné)

- THC - Capillary thermostat (kapilárny termostat)
- TL 35°. Thermostat 35°C (termostat 35 °C)
- HE - Heating element (ohrievacie teleso)
- C - Capacitor (rozbeňový kondenzátor)
- MOT - Motor
- DPM - Draining pump motor (motor čerpadla)
- TM - Timer motor (motorček programátora)

Circuit diagram

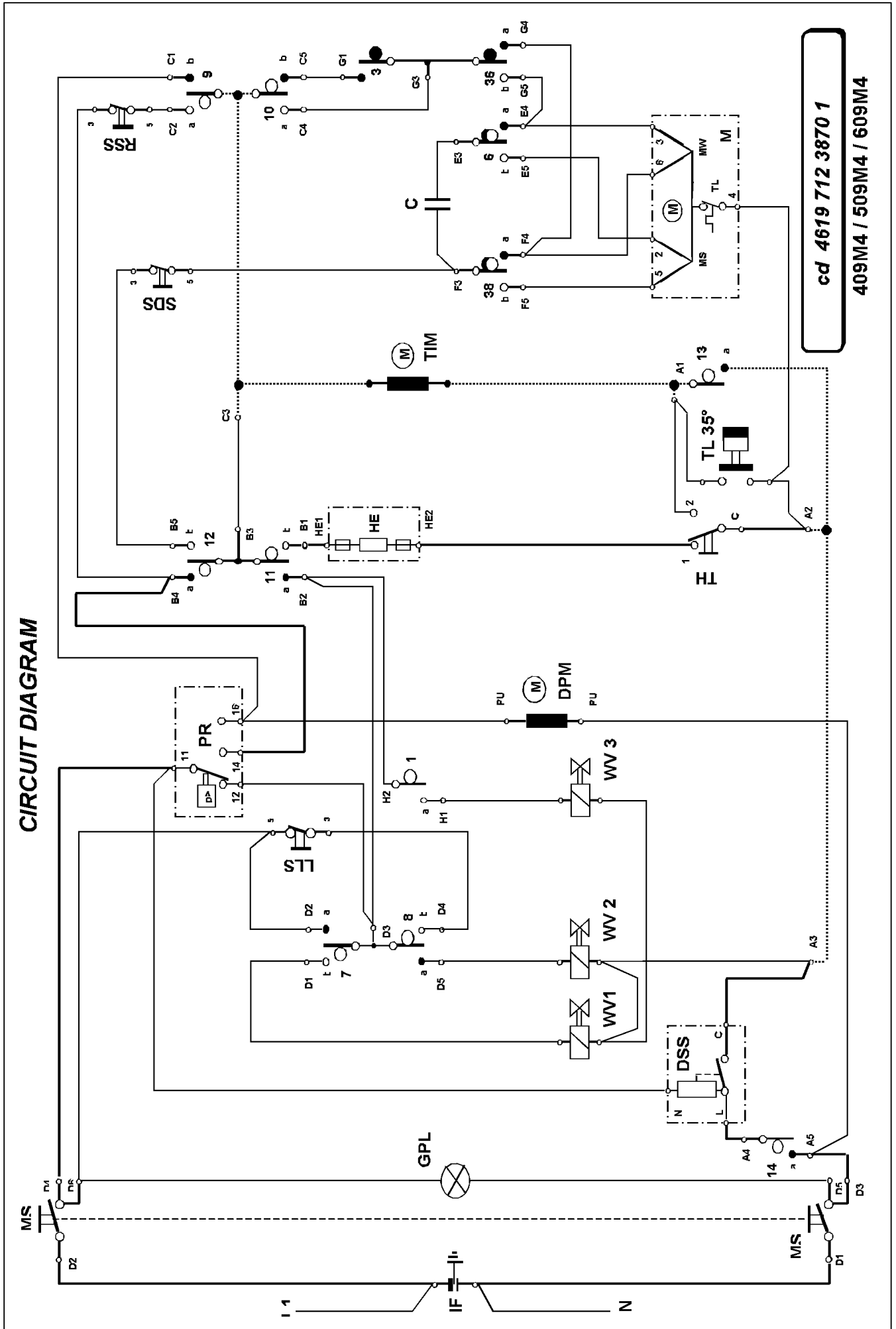

Circuit diagram

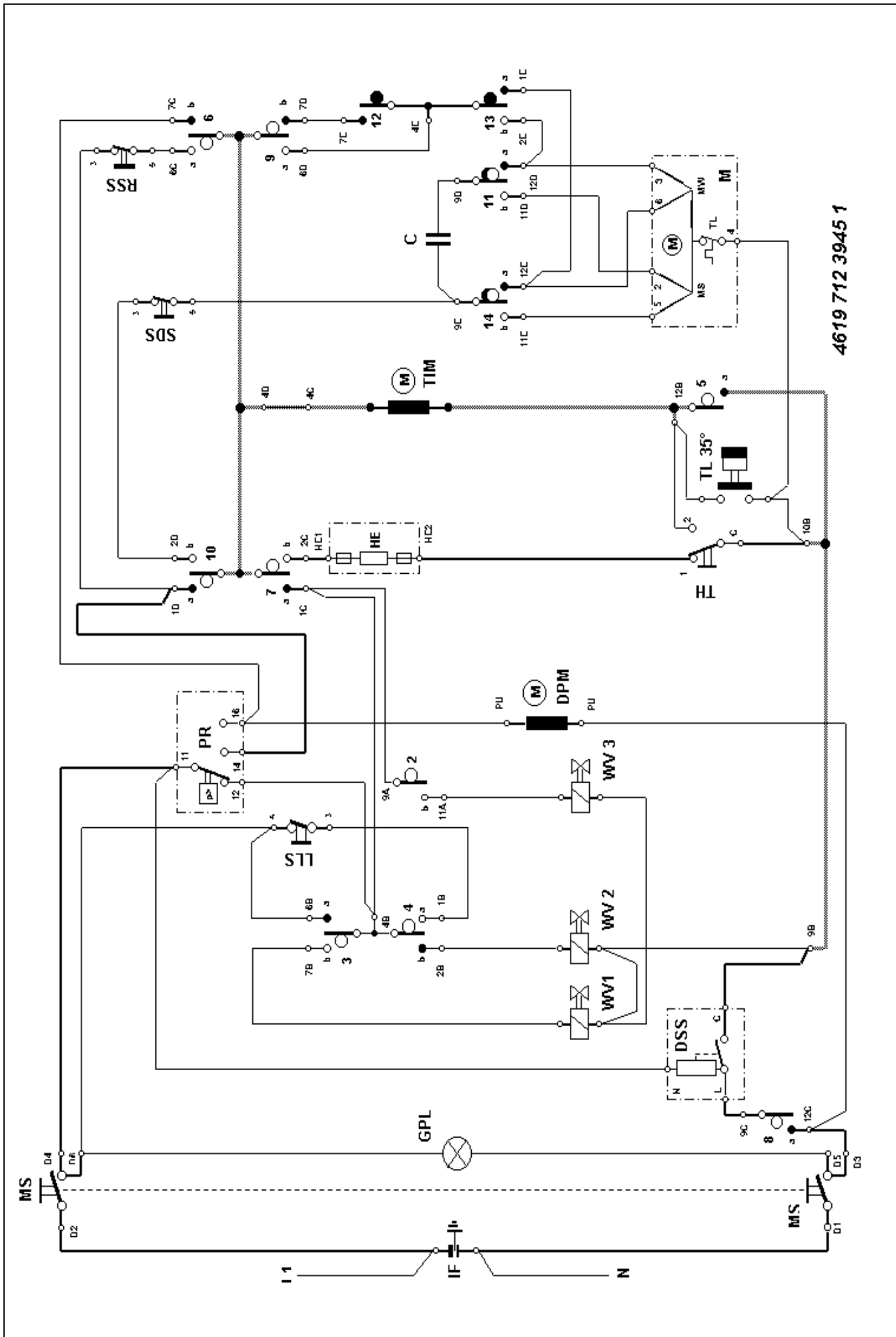

Program diagram

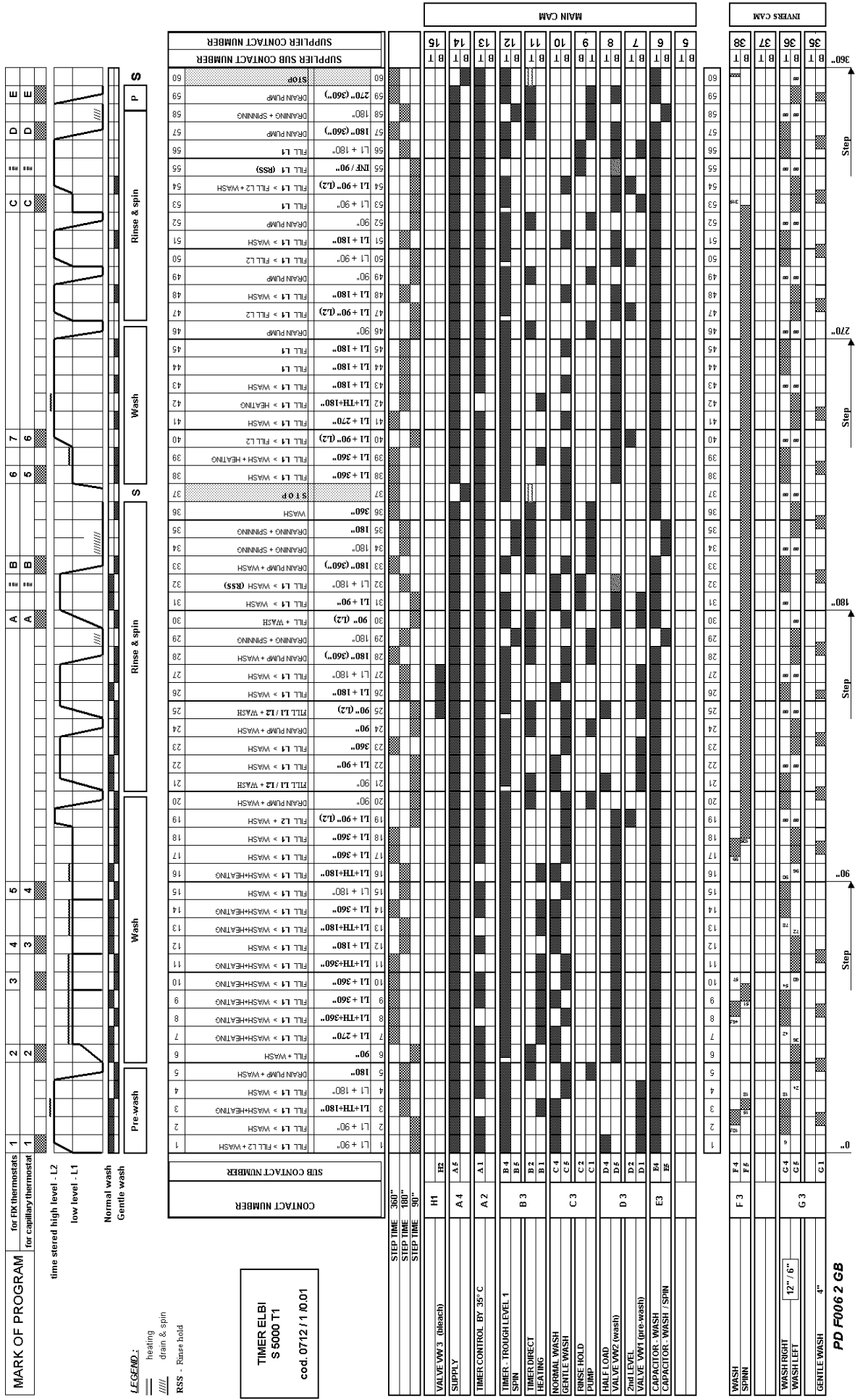

4619 712 3895 2

PD F006 2 GB

Program diagram

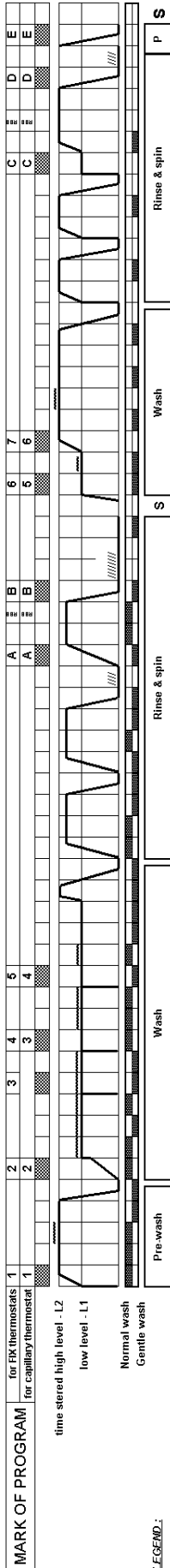

CONTACT NUMBER	SUB CONTACT NUMBER	SUPPLIER SUB CONTACT NUMBER
1	L1 + 84"	FILL L1 > FILL L2 + WASH
2	L1 + 96"	FILL L1 > WASH
3	L1+TH+180"	FILL L1 > WASH+HEATING
4	L1 + 180"	FILL L1 > WASH
5	180"	DRAIN PUMP + WASH
6	84"	FILL + WASH
7	L1 + 276"	FILL L1 > WASH+HEATING
8	L1+TH+360"	FILL L1 > WASH+HEATING
9	L1 + 360"	FILL L1 > WASH+HEATING
10	L1 + 360"	FILL L1 > WASH+HEATING
11	L1+TH+360"	FILL L1 > WASH+HEATING
12	L1 + 180"	FILL L1 > WASH
13	L1 + 180"	FILL L1 > WASH
14	L1 + 360"	FILL L1 > WASH+HEATING
15	L1 + 180"	FILL L1 > WASH
16	L1+TH+180"	FILL L1 > WASH+HEATING
17	L1 + 360"	FILL L1 > WASH
18	L1 + 360"	FILL L1 > WASH
19	L1 + 84" (L2)	FILL L2 > WASH
20	96" (L2)	FILL + WASH
21	84" (L2)	FILL + WASH
22	L1 + 96"	FILL L1 > WASH
23	L1 + 360"	FILL L1 > WASH
24	84"	DRAIN PUMP + WASH
25	96" (L2)	FILL + WASH
26	L1 + 180"	FILL L1 > WASH
27	L1 + 180"	FILL L1 > WASH
28	180"	DRAIN PUMP + WASH
29	180"	DRAINING + SPINNING
30	84" (L2)	FILL + WASH
31	L1 + 96"	FILL L1 > WASH
32	180"	WASH (RSS)
33	180" (360")	DRAIN PUMP + WASH
34	180"	DRAINING + SPINNING
35	180"	DRAINING + SPINNING
36	360"	WASH
37	STOP	STOP
38	L1 + 360"	FILL L1 > WASH
39	L1 + 360"	FILL L1 > WASH + HEATING
40	L1 + 84" (L2)	FILL L1 > FILL L2
41	L1 + 276"	FILL L1 > WASH
42	L1+TH+180"	FILL L1 > HEATING
43	L1 + 180"	FILL L1 > WASH
44	L1 + 180"	FILL L1
45	L1 + 180"	FILL L1
46	84"	DRAIN PUMP
47	L1 + 96" (L2)	FILL L1 > FILL L2
48	L1 + 180"	FILL L1 > WASH
49	84"	DRAIN PUMP
50	L1 + 96"	FILL L1 > FILL L2
51	L1 + 180"	FILL L1 > WASH
52	84"	DRAIN PUMP
53	L1 + 96"	FILL L1
54	L1 + 84" (L2)	FILL L1 > FILL L2 + WASH
55	INF / 96"	(RSS)
56	L1 + 96" (180)	FILL L1
57	180" (360)	DRAIN PUMP
58	180"	DRAINING + SPINNING
59	180" (360)	DRAIN PUMP
60	STOP	STOP

STEP TIME	360"	180"	90"
VALVE VM3 (bleich)	9A		
VALVE VM1 (pre-wash)	7		
2nd LEVEL	6		
VALVE VM2 (wash)	2		
HALF LOAD	1		
TIMER CONTROL BY 35°C	9B/10B		
PUMP	7		
RINSE HOLD	6		
HEATING	2		
TIMER DIRECT	1		
SUPPLY	11		
GENTLE WASH	12		
NORMAL WASH	7		
SPIN	6		
TIMER - TROUGH LEVEL 1	2		
CAPACITOR - WASH / SPIN	11		
CAPACITOR - WASH	12		

CONTACT NUMBER	SUB CONTACT NUMBER	SUPPLIER SUB CONTACT NUMBER
1	11	90
2	12	90
3	11	90
4	12	90
5	11	90
6	12	90
7	11	90
8	12	90
9	11	90
10	12	90
11	11	90
12	12	90
13	11	90
14	12	90
15	11	90
16	12	90
17	11	90
18	12	90
19	11	90
20	12	90
21	11	90
22	12	90
23	11	90
24	12	90
25	11	90
26	12	90
27	11	90
28	12	90
29	11	90
30	12	90
31	11	90
32	12	90
33	11	90
34	12	90
35	11	90
36	12	90
37	11	90
38	12	90
39	11	90
40	12	90
41	11	90
42	12	90
43	11	90
44	12	90
45	11	90
46	12	90
47	11	90
48	12	90
49	11	90
50	12	90
51	11	90
52	12	90
53	11	90
54	12	90
55	11	90
56	12	90
57	11	90
58	12	90
59	11	90
60	12	90

CONTACT NUMBER	SUB CONTACT NUMBER	SUPPLIER SUB CONTACT NUMBER
1	11	90
2	12	90
3	11	90
4	12	90
5	11	90
6	12	90
7	11	90
8	12	90
9	11	90
10	12	90
11	11	90
12	12	90

4619 712 3929 1

PD F008 1 GB