

## PRESSURE ZONE MICROPHONE



The Crown<sup>®</sup> PZM<sup>®</sup>-11LLWR is a weather-resistant Pressure Zone Microphone<sup>®</sup> with a balanced, line-level output. A plastic membrane inside the microphone protects the mic capsule from water damage. The mic mounts in a standard electrical outlet box. Applications include fast-food restaurants, outdoor intercoms, toll booths, bridges, theme park security, home automation, and so on.

The microphone can be plugged directly into a VCR line input — no costly mic preamp is needed. Output (via screw terminals) can be balanced or unbalanced. Powering is by 12-24V AC or DC. **The unit can be factory-set for phantom powering by special order, as a PZM-11LLWRS1.**

In the PZM-11LLWR, frequencies below the voice range are rolled off to reduce traffic rumble. The high-frequency response is boosted to help articulation. Because of its tailored response and PZM construction, the PZM-11LLWR will pick up conversations or other desired sounds with extra clarity.

The unit is “weather resistant,” which means:

- The microphone will work during and after rainfall.
- The mic’s frequency response will change temporarily if the membrane gets wet, but will return to normal when dry.
- If water freezes on the membrane, the mic’s frequency response will change, but will return to normal when the ice melts and the membrane dries.
- High-pressure water sprays directly on the membrane (through the louvered wall plate) may damage the membrane.
- The microphone is not designed to be submerged.

### Installation

1. Please refer to Figure 3 and locate all the parts shown. The electrical outlet box and cables are not included.
2. Run a 2-conductor shielded cable to the surface where you intend to install the microphone. Install a standard electrical outlet box there (2-inch minimum depth).
3. The PZM-11LLWR can be powered by 12-24V AC or DC.

From your power source, run a twisted pair power cable to the mic location. Run the power cable through the hole in the electrical box. Service the end of the power cable.

### Features

- Ideal for outdoor security, surveillance and intercoms
- Weather-resistant
- Line-level output connects directly to video recorders
- Clear, articulate sound
- Inconspicuous

### Specifications

**Transducer type:** Electret condenser.

**Frequency response (typical):** 80 Hz to 10,000 Hz (see Fig. 1).

**Polar pattern:** Hemispherical.

**Impedance:** 75 ohms, balanced. Recommended minimum load impedance 1000 ohms.

**Open-circuit sensitivity, typical:** 1.4 V/Pa.

**Power sensitivity, typical:** +8 dBm/Pa.

**Equivalent noise level (self-noise):** 26 dB SPL typical (0 dB = .0002 dyne/cm<sup>2</sup>), A-weighted.

**S/N Ratio:** 68 dB at 94 dB SPL.

**Maximum SPL:** 100 dB SPL produces 3% THD at maximum gain.

**Operating voltage:** 12-24V AC or DC. Phantom powering by special order as a PZM-11LLWRS1.

**Polarity:** Positive pressure on diaphragm produces positive voltage on audio+ terminal with respect to audio- terminal

**Current drain:** 4 milliamperes.

**Operating temperature range:** -10° to +60° C, or +14° to +140° F. The mic still works at -40° C but its sensitivity is reduced. When the mic is returned to normal operating temperature, its sensitivity will be within +/-3 dB of normal.

**Output connector:** Screw terminals labeled AUDIO +, AUDIO - and GROUND.

**Cable:** None supplied. Use 2-conductor shielded mic cable and twisted-pair power cable.

**Materials:** Steel plate and high-impact plastic capsule holder. Plastic membrane, part no. 127255-1.

**Finish:** Silver. If you paint the mic, take care not to paint inside the louvered wall plate.

**Net weight:** 2.5 oz. (71 g).

**Dimensions:** 4.530 x 2.780 x 1.722 inches (LWD) (see Fig. 2).

\*1 pascal = 10 dynes/cm<sup>2</sup> = 10 microbars = 94 dB SPL.

Fig. 1

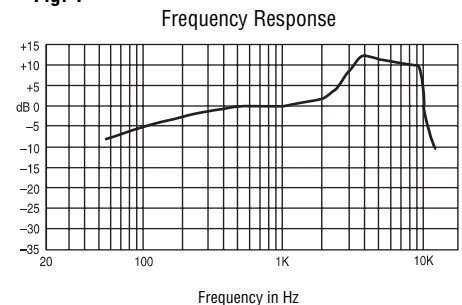
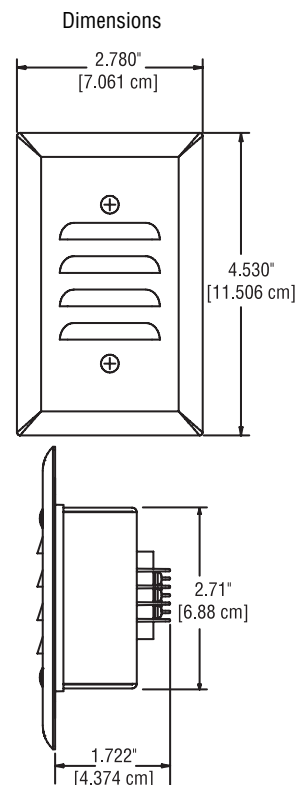

Fig. 2





4. Run the mic cable through the hole in the electrical box. Service the end of the mic cable.

5. Connect the mic cable's audio hot lead to the terminal labeled AUDIO +. Connect the audio cold lead to the terminal labeled AUDIO -. Connect the cable shield to the terminal labeled GROUND.

If you plan to use an RCA or phone connector: Solder the cable shield to the long lug, and solder the AUDIO + lead to the tip or pin. Do not connect the AUDIO - lead because this may reduce the output level in an unbalanced configuration.

6. Attach the power leads to the screw terminals marked "+". You can use 12-24V AC or DC. Polarity does not matter in either case.

7. Using the two shorter screws provided, attach the mic to the electrical box. Then use the other two screws to secure the louvered wall plate to the microphone. Do not remove or damage the plastic membrane.

8. If the mic cable is run in metal conduit, ground loops can occur that can cause hum. If hum is present after installation, return the unit to Crown's service dept. for ground-lift modification.

### Architects' and Engineers' Specifications

The microphone shall be the Crown model PZM-11LLWR or equivalent. It shall be a Pressure Zone Microphone, mountable in a wall or ceiling, and designed not to look like a microphone. It shall have a line-level output (1.4 V/Pa unloaded) and be powered by 12-24V AC or DC, or phantom power. The frequency response shall be from 80 Hz to 10,000 Hz with a low-frequency rolloff to reduce rumble and high-frequency boost for articulation. The audio connector and power connector shall be screw terminals. Output shall be balanced, low impedance. The electret condenser transducer shall have a hemispherical polar pattern when the microphone is mounted in a wall or ceiling. The Crown PZM-11LLWR microphone is specified.

### Warranty

Crown professional microphones are guaranteed against malfunction for a period of three years from date of original purchase. Please refer to the enclosed full warranty statement for more detail.

# PZM-11LLWR

### Service

If the unit fails to work, recheck all your connections as described in the Installation Section. Check the cables. Also check the power supply to verify that it is supplying correct voltage. A Service Return Authorization (SRA) is required for product being sent to the factory for service. An SRA can be completed on line at [www.crownaudio.com/support/factserv.htm](http://www.crownaudio.com/support/factserv.htm). If service is required, return the microphone in its original packaging to: **Crown Factory Service, 1718 West Mishawaka Road, Elkhart, Indiana 46517-9439**. For further assistance or technical support call **800-342-6939**.

Fig. 3

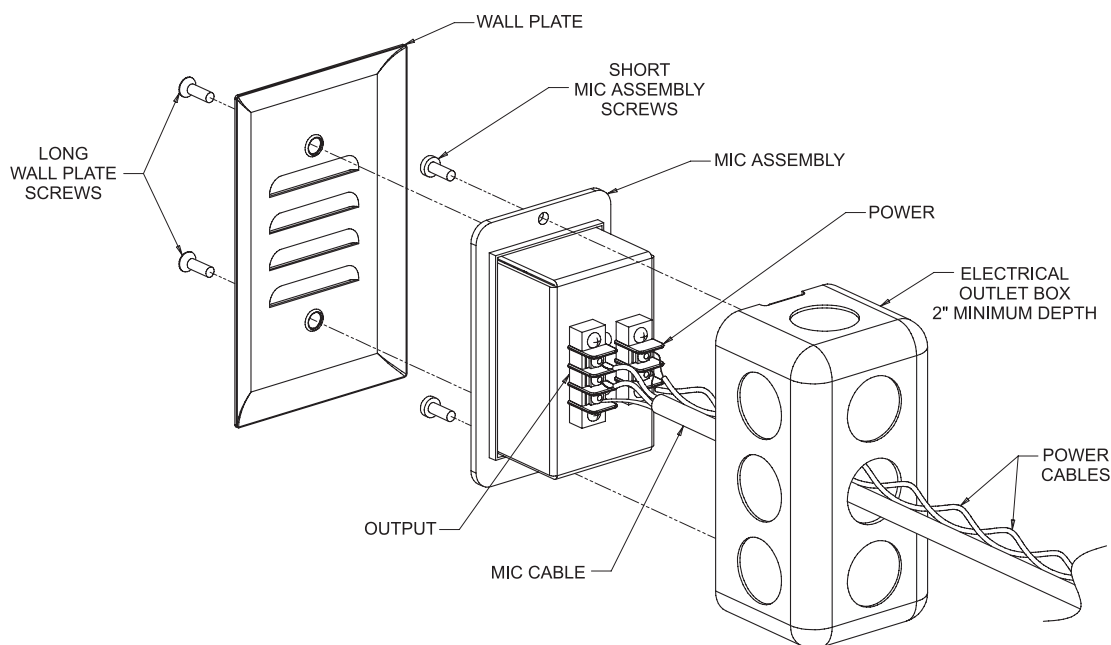

H A Harman International Company

Crown International, Inc.  
1718 W. Mishawaka Rd.  
Elkhart, IN 46517-9439  
TEL: 574-294-8000  
FAX: 574-294-8FAX  
[www.crownaudio.com](http://www.crownaudio.com)

©2008 Crown Audio®, Inc. Specifications subject to change without prior notice. Latest information available at [www.crownaudio.com](http://www.crownaudio.com). Crown, Crown Audio, PZM and Pressure Zone Microphone are registered trademarks of Crown International.