

signa® 5 whirlpool bath and soaking bath

the signa® whirlpool bath takes its name from the medieval central Italian walled city, lastra a signa.



Like the walled city for which it is named, Signa® 5 was specially developed and designed for walled surround spaces.

features:

- Contoured backrest.
- 4 Fully adjustable TheraPro™ jets
- 2 AccuPro™ foot jets.
- Exclusive Tru-Level™ base system.
- Slip-resistant bottom.
- Patented Silent Air™ Induction system.
- Electronic controls
- Drain included on whirlpool baths

signa® 5 whirlpool bath

model number: 6880 – RH pump,
C540 – LH pump

exterior dimensions:
60" long x 42" wide x 22" high

interior dimensions:
41" long x 25" wide

of Jets/type of Jets:
4 TheraPro™ Jets
2 AccuPro™ Foot Jets

operating gallons:
42 gallons

signa® 5 soaking bath

model number: 9625

exterior dimensions:
60" long x 42" wide x 22" high

interior dimensions:
41" long x 25" wide





Signa™ 5 Whirlpool Bath

Model: C540, 6880

Signa™ 5 Bath

Model: 9625

Ordering Information

Product Code:

6880 Signa™ 5 Whirlpool Bath Right Hand

C540 Signa™ 5 Whirlpool Bath Left Hand

9625 Signa™ 5 Bath

- Center Drain Location
- Accessories / Hardware:
 - Trip-Lever Drain Kit #X559
 - Rotary Drain Kit, 26" Cable #8730
 - 4 X HTC Jet Trim Kit: #D095
 - 2 X BMH Jet Trim Kit: #J869
- Trim Kit Finishes Available:
 - (827) - Chrome
 - (898) - Brushed Chrome
 - (815) - Satin Nickel
 - (829) - Bright Brass
 - (805) - Platinum
 - (826) - Brushed Nickel
 - (849) - Oil Rubbed Bronze

Installation Notes

Refer to installation instructions included with fixture before beginning installation. Please confirm product availability and specifications before commencing with any installation work.

PRODUCT SPECIFICATIONS AND AVAILABILITY ARE SUBJECT TO CHANGE WITHOUT NOTICE.

Electrical Components and Electrical Specifications do not apply to non-jetted baths.

Technical Specifications

Dimensions

60" L x 42" W x 22" H
(1524 mm) L x (1067 mm) W x (559 mm) H

Drain/Overflow

A: 17-1/2" (445 mm) B: 12-1/2" (318 mm)

Cutout

58" x 40"

Total Weight

C540, 6880: 708 lb (321 kg) / 40 lb/sq. ft. (197 kg/m²)
9625: 667 lb (303 kg) / 38 lb/sq. ft. (186 kg/m²)

Operating Gallonage

42 U.S. Gal. (159 Liters)
Max. 82 U.S. Gal. (310 Liters)

Product Weight

C540, 6880: 108 lb (49 kg)
9625: 67 lb (30 kg)

Skirt Mounting

Optional, U-Frame

Electrical Specifications Models C540, 6880 only

Requires a dedicated GFCI protected separate circuit.

Motor/Pump: 120 VAC, 15 AMP, 60 Hz.

RapidHeat™: 120 VAC, 15 AMP, 60 Hz.

Heater (Optional) Models C540, 6880 only

Requires a dedicated GFCI protected separate circuit.

RapidHeat™: P/N S750000

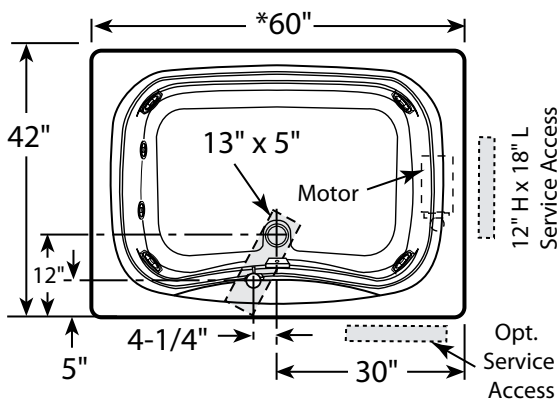

Product Shown: Signa™ 5 Whirlpool Bath Right Hand Model: 6880

* Measurements inside unit represent cutout in floor to allow for drain/overflow.

Minimum Service Access dimensions given.

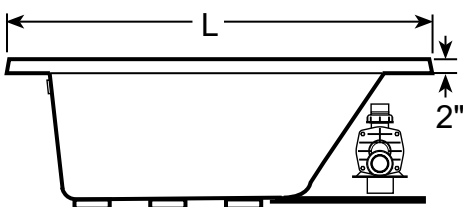

SIDE VIEW

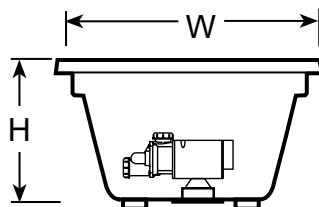

END VIEW

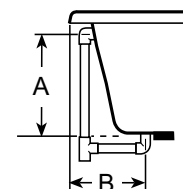

DRAIN/OVERFLOW