

2012

Owner's Manual

United States, Canada, and International

In-ground Spas



www.calspas.com



Cal Spas Home Resort™

© 2011 LMS, Inc.

Preparing for Your New Inground Spa

Inground Spa Installation Checklist	4
Planning the Best Location For Your Spa	4
Planning the Best Place for the Outdoor Equipment Pack	5
Inground Spa Site Preparation	5
Spa Shell Dimensions and Side Views	6
Electrical Requirements – US and Canada	13
GFCI Wiring Diagram	14
Electrical Installation -- Europe	15
RCD Wiring Diagram	16
Installing the Inground Shell	17
Equipment Pack Plumbing Connections . . .	18
Plumbing Connections	18
Electrical and Electronic Connection	20
Pouring the Deck	23

9800 Electronic Control Operation

Diagnostic Messages	27
Adjustable Jets	29

Diverter Knobs	29
--------------------------	----

Clear Water Plan

The Key to Clear Water	30
Testing and Adjusting Spa Water	31
Sanitation	32
Filter Cleaning	33
Bather Load	34
Starting the Spa with Fresh Water	34
Maintenance Schedule	35

Cleaning and Maintenance

Removing and Reseating the Pillows	36
Spa Cover	36
Draining Your Spa	37
Cleaning and Replacing the Filter	37
Winterizing (Cold Climate Draining)	37
Cleaning Your Spa	38

Appendix

Replacement Parts	39
Warranty	39

Copyright 2011 LMS, Inc. All rights reserved. Duplication without written consent is strictly prohibited.

Cal Spas® is a registered trademark.

Due to continuous improvement programs, all models, operation, and/or specifications are subject to change without prior notice.

LTR20121002, Rev. A

12/30/11

100-1074

CONTACT INFORMATION

For customer service, please contact your authorized dealer immediately. If you need additional information and/or assistance, please contact:

LMS Customer Service Department
1462 East Ninth Street
Pomona, CA 91766.

Toll Free: 1-800-CAL-SPAS

Fax: 1-909-629-3890

www.calspas.com

Important Safety Instructions

When installing and using this electrical equipment, always follow basic safety precautions. Following these instructions will help make your first spa session a pleasurable one.

READ AND FOLLOW ALL INSTRUCTIONS

NOTE: A licensed electrician may be required to upgrade your standard receptacle and/or circuit breaker.

DANGER -- RISK OF ACCIDENTAL DROWNING: Do not allow children to be in or around a spa unless a responsible adult supervises them. Keep the spa cover on and locked when not in use. See instructions enclosed with your cover for locking procedures.

DANGER -- RISK OF INJURY: The suction fittings in this spa are sized to match the specific water flow created by the pump. Should the need arise to replace the suction fittings, or the pump, be sure the flow rates are compatible.

DANGER -- RISK OF INJURY: Never operate the spa if the suction fitting or filter baskets are broken or missing.

DANGER -- RISK OF INJURY: Never replace a suction fitting with one that is rated less than the flow rate marked on the original suction fitting.

DANGER -- RISK OF ELECTRIC SHOCK: Install the spa at least five feet (1.5 meters) from all metal surfaces. As an alternative, a spa may be installed within 5 feet of metal surfaces if each metal surface is permanently bonded by a minimum #8 AWG solid copper conductor to the outside of the spa's control box.

DANGER -- RISK OF ELECTRIC SHOCK: Do not permit any external electrical appliances, such as lights, telephones, radios, televisions, and etc., within five feet (1.5 meters) of the spa. Never attempt to operate any electrical device from inside the spa. This does not apply to lights built in to the spa as factory options from Cal Spas™.

WARNING -- RISK OF INJURY

The spa water should never exceed 104°F (40°C). Water temperatures between 100°F (38°C) and

104°F (40°C) are considered safe for a healthy adult. Lower water temperatures are recommended for young children and when spa use exceeds 10 minutes.

High water temperatures have a high potential for causing fetal damage during pregnancy. Women who are pregnant, or who think they are pregnant, should always check with their physician prior to spa usage.

The use of alcohol, drugs or medication before or during spa use may lead to unconsciousness, with the possibility of drowning.

Persons suffering from obesity, a medical history of heart disease, low or high blood pressure, circulatory system problems or diabetes should consult a physician before using the spa.

Persons using medications should consult a physician before using the spa since some medications may induce drowsiness while others may affect heart rate, blood pressure and circulation.

Hyperthermia Danger

Prolonged exposure to hot air or water can induce hyperthermia. Hyperthermia occurs when the internal temperature of the body reaches a level 3°F to 6°F above the normal body temperature of 98.6°F (or 2°C to 4°C above 37°C). While hyperthermia has many health benefits, it is important not to allow your body's core temperature to rise above 103°F (39.5°C). Symptoms of excessive hyperthermia include dizziness, lethargy, drowsiness and fainting. The effects of excessive hyperthermia may include:

- Failure to perceive heat
- Failure to recognize the need to exit spa or hot tub
- Unawareness of impending hazard
- Fetal damage in pregnant women
- Physical inability to exit the spa
- Unconsciousness

WARNING: The use of alcohol, drugs, or medication can greatly increase the risk of fatal hyperthermia.

Preparing for Your New Inground Spa

Most cities and counties require permits for exterior construction and electrical circuits. In addition, some communities have codes requiring residential barriers such as fencing and/or self-closing gates on property to prevent unsupervised access to the property by children. Your dealer can provide information on which permits may be required and how to obtain them prior to the delivery of your Cal Spa.

Inground Spa Installation Checklist

Before Delivery	
	Plan your delivery route
	Choose a suitable location for the shell and equipment pack
	Excavate the hole
	Install dedicated electrical supply
	Install dedicated NG line for gas heater

After Delivery	
	Remove spa from shipping platform
	Install shell in ground
	Install equipment pack
	Connect plumbing
	Connect electrical components
	Pour the deck

Planning the Best Location For Your Spa

Safety First

Do not place your spa within 10 feet (3 m) of overhead power lines.

Make sure the spa is positioned so that access to the equipment compartment and all side panels will not be blocked. Be certain that your installation will meet all city and local safety codes and requirements.

Consider How You Will Use Your Spa

How you intend to use your spa will help you determine where you should position it. For example, will you use your spa for recreational or therapeutic purposes? If your spa is mainly used for family recreation, be sure to leave plenty of room around it for activity. If you will use it for relaxation and therapy, you'll probably want to create a specific mood around it.

Plan for Your Environment

If you live in a region where it snows in the winter or rains frequently, place the spa near a house entry. By doing this, you will have a place to change clothes and not be uncomfortable.

Consider Your Privacy

In a cold-weather climate, bare trees won't provide much privacy. Think of your spa's surroundings during all seasons to determine your best privacy op-

tions. Consider the view of your neighbors as well when you plan the location of your spa.

Provide A View With Your Spa

Think about the direction you will be facing when sitting in your spa. Do you have a special landscaped area in your yard that you find enjoyable? Perhaps there is an area that catches a soothing breeze during the day or a lovely sunset in the evening.

Keep Your Spa Clean

Prevent dirt and contaminants from being tracked into your spa by placing a foot mat at the spa's entrance where the bather's can clean their feet before entering your spa. You may also consider keeping a small water-filled basin nearby for bathers to rinse their feet before entering your spa.

In planning your spa's location, consider a location where the path to and from the house can be kept clean and free of debris.

Allow For Service Access

Many people choose to install a decorative structure around their spa. If you are installing your spa with any type of structure on the outside, such as a gazebo, remember to allow access for service. It is always best to design special installations so that the spa can still be accessed.

Planning the Best Place for the Outdoor Equipment Pack

The Designer Spa series requires an external equipment pack. When locating the outdoor equipment pack, you will want to consider the following:

- The equipment pack must be located within a maximum of 15 feet from the spa.
- Ensure the equipment running its normal filtration cycles does not make too much noise for spa owners and/or neighbors.
- Ensure the equipment can be easily serviced for filter cleaning and periodic inspections in the location chosen.
- If you are using a gas heater, you will need to consider wind and drafts as well as heater exhaust for proper heater placement. (See heater

owner's manual for important location and safety information.)

- The equipment base and heater must be placed on either a 3 1/2" cement slab or 3" paving stones.
- Make sure the equipment area selected will not be in an area where water could run or stand.
- If the area receives direct sunlight, you will want to provide some protection for the equipment portion of the equipment pack.

The equipment pack and heater are delivered separately. Do not cover gas heaters unless properly vented. (See heater owner's manual for important safety information.)

Inground Spa Site Preparation

- Ensure there is enough room for the spa and equipment.
- Plan for proper electrical and gas service to both the equipment area and spa side.
- Ensure the required flat, level foundation can be constructed in the area chosen.
- The spa must be properly back-filled with wet sand, underneath and on all four sides.
- Never place any spa in a sealed area. Water must be able either to be absorbed into the surrounding area or channeled away. Water build-up under and/or around the spa, will cause the spa to float out of the ground.

4" thick as large as the bottom contact points. Be sure not to seal the bottom off and making a sealed box. You will need adequate water drainage for escape under the spa. A gravel beds around the concrete base will help with this.

Site Excavation – Sand Bottom

With the spa area and all elevations planned including your decided type of decking, you are now ready to proceed with the dig. An ideal excavation is one that is as close as possible to the dimensions of the spa shell, but with the following rules in mind. The excavation should be 2" to 4" deeper than the actual spa for your sand bed. The sand bed is to level the spa shell and provide a perfect support base with no voids when the spa is lowered into the hole. Your excavation should be approximately one foot longer and one foot wider than the spa shell. This will allow for a six inch over dig all the way around the spa once it is in place. Additional hand excavation will be required to insure the skimmer will fit in the excavation when attached to the spa.

Sand or rock dust must be used to bed the shell into the excavation and for backfill. In no event is dirt to be used. One of the easiest ways to know how much sand is needed to be placed on the bottom of the excavation is to set a grade stake at all four corners, and one on each side of the center line in the bottom of the hole. If there are areas that are deeper than 2" to 4", these can be filled with sand and are of no consequence.

Grading Prior to Excavation

Selection of the Designer Spas site will determine how much grading will have to be accomplished prior to the actual dig for the spa. Naturally, a level area is best because it will require the least amount of preparation for the dig, but in many cases there is no level area, therefore, the site must be prepared to accept the spa prior to dig. The spa site should be elevated slightly higher than the surrounding area.

When dealing with slopes, the severity of the slope will determine if retaining walls must be built in order to have a level area for the spa. If the slope is relatively minor, contact your local building safety.

Site Excavation – Hard Bottom

For hard bottom placement for inground spas, you will need a smooth and flat concrete surface at least

Spa Shell Dimensions and Side Views

IG-401

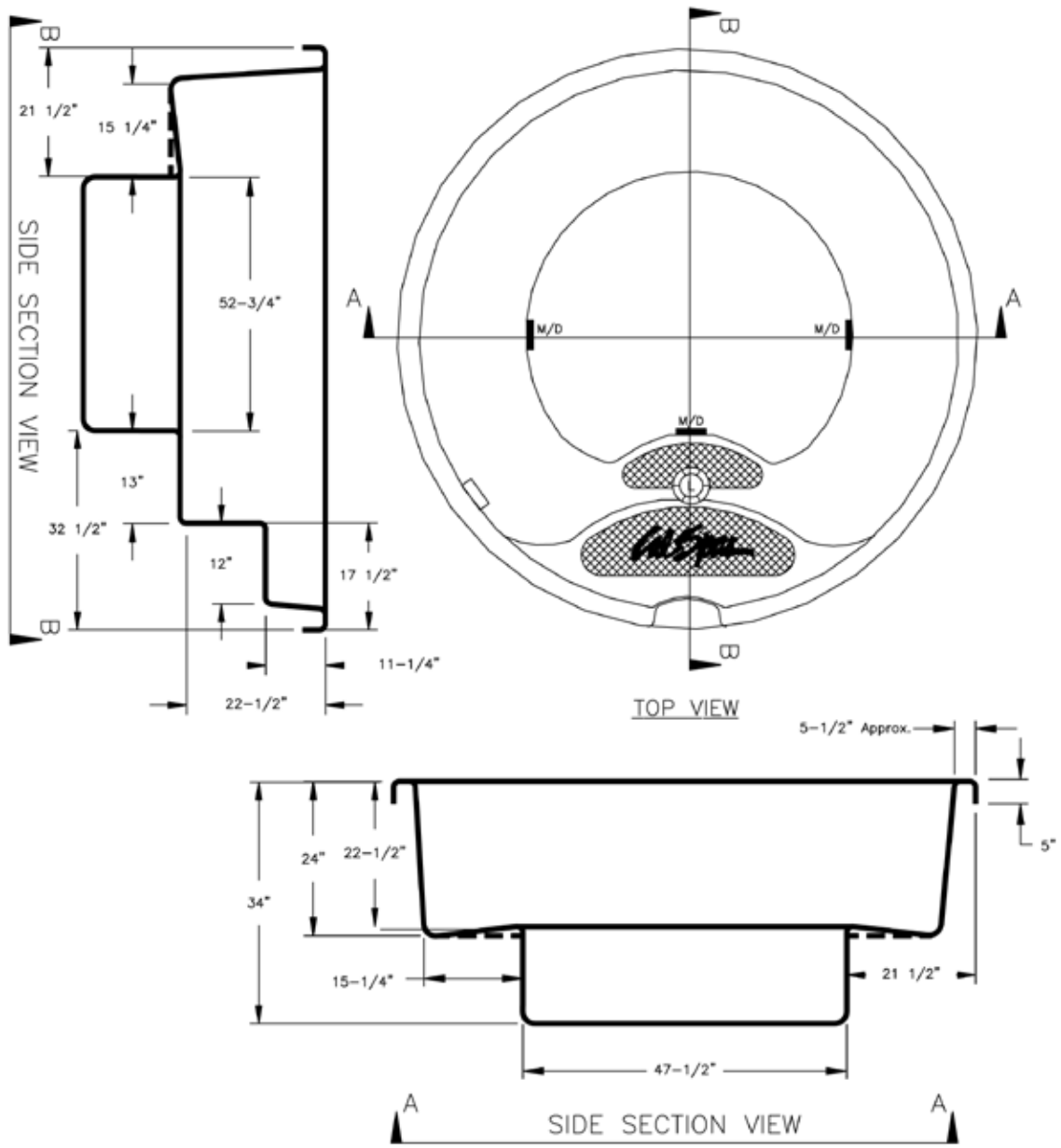

IG-402

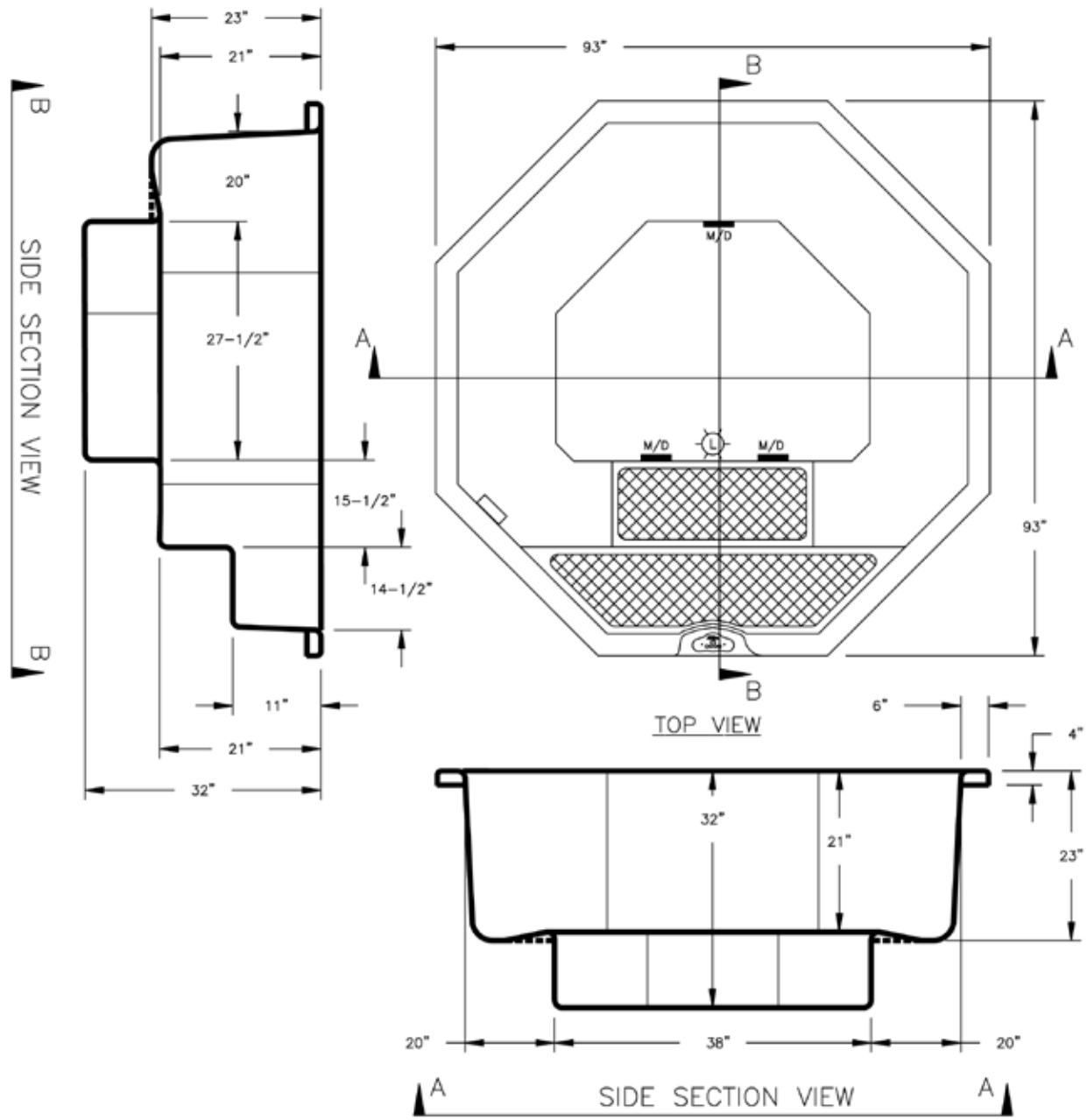

IG-403

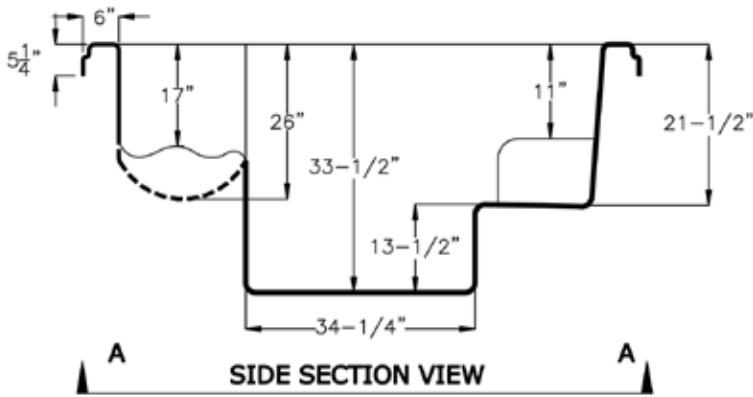
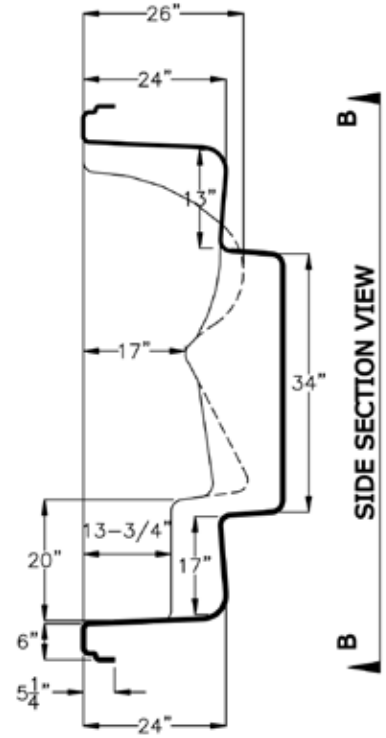
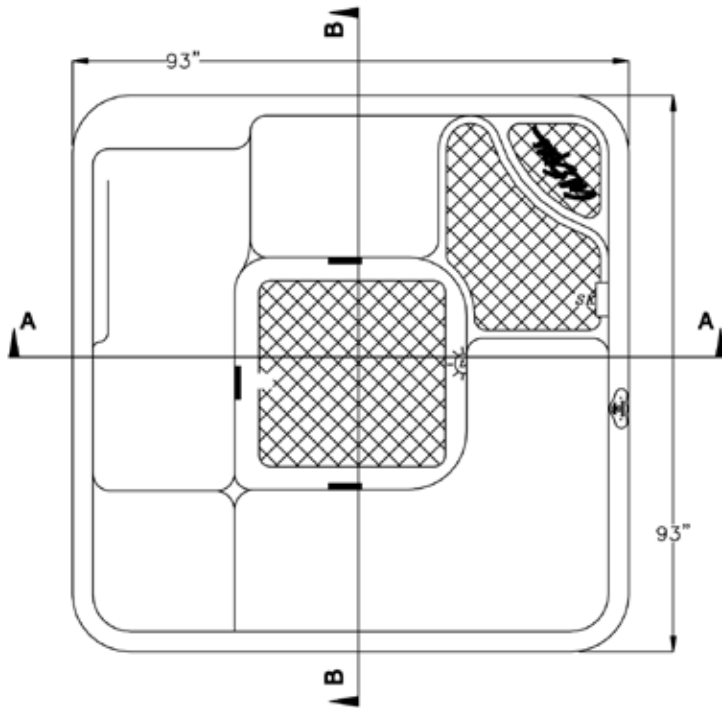

IG-404

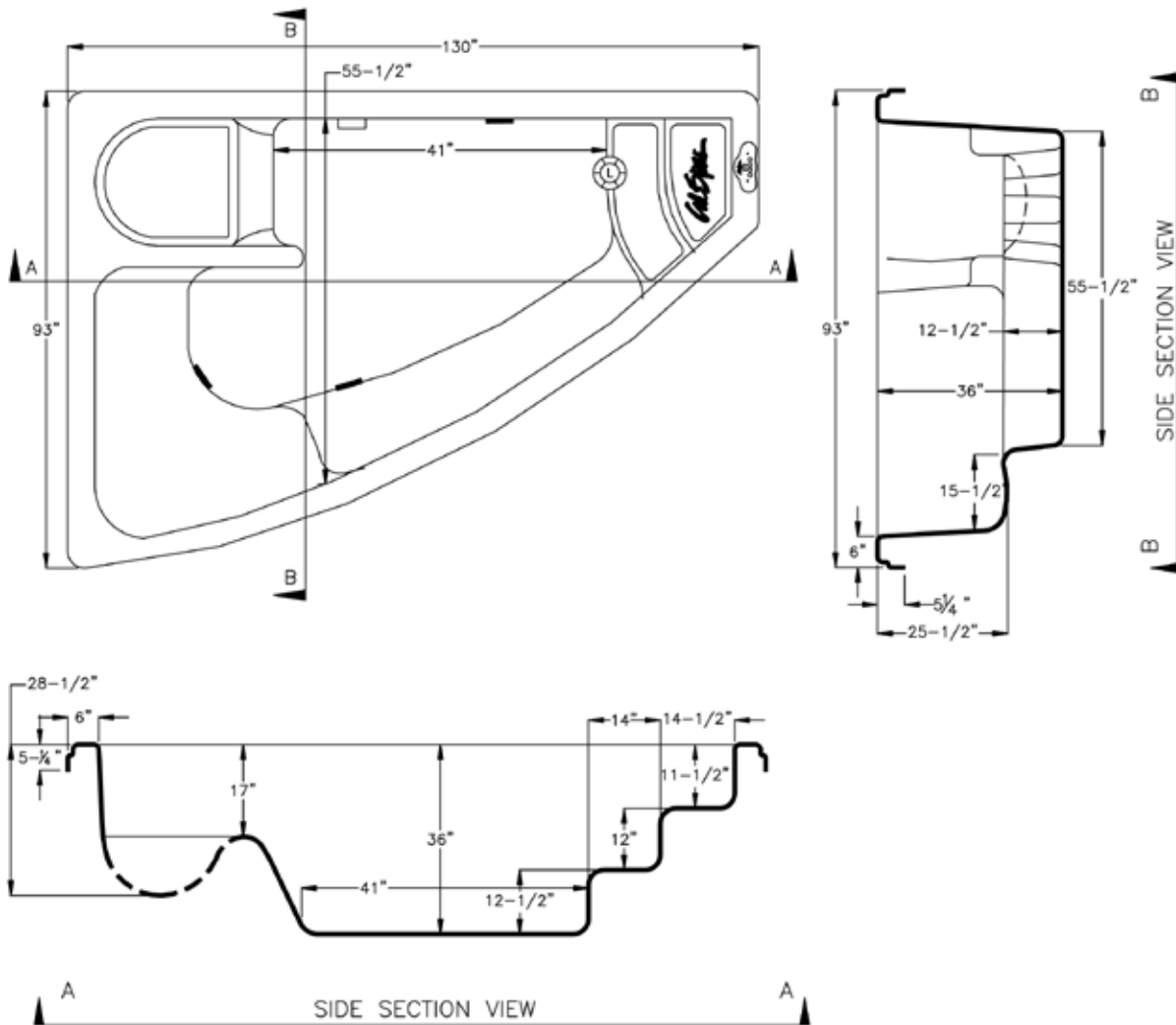

Preparing for Your New Inground Spa

IG-405

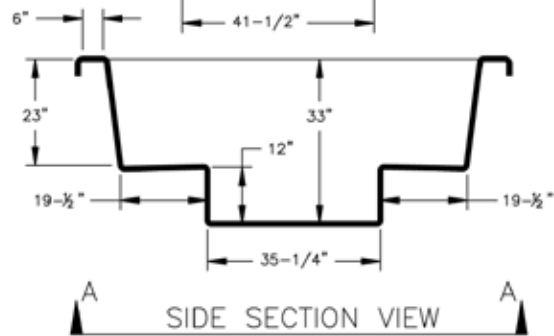
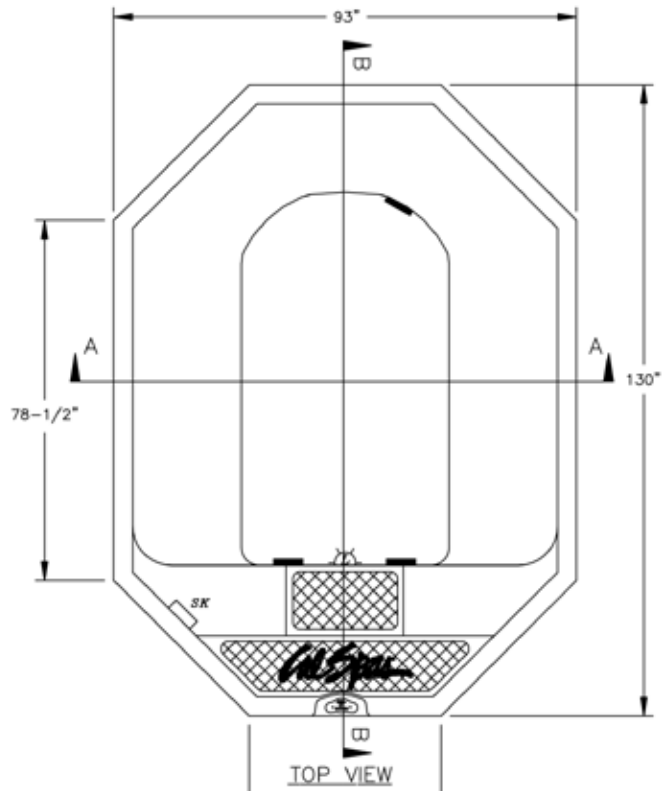
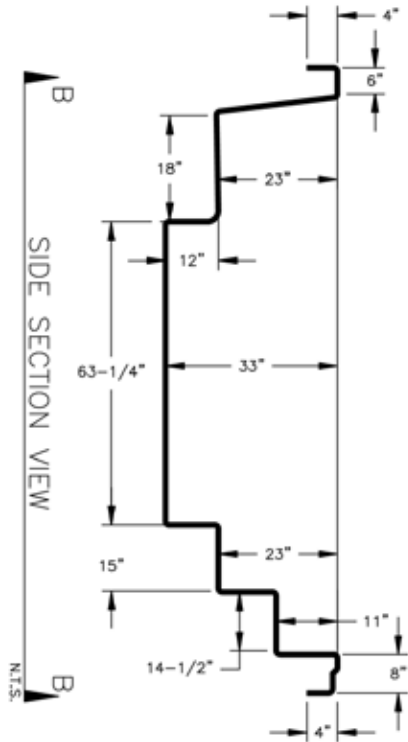

IG-406

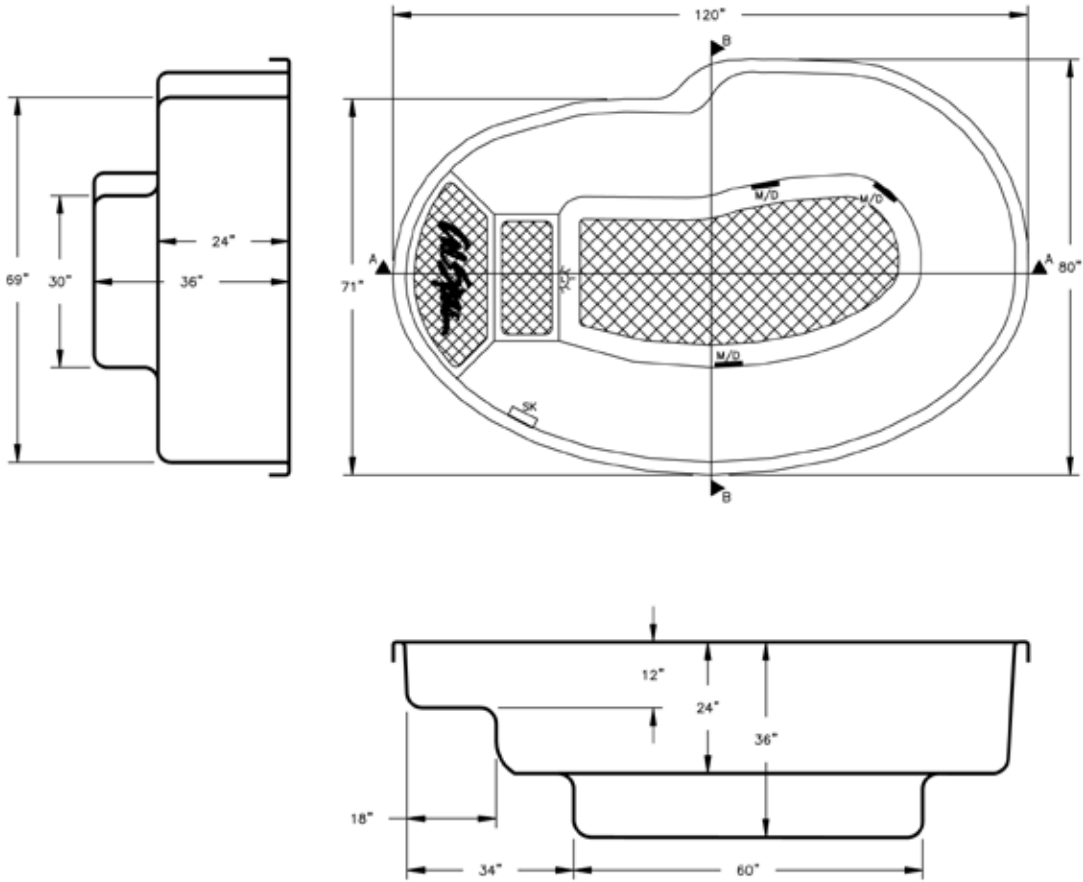

Preparing for Your New Inground Spa

IG-407

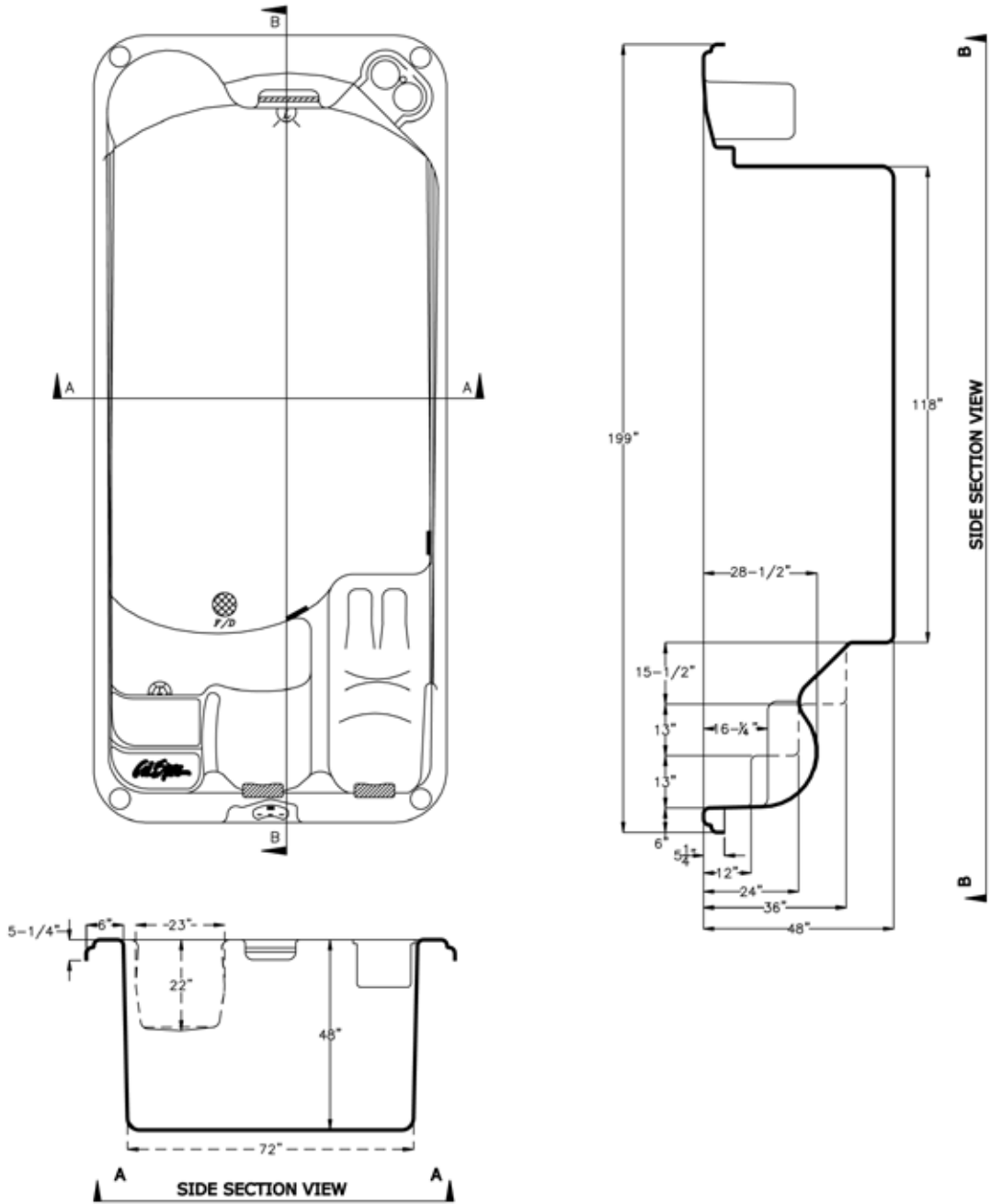

Electrical Requirements – US and Canada

All 240V spas must be permanently connected (hard wired) to the power supply. These instructions describe the only acceptable electrical wiring procedure. Spas wired in any other way will void your warranty and may result in serious injury. See the wiring diagram on page 14.

When installed in the United States, the electrical wiring of this spa must meet the requirements of National Electric Code, ANSI/NFPA 70-2008 and any applicable local, state, and federal codes. The electrical circuit must be installed by an electrical contractor and approved by a local building / electrical inspector.

GFCI and Wiring Requirements

The power supplied to the spa must be on a dedicated GFCI protected circuit as required by ANSI/NFPA 70 with no other appliances or lights sharing the power.

Use copper wire with THHN insulation. Do not use aluminum wire.

Use the table below to determine your GFCI and wiring requirements.

Wire runs over 85 feet must increase wire gauge to the next lower number. For example: A normal 50 amp GFCI with four #8 AWG Copper wires run over 85 feet would require you to go to four #6 AWG copper wires.

Read and follow the heater manufacturer’s safety and installation instructions prior to installation and operation. Incorrect installation may damage the heater and void its warranty.

Testing the GFCI Breaker

Test the GFCI breaker prior to first use and periodically when the spa is powered. To test the GFCI breaker follow these instructions (spa should be operating):

1. Press the TEST button on the GFCI. The GFCI will trip and the spa will shut off.
2. Reset the GFCI breaker by switching the breaker to the full OFF position, wait a moment, then turn the breaker back on. The spa should have power again.

Spa Model	GFCI Required	Wires Required
Designer inground spas with one 5.5 kW heater	One 50 amp GFCI	Four #6 AWG copper wires
Designer inground spa with two 5.5 kW heaters	Service 1: One 50 amp GFCI Service 2: One 30 amp GFCI	Service 1: Four #6 AWG copper wires Service 2: Three #8 AWG copper wires



GFCI Wiring Diagram

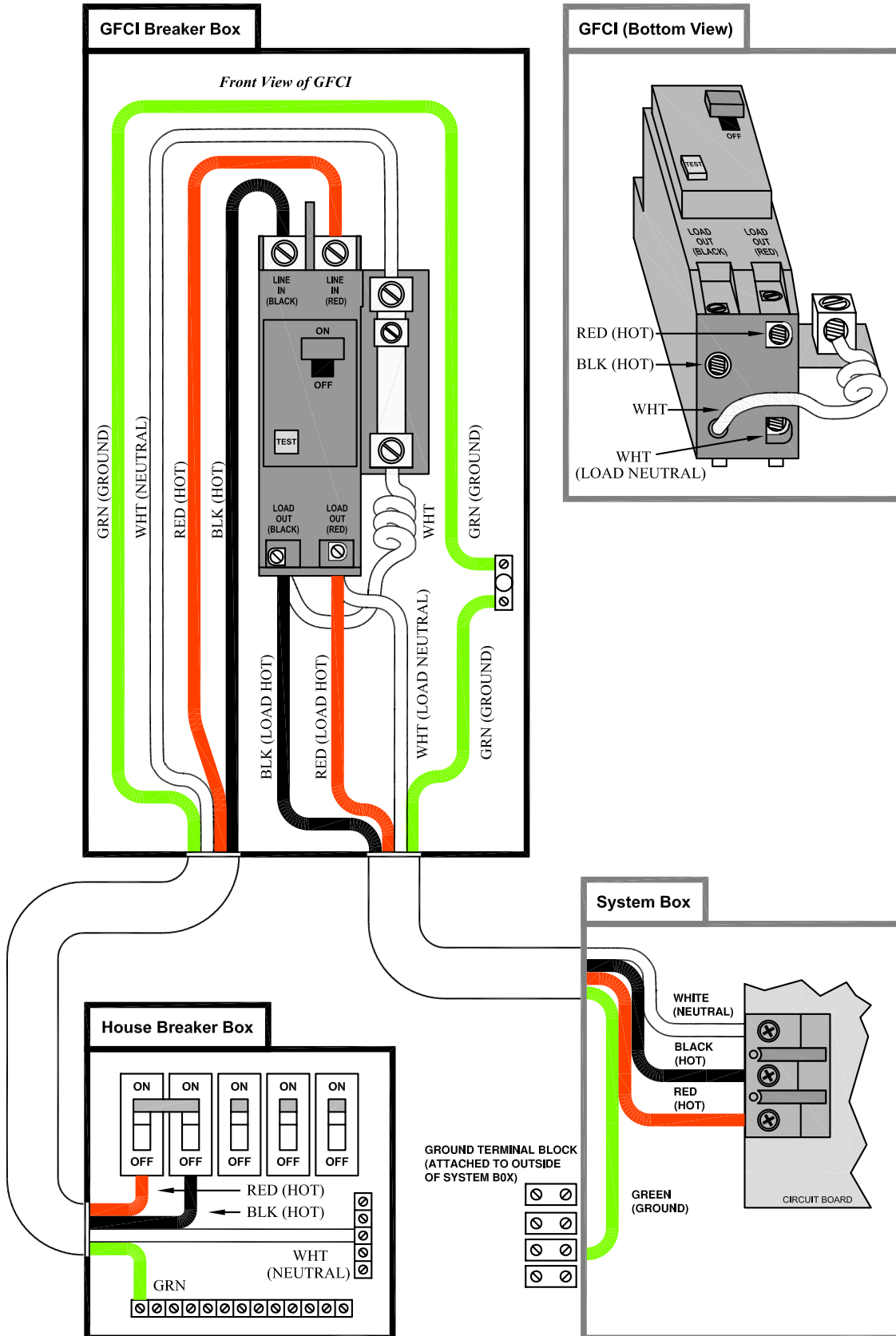

Electrical Installation -- Europe

All 230V spas must be permanently connected (hard wired) to the power supply. These instructions describe the only acceptable electrical wiring procedure. Spas wired in any other way will void your warranty and may result in serious injury.

This the only acceptable electrical wiring procedure. Spas wired in any other way will void your warranty. See the wiring diagram on page 16.

The electrical wiring of this spa must meet the requirements of any applicable local, state, and federal codes. The electrical circuit must be installed by an electrical contractor and approved by a local building / electrical inspector.

RCD and Wiring Requirements

The power supplied to the spa must be on a dedicated RCD protected circuit with no other appliances or lights sharing the power.

Use copper wire with THHN insulation. Do not use aluminum wire.

Use the table below to determine your GFCI and wiring requirements.

Wire runs over 85 feet must increase wire gauge to the next lower number. For example: A normal 50 amp RCD with four #8 AWG copper wires run over 85 feet would require you to go to four #6 AWG copper wires.

Testing the RCD Breaker

Test the RCD breaker prior to first use and periodically when the spa is powered. To test the RCD breaker follow these instructions (spa should be operating):

1. Press the TEST button on the RCD. The RCD will trip and the spa will shut off.
2. Reset the RCD breaker by switching the breaker to the full OFF position, wait a moment, then turn the breaker back on. The spa should have power again.

Spa Model	GFCI Required	Wires Required
Designer inground spas with one 3 kW heater	One 32 amp RCD or two 16 amp RCDs	Four #10 AWG copper wires
Designer inground spa with one 3 kW heater and one 5.5 kW heater	Service 1: One 32 amp RCD or two 16 amp RCDs Service 2: One 32 amp RCD or two 16 amp RCDs	Service 1: Four #10 AWG copper wires Service 2: Three #10 AWG copper wires



RCD Wiring Diagram

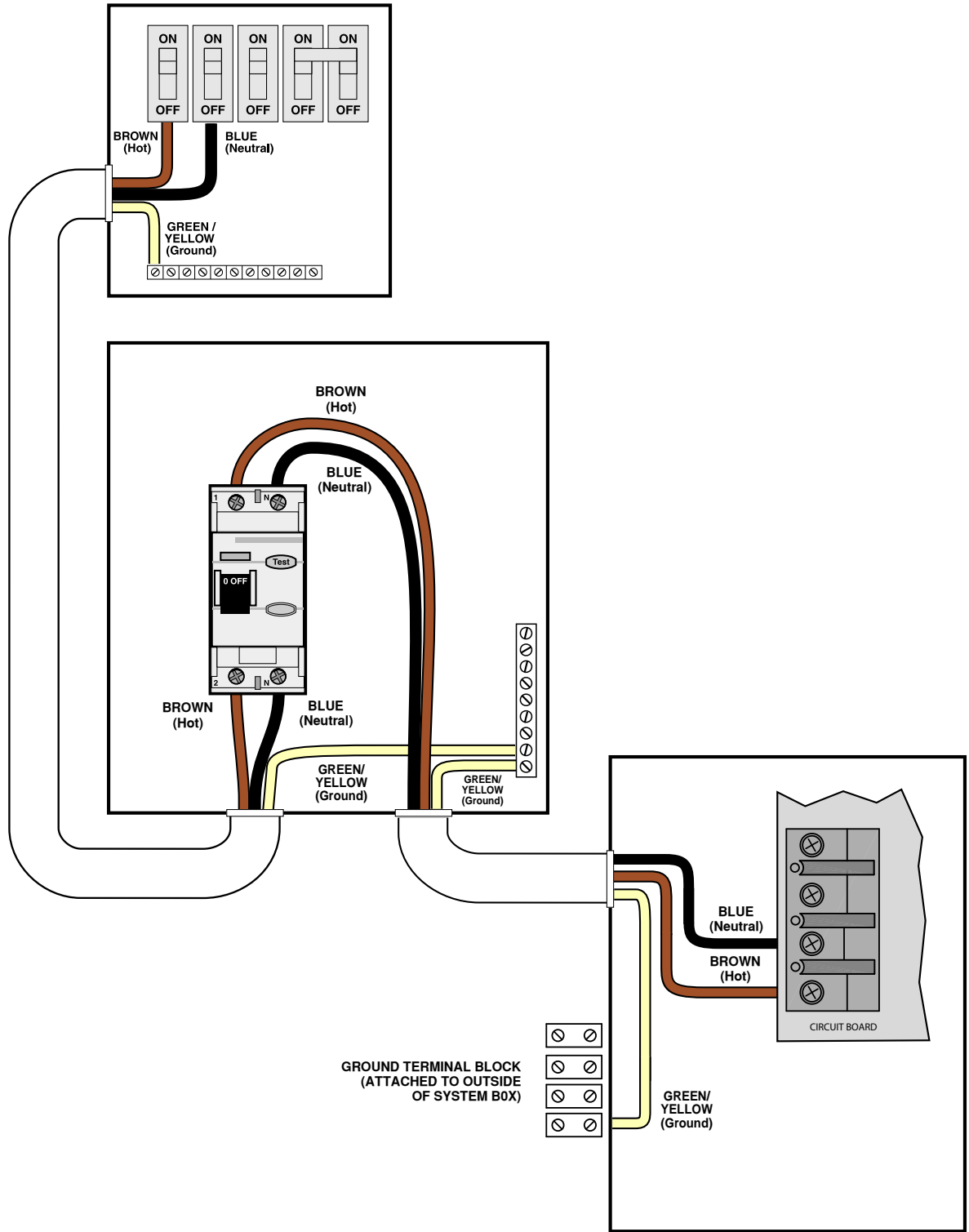

Installing the Inground Shell

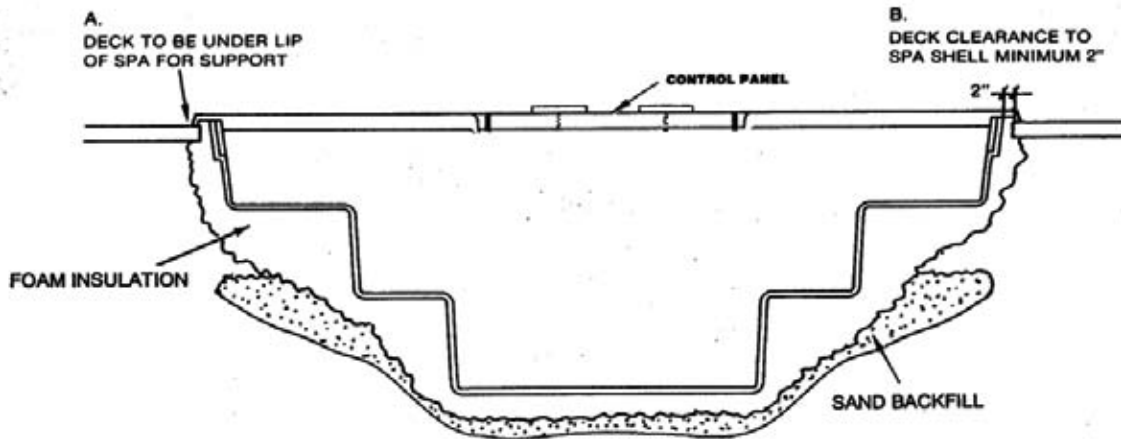

- A.** Deck must go under lip of spa uniformly for proper lip support. Lip is not to bear any weight from spa. Deck is only to stop lip from flexing when stepped or sat on.
- B.** Deck must not be poured up against spa, since cement expands and contracts as temperature changes. Leave a gap of 2" from shell for proper structure protection.

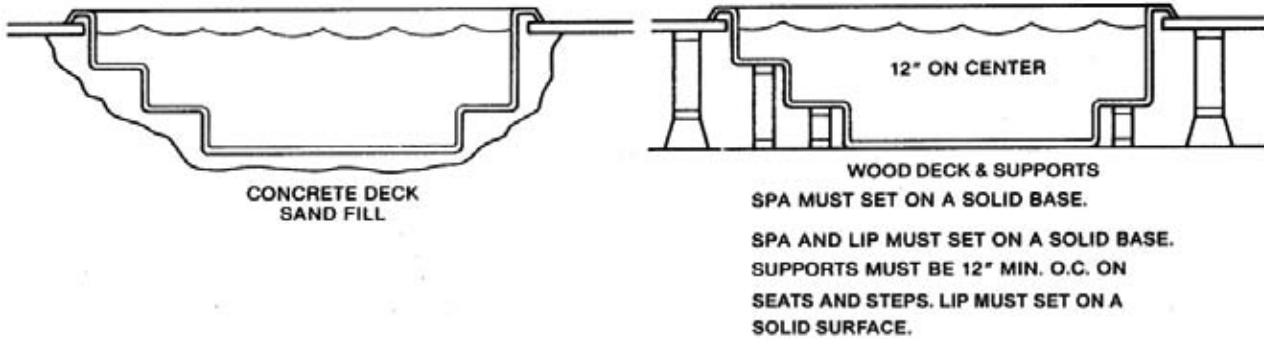

Equipment Pack Plumbing Connections

Equipment Pack Specifications

All Inground spas except IGJ-407:

Equipment pack weight = 250 lbs.

IGJ-407:

Equipment pack weight = 300 lbs.

One 2.5 HP heat pump

One 4 HP swim pump

Note: Equipment pack cannot exceed 15 feet from spa.

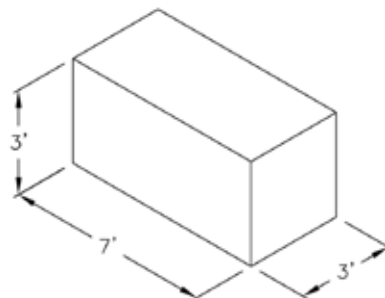

EQUIPMENT PACK DIMENSIONS

Plumbing Connections

IMPORTANT! Always check local codes prior to any inground spa installation.

Once the spa and equipment are properly located, you will want to lay out the plumbing run.

Trenches should be deep and wide enough to allow all pipes to be buried below the frost line and should be in as straight a line from the spa to the equipment as possible. Check local code requirements for underground pipes. Always know what is under the ground before you dig anywhere.

You will need 2" flex or PVC lines for your suction, intake, and air line. In ground spas have marked intake and suction lines, making it easy find and connect to and from the spa and equipment pack.

The plumbing run should not be any longer than 15 feet to maximize water pressure. Another way to maximize water pressure is to limit (or even eliminate) the use of 90° elbows in your plumbing run. A more direct plumbing run using 45° elbows is more efficient, and promotes increased water pressure.

Identifying Plumbing Lines

The spa's plumbing lines are clearly marked during water testing at the factory. This is done to assist installers in properly identifying the installation. We still recommend that the installers verify plumbing lines prior to gluing. This can be done by using one of the following techniques.

Air Test

The air test requires a wet/dry vacuum. Locate the plumbing line you wish to identify and secure the vacuum hose to cut open end. Turn on the vacuum, enter the spa and listen for vacuum suction sound from inside the spa side filter canister. If you hear the suction sound in the canister, the line is properly marked and can be connected to the suction side of the pump on the equipment pack.

Water Test

The water test requires a garden hose and water source. Locate the plumbing line you wish to identify and secure the outlet side of the garden hose to cut open end. Turn on the water supply to the garden hose, enter the spa and look for water inside the spa side filter canister. If you see water in the canister the line is properly marked and can be connected to the suction side of the pump on the equipment pack.

If any plumbing line is not properly marked or not marked at all, follow either the air or water test procedure until all lines are identified prior to gluing.

NOTE: Once complete, water test the plumbing run for at least three days prior to covering any plumbing trenches and back-filling spa cavity completely.

NOTE: Some local inspectors require pressure testing the plumbing lines. Although the spa is pressure tested at the factory, local inspectors may insist on pressure testing the plumbing run between the spa and equipment pack.

Gate/Slice Valves

The use of gate valves is recommended on all plumbing lines (both suction and return lines). These valves are used to contain the spa's water in either the equipment or the spa. This will assist in the pump priming process and future servicing without needing to drain the spa.

NOTE: When draining the spa to perform maintenance, always close the gate valves prior to draining. This will maintain the pumps prime.

Connecting Plumbing to Remote Equipment

Connecting the plumbing from the spa to the equipment pack must be performed in accordance to local and city codes.

NOTE: Most codes require plumbing to be rigid PVC schedule 40 or heavier in both above and below ground installations. In most cases, the use of flexible PVC plumbing is acceptable when properly buried in trenches.

Most water plumbing lines are 2" or larger and must be schedule 40 or heavier PVC. When plumbing, minimize the use of 90° elbows as much as possible. The use of 45° elbows will increase the amount of jet pressure you will have over the use of 90° elbows.

The plumbing on the spa shell is labeled by the factory in the following manner:

Pump 1 Suction: 2" line that connects the spa filter and bottom drain assembly to the front of pump 1.

Pump 1 Return: 2" line that connects the top of pump 1, through the equipment filter and heater back to selected jets in the spa.

Pump 2 Suction: 2" line that connects the spa filter and bottom drain assembly to the front of pump 2.

Pump 2 Return: 2" line that connects the top of pump 2 back to selected jets in the spa.

Ozone Line: 1" line that connects to a 1" flexible line extending off the bottom of the equipment pack filter canister through an ozone injector (If ozone equipped) and connected to ozone port on the spa.

Air Blower: 1 1/2" line that is plumbed out of the air blower (located on the equipment pack) and extended up 18" above the spas water level to prevent water flooding the air blower.

Air Venturi: 1/2" line that is plumbed 18" above the spa's water level.

Topside Control Panel and Temp Sensor: 1" line that connects to the bottom of the control box located on the equipment pack.

Electrical and Electronic Connection

Remote Equipment Topside Control Panel

The next few steps to complete the installation should be performed along with installation of the temperature sensor and 12V spa light wiring (if applicable). All of these components are generally installed using the same conduit.

1. Locate the topside control panel extension loom in the control box mounted with the equipment pack. This extension loom and attached black terminal connector (see figure at right) will be used to connect the topside control panel to the control box.
2. Connect one end of the black terminal connector to the topside control panel cable.
3. Connect the other end of the terminal connector to the extension loom.

NOTE: This connection must be kept dry. We recommend that a waterproof junction box be used in installations where moisture could penetrate this terminal connector.

4. Lay out the extension loom to verify that you have enough length to reach the control box. Remember that conduit runs are not generally run in a straight line. Every bend, and up and down run consumes line length. Take this into consideration when verifying electrical and plumbing runs.

5. Connect the extension loom to the control panel location on the circuit board located inside the control box. You will also need to connect both the temperature and high limit sensors to the circuit board prior to testing. (See the temperature and high limit installation instruction on the next page for proper identification and see the wiring diagram on the inside cover of the control box for proper placement.)
6. Turn on the power supply to the spa equipment and briefly test all functions on the topside control panel to verify that both connections and extension loom are in working order before proceeding with the installation.

NOTE: Circuit board programming will not allow spa operation without both the temperature and high limit sensors being properly connected to the circuit board.

7. Once topside panel operation is verified. Turn off power, disconnect the extension loom from the circuit board and GENTLY route through conduit to complete installation.

NOTE: This loom and its connector are not meant to withstand heavy pulling. Make sure, when routing the extension loom and temperature sensor lines through conduit, you exercise extreme caution.

Once properly run through the conduit, repeat steps 5 and 6 above.

Inground Spa Light Installation Instructions

On spas ordered with inground lights, the factory installs the light niche for you. The next steps of installation should be performed by a qualified licensed electrician.

Always read and follow light manufacturer's safety and installation instructions prior to installation and operation. Incorrect installation may damage the light and void its warranty.

The light circuit must be on a GFCI protected service (alone or with a switch).

The water resistant junction box (or for 12 volt models, the low voltage transformer) must be located:

- at least 8" (20 cm) above water level
- at least 4" (10 cm) above ground level, and
- at least 48" (121 cm) away from the spa.

See figure below.

Light niche and any metallic items in a 5' (152 cm) radius must be properly bonded with #8 AWG grounding wire.

1. Connect rigid conduit to the 3/4" hub located at the back of the light niche and run to a water resistant junction box (or for 12 volt models to a low voltage transformer) no further than 25' (7.6m). Remember this is a water cooled light, so the conduit and all connections must be leakproof.

2. Feed the light cord through the rigid conduit to the junction box, leaving at least 4 feet of cord at the end of the light fixture. This slack in the light cord will allow servicing without draining the spa in the future.
3. Wrap light cord slack around back of light housing and attach light to niche with mounting screw.
4. Cut the cord at the junction box, leaving at least 6" (15 cm) of cord to make connections.
5. Strip 6" (15 cm) of the out cord jacket to expose the three insulated wires. Be careful not to damage the insulation on the three inner wires.
6. Connect the three wires to the corresponding circuit wires in the junction box and secure the junction box cover in place.
7. Replace the light assembly in the niche and tighten the special pilot screw.
8. Fill the spa until the underwater light is completely submerged in water before operating the light for more than 10 seconds. Turn on the main switch or circuit breaker, as well as the spa light control, to check for proper operation

Important: Make sure spa light is submerged in at least 18" of water prior to testing.

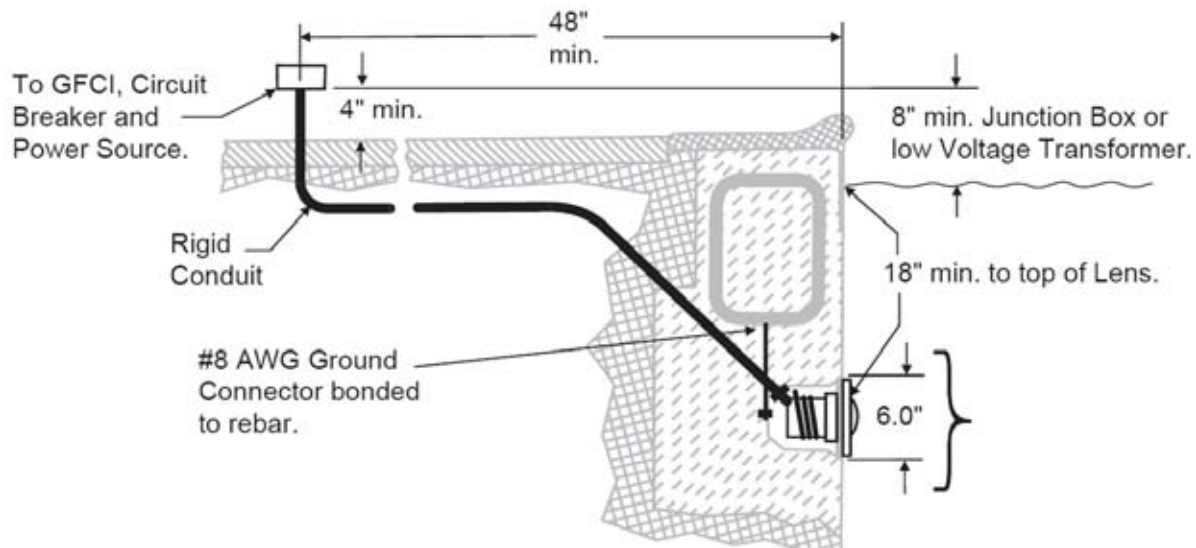

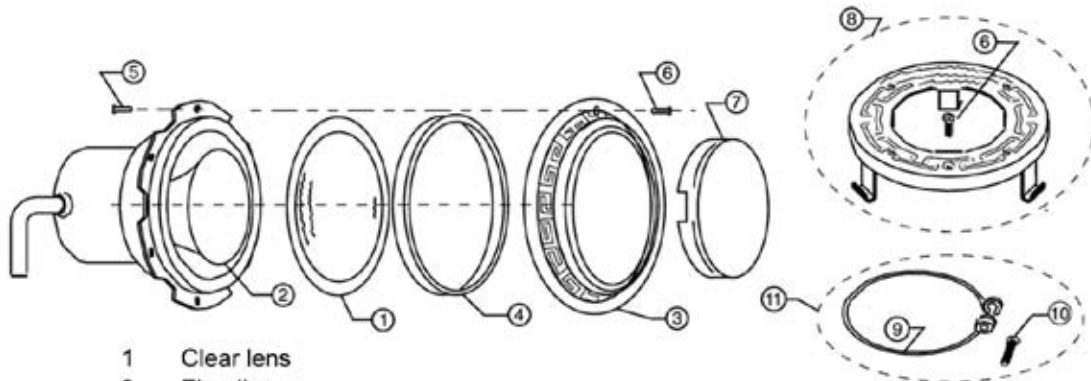
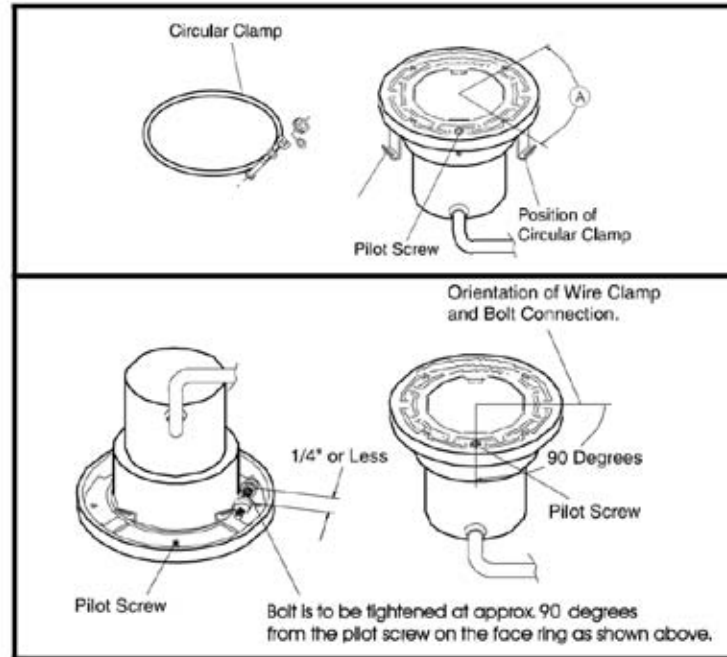

- 1 Clear lens
- 2 Floodlamp
- 3 Face ring, chrome-brass
- 4 Gasket, 4" diameter
- 5 Screw, stainless steel, 10-24 x 3/8" (6 required)
- 6 Pilot screw with captive gum washer
- 7 Kwik-change color lens
- 8 Face ring assembly
- 9 Wire spring clamp
- 10 1/4-20 x 5/8" bolt
- 11 Uni-tension wire assembly, stainless steel with welded nut

⚠ WARNING

Use only the special pilot screw provided with this underwater light. This screw mounts and electrically grounds the housing securely to the mounting ring and wet niche. Failure to use the screw provided could create an electrical hazard which could result in death or serious injury to pool users, installers or others due to electrical shock.

Pouring the Deck

It is recommended that all electrical hook ups and all plumbing be completed before pouring the concrete. Make certain all electrical inspections on lights, bonding and all other electrical work have been completed and checked off by the local inspectors prior to proceeding with your concrete or finish work. It is a good idea to run the spa for at least 24 hours before pouring the concrete to insure there are no leaks. We understand you want to enjoy your spa now, but a 24 hour period with your spa running will let you know of any problems before they will be extremely hard to fix.

The type of decking you have selected will have determined the grade of the spa. If you are pouring a regular deck up to the spas coping, then the top of the coping should be 4" above the surrounding area. In either event, it is recommended to dig out an area around the spa exposing the flange of the coping and

just under it. This is important, as concrete should be packed under and over the flange of the spa, as the deck is poured. This will lock the spa into the concrete and provide for a much stronger bond of the spa to the deck. It will also eliminate cracking of the deck where it meets the spa.

When setting your outside forms, remember you want any water from rain or splash out to run off the deck, not into the spa. If your deck is going to tie into an existing deck, then some type of drain system should be planned to handle the run off. Proper drainage planning is very important.

An experienced concrete finisher should always be used when pouring spa decks, especially when you are doing a cantilevered deck, as the forms must be taken off at the proper time to allow finishing of the inside of the form.

9800 Electronic Control Operation

Initial Start-up

When first powered up, your spa will perform a self-diagnostic check and then automatically go into priming mode. The topside will display PR to indicate this. Priming mode will be active for less than five minutes. When the spa has finished priming, the heater will be activated and the water temperature will be maintained in standard mode. The spa will automatically heat to 100°F (37.5°C) at start-up until you change the set temperature as listed in the "Temperature Adjustment" section below.

These instructions will describe features and options that your particular spa may not be equipped with.

Temperature Adjustment

80°F - 104°F (26.0°C - 40.0°C)

The start-up temperature is set at 100°F (37.5°C). The last measured temperature is constantly displayed on the control panel. Note that the last measured spa temperature is displayed.

The displayed temperature will be updated when the pump has been running for at least two minutes.

Press the "UP" or "DOWN" buttons once to display the set temperature. Each time either button is pressed again, the set temperature will increase or decrease depending on which button is pressed. After three seconds, the control panel will automatically display the last measured spa temperature.

Time

When time hasn't been programmed, the "TIME" icon flashes. To set the time, press the "TIME" button and then the "MODE/PROG" button. Use the "UP" and "DOWN" buttons to adjust time. See the next page for more detailed instructions.

Standard, Economy, Sleep, and Standby Modes

Mode/Prog: This button is used to switch between standard, economy, and sleep modes.

1. Press "MODE/PROG" to enter mode programming.
2. Press the "DOWN" button to cycle through to the desired mode.
3. Press "MODE/PROG" to confirm selection.

Standard Mode: This is programmed to maintain the desired temperature. Note that the last measured spa temperature displayed is current only when the pump has been running for at least two minutes. The "STAND" icon will display until the mode is changed.

Economy Mode: Economy mode heats the spa to the set temperature only during filter cycles. The "ECON"



icon will display until the mode is changed. Pressing the "JETS 1" button while in economy mode puts the spa in standard-in-economy mode, which operates the same as standard mode but reverts back to economy mode automatically after one hour. During this time, pressing the "MODE/PROG" button will revert to economy mode immediately.

Sleep Mode: Sleep mode heats the spa to within 20°F (6.7°C) of the set temperature only during filter cycles. The "SLEEP" icon will display until the mode is changed.

Standby Mode: Pressing "Warm" or "Cool" then "JETS 2" will turn off all spa functions temporarily. This is helpful when changing a filter. Pressing any button resets the spa.

Jets 1 and Jets 2

Press the "JETS 1" button once to turn pump 1 on or off and to shift between low and high speeds if equipped. If left running, the low speed turns off after two hours and the high speed turns off after 15 minutes. On non-circulation systems, the low speed of pump 1 runs when the blower or any other pump is on. It may also activate for at least two minutes every 30 minutes to detect the spa temperature and then to heat to the set temperature if needed, depending upon the mode. When the low speed turns on automatically, it cannot be deactivated from the panel; however, the high speed may be started.

Option

This is an optional feature. Press the "OPTION" button to turn the optional equipment on and off. If left

on, the equipment will automatically turn off after 15 minutes.

Light

Press the "LIGHT" button to turn the spa light on and off and to shift between dim and bright settings if your light is dimmable. On dim, the control panel will show the center circle plus one quarter of the light beams. Half of the light beams will show on medium brightness, and all of the light beams will show on bright.

Invert

Press the "INVERT" button to change the numbers in the display to read upside down. Another press returns the display to the right-side-up position. This enables you to read the display while you are in the spa.

Locking the Panel

To lock the panel:

- Press "TIME", "JETS 1", and the "UP" button within three seconds. When locked, the panel will display "LOCK". All buttons are frozen except the "TIME" button.

To unlock the panel:

- Press "TIME", "JETS 1" then the "DOWN" button within three seconds.

Setting the Temperature Lock

To activate the temperature lock:

- Press the "UP" or "DOWN" button, "TIME", "JETS 1", then the "UP" button within three seconds. The panel will display "TEMP LOCK" when the set temperature is locked.

To unlock the set temperature:

- Press the "UP" or "DOWN" button, "TIME", "JETS 1", and then the "DOWN" button.

Circulation Pump

This is an optional feature. The circulation pump will come on when the system is checking temperature, during filter cycles, during freeze conditions, or when another pump is on.

Preset Filter Cycles

There are two filter cycles per day. The start and end times of each cycle are programmable. To program, set the time as instructed above, then press "MODE/PROG" to advance to the next setting (or to exit after the last setting). The default filter cycles are as follows:

- The first filter cycle is automatically activated at 8:00 AM and operates the pump until 10:00 AM. The "FILTER 1" indicator icon will light when filter 1 is running.
- The second filter cycle is automatically activated at 8:00 PM and operates the pump until 10:00 PM. The "FILTER 2" indicator icon will light when filter 2 is running.

The pump and the ozone generator will run during filtration. At the start of each filter cycle, the blower will run on highest speed for 30 seconds to clean out the air channels. The lowest speed of pump 2 and pump 3 will run for five minutes. In the event of power loss or shut down, the time of day will need to be reset for filter cycles to run according to your desired programming.

Clean-up Cycle

When the pump or blower is turned on by a button press, a clean-up cycle begins 30 minutes after the pump or blower is turned off or times out. The pump and the ozone generator will run for one hour.

Ozone

This is an optional feature. On most systems, the ozone generator (if installed) runs during filter cycles (except when pump 1 is operating at high speed on a non-circ system) and during clean-up cycles. On some systems, the ozone generator operates whenever the pump runs. If your system is configured with the optional ozone disable feature, the ozone generator will turn off for one hour any time a function button ("JETS 1", "JETS 2", "OPTION" etc.) is pressed.

Freeze Protection

If the temperature sensors detect a drop to 44°F within the heater, the pump automatically activates to provide freeze protection. The equipment stays on until four minutes after the sensors detect that the spa temperature has risen to 45°F or higher. In colder climates, an optional additional freeze sensor may be added to protect against freeze conditions that may not be sensed by the standard sensors. Auxiliary freeze sensor protection acts similarly except with the temperature thresholds determined by the switch and without a four-minute delay in turnoff.

Periodic Reminder Messages

Press the "Mode" button to reset a displayed reminder.

Message	Frequency	Action Required
rPH	Every 7 days	Test and adjust chemical levels per manufacturer's instructions.
rSA	Every 7 days	Test and adjust chemical levels per manufacturer's instructions.
rCL	Every 30 days	Remove, clean, and reinstall filter per manufacturer's instructions.
rtg	Every 30 days	Test and reset GFCI per manufacturer's instructions. Drain and refill spa per manufacturer's instructions.
rdr	Every 90 days	Drain and refill spa per manufacturer's instructions.
rCO	Every 180 days	Clean and condition spa cover
rCH	Every 365 days	Install New Bio-Clean™ Filter

Your new Cal Spa comes equipped with an electric heater. Following the directions listed below will ensure the most efficient operation:

NOTE: This method is only for spa usage under two hours a week.

- Keep the spa's operating temperature 5° F below the desired usage temperature when not in use. One or two hours before use, set the temperature to the desired temperature.
- If the spa usage exceeds two hours a week, the set temperature should remain at the desired usage temperature.
- The air venturis should be used sparingly. When open, water temperature drops quite rapidly and can also dissipate chemicals.

Allowing the water temperature to lower more than 10°F below the desired usage temperature and reheating it prior to usage will cause the heater to operate longer than it normally would maintaining the desired temperature. Doing this will increase your operating cost and makes your heater work more than necessary.

Diagnostic Messages

Message	Meaning	Action Required
No message on display	<p>1) Spa temperature is unknown.</p> <p>2) Spa is in Economy or Sleep mode.</p> <p>3) Power has been cut off to the spa.</p>	<p>1) After pump has been running for 2 minutes temperature will be displayed.</p> <p>2) In Economy or Sleep mode, the pump may be off for hours outside a filter cycle. If you wish to see the current spa temperature, either switch to Standard mode or turn Jets1 on for at least two minutes.</p> <p>3) The control panel will be disabled until power returns. Spa settings and time of day will be preserved for 30 days with a battery back-up.</p>
BUF	Internal problem detected.	Repair required. Contact your dealer or service organization.
dr	Insufficient water detected in heater. Spa will be shut down for 15 minutes.	Check water level in spa. Refill if necessary. Make sure pumps are primed and filter cartridges are clean. Press any button to reset or wait 15 minutes and spa will automatically reset. If message spa does not reset, call your dealer or service organization.
dry dY	<p>Insufficient water detected in heater. Spa is shut down.</p> <p>(Displays on third occurrence of dr message.)</p>	Follow directions for dr message and press any button to reset spa. Spa will not automatically reset when dry or dY is displayed.
Ec	Indicates heater is in Economy Mode.	None.
--F or --C	Temperature unknown	After the pump has been running for two minutes, the temperature will be displayed.
HL HFL	A difference in readings between temperature sensors has been detected indicating a possible water flow problem.	Make sure spa is filled to proper level and that pumps are primed and filter cartridges are clean. If message does not reset, call your dealer or service organization.
IC ICE	Potential freeze condition detected.	No action required. The pumps and the blower will automatically activate regardless of spa status.
LF	Persistent low flow problems. Heater is shut down, but other spa functions continue to run normally. Displays on the fifth occurrence of the HL or HFL message within 24 hours.	Follow action required for HL or HFL message. Heating capacity of the spa will not reset automatically. Press any button to reset.
OH OHS	Overheat protection. The spa has shut down. One of the sensors has detected that the spa water is 110°F.	DO NOT ENTER THE WATER. Remove the spa cover and allow water to cool. At 107°F, the spa should automatically reset. If spa does not reset, shut off the power to the spa and call your dealer or service organization.

Message	Meaning	Action Required
HH OHH	Overheat protection (spa is shut-down). One sensor has detected 118°F (48°C) at the heater.	DO NOT ENTER THE WATER! Remove the spa cover and allow spa to cool below 107°F (42°C). Press any button on the topside display to reset spa. If spa will not reset after spa has cooled, turn off power for approximately 30 seconds and then turn power back on. If display message is repeated then shut the power off to the spa and call your dealer or service organization.
Pr	When your spa is first actuated, it will go into priming mode.	The priming mode will last for up to four minutes and then the spa will begin to heat and maintain the water temperature in the Standard mode.
SF	Safety Suction. Spa is shut down.	The display will show SF when a vacuum switch closes. All functions will turn off and the system will be disabled until a panel button is pressed.
SL	Indicates heater is in Sleep Mode.	None.
SA Sb SNA Snb	Spa is shut down. The sensor that is plugged into the sensor "A" or "B" jack is not working.	If the problem persists, contact your dealer or service organization. (May appear temporarily in an overheat situation and disappear when the heater cools.)
Sns Sn	Sensors are out of balance. <ul style="list-style-type: none"> • If this is alternating with the temperature, it may just be a temporary condition. • If the display shows only this message (periodically blinking), the spa is shut down. 	Contact your dealer or service organization.
ST	Indicates heater is in Standard Mode.	None.
Stby	Pressing a button combination on the user panel has activated Standby Mode.	Press any button to leave Standby Mode and return to normal operation.

Adjustable Jets

Almost all of the jets in your spa are adjustable. Rotating the face of an adjustable jet to the left (counter-clockwise) will decrease the amount of water flow through the jet. Rotating the face of an adjustable jet to the right (clockwise) will increase the amount of water flow through the jet.

Neck jets adjust in the opposite directions (counter-clockwise to increase, clockwise to decrease).



Diverter Knobs

Diverter knobs are 1" and 2" knobs located around the top of your spa. They allow you to divert water through jets from one side of the spa to the other, or in most cases from floor jets to wall jets. This is accomplished by rotating the diverter knob to the left (counterclockwise), decreasing the amount of water flow through a section of jets. To increase the amount of water flow through the other section of jets, rotate the handle to the right (clockwise).



Clear Water Plan

This section is intended for new spa owners with no experience with water chemistry. Everyone's experience with maintaining water quality is different, but there are some general concepts you need to know.

Water maintenance is not difficult, although it requires regular attention. The most important thing to understand about taking care of your spa water is that preventive action is much easier than correcting water quality issues.

Contents of this section:

Testing and Adjusting Spa Water
Sanitation
Filtration
Bather Load
Starting the Spa with Fresh Water
Maintenance Schedule
Troubleshooting Water Clarity Problems

The Key to Clear Water

Excellent water quality is a simple matter of four things:

Regularity

Clear water requires regular maintenance. Establish a routine based on a regular schedule for your spa water maintenance.

Maintaining your water quality helps the enjoyment of your spa and extends your spa's life by preventing damage from neglect and chemical abuse.

See page 35 for the schedule of recommended maintenance.

Filtration

Cleaning your filter regularly is the easiest and most effective single thing you can do to keep your water clear.

A clogged or dirty filter will cause the heater and pump to work harder than they need to, possibly causing them to fail.

The spa's heating system will only function with the proper amount of water flow through the system.

See page 33 for filter cleaning instructions.

Sanitation

Sanitizers kill bacteria and viruses and keep the water clean. A low sanitizer level will allow microbes to grow quickly in the spa water.

We recommend using either chlorine or bromine as your sanitizer.

See page 32 for learn how to use sanitizer.

Chemical Balance

You will need to test and adjust the chemical balance of your spa water. Although this is not difficult, it needs to be done regularly.

Depending on your choice of sanitizer, you need to test the level of calcium hardness, total alkalinity, and pH.

See page 32 for learn how to balance your spa water.



Testing and Adjusting Spa Water

You have two types of testing methods to choose from:

- The **reagent test kit** is a method which provides a high level of accuracy. It is available in either liquid or tablet form.
- **Test strips** are a convenient testing method commonly used by spa owners.

Balancing the Total Alkalinity

Total alkalinity (TA) is the measure of the total levels of carbonates, bicarbonates, hydroxides, and other alkaline substances in the water. TA can be considered a "pH buffer". It is the measure of the ability of the water to resist changes in pH level.

The recommended total alkalinity is 80 - 120 ppm.

If the TA is too low, the pH level will fluctuate widely from high to low. Low TA can be corrected by adding a pH-alkalinity increaser.

If the TA is too high, the pH level will tend to be too high and may be difficult to bring down. High TA can be corrected by adding a pH-alkalinity decreaser.

When the TA is balanced, it normally remains stable, although adding water with high or low alkalinity will raise or lower the TA level.

Balancing the Calcium Hardness

Calcium hardness (CH) is a measure of the total amount of dissolved calcium in the water. Calcium helps control the corrosive nature of the spa's water and is why soft water is not recommended. The low calcium content of soft water is very corrosive to the equipment and can cause staining of the spa shell.

The recommended calcium hardness is 150 - 200 ppm.

If the CH is too low, add a calcium hardness increaser.

If the CH is too high, dilute the spa water with soft water.

When the CH is balanced, it normally remains stable, although adding soft water or very hard water will raise or lower the CH level.

Balancing the pH

The pH level is the measure of the balance between acidity and alkalinity.

If the pH is too low, it can cause corrosion of metal fixtures and the heating element. Low pH can be corrected by adding a pH-alkalinity increaser.

If the pH is too high, it can cause scaling by allowing metals or minerals to form deposits and stain spa surfaces. High pH can be corrected by adding a pH-alkalinity decreaser.

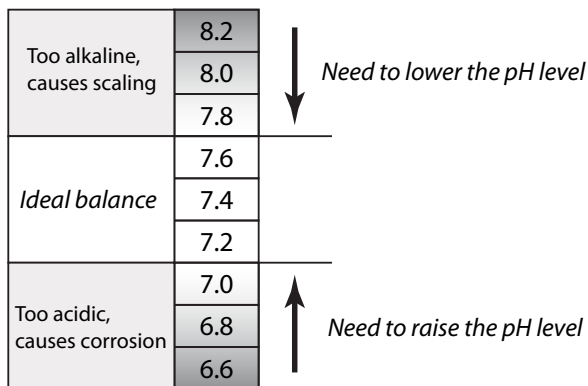

Testing For:	Ideal Range (ppm)	
	Minimum	Maximum
Total Alkalinity	80	120
Calcium Hardness	150	200
pH	7.4	7.6

Sanitation

After you fill your spa, you need to decide which chemical sanitizer you wish to use. Consult your Cal Spas dealer for the right decision with regards to your lifestyle and spa usage.

We recommend either **bromine** or **chlorine** as your sanitizer. Both work well when maintained regularly.



DO NOT use trichlor. Trichlor is very acidic and the hot temperature of the spa causes it to dissolve too quickly. It will cause damage to your spa and will void your warranty.

Sanitizers kill bacteria and other organic waste by breaking them down to non-harmful levels and are filtered out.

Make sure you follow all instructions.

Whichever plan you decide on, follow it completely and don't take shortcuts. It will provide you with clean, safe, clear spa water with a minimum of effort.

Using Chlorine as a Sanitizer

If you choose to use chlorine as a sanitizer, only use granulated chlorine, not liquid chlorine.

Once a week, check the chlorine level using either a test strip or a reagent kit. See the table on the following page for the ideal range.

Add one or two tablespoons of granulated chlorine to the spa water weekly. Note that chlorine dissipation rate will be faster at higher water temperatures and slower at lower temperatures.

When you add chlorine, open all of the jets and run the spa at high speed with the cover open for at least 30 minutes.

Follow the maintenance schedule on page 35.

Using Bromine as a Sanitizer

Bromine is a very effective sanitizer that produces low chemical odors. Unlike chlorine, it can break down bacteria and other impurities to a safe level with a low burn-out rate.

Bromine is available in both granulated and tablet form. Use granulated bromine to establish your bromine base. Use tablets to maintain it.

When you begin with fresh water, add 2 ounces of granulated bromide. Open all of the jets and run the spa at high speed. This is your base bromine level as the tablets will take a while to dissolve.

Place three or four bromine tablets in the chamber inside the floater.

Follow the maintenance schedule on page 35.

Testing For:	Ideal Range (ppm)	
	Minimum	Maximum
Chlorine level		
Without ozonator	3.0	5.0
With ozonator	2.0	4.0
Bromine level		
Without ozonator	6.7	11.0
With ozonator	5.7	10.0

Shocking the Water

In addition to using a chemical sanitizer, you will periodically need to shock the water. Shocking the water helps remove burned-out chemicals, bacteria, and other organic material from your spa's water and improves your sanitizer's effectiveness.

Do not use chlorinating shock, which will damage your spa's jets and pump seals. Only use an oxidizer shock. It can be used with either chlorine or bromine sanitizers.

Add one ounce of oxidizer shock once a week, after heavy bather loads, or if the water has a strong odor.

Spa must be running with all of the jets on high for 30 minutes with the cover open. If necessary, repeat oxidizer shock in 30 minute intervals.

Chemical Safety



Read and follow all printed instructions listed on bottles, packages. Failure to follow chemical directions may result in serious injury, sickness, or even death.

Do not exceed chemical dosages as recommended in the Clear Water Plan or on chemical bottles and packages.

Never change chemical brands or types without completely draining, flushing and thoroughly cleaning the spa and cover first.

Never mix chemicals together.

Do not allow chemicals to come in contact with skin, eyes or clothing. Remove and wash clothing that

may have been exposed to chemical contact prior to wearing them again.

Inhaling or ingesting chemicals will cause serious injury, sickness, or even death.

Chemicals must be stored completely out of the reach of children in an area that is well vented, cool, and dry. Failure to provide a proper area for chemical storage may result in serious injury, sickness, fire explosion and even death. Do not store your chemicals inside the equipment area of your spa.

Filter Cleaning

The filter is the part of your spa that removes the debris from the water and needs to be cleaned on a regular basis to maximize your spa's filtering performance and heating efficiency.

In addition to spraying off the filter weekly to remove surface debris, your filter should be deep cleaned periodically to dissolve scale and particles that get lodged deep within the filter fibers and impede the filtration process. Even if the filter looks clean, scale and particles can clog the fibers and prevent water from flowing through the filter resulting in the most common spa problem—no heat, caused by a dirty filter.

We recommend you clean your filter once a month and replace it once a year or as necessary.

1. Remove the filter by turning it counterclockwise, unscrewing the bottom threads, then pulling it up and out.

2. Place the dirty filter into a bucket of water deep enough to cover the filter. Add 8 oz of liquid filter cleaner to the bucket of water.

Note: It is a good idea to keep a spare filter to use in the spa while the dirty filter is being deep cleaned. This way, you can rotate the filters and both will last longer.

3. Twist off the tablet tube and set it aside
4. Soak the filter for a minimum of 24 hours.
5. Spray the filter with a water hose. Spray each pleat carefully.
6. Put fresh bromine in the tablet tube (if you use it as a sanitizer) and twist it back on top of the filter.
7. Reinstall the filter. Do not overtighten.

Bather Load

“Bather Load” is the term used to describe the number of people using a spa, combined with the length of usage, and the frequency of usage. All these factors have a great effect on the spa water. The higher the bather load, the more chemicals need to be added and a longer filtration time will be needed.

All versions of the Cal Spas Clear Water Plan are designed for spas with average bather load (3 to

4 people, 15 minutes of usage, three times a week at 100 degrees) If your bather load exceeds these guidelines, and you experience water quality problems, increase the amount of filtration first, (go to the next higher filtration number) then if water quality is still not adequate, consult the advice of your Cal Spas dealer for additional chemical or system recommendations. Be sure to give them your bather load information.

Starting the Spa with Fresh Water

Prior to filling a spa for the first time, or after a routine draining, you will want to follow this start-up plan to extend water life and performance.

As with all chemical dosages listed in these Clear Water Plans, start-up dosages are intended for 500-gallon spas. Please adjust the chemical dosages to the capacity of your particular spa.

1. Clean the surface of the spa with a multi-purpose cleaner.
2. Apply a protective coat of surface protectant to the acrylic surface.
3. Fill the spa to the proper water level with normal tap water. (Do not use soft water.)
4. Use test strip and balance the spa water.
5. Add either chlorine or bromine (but not both).
 - Adjust total alkalinity (acceptable range is 80-120ppm).
 - Adjust pH if necessary (between 7.2 to 7.8).
6. Turn on jets for 15 minutes. Leave spa uncovered during this time.
7. Put cover on spa and allow to heat up to desired temperature.

Chlorine: Add two tablespoons of granulated chlorine to the spa water.

Bromine: Add 2 oz of granulated bromine to establish a bromine base.

Add 2 bromine tablets to bromine floater.

Water level is very important to the operation of your spa. If the water level is too low or too high, your spa will not operate properly. The water level should be about six inches from the top when the spa is not being used.

Maintenance Schedule

Each time you refill the spa	Follow the section "Starting the Spa with Fresh Water".
Prior to each use	Test the spa water using either test strips a reagent test kit. Adjust chemical levels as necessary.
Once a week	Test the spa water using either test strips a reagent test kit. Adjust chemical levels as necessary.
Once a month	Deep clean your spa's filter. (Follow filter cleaning instruction at beginning of Clear Water Plan)
Every two to four months	<p>Drain and clean your spa with multi-purpose cleaner.</p> <p>Polish the acrylic surface with a surface protectant.</p> <p>Clean and treat spa cover, pillows, and Cal Select cabinet (if equipped).</p> <p>Refill your spa, following the section "Starting the Spa with Fresh Water".</p>
Once a year	Replace filter cartridges if the pleats appear frayed.

We recommend that your spa water be changed every 4 to 6 months. You may find the need to change your spa water more frequently with heavy use. When empty, your spa should be cleaned with a non-abrasive all-surface cleaner, and then rinsed thoroughly.

Cleaning and Maintenance

Removing and Reseating the Pillows

You can remove the pillows for cleaning and maintenance quickly and easily. This method works for all types of pillows.

Grab the lower edge of the pillow with both hands firmly and pull up. As you do this, the pillow inserts will pop out of the holes.



Reseat the pillows by aligning the pillow inserts with the holes and striking the pillow hard enough to insert the pegs back into the holes.



Spa Cover

Important! Keep the spa covered when not in use!

- Covered spas will use less electricity in maintaining your set temperature.
- Covering your spa will protect your spa's finish from the sun's ultraviolet rays.
- You are required to keep the spa covered to maintain warranty coverage.
- Covering your spa helps prevent children from drowning in the spa.

See the manual enclosed with your cover for instructions on mounting the locks and how to lock and unlock the cover.

In addition, while the spa cover is rigid, it is not designed to support any weight. Therefore, as a safety precaution and to preserve the life of your cover, you must not sit, stand, or lie on it; nor should you place objects of any kind on top of it.

Draining Your Spa

Your spa should be drained every four to six months, and refilled with fresh tap water. The following is the recommended method for draining your spa.

1. Turn off the power at the breaker.
2. Remove all filters.
3. Hook up the female end of a garden hose to the drain fitting (if equipped).
4. Place the other end of the garden hose where you would like the water to drain to.
5. Let spa drain completely, then remove garden hose and refill.

Cleaning and Replacing the Filter

Filtration is one of the most important steps you can take to ensure clean, clear water. It is far less expensive to fix water clarity problems by filtering your spa than by using excessive amounts of chemicals, excessive filtration times, or by water replacement.

See the section "Clear Water Plan" for more information on cleaning your filter.

Winterizing (Cold Climate Draining)

In many areas of the country, the temperature drops below 32°F (0°C). We recommend that you always have your spa full of water and running at normal spa temperatures (80°F to 100°F, 26.7°C to 37.8°C). This will help reduce the risk of freezing in your spa and your spa's equipment.

WARNING: If you find the need to drain your spa, please be aware of the potential of freezing in your spas equipment and plumbing. Even if the directions below are followed perfectly, there is no guarantee that your spa will not suffer freeze damage and thereby void the warranty coverage.

1. Open all filter covers.
2. Remove the filter baskets and filters.
3. Drain your spa completely as described in the instructions above.
4. Remove drain plugs from the front of the pumps.
5. Disconnect the unions from both sides of the pump.
6. Use a wet/dry vacuum to blow any remaining water out of the jets and equipment area.

Cover your spa with a good spa cover and an all-weather tarp to ensure that neither rain nor snow enters the spa.

Cleaning Your Spa

Spa Cover and Pillows

Due to the constant punishment your spa cover and pillows receive, you should protect them by applying a vinyl and leather cleaner as part of your monthly maintenance plan. Use a product that is specifically designed to protect spa covers and pillows from chemical and ultraviolet light damage without leaving an oily residue behind that is normally associated with common automotive vinyl protectants.

Warning: *Do not* use automotive vinyl protectants on spa covers or pillows. These products are generally oil-based and will cause severe water clarity issues that are difficult to correct.

Spa Shell

Each time you drain your spa, before you refill it you should clean your spa shell with an all-purpose cleaner and apply a coat of surface protectant.



Use a low detergent, non-abrasive cleaner specifically formulated to clean the spa without damaging its acrylic finish.

Use a non-oil based surface protectant that is specifically formulated to protect the spa's finish from the chemicals and minerals associated with normal spa use.

Appendix

Replacement Parts

Jets	
ELE 2" Euro No Eyeball PLU282050W	
mfc 3" Directional PLU283050W	
PSR 5" Rim PLU285052W	
SW Swim Standard face PLU21700565	

Lights	
Light Inground 100W 120V 30' LIT16000100	
Walfitting, Clear Lens Cap, Jumbo Spa Light, 5" LIT16100153	
Red Lens Insert, Jumbo Spa Light LIT16100155	
Blue Lens Insert, Jumbo Spa Light LIT16100156	

Covers							
	Deluxe Rust	Deluxe Gray	Deluxe Slate	Deluxe Palomino	Deluxe Teal	Deluxe Navy	Deluxe Hunter
DIJ-401 93" Round	ACU02200310	ACU02200311	ACU02200315	ACU02200316	ACU02200312	ACU02200313	ACU02200314
DIJ-405 93 x 130	ACU02200540	ACU02200541	ACU02200542	ACU02200543	ACU02200544	ACU02200545	ACU02200546
DIJ-407 93 x 200	ACU02200300	ACU02200301	ACU02200305	ACU02200306	ACU02200302	ACU02200303	ACU02200304

Warranty

Cal Spas Designer Inground Spas do not come with a warranty. If you have any questions, contact Cal Spas customer service at 1-800-CAL-SPAS.



LMS Customer Service Department
1462 East Ninth Street
Pomona, CA 91766

Toll Free: 1-800-CAL-SPAS
Fax: 1-909-629-3890

www.calspas.com