

Owner's Manual

CRAFTSMAN®

2.7 HP (Maximum Developed)
10" Inch Blade
5000 R.P.M.

TABLE SAW

Model No.
137.218250

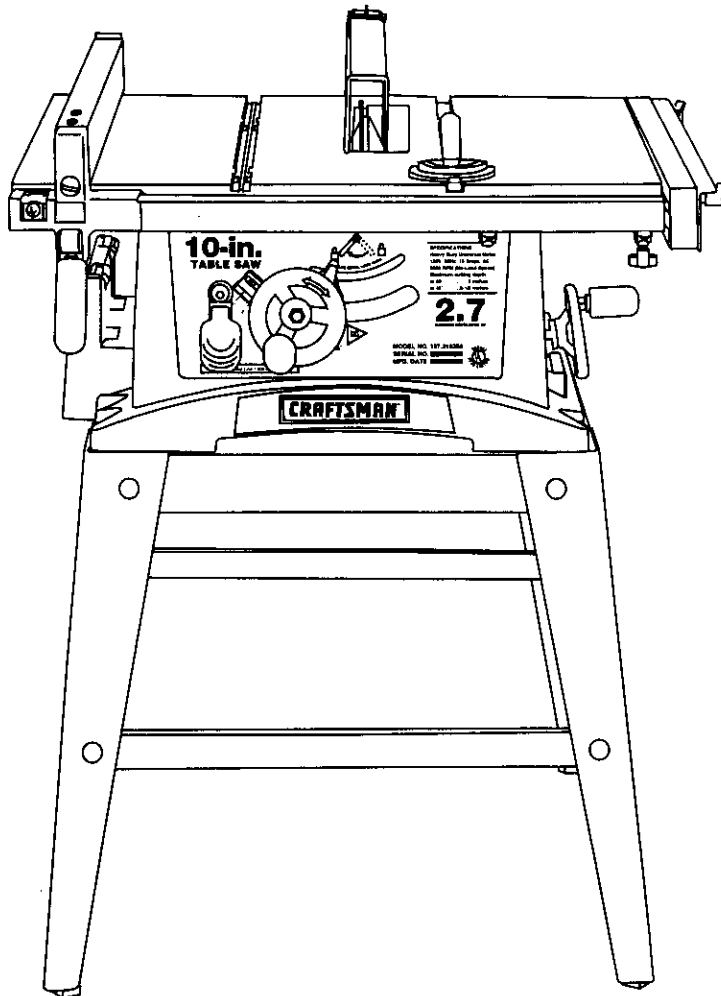

CAUTION:

Before using this Table Saw, read this manual and follow all its Safety Rules and Operating Instructions.

- Safety Instructions
- Installation
- Operation
- Maintenance
- Parts List
- Español

Customer Help Line
1-800-843-1682

Sears, Roebuck and Co., Hoffman Estates, IL 60179 USA
Part No. 137218250001

TABLE OF CONTENTS

SECTION	PAGE
Warranty	2
Product Specifications	2
Safety Instructions	3
Accessories and Attachments	6
Tools needed for assembly	6
Carton Contents	6
Know Your Table Saw	8
Assembly and Adjustments	9
Operation	16
Maintenance	20
Troubleshooting guide	21
Parts	22
Making a push stick	33
Español	37

WARRANTY

FULL ONE YEAR WARRANTY

If this product fails due to a defect in material or workmanship within one year from the date of purchase, Sears will repair it free of charge.

Contact a Sears Service Center for repair.

If this product is used for commercial or rental purposes, this warranty applies only for 90 days from the date of purchase.

This warranty gives you specific legal rights, and you may also have other rights which vary from state to state.

Sears, Roebuck and Co., Dept. 817 WA, Hoffman Estates, IL 60179

PRODUCT SPECIFICATIONS

MOTOR

HP (Maximum developed)	2.7
Type	Universal
Amps	15
Voltage	120
Hz	60
RPM (no load)	5000
Overload Protection	YES

▲ WARNING

To avoid electrical hazards, fire hazards, or damage to the tool, use proper circuit protection.

Your table saw is wired at the factory for 120V operation. Connect to a 120V, 15 AMP branch circuit and use a 15 AMP time delay fuse or circuit breaker. To avoid shock or fire, replace power cord immediately if it is worn, cut or damaged in any way.

SAW

Table	26-7/64" x 19-3/32"
Table extension	Yes, with fence
Extension fence capacity	24"
Blade	10"
Rip scale	YES
Rip fence	YES
Miter gauge	YES
Leg set	YES
Maximum Depth of cut at 90°	3"
Maximum Depth of cut at 45°	2-1/2"
Maximum Dado cut width	1/2"
Net weight	61.6 Lbs.

SAFETY

GENERAL SAFETY INSTRUCTIONS

BEFORE USING THE TABLE SAW

Safety is a combination of common sense, staying alert and knowing how to use your table saw.

⚠ WARNING

To avoid mistakes that could cause serious injury, do not plug the table saw in until you have read and understood the following:

1. **READ** and become familiar with this entire instruction manual. **LEARN** the tool's applications, limitations, and possible hazards.
2. **KEEP GUARDS IN PLACE** and in working order.
3. **REMOVE ADJUSTING KEYS AND WRENCHES.** Form the habit of checking to see that keys and adjusting wrenches are removed from the tool before turning ON.
4. **KEEP WORK AREA CLEAN.** Cluttered areas and benches invite accidents.
5. **DON'T USE IN A DANGEROUS ENVIRONMENT.** Don't use power tools in damp or wet locations, or expose them to rain. Keep work area well lighted.
6. **KEEP CHILDREN AWAY.** All visitors should be kept at a safe distance from the work area.
7. **MAKE WORKSHOP KID PROOF** with padlocks, master switches, or by removing starter keys.
8. **DON'T FORCE THE TOOL.** It will do the job better and safer at the rate for which it was designed.
9. **USE THE RIGHT TOOL.** Don't force tool or the attachment to do a job for which it was not designed.
10. **USE PROPER EXTENSION CORD.** Make sure your extension cord is in good condition. When using an extension cord, be sure to use one heavy enough to carry the current your product will draw. An undersized cord will cause a drop in line voltage resulting in loss of power and overheating. The table on page 5 shows the correct size to use depending on cord length and nameplate ampere rating. If in doubt, use the next heavier gauge. The smaller the gauge number, the heavier the cord.
11. **WEAR PROPER APPAREL.** DO NOT wear loose clothing, gloves, neckties, rings, bracelets, or other jewelry which may get caught in moving parts. Non-slip footwear is recommended. Wear protective hair covering to contain long hair.
12.  **ALWAYS WEAR EYE PROTECTION.** Any table saw can throw foreign objects into the eyes which could cause permanent eye damage. **ALWAYS** wear Safety Goggles (not glasses) that comply with ANSI safety standard Z87.1. Everyday eyeglasses have only impact-resistant lenses. They **ARE NOT** safety glasses. Safety Goggles are available at Sears. **NOTE:** Glasses or goggles not in compliance with ANSI Z87.1 could seriously hurt you when they break.
13. **WEAR A FACE MASK OR DUST MASK.** Sawing operation produces dust.
14. **SECURE WORK.** Use clamps or a vise to hold work when practical. It's safer than using your hand and it frees both hands to operate tool.
15. **DISCONNECT TOOLS** before servicing, and when changing accessories, such as blades, bits, cutters, and the like.
16. **REDUCE THE RISK OF UNINTENTIONAL STARTING.** Make sure the switch is in OFF position before plugging in.
17. **USE RECOMMENDED ACCESSORIES.** Consult the owner's manual for the recommended accessories. The use of improper accessories may cause risk of injury to persons.
18. **NEVER STAND ON TOOL.** Serious injury could occur if the tool is tipped or if the cutting tool is unintentionally contacted.
19. **CHECK FOR DAMAGED PARTS.** Before further use of the tool, a guard or other part that is damaged should be carefully checked to determine that it will operate properly and perform its intended function. Check for alignment of moving parts, binding of moving parts, breakage of parts, mounting, and any other conditions that may affect its operation. A guard or other part that is damaged should be properly repaired or replaced.
20. **NEVER LEAVE TOOL RUNNING UNATTENDED. TURN THE POWER OFF.** Don't leave the tool until it comes to a complete stop.
21. **DON'T OVERREACH.** Keep proper footing and balance at all times.
22. **MAINTAIN TOOLS WITH CARE.** Keep tools sharp and clean for best and safest performance. Follow instructions for lubricating and changing accessories.
23. **DIRECTION OF FEED.** Feed work into a blade or cutter against the direction of rotation of the blade or cutter only.

SAVE THESE INSTRUCTIONS

24. **WARNING:** Dust generated from certain materials can be injurious to your health. Always operate saw in well ventilated areas and provide for proper dust removal.

SPECIFIC SAFETY INSTRUCTIONS FOR THE TABLE SAW

1. **ALWAYS USE SAW BLADE GUARD** spreader and anti-kickback pawls for every operation for which they can be used, including through-sawing. Through-sawing operations are those in which the blade cuts completely through the workpiece when ripping or cross-cutting.
2. **ALWAYS HOLD THE WORK FIRMLY** against the miter gauge or rip fence.
3. **USE A PUSH STICK** when required. Always use a push stick for ripping narrow stock. Refer to ripping applications in the instruction manual where the push stick is covered in detail. See the push stick pattern included in this Owner's Manual.
4. **NEVER PERFORM ANY OPERATION "FREE HAND"**, which means using your hands only to support or guide the workpiece. Always use either the fence or the miter gauge to position and guide the work.
5. **NEVER STAND** or have any part of your body in line with the path of the saw blade. Keep your hands out of the line of the saw blade.
6. **NEVER REACH** behind or over the cutting tool for any reason.
7. **REMOVE** the rip fence when cross-cutting.
8. **DO NOT USE** molding head set with this saw.
9. **FEED WORK INTO THE BLADE** against the direction of rotation only.
10. **NEVER** use the fence as a cut-off gauge when cross-cutting.
11. **NEVER ATTEMPT TO FREE A STALLED SAW BLADE** without first turning the saw OFF. Turn power switch OFF immediately to prevent motor damage.
12. **PROVIDE ADEQUATE SUPPORT** to the rear and sides of the saw table for wide or long workpieces.
13. **AVOID KICKBACKS** (work thrown back towards you) by keeping the blade sharp, keeping the rip fence parallel to the saw blade, and by keeping the spreader, anti-kickback pawls, and guard in place and functioning. Do not release work before it is pushed all the way past the saw blade. Do not rip work that is twisted, warped, or does not have a straight edge to guide along the fence.
14. **AVOID AWKWARD OPERATIONS** and hand positions where a sudden slip could cause your hand to move into the cutting tool.
15. **NEVER USE SOLVENTS** to clean plastic parts. Solvents could possibly dissolve or otherwise damage the material. Only a soft damp cloth should be used to clean plastic parts.
16. **MOUNT** your table saw before performing any cutting operations. Refer to installation instructions.
17. **NEVER CUT METALS** or materials which may make hazardous dust.
18. **ALWAYS USE IN A WELL VENTILATED AREA.** Remove sawdust frequently. Clean out sawdust from the interior of the saw to prevent a potential fire hazard.
19. **NEVER LEAVE THE TOOL** running unattended. Don't leave the tool until it comes to a complete stop.
20. For proper operation follow the instructions of this owner's manual titled "**SAW MOUNTED TO WORK SURFACES.**" Failure to provide sawdust fall-through and removal hole will allow sawdust to build up in the motor area, which may result in a fire hazard or cause motor damage.
21. **ALWAYS USE THE TABLE EXTENSION** for support when cutting a long workpiece. Never use an unstable surface or another person to hold a long workpiece. Adjust the table extension for maximum stability and length of the workpiece before cutting.
22. **ALWAYS LOCK THE TABLE EXTENSION** securely in place before cutting workpiece.

ELECTRICAL REQUIREMENTS

POWER SUPPLY AND MOTOR SPECIFICATIONS

▲ WARNING

To avoid electrical hazards, fire hazards, or damage to the tool, use proper circuit protection. Use a separate electrical circuit for your tools. Your saw is wired at the factory for 120V operation. Connect to a 120V, 15 Amp circuit and use a 15 Amp time delay fuse or circuit breaker. To avoid shock or fire, if power cord is worn or cut, or damaged in any way, have it replaced immediately.

SAVE THESE INSTRUCTIONS

GROUNDING INSTRUCTIONS

IN THE EVENT OF A MALFUNCTION OR BREAKDOWN, grounding provides a path of least resistance for electric current and reduces the risk of electric shock. This tool is equipped with an electric cord that has an equipment grounding conductor and a grounding plug. The plug **MUST** be plugged into a matching receptacle that is properly installed and grounded in accordance with ALL local codes and ordinances.

DO NOT MODIFY THE PLUG PROVIDED. If it will not fit the receptacle, have the proper receptacle installed by a qualified electrician.

IMPROPER CONNECTION of the equipment grounding conductor can result in risk of electric shock. The conductor with the green insulation (with or without yellow stripes) is the equipment grounding conductor. If repair or replacement of the electric cord or plug is necessary, **DO NOT** connect the equipment grounding conductor to a live terminal.

CHECK with a qualified electrician or service person if you do not completely understand the grounding instructions, or if you are not sure the tool is properly grounded.

USE A SEPARATE ELECTRICAL CIRCUIT for your tools. This circuit must not be less than #12 wire and should be protected with a 15 Amp time delay fuse. Before connecting the motor to the power line, make sure the switch is in the OFF position and the electric current is rated the same as the current stamped on the motor nameplate. Running at a lower voltage will damage the motor.

This tool is intended for use on a circuit that has a receptacle like the one illustrated in FIGURE A. **FIGURE A** shows a 3-prong electrical plug and receptacle that has a grounding conductor. If a properly grounded receptacle is not available, an adapter (**FIGURE B**) can be used to temporarily connect this plug to a 2-contact ungrounded receptacle. The temporary adapter should be used only until a properly grounded receptacle can be installed by a qualified technician. The adapter (**FIGURE B**) has a rigid lug extending from it that **MUST** be connected to a permanent earth ground, such as a properly grounded receptacle box. The Canadian Electrical Code prohibits the use of adapters.

CAUTION: In all cases, make certain the receptacle is properly grounded. If you are not sure have a qualified electrician check the receptacle.

⚠ WARNING

This table saw is for indoor use only. Do not expose to rain or use in damp locations.

Fig. A

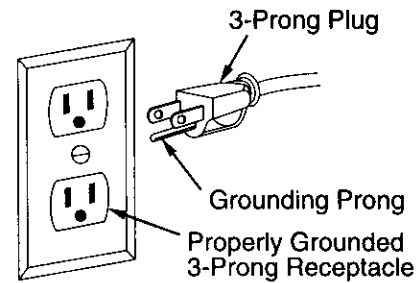
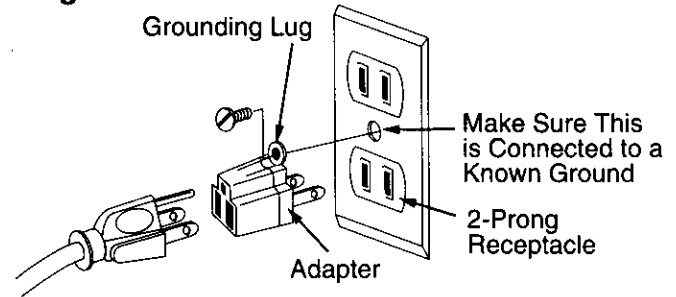

Fig. B



GUIDELINES FOR EXTENSION CORDS

USE ONLY 3-wire extension cords that have 3-prong grounding plugs and 3-pole receptacles that accept the tool's plug. Repair or replace damaged or worn cord immediately.

USE PROPER EXTENSION CORD. Make sure your extension cord is in good condition. When using an extension cord, be sure to use one heavy enough to carry the current your product will draw. An undersized cord will result in a drop in line voltage and in loss of power which will cause the tool to overheat. The table below shows the correct size to use depending on cord length and nameplate ampere rating. If in doubt, use the next heavier gauge. The smaller the gauge number, the heavier the cord.

Be sure your extension cord is properly wired and in good condition. Always replace a damaged extension cord or have it repaired by a qualified person before using it. Protect your extension cords from sharp objects, excessive heat and damp or wet areas.

⚠ WARNING

This tool must be grounded while in use to protect the operator from electrical shock.

MINIMUM GAUGE FOR EXTENSION CORDS (AWG)					
(when using 120 volts only)					
Ampere Rating		Total length of cord in feet			
more than	not more than	25'	50'	100'	150'
0	6	18	16	16	14
6	10	18	16	14	12
10	12	16	16	14	12
12	16	14	12	Not Recommended	

SAVE THESE INSTRUCTIONS

ACCESSORIES AND ATTACHMENTS

RECOMMENDED ACCESSORIES

Visit your Sears Hardware Department or see the Craftsman Power and Hand Tools Catalog to purchase recommended accessories for this power tool.

▲ WARNING

To avoid the risk of personal injury:

- Do not use adjustable (wobble) type dados or carbide tipped dado blades, maximum dado width is 1/2".
- Do not use a dado with a diameter larger than 6".
- Do not use molding head set with this saw.
- Do not modify this power tool or use accessories not recommended by Sears.

TOOLS NEEDED FOR ASSEMBLY

TOOLS NEEDED

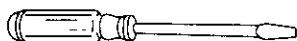

Medium screwdriver



#2 Phillips screwdriver

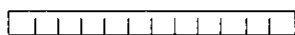

Straight edge



Adjustable wrench



Combination square

CARTON CONTENTS

UNPACKING AND CHECKING CONTENTS

Separate all parts from packing material. Check each one with the illustration and the list of loose parts to make certain all items are accounted for, before discarding any packing material.

▲ WARNING

To avoid personal injury, if any parts are missing, do not attempt to assemble the table saw, plug in the power cord, or turn the switch on until the missing parts are obtained and are installed correctly.

TABLE OF LOOSE PARTS

ITEM	DESCRIPTION	QUANTITY
SAW		
A.	Table saw	1
B.	Blade guard and splitter	1
C.	Bolt, flat washer, toothed washer, oval washer	1 each
D.	Rip fence handle	1
E.	Rip fence	1
F.	Hand wheels	2
G.	Dome nuts	2
H.	Dado table insert	1
I.	Miter gauge	1
J.	Hex keys	2
K.	Blade wrenches	2
STAND		
L.	Top bracket (short)	2
M.	Top bracket (long)	2
N.	Bottom bracket (short)	2
O.	Bottom bracket (long)	2
P.	Legs	4
Q.	Bag of bolts, nuts, foot pads	1

NOTE: To make assembly easier, keep contents of box together. Apply a coat of automobile wax to the table. Wipe all parts thoroughly with a clean dry cloth. This will reduce friction when pushing the workpiece.

UNPACKING YOUR TABLE SAW:

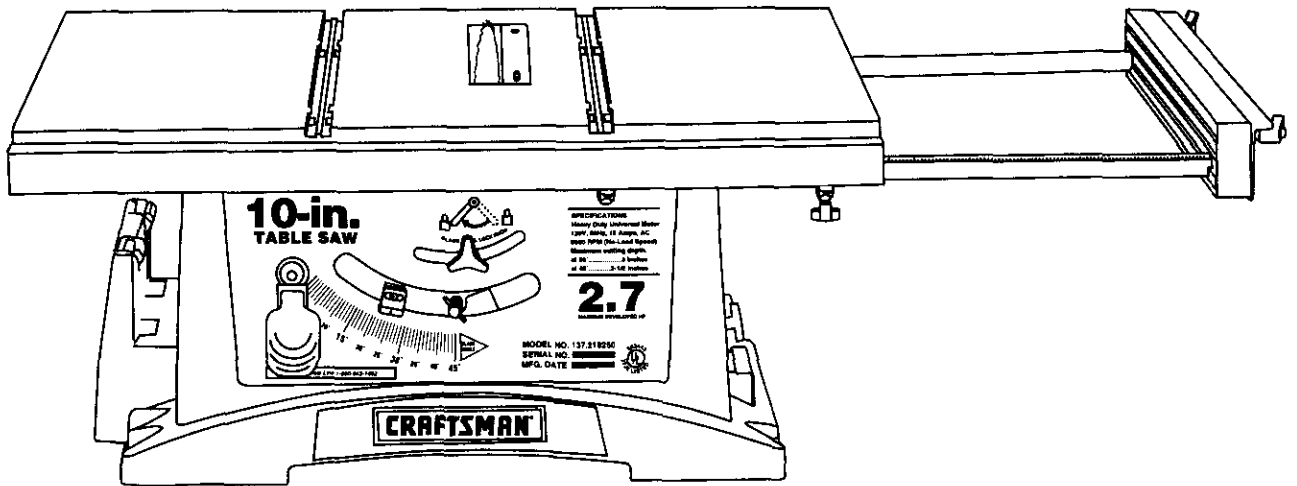

A.

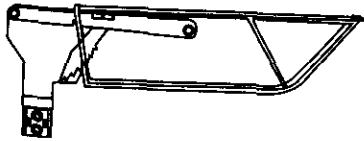

B.

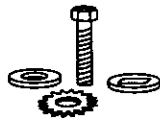

C.



D.

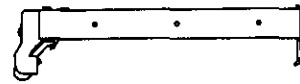

E.

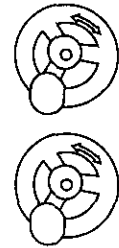

F.



G.

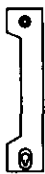

H.

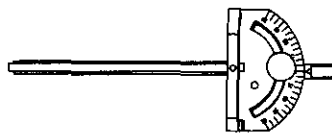

I.



J.



K.

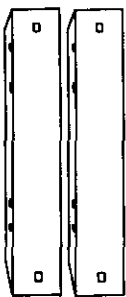

L.



M.



N.



O.

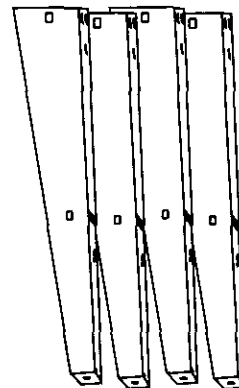

P.

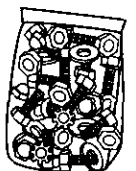

Q.

KNOW YOUR TABLE SAW

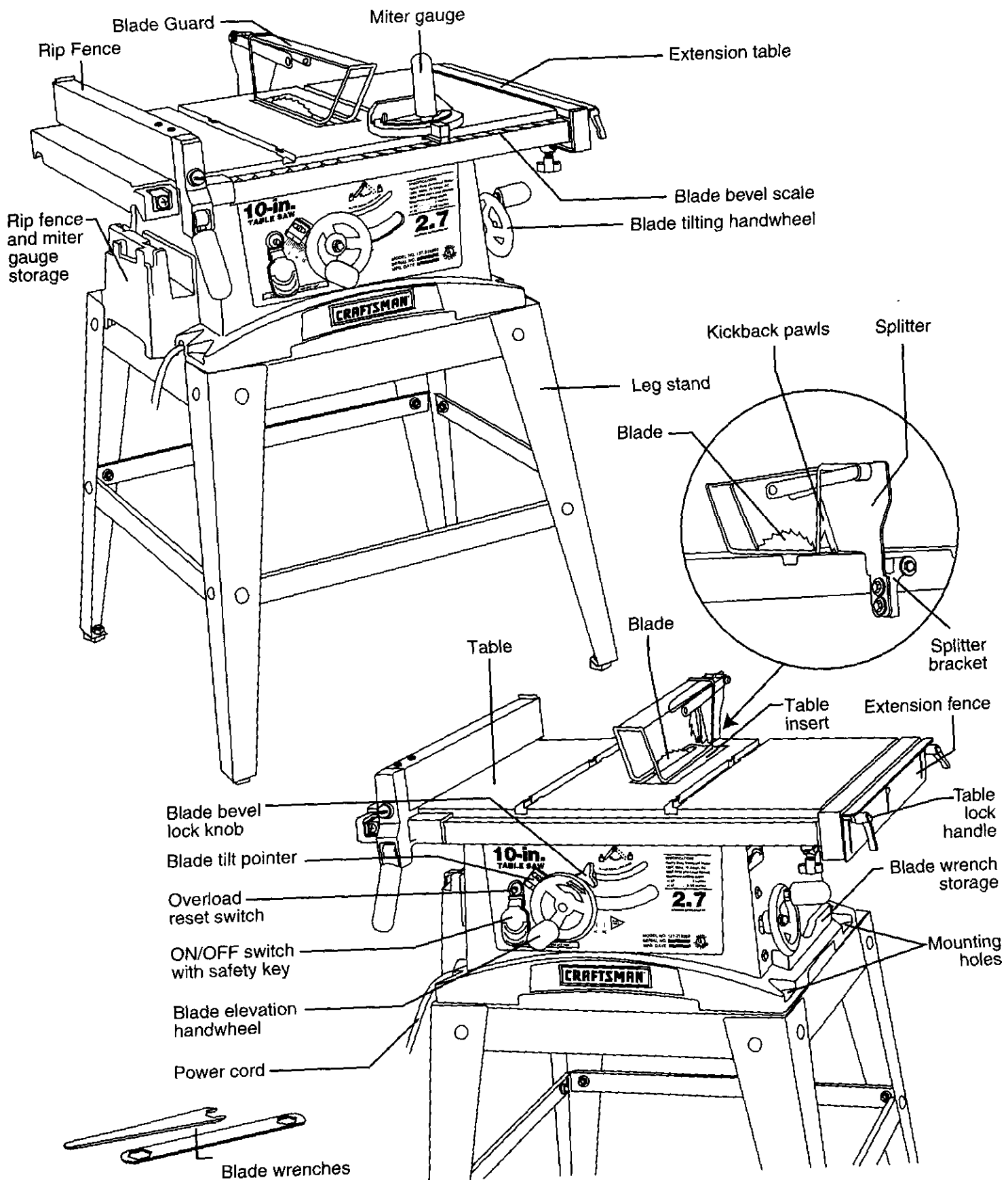

ASSEMBLY AND ADJUSTMENTS

ASSEMBLY INSTRUCTIONS

▲ WARNING

For your own safety, never connect plug to power source outlet until all assembly steps are complete, and you have read and understood the safety and operating instructions.

LEG SET (FIG. A)

1. Separate all parts and group by size and style.

NOTE: Finger tighten bolts and nuts when joining parts.

2. Use bolts (1), washers (2), and nuts (3) to assemble the leg set parts.
3. Attach a leg (4) to the long top bracket (5). Attach the next leg to the opposite end of the top bracket.
4. Repeat this assembly for the opposite side of the leg set.
5. Attach the completed leg set assemblies to the short top brackets (6). Repeat on the opposite side.
6. Insert bolt (7) into the recessed hole of the foot pad (8).
7. Insert into the leg flange hole and tighten, using washer (9) and nut (10). Repeat for the three other legs.
8. Attach the bottom brackets (11) between each leg.
9. Place the leg set on a level surface and tighten all nuts and bolts.

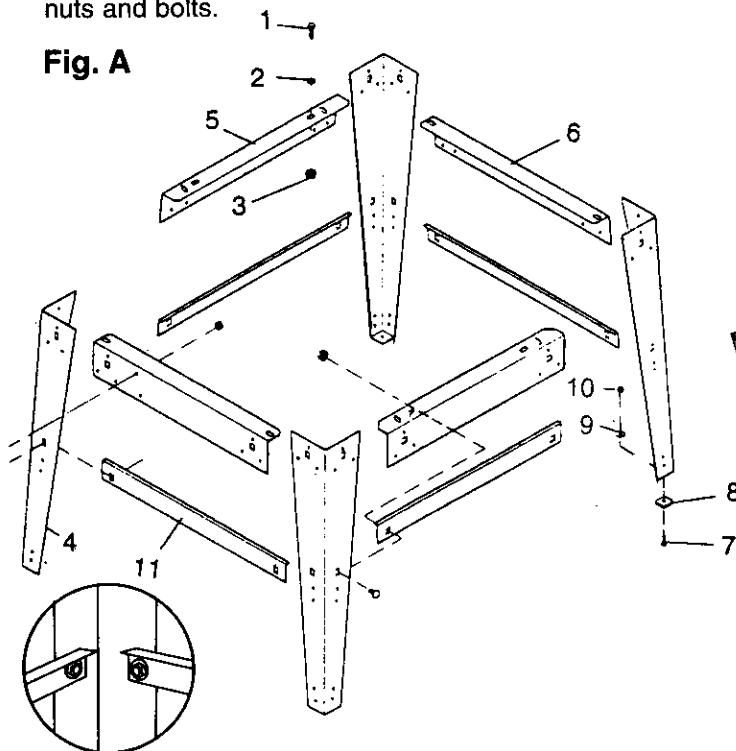

SAW TO LEG SET (FIG. B)

1. Before mounting the blade guard, the rip fence and miter gauge to the saw top, invert the saw table so that it is facing the floor.
2. Position the leg set upside down on the saw base.
3. Match the holes of the stand to the holes on the bottom flange of the saw base.
4. Secure the leg set to the saw base using bolts, washers, and nuts.
5. When all bolts and nuts are tightened, carefully set the saw in its upright position.
6. Position the saw on a clean, level surface.

Fig. B

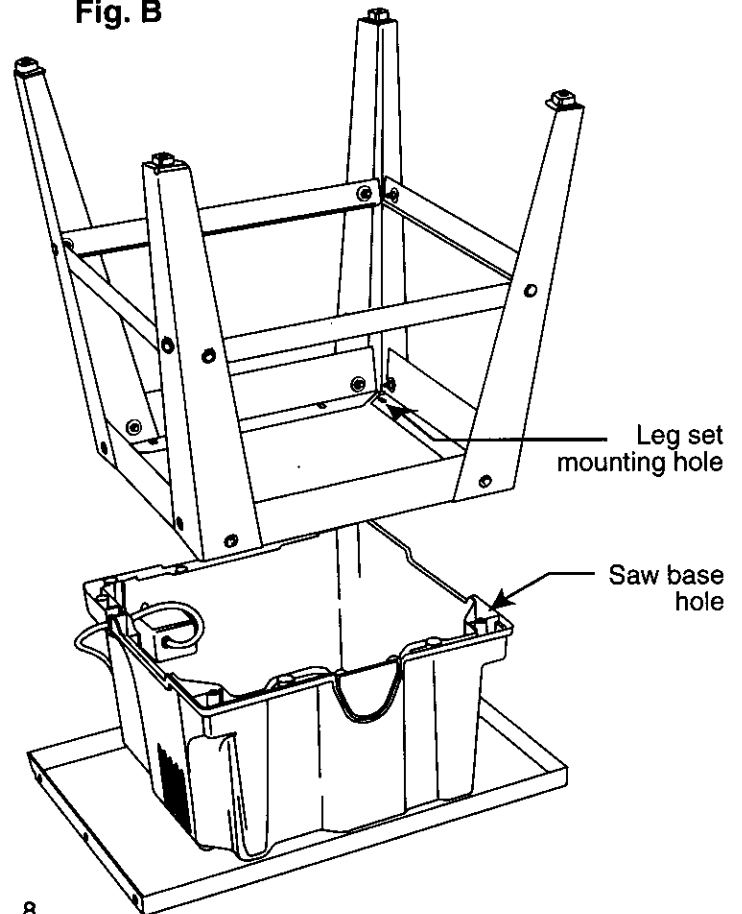

SAW MOUNTED TO OTHER WORK SURFACES (FIG. C)

1. If the leg set will not be used the saw must be properly secured to a sturdy workbench using the four mounting holes at the base of the saw.
2. The surface of the table where the saw is to be mounted must have a hole large enough to facilitate sawdust fall-through and removal.
3. Square the saw on the mounting surface and mark the location of the four 3/8" mounting holes (1).
4. Drill 3/8" holes into the mounting surface.
5. Mark a 12" to 14" square (2) centered between the four mounting holes (1).
6. Cut out and remove the square.
7. This opening will allow sawdust to fall through the saw base.
8. Place the saw on the work surface, and align the mounting holes of the saw with those drilled through the surface.
9. Fasten the saw to the work surface.

Fig. C

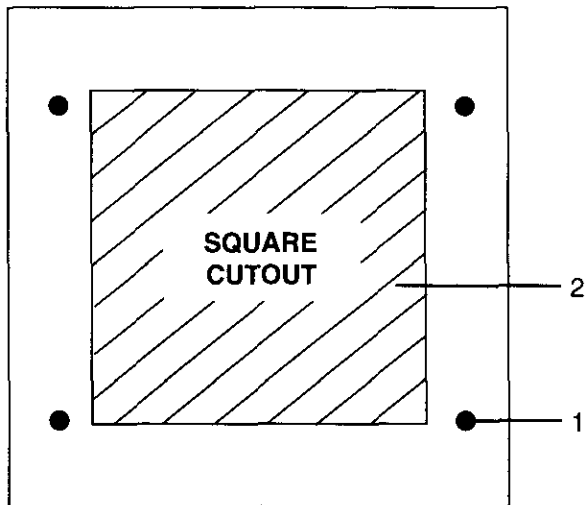

⚠ WARNING

Failure to provide the sawdust fall-through hole will cause sawdust to build up in the motor area, which may result in fire or cause motor damage.

KEEPING THE AREA CLEAN (FIG. D)

1. Sawdust and wood chips that fall from under the saw will accumulate on the floor.
2. Make it a practice to pick up and discard this dust when you have completed cutting.

⚠ WARNING

Always keep your work area clean, uncluttered and well lit. Do not work on floor surfaces that are slippery from sawdust or wax.

Fig. D

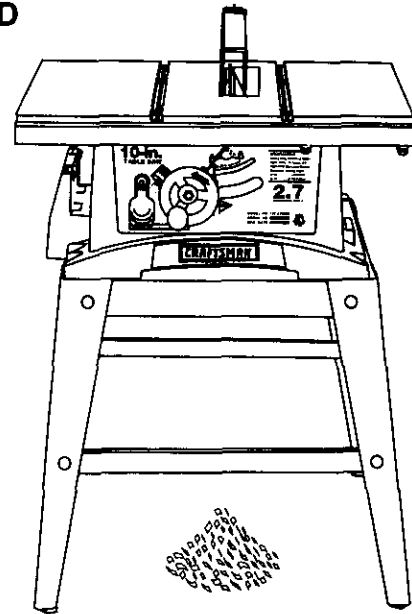

BLADE RAISING HANDWHEEL (FIG. E, F)

1. Attach the handwheel (1) to the elevation screw (2) at the front of the saw. Make sure the slots (3) in the hub of the handwheel engage with the pins (4). (FIG. E)
2. Attach and tighten the dome nut (5) at the end of the shaft (FIG. F).

Fig. E

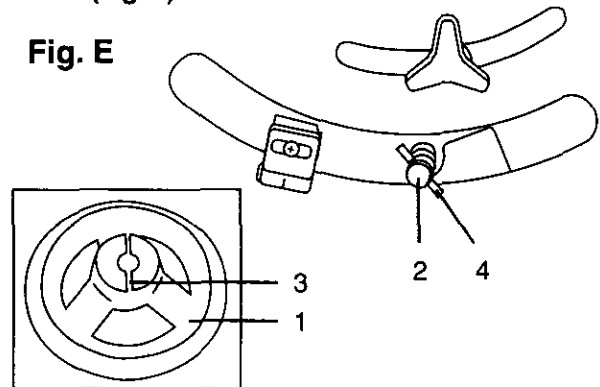

BLADE TILTING HANDWHEEL (FIG. F)

1. Attach the other handwheel (6) to the blade tilting screw on the side of the saw in the same manner as above.
2. Attach and tighten the handwheel dome nut (5).

Fig. F

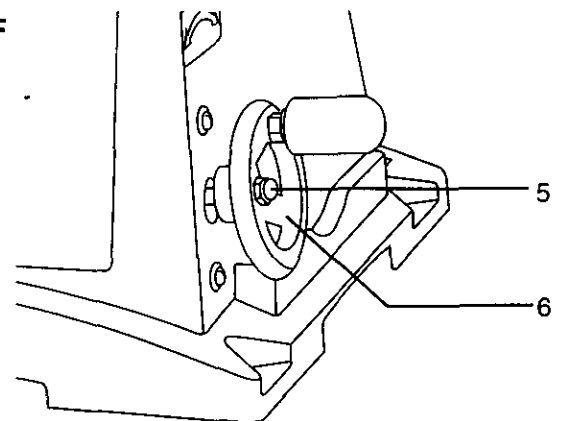

RIP FENCE (FIG. G)

1. Thread the fence handle (1) into the cam hole (2) until tight.
2. Lift upward on the rip fence handle so that the holding clamp (3) is fully extended.
3. Place the rip fence on the saw table and engage the holding clamp to the table rear. Lower the front end onto the front rail (4).
4. Push down on the fence handle to lock.

Fig. G

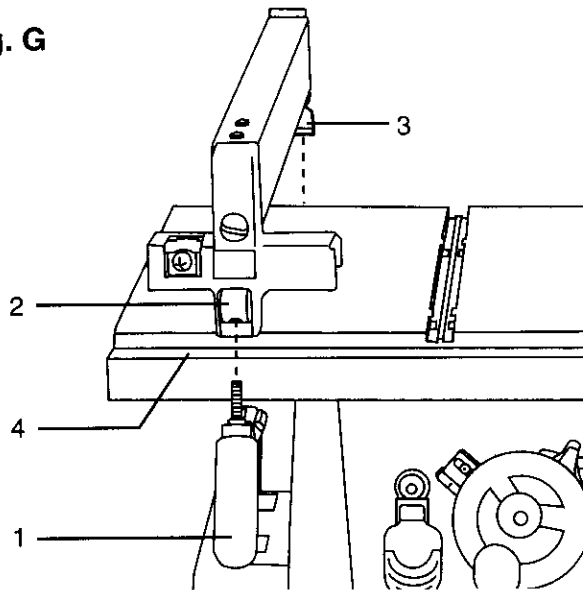

CHANGING THE BLADE (FIG. H, I, J)

▲ WARNING

To avoid injury from an accidental start, make sure the switch is in the OFF position and the plug is not connected to the power source outlet.

1. Remove the table insert (1) by unscrewing the two screws (2, 3). Be careful not to lose the rubber washer that is on the back screw (3) beneath the table insert. (FIG. H)

NOTE: The back screw is longer than the front screw.

Fig. H

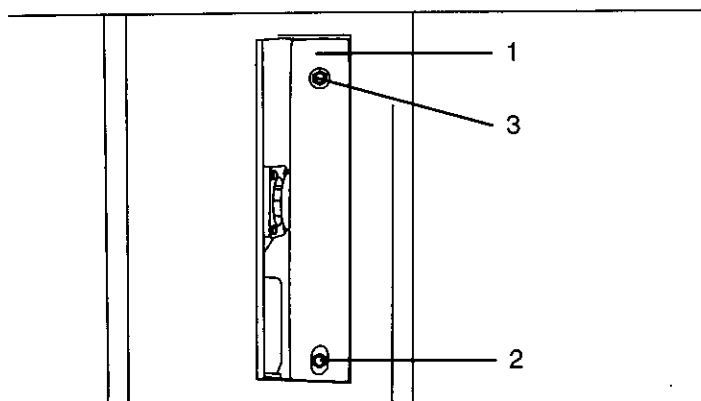

2. Raise the blade arbor (4) (FIG. I) to the maximum height by turning the blade-raising handwheel counterclockwise.
3. Remove the arbor nut (5) and flange (6), remove blade.
4. Install the new saw blade onto the arbor with the blade teeth pointing toward the front of the saw.
5. Install the flange (6) against the blade and thread the arbor nut (5) as far as possible by hand. Ensure that the blade is flush against the inner side of the blade flange.

▲ WARNING

To avoid possible injury and damage to the workpiece be sure to install the blade with the teeth pointing toward the front of the table in the direction of the rotation arrow on the blade guard.

Fig. I

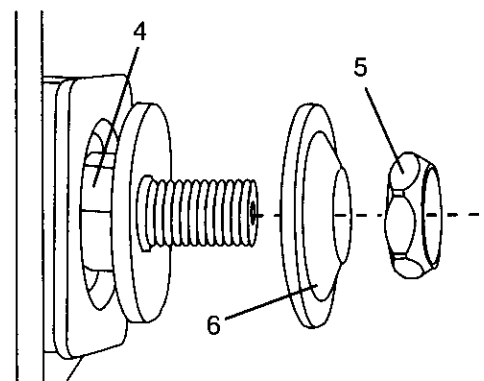

6. To tighten the arbor nut (5) place the open end wrench jaws on the flats of the blade arbor to keep the arbor from turning. (FIG. J)
7. Place the box-end wrench (8) on the arbor nut (5), and turn clockwise (to the rear of the saw table.)
8. Replace the blade insert in the table recess, insert the screws through the front and rear holes and tighten.

Fig. J

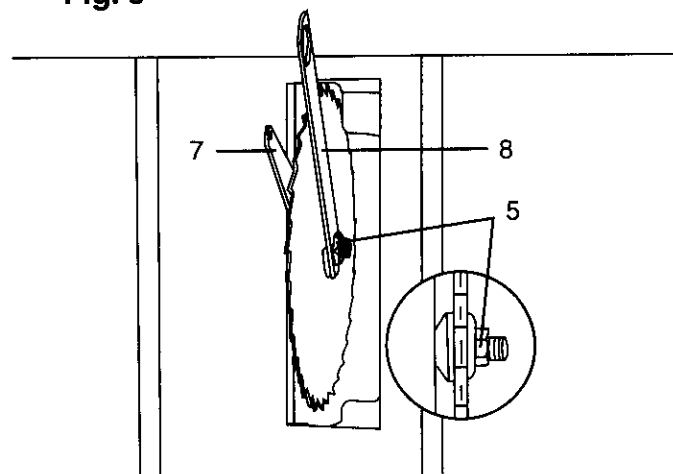

▲ WARNING

To avoid injury from a thrown workpiece, blade parts, or blade contact, never operate saw without the proper insert in place. Use the saw blade insert when sawing. Use the dado head insert when using a dado.

BLADE GUARD ASSEMBLY (FIG. K, L, M)

1. Set the blade to maximum height and the tilt to zero degrees on the bevel scale with the hand wheels. Lock the blade lock knob.
2. Place the external toothed lock washer (1) and a steel flat washer (2) onto the long hex. head bolt (3). Insert the bolt into the splitter bracket (4) as shown. (FIG. K)

Fig. K

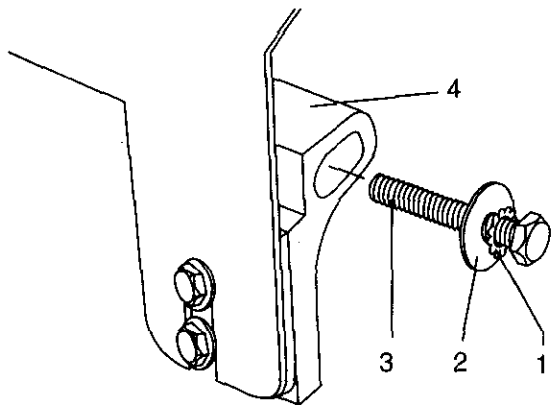

3. Place the oval washer (5) on the pivot rod (6). (FIG. L)
4. Install the bracket assembly (4) into the rear of the saw table. Thread the bolt (3) into the internally threaded pivot rod.

NOTE: The splitter is removed from the illustration for clarity.

Fig. L

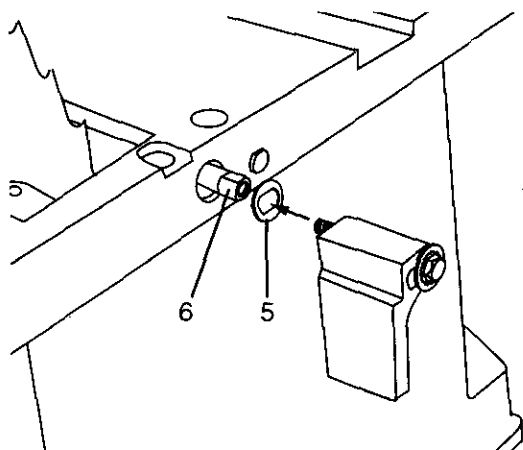

5. Position the blade guard arm (7) to the rear of the table. (FIG. M)
6. Using a straightedge, check that the blade guard splitter (8) is aligned with the saw blade (9).
7. If straightening adjustment is necessary, loosen the bolt (3) and shift the splitter assembly to the right or left, or rotate.
8. When the splitter is properly aligned with the saw blade, tighten the bolt.

NOTE: The splitter must always be correctly aligned so the cut workpiece will pass on either side without binding or twisting to the side.

Fig. M

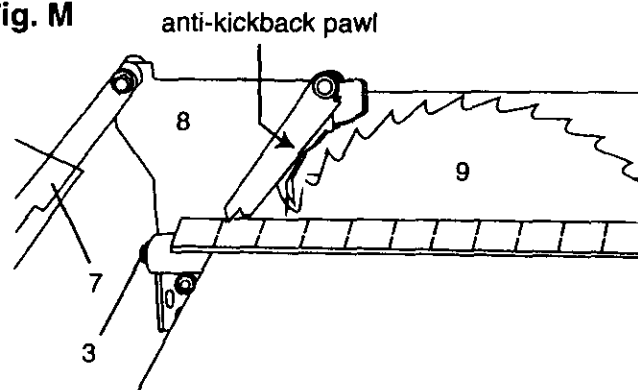

ADJUSTMENT INSTRUCTIONS

▲ WARNING

To avoid injury from an accidental start, make sure the switch is in the OFF position and the plug is not connected to the power source, before making any adjustments.

ADJUSTING THE TABLE EXTENSION (FIG. O)

NOTE: The table extension may be installed on the right side of the table, as needed, to support long workpieces.

To adjust the table extension position (FIG. O):

1. Loosen the two clamp bolts (4) on the two extension tube brackets.
2. Slide the extension tubes in or out until the scale on the front tube is positioned at the desired distance.
3. Tighten the two lock handles.

To adjust the extension table fence:

1. Loosen the locking handle (5) on the fence (6).
2. Raise the fence to the desired height and tighten the locking handle.

Fig. O

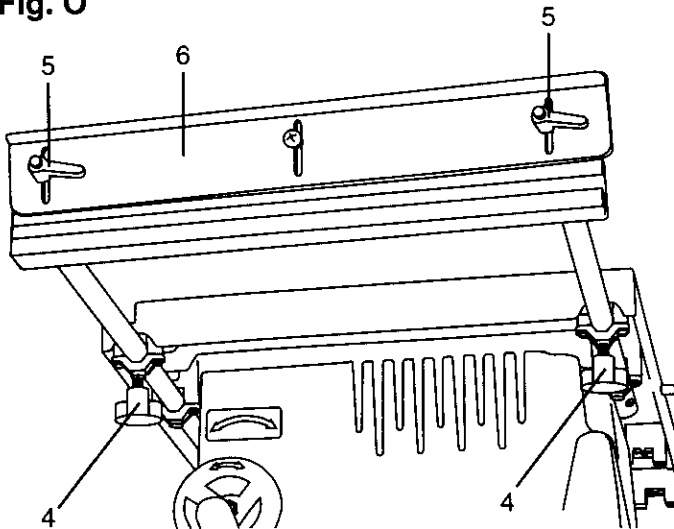

MITER GAUGE ADJUSTMENT (FIG. P)

1. Make sure that the miter gauge will slide freely through both table grooves.
2. Loosen the lock knob (1). Set the pointer (2) to the 90° mark on the scale.
3. Make a 90° cut in a piece of scrap wood. Check cut piece to see if it was cut at 90°. If it is not, continue to adjust the miter gauge body (3) until the wood piece is cut at 90°. Refer to OPERATION section for cutting instructions.

Fig. P

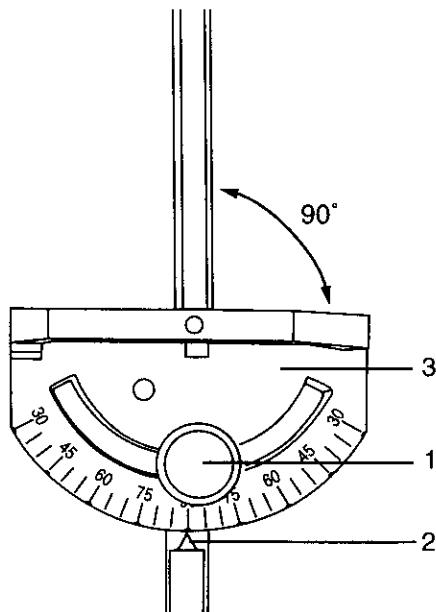

RIP FENCE ADJUSTMENT (FIG. Q)

▲ WARNING

To avoid injury from an accidental start, make sure the switch is in the OFF position and the plug is not connected to the power source outlet.

1. The fence (1) is moved by lifting up on the handle (2) and sliding the fence to the desired location. Pushing down on the handle locks the fence in position.
2. Position the fence on the right side of the table, and along one edge of the miter gauge grooves.
3. Lock the fence handle. The fence should be parallel with the miter gauge groove.
4. If adjustment is needed to make the fence parallel to the groove, do the following:
 - Loosen the two screws (3) and lift up on the handle (2).
 - Hold the fence bracket (4) firmly against the front of the saw table. Move the far end of the fence until it is parallel with the miter gauge groove.
 - Tighten both screws and push the handle to lock.
5. If fence is loose when the handle is in the locked (downward) position, do the following:
 - Move the handle (2) upward and turn the adjusting screw (5) clockwise until the rear clamp is snug. Do not turn the adjusting screw more than 1/4 turn at a time.
 - Over-tightening the adjusting screw will cause the fence to come out of alignment.

Fig. Q

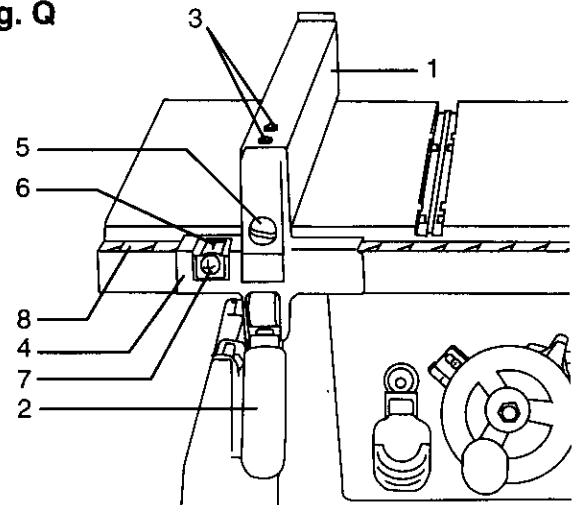

RIP FENCE INDICATOR ADJUSTMENT (FIG. Q)

1. The rip fence indicator (6) points to the measurement scale (8). The scale shows the distance from the side of the fence to the nearest side of the blade.
2. Measure the actual distance with a rule. If there is a difference between the measurement and the indicator, adjust the indicator (6).
3. Loosen the screw (7) and slide the indicator to the correct measurement on the scale. Tighten screw and remeasure with the rule.

▲ WARNING

To avoid injury from an accidental start, make sure the switch is in the OFF position and the plug is not connected to the power source outlet.

ADJUSTING THE 90° AND 45° POSITIVE STOPS (FIG. R, S)

Your saw has positive stops that will quickly position the saw blade at 90° or 45° to the table. These stops were set at the factory. Make adjustments only if necessary.

90° Stop

1. Disconnect the saw from the power source.
2. Turn the blade elevation handwheel and raise the blade to the maximum elevation.
3. Loosen the blade bevel lock knob and move the blade to the maximum vertical position. Tighten the lock knob.
4. Place a combination square on the table and against the blade (1) to determine if the blade is 90° to the table. (FIG. R)
5. If the blade is not 90° to the table, loosen the two set screws (4), located in the bottom of the table saw, (FIG. S) with the 3mm hex key, and back off the collar (5).
6. Loosen the bevel lock knob. Turn the blade tilting handwheel to move the blade until it is 90° to the table.
7. Adjust the collar (5) so it contacts the bracket (3) when the blade is 90° to the table. Tighten the two set screws (4).

Fig. R

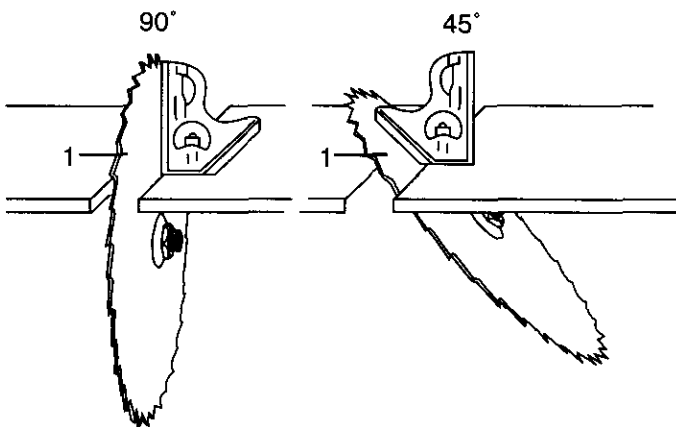

45° Stop

1. With the blade in the upright 90° position, loosen the bevel lock knob. Turn the blade tilting handwheel and move the blade to the 45° position as far as it will go.
2. Place the combination square on the table as shown in (FIG. R) to check if the blade is 45° to the table.
3. If the blade is not 45° to the table, loosen the two set screws (4) located under the table saw (FIG. S) with a 3 mm hex key, and back off the collar (5).

4. Loosen the bevel lock knob; turn the tilting handwheel to move the blade until it is 45° to the table.
5. Adjust the collar (5) so it contacts the bracket (3) when the blade is 45°. Tighten set screws (4).

Fig. S

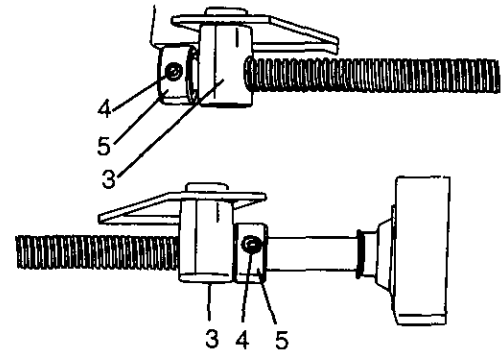

BLADE TILT POINTER

1. When the blade is positioned at 90°, adjust the blade tilt pointer to read 0° on the scale.
2. Loosen the holding screw, position the pointer over 0° and tighten the screw.

NOTE: Make a trial cut on scrap wood prior to making critical cuts. Measure for exactness.

BLADE PARALLEL TO MITER GAUGE GROOVE (FIG. T, U)

This adjustment was made at the factory, but it should be rechecked and adjusted if necessary.

▲ WARNING

To prevent personal injury:

- Always disconnect plug from the power source when making any adjustments.
- This adjustment must be correct or kickback could result and accurate cuts cannot be made.

Initial adjustment (FIG. T)

1. Remove the yellow switch key and unplug the saw.
2. Move the blade guard out of the way.
3. Raise the blade to the highest position and set at the 0° angle (90° straight up).
4. Select and mark, with a felt tip marker, a blade tooth having a "right set".
5. Place the combination square base (1) into the right side miter gauge groove (2). (FIG. T)
6. Adjust the rule so it touches the front marked tooth and lock the ruler so it holds its position in the square assembly.
7. Rotate the blade bringing the marked tooth to the rear and about 1/2 inch above the table.

8. Carefully slide the combination square to the rear until the ruler touches the marked tooth.
9. If the ruler touches the marked tooth at the front and rear positions, no adjustment is needed at this time. If not, perform adjustment procedure described in next section.

Fig. T

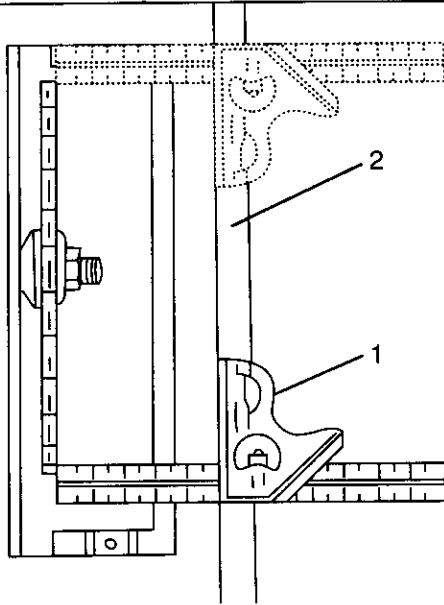

Additional blade adjustments (FIG. U)

1. If the front and rear measurements are not the same, remove the combination square and loosen the four adjusting screws (1) on the top of the table about a half turn.
2. With a folded piece of cardboard covering the blade to protect your hands, move the blade carefully to the left or right as much as needed to align the blade correctly.
3. Tighten the four screws (1) and remeasure, as described in steps 4 to 9 in the prior section.
4. If sufficient adjustment cannot be made by the four adjusting screws (1), then also loosen the two adjusting screws (2). Loosen these screws only if necessary.
5. Recheck blade clearance making sure that the blade does not hit the table insert or other parts when at the 90° and 45° settings.
6. Tighten all screws.

Fig. U

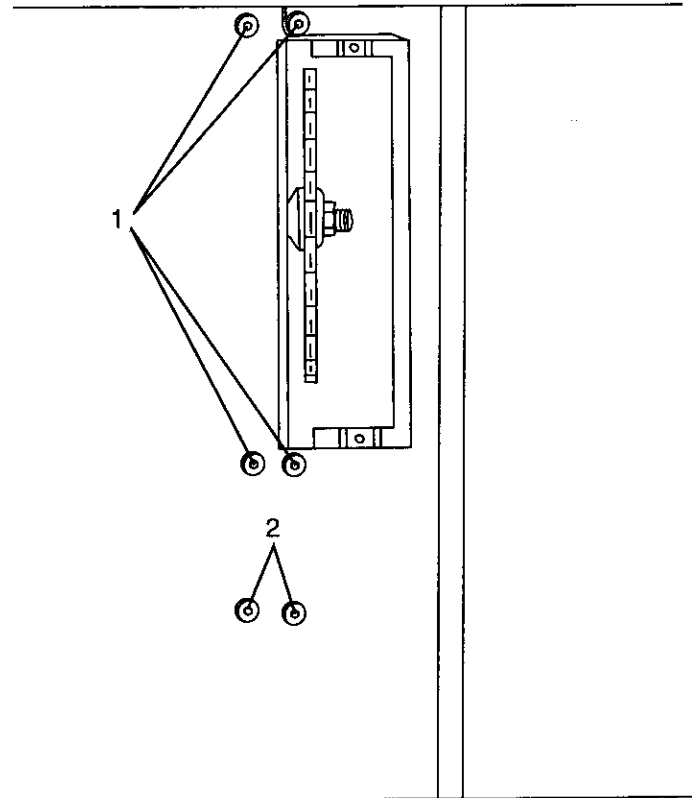

OPERATION

BASIC SAW OPERATIONS

RAISING THE BLADE (FIG. V)

To raise or lower the blade, turn the blade elevation handwheel (1) to the desired blade height, and then tighten lock handle (2) to maintain the desired blade angle.

Fig. V

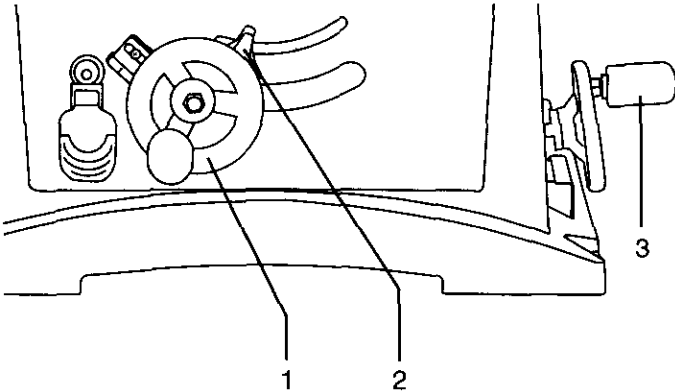

TILTING THE BLADE (FIG. V)

To tilt the saw blade for bevel cutting, loosen the lock handle (2) and turn the tilting handwheel (3). Tighten the lock handle (2) to secure.

ON / OFF SWITCH (FIG. W)

The ON / OFF switch has a removable key. With the key removed from the switch, unauthorized and hazardous use by children and others is minimized.

1. To turn the saw ON, insert key (1) into the slot in the switch (2). Move the switch upward to the ON position.
2. To turn the saw OFF, move the switch downward.
3. To lock the switch in the OFF position, grasp the sides (or yellow part) of the switch toggle (1), and pull it out.
4. With the switch key removed, the switch will not operate.
5. If the switch key is removed while the saw is running, it can be turned OFF but cannot be restarted without inserting the switch key (1).

Fig. W

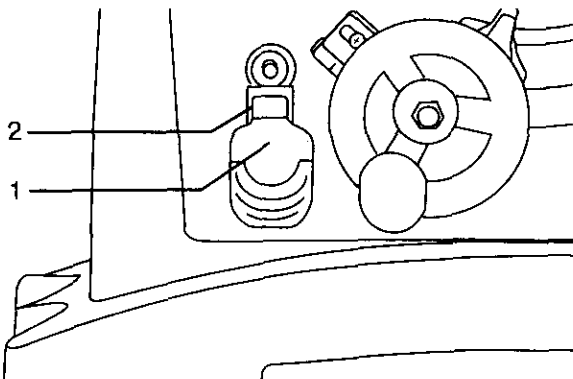

OVERLOAD PROTECTION (FIG. W)

This saw has a reset overload relay button (3) that will restart the motor after it shuts off due to overloading or low voltage. If the motor stops during operation, turn the ON /OFF switch to the OFF position. Unplug the saw from its power source. Wait about five minutes for the motor to cool down. Push in on the reset button (3) and turn the switch to the ON position.

▲ WARNING

To avoid injury, the ON/OFF switch should be in the OFF position and the plug removed from the power source while the motor cool down takes place, to prevent accidental starting when the reset button is pushed. Overheating may be caused by misaligned parts or dull blade. Inspect your saw for proper setup before using it again.

USING THE TABLE EXTENSION (FIG. X)

1. Remove the stop screws from the ends of the tubes.
2. Slide the ends of the tubes through both support brackets on the side your workpiece will be needing support, and replace the two stop screws.
3. Rotate the front tube to display the scale as an extension of the table top scale.
4. Slide the extension out until the correct measurement is displayed on the tube scale.
5. Loosen the fence handles, and raise or lower the fence as needed.
6. Tighten all extension support handles and knobs.

Fig. X

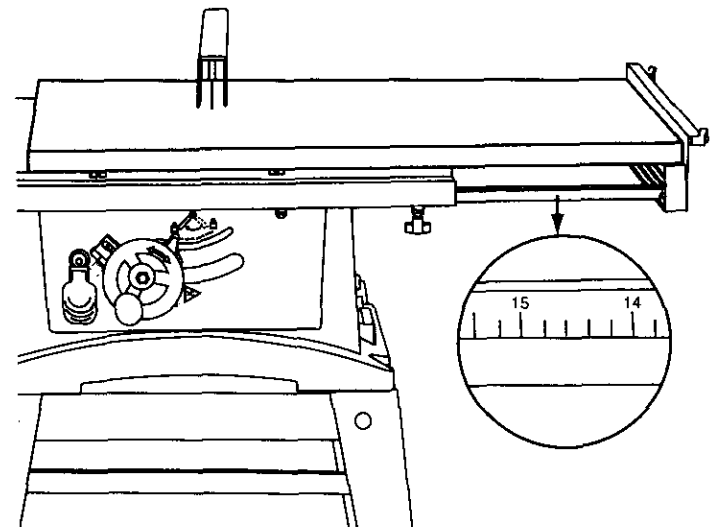

CUTTING OPERATIONS

There are two basic types of cuts: ripping and crosscutting. Ripping is cutting along the length and the grain of the workpiece. Crosscutting is cutting either across the width or across the grain of the workpiece. Neither ripping nor crosscutting may be done safely freehand. Ripping requires the use of the rip fence, and crosscutting requires the miter gauge.

▲ WARNING

Before you use the saw each and every time, check the following:

1. Blade is tight on the arbor.
2. Bevel angle lock knob is tight.
3. If ripping, fence knob is tight and fence is parallel to the miter gauge grooves.
4. Blade guard is in place and working properly.
5. You are wearing safety glasses.

The failure to adhere to these common safety rules, and those printed in the front of this manual, can greatly increase the likelihood of injury.

RIPPING (FIG. Y, Z)

▲ WARNING

To prevent serious injury:

- Do not allow familiarity gained from the frequent use of your table saw to cause careless mistakes. Remember that even a careless fraction of a second is enough to cause a severe injury.
 - Keep both hands away from the blade and path of the blade.
 - The workpiece must have a straight edge against the fence and must not be warped, twisted, or bowed.
1. Remove the miter gauge. Secure the rip fence to the table.
 2. Raise the blade so it is about 1/8" higher than the top of the workpiece.
 3. Place the workpiece flat on the table and against the fence. Keep the workpiece about 1" away from the blade.
 4. Turn the saw ON and wait for the blade to come up to speed.
 5. Slowly feed the workpiece into the blade by pushing forward only on the workpiece section (1) that will pass between the blade and the fence. (FIG. Y)

▲ WARNING

AVOID KICKBACK by pushing forward only on that section of the workpiece that will pass between the blade and the fence.

Fig. Y

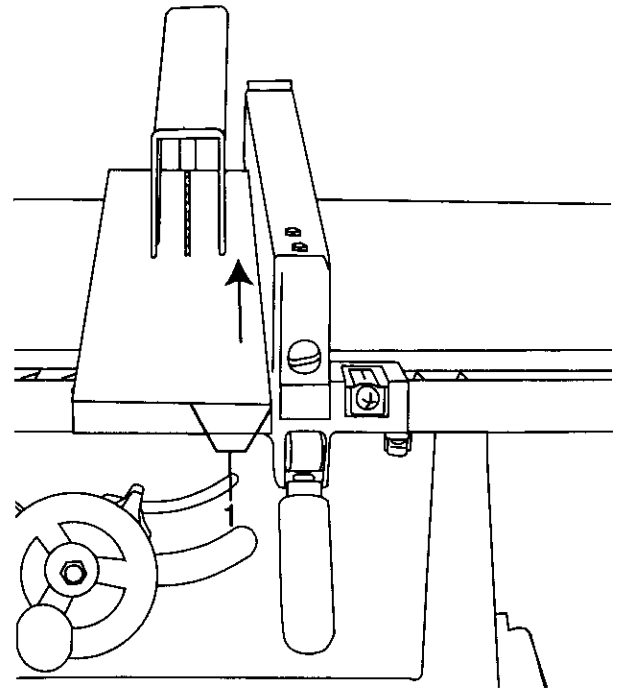

6. Keep your thumbs off the table top. When both of your thumbs touch the front edge of the table (2), finish the cut with a push stick. Make a push stick using the pattern on page 33.
7. The push stick (3) should always be used when the ripped workpiece is 2" or narrower (1). (FIG. Y)
8. Continue pushing the workpiece with the push stick (3) until it passes the blade guard and clears the rear of the table.
9. Never pull the workpiece back when the blade is turning. Turn the switch OFF. When the blade completely stops raise the anti-kickback pawls on each side of the splitter and slide the workpiece out.

Fig. Z

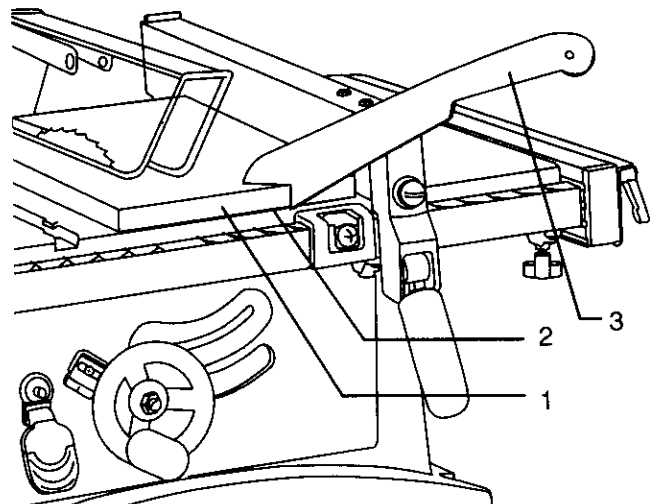

BEVEL RIPPING

This cut is the same as ripping except the blade bevel angle is set to an angle other than 0°.

▲ WARNING

Cut only with the workpiece and the fence on the right side of the blade.

RIPPING SMALL PIECES

▲ WARNING

Avoid injury from blade contact. Never make through-saw cuts narrower than 1/2" wide.

1. It is unsafe to rip small pieces. Instead, rip a larger piece to obtain the size of the desired piece.
2. When a small width is to be ripped and your hand cannot be safely put between the blade and the rip fence, use one or more push sticks to move the workpiece.

CROSSCUTTING (FIG. AA)

▲ WARNING

To prevent serious injury:

- Do not allow familiarity gained from the frequent use of your table saw to cause careless mistakes. Remember that even a careless fraction of a second is enough to cause a severe injury.
 - Keep both hands away from the blade and path of the blade.
1. Remove the rip fence and place the miter gauge in the left side groove.
 2. Adjust the blade height so it is 1/8" higher than the top of the workpiece.
 3. Hold the workpiece firmly against the miter gauge with the blade path in line with the desired cut location. Move the workpiece to one inch distance from the blade.
 4. Start the saw and wait for the blade (1) to come up to full speed.
 5. Keep the workpiece (2) against the face of the miter gauge (3) and flat against the table. Then slowly push the workpiece through the blade (**FIG. Z**).
 6. Do not try to pull the workpiece back with the blade turning. Turn the switch OFF, and carefully slide the workpiece out when the blade is completely stopped.

Fig. AA

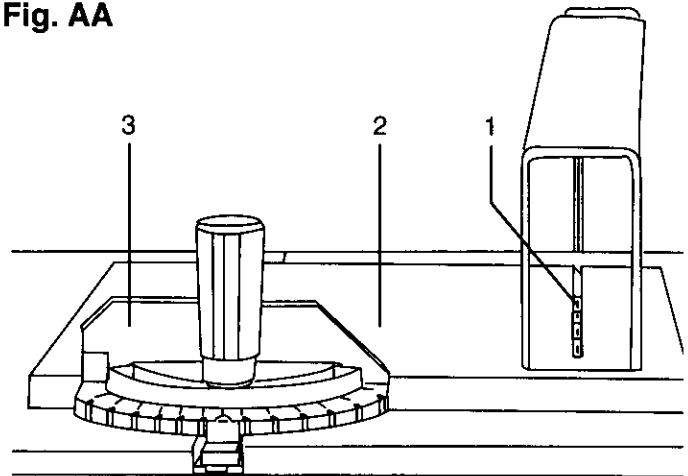

BEVEL CROSSCUTTING (FIG. BB)

This cutting operation is the same as crosscutting except the blade is at bevel angle other than 0°.

1. Adjust the blade (1) to the desired angle, and tighten the blade bevel lock knob.
2. Always work to the left side of the blade. The miter gauge (3) must be in the left side groove (2). It cannot be used in the right side groove unless the miter angle is very sharp, as it will interfere with the blade guard.

Fig. BB

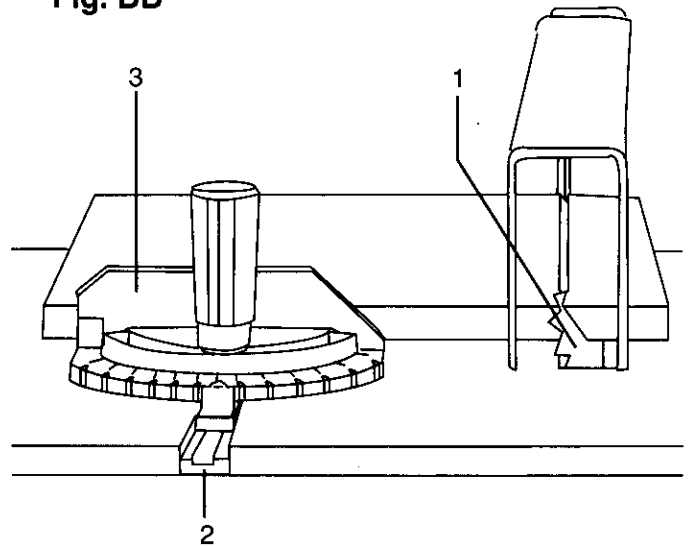

COMPOUND MITER CROSSCUTTING (FIG. CC)

This sawing operation combines a miter angle with a bevel angle.

1. Set the miter gauge (3) to the desired angle. Use only the left side groove (2).
2. Set the blade (1) bevel to the desired angle.
3. Carefully push the miter gauge to begin the cutting operation.

Fig. CC

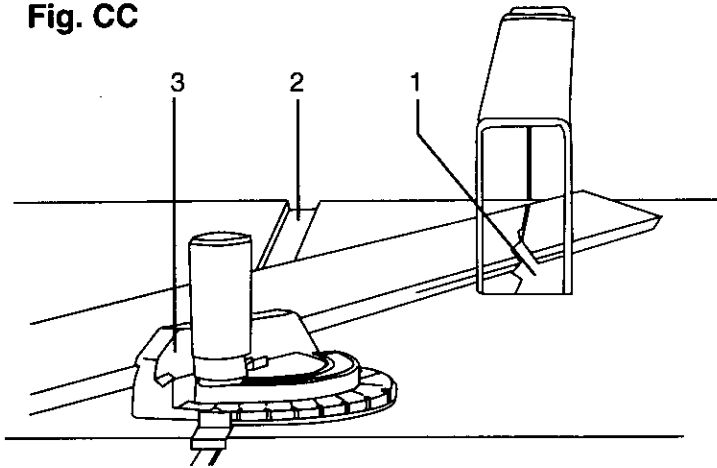

MITERING (FIG. DD)

This sawing operation is the same as crosscutting except the miter gauge is locked at an angle other than 90°.

1. Hold the workpiece (2) firmly against the miter gauge (3).
2. Feed the workpiece slowly into the blade (1) to prevent the workpiece from moving.

Fig. DD

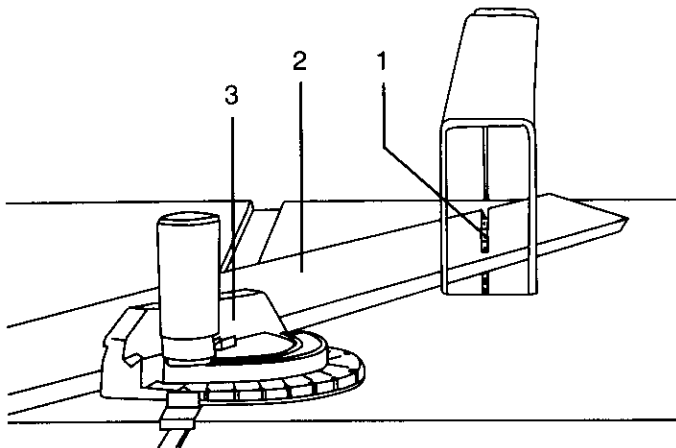

USING WOOD FACING ON THE RIP FENCE (FIG. EE)

When performing some special cutting operations, add a wood facing (1) to either side of the rip fence (2):

1. Use a smooth straight 3/4" thick wood board (1) that is as long as the rip fence.
2. Attach the wood facing to the fence with wood screws (3) through the holes in the fence. A wood fence should be used when ripping material such as thin paneling to prevent the material from catching between the bottom of the fence and the table.

Fig. EE

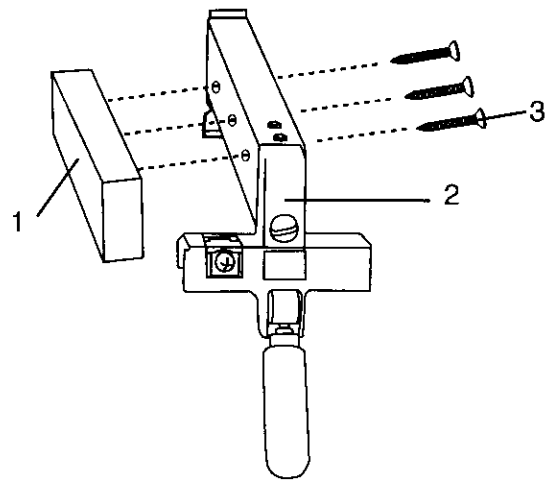

DADO CUTS (FIG. FF)

1. The dado table insert is included with this saw. Remove the saw blade, the blade guard, and the table insert. Install the dado and dado table insert.
2. Instructions for operating the dado are packed with the separately purchased dado set.
3. The arbor (1) on this saw restricts the maximum width of the cut to 1/2".
4. It is not necessary to install the outside flange (2) before screwing on the arbor nut (3). Make sure that the arbor nut is tight, and that at least one thread of the arbor sticks out past the nut.
5. Use only the 6" dado set and keep the width 1/2" or less. It will be necessary to remove the blade guard and splitter when using dado. Use caution when dado is operating.
6. Use only the correct number of round outside blades and inside chippers as shown in the dado set's instruction manual. Blade or chipper must not exceed 1/2".
7. Check saw to ensure that the dado will not strike the housing, insert, or motor when in operation.

▲ WARNING

For your own safety, always replace the blade, blade guard assembly, and blade insert when you are finished with the dado operation.

Fig. FF

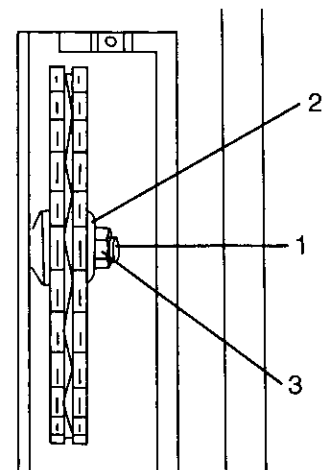

MAINTENANCE

MAINTAINING YOUR TABLE SAW

GENERAL MAINTENANCE

⚠ WARNING

For your own safety, turn the switch OFF and remove the switch key. Remove the plug from the power source outlet before maintaining or lubricating your saw.

1. Clean out all sawdust that has accumulated inside the saw cabinet and the motor.
2. Polish the saw table with an automotive wax to keep it clean and to make it easier to slide the workpiece.
3. Clean cutting blades with pitch and gum remover.
4. A worn, cut, or damaged power cord should be replaced immediately.

⚠ WARNING

All electrical or mechanical repairs should be attempted only by a trained repair technician. Contact the nearest Sears Service Center for service. Use only identical replacement parts. Any other parts may create a hazard.

5. Use liquid dish washing detergent and water to clean all plastic parts.

NOTE: Certain cleaning chemicals can damage plastic parts.

6. Avoid use of the following cleaning chemicals or solvents: gasoline, carbon tetrachloride, chlorinated solvents, ammonia and household detergents containing ammonia.

BLADE RAISING AND TILTING MECHANISM (FIG. GG)

After each five hours of operation, the blade raising mechanism and tilting mechanism should be checked for looseness, binding, or other abnormalities. With the saw disconnected from the power source, turn the saw upside down and alternately pull upward and downward on the motor unit. Observe any movement of the motor mounting mechanism. Looseness or play in the blade raising screw (1) should be adjusted as follows:

1. Using a wrench, loosen nut (2).
2. Adjust nut (3) until it is finger-tight against the bracket (4), then back off the nut (3) 1/6 turn.
3. Tighten nut (2) with the wrench, while holding nut (3) in place. Maximum allowable play of screw rod (1) is 4 mm.

Fig. GG

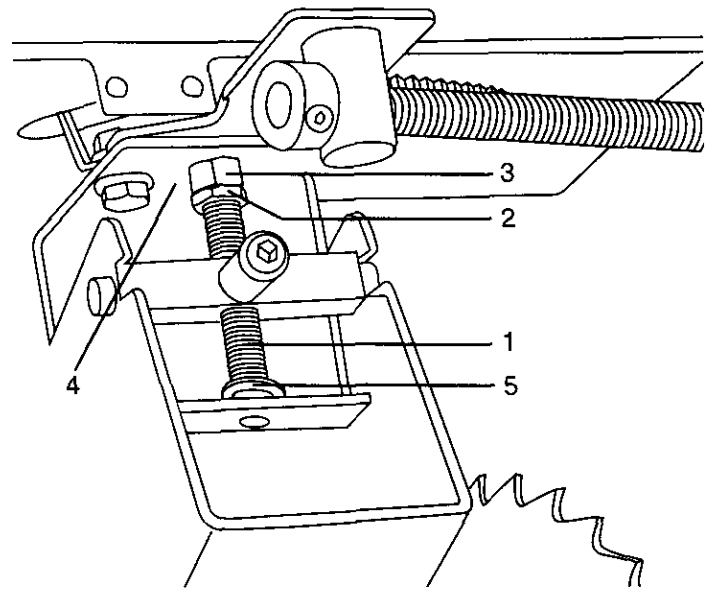

Place a small amount of dry lubricant such as graphite or silicon on screw rod (1) at thrust washer (5). Do not oil threads of screw rods (1). Screw rod (1) must be kept clean and free of sawdust, gum, pitch, and other contaminants for smooth operation.

If excessive looseness is observed in any other part of the blade raising mechanism or tilting mechanism, take the complete unit to a Sears Service Center.

LUBRICATION

All motor bearings are permanently lubricated at the factory and require no additional lubrication.

On all mechanical parts of your table saw where a pivot or threaded rod are present, lubricate using graphite or silicone. These dry lubricants will not hold sawdust as would oil or grease.

TROUBLESHOOTING

TROUBLESHOOTING GUIDE

▲ WARNING

To avoid injury from an accidental start, turn the switch OFF and always remove the plug from the power source before making any adjustments.

- Consult your local Sears Service Center if for any reason the motor will not run.

SYMPTOM	POSSIBLE CAUSES	CORRECTIVE ACTION
Saw will not start.	<ol style="list-style-type: none"> 1. Saw not plugged in. 2. Fuse blown or circuit breaker tripped. 3. Cord damaged. 	<ol style="list-style-type: none"> 1. Plug in saw. 2. Replace fuse or reset circuit breaker. 3. Have cord replaced by a Sears Service Center.
Does not make accurate 45° and 90° rip cuts.	<ol style="list-style-type: none"> 1. Positive stop not adjusted correctly. 2. Blade tilt pointer not set accurately. 	<ol style="list-style-type: none"> 1. Check blade with square and adjust positive stop. 2. Check blade with square and adjust pointer to zero.
Material pinches blade when ripping.	<ol style="list-style-type: none"> 1. Rip fence not aligned with blade. 2. Warped wood, edge against fence is not straight. 	<ol style="list-style-type: none"> 1. Check and adjust rip fence. 2. Select another piece of wood.
Material binds on splitter.	<ol style="list-style-type: none"> 1. Splitter not aligned correctly with blade. 	<ol style="list-style-type: none"> 1. Check and align splitter with blade.
Saw makes unsatisfactory cuts.	<ol style="list-style-type: none"> 1. Dull blade. 2. Blade mounted backwards. 3. Gum or pitch on blade. 4. Incorrect blade for work being done. 5. Gum or pitch on table causing erratic feed. 	<ol style="list-style-type: none"> 1. Replace blade. 2. Turn blade around. 3. Remove blade and clean with turpentine and coarse steel wool. 4. Change the blade. 5. Clean table with turpentine and steel wool.
Material kicked back from blade.	<ol style="list-style-type: none"> 1. Rip fence out of alignment. 2. Splitter not aligned with blade. 3. Feeding stock without rip fence. 4. Splitter not in place. 5. Dull blade. 6. The operator letting go of material before it is past saw blade. 7. Miter angle lock knob is not tight. 	<ol style="list-style-type: none"> 1. Align rip fence with miter gauge slot. 2. Align splitter with blade. 3. Install and use rip fence. 4. Install and use splitter (with guard). 5. Replace blade. 6. Push material all the way past saw blade before releasing work. 7. Tighten knob.
Blade does not raise or tilt freely.	<ol style="list-style-type: none"> 1. Sawdust and dirt in raising and tilting mechanisms. 	<ol style="list-style-type: none"> 1. Brush or blow out loose dust and dirt.
Blade does not come up to speed.	<ol style="list-style-type: none"> 1. Extension cord too light or too long. 2. Low house voltage. 	<ol style="list-style-type: none"> 1. Replace with adequate size cord. 2. Contact your electric company.
Machine vibrates excessively.	<ol style="list-style-type: none"> 1. Saw not mounted securely to workbench. 2. Bench on uneven floor. 3. Damaged saw blade. 	<ol style="list-style-type: none"> 1. Tighten all mounting hardware. 2. Reposition on flat level surface. Fasten to floor if necessary. 3. Replace blade.
Does not make accurate 45° and 90° cross cuts.	<ol style="list-style-type: none"> 1. Miter gauge out of adjustment. 	<ol style="list-style-type: none"> 1. Adjust miter gauge.

CRAFTSMAN 10" TABLE SAW

MODEL NO. 137.218250

WARNING

When servicing use only CRAFTSMAN replacement parts. Use of any other parts may create a HAZARD or cause product damage. Any attempt to repair or replace electrical parts on this Table Saw may create a HAZARD unless repair is done by a qualified service technician. Repair service is available at your nearest Sears Service Center.

PARTS LIST FOR SCHEMATIC A

Always order by PART NUMBER, not by key number

Key	Part No	Description	Size	Qty	Key	Part No	Description	Size	Qty
1	2615BBDD50	Hex head screw & washer	M6*1.0-40	1	40	2501MBDN06	Flat washer	ø 6*13-1	2
2	2501MBDN06	Flat washer	6*13-1	1	41	14212501	Spring		1
3	2705FBD106	Nut chuck	M6*1.0 T=6	1	42	14910208	Rear clamp		1
4	14994501	Warning label		1	43	14910104	Locking rod		1
5	2690MZD514	Rivet		2	44	14903101	Insert		1
6A	14912206 B1	Blade guard assembly		1	45	2621BBDA18	Pan head screw & washer	M5X0.8-12	2
6	14912206	Blade guard		1	46	14962201	Side cover		1
7	14994103	Caution label		1	47	14962301	Upper tube		1
8	2570DBN606	Self-locking ring		2	48	14960103	Extension wing		1
9	14912301	Arm		1	49	14962401	Scale		1
10	14912906	Splitter		1	50	2637BBDA70	Truss head round neck screw	M6X1.0-23	1
11	14912801	Bush		2	51	19600101A2	Locking handle assembly		2
12	14206901	Roll pin		1	52	14961601	Auxiliary fence		1
13	14913201	Bush		2	53	2704FBD106	Square nut	M6*1.0 T=5	3
14	14206601	Kick back pawl		2	54	2651PBDK17	Countersunk head tapping screw	M5*16-12	2
15	14208001	Kick back pawl		2	55	14961401	Side cover		1
16	2570DBN606	Self-locking ring		2	56	2668BBDA33	Pan head screw & washer	M5*16-12	2
17	2615BBDD22	Hex head screw & washer	M6*1.0-20	2	57	14961201	Guide holder		4
18	14205301	Spring		1	58	2602BBLA25	Hex socket head cap bolt	M5*0.8-16	8
19	2536MBE613	Spring pin	5-24	1	59	19500203	Clamp bolt		2
20	14914701	Damper		2	60	2675BNHA42	Pan head screw	M6X1.0-20	2
21	14915401	Caution label		1	61	14961001	Upper tube		1
22A	14910008A1	Parallel bracket assembly		1	62	2668BBDA23	Pan head screw	M5*0.8-8	2
22	14910008	Parallel bracket		1	63	14902909	Scale		1
23	2601BBDA40	Hex head bolt	M6*1.0-16	2	64	14902813	Table		1
24	2504MBC006	External tooth lock washer	ø 6	2	65	14915105	Warning stick label		1
25	14910505	Width body		1	66	2601BBDA47	Hex head bolt	M6*1.0-50	1
26	14212501	Compression spring		1	67	2504MBC006	External tooth lock washer	ø 6	1
27	14915701	Cap screw		1	68	2501NBDN16	Flat washer	1/4*3/4-1/16	1
28	15218801	Hex nut		1	69	14205001	Guard bracket		1
29	18622601	Pointer		1	70	2701FBD106	Hex. nut	M6*1.0 T=5	2
30	2641BBDA22	Round washer head screw	M5*0.8-6	1	71	14914901	Washer		1
31	14916901	Grip		1	72	2604BBLA42	Hex socket countersunk head screw	M6*1.0-25	6
32A	14911301A1	Bolt clamp assembly		1	73	2801ABRG01	Strain relief		1
32	14211203	Bolt clamp		1	74	2636BBDA49	Countersunk head screw	M6*1.0-50	4
33	2701FBD113	Hex. nut	M8*1.25,T=6.5	1	75	2668BDDA43	Pan head screw		1
34	14915604	Eccentric		1	76	2668BDDA44	Pan head screw		1
35	14911007	Link		1	180	2636BDB48	Countersunk	M6*1.0-55	1
36	14917202	Spring plate		1	181	280655545N	Lead wire ass'y		1
37	2660PBCK16	Pan head screw	M5X16-10	1	182	14994601	Warning label		1
38	2536MBE627	Spring pin		1					
39	2536MBE638	Spring pin	5-30	1					

CRAFTSMAN 10" TABLE SAW
SCHEMATIC A

MODEL NO. 137.218250

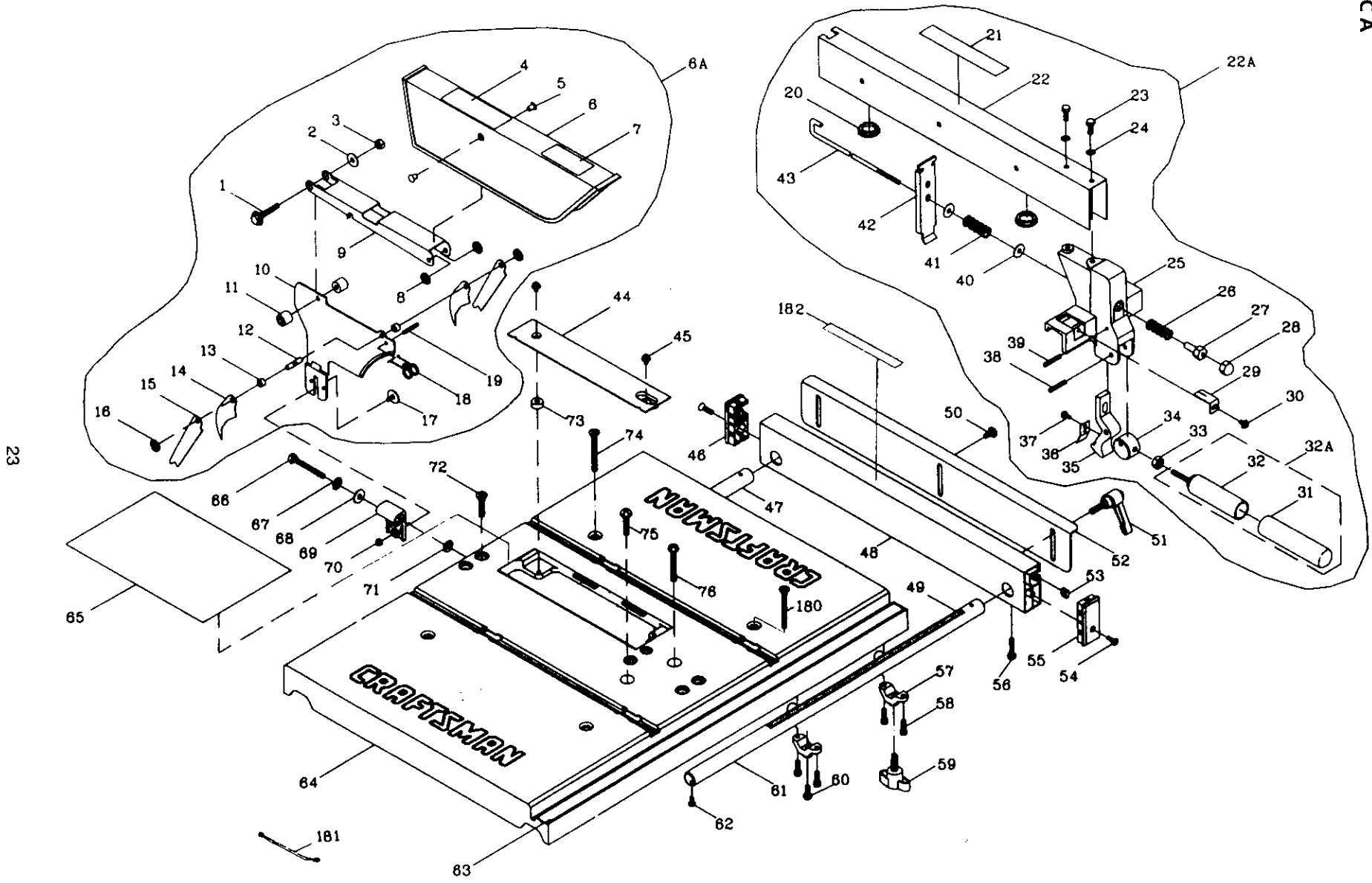

CRAFTSMAN 10" TABLE SAW

MODEL NO. 137.218250

PARTS LIST FOR SCHEMATIC B

Key	Part	Description	Size	Qty	Key	Part	Description	Size	Qty
77	14916901	Grip		1	111	18402702	Dust shield		4
78A	14911601A1	Bolt clamp assembly		1	112	2801DBHA04	Strain relief		2
78	14211201	Bolt clamp		1	113	14902302	Switch box		1
79	2501NBDN16	Flat washer	1/4*3/4-1/16	1	114	14900136	Body shell		1
80A	14911402A5	Mitre gauge assembly		1	115	14909401	Trade mark label		1
80	14911402	Mitre gauge		1	116	2668BZDA07	Pan head screw	M4*0.7-8	3
81	14608001	Pin		1	117	2504MZC004	External tooth lock washer	ø 4	3
82	14911802	Angle pointer		1	118	2853U55501	Circuit breaker switch		1
83	29835L5006	Steel ball		1	119	2661MBDE12	Truss head tapping screw	M4*16-10	6
84	14523301	Compression spring		1	120	2653MBDE11	Truss head tapping screw	M4*16-12	4
85	2603BBLA38	Hex socket set screw	M6*1.0-10	1	121A	2898D10G06	Rocker switch		1
86	14911707	Sheet bar		1	121	2851D55G06	Rocker switch element		1
87	2608BBLA32	Hex socket truss head screw	M5*0.8-10	2	122	28605BH101	Switch key		1
88	14937101	Wheel		1	123	14901704	Needle pointer		1
88A	14937101A2	Hand wheel assembly		1	124	2668BBDA32	Pan head screw	M5*0.8-10	1
89	2570BBN209	E-ring	E-9	2	125	2701FBD113	Hex nut	M8*1.25,T=6.5	1
90	2536MBE605	Spring pin	3-24	2	126	2501MBDN08	Flat washer	8X16-2.5	1
91	2536MBE629	Spring pin	3-14	1	127	14901503	Pointer bracket		1
92	14936001	Screw bar		1	128	14901103	Height regulating bolt		1
93	14936501	Parrie ring		2	129A	14900609A2	Hand wheel assembly		1
94	2603BBLA36	Hex socket set screw	M6*1.0-6	4	129	14900609	Wheel		1
95	14936701	Caution label		1	130	2703FMD108	Crown nut	M8*1.25 T=12.5	2
96	2668BBDA39	Pan head screw	M6*1.0-12	4	131	14909001	Grip		2
97	2501NBDN12	Flat washer	1/4*5/8-1/16	2	132	14900801	Bolt		2
98	14906107	Warning label		1	133	14900703	Clamp handle		2
99	2501NBDN16	Flat washer	1/4*3/4-1/16	4	134	2701FBD110	Hex nut	M10*1.5 T=8	2
100	2709FBDA02	Hexagon nut & flat washer		4	135	15100801	Lock knob		1
101	2707FBN107	U-type nut		6	136	2501NBDN16	Flat washer	1/4*3/4-1/16	1
102	14903104	Insert		1	137	14905804	Retaining clip		1
103	14014801	Wrench hex		1	183	14994701	Warning label		1
104	14904402	Wrench		1					
105	2138MBL704	Wrench hex		1					
106	2138MBL709	Wrench hex		1					
107A	2807BB06AFA1	Power cable assembly		1					
107	2807BB06AF	Power cable		1					
108	2801ABRF01	Strain relief		1					
109	13601201	Cord clamp		1					
110	2660MBCE14	Pan head tapping screw	M4*16-16	2					

CRAFTSMAN 10" TABLE SAW

MODEL NO. 137.218250

SCHEMATIC B

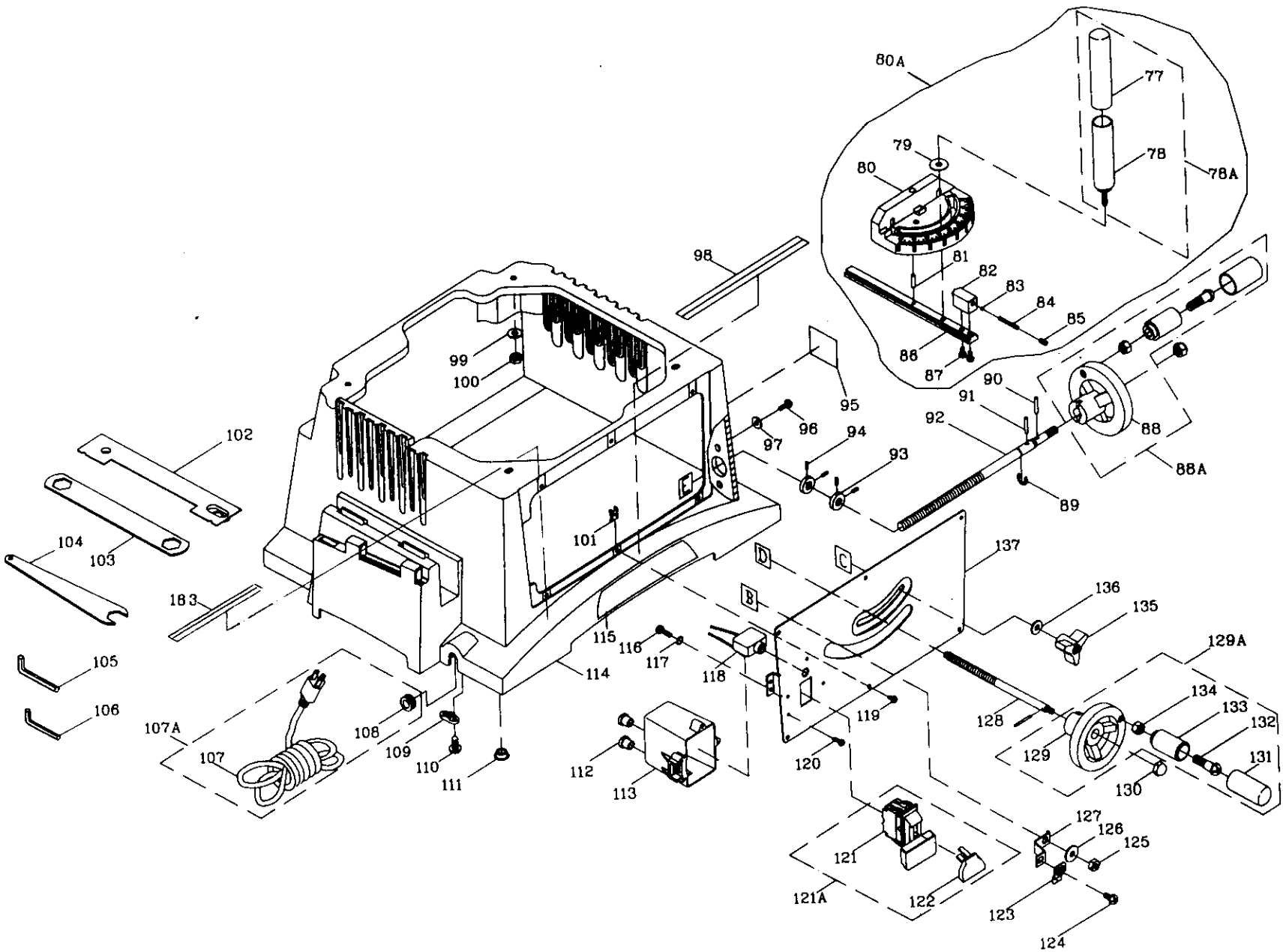

PARTS

CRAFTSMAN 10" TABLE SAW

MODEL NO. 137.218250

PARTS LIST FOR SCHEMATIC C

Key	Part No.	Description	Size	Qty	Key	Part No.	Description	Size	Qty
138	14930002	Set nut		1	158	14901302	Spring		1
139	14930102	Arbor collar		1	159	2603BBLA66	Hex. socket set screw	M10*1.5-12	1
140	14930203	Blade		1	160	2701FBD111	Hex. nut	M10*1.5 T=4	1
141	8387129942	Motor		1	161	2701FBD110	Hex. nut	M10*1.5 T=8	1
142	2620BBDC18	Pan head screw & washer	M5*0.8-12	1	162	2615BBDD25	Hex head screw & washer	M8*1.25-16	1
143	14936201	Bearing seat		1	163	2672BBDA40	Cap head square neck bolt	M6*1.0-16	2
144	14936301	Shaft		1	<hr/>				
145	14935904	Stiffener		1	164	2570BBN116	C-ring	A-16	1
146	2708FBD107	Serrated toothed hex. flange nut	M6*1.0 T=6	2	165	14935102	Supporting plate		1
147	14921307	Angle rod		1	166	14935001	Nut		1
148	14921403	Strap		6	167	2672BBDA44	Cap head square neck bolt	M6*1.0-35	1
149	2502NBC406	Spring washer	ø 1/4"	6	168	14922901	Spacer		1
150	2708FBD107	Serrated toothed hex flange nut	M6*1.0 T=6	6	169	2701FBD106	Hex nut	M6*1.0 T=5	1
<hr/>					170	2501NBDN09	Flat washer	1/4*3/4-7/64	1
151	14921001	Plunger housing		1	171	2502ABC417	Flat washer	ø 6	1
152	14921703	Bracket		1	172	2701FBD106	Hex nut	M6*1.0 T=5	1
153	2501NBDN03	Flat washer	3/16*3/8-0.022	1	173	2709FBDA02	Hex nut & flat washer	M6*1.0	1
154	2617BBLC11	Hex socket head cap screw	M5*0.8-20	1	174	14920003	Motor bracket		1
155	2501NNHN34	Flat washer	3/8*3/4-5/64	2	175	14920301	Spacer		1
156	14921802	Bracket		1	176	2701FBD105	Hex nut	M5*0.8 T=4	1
157	14901203	Saddle		1	177	2615BBDC25	Hex head screw and washer	M8*1.25-16	4
<hr/>					178	2672BBDB50	Cap head square neck bolt	M8*1.25-16	4
<hr/>					179	2536MBE621	Spring pin	8-90	1
<hr/>					*	137218250001	Owner's Manual		1
<hr/>					*	Not Shown			

CRAFTSMAN 10" TABLE SAW
SCHEMATIC C

MODEL NO. 137.218250

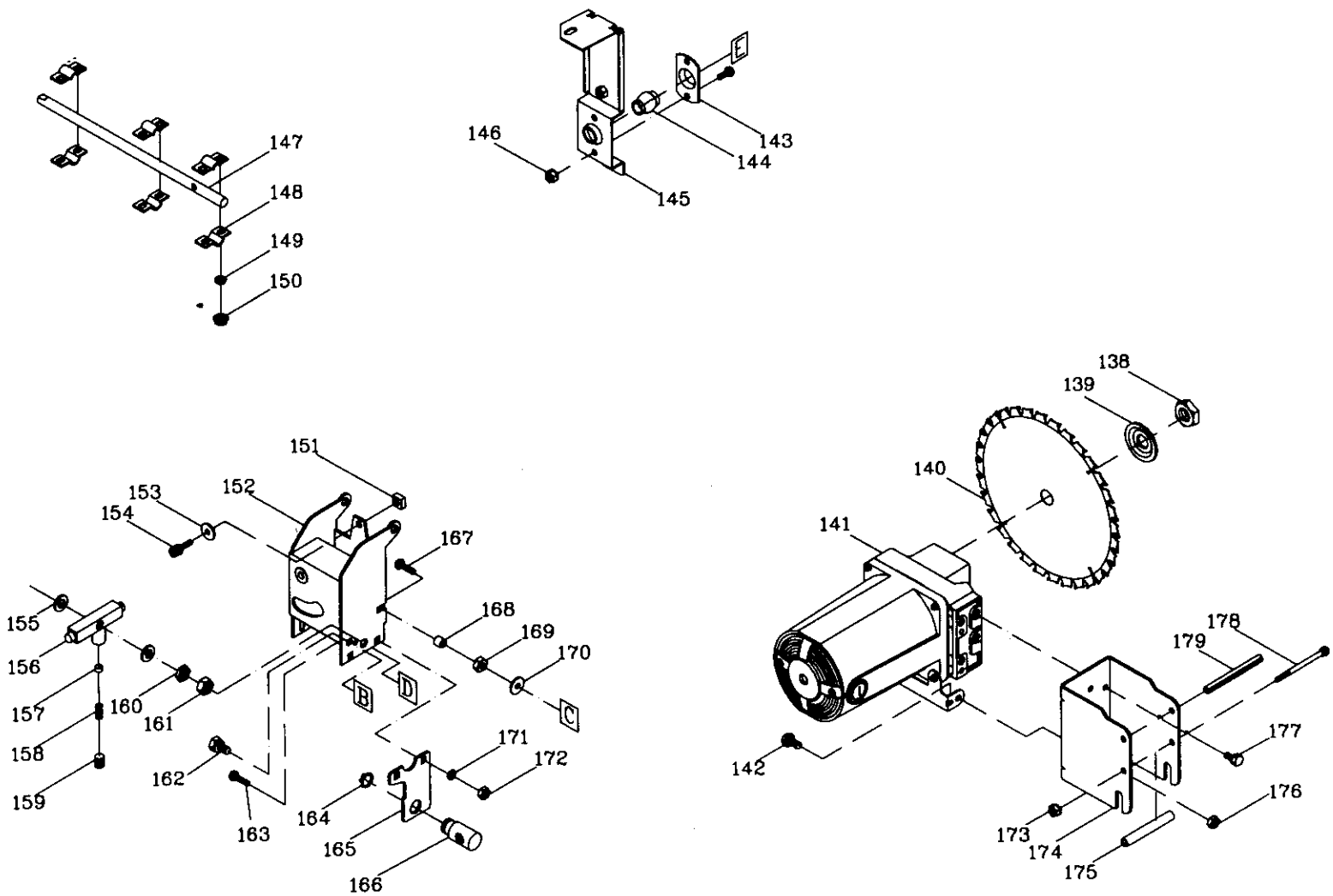

PARTS

CRAFTSMAN 10" TABLE SAW LEG STAND

MODEL NO. 137.218250

PARTS LIST FOR SCHEMATIC D

Key	Part No.	Description	Size	Qty
1	17050106	Leg		4
2	2672BBDA54	Cap head square neck bolt	M8x1.25-16	16
3	17050407	Bottom support bracket (long)	L=563	2
4	2601BBDA69	Hex head bolt	M10x1.5-20	4
5	14000304	Spacer (foot pad)		4
6	2501MBDN11	Flat washer	ø10x20-2	4
7	2701FBD109	Hex nut	M10x1.5 T=8	4
8	2708FBD112	Serrated toothed hexagon flange nut	M8x1.25 T=7.5	20
9	17050307	Upper support bracket (short)	L=413	2
10	2601BBDA57	Hex head bolt	M8x1.5-30	4
11	2501MBDN08	Flat washer	ø8x16-2.5	4
12	17050209	Upper support bracket (long)	L=491	2
13	17050505	Bottom support bracket (short)	L=475	2

SCHEMATIC D

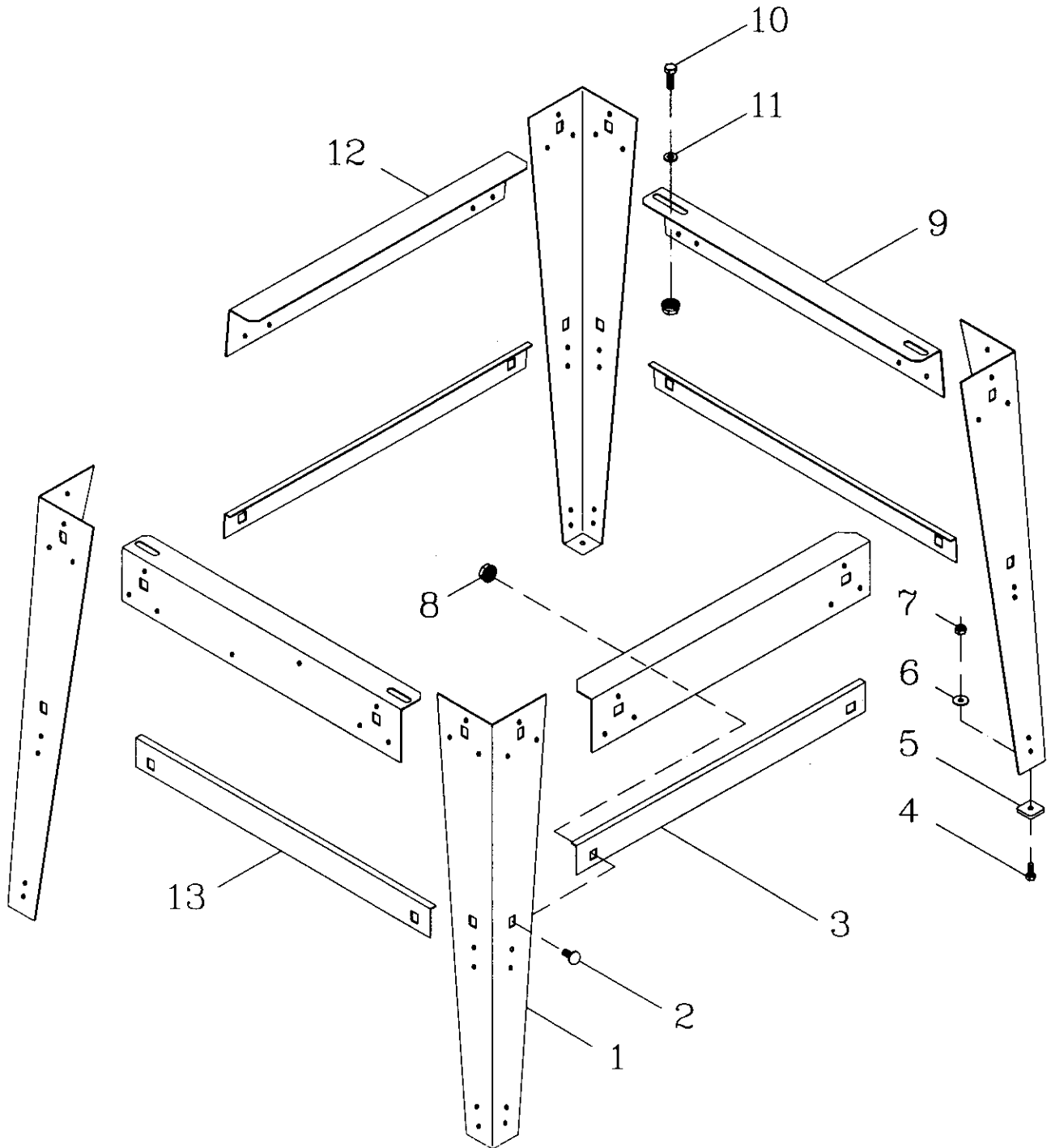

PARTS

MOTOR

PARTS LIST FOR SCHEMATIC E

MODEL NO. 137.218250

Key	Part No.	Description	Size	Qty
1	2620BBDB26	Pan head screw	M5X0.8-30	4
2	83871271	Support plate		1
3	2603BBLA23	Hex socket set screw	M5X0.8-8	2
4	87840021	Motor housing		1
5	83962491A1	Brush holder assembly		2ST
6	83990291A1	Brush assembly		2ST
7	83990301	Brush cover		2
8	87840081	Bearing bushing		1
9	83870111A2	Field assembly		1
10	2662MZDE41	Pan head tapping screw	M5X12-60	2
11	87840131	Baffle		1
12	87840122A2	Armature assembly		1
13	83871141	Motor nameplate		1
14	2801UBHA07	Strain relief bushing		1
15	83871161	Bracket		1
16	2001AH1010	Needle bearing		1
17	2570BBN117	C-ring		1
18	87840171	Helix gear		1
19	83871201	Collar		1
20	2001LU6204	Ball bearing	6204LLU	1
21	83870221	Bearing retainer		1
22	2504MZF004	External tooth lock washer	ø4	4
23	2636BZDA07	Countersunk head screw	M4x0.7-8	4
24	2571MNC252	Parallel key		1
25	83870253	Arbor shaft		1

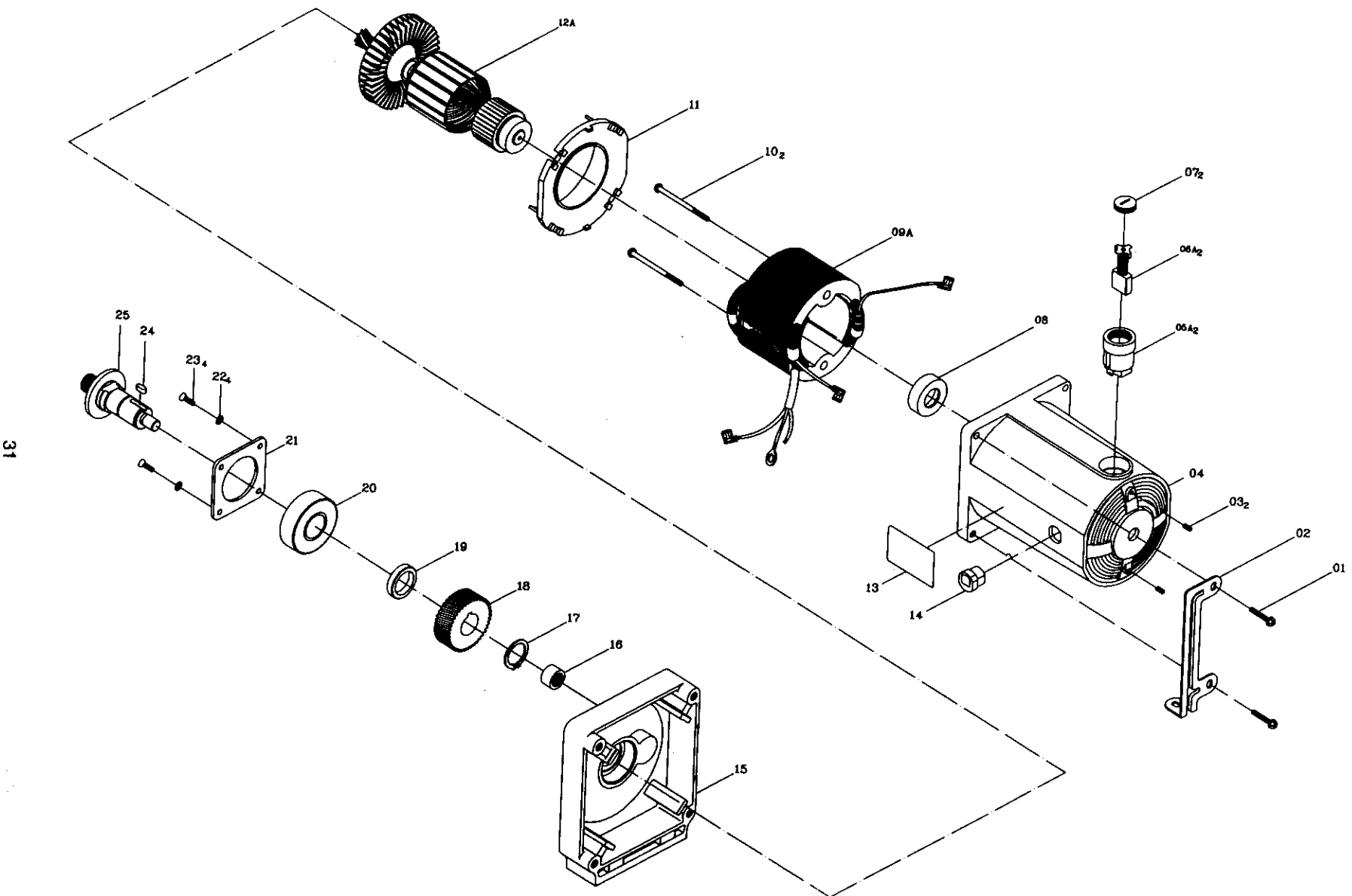

NOTES/NOTAS

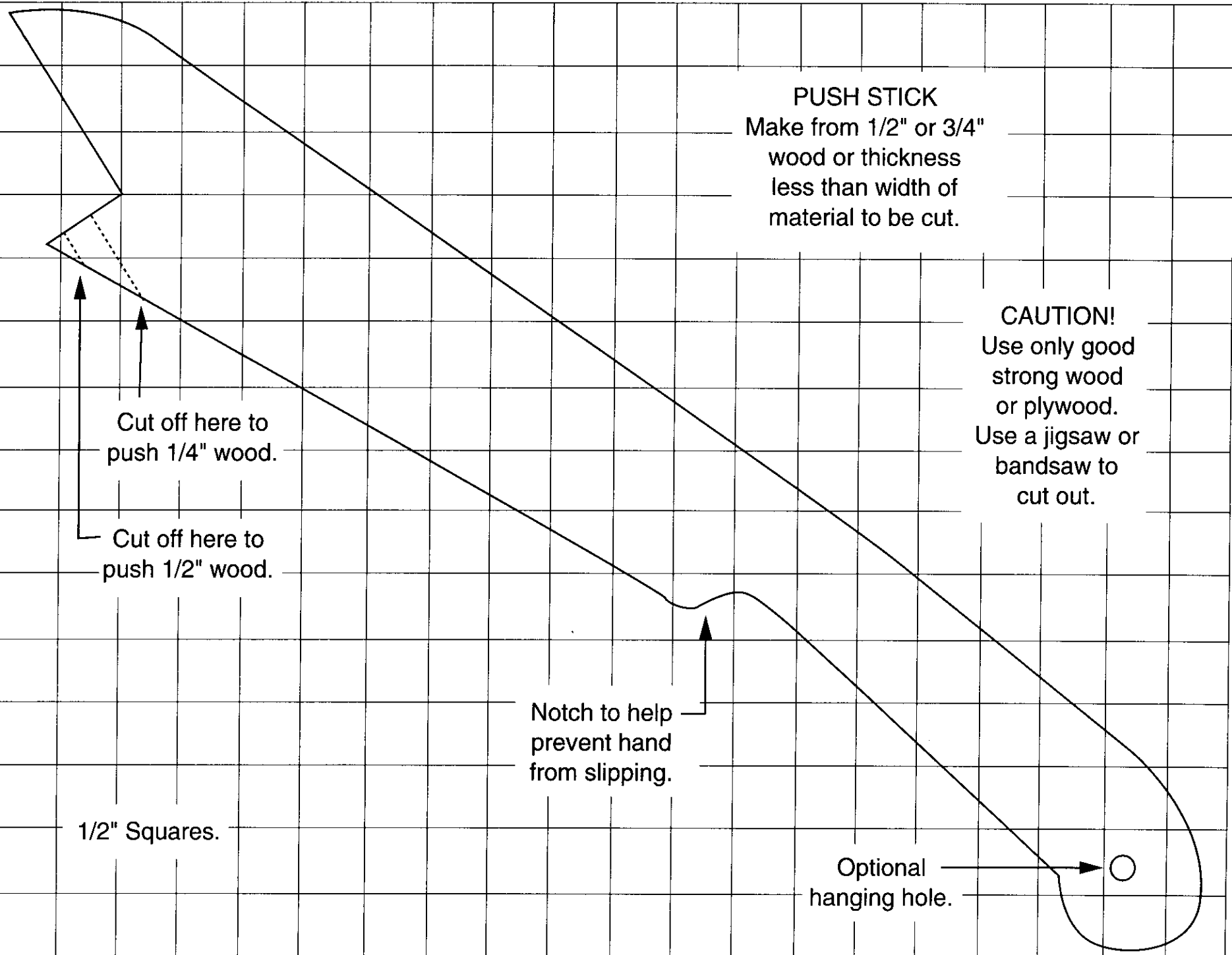

PUSH STICK
 Make from 1/2" or 3/4"
 wood or thickness
 less than width of
 material to be cut.

CAUTION!
 Use only good
 strong wood
 or plywood.
 Use a jigsaw or
 bandsaw to
 cut out.

Cut off here to
 push 1/4" wood.

Cut off here to
 push 1/2" wood.

Notch to help
 prevent hand
 from slipping.

1/2" Squares.

Optional
 hanging hole.

Get it fixed, at your home or ours!

For repair of major brand appliances in **your own home...**
no matter who made it, no matter who sold it!

1-800-4-MY-HOMESM Anytime, day or night
(1-800-469-4663)

www.sears.com

To bring in products such as vacuums, lawn equipment and electronics
for repair, call for the location of your nearest **Sears Parts & Repair Center.**

1-800-488-1222 Anytime, day or night

www.sears.com

For the replacement parts, accessories and owner's manuals
that you need to do-it-yourself, call **Sears PartsDirectSM!**

1-800-366-PART 6 a.m. – 11 p.m. CST,
(1-800-366-7278) 7 days a week

www.sears.com/partsdirect

To purchase or inquire about a Sears Service Agreement:

1-800-827-6655

7 a.m. – 5 p.m. CST, Mon. – Sat.

Para pedir servicio de reparación a domicilio,
y para ordenar piezas con entrega a domicilio:

1-888-SU-HOGARSM
(1-888-784-6427)

Au Canada pour service en français:

1-877-LE-FOYERSM
(1-877-533-6937)

SEARS
HomeCentral™