

# Hotpoint Service Offices

**SERVICE CALL:** If you have a problem with your appliance ring your local Service Office. **SPARES and ACCESSORIES:** To purchase spares and accessories send your Accessories Order Form to your Spares Centre. If the accessory or spare part you want is not on the form then contact your Spares Centre for prices and availability. Please address all correspondence to Hotpoint Spares Centre or Hotpoint Service Office as applicable.

Service Offices and Spares Centres are open between 8.30am-5.00pm Monday to Friday, except on public holidays. 8.30am-12.30pm on Saturdays.

## IRELAND

**Northern Ireland:**  
256 Ormeau Road, Belfast, BT7 2TZ.  
Tel: Belfast 647111.  
Fax: 3536 Aran Quay, Dublin 7.  
Tel: Dublin 725922.  
Tel: Dublin 725922.  
Spares and accessories may be ordered from either address.

## NORTH WEST

- **KENDAL:** 28 Highgate, LA9 4SX. Tel: Kendal 24463.
- **PRESTON:** 24/25 Cannon Street, PR1 3NR. Tel: Preston 24311.
- **ST. HELENS:** 40 Cowley Hill Lane, WA10 2AD. Tel: St. Helens 35152.
- **ELLSMERE PORT:**
  - 1 Durron Parade, L65 2ER. Tel: 051-866 2141.
  - **STOCKPORT:** 46/46a Station Road, Headingley, M20 9BZ. Tel: 061-432 0256.

## WALES

- **LLANDUDNO JUNCTION:** Conwy Road, L55 2JL. Tel: 0548 810206.
- **BIRKENHEAD:** 81/83a, Bridgend Industrial Estate, C79 3SL. Tel: Office Bridgend 64121. Centre Bridgend 64121.

## WEST MIDLANDS

- **STONE-ON-TRENT:** West Avenue, Nelson Estate, Kidsgrove, S17 1TN. Tel: Kidsgrove 774511.
- **ALDRIDGE:** Westgate, W59 8UX. Tel: Office Aldridge 743374. Centre Aldridge 743374.

## SOUTH MIDLANDS

- **DINGCOT:** 224 Broadway, OX11 8RS. Tel: Oxford 817711.  
Spares and accessories may be ordered from either Aldridge or Wembley Centres.

## SOUTH WEST

- **BRISTOL:** 3/5 Brislington Hill, Brislington, BS4 5BQ. Tel: Bristol 714471.
- **PLYMOUTH:** 69 Mulvey Plain, PL4 6JH. Tel: Plymouth 262631.
- **TOTTEN:** South Hampshire Industrial Park, Salisbury Road, SO4 3SA. Tel: Office Totton 861961. Centre Totton 861961.

In accordance with its policy of progressive product design, the Company reserves the right to alter specifications.

Hotpoint Ltd, Peterborough, PE2 9JB, England

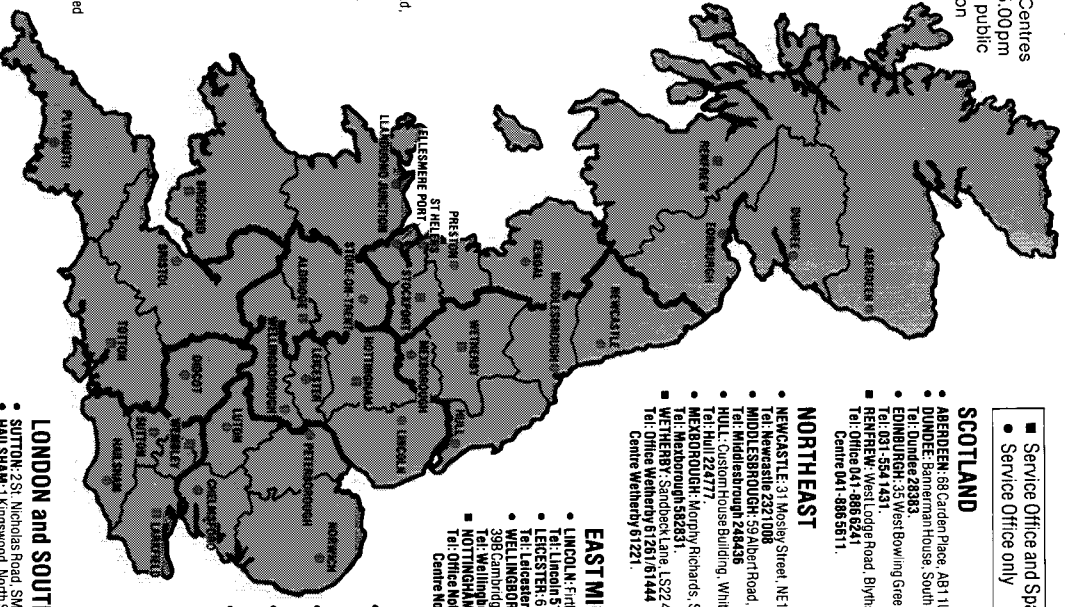

- Service Office and Spares Centre
- Service Office only

## SCOTLAND

- **ABERDEEN:** 88 Carden Place, AB9 1UL. Tel: Aberdeen 642283.
- **DUNDEE:** Parknair House, South Tay Street, DD1 1NR.
- **EDINBURGH:** 55 Bowing Green Street, Leith, EH6 5NX. Tel: 031-554 1431.
- **RENFREW:** West Lodge Road, Blythswood Estate, PA4 9EN. Tel: Office 041-866 6241. Centre 041-866 5611.

## NORTH EAST

- **NEWCASTLE:** 31 Mosley Street, NE1 1YF.
- **MIDLESBROUGH:** 35A Dorr Road, TS1 1NG.
- **LEEDS:** 246A3B.
- **HULL:** 10/20/277 Towns Building, Whitefriargate, HU1 2EU.
- **MEXBOROUGH:** Morphy Richards, Swinton Works, S64 8AU. Tel: Mexborough 82831.
- **WETHERBY:** Sandbeck Lane, LS22 4TW. Tel: Office Wetherby 61261/61444. Centre Wetherby 61221.

## EAST MIDLANDS

- **LINCOLN:** High Road, LN6 7BW. Tel: Lincoln 512300.
- **LEICESTER:** 65 Belgrave Gate, LE1 3HR. Tel: Leicester 514455.
- **WELLINGBOROUGH:** 398 Cambridge Street, NN8 1DW. Tel: Wellingborough 23889.
- **NOTTINGHAM:** Ashing Street, NG2 3JB. Tel: Office Nottingham 60397. Centre Nottingham 60397.

## EASTERN

- **NORHAMPTON:** 92/111, Giles Street, NR2 1LT. Tel: Norwich 620681.
- **PETERBOROUGH:** Celia Road, PE2 9JB. Tel: Peterborough 64741.
- **LUTON:** 5, Crawley Road, LU1 1HX. Tel: Luton 462211.
- **CHELMSFORD:** Industrial Building, St. Peter's Lane, CE1 1DE. Tel: Chelmsford 769331.
- Spares and accessories may be ordered from Notingham Spares and Accessories Centre, Peterborough, PE2 9JB. Tel: Peterborough 98989.

## LONDON and SOUTH EAST

- **SUTTON:** 2 St. Nicholas Road, SM1 1EH. Tel: 01-643 0921.
- **HALLSHAM:** 1 Kingswood, North Street, BN27 1DD.
- **WEMBLEY:** 68 East Lane, HA9 7PD. Tel: Hallsham 842733.
- **Office for London area 01-504 1250. Office for London area 01-504 1201.**
- **LARKHEDD:** 149, Oldfield Way, Highgate Estate, New Hythe Lane, ME20 8SW. Tel: Office Maidstone 76531. Centre Maidstone 76531.

# HOTPOINT HANDBOOK FRIDGE FREEZER

## MODEL 8350



# Hotpoint®

## Your new Hotpoint Fridge Freezer

Using your new fridge freezer is very simple. Nevertheless, for your own safety and to get the best results it is important that you read right through this handbook **before** using your fridge freezer for the first time. Do not load the freezer compartment immediately the fridge freezer is switched on, but wait until the correct storage temperature has been reached (see page 8).

### Electrical Requirements

We recommend that this appliance is connected to the mains supply via a suitable switched socket in a readily accessible position.

All Hotpoint appliances come complete with a fitted plug. The plug on your fridge freezer has a 13A fuse. If the plug does not fit your sockets, a new plug can be fitted. Cut off the old plug and throw it away, do not insert it into a socket elsewhere in the house as this could cause a shock hazard.

**WARNING: THIS APPLIANCE MUST BE EARTHED.**

### IMPORTANT: Fitting a Different Plug:

The wires in the mains lead are coloured in accordance with the following code:

- Green and Yellow – Earth
- Blue – Neutral
- Brown – Live

If you fit your own plug the colours of these wires may not correspond with the identifying marks on the plug terminals. This is what you have to do:

1. Connect the green and yellow (Earth) wire to the terminal in the plug marked 'E' or with the symbol  $\frac{\text{—}}{\text{—}}$ , or coloured green or green and yellow.
  2. Connect the blue (Neutral) wire to the terminal in the plug marked 'N' or coloured black.
  3. Connect the brown (Live) wire to the terminal marked 'L' or coloured red.
- With alternative plugs a 5A fuse must be fitted either in the plug or adaptor or in the main fuse box. In the event of replacing a fuse in the plug supplied, a 13A ASTA approved fuse to BS1362 must be fitted.

If the plug is the moulded on type the fuse cover must be refitted when changing the fuse. In the event of losing the fuse cover the plug must **not** be used until a replacement fuse cover has been obtained and fitted. A new fuse cover can be obtained from your nearest Hotpoint Spares Centre or local Electricity Board. The colour of the correct replacement fuse cover is that of the coloured marks or insert in the base of the plug.

### Mains Lead Replacement

If the mains lead on this appliance needs replacing at any time, it must be replaced by a lead which is obtainable from your nearest Hotpoint Service Office (see back page). A charge will be made for the replacement of the mains lead if you have damaged the lead or require a longer lead.

### WARNING:

**AVOID ACCIDENTS TO CHILDREN. WHEN DISCARDING AN OLD FRIDGE OR FREEZER BE CERTAIN TO MAKE THE LOCK UNSUSABLE. DO NOT ATTEMPT TO STAND ON TOP OF YOUR APPLIANCE. IT IS NOT DESIGNED FOR SUCH USE AND YOU COULD INJURE YOURSELF OR DAMAGE THE APPLIANCE BY SUCH ABUSE. CHILDREN SHOULD NOT BE ALLOWED TO PLAY WITH THE APPLIANCE OR TAMPER WITH THE CONTROLS.**

## Hotpoint Service Cover

### Hotpoint's Free Five Year Guarantee

From the moment your appliance is delivered, Hotpoint guarantees it for **FIVE YEARS**.

- In the Five Years all replacement parts are **FREE** provided they are fitted by our own Service Engineer. During the first year our Engineer's time and labour is also free. Our Guarantee also covers loss of food in our Refrigeration and Freezer products up to £250 during the first year.
- After the first year we will charge for our Engineer's time and labour. We do, however, operate a range of Service Plans (see opposite) which for an annual payment enable you to cover any repair costs which may be necessary.
- All our service repairs are guaranteed for twelve months in respect of our labour and any parts fitted.
- The appliance must not be used in the United Kingdom and must not be tampered with or taken apart by anyone other than our own Service Engineer.
- You may, however, buy parts which can be safely fitted without specialist knowledge or equipment. The correct fitting of such parts, provided they are genuine Hotpoint spares, will not affect your Guarantee. Parts are available from our main Hotpoint Spares Centres (see back page).
- Our Guarantee does not cover the cost of any repair which is needed because of power cuts, accidents or misuse. Nor does it cover the cost of any visit to advise you on the use of the appliance. Please read the instruction book thoroughly.
- If at any time during the Guarantee period we are unable to repair your appliance, we will refund any repair costs paid to us in the previous twelve months. We will also offer you a new appliance at a reduced charge instead of a repair.
- Our Guarantee is in addition to and does not affect your legal rights.
- Should you need independent advice on your consumer rights, help is available from your Consumer Advice Centre, Law Centre, Trading Standards Department and Citizens Advice Bureau.
- All Hotpoint servicing is done by our own Service Organisation located throughout the United Kingdom and Southern Ireland. They will be happy to deal with any problems.

### Hotpoint's Service Care

Whether you have just one or a number of Hotpoint appliances in your kitchen Hotpoint has a range of Service Schemes to give you complete peace of mind.

### Service Cover

One annual payment covers you for all repairs for **individual appliances**. Service Cover also covers loss of food up to the value of £250 in our refrigeration and freezer products. If two or more appliances are covered a 20% reduction is made on each fee. There is also the option of **Service Cover with Maintenance** at additional cost and both Cover Plans are renewable each year by mutual agreement.

To make sure that you have the opportunity to participate in this Plan, please complete and post the enclosed Application for Hotpoint Service Cover Plan with your remittance to your nearest Hotpoint Service Office.

### Kitchen Cover

One annual payment covers you for all Repairs and a Maintenance Check for **all Hotpoint appliances owned** which are less than ten years old. Kitchen Cover also covers loss of food up to the value of £250 in our refrigeration and freezer products. Any additional Hotpoint appliances purchased after you have joined **Hotpoint Kitchen Cover** will automatically be included during the current annual period of cover without any further charge.

Full details and costs of these Service Plans can be obtained from your local Service Office (see back page).

### Annual Safety/Maintenance Checks

Hotpoint strongly recommends that all its appliances are regularly checked for electrical and mechanical safety whether or not they are covered by a Service Plan.

### Proof of Purchase

For future reference please attach your purchase receipt to this booklet and keep it in a safe place.

### Spares and Accessories

Spares and accessories can be ordered from your local Hotpoint Spares Centre (listed on the back page), using the order form enclosed.

## If your Fridge Freezer won't work

- ... don't panic  
Just run through these quick checks before calling your nearest Hotpoint Service Office.
1. Check that the plug is firmly in the wall socket and that the power supply is on.
  2. Check the power supply to the socket by plugging in another appliance.
  3. If the other appliance works, check the fuse in the fridge freezer plug.
  4. If you have changed the plug, check the wiring (see page 2).
  5. If the interior light fails to work, refer to page 17 for further instructions.
  6. If water appears down the inside back of the fridge compartment, check that the defrost drain has not become blocked.
  7. If the temperature in the compartment is not cold enough, check that:
    - the doors are properly shut
    - the thermostat is in the correct position
    - the appliance is not too close to a heat source
    - the back compressor is clean
    - the air flow is not restricted.
  8. If the temperature in the refrigerator compartment is too cold check that the thermostat is in the correct position.
  9. The appliance is excessively noisy. Check that:
    - the appliance is not in contact with adjacent fittings which may cause noise due to vibration
    - the refrigeration system pipework at the rear of the cabinet is not vibrating or the pipes do not touch each other
    - all four feet are firmly in contact with the ground (see page 5).
  10. The interior light does not work. Check that:
    - there is not a power failure
    - the light bulb has not failed (see Page 17).
- If, after following all these instructions, you are still having problems, contact your nearest Hotpoint Service Office (or local importer if outside the United Kingdom). The telephone number is shown on the back page.
- When you contact us we need to know:
1. Your name, address and post code.
  2. Your telephone number.
  3. Clear and concise details of the fault.
  4. The model number (8350), and colour.
  5. When it was purchased. Please put the date here
- .....
6. If you have subscribed to the Hotpoint Service Plan (see next page).  
Make sure you have all these details before you call.

## Contents

<b>THIS BOOK COVERS MODEL 8350</b>	<b>Page</b>
<b>Get to know your Fridge Freezer</b>	<b>4</b>
<b>Installing your Fridge Freezer</b> Where to put your fridge freezer	<b>5</b>
<b>Repositioning the Door Hinges</b>	<b>6</b>
<b>Getting your Fridge Freezer ready for use</b> Starting and Running In	<b>9</b>
<b>Adjustable/Tilting Shelves</b>	<b>10</b>
<b>Controlling the Temperature</b>	<b>11</b>
<b>Storing Food</b> Storing food in the fridge compartment Storing frozen food in the freezer compartment Freezing fresh foods – maximum freezing loads and how to freeze them The Ice Service Do's and Don'ts	<b>12-15</b>
<b>Caring for your Fridge Freezer</b> Defrosting Cleaning Going Away Replacing the interior light	<b>16-17</b>
<b>If your Fridge Freezer won't work</b>	<b>18</b>
<b>Hotpoint Service Cover</b>	<b>19</b>
<b>Hotpoint Service Offices and Spares Centres</b>	<b>Back Page</b>

## Retention of the Instruction Book

This Instruction Book must be kept handy for reference as it contains important details on the safe and proper use of the appliance.  
If you sell or pass the appliance to someone else, or move house and leave it behind, make sure this Book is also provided so the new owner can become familiar with the appliance and safety warnings.  
If the Book is lost or damaged a copy may be obtained from Hotpoint Ltd, Celta Road, Peterborough, PE2 9UB.

## Get to know your Fridge Freezer

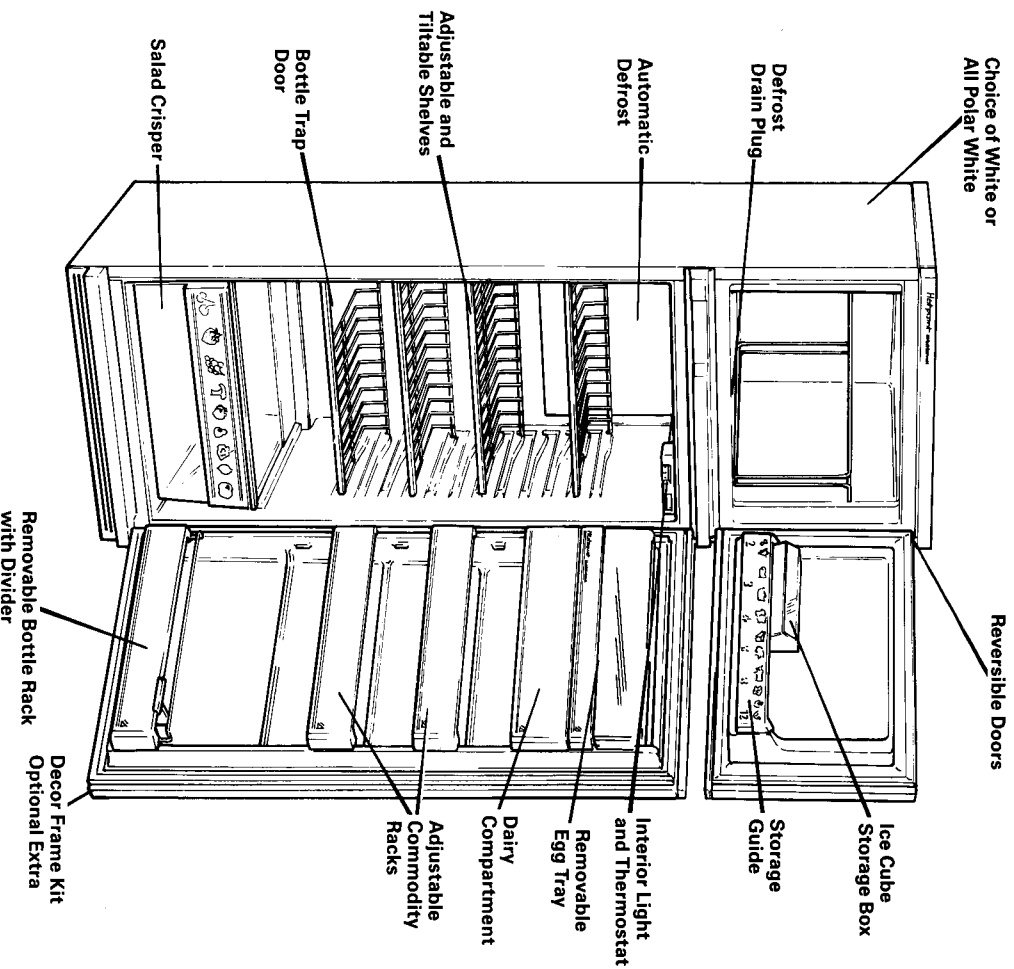

Model 8350

## Caring for your Fridge Freezer (cont.)

### Cleaning your fridge freezer

It is a good idea to clean the inside of your fridge freezer after defrosting. Always **switch off and pull out the mains plug** first. Wipe out the inside of the fridge freezer using a clean cloth wrung out in either a solution of one teaspoonful of bicarbonate of soda to one pint of water or Milton diluted according to the manufacturer's instructions. The complete interior including the door, and removable parts, should be washed. **Never** use any household cleaner or detergent, abrasive powders or wax polish. These not only damage the surfaces, but also leave a smell in the fridge freezer. Make sure that no particles of food are left in the gutter in the fridge compartment. Before you refill the fridge freezer ensure it is thoroughly dry.

Clean the outside of the fridge freezer, **but not the door seal**, with a damp cloth, using a small amount of detergent, followed by a wipe down with a clean cloth. Do not use an abrasive powder. **The rubber door seal must be cleaned with soap and water only as detergent will damage it.**

Finally, the compressor and condenser at the back of the fridge freezer can be carefully cleaned. Use a brush or vacuum cleaner to remove any dust. Always check that the fridge freezer is disconnected from the mains when doing this. Remember to replace the mains plug and switch on after cleaning your fridge freezer.

### Going away

If you expect to be away for any length of time and don't want to use the fridge freezer switch off at the power point and pull out plug. Remove all the food from both fridge and freezer, follow the defrosting instructions. (See page 16). Always leave the doors ajar to prevent the accumulation of odours.

### How to replace the interior light

Should the light fail to work, **switch off and pull out the mains plug**, then ensure the bulb is screwed securely into the bulb holder. Replace the plug and switch on. If the light still fails to work, do not worry, it will not affect the working of your fridge freezer. Obtain a replacement SES 15 Watt bulb from a local electrical retailer or your nearest Hotpoint Spares Centre and then fit it as follows:

### Switch off and pull out the mains plug.

Remove any items off the fridge top shelf.  
To remove the light cover gently press the top of the cover and remove the cover completely.  
Unscrew the old bulb and fit a new one.  
Refit the interior light cover by placing the base hinges of the light cover into the fixing position and press the top section of the light cover into position. Ensure that the cover is secure.  
Replace the items on the shelf.  
Replace the plug into the mains socket outlet and switch on the appliance.

## Caring for your Fridge Freezer

### Defrosting the freezer compartment

Excessive frost build-up reduces the efficiency of the freezer compartment. The quantity of ice which builds up inside the freezer depends upon the frequency and length of time the door is opened. When the frost accumulates to a 3mm thickness completely defrost the freezer compartment. You will find you only need to do this about twice a year, depending on usage.

Try to defrost when there is little or no food in the freezer compartment. Defrosting must be carried out as quickly as possible since a rise in the temperature of your frozen food may reduce the recommended storage time. Just follow these steps:

1. **Switch off and pull out the plug from the mains socket outlet.**
2. Remove any frozen food. Wrap it in several layers of newspaper or a blanket and using the storage baskets position in a cool place.
3. Remove the drain cap (Fig 8) which is in the base of the freezer compartment.

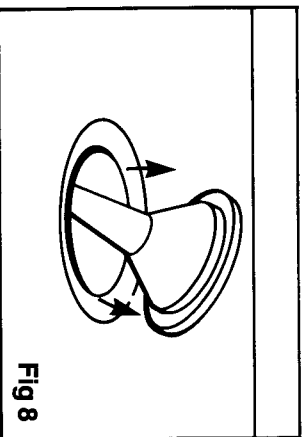

Fig 8

4. Position a shelf in the top shelf position in the refrigerator.
5. Place a bowl of at least 3 litre capacity in the centre of the shelf directly beneath the drain aperture.

16

This will collect the defrost water from the freezer section above.

6. Place a bowl of warm water (50°C approx) in the freezer compartment and leave the door open.
7. Use the plastic scraper supplied with the appliance to remove the ice. **DO NOT** use sharp metal tools to chip the frost away – they will damage the freezer compartment.
8. After the ice has melted sponge out any excess water or ice from the freezer compartment.
9. Replace the freezer compartment drain plug securely in position.
10. Remove the bowl of water from the refrigerator compartment. Replace the shelf to its normal shelf position.
12. Replace the plug in the mains socket outlet and switch on.
13. Unwrap the frozen food and replace. Close the door.

### The fridge compartment

The fridge compartment will automatically defrost itself and the defrost water will drain out through the hole in the gutter and into a special container where it evaporates. Water droplets will form on the cooling plate during the defrost periods and will freeze on the plate afterwards. If your kitchen becomes exceptionally warm the cooling plate may not defrost regularly. Do not worry. Periodic defrosting will begin again when conditions return to normal. Do make sure that the gutter is always kept clear and that stored food does not come into contact with the cooling plate.

## Installing your Fridge Freezer

### Where to put your fridge freezer

Your fridge freezer should be placed where it is easy to use, alongside/ adjacent to a work surface is often a good position. **Do not** place the appliance close to anything which gives off heat for example: cookers, boilers, radiators, or in a position where direct sunlight is liable to shine directly onto the appliance.

If the appliance is to be positioned underneath wall cupboards ensure that there is a 50 mm (2") gap between the top of the appliance and the underside of kitchen units. Once you have decided upon the most suitable position to place the appliance fit the two wall spacers supplied to the top rear of the appliance (see Fig 1).

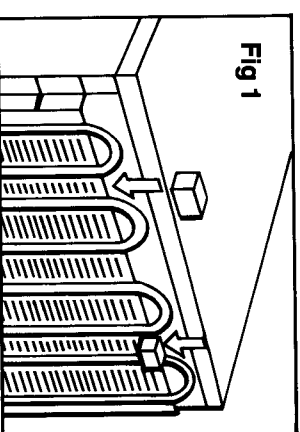

Fig 1

It is important that the appliance is correctly levelled. To do this turn the adjustable front feet (see Fig 2) clockwise or anti-clockwise until all four feet are firmly in contact with the floor. Correct adjustment avoids excessive vibration and noise.

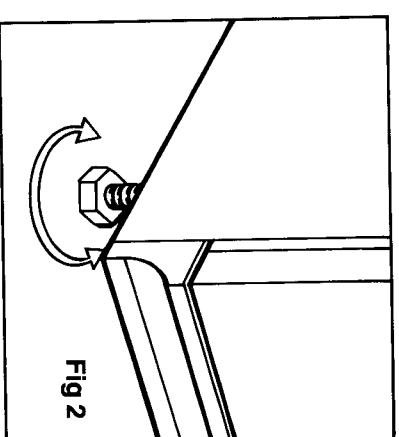

Fig 2

The door support (Fig 3) is fitted for delivery purposes only and should be removed when the appliance is installed.

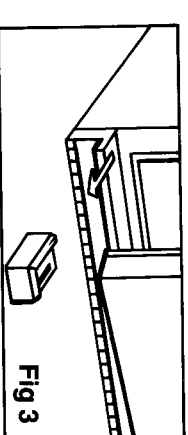
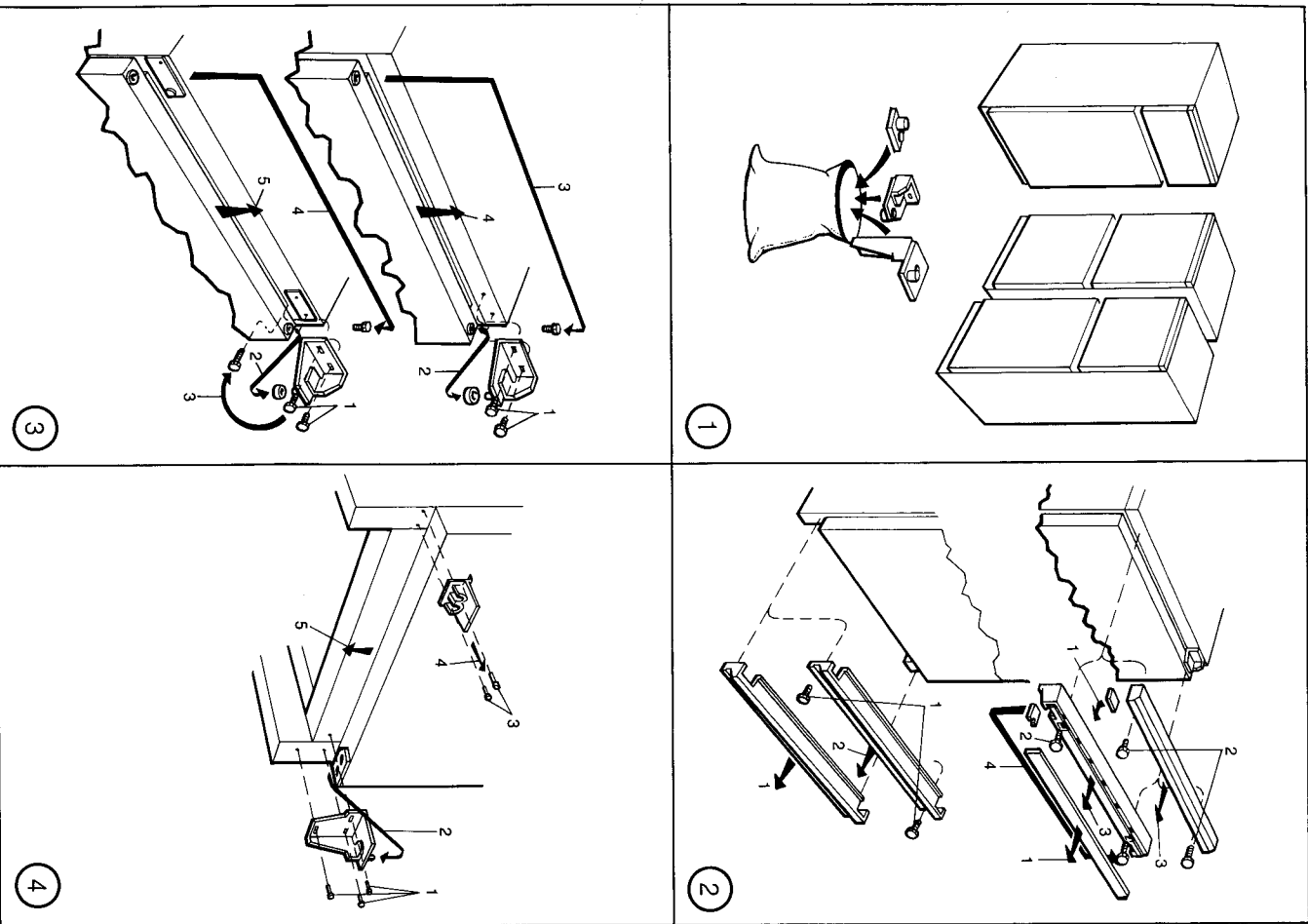

Fig 3

The rating plate is situated in the refrigerator adjacent to the salad bin. The rating plate should be referred to for any technical data information.

## Repositioning the Door Hinges



## Do's and Don'ts (cont.)

### DON'T

#### Fridge compartment

**Don't:-** Store cooked and fresh food together in the same container. They should be packaged and stored separately.

**Don't:-** Store bananas in the fridge compartment.

**Don't:-** Store melon in the fridge compartment. It can be chilled for short periods as long as it is wrapped to avoid it flavouring other food.

**Don't:-** Wash eggs as this removes their natural protective film. Wipe them instead.

**Don't:-** Use eggs straight from the fridge compartment, especially when making cakes or mayonnaise. Allow them to reach room temperature before use.

**Don't:-** Leave the door open for long periods as this will make the fridge compartment more costly to run and also affect the internal temperature of the fridge.

**Don't:-** Cover the shelves with any protective materials which may obstruct air circulation through them.

**Don't:-** Let anything touch the cooling plate at the back of the fridge compartment.

**Don't:-** Store poisonous or dangerous substances in the fridge. Your fridge has been designed for the storage of edible foodstuffs only.

**Don't:-** Consume food which has been stored for an excessive time in the fridge.

**Don't:-** Let defrosting food or food juices drip onto food in your fridge.

#### Freezer compartment

**Don't:-** Exceed the maximum freezing loads when freezing fresh food (see page ).

**Don't:-** Put hot food into the freezer or even in the fridge compartment. Let it cool down first.

**Don't:-** Leave the door open for long periods as this will cause excessive ice formation and make the freezer compartment more costly to run.

**Don't:-** Put liquid-filled bottles or sealed cans containing carbonated liquids (fizzy drinks, etc) into the freezer compartment as they may burst.

**Don't:-** Try to keep frozen food which has thawed; it should be eaten within 24 hours or cooked and refrozen.

**Don't:-** Give children lollipops and water ices direct from the freezer compartment. The low temperature may cause 'freezer burns' on their lips.

**Don't:-** Leave the freezer drain plug out of the drain.

**Don't:-** Store poisonous or dangerous substances in the freezer. Your freezer has been designed for the storage of edible foodstuffs only. Never re-freeze partially or totally thawed foods.

# Do's and Don'ts

## DO

### Fridge compartment

- Do:-** Take off any unusable leaves on vegetables and wipe off any soil.
- Do:-** Leave lettuce, cabbage, parsley and cauliflower on the stem.
- Do:-** Wrap cheese tightly in cling film excluding as much air as possible. For best results take out of the fridge compartment an hour before eating.
- Do:-** Wrap raw meat and poultry loosely in polythene or aluminium foil. This prevents drying.
- Do:-** Wrap fish and offal in polythene bags
- Do:-** Wrap foods which have a strong odour or can dry out in polythene bags, aluminium foil or place in airtight containers.
- Do:-** Wrap bread well to keep it fresh.
- Do:-** Chill white wines, beer, lager and mineral water before serving.
- Do:-** Ensure that cooked foods are allowed to cool before storing in the refrigerator.
- Do:-** Store all liquids in covered containers.
- Do:-** Store food items in the positions recommended by the manufacturers.
- Do:-** Store raw meat and poultry below cooked foods and dairy products.
- Do:-** Clean out your salad drawer regularly.

### Freezer compartment

- Do:-** Always choose high quality fresh food and be sure it is thoroughly clean before you freeze it.
- Do:-** Prepare fresh food for freezing in small portions to ensure rapid freezing.
- Do:-** Remember lean foods last longer than fat foods.
- Do:-** Wrap all foods in aluminium foil or polythene bags and make sure any air is excluded. Keep the door shut when freezing fresh food.
- Do:-** Wrap frozen food when you buy it and put it into the freezer compartment as soon as possible.
- Do:-** Store and use commercially frozen food in accordance with the instructions given on the packets that you buy.
- Do:-** Ensure that fresh food which is frozen is well labelled and dated.
- Do:-** Ensure frozen foods are thoroughly defrosted before cooking unless the instructions on the packet say different.

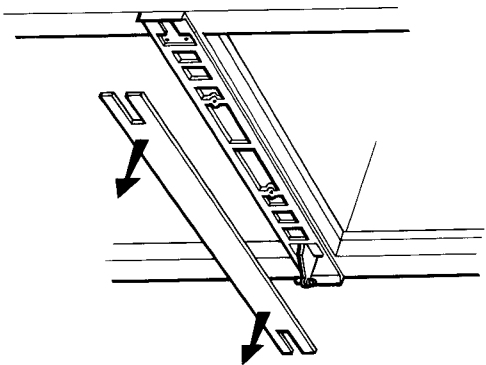

5

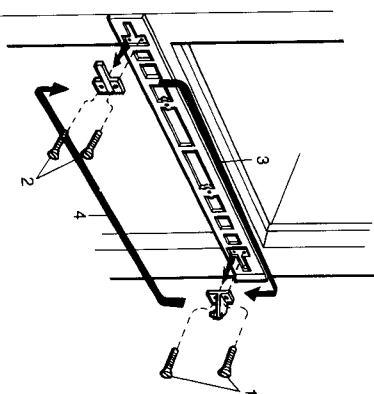

6

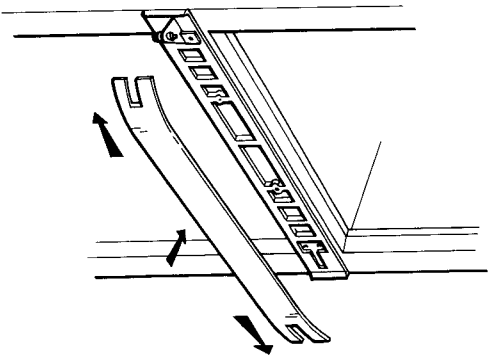

7

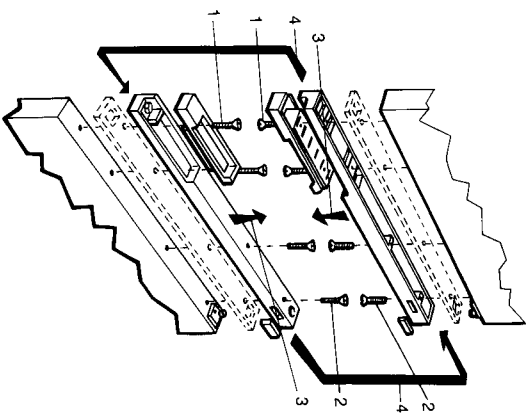

8

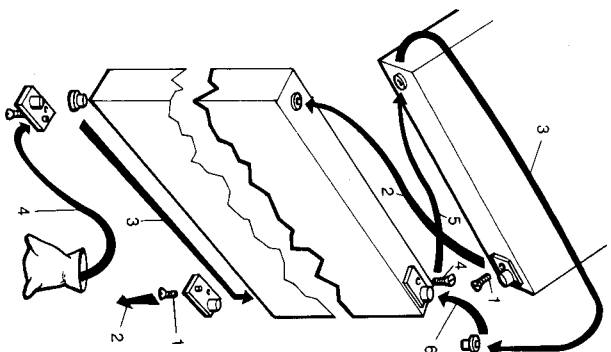

9

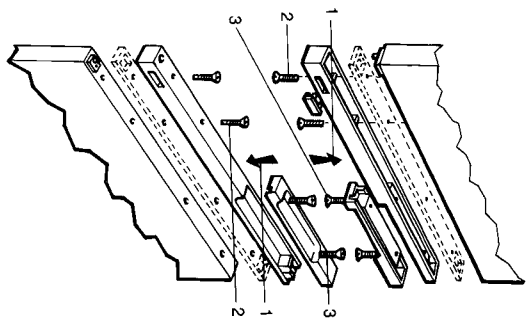

10

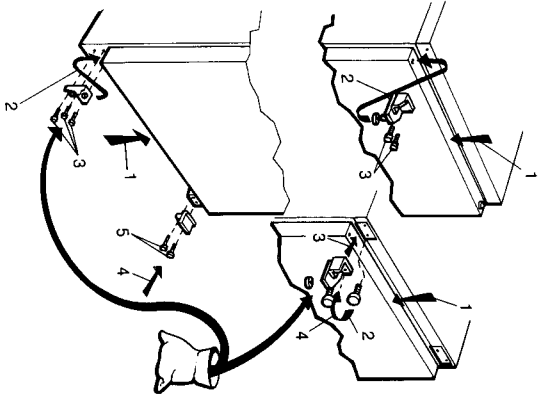

11

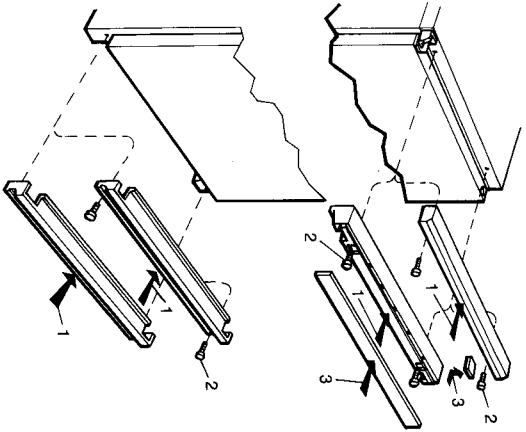

12

## Storing food in the freezer compartment

Your freezer compartment carries the **\*\*\*** symbol which indicates that it is suitable for the long-term storage of commercially frozen foods and also can be used to freeze and store fresh food. Ice cubes can be frozen in the freezer.

The freezer compartment stores up to 19 kg (40 lb) of frozen food.

Generally speaking long-term storage means up to 3 months, but this will vary with the nature of the packaged food, so always follow the manufacturer's recommended storage time given on the packet. For storing home frozen fresh food refer to the pictorial guide on the door liner.

If there is a power failure **do not open the freezer compartment door**. Frozen food should not be

affected if the failure is less than 12 hours. If the failure is longer than the food should be checked and either eaten immediately or cooked and then refrozen.

### Freezing fresh foods

You can freeze up to 4.5 kg (9.9 lb) of fresh or cooked food in any 24 hours. If you are freezing this amount, turn the control dial in the fridge to position 9. Put the fresh food into the fast freezing sections (shaded). See Fig 7.

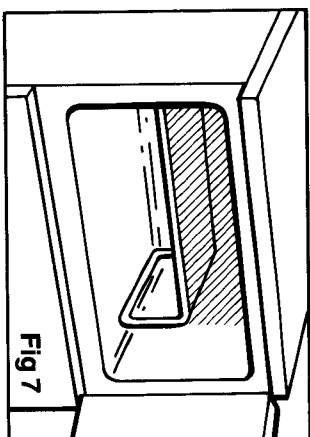

**NOTE:** Use the shelf supplied to separate the already frozen food from foods which are to be fast frozen. Put the fresh food in the fast freezing sections with as much food as possible in contact with the roof and walls. When the freezing is completed (24 hours for 4.5 kg (9.9 lb) of food) turn the control dial in the fridge back to its normal position.

### Ice Cubes

The ice cube trays should be filled to  $\frac{3}{4}$  of their depth. Place in the freezer compartment to freeze. A perspex ice cube storage container is supplied which can be placed in the freezer door commodity rack. Transfer the frozen ice cubes from the ice cube tray into the storage box as and when necessary.



## Storing Food

### Storing food in the fridge

#### compartment

**NOTE:** The coldest section of the refrigerator compartment is immediately above the salad crisper/glass shelf.

You can store most fresh foods in the fridge compartment. Recommended maximum storage times are given in the table below.

		Days
<b>Raw fresh meat</b>	joints, steaks, chops	3-5
	offal (liver, kidney etc) minced meat, sausages	2
<b>Cooked meat</b>	including made-up dishes and left-overs	2-3
	fresh whole (store giblets separately)	2-3
<b>Poultry</b>	giblets	2
	cooked	2-3
<b>Fish</b>	raw	1-2
	cooked	2-3
<b>Bacon</b>		7-10
<b>Milk, cream, salad; vegetables</b>		3-4
<b>Butter, margarine and cooking fats</b>	hard	3-4
	cream	1
<b>Eggs</b>		2

Different types of food are best stored in the recommended positions eg: Meats, sausages and fish: these should be stored above the salad crisper/glass shelf (the coldest part of the fridge).

Cooked foods: pies, meats, jellies etc should be stored on the top shelf.

**NOTE:** Cooked food and raw meat should be well packed and stored separately.

Fruit and vegetables should be stored in the salad crisper.

Eggs, cheese and dairy produce should be stored in the commodity racks in the refrigerator door.

Canned foods: Once the can has been opened, transfer the food into a non-metallic, air tight container.

**NOTE: DO NOT** place food items or containers against the rear internal wall of the fridge. **DO NOT** cover the shelves with paper, foil or plastic.

Foods must be placed on the shelves with space between the items to allow the air within the cabinet to flow freely.

## Getting your Fridge Freezer ready for use

Before using your fridge freezer for the first time the interior, including the door, and all removable parts should be wiped out. Use a damp cloth wrung out in either a solution of one teaspoonful of bicarbonate of soda to one pint of water or Milton diluted according to the manufacturer's instructions.

**WARNING: NEVER USE ANY HOUSEHOLD CLEANER OR DETERGENT, ABRASIVE POWDERS OR WAX POLISH. THESE NOT ONLY DAMAGE THE SURFACES, THEY ALSO LEAVE A SMELL IN THE FRIDGE FREEZER.**

### Final check

Before you start using the fridge freezer, check that

1. it is thoroughly dry inside,
2. air can circulate freely,
3. the feet have been adjusted, ie. all four are firmly on the ground and the machine is level.
4. fit the shelves and racks.

**NOTE: The appliance should be allowed to stand one hour after delivery BEFORE switching on the controls.**

### Starting

Insert the plug into the mains socket outlet and switch on the electricity supply. Open the fridge compartment door and the light will come on. The thermostat control knob is situated adjacent to the interior light on the top interior front of the refrigerator roof (Fig 4).

The control governs the temperature in both the refrigerator and the freezer compartment.

It should be noted that the internal temperatures are affected by the location of the appliance, room temperature and the frequency and length of time the doors are opened.

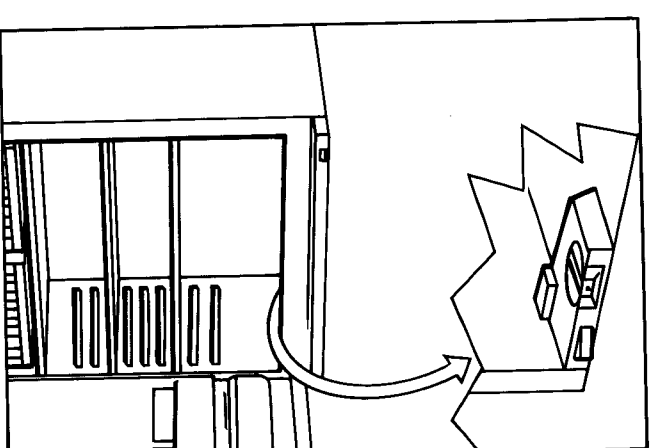

Fig 4

You should not store food in the appliance immediately after switching the control on. Wait at least one hour before storing food in the refrigerator and at least 6 hours before storing food in the freezer section.

### Running-in the compressor

Your fridge freezer is operated by a compressor which switches on and off in order to maintain the fridge freezer's temperature. The compressor is a precision piece of machinery and, like a car engine, requires a running-in period of up to 2 months. During this time the compressor has to work a little harder and this may result in more noise than usual.

## Controlling the Temperature

### Bottle trap door

(See Fig 6.) This enables tall bottles and jars to be stored.

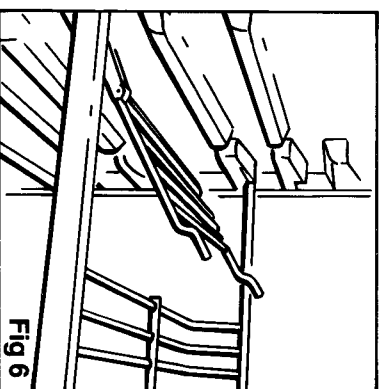

### Adjustable/tilting shelves

The shelving system in the fridge interior has also been designed to provide maximum storage flexibility. It is possible to position the shelves at various heights to suit the items being stored and it is also possible to tilt certain racks thereby allowing safe storage of bottles and jars on their sides. To tilt a rack place the rear of the shelf into position and the front of the shelf slots into the shelf position above (see Fig 5).

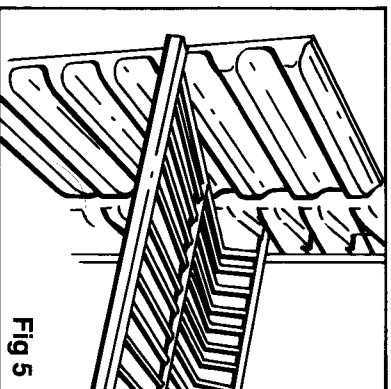

The control dial controls the temperature in both the fridge and freezer compartment and is marked from 0-9. Which setting is selected will depend on where the fridge freezer is located, how often you open the door and the temperature of the room in which the fridge freezer is situated.

The temperature inside your refrigerator should be between 0°C and 5°C, though some sections such as the Salad Crisper will be warmer.

If using a fridge thermometer to check the temperature, it should be left overnight on the centre of the middle shelf. If the temperature reading is not between 0°C and 5°C then the controls should be adjusted accordingly or it may be that defrosting is required.

### NOTE: Do not use a thermometer which contains mercury.

If you do not have a fridge thermometer the best way to check that the fridge section is operating at the correct temperature is to set the thermostat control to the setting which just starts to make your milk freeze. Once this has been found turn the control back to a slightly lower setting until the milk stops freezing.

### Controlling the temperature inside the fridge compartment

Rotate the control knob to select the setting you require. You will hear a noise as the compressor starts up. A control setting of 4 is usually suitable, but if you find the interior of the fridge compartment is too warm turn the control to a colder setting (higher number). Similarly, if you find the interior is too cold, ie the milk begins to freeze, turn the control to a warmer setting (lower number).

### Controlling the temperature inside the freezer compartment

The control knob situated within the refrigerator controls the temperature within the freezer.

When the fridge compartment temperature has been set the freezer compartment will automatically be maintained at the correct

temperature necessary for **\*\*\*\*** frozen food storage (see Storing Food in your freezer compartment – page 13).

Control setting 9 is recommended for the fast freezing of frozen food (see page 13).

If the room is cold or humid, water droplets may form on the outside of the fridge freezer. If this happens do not worry, as they will disappear when conditions return to normal. In the summer months, or in conditions giving high temperatures around the fridge freezer the compressor has to work harder and run for longer periods. This is quite normal. Conversely during cold conditions the compressor will run for much shorter periods.