

Instruction manual

HP FRAMER

HIGH PRESSURE®

ROUND HEAD FRAMING NAILER



MODEL FRP350

IMPORTANT

Please make certain that the person who is to use this equipment carefully reads and understands these instructions before starting operations.

The Model and Serial No. plate is located on the main housing of the tool. Record these numbers in the spaces below and retain for future reference.

Model No. _____

Type _____

Serial No. _____

To learn more about Porter-Cable
visit our website at:

<http://www.porter-cable.com>

PORTER-CABLE
PROFESSIONAL POWER TOOLS

TABLE OF CONTENTS

SAFETY GUIDELINES AND INSTRUCTIONS	3
GENERAL SAFETY RULES	4
EMPLOYER RESPONSIBILITIES & FUNCTIONAL DESCRIPTION	7
CARTON CONTENTS & PREPARING THE TOOL	7
OPERATING INSTRUCTIONS	9
MAINTENANCE	12
SERVICE & TROUBLESHOOTING	13
ACCESSORIES & WARRANTY	14
ESPAÑOL	15
FRANÇAISE	27
SERVICE CENTER LISTING	BACK COVER



PORTER-CABLE

PROFESSIONAL POWER TOOLS

4825 Highway 45 North • Jackson, TN 38305

Telephone: 1-800-487-8665

GB ENGLISH

EC-DECLARATION OF CONFORMITY

We declare under our sole responsibility that this product is in conformity with the regulations EN292-2: section 3 of 1992

EN292-1: section 5 of 1992

EN1050: 1993

EN792 13: 2000

E ESPAÑOL

DECLARACION DE CONFORMIDAD "CE"

Declaramos bajo nuestra sola responsabilidad que este producto está en conformidad con las regulaciones

EN292-2: section 3 of 1992

EN292-1: section 5 of 1992

EN1050: 1993

EN792 13: 2000

F FRANÇAISE

DÉCLARATION DE CONFORMITÉ CE

Nous déclarons sous notre propre responsabilité que ce produit est conforme aux réglementations

EN292-2: section 3 of 1992

EN292-1: section 5 of 1992

EN1050: 1993

EN792 13: 2000

Robert F. Burkholder

Sr. Vice President of Technology

Date of Manufacture: _____

Fecha de fabricación:, Date of fabrication:

Serial No: _____

Número de serie:, Nombre d'ordre

SAFETY GUIDELINES / DEFINITIONS

It is important for you to read and understand this manual. The information it contains relates to protecting YOUR SAFETY and PREVENTING PROBLEMS. The symbols below are used to help you recognize this information.

- ▲ DANGER** indicates an imminently hazardous situation which, if not avoided, will result in death or serious injury.
- ▲ WARNING** indicates a potentially hazardous situation which, if not avoided, could result in death or serious injury.
- ▲ CAUTION** indicates a potentially hazardous situation which, if not avoided, may result in minor or moderate injury.
- CAUTION** used without the safety alert symbol indicates potentially hazardous situation which, if not avoided, may result in property damage.

IMPORTANT SAFETY INSTRUCTIONS

SAVE THESE INSTRUCTIONS!

▲ WARNING Read and understand all warnings and operating instructions before using any tool or equipment. When using tools or equipment, basic safety precautions should always be followed to reduce the risk of personal injury. Improper operation, maintenance or modification of tools or equipment could result in serious injury and property damage. There are certain applications for which tools and equipment are designed. Porter-Cable Corporation strongly recommends that this product NOT be modified and/or used for any application other than for which it was designed.

If you have any questions relative to its application DO NOT use the product until you have written Porter-Cable Corporation and we have advised you.

Online contact form at www.Porter-Cable.com

Postal Mail: Technical Service Manager
Porter-Cable Corporation
4825 Highway 45 North
Jackson, TN 38305

Information regarding the safe and proper operation of this tool is available from the following sources:

International Staple, Nail and Tool Association (ISANTA)
512 W. Burlington Ave., Suite 203, La Grange, IL 60525-2245
www.isanta.org

American National Standards Institute, 25 West 43rd Street, 4 floor, New York, NY 10036 www.ansi.org

ANSI SNT-101-2002 Safety Requirements for Portable, Compressed-Air-Actuated Fastener Driving Power Tools

⚠ DANGER
GENERAL SAFETY RULES

1. Read and understand tool labels and manual. Failure to follow warnings could result in **DEATH** or **SERIOUS INJURY**. Fig. 1.

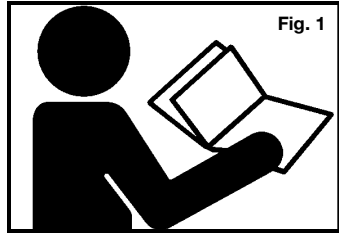

2. Operator and others in work area MUST wear safety glasses with side shields. These safety glasses must conform to ANSI Z87.1 requirements (approved glasses have “Z87” printed or stamped on them). Fig. 2.

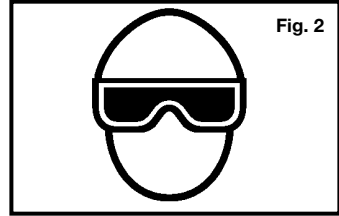

3. Keep fingers AWAY from trigger when not driving fasteners to avoid accidental firing. Never carry tool with finger on trigger. Contact actuation tools will fire a fastener if the safety mechanism is bumped while the trigger is depressed.

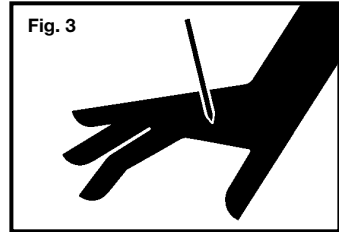

4. Choice of triggering method is important. Check manual for triggering options. See “Using the Tool” section of this manual.

5. Never point tool at yourself or others in work area. Serious injury or death may occur if the tool is activated. Fig. 3

6. Never use oxygen or other bottled gasses. Explosion will occur. Never use combustible gases or any other reactive gas as a power source for this tool: explosion and serious personal injury will result. Fig. 4.

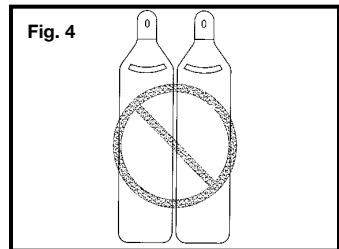

7. Wear ear protection to safe-guard against possible hearing loss. Ear protection equipment must conform to ANSI S3.19 requirements. Fig. 5.

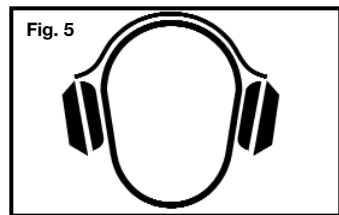

8. Use clean, dry, regulated, compressed air at 80 to 150 PSI, (5.5 to 10.3 BAR). Fig. 6.

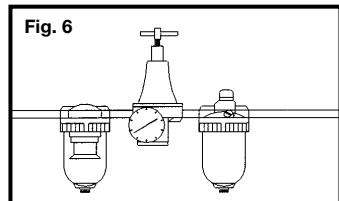

9. Do not connect tool to pressure which potentially exceeds 200 PSI (13.7 BAR).

10. All air line components (hoses, connectors, filters, regulators, etc.) must be rated for a maximum working pressure of at least 300 PSI (20.7 BAR) or 150% of the maximum system pressure, whichever is greater.

11. Connect tool to air supply hose with a coupling that automatically removes all pressure from the tool when the coupling is disconnected. Fig. 7.

12. Disconnect tool from air supply hose before doing tool maintenance, clearing a jammed fastener, leaving work area, moving tool to another location, or handing the tool to another person. Fig. 7.

13. Never use a tool that is leaking air, has missing or damaged parts, or requires repair. Make sure all screws and caps are securely tightened. Fig. 8.

14. Never use tool if safety, trigger or springs are inoperable, missing or damaged. Do not alter or remove safety, trigger, or springs. Make daily inspections for free movement of trigger and safety mechanism. Fig. 8.

15. Do not use tool without safety warning label. If label is missing, damaged or unreadable, contact the Customer Care Department at 1-800-487-8665 for a replacement. Fig. 9.

16. Only use parts and accessories approved by Porter-Cable.

17. Connect tool to air supply before loading fasteners, to prevent a fastener from being fired during connection. The tool driving mechanism may cycle when tool is connected to the air supply. Fig. 10.

18. Always assume the tool contains fasteners. No horseplay. Respect the tool as a working implement. Fig. 11.

19. Operator and bystanders should wear hard hats to safeguard against possible injuries. Fig. 12.

20. Keep bystanders and children away from work area when operating this power tool.

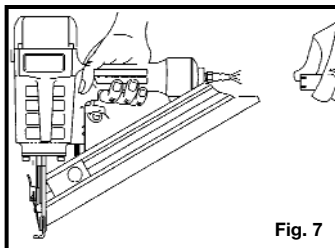

Fig. 7

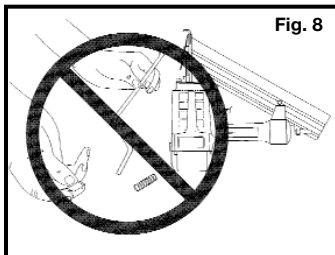

Fig. 8



Fig. 9

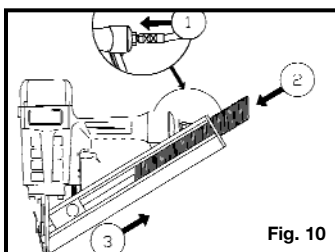

Fig. 10

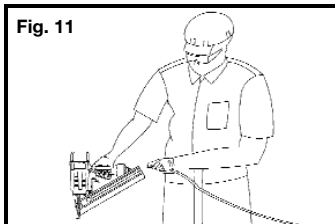

Fig. 11

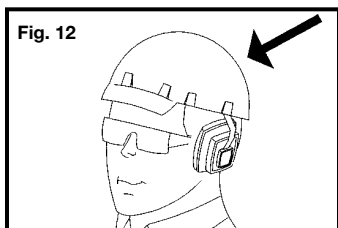

Fig. 12

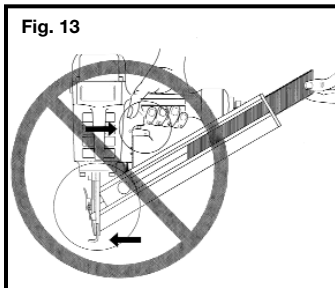

Fig. 13

21. Do not load fasteners with trigger or safety depressed, to prevent unintentional firing of a fastener. Fig. 13

22. Remove finger from trigger when not driving fasteners. Never carry tool with finger on trigger. Contact Actuation tools will fire a fastener if the safety mechanism is bumped while trigger is depressed. Fig. 14.

23. Do not overreach. Keep proper footing and balance at all times when using or handling the tool.

24. Fire fasteners into work surface only: never into materials too hard to penetrate. Fig. 15.

25. Grip tool firmly to maintain control while allowing tool to recoil away from work surface as fastener is driven. With Contact Actuation tools an unwanted fastener will be fired if the safety mechanism is allowed to recontact work surface before trigger is released.

26. Do not drive fasteners on top of other fasteners, or with the tool at too steep an angle: the fasteners can ricochet causing personal injury. Fig. 15.

27. Do not drive fasteners close to the edge of the workpiece. The workpiece is likely to split allowing the fastener to fly free or ricochet causing personal injury. Fig. 16.

28. FOR TOOLS USED IN CONTACT ACTUATION MODE, Do not use on scaffoldings or ladders or for tasks in which changing location involves the use of scaffoldings, stairs, ladders, and the like. Do not use for specific tasks such as closing boxes or crates or fitting transportation safety systems on vehicles and wagons. Fig. 17.

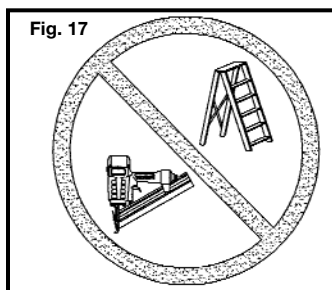
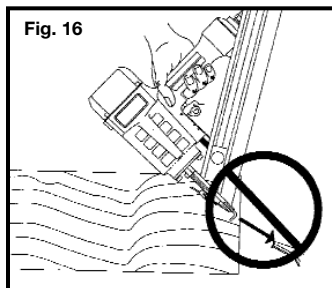
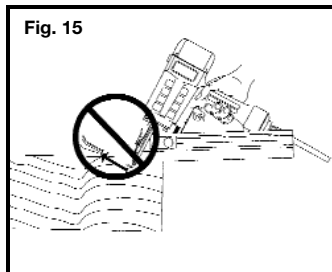
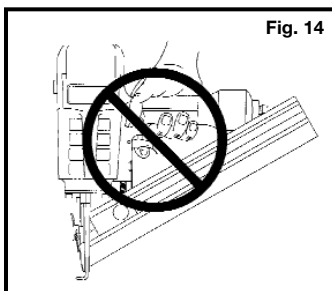

TECHNICAL SPECIFICATIONS

Noise level

A - Weighted sound impulse . . .
power level 105 dBA

P - Emission sound pressure
pressure level 98 dBA

Typical Mean

effective Acceleration 4.9 m/s²

EMPLOYER'S RESPONSIBILITIES

Employer must enforce compliance with the safety warnings and all other instructions contained in this manual.

Keep this manual available for use by all people assigned to use this tool.

For personal safety and proper operation of this tool, read and understand tool labels and manual. Failure to follow warnings could result in DEATH or SERIOUS INJURY. Read and follow all of these instructions carefully.

FUNCTIONAL DESCRIPTION

Porter-Cable **HP FRAMER HIGH PRESSURE®** Model FRP350 is a high pressure heavy duty pneumatic framing nailer. It is designed to install 22 degree round head, plastic collated framing nails .113" - .148" dia. of various lengths from 2" to 3¹/₂".

Use approved Porter-Cable fasteners only.

CARTON CONTENTS

- | | |
|-----------------------------|------------------------|
| 1) HP FRAMER HIGH PRESSURE® | 3) Air Tool Oil Bottle |
| 2) 3/8" NPT plug with cap | 4) Instruction Manual |

POWER SOURCE

This tool is designed to operate on clean, dry, compressed air at regulated pressures between 80 and 150 PSI (Pounds per Square Inch)(5.5 to 10.3 BAR). The preferred system would include a filter, a pressure regulator, and an automatic oiler located as close to the tool as possible, within 15 ft/4.6 m is ideal. The tool is equipped with a 3/8" male quick connector.

All compressed air contains moisture and other contaminants that are detrimental to internal components of the tool. An air line filter will remove most of these contaminants and significantly prolong the life of the tool. If an in-line oiler is not available: place five or six drops of Air Tool Oil into the tool's air inlet at the beginning of each workday.

PREPARING THE TOOL

NOTE: This tool is shipped completely assembled. No assembly time or tools are required.

1. After reading and understanding this entire manual, connect tool to air supply (Fig. 18).
2. Orient a strip of approved fasteners with points down (A) Fig. 19, align, and insert into the magazine "T" slot. **Points first.**
▲ DANGER Do not load fastener strip into magazine backwards.
3. Observe fastener icon (A) Fig. 20. Insert fasteners (B) Fig. 20 with points down (C) Fig. 20. Slide fasteners forward to the front of the magazine. The magazine will hold two full strips of fasteners.

IMPORTANT: Fasteners must point in the same direction as they will be driven.

NOTE: This tool has a mechanical lock out device which restricts the tool from firing when the quantity of nails in the magazine is reduced to four. When attempting to unload the magazine be certain to remove all four nails from the magazine, otherwise one loose nail could jam in the magazine when the tool is reloaded and fired.

4. Feed the strip of fasteners into the magazine ("T" slot), until they are past the spring (A) Fig. 21.
5. Pull the follower (B) Fig. 22 all the way to the rear of the magazine and release. The follower will apply pressure to the strip of nails to feed it into the driving mechanism as shown in (B) Fig. 22A .
6. Adjust directional exhaust deflector (A) Fig. 23 so that the exhaust air blast or debris will be directed away from the operator. The exhaust deflector provides seven detented positions for directing the exhaust blast away from the operator. Grasp the deflector and rotate it to the desired position for the current application.

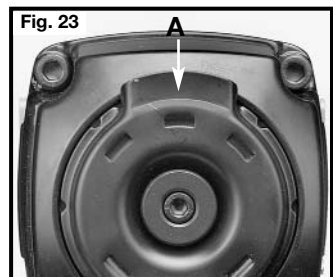
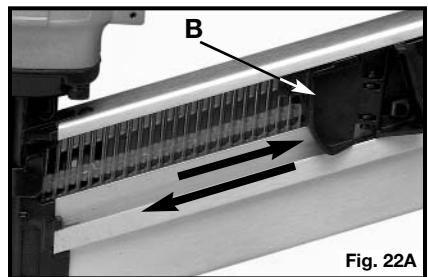
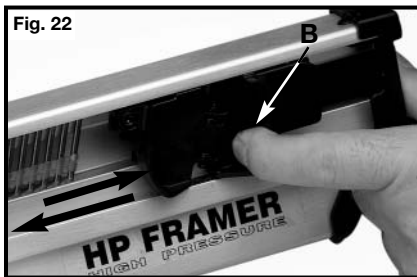
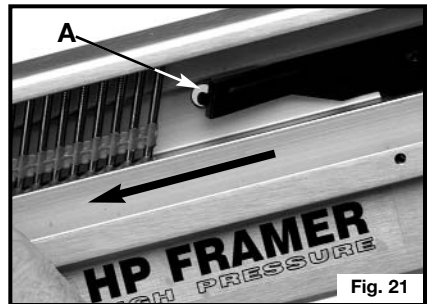
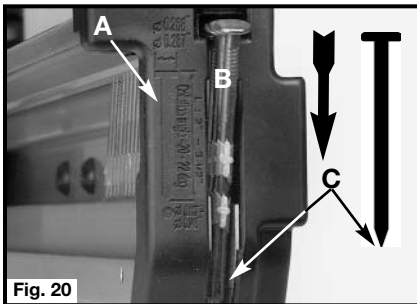
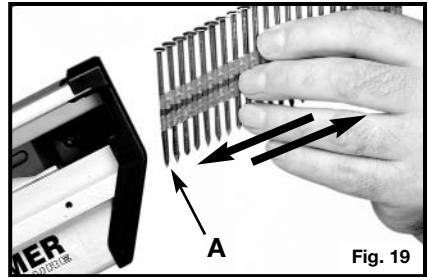
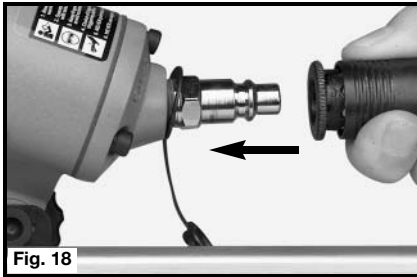

OPERATING INSTRUCTIONS

USING THE TOOL WITH SELECTABLE TRIGGERING OPTIONS

Complete all steps of PREPARING THE TOOL before using the tool.

This tool is shipped from the factory with a selectable trigger set in the **“SINGLE SEQUENTIAL ACTUATION”** firing mode as described in number 1 below. This actuation design requires the release of both the trigger and safety mechanism after each fastener is driven. The selectable trigger can be set for the **“CONTACT ACTUATION”** firing mode as described in number 2 below. This actuation design requires the release of the safety mechanism **ONLY** after each fastener is driven.

1. To use the tool in the **SINGLE SEQUENTIAL ACTUATION MODE** depress trigger lever pivot pin (A) Fig. 24 and rotate it to position (B) and release. Note: Trigger lever pivot pin is spring loaded and held in position by locking tab (D) Fig. 24 to prevent movement during operation. **To fire, grip tool firmly to maintain control, position nose of tool onto work surface, push the tool firmly against work surface to depress safety mechanism, as shown at (S) Fig. 24A, and then squeeze trigger to fire a fastener. Allow tool to recoil away from work surface as fastener is driven. This “single sequential actuation” method provides the most accurate fastener placement.**

-OR-

2. To use the tool in the **CONTACT ACTUATION MODE** depress trigger lever pivot pin (A) Fig. 24 and rotate it to position (C) and release. Note: Trigger lever pivot pin is spring loaded and held in position by locking tab (D) Fig.24 to prevent movement during operation. **To fire, grip tool firmly to maintain control, squeeze and hold trigger, push the tool firmly against work surface to depress safety mechanism, as shown at (S) Fig. 24A, and fire a fastener. Allow tool to recoil away from work surface as fastener is driven.** If safety mechanism is allowed to recontact work surface before trigger is released an unwanted fastener will be fired. The tool will fire a fastener each time the safety mechanism is depressed. This method is known as **“contact actuation”** and allows very fast repetitive fastener placement.

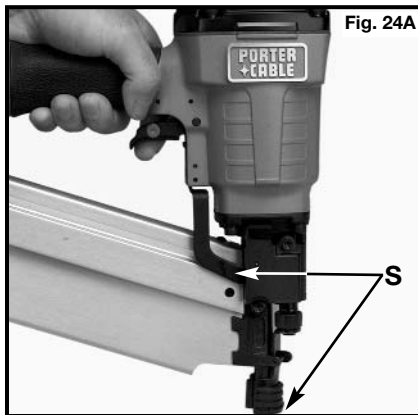
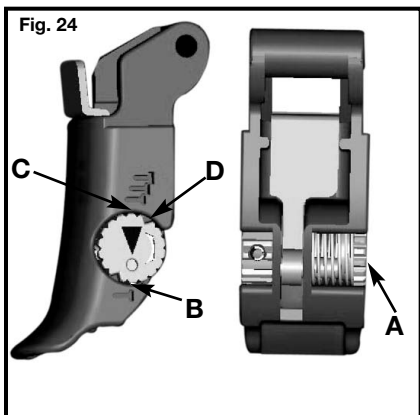

IMPORTANT: A trigger, which will **limit** the tool to “**single sequential actuation**” only, is available free-of-charge by calling 1-800-321-9443 in the United States and Canada or 001-731-660-9374 outside the United States and Canada, and providing tool model number, type, serial number, etc. For identification purposes: the **single sequential actuation** trigger is red.

⚠ WARNING Disconnect tool from air supply before performing maintenance, clearing a jammed fastener, leaving work area, moving tool to another location, or handing the tool to another person.

⚠ WARNING Clean and inspect tool daily. Carefully check for proper operation of trigger and safety mechanism. **Do Not** use the tool unless both the trigger and the safety mechanism are functional, or if the tool is leaking air or needs any other repair.

The depth to which a fastener is driven is controlled by the depth adjustment knob (A) Fig. 25. The depth of drive is factory adjusted to a nominal setting. Test fire a fastener and check depth. If a change is desired, rotate the adjustment knob (A) Fig. 25. The adjustment knob has detents every 1/4 turn. Rotate the knob (A) Fig. 25 counterclockwise to increase the depth of drive, rotate the knob clockwise to decrease the depth of drive. Test fire another fastener and check depth. Repeat as necessary to achieve desired results. The amount of air pressure required will vary depending on the size of the fastener and the material being fastened. Experiment with the air pressure setting to determine the lowest setting that will consistently perform the job at hand (Fig. 25B). Air pressure in excess of that required can cause premature wear and/or damage to the tool.

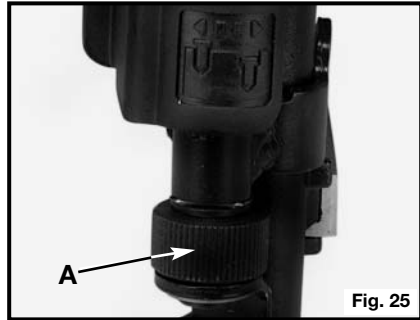

Fig. 25

Nail Size	Pressure
.113 x 2"	80
.113 x 2-3/8"	90
.120 x 3"	110
.131 x 3"	110
.148 x 3"	130
.120 x 3-1/4"	130
.131 x 3-1/4"	130
.131 x 3-1/2"	150

Fig. 25B

A rubber nose cushion (A) Fig. 26 is provided to reduce marring of the work surface. The rubber cushion can be removed, and stored inside knob (B) Fig. 27, to provide increased depth-of-drive for toe-nailing applications.

⚠ WARNING Disconnect tool from air supply before removing or reinstalling rubber cushion.

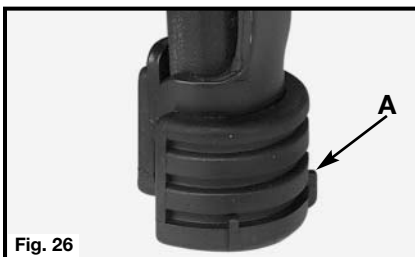

Fig. 26

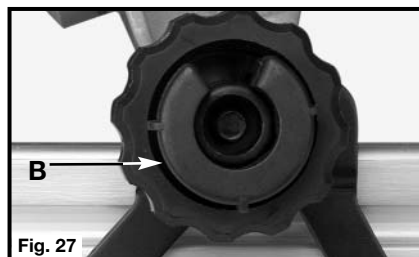
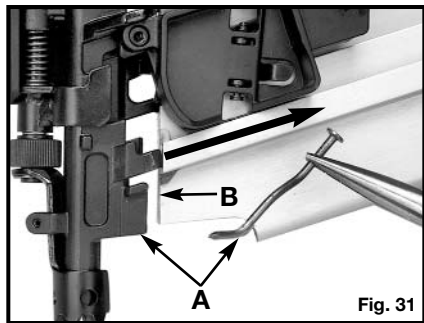
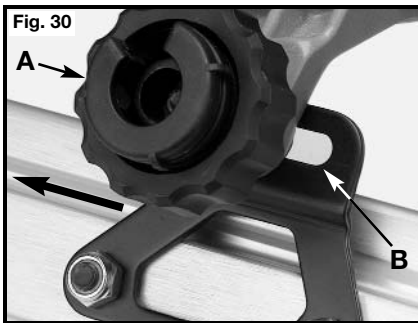
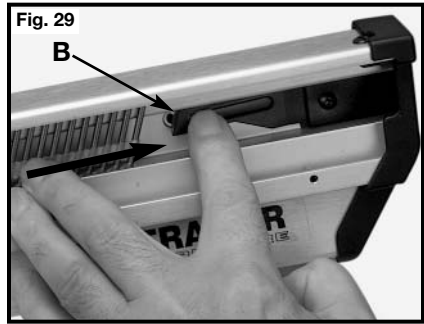
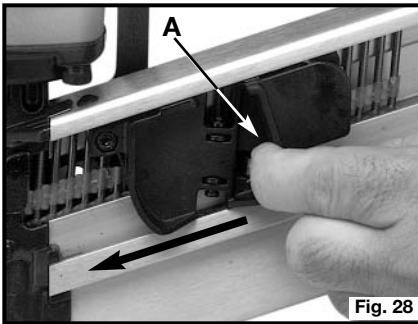

Fig. 27

CLEARING A JAMMED FASTENER

⚠ WARNING Disconnect tool from air supply.

1. Remove any remaining fasteners from the nailer.
 - A. Place finger in recess (A) Fig. 28, and depress lever to release follower mechanism.
 - B. With follower release lever depressed (A) Fig. 28, slide follower all the way to the front of the magazine.
 - C. Depress spring (B) Fig. 29, slide fasteners to the rear, and remove all fasteners from magazine (see Fig. 19).
2. Use a pair of needle nose pliers and/or a flat screwdriver to free bent fastener from back of nosepiece. If fastener cannot be removed as described, it may be necessary to remove the magazine as follows:
 - A. Loosen knob (A) Fig. 30 and move magazine in slotted bracket (B).
 - B. Slide magazine back, off of nosepiece. See (B) Fig. 31.
 - C. After clearing bent fastener (A) Fig. 31, reverse above steps to reassemble.



MAINTENANCE

CLEAN AND INSPECT DAILY

⚠ WARNING Disconnect tool from air supply before cleaning and inspection. Correct all problems before placing the tool back in use.

Wipe tool clean and inspect for wear or damage. Use non-flammable cleaning solutions to wipe exterior of tool only if necessary. DO NOT SOAK tool with cleaning solutions. Such solutions can damage internal parts.

Inspect trigger and safety mechanism to assure system is complete and functional: no loose or missing parts, no binding or sticking parts.

Keep all screws tight. Loose screws can cause personal injury or damage tool.

If tool is used without an in-line oiler: place 5 or 6 drops of Air Tool Oil into the air inlet of the tool at the beginning of each workday.

SERVICE

SERVICE AND REPAIRS

All quality tools will eventually require servicing or replacement of parts due to wear from normal use. For assistance with your tool, visit our website at www.porter-cable.com for a list of service centers or call the Customer Care Department at 1-800-487-8665. All repairs made by our service centers are fully guaranteed against defective material and workmanship. We cannot guarantee repairs made or attempted by others.

Should you have any questions about your tool, feel free to write us at any time. In any communications, please give all information shown on the nameplate of your tool (model number, type, serial number, etc.).

TROUBLESHOOTING GUIDE

▲WARNING Disconnect tool from air supply before performing any Service Procedure.

SYMPTOM	PROBLEMS	SOLUTIONS
1. Air leak near top of tool or in trigger area.	Loose screws. Worn or damaged o-rings or seals.	Tighten screws. Install Overhaul Kit.
2. Tool does nothing or operates sluggishly.	Inadequate air supply. Inadequate lubrication. Worn or damaged o-rings or seals.	Verify adequate air supply. Put 5 or 6 drops of oil into air inlet. Install Overhaul Kit.
3. Air leak near bottom of tool.	Loose screws. Worn or damaged o-rings or bumper.	Tighten screws. Install Overhaul Kit.
4. Tool jams frequently.	Incorrect fasteners. Damaged fasteners. Magazine or nose screws loose. Magazine is dirty. Driver is worn or damaged.	Verify approved fasteners of correct size. Replace w/undamaged fasteners. Tighten screws. Clean magazine. Install "DRIVER" Maintenance Kit.
5. Other.		Contact a Porter-Cable Service Facility.

ACCESSORIES

A complete line of accessories is available from your Porter-Cable • Delta Supplier, Porter-Cable • Delta Factory Service Centers, and Porter-Cable Authorized Service Stations. Please visit our Web Site www.porter-cable.com for a catalog or for the name of your nearest supplier.

▲ WARNING Since accessories, other than those offered by Porter-Cable • Delta, have not been tested with this product, use of such accessories could be hazardous. For safest operation, only Porter-Cable • Delta recommended accessories should be used with this product.

LIMITED WARRANTY

PORTER-CABLE LIMITED ONE YEAR WARRANTY

Porter-Cable warrants its nailing and stapling tools for a period of one year from the date of original purchase. We will repair or replace at our option, any part or parts of the product and accessories covered under this warranty which, after examination, proves to be defective in workmanship or material during the warranty period. For repair or replacement return the complete tool or accessory, transportation prepaid, to your nearest Porter-Cable Service Center or Authorized Service Station. Proof of purchase may be required. This warranty does not apply to O-rings and Driver Blades or to repair or replacement required due to misuse, abuse, normal wear and tear or repairs attempted or made by other than our Service Centers or Authorized Service Stations.

ANY IMPLIED WARRANTY, INCLUDING THE IMPLIED WARRANTIES OF MERCHANTABILITY AND FITNESS FOR A PARTICULAR PURPOSE, WILL LAST ONLY FOR ONE (1) YEAR FROM THE DATE OF PURCHASE.

To obtain information on warranty performance please write to: PORTER-CABLE CORPORATION, 4825 Highway 45 North, Jackson, Tennessee 38305; Attention: Product Service. THE FOREGOING OBLIGATION IS PORTER-CABLE'S SOLE LIABILITY UNDER THIS OR ANY IMPLIED WARRANTY AND UNDER NO CIRCUMSTANCES SHALL PORTER-CABLE BE LIABLE FOR ANY INCIDENTAL OR CONSEQUENTIAL DAMAGES. Some states do not allow limitations on how long an implied warranty lasts or the exclusion or limitation of incidental or consequential damages, so the above limitation or exclusion may not apply to you.

This warranty gives you specific legal rights and you may also have other legal rights which vary from state to state.

PORTER-CABLE • DELTA SERVICE CENTERS (CENTROS DE SERVICIO DE PORTER-CABLE • DELTA) (CENTRE DE SERVICE PORTER-CABLE • DELTA)

**Parts and Repair Service for Porter-Cable • Delta Power Tools are Available at These Locations
(Obtenga Refacción de Partes o Servicio para su Herramienta en los Sigüientes Centros de Porter-Cable • Delta)
(Locations où vous trouverez les pièces de rechange nécessaires ainsi qu'un service d'entretien)**

ARIZONA

Tempe 85282 (Phoenix)
2400 West Southern Avenue
Suite 105
Phone: (602) 437-1200
Fax: (602) 437-2200

CALIFORNIA

Ontario 91761 (Los Angeles)
3949A East Guasti Road
Phone: (909) 390-5555
Fax: (909) 390-5554

San Diego 92111
7638 Clairemont Blvd.
Phone: (858) 277-9595
Fax: (858) 277-9696

San Leandro 94577 (Oakland)
3039 Teagarden Street
Phone: (510) 357-9762
Fax: (510) 357-7939

COLORADO

Arvada 80003 (Denver)
8175 Sheridan Blvd., Unit S
Phone: (303) 487-1809
Fax: (303) 487-1868

FLORIDA

Davie 33314 (Miami)
4343 South State Rd. 7 (441)
Unit #107
Phone: (954) 321-6635
Fax: (954) 321-6638

Tampa 33609
4538 W. Kennedy Boulevard
Phone: (813) 877-9585
Fax: (813) 289-7948

GEORGIA

Forest Park 30297 (Atlanta)
5442 Frontage Road,
Suite 112
Phone: (404) 608-0006
Fax: (404) 608-1123

ILLINOIS

Addison 60101 (Chicago)
400 South Rohwing Rd.
Phone: (630) 424-8805
Fax: (630) 424-8895

Woodridge 60517 (Chicago)
2033 West 75th Street
Phone: (630) 910-9200
Fax: (630) 910-0360

MARYLAND

Elkridge 21075 (Baltimore)
7397-102 Washington Blvd.
Phone: (410) 799-9394
Fax: (410) 799-9398

MASSACHUSETTS

Franklin 02038 (Boston)
Franklin Industrial Park
101E Constitution Blvd.
Phone: (508) 520-9802
Fax: (508) 528-8089

MICHIGAN

Madison Heights 48071 (Detroit)
30475 Stephenson Highway
Phone: (248) 597-5000
Fax: (248) 597-5004

MINNESOTA

Minneapolis 55429
5522 Lakeland Avenue North
Phone: (763) 561-9080
Fax: (763) 561-0653

MISSOURI

North Kansas City 64116
1141 Swift Avenue
Phone: (816) 221-2070
Fax: (816) 221-2897

St. Louis 63119

7574 Watson Road
Phone: (314) 968-8950
Fax: (314) 968-2790

NEW YORK

Flushing 11365-1595 (N.Y.C.)
175-25 Horace Harding Expwy.
Phone: (718) 225-2040
Fax: (718) 423-9619

NORTH CAROLINA

Charlotte 28270
9129 Monroe Road, Suite 115
Phone: (704) 841-1176
Fax: (704) 708-4625

OHIO

Columbus 43214
4560 Indianola Avenue
Phone: (614) 263-0929
Fax: (614) 263-1238

Cleveland 44125
8001 Sweet Valley Drive
Unit #19
Phone: (216) 447-9030
Fax: (216) 447-3097

OREGON

Portland 97230
4916 NE 122 nd Ave.
Phone: (503) 252-0107
Fax: (503) 252-2123

PENNSYLVANIA

Willow Grove 19090 (Philadelphia)
520 North York Road
Phone: (215) 658-1430
Fax: (215) 658-1433

TEXAS

Carrollton 75006 (Dallas)
1300 Interstate 35 N, Suite 112
Phone: (972) 446-2996
Fax: (972) 446-8157

HOUSTON

Houston 77043
4321 Sam Houston Parkway, West
Suite 180
Phone: (713) 983-9910
Fax: (713) 983-6645

WASHINGTON

Auburn 98001 (Seattle)
3320 West Valley HWY, North
Building D, Suite 111
Phone: (253) 333-8353
Fax: (253) 333-9613

Authorized Service Stations are located in many large cities. Telephone **800-487-8665** or **731-541-6042** for assistance locating one. Parts and accessories for Porter-Cable • Delta products should be obtained by contacting any Porter-Cable • Delta Distributor, Authorized Service Center, or Porter-Cable • Delta Factory Service Center. If you do not have access to any of these, call **888-848-5175** and you will be directed to the nearest Porter-Cable • Delta Factory Service Center. Las Estaciones de Servicio Autorizadas están ubicadas en muchas grandes ciudades. Llame al **800-487-8665** ó al **731-541-6042** para obtener asistencia a fin de localizar una. Las piezas y los accesorios para los productos Porter-Cable • Delta deben obtenerse poniéndose en contacto con cualquier distribuidor Porter-Cable • Delta, Centro de Servicio Autorizado o Centro de Servicio de Fábrica Porter-Cable • Delta. Si no tiene acceso a ninguna de estas opciones, llame al **888-848-5175** y le dirijirán al Centro de Servicio de Fábrica Porter-Cable • Delta más cercano. Des centres de service agréés sont situés dans beaucoup de grandes villes. Appelez au **800-487-8665** ou au **731-541-6042** pour obtenir de l'aide pour en repérer un. Pour obtenir des pièces et accessoires pour les produits Porter-Cable • Delta, s'adresser à tout distributeur Porter-Cable • Delta, centre de service agréé ou centre de service d'usine Porter-Cable • Delta. Si vous n'avez accès à aucun de ces centres, appeler le **888-848-5175** et on vous dirigera vers le centre de service d'usine Porter-Cable • Delta le plus proche.

CANADIAN PORTER-CABLE • DELTA SERVICE CENTERS

ALBERTA

Bay 6, 2520-23rd St. N.E.
Calgary, Alberta
T2E 8L2
Phone: (403) 735-6166
Fax: (403) 735-6144

BRITISH COLUMBIA

8520 Baxter Place
Burnaby, B.C.
V5A 4T8
Phone: (604) 420-0102
Fax: (604) 420-3522

MANITOBA

1699 Dublin Avenue
Winnipeg, Manitoba
R3H 0H2
Phone: (204) 633-9259
Fax: (204) 632-1976

ONTARIO

505 Southgate Drive
Guelph, Ontario
N1H 6M7
Phone: (519) 767-4132
Fax: (519) 767-4131

QUÉBEC

1515 Ave.
St-Jean Baptiste, Suite 160
Québec, P.Q.
G2E 5E2
Phone: (418) 877-7112
Fax: (418) 877-7123

1447, Beginn

St-Laurent, (Mtl), P.Q.

H4R 1V8

Phone: (514) 336-8772

Fax: (514) 336-3505

The following are trademarks of PORTER-CABLE • DELTA (Las siguientes son marcas registradas de PORTER-CABLE • DELTA S.A.) (Les marques suivantes sont des marques de fabricant de la PORTER-CABLE • DELTA): Auto-Set®, BAMMER®, B.O.S.S.®, Builder's Saw®, Contractor's Saw®, Contractor's Saw II™, Delta™, DELTACRAFT™, DELTAGRAM™, Delta Series 2000™, DURATRONIC™, Emc²™, FLEX™, Flying Chips™, FRAME SAW®, Grip Vac™, Homecraft™, INNOVATION THAT WORKS™, Jet-Lock™, JETSTREAM™, 'kickstand', LASERLOC™, MICRO-SET™, Micro-Set®, MIDI LATHE™, MORTEN™, NETWORK™, OMNIJIG™, POCKET CUTTER™, PORTA-BAND™, PORTA-PLANE™, PORTER-CABLE™&(design), PORTER-CABLE™ PROFESSIONAL POWER TOOLS, PORTER-CABLE REDEFINING PERFORMANCE™, Posi-Matic™, Q-3®&(design), QUICKSAND®&(design), QUICKSET™, QUICKSET II®, QUICKSET PLUS™, RIPTIDE™&(design), SAFE GUARD II®, SAFE-LOC™, Sanding Center™, SANDTRAP®&(design), SAW BOSS™, Sawbuck™, Sidekick™, SPEED-BLOC®, SPEEDMATIC™, SPEEDTRONIC™, STAIR EASE™, The American Woodshop®&(design), The Lumber Company®&(design), THE PROFESSIONAL EDGE™, THE PROFESSIONAL SELECT™, THIN-LINE™, TIGER®, TIGER CUB™, TIGER SAW®, TORQBUSTER™, TORQ-BUSTER®, TRU-MATCH™, TWIN-LITE™, UNIGUARD™, Unifence®, UNIFEEDER™, Unihead™, Uniplane™, Uniprip™, Unisaw®, Univise®, Versa-Feeder®, VERSA-PLANE™, WHISPER SERIES™, WOODWORKER'S CHOICE™.

Trademarks noted with ™ and ® are registered in the United States Patent and Trademark Office and may also be registered in other countries. Las Marcas Registradas con el signo de ™ y ® son registradas por la Oficina de Registros y Patentes de los Estados Unidos y también pueden estar registradas en otros países. Marques déposées, indiquées par la lettre ™ et ®, sont déposées au Bureau des brevets d'invention et marques déposées aux Etats-Unis et pourraient être déposées aux autres pays...