

OPERATION AND PARTS MANUAL



WHITEMAN **HDA-SERIES** **WALK-BEHIND TROWEL**

Revision #9 (07/02/10)

To find the latest revision of this
publication, visit our website at:
www.multiquip.com



THIS MANUAL MUST ACCOMPANY THE EQUIPMENT AT ALL TIMES.

P/N 20920



WARNING



CALIFORNIA — Proposition 65 Warning

Engine exhaust and some of its constituents, and some dust created by power sanding, sawing, grinding, drilling and other construction activities contains chemicals known to the State of California to cause cancer, birth defects and other reproductive harm.

Some examples of these chemicals are:

- Lead from lead-based paints.
- Crystalline silica from bricks.
- Cement and other masonry products.
- Arsenic and chromium from chemically treated lumber.

Your risk from these exposures varies, depending on how often you do this type of work. To reduce your exposure to these chemicals: **ALWAYS** work in a well ventilated area, and work with approved safety equipment, such as dust masks that are specially designed to filter out microscopic particles.

TABLE OF CONTENTS

HDA-Series Walk-Behind Trowel

Proposition 65 Warning	2
Table Of Contents	4
Parts Ordering Procedures	5
Training Checklist	6
Daily Pre-Operation Checklist	7
Safety Message Alert Symbols	8-9
Rules For Safe Operation	10-11
Operation And Safety Decals	12
Specifications (Trowel)	13
Specifications (Engines)	14
General Information	15
Controls And Components	16-17
Basic Engine	18
Assembly And Installation	19-21
Pre-Inspection	22-23
Initial Start-Up	24-25
Operation	26-27
Options	28-29
Maintenance	30-34
Troubleshooting (Trowel)	35-36
Troubleshooting (Engine)	37
Explanation Of Codes	38
Suggested Spare Parts	39

Component Drawings

Nameplate And Decals	40-41
Standard Handle Assembly (Old Style)	42-43
Standard Handle Assembly (New Style)	44-45
Quick-Pitch™ Handle Assembly (Old Style) ..	46-49
Quick-Pitch™ Handle Assembly (New Style) ..	50-51
4-Blade Spider Assembly	52-53
Gearbox & Engine Mounts Assembly	54-55
Engine, 11 Hp Honda Assembly	56-57
Engine, 13 Hp Honda Assembly	58-59
Guard Ring Assembly	60-61
Stabilizer Ring Assembly	62-63
Blades & Arm Adj. Fixture Assembly (Options)	64-65
Lifting Bail Assembly (Option)	66-67

Honda GX340K1QA2 Engine

Air Cleaner Assembly	68-69
Camshaft Assembly	70-71
Piston Assembly	72-73
Crankcase Cover Assembly	74-75
Crankshaft Assembly	76-77
Cylinder Barrel Assembly	78-79
Cylinder Head Assembly	80-81
Fan Cover Assembly	82-83
Flywheel Assembly	84-85
Fuel Tank Assembly	86-87
Ignition Coil Assembly	88-89
Carburetor Assembly	90-93
Muffler Assembly	94-95
Recoil Starter Assembly	96-97
Control Assembly	98-99
Labels Assembly	100-101

Honda GX390K1QA2 Engine

Air Cleaner Assembly	102-103
Camshaft Assembly	104-105
Piston Assembly	106-107
Crankcase Cover Assembly	108-109
Crankshaft Assembly	110-111
Cylinder Barrel Assembly	112-113
Cylinder Head Assembly	114-115
Fan Cover Assembly	116-117
Flywheel Assembly	118-119
Fuel Tank Assembly	120-121
Ignition Coil Assembly	122-123
Carburetor Assembly	124-125
Muffler Assembly	126-127
Recoil Starter Assembly	128-129
Control Assembly	130-131
Gasket Kit Assembly	132-133
Labels Assembly	134-135
Terms And Conditions Of Sale — Parts	136

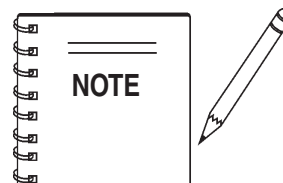

**Specification and part number
are subject to change without
notice.**

PARTS ORDERING PROCEDURES

Ordering parts has never been easier! Choose from three easy options:

Effective:
January 1st, 2006

www.multiquip.com



Order via Internet (Dealers Only):

Order parts on-line using Multiquip's SmartEquip website!

- View Parts Diagrams
- Order Parts
- Print Specification Information



If you have an MQ Account, to obtain a Username and Password, E-mail us at: parts@multiquip.com.

To obtain an MQ Account, contact your District Sales Manager for more information.

Goto www.multiquip.com and click on

Order Parts to log in and save!

Use the **internet** and qualify for a **5% Discount** on *Standard orders* for all orders which include complete part numbers.*

Note: Discounts Are Subject To Change



Order via Fax (Dealers Only):

All customers are welcome to order parts via Fax.

Domestic (US) Customers dial:

1-800-6-PARTS-7 (800-672-7877)

Fax your order in and qualify for a **2% Discount** on *Standard orders* for all orders which include complete part numbers.*

Note: Discounts Are Subject To Change



Order via Phone: Domestic (US) Dealers Call:

1-800-427-1244

Non-Dealer Customers:

Contact your local Multiquip Dealer for parts or call 800-427-1244 for help in locating a dealer near you.



International Customers should contact their local Multiquip Representatives for Parts Ordering information.

When ordering parts, please supply:

- | | |
|---|--|
| <input type="checkbox"/> Dealer Account Number | <input type="checkbox"/> Specify Preferred Method of Shipment: |
| <input type="checkbox"/> Dealer Name and Address | <input checked="" type="checkbox"/> UPS/Fed Ex <input checked="" type="checkbox"/> DHL |
| <input type="checkbox"/> Shipping Address (if different than billing address) | <input type="checkbox"/> Priority One <input checked="" type="checkbox"/> Truck |
| <input type="checkbox"/> Return Fax Number | <input type="checkbox"/> Ground |
| <input type="checkbox"/> Applicable Model Number | <input type="checkbox"/> Next Day |
| <input type="checkbox"/> Quantity, Part Number and Description of Each Part | <input type="checkbox"/> Second/Third Day |

NOTICE

All orders are treated as *Standard Orders* and will ship the same day if received prior to 3PM PST.

WE ACCEPT ALL MAJOR CREDIT CARDS!



TRAINING CHECKLIST

TRAINING CHECKLIST

This checklist will lists some of the minimum requirements for machine maintenance and operation. Please feel free to detach it and make copies. Use this checklist whenever a new operator is to be trained or it can be used as a review for more experienced operator's.

TRAINING CHECKLIST			
NO.	DESCRIPTION	OK?	DATE
1	Read Operator's Manual completely.		
2	Machine layout, location of components, checking of engine and gearbox fluid level.		
3	Fuel system, refueling procedure.		
4	Operation of controls (machine not running).		
5	Safety controls, safety stop switch operation.		
6	Emergency stop procedures.		
7	Startup of machine.		
8	Maneuvering.		
9	Pitching.		
10	Concrete finishing techniques.		
11	Shutdown of machine.		
12	Lifting of machine.		
13	Machine transport and storage.		

Operator _____ Trainee _____

COMMENTS:

DAILY PRE-OPERATION CHECKLIST

DAILY PRE-OPERATION CHECKLIST

DAILY PRE-OPERATION CHECKLIST	
1	Engine Oil Level.
2	Gearbox Fluid Level.
3	Condition of Blades.
4	Blade Pitch Operation.
5	Safety Stop Switch Operation.
6	V-Belt Clutch Operation.

COMMENTS:

SAFETY MESSAGE ALERT SYMBOLS

FOR YOUR SAFETY AND THE SAFETY OF OTHERS!

Safety precautions should be followed at all times when operating this equipment. Failure to read and understand the Safety Messages and Operating Instructions could result in injury to yourself and others.

NOTE

This Owner's Manual has been developed to provide complete instructions for the safe and efficient operation of the MultiQuip HDA-SERIES WALK-BEHIND TROWEL. For engine maintenance information, please refer to the engine manufacturers instructions for data relative to its safe operation.

Before using this WALK-BEHIND TROWEL, ensure that the operating individual has read and understands all instructions in this manual.

SAFETY MESSAGE ALERT SYMBOLS

The three (3) Safety Messages shown below will inform you about potential hazards that could injure you or others. The Safety Messages specifically address the level of exposure to the operator, and are preceded by one of three words: **DANGER**, **WARNING**, or **CAUTION**.



DANGER: You **WILL** be **KILLED** or **SERIOUSLY** injured if you **DO NOT** follow directions.



WARNING: You **CAN** be **KILLED** or **SERIOUSLY** injured if you **DO NOT** follow directions.



CAUTION: You **CAN** be injured if you **DO NOT** follow directions.

Potential hazards associated with trowel operation will be referenced with "**Hazard Symbols**" which appear throughout this manual, and will be referenced in conjunction with Safety "**Message Alert Symbols**".

HAZARD SYMBOLS



Lethal Exhaust Gases



Engine exhaust gases contain poisonous carbon monoxide. This gas is colorless and odorless, and can cause death if inhaled. **NEVER** operate this equipment in a confined area or enclosed structure that does not provide ample free flow air.



Explosive Fuel



Gasoline is extremely flammable, and its vapors can cause an explosion if ignited. **DO NOT** start the engine near spilled fuel or combustible fluids. **DO NOT** fill the fuel tank while the engine is running or hot. **DO NOT** overfill tank, since spilled fuel could ignite if it comes into contact with hot engine parts or sparks from the ignition system. Store fuel in approved containers, in well-ventilated areas and away from sparks and flames. **NEVER** use fuel as a cleaning agent.



Burn Hazards



Engine components can generate extreme heat. To prevent burns, **DO NOT** touch these areas while the engine is running or immediately after operations. **NEVER** operate the engine with heat shields or heat guards removed.



Rotating Parts



NEVER operate equipment with covers, or guards removed. Keep **fingers, hands, hair** and **clothing** away from all moving parts to prevent injury.

SAFETY MESSAGE ALERT SYMBOLS



Accidental Starting



OFF **ALWAYS** place the engine ON/OFF switch in the **OFF** position, when the trowel is not in use.



Respiratory Hazard



ALWAYS wear approved respiratory protection.



Over Speed Conditions



NEVER tamper with the factory settings of the engine governor or settings. Personal injury and damage to the engine or equipment can result if operating in speed ranges above maximum allowable.



Sight and Hearing hazard



ALWAYS wear approved eye and hearing protection.

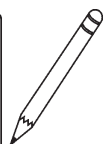
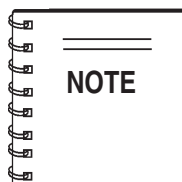

This **walk-behind trowel**, other property, or the surrounding environment could be damaged if you do not follow instructions.



Equipment Damage Messages

Other important messages are provided throughout this manual to help prevent damage to your trowel, other property, or the surrounding environment.

RULES FOR SAFE OPERATION

RULES FOR SAFE OPERATION

CAUTION:



Failure to follow instructions in this manual may lead to serious injury or even death! This equipment is to be operated by trained and qualified personnel only! This equipment is for industrial use only.

The following safety guidelines should always be used when operating the **HDA-SERIES** walk-behind trowel.

SAFETY

- **DO NOT** operate or service this equipment before reading this entire manual.



- This equipment should not be operated by persons under 18 years of age.
- **NEVER** operate the trowel without proper protective clothing, shatterproof glasses, steel-toed boots and other protective devices required by the job.

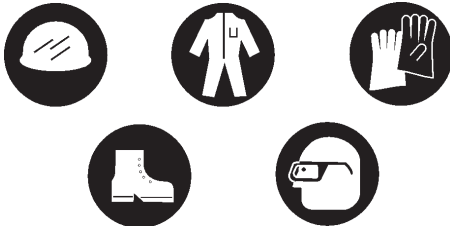

- **NEVER** operate this equipment when not feeling well due to fatigue, illness or taking medicine.



- **NEVER** operate the trowel under the influence of drugs or alcohol.



- **NEVER** use accessories or attachments, which are not recommended by Multiquip for this equipment. Damage to the equipment and/or injury to user may result.
- Manufacturer does not assume responsibility for any accident due to equipment modifications.
- Whenever necessary, replace nameplate, operation and safety decals when they become difficult read.
- **ALWAYS** check the trowel for loosened threads or bolts before starting.

- **NEVER** touch the hot exhaust manifold, muffler or cylinder. Allow these parts to cool before servicing the trowel.



- **High Temperatures** – Allow the engine to cool before adding fuel or performing service and maintenance functions. Contact with **hot!** components can cause serious burns.

- The engine of this trowel requires an adequate free flow of cooling air. **NEVER** operate the trowel (except electric models)

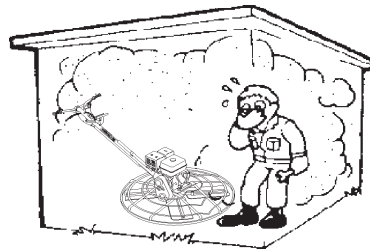

in any enclosed or narrow area where free flow of the air is restricted. If the air flow is restricted it will cause serious damage to the trowel's engine and may cause injury to people. Remember the trowel's engine gives off **DEADLY** carbon monoxide gas.

- **ALWAYS** refuel in a well-ventilated area, away from sparks and open flames.

- **ALWAYS** use extreme caution when working with **flammable** liquids. When refueling, **stop the engine** and allow it to cool.

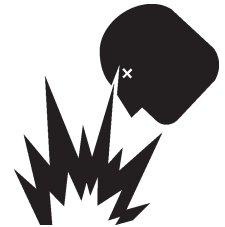

- **NEVER** smoke around or near the machine. Fire or explosion could result from **fuel vapors**, or if fuel is spilled on a **hot!** engine.



- **NEVER** operate the trowel in an explosive atmosphere or near combustible materials. An explosion or fire could result causing severe **bodily harm or even death**.

- Topping-off to filler port is dangerous, as it tends to spill fuel.

RULES FOR SAFE OPERATION

- **DO NOT** operate this trowel unless all guards and safety devices are attached and in place. See pages 16 and 17.
- **ALWAYS** use proper lifting techniques when moving the trowel. See page 24.
- **ALWAYS** check to make sure that the operating area is clear before starting the engine.
- **ALWAYS** test the safety **stop switch** devices before operating the trowel.
- **NEVER** place your **feet** or **hands** inside the guard rings while starting or operating this equipment.
- **AVOID** wearing jewelry or loose fitting clothing that may snag on the controls or moving parts, this can cause a serious injury.
- **ALWAYS** keep clear of **rotating** or **moving parts** while operating the trowel.
- **NEVER** leave the machine **unattended** while running.
- **Moving Parts** – Shut down the engine before performing service or maintenance functions. Contact with moving parts can cause serious injury.

Maintenance Safety

- Disconnect the spark plug wires before attempting any type of service.
- Securely support any machine components that must be raised.
- **NEVER** lubricate components or attempt service on a running machine.
- **DO NOT** use food or plastic containers to dispose of hazardous waste.
- **DO NOT** pour **waste**, **oil** or **fuel** directly onto the ground, down a drain or into any water source.

- Keep the trowel in proper running condition.
- Make sure that there is no buildup of concrete, grease, oil or debris on the trowel.
- Fix damage to the trowel immediately and always replace broken parts.
- Dispose of hazardous waste properly. Examples of potentially hazardous waste are used **motor oil**, **fuel** and **fuel filters**.
- **High Temperatures** – Allow the machine and engine to **cool** before adding fuel or performing service and maintenance functions. Contact with **hot!** components can cause serious burns.

CAUTION

EMERGENCIES

- **ALWAYS** know the location of the nearest **fire extinguisher**.

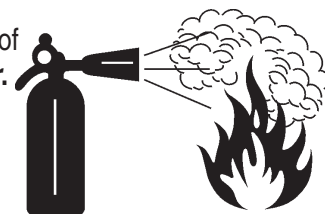

- **ALWAYS** know the location of the nearest and **first aid kit**.



- In emergencies **always** know the location of the nearest phone or **keep a phone on the job site**. Also know the phone numbers of the nearest **ambulance**, **doctor** and **fire department**. This information will be invaluable in the case of an emergency.



OPERATION AND SAFETY DECALS

OPERATION AND SAFETY DECALS

The HDA-SERIES walk-behind trowel is equipped with a number of operation and safety decals. These decals are provided for operator safety and maintenance information. Should any of these decals become unreadable, replacements can be obtained from your dealer.

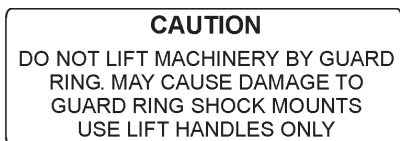

P/N 1261



P/N 1940



P/N 20526



P/N 20527



P/N 1736

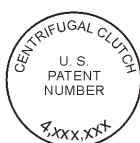

P/N 2635



P/N 2423

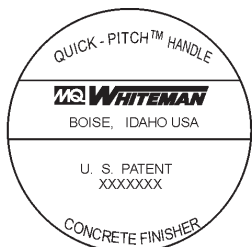

P/N 1758



P/N 12405



P/N 1492



P/N 1848



P/N 1735



P/N 2938



P/N1499

	Symbol indicates that it is mandatory to wear safety glasses, safety helmet and ear protection. P/N 11247 (Part of decal kit 12620)		CONTACT MULTIQUIP SERVICE DEPT.
	Symbol indicates that it is mandatory to wear gloves. P/N 11247 (Part of decal kit 12620)		Symbol indicates that it is mandatory to wear safety shoes, with extra protection (steel toed). P/N 11247 (Part of decal kit 12620)
	Radiating heat symbol. Symbol indicates equipment is hot. P/N 11246 (Part of decal kit 12620)		This is the symbol for belt drive. P/N 11246 (Part of decal kit 12620)
	Symbol for examining or checking of the machine. Mostly used for maintenance. Check lubrication oil in gearbox. P/N 11246 (Part of decal kit 12620)		This is the symbol for gear drive. P/N 11246 (Part of decal kit 12620)

Figure 1. HDA-SERIES trowel Decals

SPECIFICATIONS (TROWEL)

SPECIFICATIONS (TROWEL)

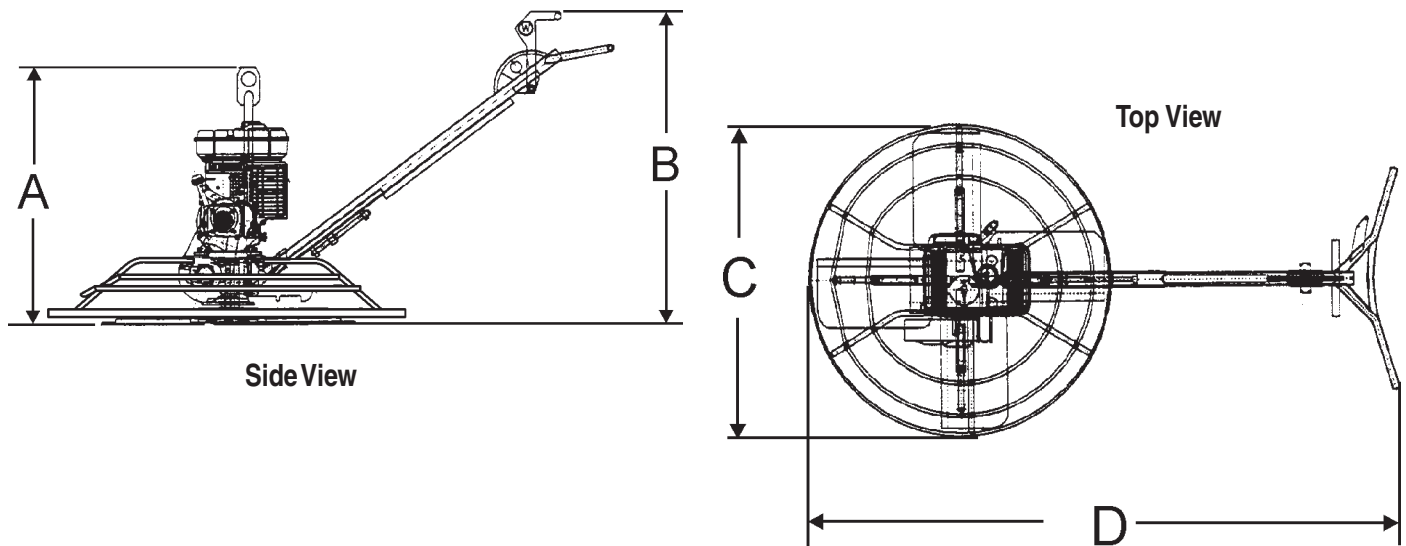

Figure 2. HDA-SERIES Trowel Dimensions

Table 1. HDA-Series Trowel Specifications	
A- Height (Lifting Hook)	34.5 in (876.2 mm)
B- Height Engagement Lever)	41.1 in (1,044.2 mm)
C-Width	48.0 (1,168.4 mm)
D-Length	75.2 (1,910.1 mm)
Weight – Operating	230 lbs./105 Kg.
Sound Pressure	97 db
Vibration	2.5g (24.5 m/s ²)
Ring Diameter	46 in (117 cm)
Number of Blades	4
Blade Tip Speed – FPM (m/s)	1,478 fpm (7.5 m/s)
Rotor – RPM (Gasoline)	60 to 125
Path Width – in. (cm)	48 (233)

NOTE:

1. Sound pressure is a weighted measure. Measured at the operators ear position while the walk-behind trowel is operating at full throttle on concrete in a manner most often experienced in “*normal*” circumstances. Sound pressure may vary depending upon the condition of the concrete. Hearing protection is always recommended.
2. The vibration level indicated is the maximum RMS (Root Mean Square) value obtained at the handle grip while operating the walk-behind trowel on curing concrete in a manner most often experienced in “*normal*” circumstances. Values were obtained from all three axes of motion. The values shown represent the maximum RMS value from these measurements.

SPECIFICATIONS (ENGINES)

SPECIFICATIONS (ENGINES)

Table 2. Specifications (Engine)			
Engine	Model	HONDA GX340K1QA2	HONDA GX390K1QA2
	Type	Air-cooled 4 stroke, Single Cylinder, OHV, Horizontal Shaft Gasoline Engine	Air-cooled 4 stroke, Single Cylinder, OHV, Horizontal Shaft Gasoline Engine
	Bore X Stroke	3.2 in. X 2.5 in. (82 mm x 64 mm)	3.5 in. X 2.5 in. (88 mm x 64 mm)
	Displacement	20.6 cu. in. 337 cc	23.7 cu. in. 389 cc
	Max Output	11.0 H.P./3600 R.P.M.	13.0 H.P./3600 R.P.M.
	Fuel Tank Capacity	Approx. 1.72 U.S. Gallons (6.5 Liters)	Approx. 1.72 U.S. Gallons (6.5 Liters)
	Fuel	Unleaded Automobile Gasoline	Unleaded Automobile Gasoline
	Lube Oil Capacity	1.16 US Qt. (1.1 Liters)	1.16 US Qt. (1.1 Liters)
	Speed Control Method	Centrifugal Fly-weight Type	Centrifugal Fly-weight Type
	Starting Method	Recoil Start	Recoil Start
Dimension (L x W x H)	15.0 x 17.7 X 17.4 in. (380 X 450 X 443 mm)	15.0 x 17.7 X 17.4 in. (380 X 450 X 443 mm)	
Dry Net Weight	68.4 lbs (31 Kg.)	68.4 lbs (31 Kg.)	

GENERAL INFORMATION

HDA-SERIES Walk-Behind Trowel Familiarization

This walk-behind trowel is designed for the **floating** and **finishing** of concrete slabs.

Take a walk around the trowel. Take notice of all the major components (see pages 16 and 17) like the engine, blades, quick pitch control, air cleaner, centrifugal stop switch etc. Check that there is always oil in the engine.

Read all the safety instructions carefully. Safety instructions will be found throughout this manual and on the trowel. Keep all safety information in good, readable condition. Operators should be well trained on the operation and maintenance of the trowel.

Before using your trowel, test it on a flat watered down section of finished concrete that is free of any debris and other objects.

This trial test run will increase your confidence in using the trowel and at the same time it will familiarize you with the trowel's controls. In addition you will understand how the trowel handles under actual conditions.

Engines

This trowel is available with an 11 HP or 13 HP gasoline engine. Refer to the engine owner's manual for instructions regarding the operation and maintenance of your engine. Please contact your nearest Multiquip Dealer for a replacement should the original manual disappear or otherwise become unusable.

Drive System

Power is transferred from the engine to the gearbox input shaft via a V-belt or pulley drive system. The pulley engages using a centrifugal clutch.

Gearbox

The **gearbox** is located beneath the engine and transfers power to the **rotor** or **spider** assembly. The gearbox controls the rotational speed of the trowel and is equipped with two shafts (input and output).

Spider

The vertical output shaft of the gearbox connects to a cast hub called the **spider**. The spider has 4 arms that extend outward that are used for attachment of blades or other accessories. Remember as the gearbox output shaft rotates so does the spider assembly.

Blades

The blades of the trowel finish the concrete as they are rotated around the surface. Blades are classified as **combination** (8 inches wide), **float** (10 or 8 inches wide), and **finish** (6 inches wide). This trowel comes equipped with either **three** or four **blades** per rotor equally spaced in a radial pattern and attached to vertical rotating shaft by means of a **spider assembly**.

Centrifugal Stop Switch

In the event of a trowel runaway condition (operator releases the handle), a **centrifugal stop switch** or **manual clutch** depending on which trowel you have, will stop the engine and bring the trowel to a halt.

CAUTION

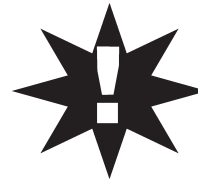

NEVER attempt to **lift** the trowel by yourself. **ALWAYS** get the assistance of another person to help lift the trowel or use a crane or lifting device to move the trowel.

Moving the HDA-SERIES Walk-Behind Trowel

This walk-behind trowel is designed to be moved and handled in several ways. The easiest way to lift the trowel is to use the **auxiliary lifting tube** that is attached to the main handle. See page 24, Figure 20. When using the auxiliary tube, always use **two persons** to lift the trowel.

Some models have a **lifting bail** (option) installed. A strap or chain can be attached to the lifting bail, allowing a forklift or crane to lift the trowel up onto a slab of concrete. Use a lifting device of adequate lifting capacity to lift the trowel.

Training

For proper training, please use the "**TRAINING CHECKLIST**" located in the front of this manual (Page 6). This checklist will provide an outline for an experienced operator to provide training to a new operator.

CONTROLS AND COMPONENTS

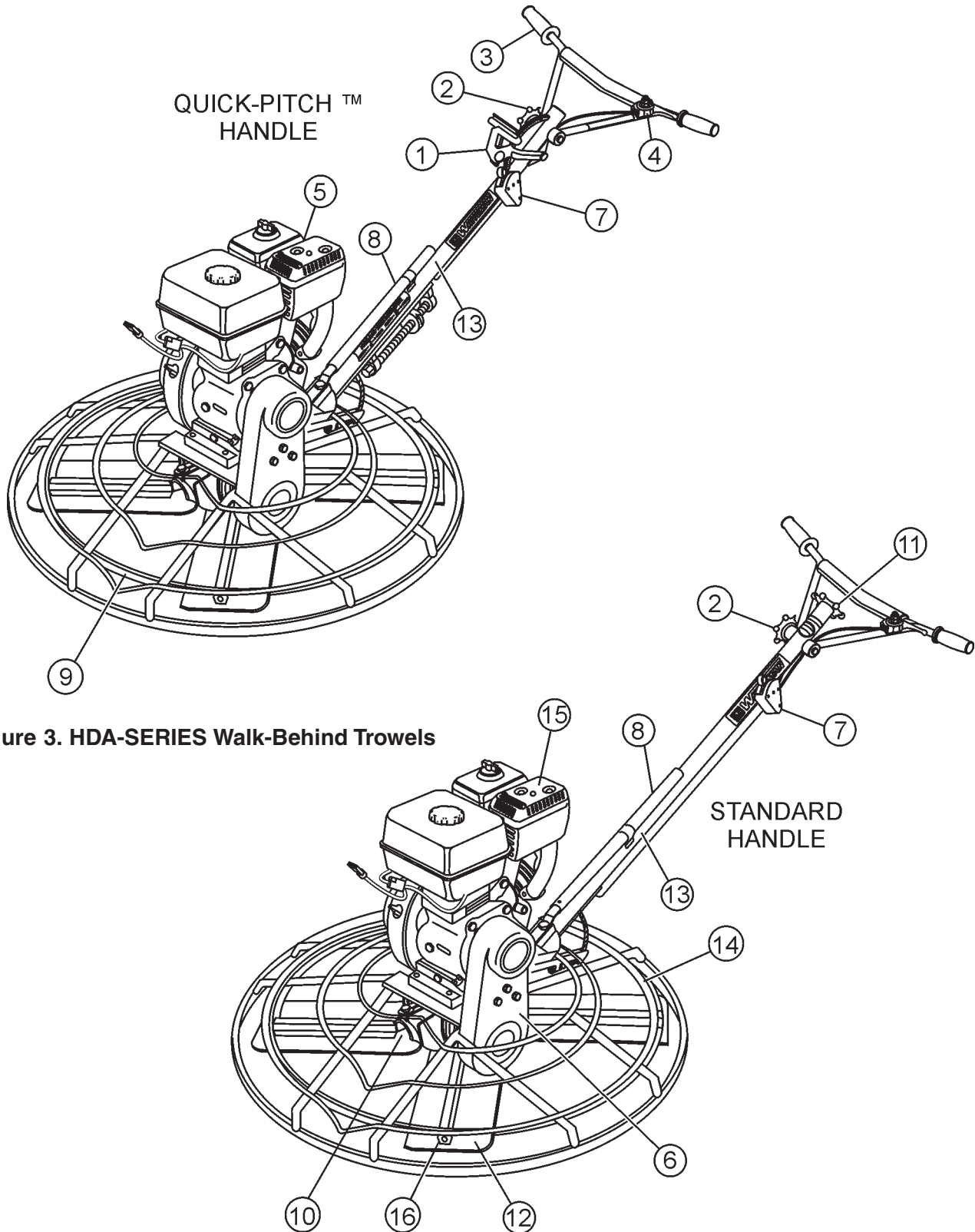

Figure 3. HDA-SERIES Walk-Behind Trowels

CONTROLS AND COMPONENTS

Figure 3 shows the location of the basic controls or components, for the HDA-SERIES trowel. Listed below is a brief explanation of each control or component

1. **Quick-Pitch™ Control Handle** – To adjust the pitch of the blades, grasp the handle then squeeze and either move the handle forward or backward to achieve the desired blade pitch.
2. **Handlebar Adjuster** – Change the angle/height of the handle bars by loosening star wheel, adjust handlebars to desired location, tighten *starwheel* firmly to hold handlebars in that position.
3. **Hand Grip/Handle Bar** – When operating the trowel, place both hands on each grip to maneuver the trowel. Replace hand grips when they become worn or damaged.
4. **Throttle Control Lever** – Controls the speed of the engine. Pull the hand grip toward the operator to increase engine speed (high), away from the operator to decrease engine speed (low or idle).
5. **Throttle (Engine)** – Controls engine speed when throttle control lever is pulled toward the operator.
6. **V-Belt Cover** – Remove this cover to gain access to the V-belt. **NEVER** operate the trowel with this cover removed.
7. **Centrifugal Safety Stop Switch** – In the event the operator loses control of the trowel, this switch will shut-down the engine.
8. **Auxiliary Lifting Tube** - Use this tube to lift the trowel onto a slab. Tube is to be inserted into socket located in front of the gearbox.
9. **Stabilizer Ring** – Reduces trowel arm vibration. Helps stabilize trowel arm.
10. **Trowel Lifting Point** – Insert the auxiliary lifting tube here. See Figure 20.
11. **Pitch Control (standard models)** - Turn this "Star Wheel" clockwise for increase blade pitch, and counter-clockwise for decrease blade pitch.
12. **Blades** – This trowel is equipped with combination blades. These blades are versatile and should take care of most troweling needs. In addition float discs can be attached to the trowel arms that will allow the trowel to float on "wet" concrete.
13. **Main Tube** - When disassembling components inside the tube exercise extreme **CAUTION!** Tube is spring-loaded, severe injury could result if not disassembled correctly.
14. **Guard Ring- NEVER!** put hands or feet inside guard ring.
15. **Engine** – This trowel uses an 11HP or 13 HP Honda gasoline engine.
16. **Trowel Arm** – **NEVER** operate the trowel with a bent, broken or out of adjustment trowel arm. If the blades show uneven wear patterns or some blades wear out faster than others, the trowel arm may need to be adjusted. Use the trowel arm adjustment tool P/N 1817 to adjust the trowel arms.

BASIC ENGINE

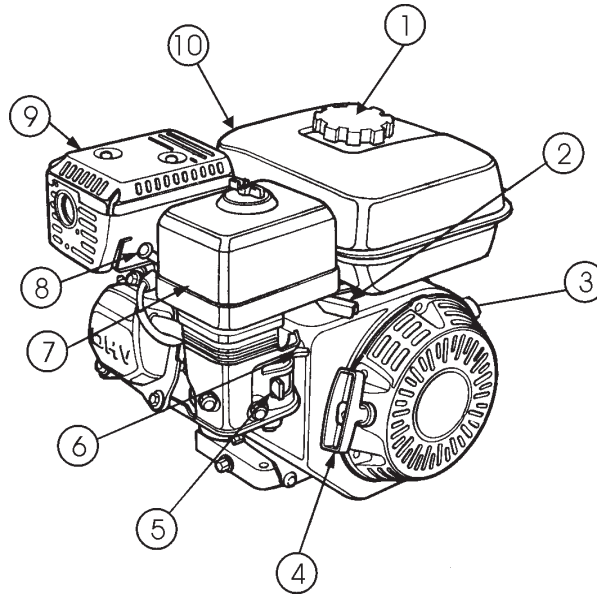

Figure 4. Engine Controls and Components

INITIAL SERVICING

The engine (Figure 4) must be checked for proper lubrication and filled with fuel prior to operation. Refer to the manufacturers engine manual for instructions & details of operation and servicing.

1. **Fuel Filler Cap** – Remove this cap to add unleaded gasoline to the fuel tank. Make sure cap is tightened securely. **DO NOT** over fill.



! DANGER

Adding fuel to the tank should be done only when the engine is stopped and has had an opportunity to cool down. In the event of a fuel spill, **DO NOT** attempt to start the engine until the fuel residue has been completely wiped up, and the area surrounding the engine is dry.

2. **Throttle Lever** – Used to adjust engine RPM speed (lever advanced forward **FAST**, lever back toward operator **SLOW**).
3. **Engine ON/OFF Switch** – ON position permits engine starting, OFF position stops engine operations.
4. **Recoil Starter (pull rope)** – Manual-starting method. Pull the starter grip until resistance is felt, then pull briskly and smoothly.
5. **Fuel Valve Lever** – **OPEN** to let fuel flow, **CLOSE** to stop the flow of fuel.

6. **Choke Lever** – Used in the starting of a cold engine, or in cold weather conditions. The choke enriches the fuel mixture.
7. **Air Cleaner** – Prevents dirt and other debris from entering the fuel system. Remove wing-nut on top of air filter cannister to gain access to filter element.

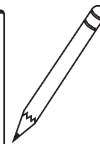
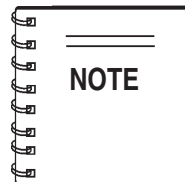

Operating the engine without an air filter, with a damaged air filter, or a filter in need of replacement will allow dirt to enter the engine, causing rapid engine wear.

8. **Spark Plug** – Provides spark to the ignition system. Clean spark plug once a week.
9. **Muffler** – Used to reduce noise and emissions.



! WARNING

Engine components can generate extreme heat. To prevent burns, **DO NOT** touch these areas while the engine is running or immediately after operating. **NEVER** operate the engine with the muffler removed.

10. **Fuel Tank** – Holds unleaded gasoline. For additional information refer to engine owner's manual.

ASSEMBLY AND INSTALLATION

ASSEMBLY AND INSTALLATION

Before the trowel can be put into operation there are some components that must be installed before the trowel can be used. This section provided general instructions on how to install those components. Instruction sheet P/N 20485 provides further details for the handle assembly.

Handle Tube Installation (All Models)

1. Install the **handle tube** to the gearbox as shown in (Figure 5). The mounting hardware should be contained in the shipping container.

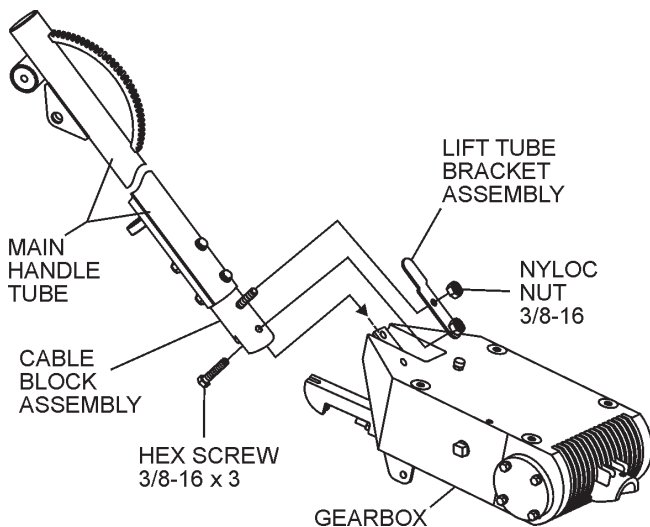

Figure 5. Handle Tube Installation

2. On Quick-Pitch™ models, pivot the **Quick-Pitch™ Handle** back (full pitch), (Figure 6). This will relax the spring inside the handle tube. On either model, spread the handle bar ends just enough to engage the teeth on the handle tube. Attach the hand wheel assembly, position handlebar to desired location, and tighten hand wheel firmly.

CAUTION



The Quick-Pitch™ handle is spring loaded, personal injury or damage could result from improper handling or installation. Be careful when installing this component.

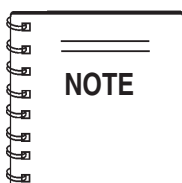

Considerable force may be required when moving the **Quick-Pitch™ Handle** forward or backward.

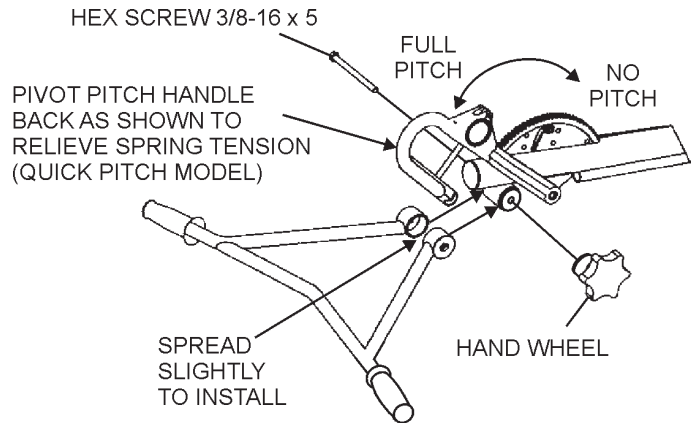

Figure 6. Handlebar Installation

Throttle Cable Installation

1. Place the throttle lever (Figure 7) to the idle position.

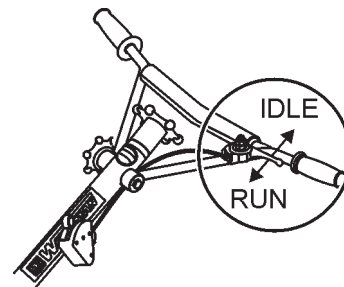

Figure 7. Throttle

2. Feed the throttle cable through the cable housing.
3. Connect the throttle cable to the engine (Figure 8). There should be a piece of wire installed on the trowel to show where to route the throttle cable. When connecting the cable housing, make sure that no more than **1/4" (6.4mm)** of the cable housing protrudes past the housing clamp on the engine.

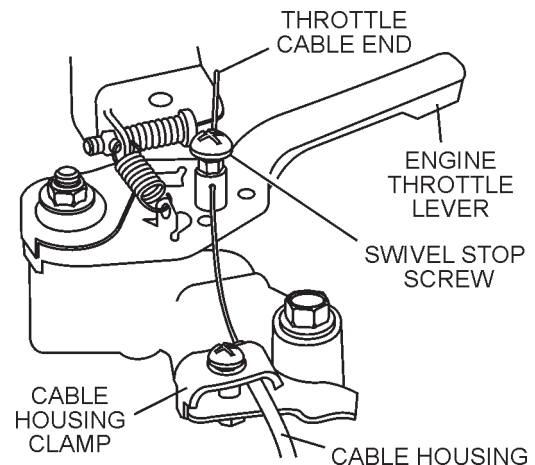

Figure 8. Throttle Cable Connection

ASSEMBLY AND INSTALLATION

4. Tighten cable clamp screw and swivel stop screw.
5. After the cable has been installed on the engine, adjust and tighten operator position of the handle to lock the throttle cable at the proper length.
6. Adjust cable tension loosening the lock nut on the throttle cable receiver (Figure 9), loosening or tightening the adjuster nut below it, then retightening the lock nut.

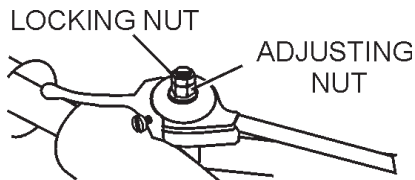

Figure 9. Throttle Adjust

7. Installation of the throttle cable may vary for different engine configurations. Please look for more detailed instructions inside the box containing the handle. These more detailed instructions should provide adequate guidance for installing.

Handle Height Adjustment

If handle height adjustment is desired, a handle wedge kit can be purchased for your trowel by ordering P/N 2576 from your Multiquip dealer. These wedges are placed between the handle and the gearbox to adjust the operating height of the handle. This kit comes complete with wedges, new bolts and installation instructions. This will move your operating handle position up or down approximately 3" (76 mm).

Safety Stop Switch Wire

Locate the **safety stop switch wire** protruding from the handle tube (Figure 10) and connect it to the **tail wire** on the engine. Test the safety stop switch to insure proper operation.

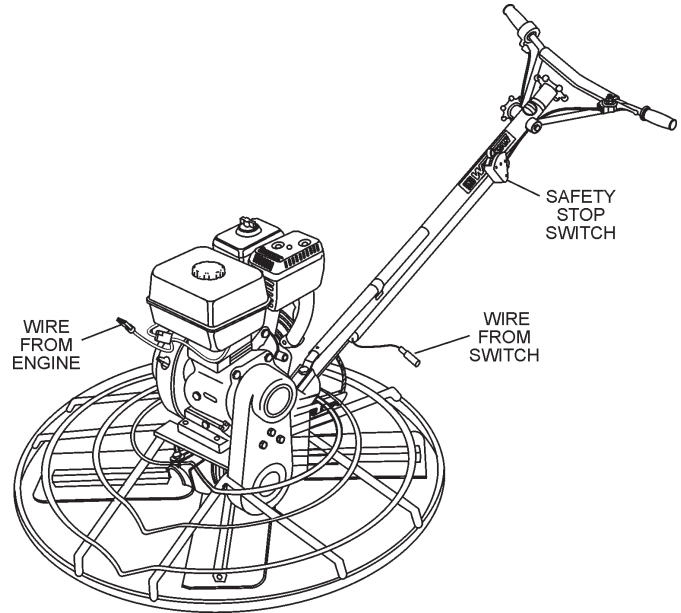

Figure 10. Engine Safety Stop Wire Connection

Pitch Cable Installation

1. Expose the pitch cable to maximum by adjusting the handle pitch to the "no pitch" position. On the standard model turn the pitch control counter-clockwise, (Figure 11). On the Quick-Pitch™ model, pivot the pitch handle forward or no pitch (Figure 12).

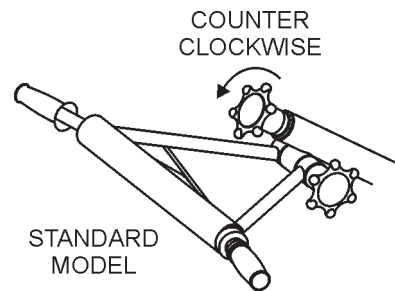

Figure 11. "No Pitch" Position (Standard)

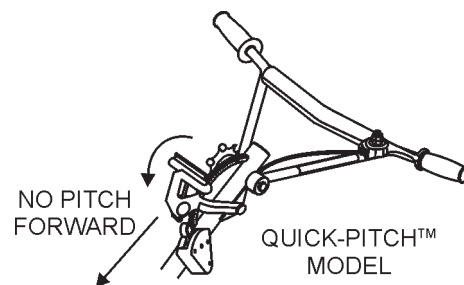

Figure 12. "No Pitch" Position (Quick-Pitch™)

ASSEMBLY AND INSTALLATION

2. Lock the spring in the compressed position, by releasing the blade pitch adjustment trigger, (Quick-Pitch™ model).
3. Remove one brass set nut from the blade pitch cable end as shown in (Figure 13).
4. Thread the second brass set nut towards the cable as far as possible.

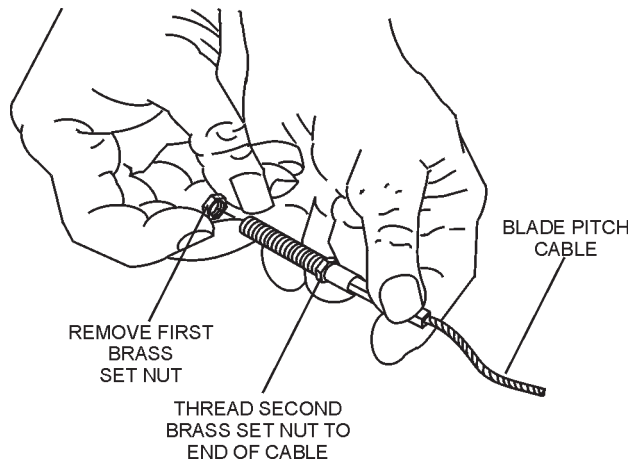

Figure 13. Blade Pitch Cable

5. Insert the cable end through the yoke eyelet (Figure 14). Tighten the first brass set nut by hand to remove all the slack from the cable.
6. Using a wrench, tighten the second brass set nut up against the yoke boss. This will lock the cable in place.
7. Use a wrench and finish tightening the first brass set nut up against the yoke boss.

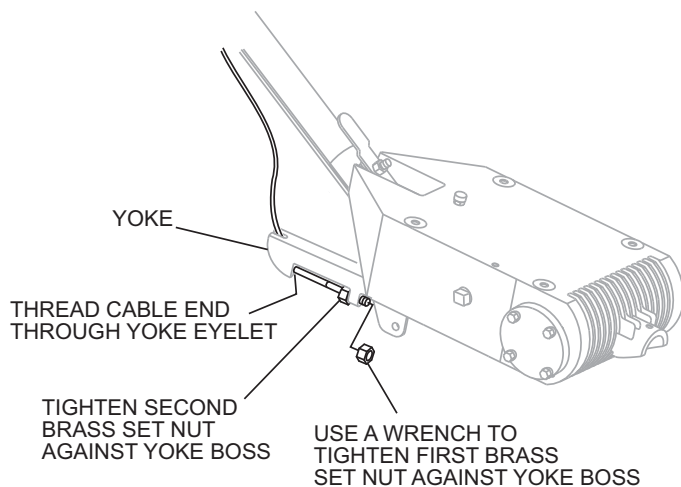

Figure 14. Cable Yoke Attachment

Pre-load Adjustment (Quick-Pitch™ Models Only)

1. After the Quick-Pitch™ handle has been installed on the trowel, spring pre-load adjustment will be required.
2. Locate the adjustment screw on the underside of the handle tube (Figure 15).

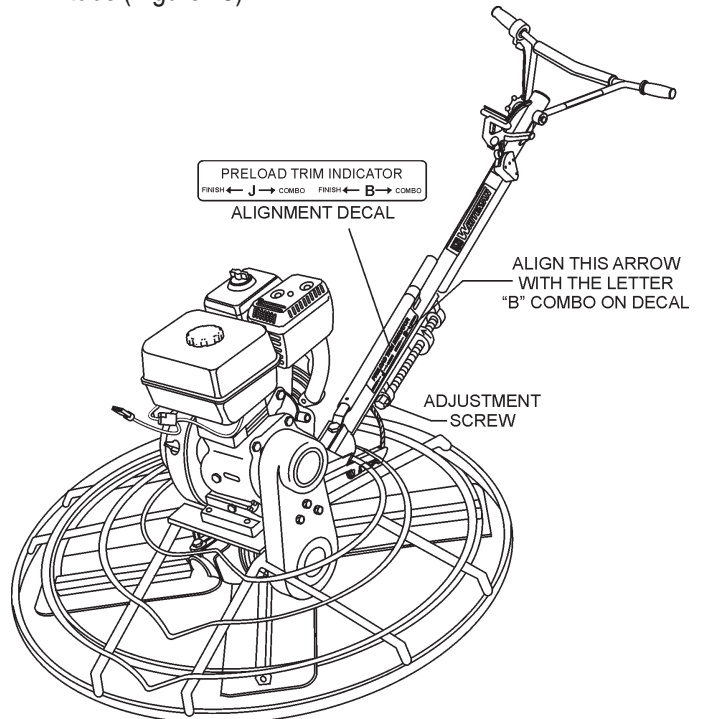

Figure 15. Pre-load Adjustment

3. A **decal** has been placed on the side of the handle tube to assist the user in the adjustment of the spring.
4. Align the **arrow** on the adjustment screw with the letter "**B**" **COMBO** on the **decal**.
5. Test the pitch control operation and adjust if necessary.
6. If less operator effort is desired to pitch the blades, move the indicator further in the "**COMBO**" direction.

PRE-INSPECTION

CAUTION



NEVER operate the trowel in a confined area or enclosed area structure that does not provide ample **free flow of air**.



ALWAYS wear approved eye and hearing protection before operating the trowel.

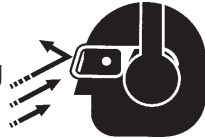

NEVER place hands or feet inside the guard rings while the engine is running. **ALWAYS** shut the engine down before performing any kind of maintenance service on the trowel.



It is recommended that the trowel's **safety stop switch** be used to stop the engine after every use. Doing this will verify that the switch is working properly and presents no danger to the operator.

Before Starting

1. Read safety instructions at the beginning of manual.
2. Clean the **trowel**, removing dirt and dust, particularly the engine cooling air inlet, carburetor and air cleaner.
3. Check the air filter for dirt and dust. If air filter is dirty, replace air filter with a new one as required.
4. Check carburetor for external dirt and dust. Clean with dry compressed air.
5. Check fastening nuts and bolts for tightness.

Engine Oil Check

1. To check the engine oil level, place the trowel on secure level ground with the engine stopped.
2. Remove the filler dipstick from the engine oil filler hole (Figure 16) and wipe it clean.

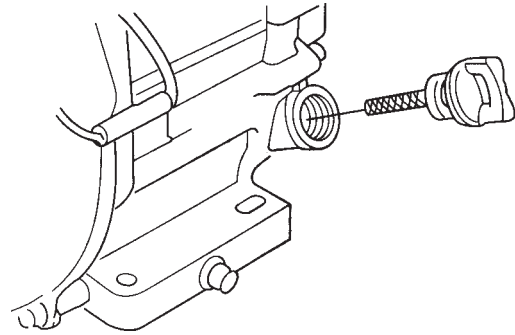
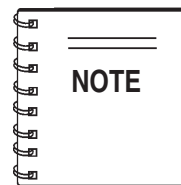

Figure 16. Engine Oil Dipstick (Removal)

3. Insert and remove the dipstick without screwing it into the filler neck. Check the oil level shown on the dipstick.
4. If the oil level is low (Figure 17), fill to the edge of the oil filler hole with the recommended oil type (Table 3). Maximum oil capacity is 1.16 US Qt. (1.1 liters).



Reference manufacturer engine manual for specific servicing instructions.

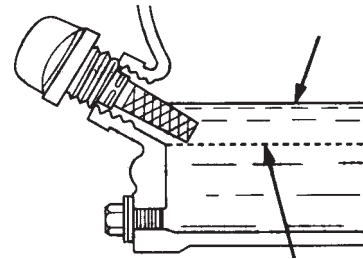

Figure 17. Engine Oil Dipstick (Oil Level)

Table 3. Oil Type

Season	Temperature	Oil Type
Summer	25°C or Higher	SAE 10W-30
Spring/Fall	25°C~10°C	SAE 10W-30/20
Winter	0°C or Lower	SAE 10W-10



Fuel Check

Motor fuels are highly flammable and can be dangerous if mishandled. **DO NOT** smoke while refueling. **DO NOT** attempt to refuel the trowel if the engine is **hot!** or **running**.

1. Remove the gasoline cap located on top of fuel tank.
2. Visually inspect to see if fuel level is low. If fuel is low, replenish with unleaded fuel.
3. When refueling, be sure to use a strainer for filtration. **DO NOT** top-off fuel. Wipe up any spilled fuel.

Gearbox Oil

1. Determine if the **gearbox** oil is low by removing the oil plug located on the side of the gearbox. This plug will be marked by the "**check**" decal (Figure 18). The correct level of the lubrication oil should be to the bottom of the fill plug.

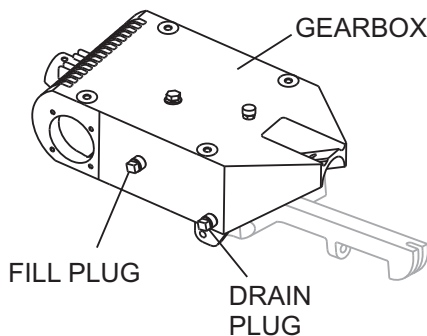

Figure 18. Gearbox

2. If lubrication oil begins to seep out as the drain plug is being removed, then it can be assumed that the gearbox has a sufficient amount of oil.
3. If lubrication oil does not seep out as the drain plug is being removed, fill with type ISO 680 (Whiteman P/N 10139) gearbox lubricant oil until the oil filler hole overflows.

V-belt Check

A worn or damaged V-belt can adversely affect the performance of the trowel. If a V-belt is defective or worn simply replace the V-belt as outlined in the maintenance section of this manual.

Blade Check

Check for worn or damaged blades. Check to see if one blade is worn out while the others look new. If this is the case there could be a blade pitch problem. Refer to the maintenance section of this manual for blade pitch adjustment procedure. Replace any worn blades.

CONTROLS

Safety Stop Switch

This trowel has been equipped with a centrifugal safety stop switch (Figure 19).

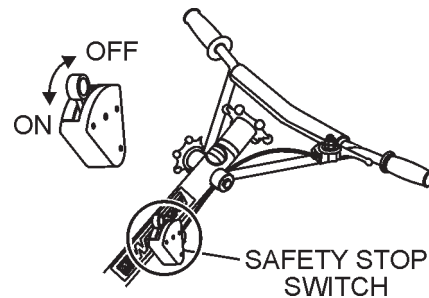
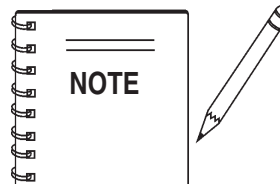

Figure 19. Centrifugal Safety Stop Switch

The switching mechanism of this switch should operate freely and should **always** be kept in this condition. With the switch in the **OFF** position, the engine should not start or run. The purpose of this switch is to stop the engine in a runaway situation, (i.e. the operator releasing the handle during operation). Safety stop switches should be tested every time the engine is started. See page 25 for procedures to check the operation of the Safety Stop Switch.



NEVER! disable or disconnect the safety stop switch. It is provided for operator safety. Injury may result if it is disabled, disconnected or improperly maintained.

INITIAL START-UP

INITIAL START-UP

DO NOT use your trowel until this section has been read and is thoroughly understood.

CAUTION



The trowel is **heavy** and **awkward** to move around. Use proper heavy lifting procedures and **DO NOT lift the trowel by the guard rings**.

Lifting the Trowel Onto a Slab

Auxiliary Lifting Tube

Remove the auxiliary lifting tube located on top of the main handle. Insert the tube into the socket located on the opposite side of the gearbox (Figure 20) from the handle.

Make sure that the hole in the tube engages with the pin in the socket. With one person lifting from the main handle, and another lifting from the auxiliary lifting tube pick up the machine to move onto a slab.

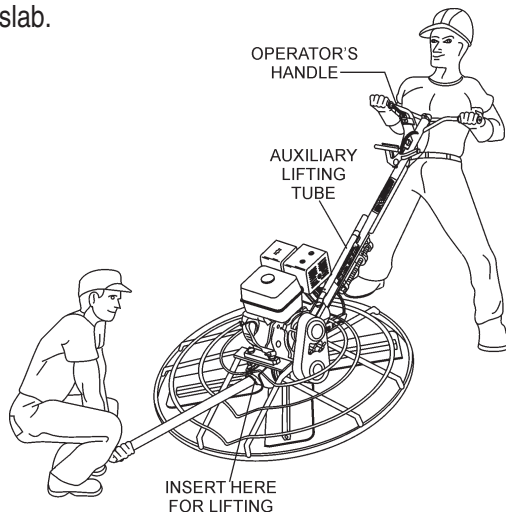

Figure 20. Lifting the Trowel

CAUTION



The trowel must be stabilized by the person carrying the **operator's handle** (Figure 20). If it is not stabilized properly the handle may swing around and **flip** the trowel, thus causing damage to the trowel and bodily injury.

Lifting Bail (Option)

The lift bail is optional on new trowels. It provides an optimal lift point for moving the trowel. **Lift bales** or **forklift** can be used to lift a trowel up onto a building with a crane. See "**Optional Equipment**" section in this manual for ordering information.

Using a **crane** to move a machine with a lift bail is highly recommended, and is perfectly safe for the machine. Extra care should be taken when lifting the machine off the ground, however. Serious damage to the machine or personal injury could be caused by dropping a trowel.

CAUTION



DO NOT attempt to operate the trowel until the Safety, General Information and Inspection sections of this manual have been read and thoroughly understood. Depending on engine manufacturer, operating steps may vary. See engine manufacturer's operating manual. The following start-up procedure makes reference to a **HONDA 11HP or 13HP Engine (Manual Start)**.

Starting the Engine

1. Place the engine **fuel valve lever** (Figure 21) to the "ON" position.

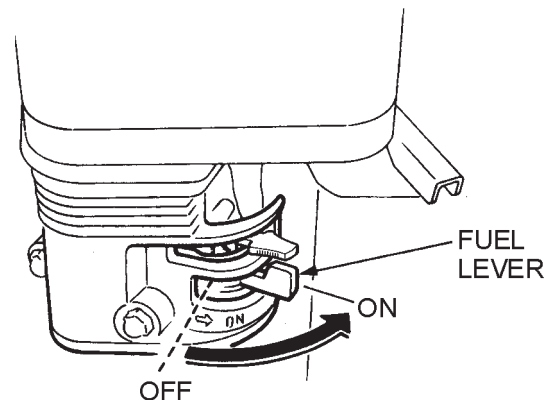

Figure 21. Engine Fuel Valve Lever

2. Move the throttle lever (Figure 22) to the "idle" position.

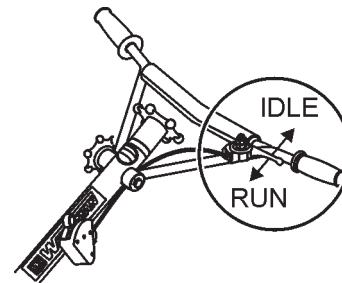

Figure 22. Throttle (Idle Position)

INITIAL START-UP

- Place the **centrifugal safety stop switch** (Figure 23) in the "ON" position.

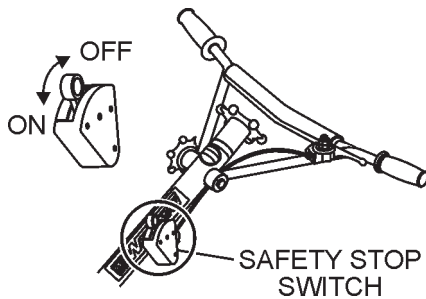

Figure 23. Centrifugal Safety Stop Switch

- Place the **Choke Lever** (Figure 24) in the "CLOSED" position.

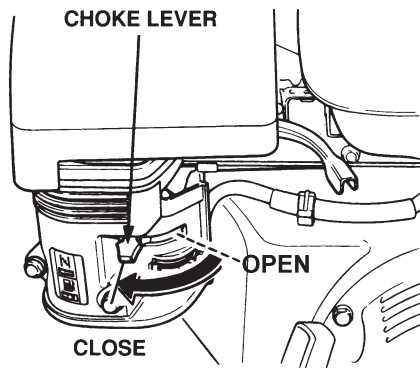

Figure 24. Engine Choke Lever

- Grasp the starter grip (Figure 25) and slowly pull it out. The resistance becomes the hardest at a certain position, corresponding to the compression point. Pull the starter grip briskly and smoothly for starting.

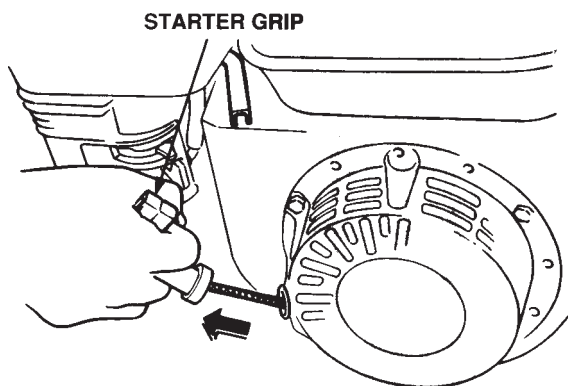

Figure 25. Starter Grip

- If the engine has started, slowly return the choke lever (Figure 24) to the **OPEN** position. If the engine has not started repeat steps 1 through 5.
- Before the trowel is placed into operation, run the engine for several minutes. Check for fuel leaks, and noises that would associate with a loose guard ring and/or covers.
- Test the Safety Stop Switch.
 - With the engine at idle, move the safety stop switch lever to "OFF" (Figure 23). The engine should shut off.
 - CLEAR THE AREA AROUND THE TROWEL.** Move the safety stop switch lever back to the "ON" position, restart the engine and let idle. Stand behind the handle and spin the handle to the right, simulating a runaway situation. (See Figure 26). Centrifugal force should throw the safety switch outward to the "OFF" position thus shutting off the engine

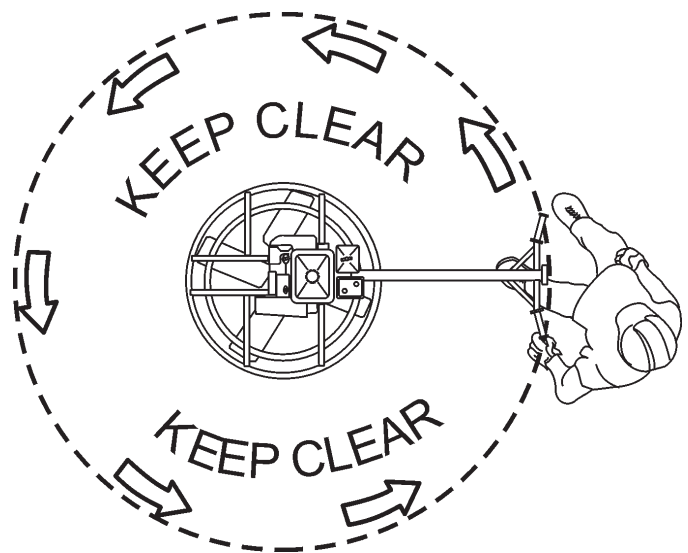

Figure 26. Testing the Centrifugal Safety Stop Switch

- To begin troweling, push the throttle lever (Figure 27) toward the "RUN" position.

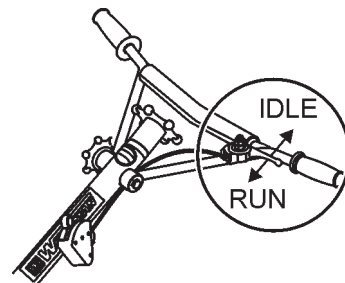

Figure 27. Throttle (Run Position)

OPERATION

The following steps are intended as a basic guide to machine operation, and are not to be considered a complete guide to concrete finishing. We suggest that all operators (experienced and novice) read "**Slabs on Grade**" published by the **American Concrete Institute, Detroit, Michigan**. Read the "Training" section of this manual for more information.

Pitching The Blades

Quick-Pitch™ Handle

To pitch the blades upwards using the "**Quick-Pitch™**" handle, (Figure 28) simply squeeze the trigger lock and pull the handle toward the operator. Pushing the handle toward the engine will cause the blades to lay flat.

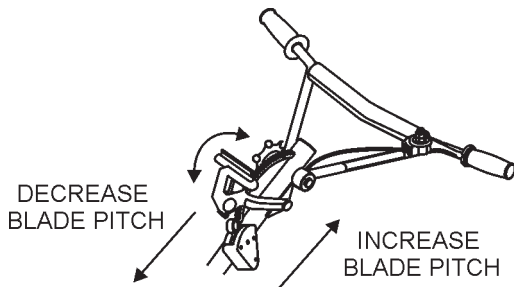

Figure 28. Quick-Pitch™ Handle

Standard Handle

To pitch the blades upwards using the "**Standard**" handle, (Figure 29) simply turn the **star-wheel** clockwise. Turning the star wheel counter clockwise will cause the blades to lay flat.

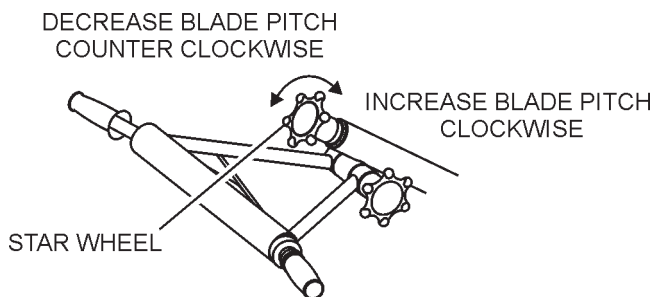

Figure 29. Standard Handle

Maneuvering the Trowel

1. Get into the operator's position behind the handle. With a secure foothold and a firm grasp on the handles slowly increase the engine speed until the desired blade speed is obtained.
2. To maneuver the trowel, gently lift up on or press down on the main trowel handle. To move the machine to the operator's left, **lift up** on the handle, to move machine to the right, **push down** on the handle.
3. The best method for finishing concrete is to slowly walk backwards (Figure 30) with the trowel, guiding the trowel from side to side. This will cover all footprints on wet concrete.
4. Remember that if you let go of the trowel, just step away and let the trowel come to a complete stop before trying to recover the trowel. See (Figure 26) to see the area around the trowel to keep clear of.

OPERATION

(Figure 30) below illustrates a typical walk-behind trowel application. Practice maneuvering the trowel. The trick is to let the trowel do the work.

Continue to practice maneuvering the trowel. Try to practice as if you were finishing a slab of concrete. Practice edging and covering a large area. Remember a good finishing technique is to work backwards. Be careful when moving backwards so that hazards can be avoided. The best way to get accustomed to the trowel is repeated use.

To move the trowel to the operator's left, **lift up** on the handle, to move the trowel to the right **push down** on the handle.

Remember! that if you let go of the trowel, just **step away** and let the trowel come to a complete **STOP** before trying to recover the trowel.

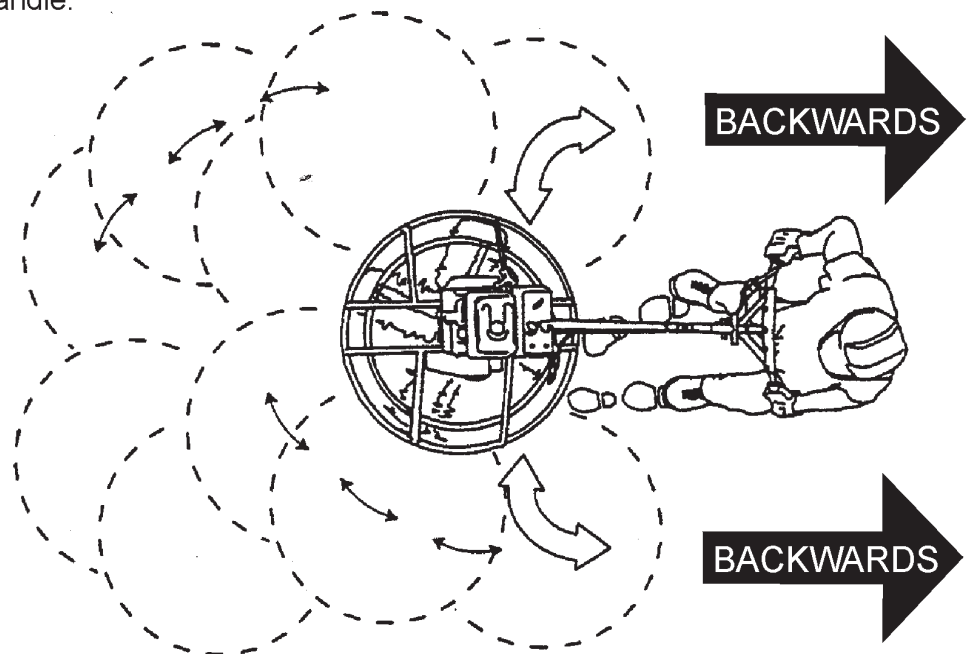

The best method for finishing concrete is to slowly walk **backwards** with the trowel, guiding the trowel from side to side. This will cover all footprints on wet concrete.

Figure 30. Maneuvering The Trowel

CAUTION



NEVER place your **feet** or **hands** inside the guard rings while starting or operating this equipment.

CAUTION



ALWAYS keep clear of **rotating** or **moving** parts while operating this equipment.

OPTIONS

Blades



Blades should be changed when they fail to finish concrete in a satisfactory manner.

Blades are a vital part of finishing concrete. This trowel, or **finisher**, has been designed to finish concrete and the blades are built to stringent quality standards out of the finest trowel steel. If you need replacement blades, consult your parts list in this manual for part numbers and order them from your Multiquip parts dealer or importer.

Combo Blades

This trowel was equipped with combination **float/finish** (Figure 31) blades as original equipment. These blades have been designed for optimum performance in both the floating and finishing operations. These blades are versatile and should take care of most troweling needs.

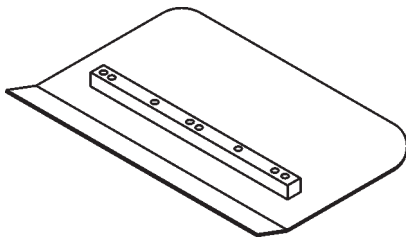

Figure 31. Combination Blade

Finish Blades (Optional)

These blades (Figure 32) have been specifically designed for finish operations with this trowel. They will provide a premium surface finishing capability from your trowel. They should only be used after the concrete has set to the point where the trowel does not sink into the concrete when placed on it.

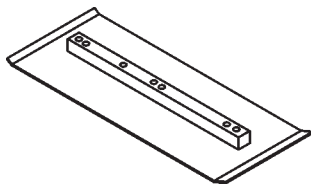

Figure 32. Finish Blade

Clip-On Float Blades (Optional)

These blades will clip (Figure 33) on to an existing installed blade, allowing your finisher to float on “wet” concrete so that the troweling operation can begin as early as possible. They are easily removable, so that after the floating operation, when the concrete is sufficiently cured, they can be removed to expose the finish blades for continued troweling.

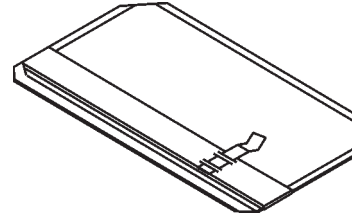

Figure 33. Clip-On Float Blade

Float Discs (Optional)

These round discs (Figure 34) attach to the spiders and allow the machine to “float” on “wet” concrete. The disc design allows early floating and easy movement from wet to dry areas. They are also very effective in embedding large aggregates and surface hardeners.

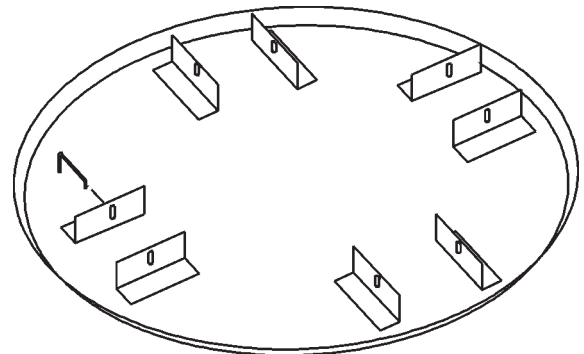

Figure 34. Float Disk

Lifting Bail

There is a heavy duty, center balance type lifting bail (Figure 35) made specifically for your trowel. These bales are ideal for lifting and transporting your trowel. They are designed to lift the finisher and balance it on it's center of gravity, providing great stability while lifting. This option is not available on electric trowel models.

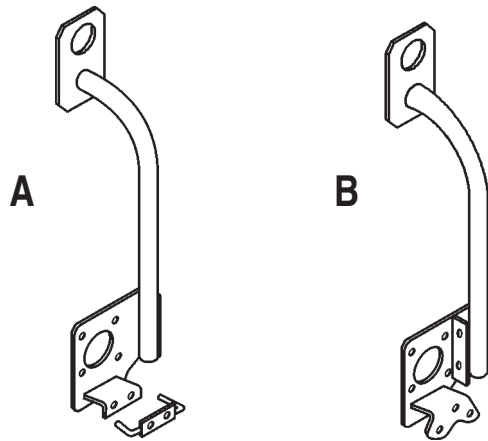

Figure 35. Lifting Bail

- A. P/N 10157 (11 HP Engine)
- B. P/N 11554 (13 HP Engine)

Trowel Arm Adjustment Tool

If blades show uneven wear patterns or some tend to wear out faster than others, the trowel arms may need to be adjusted. Whiteman makes a special tool (Figure 36) that will adjust all of the trowel arms consistently. The Trowel Arm Fixture P/N is 1817.

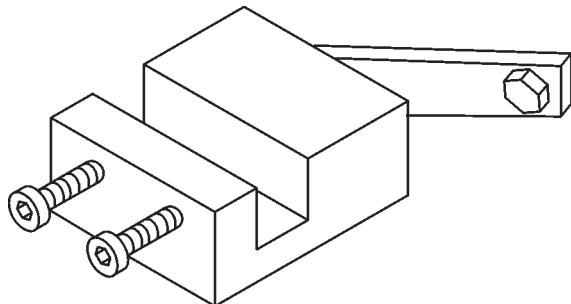
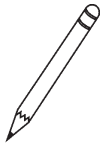
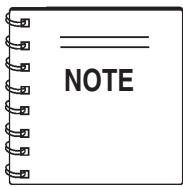

Figure 36. Trowel Arm Adjustment Fixture

MAINTENANCE



See the engine manual supplied with your machine for appropriate engine maintenance schedule and troubleshooting guide for problems.

At the front of the book (Page 7) there is a “**Daily Pre-Operation Checklist**”. Make copies of this checklist and use it on a daily basis.

CAUTION!

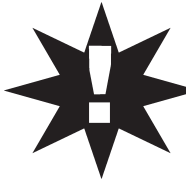

ALWAYS allow the engine to cool before servicing. **NEVER** attempt any maintenance work on a **hot!** engine.



MAINTENANCE SCHEDULE

Daily (8-10 Hours)

1. Check the oil level in the engine crankcase and gear box, fill as necessary.
2. Check V-belt.

Weekly (50-60 Hours)

1. Relube arms, thrust collar and clutch.
2. Replace blades if necessary.
3. Check and clean or replace the engine air filter as necessary.
4. Replace engine oil and filter as necessary, see engine manual.

Monthly (200-300 Hours)

1. Remove, clean, reinstall and relube the arms and thrust collar. Adjust the blade arms.
2. Remove, clean, reinstall clutch.

Yearly (2000-2500 Hours)

1. Check and replace if necessary the arm bushings, thrust collar bushings and shaft seals.
2. Check pitch control cables for wear.
3. Adjust blade speed.

Trowel Arm Adjustment Procedure

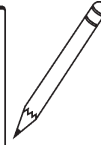
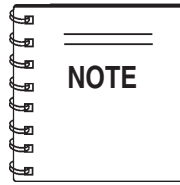

The following procedure should be followed to adjust trowel arms when it becomes apparent that the trowel is finishing poorly or in need of routine maintenance.

A **level**, clean area to test the trowel prior to and after is essential. Any unlevel **spots** in the floor or debris under the trowel blades will give an incorrect perception of adjustment. Ideally, a 5 x 5" three-quarter inch thick **flat** steel plate should be used for testing.

1. To determine which blades need adjustment, place the trowel in the test area (three-quarter inch thick plate) and look for the following conditions:

- Pitch the blades as flat as possible and look at the **adjustment bolts**. They should all barely make contact with the **lower wear plate** on the spider. If you can see that one of them is not making contact, some adjustment will be necessary.

- Is the machine wearing out blades unevenly (i.e. one blade is completely worn out while the others look new)?

(Figure 37) below illustrates “**worn spider bushings or bent trowel arms**”. Check to see that adjustment bolt is barely touching (0.010" max. clearance) lower wear plate. All alignment bolts should be spaced the same distance from the lower wear plate.

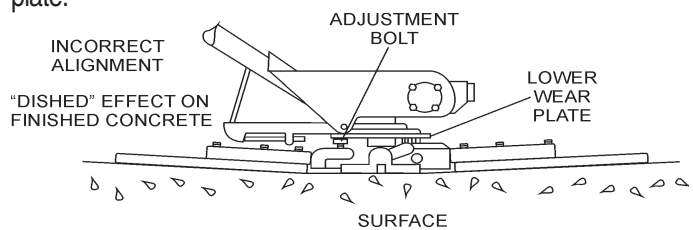

Figure 37. Worn Spider Plate

(Figure 38) below illustrates the “**correct alignment**” for a spider plate (as shipped from the factory).

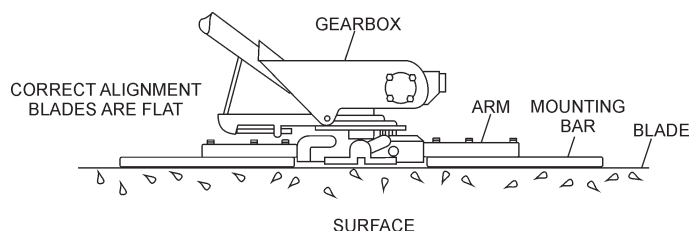

Figure 38. Correct Spider Plate Alignment

2. Start engine, and bring trowel blades up to full speed and look for the following conditions:
 - Does the trowel have a perceived rolling or bouncing motion when in use?
 - Look at the trowel while it is running, does the guard ring “rock up and down” relative to the ground?

Spider Removal

Once it is determined that an adjustment is required, remove the spider assembly from the gearbox shaft as follows:

1. Locate the cone point square head set screw (Figure 39) and attached jam nut found on the side of the spider assembly.

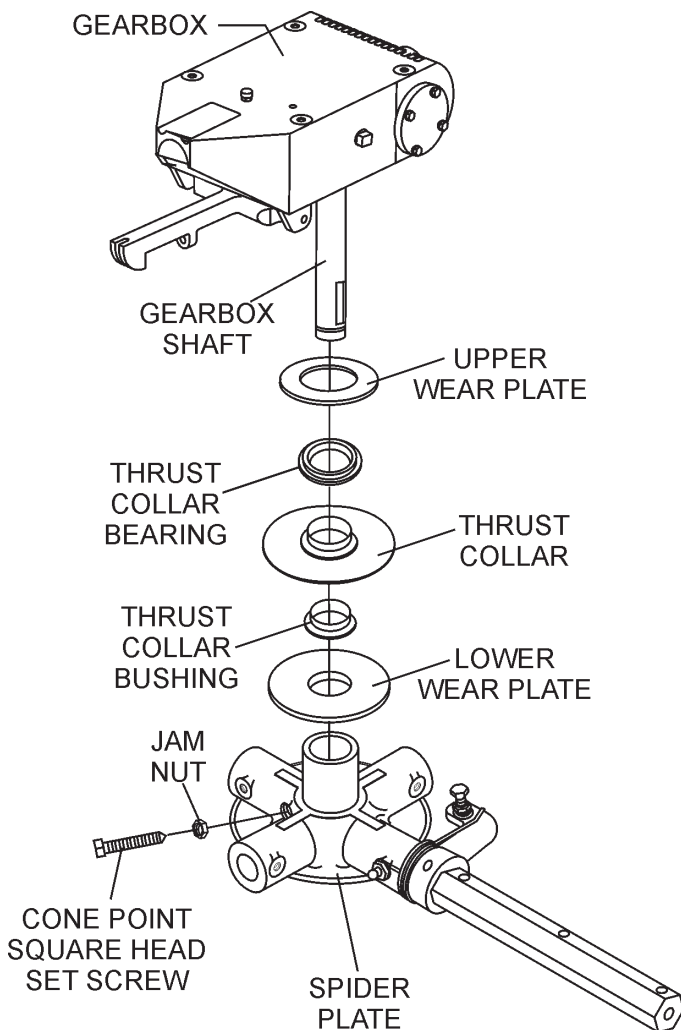

Figure 39. Spider/Gearbox Removal

2. Loosen the jam nut and cone point square head set screw, and carefully lift the **upper trowel assembly** off of the spider assembly. A slight tap with a rubber mallet may be necessary to dislodge the spider from the main shaft of the gearbox.
3. If the trowel is equipped with an outer stabilizer ring (Figure 40), remove the four bolts at the end of each spider arm.

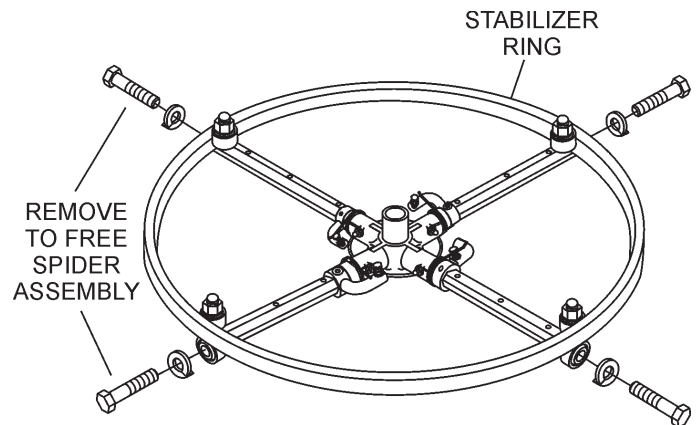

Figure 40. Stabilizer Ring

4. Examine stabilizer ring for out of round or bends. If ring is damaged, replace ring. If ring is found to be correct with no damage, set aside.

Trowel Arm Removal

1. Each trowel arm is held in place at the spider plate by a hex head bolt (zerk grease fitting) and a roll pin. Remove both the hex head bolt and the roll pin (Figure 41) from the spider plate.
2. Remove the trowel arm from the spider plate.

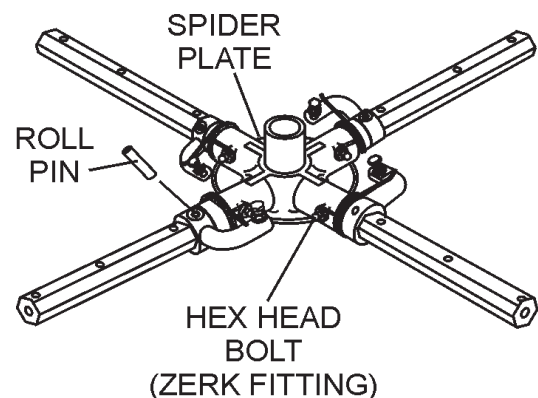

Figure 41. Removing Roll Pin and Zerk Grease Fitting

- Should the trowel arm inserts (bronze bushing) come out with the trowel arm, remove the bushing from the trowel arm and set aside in a safe place. If the bushing is retained inside the spider plate, carefully remove the bushing.
- Examine the bronze trowel arm bushing insert (Figure 42), clean if necessary. Replace bushing if out of round or worn.

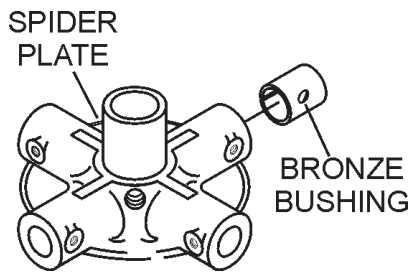

Figure 42. Bronze Bushings

Trowel Blade Removal

- Remove the trowel blades from the trowel arm by removing the three hex head bolts (Figure 43) from the trowel arm. Set blades aside.

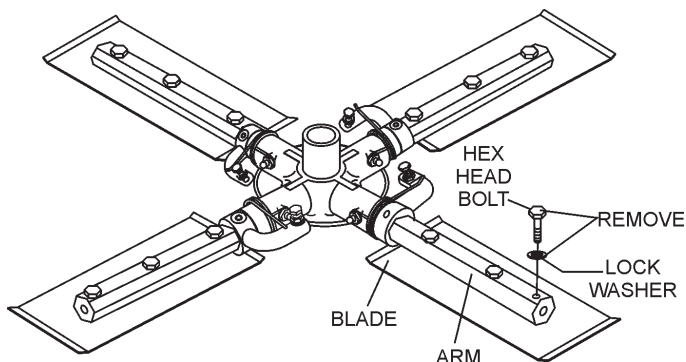

Figure 43. Trowel Blades

- Wire brush** any build-up of concrete from all six sides of the trowel arm. Repeat this for the remaining three arms.

Trowel Arm Flatness Test

- Using a piece of 3/4 inch thick steel plate or any surface which is **true** and **flat**, check all **six sides** of each trowel arm for flatness.
- Check each of the six sides of the trowel arm (hex section only) using a ten thousands of an inch (max.) feeler gauge (Figure 44) between the flat of the trowel arm and an **extremely flat** test surface.

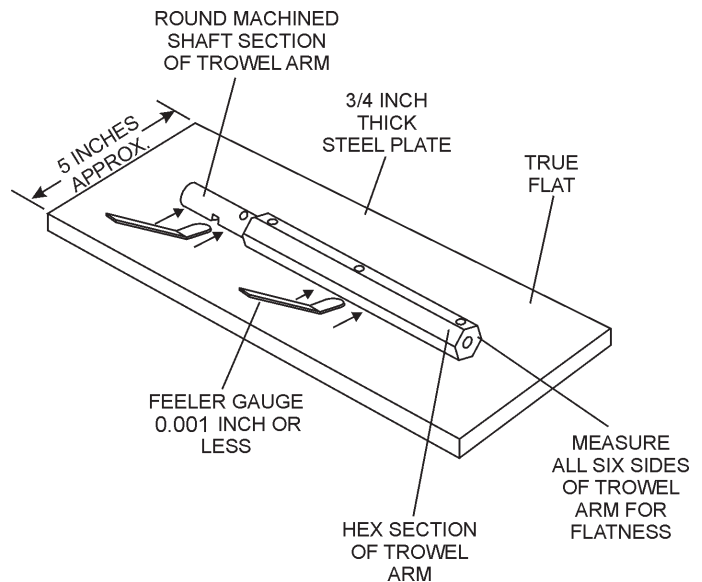
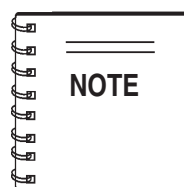

Figure 44. Trowel Arm Flatness Test

- If the trowel arm is found to be **uneven** or **bent**, replace the trowel arm. A bent trowel will not allow the trowel to operate in a smooth fluid rotation.
- Next, check each of the six sides of the round machined shaft section of the trowel arm. Each section should have the **same clearance** between the round of the trowel arm shaft and the test surface.



Trowel arms can be damaged by rough handling or by striking exposed plumbing or forms while in operation. **ALWAYS** look-out for objects which might cause damage to the trowel arms.

Trowel Arm Adjustment

Shown in (Figure 45) is the adjustment fixture with a trowel arm inserted. As each trowel arm is locked into the fixture, the arm bolt is adjusted to where it contacts a stop on the fixture. This will consistently adjust all of the trowel arms, keeping the finisher as flat and evenly pitched as possible.

1. Locate the trowel arm adjustment tool P/N 1817. Set the adjustment tool for a clockwise blade rotation, meaning the fixture arm is in the "UP" position.

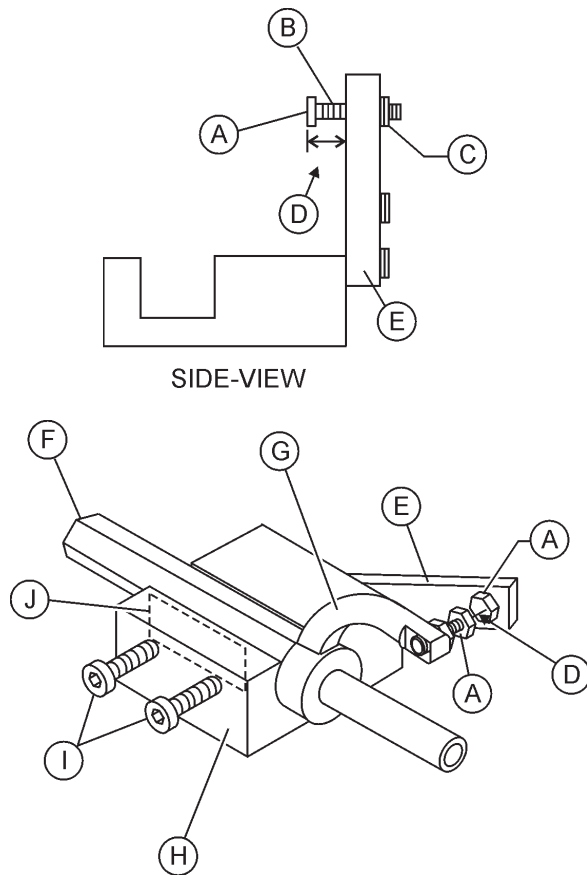

Figure 45. Trowel Arm Adjustment Tool

- | | |
|---------------------|-------------------------|
| A. Adjustment Bolt | B. Adjust as in Step 2 |
| C. Locking Nut | D. Distance (.010 Inch) |
| E. Fixture Arm | F. Arm |
| G. Trowel Arm Lever | H. Fixture P/N 1817 |
| I. Locking Bolts | J. Shim |

2. Adjust the adjustment bolt to fit the tallest adjustment screw, then adjust the other arms to match.

3. Unscrew the locking bolts on the adjustment tool, and place the trowel arm into the adjustment fixture channel (Figure 45). A **thin shim** may be required to cover the blade holes on the trowel arm. Make sure to align the trowel adjustment bolt with the fixture adjustment bolt.
4. Using an allen wrench, tighten the locking bolts on the adjustment tool and securely lock the trowel arm in place.
5. Loosen the locking nut on the trowel arm lever, then turn the trowel arm adjusting bolt until it barely touches (.010") the adjusting bolt on the fixture.
6. After the correct adjustment has been made, tighten lock nut on trowel arm lever to lock in place.
7. Loosen locking bolts on adjustment fixture, and remove trowel arm from fixture.
8. Repeat steps 2-7 for the remaining trowel arms.

Re-Assembly

1. Clean and examine the upper/lower wear plates and thrust collar. Examine the entire spider assembly. Wire brush any concrete or rust build-up. If any of the spider components are found to be damaged or out of round, replace them.
2. Make sure that the bronze trowel arm bushing is not damaged or out of round. Clean the bushing if necessary. If the bronze bushing is damaged or worn, replace it.
3. Reinstall bronze bushing onto trowel arm.
4. Repeat steps 2-3 for each trowel arm.
5. Make sure that the spring tensioner is in the correct position to exert tension on the trowel arm.
6. Insert all trowel arms with levers into spider plate (with bronze bushing already installed) using care to align grease hole on bronze bushing with grease hole fitting on spider plate.
7. Lock trowel arms in place by tightening the hex head zerk grease fitting and jam nut.
8. Re-install the blades back onto the trowel arms.
9. Install stabilizer ring onto spider assembly.
10. Reinstall **lower wear plate**, **thrust collar** and **upper wear ring** in the **reverse order** that they were dis-assembled onto the spider shaft. Make sure that there is little or no lateral movement between the thrust collar and the spider shaft.

11. Carefully lift *the upper trowel assembly*, line up the key-way on gear box main shaft and insert into spider assembly.
12. Reinstall square head cone point into spider plate and tighten in place. Tighten jam nut. Use care in making sure point of set screw engages groove in gear box main shaft.
13. Lubricate all grease points (zerk fittings) with premium "**Lithum 12**" based grease, conforming to NLG1 Grade #2 consistency.

Testing

1. Place trowel in test area, start engine and test trowel for smoothness.
2. If trowel bounces has excessive vibration or does not run smoothly repeat alignment procedure.

Changing a Blade

Whiteman recommends that ***all the blades be changed at the same time***. The machine may wobble or bounce if only some of the blades are changed at one time.

1. Place the machine on a flat, level surface. Adjust the blade pitch control to make the blades as flat as possible. Note the blade orientation on the trowel arm.

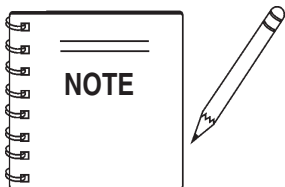

Before removing the blades, please note the orientation of the blade on the trowel arm.

2. Remove the three bolts and lock washers that secure the blade to the trowel arm. Remove the blade.
3. Using a wire brush, scrape all concrete particles and foreign debris from the trowel arm.
4. Install the new trowel blade onto the trowel arm. Make sure blade is installed correctly, maintaining the proper orientation for direction of rotation.
5. Reinstall the three bolts and lock washers that secure the blade to the trowel arm. Tighten all three bolts securely.
6. Repeat steps 1- 5 for all remaining blades.

V-Belt Removal and Replacement

1. Remove the two T-Bolts and lock-washers that hold on the belt guard and remove the belt guard.
2. Work the belt up and over the bottom pulley and remove the belt.
3. Replace with the appropriate belt:
HDA 11HP HONDA: **P/N 0261**, A31 GATES HP11 (2 each)
HDA 13HP HONDA: **P/N 11537**, HOFFCO-COMET
4. Place the belt in the upper pulley groove then work the belt over the bottom pulley into place.

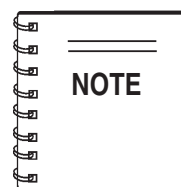

The V-Belt will tension itself automatically during operation. **NO FURTHER ADJUSTMENT OR TENSIONING IS NECESSARY.**

6. Replace the belt guard, lock-washers, and secure with the T-Bolts.



WARNING

NEVER operate equipment with covers, or guards removed. Keep fingers, **hands**, **hair** and **clothing** away from all moving parts to prevent injury.

Engine

Follow the maintenance procedures outlined in the engine owner's manual.

Engine Oil Change

Drain the used oil while the engine is warm by the following:

1. Place an oil pan or suitable container below the engine drain plug to catch the used oil.
2. Remove the filler cap/dipstick and the drain plug.
3. Drain the oil completely and reinstall the drain plug. Ensure the drain plug is tightened securely.
4. With the engine in a level position, fill to the outer edge of the oil filler hole with the recommended oil.
5. Screw in the filler cap/dipstick securely.

Dispose of used oil properly. **DO NOT** pour used oil on the ground, down a drain, or throw in the trash. Used oil can generally be taken to your local recycling center or service station for reclamation.

TROUBLESHOOTING (TROWEL)

TABLE 4. TROUBLESHOOTING (TROWEL)

SYMPTOM	POSSIBLE PROBLEM	SOLUTION
Engine running rough or not at all.	Kill switch malfunction?	Make sure that the kill switch is ON or replace switch if necessary.
	Fuel?	Look at the fuel system. Make sure there is fuel being supplied to the engine. Check to ensure that the fuel filter is not clogged.
	Ignition?	Check to ensure that the ignition switch has power and is functioning correctly.
Safety kill switch not functioning.	Other problems?	Consult engine manufacturer's manual.
	Loose wire connections?	Check wiring. Replace as necessary.
	Bad contacts?	Replace switch.
If trowel "bounces, rolls concrete, or makes uneven swirls in concrete".	Blades?	Make certain blades are in good condition, not excessively worn. Finish blades should measure no less than 2" (50mm) from the blade bar to the trailing edge, combo blades should measure no less than 3.5" (89mm). Trailing edge of blade should be straight and parallel to the blade bar.
	Spider?	Check that all blades are set at the same pitch angle as measured at the spider. A field adjustment tool is available for height adjustment of the trowel arms (see Optional Equipment).
	Bent trowel arms?	Check the spider assembly for bent trowel arms. If one of the arms is even slightly bent, replace it immediately.
	Trowel arm bushings?	Check the trowel arm bushings for tightness. This can be done by moving the trowel arms up and down. If there is more than 1/8" (3.2 mm) of travel at the tip of the arm, the bushings should be replaced. All bushings should be replaced at the same time.
	Thrust collar?	Check the flatness of the thrust collar by rotating it on the spider. If it varies by more than 0.02" (0.5 mm) replace the thrust collar.
	Thrust collar bushing?	Check the thrust collar by rocking it on the spider. If it can tilt more than 3/32" (2.4 mm) [as measured at the thrust collar O.D.], replace the bushing in the thrust collar.
	Thrust bearing worn?	Check the thrust bearing to see that it is spinning free. Note: Thrust cap, replace if necessary.
Machine has a perceptible rolling motion while running.	Main shaft?	The main output shaft of the gearbox assembly should be checked for straightness. The main shaft must run straight and cannot be more than 0.003" (0.08 mm) out of round at the spider attachment point.
	Yoke?	Check to make sure that both fingers of the yoke press evenly on the wear cap. Replace yoke as necessary.
	Blade Pitch?	Check to ensure that each blade is adjusted to have the same pitch as all other blades. Adjust per maintenance section in manual.

TROUBLESHOOTING (TROWEL)

TABLE 4. TROUBLESHOOTING TROWEL (CONTINUED)

SYMPTOM	POSSIBLE PROBLEM	SOLUTION
Clutch slipping or sluggish response to engine speed change.	Worn V-belts?	Replace V-belt.
	Dirty centrifugal clutch?	Disassemble and clean clutch.
	Defective or worn out centrifugal clutch?	Replace entire clutch.
	Hand clutch out of adjustment?	Adjust per instructions in maintenance section of this manual.
	Worn or defective hand clutch parts?	Replace parts as necessary.
	Worn bearings in gearbox?	Rotate input shaft by hand. If shaft rotates with difficulty, check the input and output shaft bearings. Replace as necessary.
	Worn or broken gears in gearbox?	Verify that the gearbox shaft rotates when the input shaft is rotated. Replace both the worm and worm gear as a set.

TROUBLESHOOTING (ENGINE)

TABLE 5. TROUBLESHOOTING (ENGINE)		
SYMPTOM	POSSIBLE CAUSE	SOLUTION
Difficult to start, "fuel is available, but no SPARK at spark plug".	Spark plug bridging?	Check gap, insulation or replace spark plug.
	Carbon deposit on spark plug?	Clean or replace spark plug.
	Short circuit due to deficient spark plug insulation?	Check spark plug insulation, replace if worn.
	Improper spark plug gap?	Set to proper gap.
Difficult to start, "fuel is available, and SPARK is present at the spark plug".	ON/OFF switch is shorted?	Check switch wiring, replace switch.
	Ignition coil defective?	Replace ignition coil.
	Improper spark gap, points dirty?	Set correct spark gap and clean points.
	Condenser insulation worn or short circuiting?	Replace condenser.
	Spark plug wire broken or short circuiting?	Replace defective spark plug wiring.
Difficult to start, "fuel is available, spark is present and compression is normal"	Wrong fuel type?	Flush fuel system, and replace with correct type of fuel.
	Water or dust in fuel system?	Flush fuel system.
	Air cleaner dirty?	Clean or replace air cleaner.
	Choke Open?	Close Choke.
Difficult to start, "fuel is available, spark is present and compression is low"	Suction/exhaust valve stuck or protruded?	Re-seat valves.
	Piston ring and/or cylinder worn?	Replace piston rings and or piston.
	Cylinder head and/or spark plug not tightened properly?	Torque cylinder head bolts and spark plug.
	Head gasket and/or spark plug gasket damaged?	Replace head and spark plug gaskets.
No fuel present inside priming bulb.	Fuel not available in fuel tank?	Fill with correct type of fuel.
	Fuel filter clogged?	Replace fuel filter.
	Fuel tank cap breather hole clogged?	Clean or replace fuel tank cap.
	Air in fuel line?	Bleed fuel line.

EXPLANATION OF CODES

The following section explains the different symbols and remarks used in the Parts section of this manual. Use the help numbers found on the back page of the manual if there are any questions.

NOTICE

The contents and part numbers listed in the parts section are subject to change **without notice**. Multiquip does not guarantee the availability of the parts listed.

SAMPLE PARTS LIST

NO.	PART NO.	PART NAME	QTY.	REMARKS
1	12345	BOLT.....	1	INCLUDES ITEMS W/%
2%		WASHER, 1/4 IN.....		NOT SOLD SEPARATELY
2%	12347	WASHER, 3/8 IN....	1	MQ-45T ONLY
3	12348	HOSE		A/R ...MAKE LOCALLY
4	12349	BEARING	1	S/N 2345B AND ABOVE

NO. Column

Unique Symbols — All items with same unique symbol

(@, #, +, %, or >) in the number column belong to the same assembly or kit, which is indicated by a note in the “Remarks” column.

Duplicate Item Numbers — Duplicate numbers indicate multiple part numbers, which are in effect for the same general item, such as different size saw blade guards in use or a part that has been updated on newer versions of the same machine.

NOTICE

When ordering a part that has more than one item number listed, check the remarks column for help in determining the proper part to order.

PART NO. Column

Numbers Used — Part numbers can be indicated by a number, a blank entry, or TBD.

TBD (To Be Determined) is generally used to show a part that has not been assigned a formal part number at the time of publication.

A blank entry generally indicates that the item is not sold separately or is not sold by Multiquip. Other entries will be clarified in the “Remarks” Column.

QTY. Column

Numbers Used — Item quantity can be indicated by a number, a blank entry, or A/R.

A/R (As Required) is generally used for hoses or other parts that are sold in bulk and cut to length.

A blank entry generally indicates that the item is not sold separately. Other entries will be clarified in the “Remarks” Column.

REMARKS Column

Some of the most common notes found in the “Remarks” Column are listed below. Other additional notes needed to describe the item can also be shown.

Assembly/Kit — All items on the parts list with the same unique symbol will be included when this item is purchased.

Indicated by:

“INCLUDES ITEMS W/(unique symbol)”

Serial Number Break — Used to list an effective serial number range where a particular part is used.

Indicated by:

“S/N XXXXX AND BELOW”

“S/N XXXX AND ABOVE”

“S/N XXXX TO S/N XXX”

Specific Model Number Use — Indicates that the part is used only with the specific model number or model number variant listed. It can also be used to show a part is NOT used on a specific model or model number variant.

Indicated by:

“XXXXX ONLY”

“NOT USED ON XXXX”

“Make/Obtain Locally” — Indicates that the part can be purchased at any hardware shop or made out of available items. Examples include battery cables, shims, and certain washers and nuts.

“Not Sold Separately” — Indicates that an item cannot be purchased as a separate item and is either part of an assembly/kit that can be purchased, or is not available for sale through Multiquip.

SUGGESTED SPARE PARTS

HDA-SERIES TROWEL 1 TO 3 UNITS WITH HONDA GX340K1QA2 AND GX390K1QA2 ENGINES.

1 to 3 Units

Qty.	P/N	Description
1	20478	GRIP, LEFT
1	20463	GRIP, RIGHT
2	20856	SAFETY SWITCH
1	20285	CABLE STANDARD HANDLE
1	20297	CABLE QUICK-PITCH™
1	20435	THROTTLE CABLE
4	1157 A	BUSHING
4	1162 A	LUBE CAP
4	1167 A	SCREW
4	1456	NUT
4	1875	WASHER
4	1322	SCREW
1	21046	GASKET KIT
1	21047	BEARING KIT
4	1247	RUBBER GROMMET
4	1245	SPACER
1	2827	ARM (16-1/2")
4	0261	BELT, A-31 GATES (HDA 11 HP)
2	11537	BELT, HOFFCO-COMET (HDA 13 HP)
1	10968	THRUST COLLAR KIT
2	9807955846	SPARK PLUG
2	17620ZH7023	TANK CAP
2	17210ZE2505	AIR CLEANER ELEMENT
2	17218ZE2505	FILTER OUTER

NAMEPLATE AND DECALS

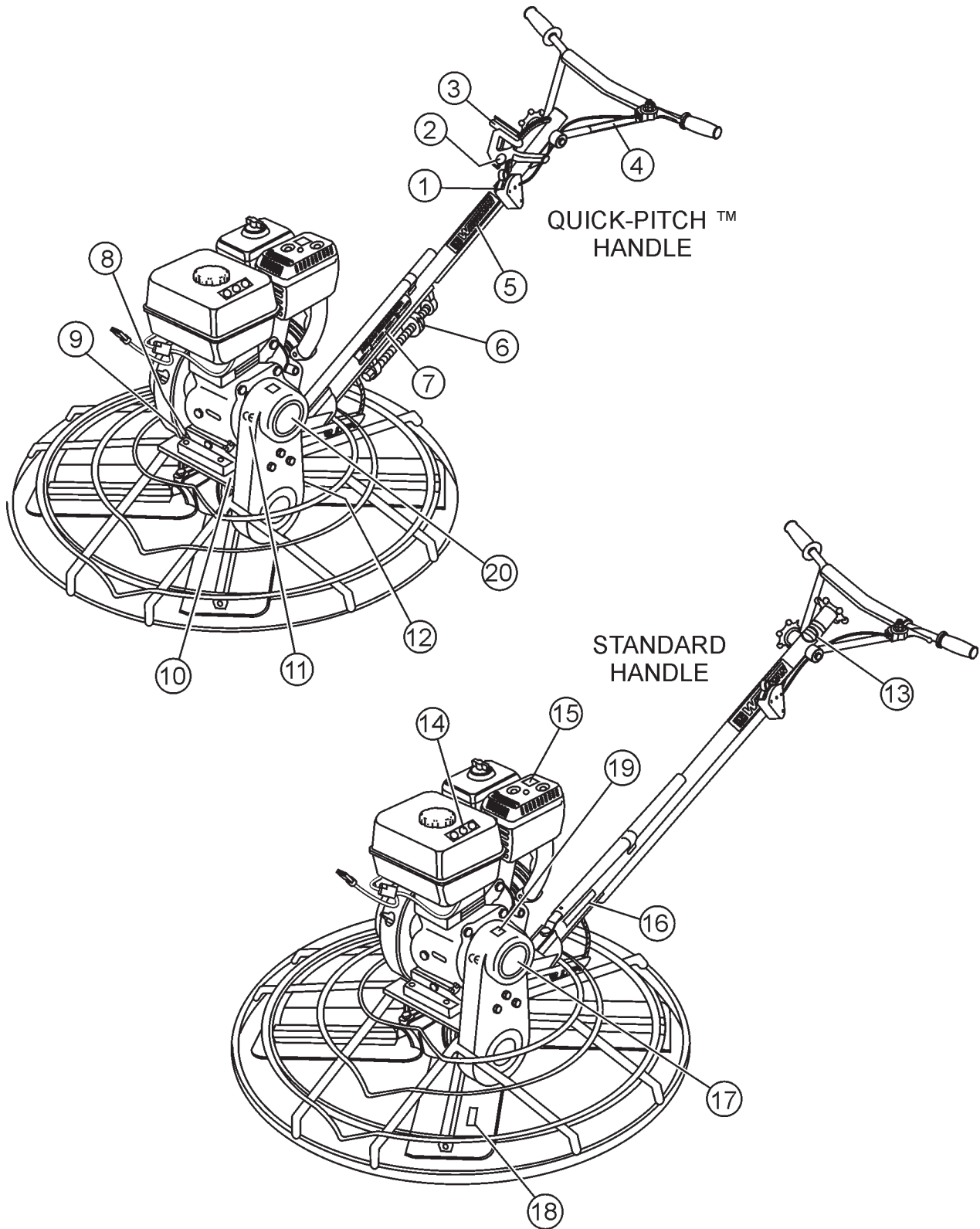

NAMEPLATE AND DECALS

<u>NO.</u>	<u>PART NO.</u>	<u>PART NAME</u>	<u>QTY.</u>	<u>REMARKS</u>
1	1758	DECAL: QUICK-PITCH™ HANDLE	1	
2	12405	DECAL: QUICK-PITCH™ HANDLE INSERT	2	
3	20527	DECAL: QUICK-PITCH™ WARNING	1	
4	20526	DECAL: QUICK-PITCH™ LATCH WARNING	1	
5	2942	DECAL: MQ WHITEMAN 13"	1	
6	1736	DECAL: ARROWS	1	
7	1735	DECAL: PRE-LOAD INDICATOR	1	
8	11246	DECAL: OIL CHECK	1	PART OF DECAL KIT P/N 12620
9		NAMEPLATE	1	CONTACT MULTIQUIP SERVICE DEPT.
10	1940	DECAL: MQ WHITEMAN (SMALL)	1	
11	11092	DECAL: CE	1	
12	11246	DECAL: GEAR DRIVE	1	PART OF DECAL KIT P/N 12620
13	1492	DECAL: STANDARD HANDLE (FINISHER)	1	
14	1147	DECAL: HELMET, FOOT AND GLOVE	1	PART OF DECAL KIT P/N 12620
15	11246	DECAL: HOT	1	PART OF DECAL KIT P/N 12620
16	1261	DECAL: DO NOT LIFT	1	
17	1848	DECAL: POWER TROWEL	1	
18	2938	DECAL: METRIC	1	
19	11246	DECAL: BELT DRIVE	1	PART OF DECAL KIT P/N 12620
20	2423	DECAL: MQ WHITEMAN-ENGINE	1	

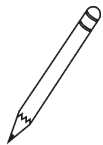
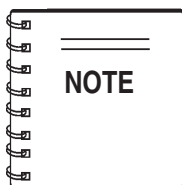

SEE DECAL ILLUSTRATIONS ON PAGE 12

STANDARD HANDLE ASSY. (OLD STYLE)

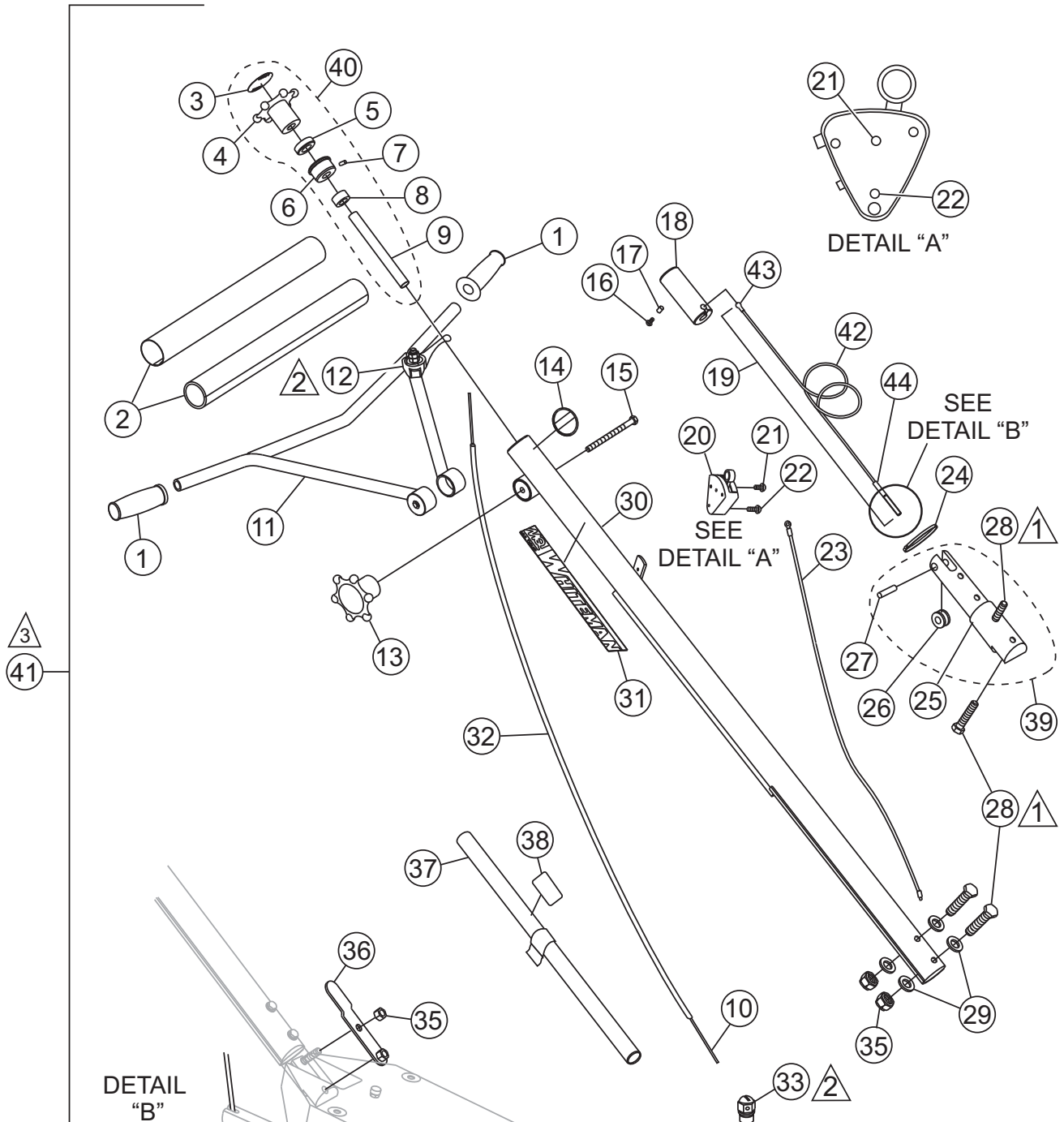

- ▲ 1 APPLY THREAD LOCK (LOCTITE 242 BLUE OR EQUIVALENT).
- ▲ 2 PART OF ENGINE ASSEMBLY.
- ▲ 3 COMPLETE HANDLE ASSY, P/N 20299 NO LONGER AVAILABLE. WHEN REPLACING ENTIRE ASSY, USE P/N 22258. SEE STANDARD HANDLE ASSY. (NEW STYLE)

STANDARD HANDLE ASSY. (OLD STYLE)

<u>NO.</u>	<u>PART NO.</u>	<u>PART NAME</u>	<u>QTY.</u>	<u>REMARKS</u>
1	20478	GRIP, HANDLE	2	
2	20774	COVER, PAD HANDLE	1	
3	20818	DECAL, STD PITCH.....	1	OBSOLETE ON LATER MODELS
4*	20817	WHEEL, HAND HANDLE	1	
5*	0281	BEARING, THRUST, NICE 607	1	
6*	20282	BEARING, TROWEL CONTROL	1	
7*	0122 C	SCREW, SHS 3/8-16 X 1/2	1	
8*	3615	COLLAR, SET 3/4 ID	1	
9*	1478	SHAFT, TROWEL CONTROL	1	
10	21172	CABLE, THROTTLE	1	
11	12556	HANDLE, ADJUSTABLE	1	
12	21171	THROTTLE	1	
13	20439	WHEEL ASSY., HAND	1	
14	1492	DECAL, CUSTOM 2 1/2 CHROME	1	
15	20438	SCREW, HHC 3/8-16 X 5.00	1	
16	0786	SCREW, BHC 1/4- 20 X 3/8 NYL PATCH, NP	1	
17	0786 A	SPACER, .360 X 17/64 X 1/8L	1	
18	20287	SLIDE BLOCK TROWEL CONTROL	1	
19	20285	CABLE ASSY., LENGTH 48.29" STD FINISHER	1	
20	20856	SWITCH ASSY., SAFETY STOP	1	INCLUDES ITEM W/%
21%	1602	SCREW, RHM 10-24 X 3/8"	1	
22	20988	SCREW, FHSC PHILLIPS 8-32 X 1 1/4	1	
23	20514	WIRE ASSY., SAFETY STOP SWITCH	1	
24	1662	TIE, CABLE TY-RAP, BLACK	1	
25#	20460	BLOCK, SUPPORT	1	
26#	1118	PULLEY, SUPPORT BLOCK	1	
27#	20279	PIN, SUPPORT BLOCK 3/8 X 1.59	1	
28	0169	SCREW, HHC 3/8-16 X 3	4	
29	10136	WASHER, FLAT 3/8 SAE	4	
30	12567	HANDLE, STD	1	
31	2942	DECAL, MQ WHITEMAN, 13"	1	
32	21173	HOUSING, CABLE 74"	1	
33	20845	SWIVEL, THROTTLE CABLE	1	
34	1116	NUT, BRASS JAM 5/16-18	2	
35	10133	NUT, NYLOC 3/8-16	3	
36	20392	BRACKET, LIFT TUBE	1	
37		HANDLE, LIFT ASSY.	1	NO LONGER AVAILABLE
38		DECAL, CAUTION, LIFT HANDLE	1	NO LONGER AVAILABLE
39	20461	BLOCK, CABLE ASSY.	1	INCLUDES ITEMS W/#
40	20819	HAND WHEEL ASSY., PITCH CONTROL	1	INCLUDES ITEMS W/*
41	20299	HANDLE ASSY., STD FINISHERS.	1	NO LONGER AVAILABLE
42	20301	CABLE, CNTL 5/32 GALV AIRCRAFT 46.03"	1	
43	20421	CLEVIS, BALL END CONTROL CABLE	1	
44	A8638	END-BOLT, CONTROL CABLE	1	

STANDARD HANDLE ASSY. (NEW STYLE)

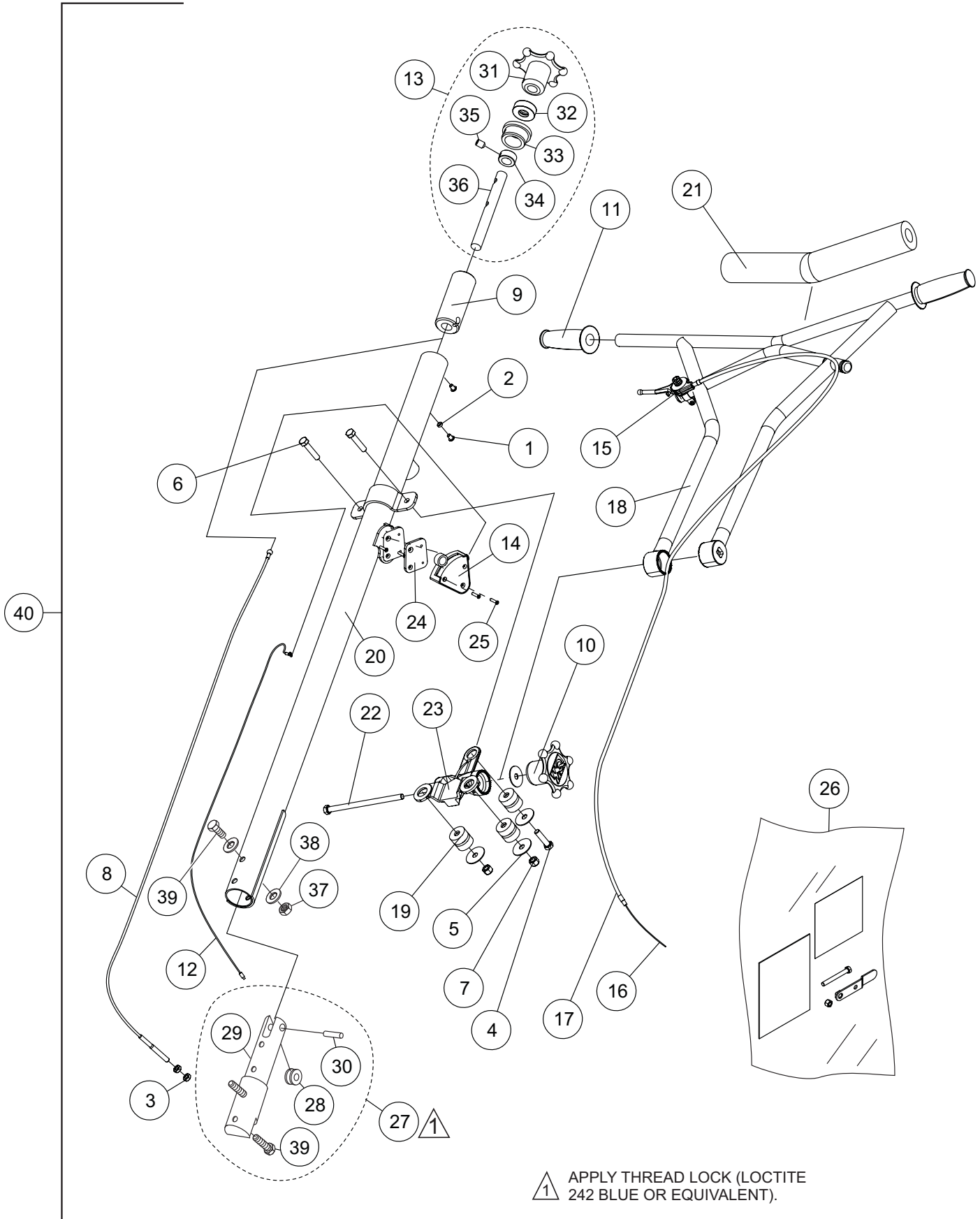

STANDARD HANDLE ASSY. (NEW STYLE)

<u>NO.</u>	<u>PART NO.</u>	<u>PART NAME</u>	<u>QTY.</u>	<u>REMARKS</u>
1%	0786	SCREW, BHC 1/4-20 X 3/8 NYL PATCH ,NP	2	
2%	0786A	SPACER, SLIDE BLOCK GUIDE	1	
3%	1116	NUT, BRASS JAM 5/16-18	2	
4%	1284	SCREW, HHC 3/8-16 X 1 1/2	1	
5%	3233	WASHER, FENDER, 1.5OD X 3/8ID	4	
6%	9154	SCREW, HHC 3/8-16 X 1 3/4	2	
7%	10133	NUT, NYLOC 3/8-16	2	
8%	20285	CABLE, CONTROL	1	
9%	20287	SLIDE BLOCK, TROWEL CONTROL	1	
10%	20439	WHEEL ASM. , HAND	1	
11%	20478	GRIP, HANDLE	2	
12%	20514	WIRE ASSY., KILL SWITCH	1	
13%	20819	HAND WHEEL ASSY, PITCH CONTROL	1	INCLUDES ITEMS W/\$
14%	20856	SWITCH ASM., KILL	1	
15%	21171	THROTTLE, BICYCLE FINISHER HANDLES	1	
16%	21172	CABLE, THROTTLE 68"	1	
17%	21173	HOUSING, MAGURA THROTTLE CABLES	1	
18%	22055	HANDLE WA, VIBRATION CONTROL	1	
19%	22059	ISOLATOR, VIBRATION 80 DUROMETER SHORE A	3	
20%	22095	HANDLE, W/A, STOW FIN VIBE CONTROL	1	
21%	22166	COVER,VIBE CONTROL HANDLE PAD	1	
22%	22167	SCREW, HHC 3/8-16 X 6.5" GRADE 5	1	
23%	22206	CHASSIS, CAST VIBRATION ISOLATOR	1	
24%	22256	BRACKET, HD KILLSWITCH MOUNT	2	
25%	22263	SCREW, PHILLIPS HEAD MACHINE 8-32 X .75	4	
26%	22226	KIT, INSTALLATION VIBE CONTROL HANDLE	1	INCLUDES ITEMS W/@
27%@	20461	BLOCK, CABLE ASSY.	1	INCLUDES ITEMS W/#
28%#@	1118	PULLEY, SUPPORT BLOCK	1	
29%#@	20460	BLOCK, SUPPORT	1	
30%#@	20279	PIN, SUPPORT BLOCK 3/8 X 1.59	1	
31%\$	20817	WHEEL, HAND HANDLE	1	
32%\$	0281	BEARING, THRUST, NICE 607	1	
33%\$	20282	BEARING, TROWEL CONTROL	1	
34%\$	3615	COLLAR, SET 3/4 ID	1	
35%\$	0122 C	SCREW, SHS 3/8-16 X 1/2	1	
36%\$	1478	SHAFT, TROWEL CONTROL	1	
37%@	10133	NUT, NYLOC 3/8-16	2	
38%@	10136	WASHER, FLAT 3/8 SAE	4	
39%@	0169	SCREW, HHC 3/8-16 X 3	4	
40	22258	HANDLE ASSY, SXH HD	1	INCLUDES ITEMS W/%

QUICK-PITCH™ HANDLE ASSY. (OLD STYLE)

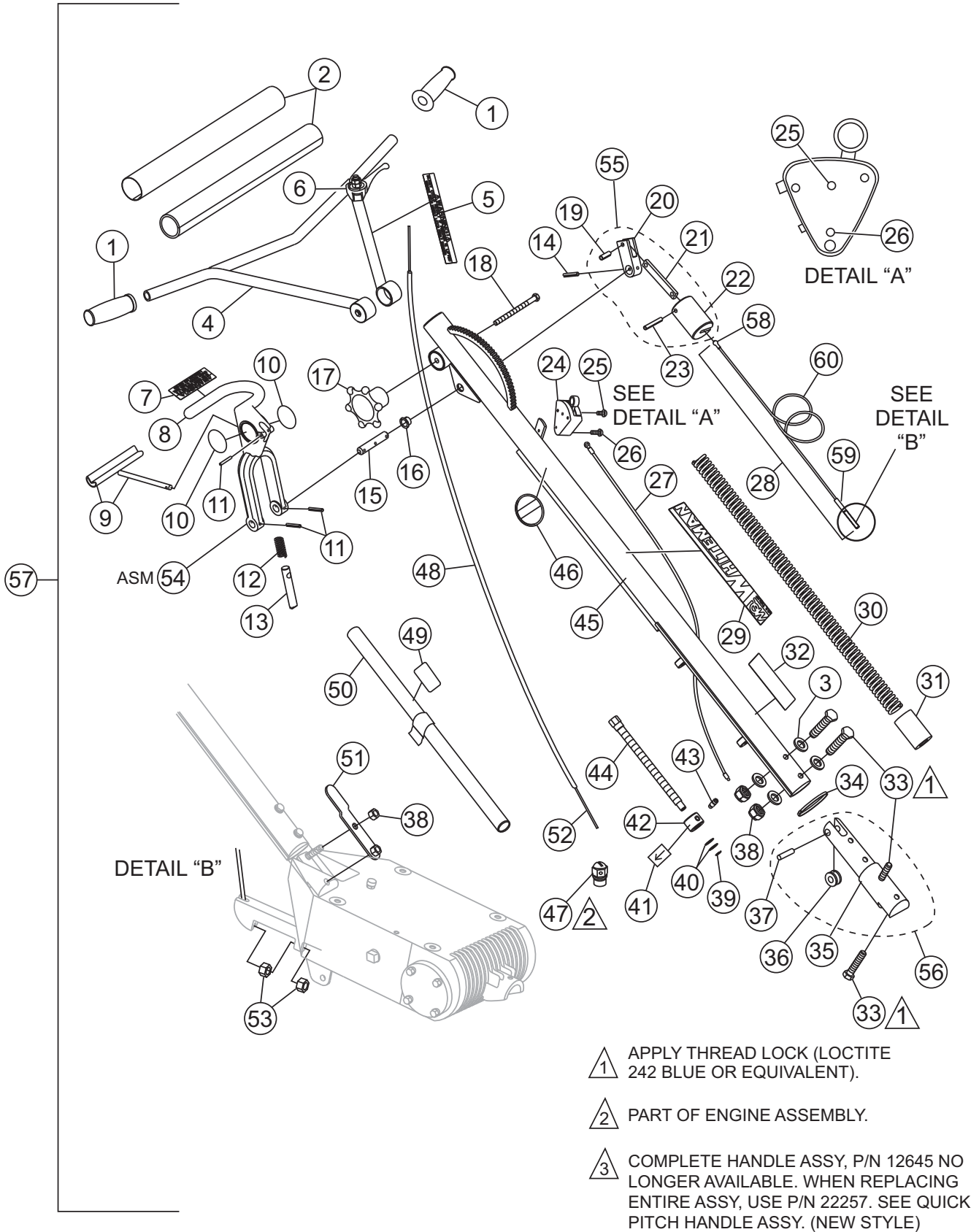

QUICK-PITCH™ HANDLE ASSY. (OLD STYLE)

<u>NO.</u>	<u>PART NO.</u>	<u>PART NAME</u>	<u>QTY.</u>	<u>REMARKS</u>
1	20478	GRIP, HANDLE	2	
2	20774	COVER, PAD HANDLE	1	
3	10136	WASHER, FLAT 3/8 SAE	4	
4	12556	HANDLE, ADJUSTABLE	1	
5	20526	DECAL, LATCH WARNING	1	
6	21171	THROTTLE	1	
7	20527	DECAL, Q.P. WARNING	1	
8*	20389	HANDLE, QUICK-PITCH™	1	
9*	1746	TRIGGER, QP CHROMED	1	
10*	12405	DECAL, WHITEMAN QUICK-PITCH™	2	
11	1729	PIN, ROLL 3/16 X 1 1/4	3	
12*	1706	SPRING, ENCLOSED QP CLAMP	1	
13*	20437	PIN, QP LATCH	1	
14	4568	PIN, ROLL 3/16 X 1	1	
15	1711	SHAFT, CONTROL QP	1	
16	1719	BUSHING, PIVOT PLATE	1	
17	20439	WHEEL ASSY., HAND	1	
18	20438	SCREW, HHC 3/8-16 X 5.00	1	
19+	1731	PIN, ROLL 1/4 X 3/4	1	
20+	20443	ARM, SLIDE CONTROL	1	
21+	1709	CONNECTOR, QP CONTROL ARM	1	
22+	20269	LINKAGE, QP CONTROL	1	
23+	20276	PIN, ROLL 1/4 X 1 3/4	1	
24	20856	SWITCH ASSY., SAFETY STOP	1	INCLUDES ITEM W/*
25*	1602	SCREW, RHM 10-24 X 3/8	1	
26	20988	SCREW, FHSC PHILLIPS 8-32 X 1 1/4	1	
27	20514	WIRE ASSY., SAFETY STOP SWITCH	1	
28	20297	CABLE ASSY., QP CONTROL, 45"	1	
29	2942	DECAL, MQ WHITEMAN, 13"	1	
30	1715	SPRING, COUNTER BALANCE	1	
31	20270	BLOCK, QP ADJUSTMENT	1	
32	1735	DECAL, PRELOAD TRIM INDICATOR	1	
33	0169	SCREW, HHC 3/8-16 X 3	4	
34	1662	TIE, CABLE, TY-RAP BLACK	1	
35#	20460	BLOCK, SUPPORT	1	
36#	1118	PULLEY, SUPPORT BLOCK	1	
37#	20279	PIN, SUPPORT BLOCK 3/8 X 1.59	1	
38	10133	NUT, NYLOC 3/8-16	3	
39	1737	SNAP RING, TRUARC #5100-50	1	
40	1733	WASHER, 1/2 X 1/32, HARDENED	2	

QUICK-PITCH™ HANDLE ASSY. (OLD STYLE)

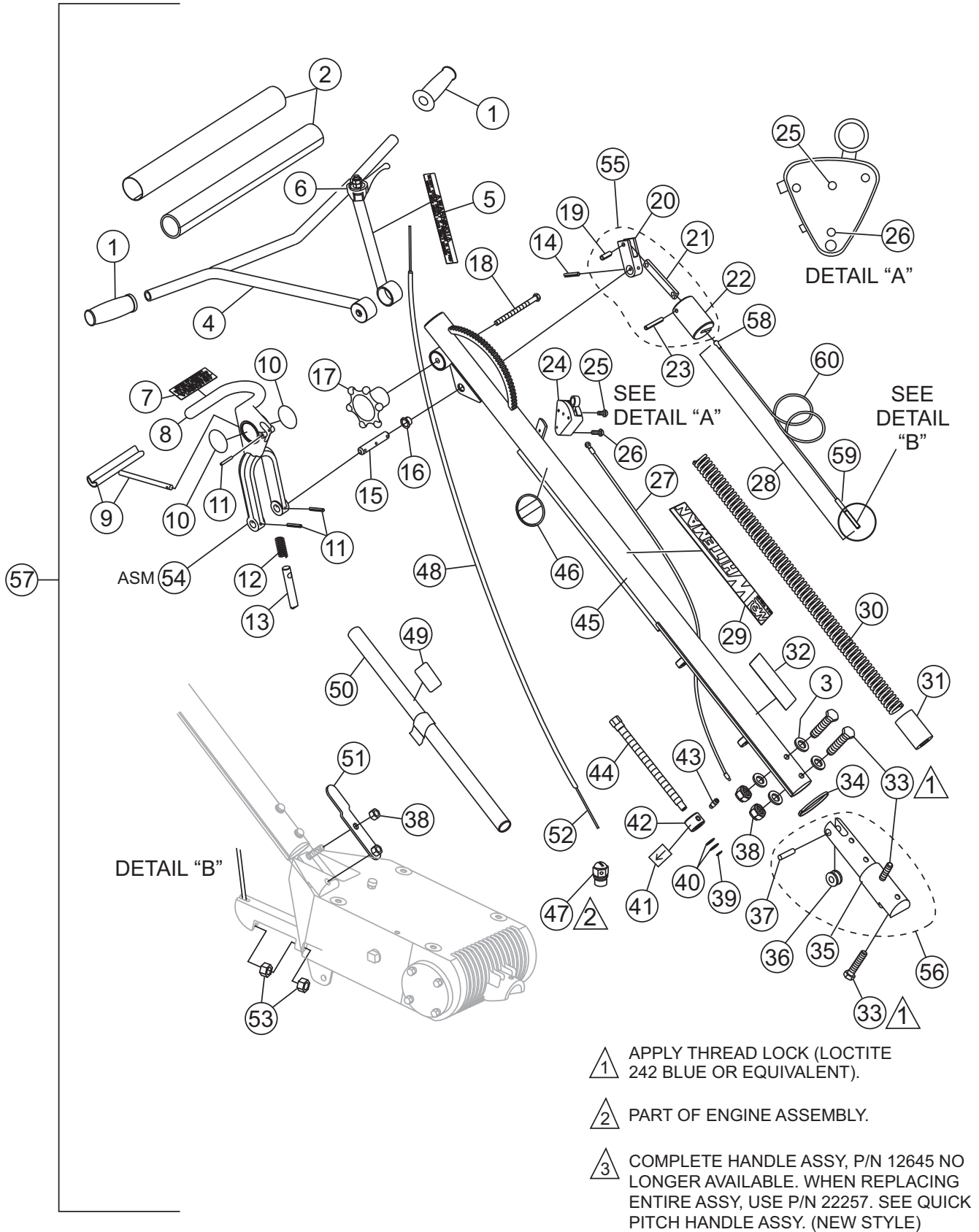

QUICK-PITCH™ HANDLE ASSY. (OLD STYLE)

<u>NO.</u>	<u>PART NO.</u>	<u>PART NAME</u>	<u>QTY.</u>	<u>REMARKS</u>
41	1736	DECAL, ARROW	1	
42	1718	NUT, QP TRIM CONTROL ADJUST	1	
43	1732	BOLT, STRIPPER 3/8 X 1/2	1	
44	1717	SCREW, QP TRIM ADJUSTMENT	1	
45	12642	TUBE, MAIN HANDLE	1	
46	1758	DECAL, PATENT QP	1	
47	20845	SWIVEL, ENGINE THROTTLE CABLE	1	
48	21173	HOUSING, THROTTLE CABLE 74"	1	
49		DECAL, CAUTION, LIFT HANDLE	1	NO LONGER AVAILABLE
50		HANDLE, LIFT ASSY.	1	NO LONGER AVAILABLE
51	20392	BRACKET, LIFT TUBE	1	
52	21172	CABLE, THROTTLE	1	
53	1116	NUT, BRASS JAM 5/16-18	2	
54	20390	TRIGGER, QP ASSY.	1	INCLUDES ITEMS W/*
55	20293	LINKAGE, QP CONTROL ASSY.	1	INCLUDES ITEMS W/+
56	20461	BLOCK, CABLE ASSY.	1	INCLUDES ITEMS W/#
57	12645	HANDLE ASSY., MAIN	1	NO LONGER AVAILABLE
58	20421	CLEVIS, BALL END CONTROL CABLE	1	
59	A8638	END-BOLT, CONTROL CABLE	1	
60	20297	CABLE, CNTL 5/32 GALV AIRCRAFT 43.19"	1	

QUICK-PITCH™ HANDLE ASSY. (NEW STYLE)

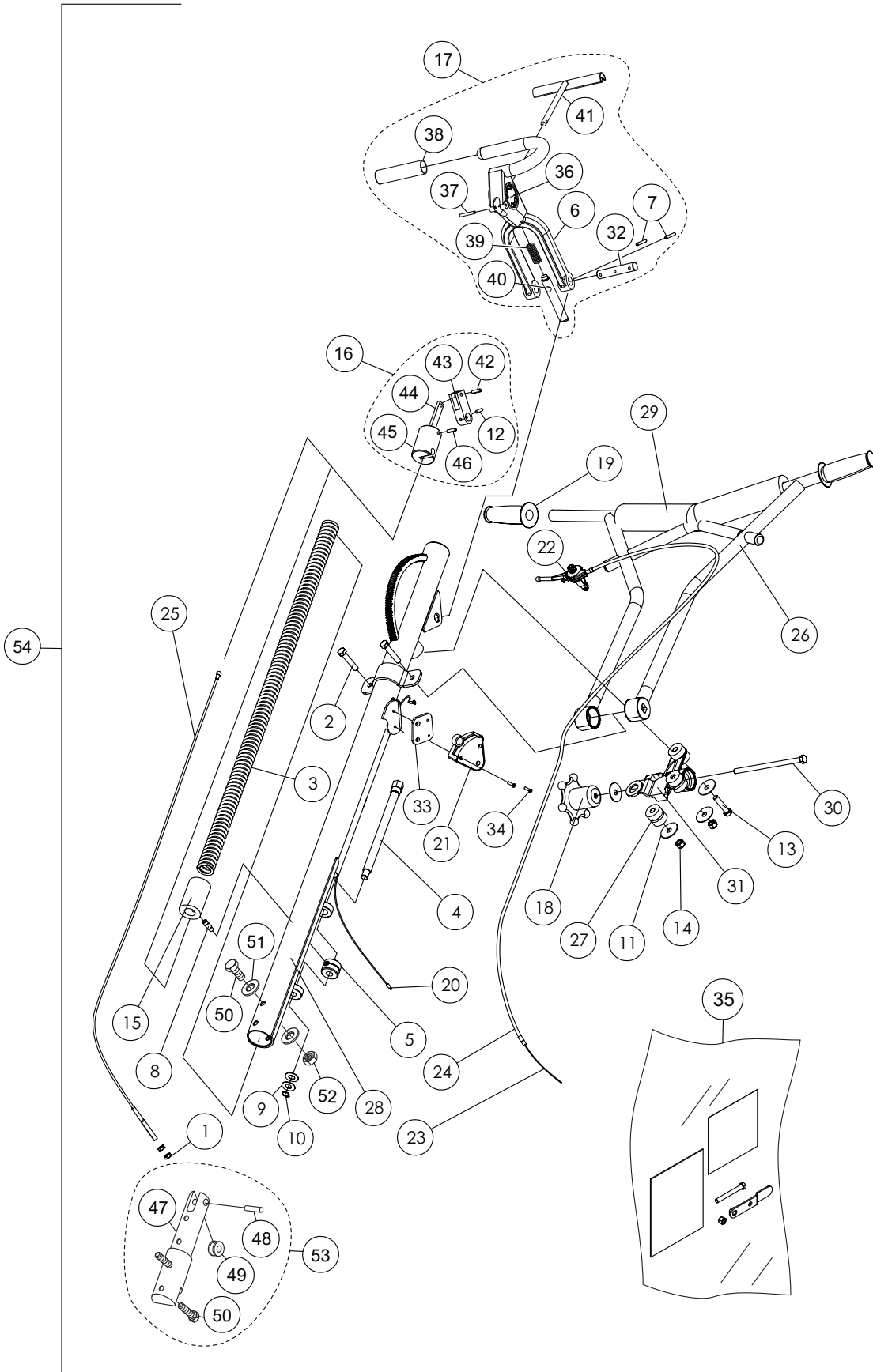

QUICK-PITCH™ HANDLE ASSY. (NEW STYLE)

<u>NO.</u>	<u>PART NO.</u>	<u>PART NAME</u>	<u>QTY.</u>	<u>REMARKS</u>
1%	1116	NUT, BRASS JAM 5/16-18	2	
2%	1665	SCREW, HHC 3/8-16 X 2	2	
3%	1715	Q.P. SPRING CENTER BALANCE	1	
4%	1717	SCREW, QP TRIM ADJUSTMENT W/A	1	
5%	1718	NUT , QP TRIM CNTL ADJUSTMENT	1	
6%@	20389	HANDLE, QP	1	
7%@	1729	PIN, ROLL 3/16 X 1-1/4	2	
8%	1732	Q.P. ADJUSTMENT PIN	1	
9%	1733	WASHER, 1/2 X 1/32, AN960-816L	2	
10%	1737	RING, SNAP, TRUARC 5100-50	1	
11%	3233	WASHER, FENDER, 1.5OD X 3/8ID	4	
12%#	4568	PIN, ROLL 3/16 x 1	1	
13%	9154	SCREW, HHC 3/8-16 X 1 3/4	1	
14%	10133	NUT, NYLOC 3/8-16	2	
15%	20270	QP ADJUSTMENT BLOCK	1	
16%	20293	LINKAGE QP CONTROL	1	INCLUDES ITEMS W/#
17%	20390	TRIGGER, QP ASSEMBLY	1	INCLUDES ITEMS W/@
18%	20439	WHEEL ASM. , HAND	1	
19%	20478	GRIP, HANDLE	2	
20%	20514	WIRE ASSY., KILL SWITCH	1	
21%	20856	SWITCH ASM., KILL	1	
22%	21171	THROTTLE, BICYCLE FINISHER HANDLES	1	
23%	21172	CABLE, THROTTLE 68"	1	
24%	21173	HOUSING, MAGURA THROTTLE CABLES	1	
25%	20297	CABLE ASM, LENGTH 45", JB, HD & QP	1	
26%	22055	HANDLE WA, VIBRATION CONTROL	1	
27%	22059	ISOLATOR, VIBRATION 80 DUROMETER SHORE A	3	
28%	22060	MAIN HANDLE WA, QUICK PITCH VIBE CONTROL	1	
29%	22166	COVER, VIBE CONTROL HANDLE PAD	1	
30%	22167	SCREW, HHC 3/8-16 X 6.5" GRADE 5	1	
31%	22206	CHASSIS, CAST VIBRATION ISOLATOR	1	
32%@	1711	SHAFT, CONTROL Q.P.	1	
33%	22256	BRACKET, HD KILLSWITCH MOUNT	1	
34%	22263	SCREW, PHILLIPS HEAD MACHINE 8-32 X .75	2	
35%	22226	KIT, INSTALLATION VIBE CONTROL HANDLE	1	INCLUDES ITEMS W/\$
36%@	12405	DECAL, WHITEMAN QUICK PITCH	2	
37%@	1729	PIN, ROLL 3/16 X 1-1/4	1	
38%@	1724	GRIP, HANDLE	1	
39%@	1706	SPRING, COMPRESSION	1	
40%@	20437	PIN, QP LATCH	1	
41%@	A6581	TRIGGER, QP	1	
42%#	1731	PIN, ROLL 1/4 X 3/4	1	
43%#	20443	ARM, SLIDE CONTROL	1	
44%#	1709	QP DOGBONE	1	
45%#	20269	BLOCK, CABLE SLIDE	1	
46%#	20276	PIN, ROLL 1/4 X 1-3/4	1	
47%\$\$	22095	HANDLE, W/A, STOW FIN VIBE CONTROL	1	
48%\$\$	20279	PIN, SUPPORT BLOCK 3/8 X 1.59	1	
49%\$\$	1118	PULLEY, SUPPORT BLOCK	1	
50%\$\$	0169	SCREW, HHC 3/8-16 X 3	4	
51%\$	10136	WASHER, FLAT 3/8 SAE	4	
52%\$	10133	NUT, NYLOC 3/8-16	2	
53%\$	20461	BLOCK, CABLE ASSY.	1	INCLUDES ITEMS W/&
54	22257	HANDLE ASSY, QXH HD	1	INCLUDES ITEMS W/%

4-BLADE SPIDER ASSY.

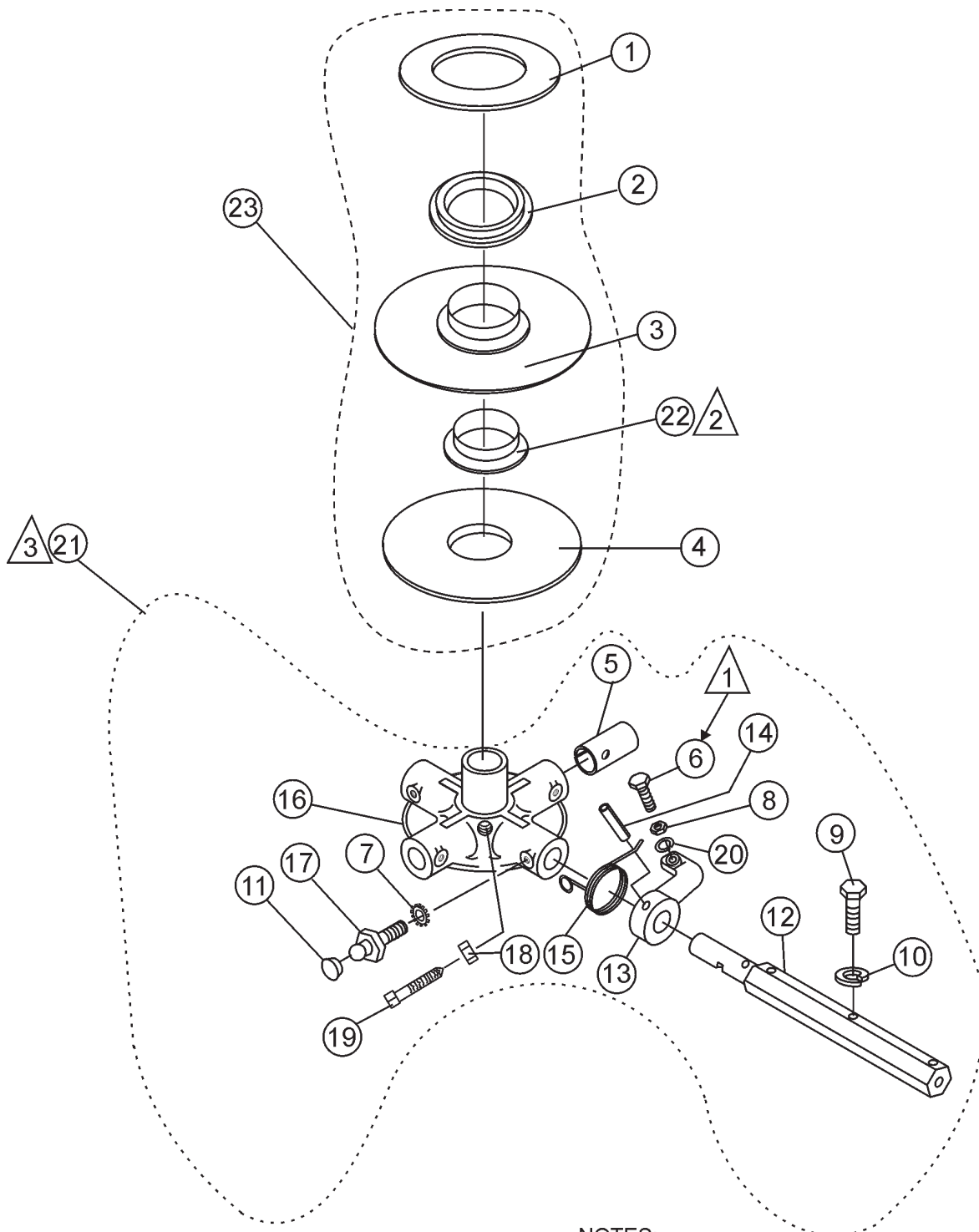

NOTES:

- △ 1 APPLY LOCTITE P/N 1477
- △ 2 INCLUDED WITH ITEM 3 OR CAN BE ORDERED SEPARATELY (P/N 1471).
- △ 3 SPIDER ASSEMBLY P/N 1215 INCLUDES ALL ITEMS WITHIN OUTLINE.

4-BLADE SPIDER ASSY.

<u>NO.</u>	<u>PART NO.</u>	<u>PART NAME</u>	<u>QTY.</u>	<u>REMARKS</u>
1*	12208	WEAR RING	1	
2*	12778	FLANGE BEARING	1	
3*	10816	THRUST COLLAR	1	INCLUDES ITEMS W/#
4*	9009	WEAR PLATE	1	
5%	11039	BUSHING	4	
6%	0164 B	RADIUS HEAD 3/8- 16 x 1-1/4"	4	
7%	1875	INT. SHKP. WASHER 3/8"	4	
8%	1876	JAM NUT 3/8- 16	4	
9%	0105	HHCS 5/16- 18 x 1-1/2"	8	
10%	0161 C	LOCK WASHER 5/16"	8	
11%	1162 A	LUBRA-CAP	4	
12%	2829	ARM 17" LONG	4	
13%	9005	TROWEL ARM LEVER	4	
14%	4164	ROLL PIN 5/16 x 1-3/4"	4	
15%	9111	SPRING (RIGHT HAND)	4	
16%	11778	SPIDER PLATE ONLY	1	
17%	1322	RETAINING SCREW ASSY.	4	
18%	1456	HEX NUT 3/8-16	1	
19%	1167 A	SHSS 3/8-16 x 1-1/2" CONE POINT	1	
20%	0166 A	LOCK WASHER 3/8"	4	
21	9150	SPIDER PLATE ASSY.	1	INCLUDES ITEMS W/%
22*#	1471	THRUST COLLAR BUSHING	1	
23	10969	THRUST BEARING KIT	1	INCLUDES ITEMS W/*

GEARBOX & ENGINE MOUNTS ASSY.

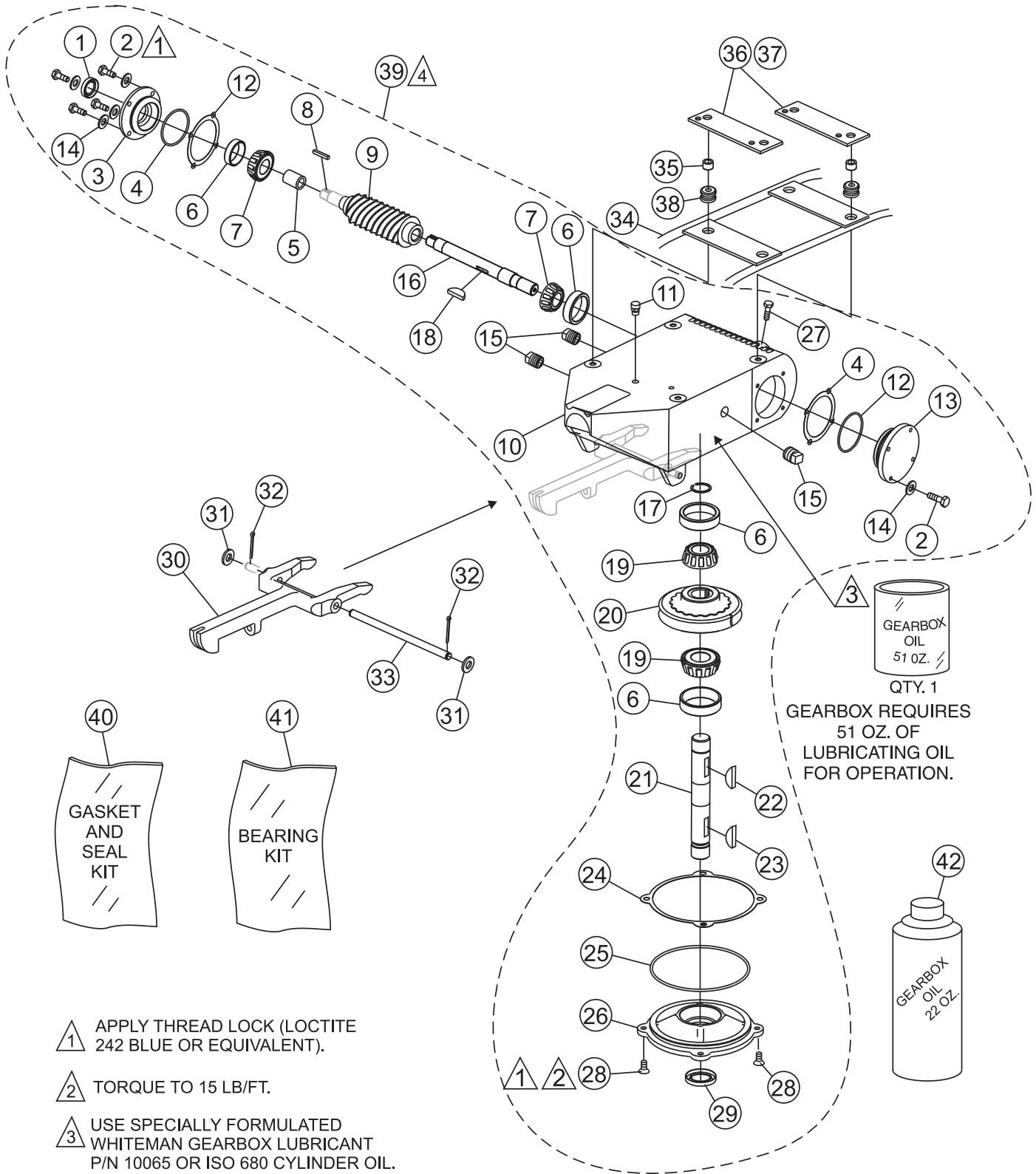

QTY. 1
 GEARBOX REQUIRES
 51 OZ. OF
 LUBRICATING OIL
 FOR OPERATION.

- 1 △ APPLY THREAD LOCK (LOCTITE 242 BLUE OR EQUIVALENT).
- 2 △ TORQUE TO 15 LB/FT.
- 3 △ USE SPECIALLY FORMULATED WHITEMAN GEARBOX LUBRICANT P/N 10065 OR ISO 680 CYLINDER OIL.
- 4 △ GEARBOX ASSEMBLY, ITEM 39 INCLUDES ITEMS WITHIN DASHED LINES, EXCEPT ITEMS 12 AND 23.

GEARBOX & ENGINE MOUNTS ASSY.

<u>NO.</u>	<u>PART NO.</u>	<u>PART NAME</u>	<u>QTY.</u>	<u>REMARKS</u>
1%*	12909	SEAL, OIL TCM 10172VTB-H	1	
2%	2295	SCREW, HHC 1/4-20 X 7/8	8	
3%	9047	FLANGE, COUNTERSHAFT	1	
4%*	2309	O-RING, 2-13/16" VITON	2	
5%*	12583	SPACER, 1.38OD X 1.06 X 1.168L	1	
6%#	232 A	BEARING, CUP, TIMKEN 1932	4	
7%#	9045	BEARING, CONE, TIMKEN 1986	2	
8%	1580	KEY, SQUARE	1	
9%	12908	GEAR, WORM RH	1	
10%	20540	CASE, HD GEARBOX 2" HANDLE	1	
11%	1132	VENT, AIR	1	
12	9048	GASKET	2	
13%	9046	CAP, END	1	
14%	10031	WASHER, EXT. SHKP	8	
15%	0121 A	FITTING, PLUG 3/8 MP SQ HEAD	3	
16%	12944	SHAFT, GEARBOX (13 HP HONDA)	1	
16%	12943	SHAFT, GEARBOX (11 HP HONDA)	1	
17%	1138	RING, SNAP, TRUARC 5100-112	1	
18%#	1139	KEY, WOODRUFF	1	
19%#	232	BEARING, CONE TIMKEN 1985	2	
20%	9181	GEAR, WORM, RH	1	
21%	9179	SHAFT, MAIN OUTPUT HD 48	1	
22%	9180	KEY, 5/16 X 2- 1/4 H	1	
23	1238	KEY, WOODRUFF #25	1	
24%*	9037	SHIM, OUTPUT	1	
25%*	9038	O-RING, A-257 VITON	1	
26%	9036	COVER, GEARBOX	1	
27%	0400 B	SCREW, HHC 5/16 - 18 X 1/2	1	
28%	20875	SCREW, FHSC 5/16-18 X 3/4	4	
29%*	9041	SEAL, OIL, TCM	1	
30	9027	ARM, YOKE	1	
31	10136	WASHER, FLAT 3/8 SAE	4	
32	0683	PIN, COTTER 3/32	2	
33	9028	PIN, YOKE	1	
34	7299	STATIONARY GUARD RING	1	
35	1245	SPACER, GUARD RING	4	
36	1951	PLATE, ENGINE MOUNT (11 HP HONDA)	2	
37	11541	PLATE, ENGINE MOUNT (13 HP HONDA)	2	
38	1247	GROMMET 1/4 X .875 ID X 1-5/8 OD	4	
39	20879	GEARBOX ASSY. (11 HP HONDA)	1	INCLUDES ITEMS W/%
39	20882	GEARBOX ASSY. (13 HP HONDA)	1	INCLUDES ITEMS W/%
40	2618	GASKET/SEAL KIT	1	INCLUDES ITEMS W/*
41	2619	BEARING KIT.....	1.....	INCLUDES ITEMS W/#.
42	10139	LUBRICANT, GEARBOX, 22 OZ. BOTTLE	1	

ENGINE, 11 HP HONDA ASSY.

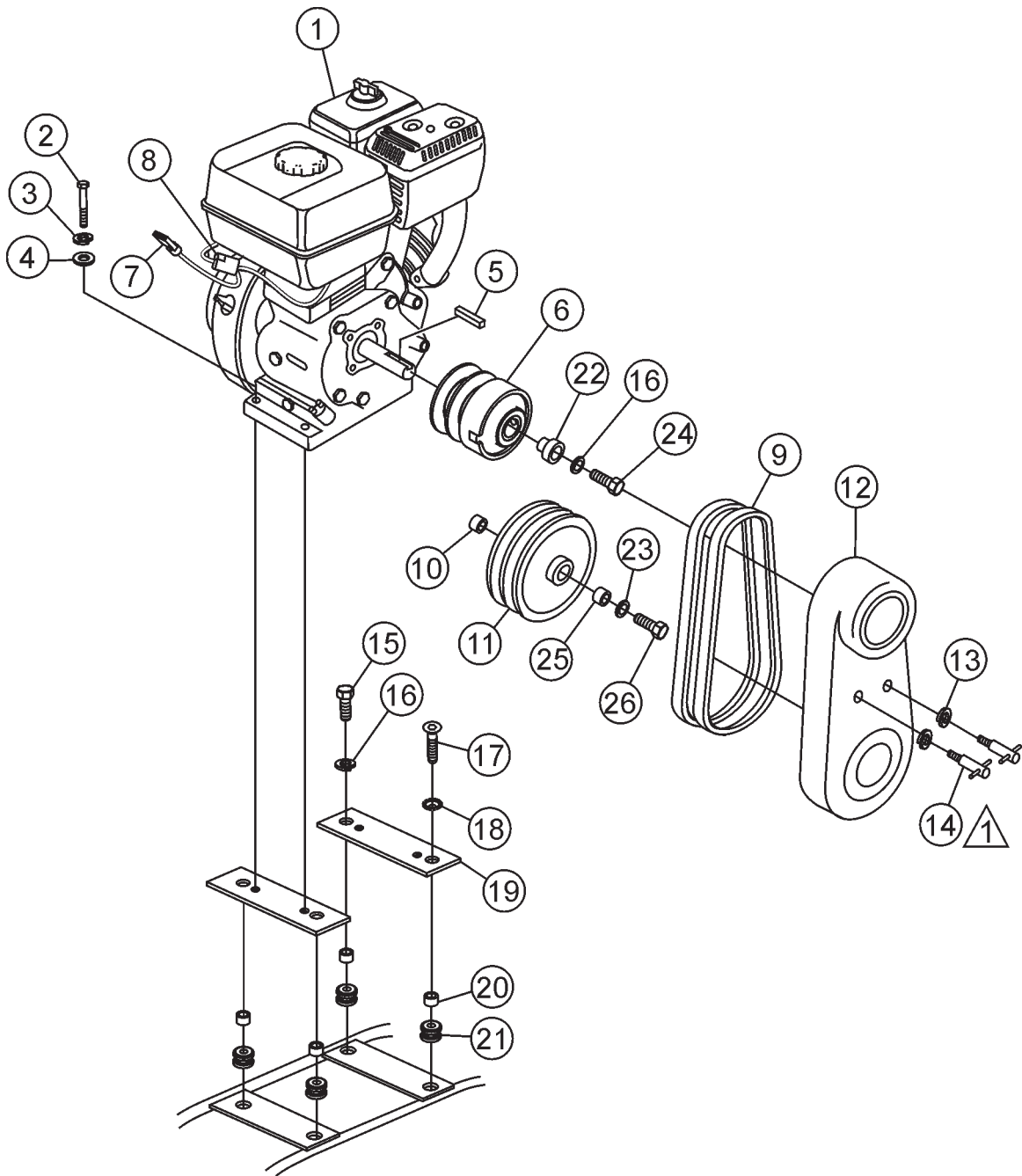

②⑦ LIFT STRAP-
CONTACT UNIT SALES DEPT./ACC. ITEM

△ ATTACHES TO LIFT BAIL BRACKET

ENGINE, 11 HP HONDA ASSY.

<u>NO.</u>	<u>PART NO.</u>	<u>PART NAME</u>	<u>QTY.</u>	<u>REMARKS</u>
1	1388	ENGINE 11 HP HONDA	1	
2	1391	HHCS 5/16-24 x 1-1/2"	4	
3	0161 C	LOCK WASHER 5/16"	4	
4	0300 B	FLAT WASHER 5/16"	4	
5	0310	SQUARE KEY 1/4X1/4X1.1/2"	1	
6	2480	CLUTCH, 4" P-G 35 DEGREE 1"	1	
7	1488	WIRE, SAFETY SWITCH	1	
8	1475	CONNECTOR, SPLICE TAP	1	
9	0261	BELT, A31 GATES HPII ONLY	2	
10	2362	SPACER, 1-1/4 X .878 X .375I	1	
11	9119	PULLEY, HD48 2AK54X7/8	1	
12	10222	GUARD, BELT	1	
13	10136	LOCK WASHER 1/4"	2	
14	2724	T-BOLT	2	
15	9154	SCREW, HHC 3/8 - 16 X 1-3/4	2	
16	0166 A	WASHER, LOCK 3/8 MED	3	
17	20982	SCREW, FSCS 3/8 - 16 X 1-1/2 PLTD	2	
18	1480	WASHER, CS EXT. SHKP 3/8	2	
19	1951	PLATE, FRONT, 11HP HONDA	2	
20	1245	BUSHING, GUARD RING	4	
21	1247	GROMMET, 1/4 X 7/8ID X 1-5/8OD	4	
22	9123	RETAINER, CLUTCH	1	
23	9120	RETAINER, DRIVEN PULLEY	1	
24	0478	SCREW, HHC 3/8 -24 X 2-1/4	1	
25	2361	SPACER, 1-1/4 X .878 X .437L	1	
26	1313	SCREW, FHSC 3/8 - 24 X 3/4 PLAIN	1	
27		LIFT STRAP	1	CONTACT UNIT SALES DEPT./ACC. ITEM

ENGINE, 13 HP HONDA ASSY.

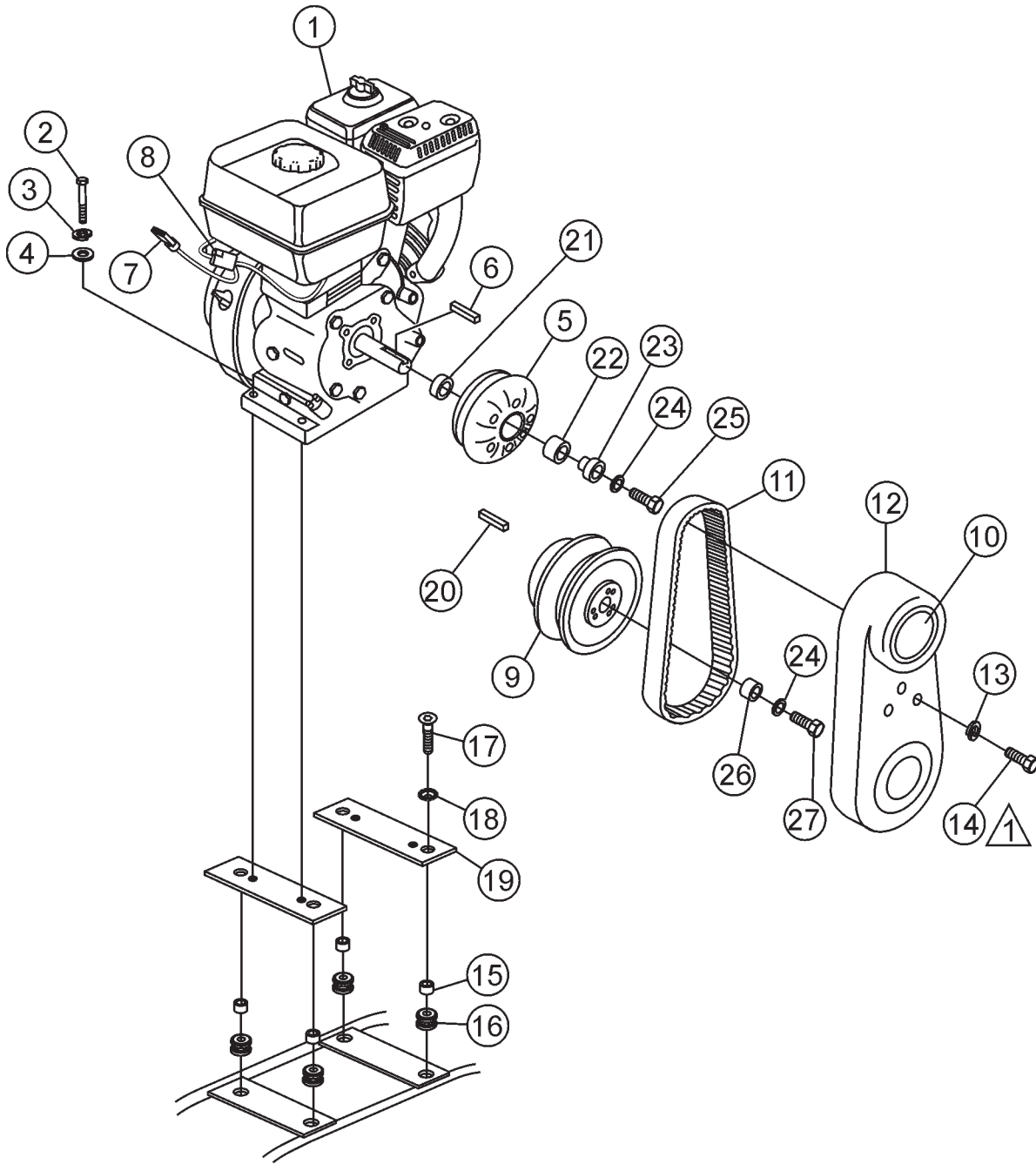

②⑧ LIFT STRAP-
CONTACT UNIT SALES DEPT./ACC. ITEM

⚠ 1 ATTACHES TO LIFT BAIL BRACKET

ENGINE, 13 HP HONDA ASSY.

<u>NO.</u>	<u>PART NO.</u>	<u>PART NAME</u>	<u>QTY.</u>	<u>REMARKS</u>
1	3364	ENGINE 13HP HONDA	1	
2	1391	HHCS 5/16-24 x 1-1/2"	4	
3	0161 C	LOCK WASHER 5/16"	4	
4	0300 B	FLAT WASHER 5/16"	4	
5	11535	CLUTCH, COMET 302353C	1	INCLUDES ITEM W/%
6%	1304	SQUARE KEY	1	
7	1488	WIRE, SAFETY SWITCH	1	
8	1475	CONNECTOR, SPLICE TAP	1	
9	11536	PULLEY, HOFFCO COMET 302358C	1	INCLUDES ITEM W/#
10	1848	DECAL, BELT GUARD	1	
11	11537	BELT, HOFFCO COMET #704041	1	
12	11440	GUARD, BELT	1	
13	0948	WASHER, FLAT 1/4" SAE	3	
14	0131 A	SCREW 1/4 - 20 X 3/4	3	
15	1245	BUSHING, GUARD RING	4	
16	1247	GROMMET, 1/4 X 7/8ID X 1-5/8OD	4	
17	20982	SCREW, FSCS 3/8 - 16 X 1-1/2 PLTD	4	
18	1480	WASHER, CS EXT. SHKP 3/8	4	
19	11541	PLATE, ENGINE MOUNT 13HP HONDA	2	
20#	1580	SQUARE KEY	1	
21	11543	SPACER, CLUTCH	1	
22	11560	SPACER, KEY RETAINER	1	
23	9123	RETAINER, CLUTCH	1	
24	0166 A	WASHER, LOCK 3/8 MED	2	
25	12921	SCREW, HHC, 3/8 - 24 X 3 GRD 8 PLTD	1	
26	11154	RETAINER, CENTRIFUGAL CLUTCH	1	
27	1672	SCREW, HHC 3/8 - 24 X 1	1	
28		LIFT STRAP	1	CONTACT UNIT SALES DEPT./ACC. ITEM

GUARD RING ASSY.

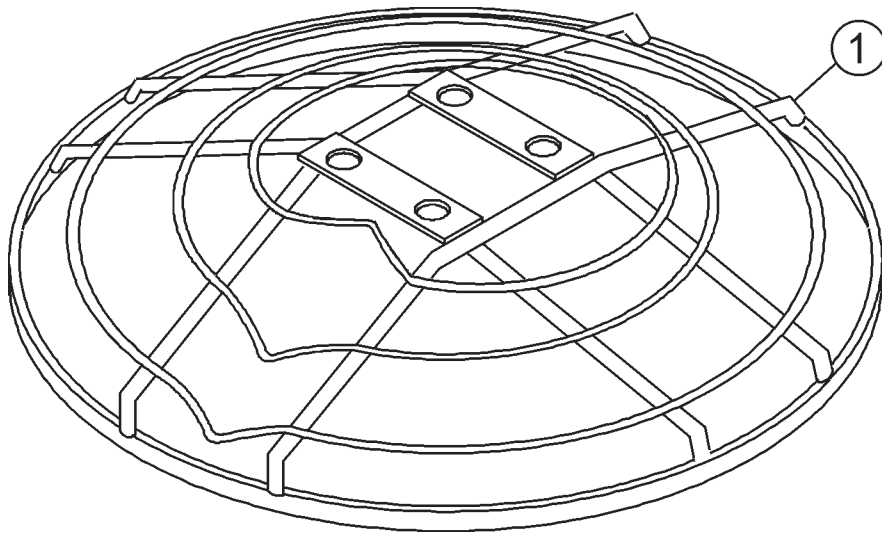

GUARD RING ASSY.

<u>NO.</u>	<u>PART NO.</u>	<u>PART NAME</u>	<u>QTY.</u>	<u>REMARKS</u>
1	9178	GUARD RING ASSEMBLY	1	

STABILIZER RING ASSY.

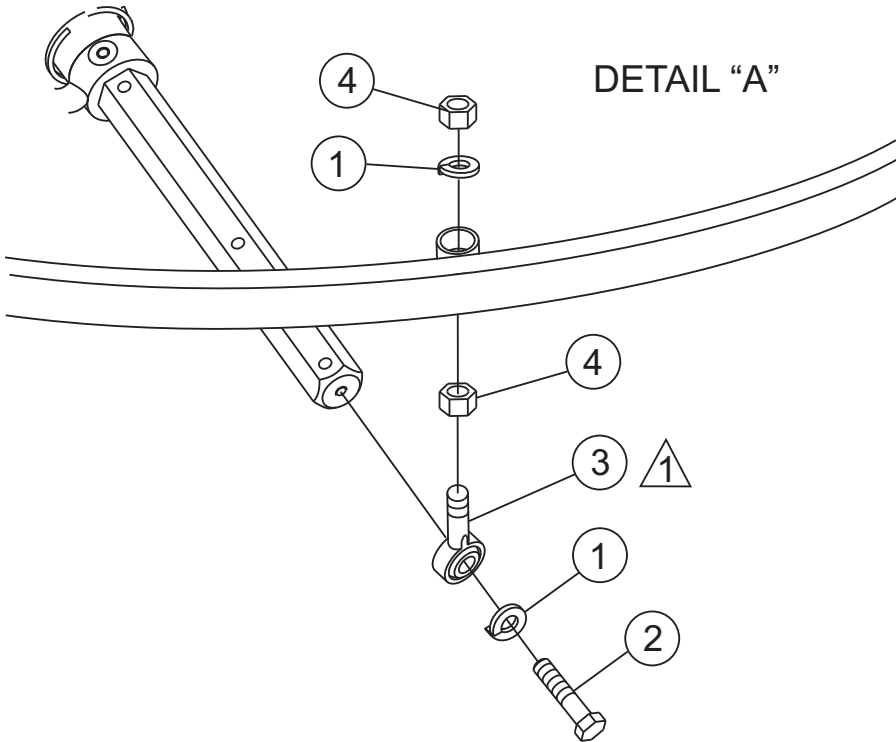
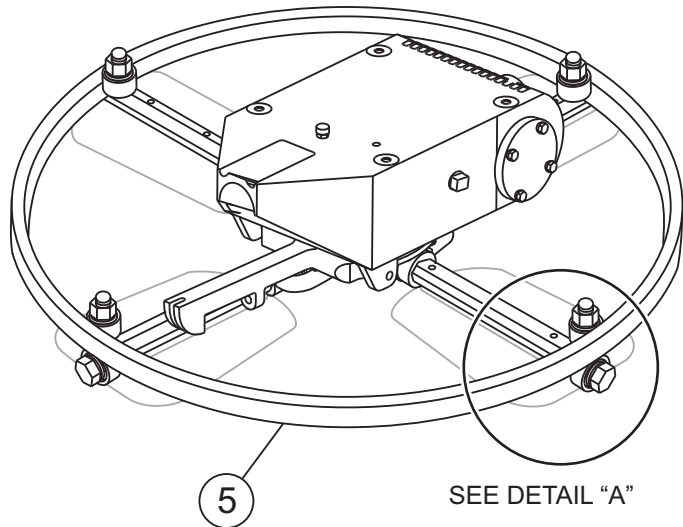

1 APPLY LOCTITE 242 BLUE OR EQUIVALENT.

STABILIZER RING ASSY.

<u>NO</u>	<u>PART NO</u>	<u>PART NAME</u>	<u>QTY.</u>	<u>REMARKS</u>
1	0161 C	WASHER, LOCK, 5/16 MED	8	
2	1237	SCREW, SCH 5/16-18 X 7/8, NYL, NP	4	
3	1723	ROD END, 5/16-24 MALE	4	
4	6014 C	NUT, HEX FINISH 5/16-24	8	
5	7311	RING, STABILIZER, HD-4	1	

BLADES & ARM ADJ. FIXTURE ASSY. (OPTIONS)

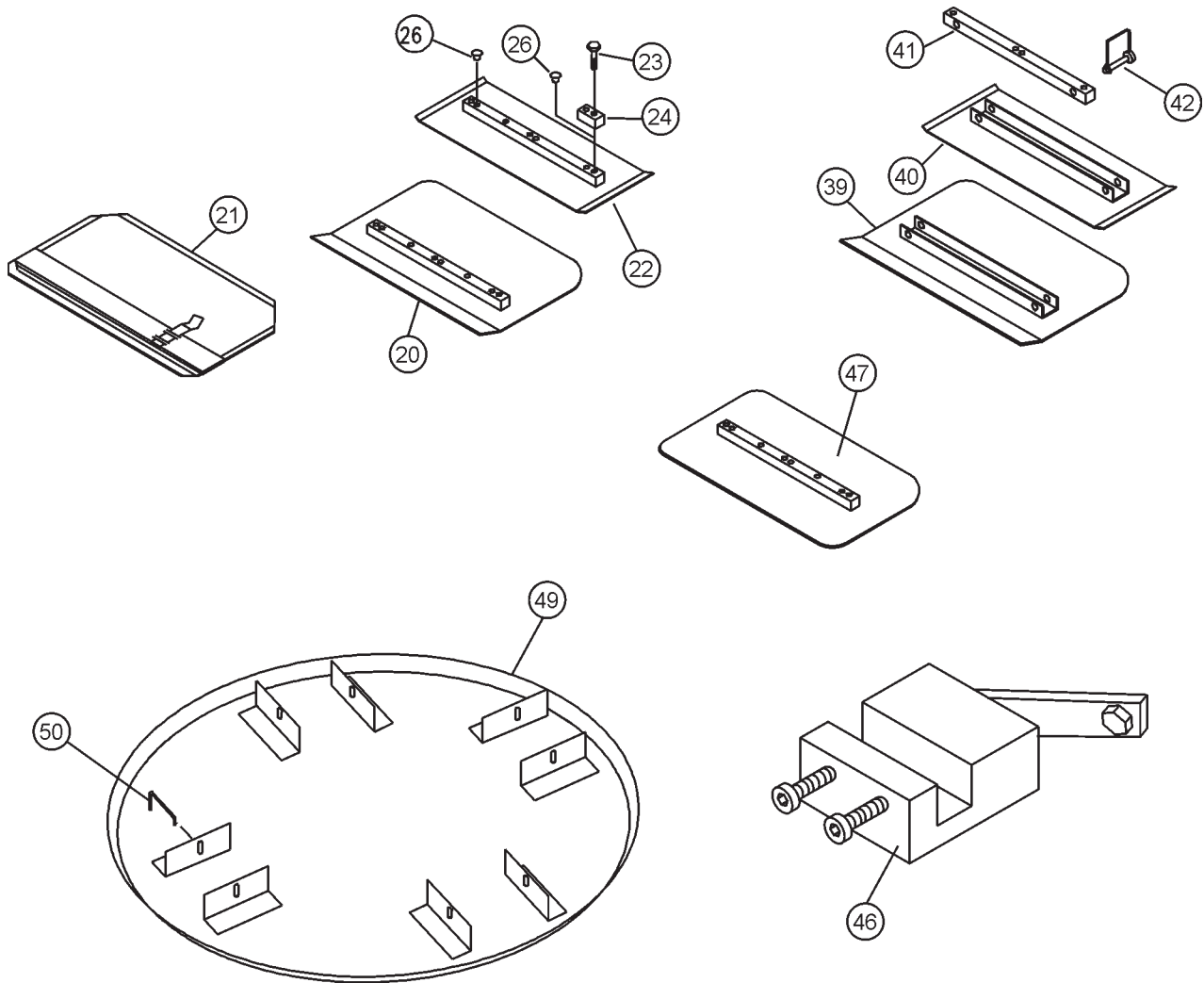

BLADES & ARM ADJ. FIXTURE ASSY. (OPTIONS)

<u>NO.</u>	<u>PART NO.</u>	<u>PART NAME</u>	<u>QTY.</u>	<u>REMARKS</u>
20		COMBO FLOAT & FINISH BLADE	4	CONTACT UNIT SALES DEPT./ACC. ITEM
20		ENDURO COMBO FLOAT & FINISH BLADE .	4	CONTACT UNIT SALES DEPT./ACC. ITEM
21		FLOAT BLADE	4	CONTACT UNIT SALES DEPT./ACC. ITEM
22		FINISH BLADE	4	CONTACT UNIT SALES DEPT./ACC. ITEM
22		ENDURO FINISH BLADE W/ROTATING	4	CONTACT UNIT SALES DEPT./ACC. ITEM
23	0202	HHCS 5/16-18X1" RING	4	
24	0201	GUARD RING LUG RING	4	
26	1434	TROWEL LUG (FINISH BLADE ONLY)	4	
27	1162 A	LUBRA-CAP	4	
28	7281	STABILIZER RING 14 1/2" ARM	1	
29	6014 C	HEX NUT 5/16-24	8	
30	1237	HHCS 5/16-18X7/8" NY-LOC	4	
39		UNIVERSAL COMBO BLADE	4	CONTACT UNIT SALES DEPT./ACC. ITEM
39		ENDURO UNIVERSAL COMBO BLADE	4	CONTACT UNIT SALES DEPT./ACC. ITEM
40		UNIVERSAL FINISH BLADE	4	CONTACT UNIT SALES DEPT./ACC. ITEM
40		ENDURO UNIVERSAL FINISH BLADE	4	CONTACT UNIT SALES DEPT./ACC. ITEM
41		UNIVERSAL MOUNTING BAR	4	CONTACT UNIT SALES DEPT./ACC. ITEM
42		SNAP PIN 1/4"X1.3/4"	8	CONTACT UNIT SALES DEPT./ACC. ITEM
44	0166 A	LOCK WASHER 3/8"	4	
46		TROWEL ARM ADJ. FIXTURE ASSY.	1	CONTACT UNIT SALES DEPT./ACC. ITEM
47		REVERSIBLE COMBO BLADE	4	CONTACT UNIT SALES DEPT./ACC. ITEM
48	1723	MALE R.H. ROD END 5/16"	1	
49		FLOAT DISC	1	CONTACT UNIT SALES DEPT./ACC. ITEM
50		FLOAT DISC LATCH PIN	4	CONTACT UNIT SALES DEPT./ACC. ITEM

LIFTING BAIL ASSY. (OPTION)

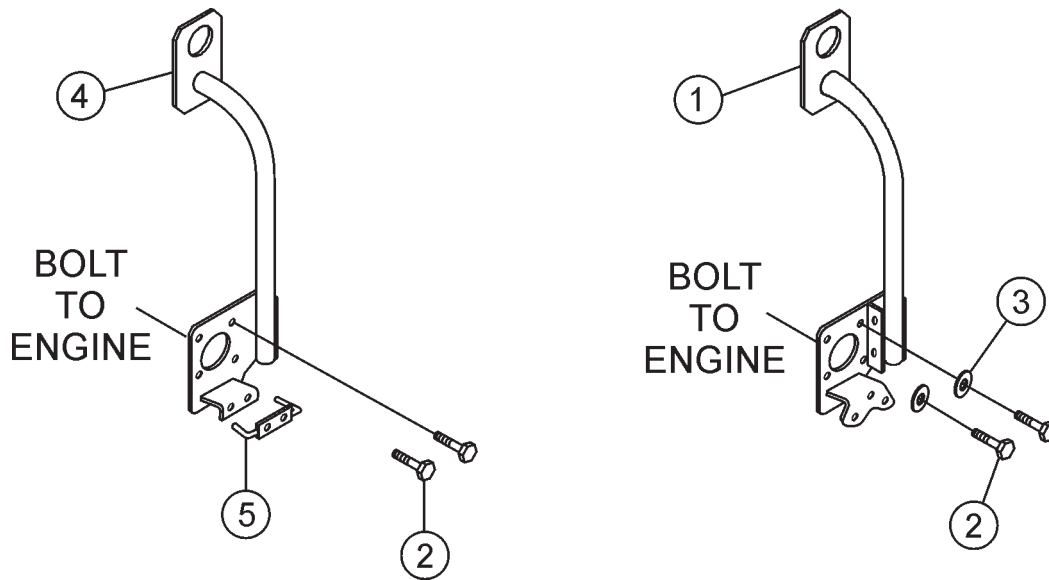

LIFTING BAIL ASSY. (OPTION)

<u>NO.</u>	<u>PART NO.</u>	<u>PART NAME</u>	<u>QTY.</u>	<u>REMARKS</u>
1		LIFTING BAIL ASSY. (13 HP MODEL) . 1	1	CONTACT UNIT SALES DEPT./ACC. ITEM
2	10229	HHCS 5/16-24X1"	4	
3	0161 A	LOCK WASHER 5/16"	4	
4		LIFTING BAIL ASSY. (11 HP MODEL) . 1	1	CONTACT UNIT SALES DEPT./ACC. ITEM
5	2360	RUNNER, BELT (11 HP MODEL)	1	

HONDA GX340K1QA2 — AIR CLEANER ASSY.

<u>NO.</u>	<u>PART NO.</u>	<u>PART NAME</u>	<u>QTY.</u>	<u>REMARKS</u>
1	16271ZE2000	GASKET, ELBOW	1	
2	17210ZE3505	ELEMENT, AIR CLEANER	1	
3	17218ZE3505	FILTER, OUTER	1	
4	17231ZE3W00	COVER, AIR CLEANER	1	
5	17232891000	GROMMET, AIR CLEANER	1	
6	17235ZH9N00	NOSE, MUFFLER	1	
7 *	17238ZE2310	COLLAR, AIR CLEANER	2	
8 *	17239ZE1000	COLLAR B, AIR CLEANER	1	
9	17410ZH9N00	ELBOW, AIR CLEANER	1	INCLUDES ITEMS W/*
11	90203ZA0800	WINGNUT, 6MM	1	
12	90325044000	WINGNUT, TOOL BOX SETTING	1	
13	934040602008	BOLT- WASHER, 6X20	1	
14	9405006000	NUT, FLANGE (6MM)	2	

HONDA GX340K1QA2 — CAMSHAFT ASSY.

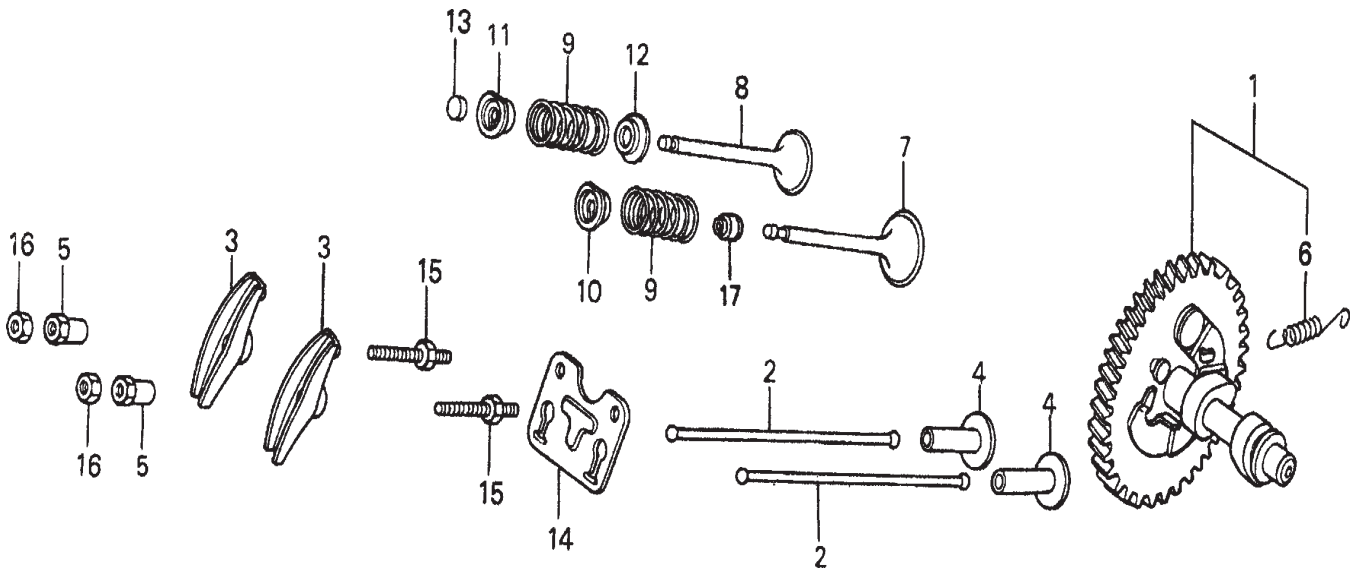

HONDA GX340K1QA2 — CAMSHAFT ASSY.

<u>NO.</u>	<u>PART NO.</u>	<u>PART NAME</u>	<u>QTY.</u>	<u>REMARKS</u>
1	14100ZE3305	CAMSHAFT ASSEMBLY	1	INCLUDES ITEMS W/*
2	14410ZE3013	ROD, PUSH	2	
3	14431ZE2010	ARM, VALVE ROCKER	2	
4	14441ZE2000	LIFTER, VALVE	2	
5	14451ZE1013	PIVOT, ROCKER ARM	2	
6*	14568ZE1000	SPRING, WEIGHT RETURN	1	
7	14711ZE3000	VALVE, IN.	1	
8	14721ZE3000	VALVE, EX.	1	
9	14751ZE2003	SPRING, VALVE	2	
10	14771ZE2000	RETAINER, IN. VALVE SPRING	1	
11	14773ZE2000	RETAINER, EX. VALVE SPRING	1	
12	14775ZE2010	SEAT, VALVE SPRING	1	
13	14781ZE2000	ROTATOR, VALVE	1	
14	14791ZE2010	PLATE, PUSH ROD GUIDE	1	
15	90012ZE0010	BOLT, PIVOT (8MM)	2	
16	90206ZE1000	NUT, PIVOT ADJ.	2	
17	12209ZE8003	SEAL, VALVE STEM	1	USE FROM ENGINE

HONDA GX340K1QA2 — PISTON ASSY.

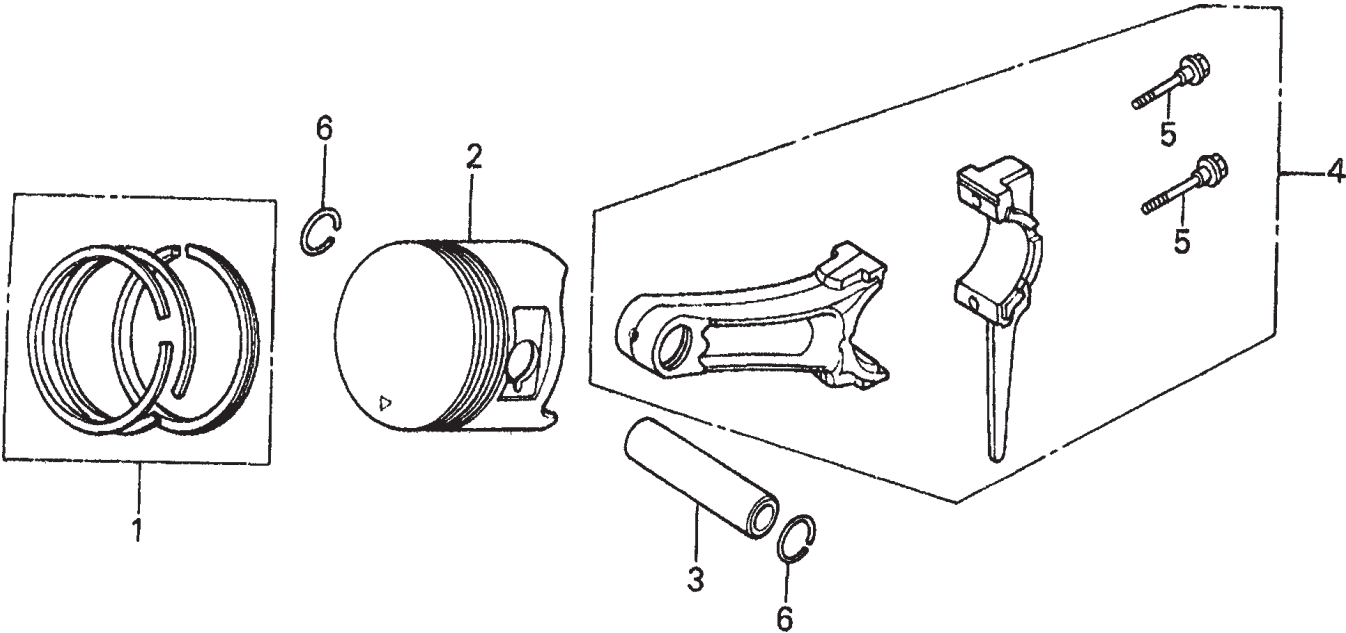

HONDA GX340K1QA2 — PISTON ASSY.

<u>NO.</u>	<u>PART NO.</u>	<u>PART NAME</u>	<u>QTY.</u>	<u>REMARKS</u>
1	13010ZE3003	RING SET, PISTON- STANDARD	1	
1	13011ZE3003	RING SET, PISTON- OS 0.25	1	
1	13012ZE3003	RING SET, PISTON- OS 0.50	1	
1	13013ZE3003	RING SET, PPISTON- 0.75	1	
2	13101ZE3W00	PISTON- STANDARD	1	
2	13102ZE3W00	PISTON- OS 0.25	1	
2	13103ZE3W00	PISTON- OS 0.50	1	
2	13104ZE3W00	PISTON- 0.75	1	
3	13111ZF6000	PIN, PISTON	1	
4	13200ZE3010	ROD ASSEMBLY, CONNECTING (STD.)	1	INCLUDES ITEMS W/*
4	13200ZE3315	ROD ASSEMBLY, CONNECTING- US 0.25	1	INCLUDES ITEMS W/*
5*	90001ZE8000	BOLT, CONNECTING ROD	2	
6	90601ZE3000	CLIP, PISTON PIN 20MM	2	

HONDA GX340K1QA2 — CRANKCASE COVER ASSY.

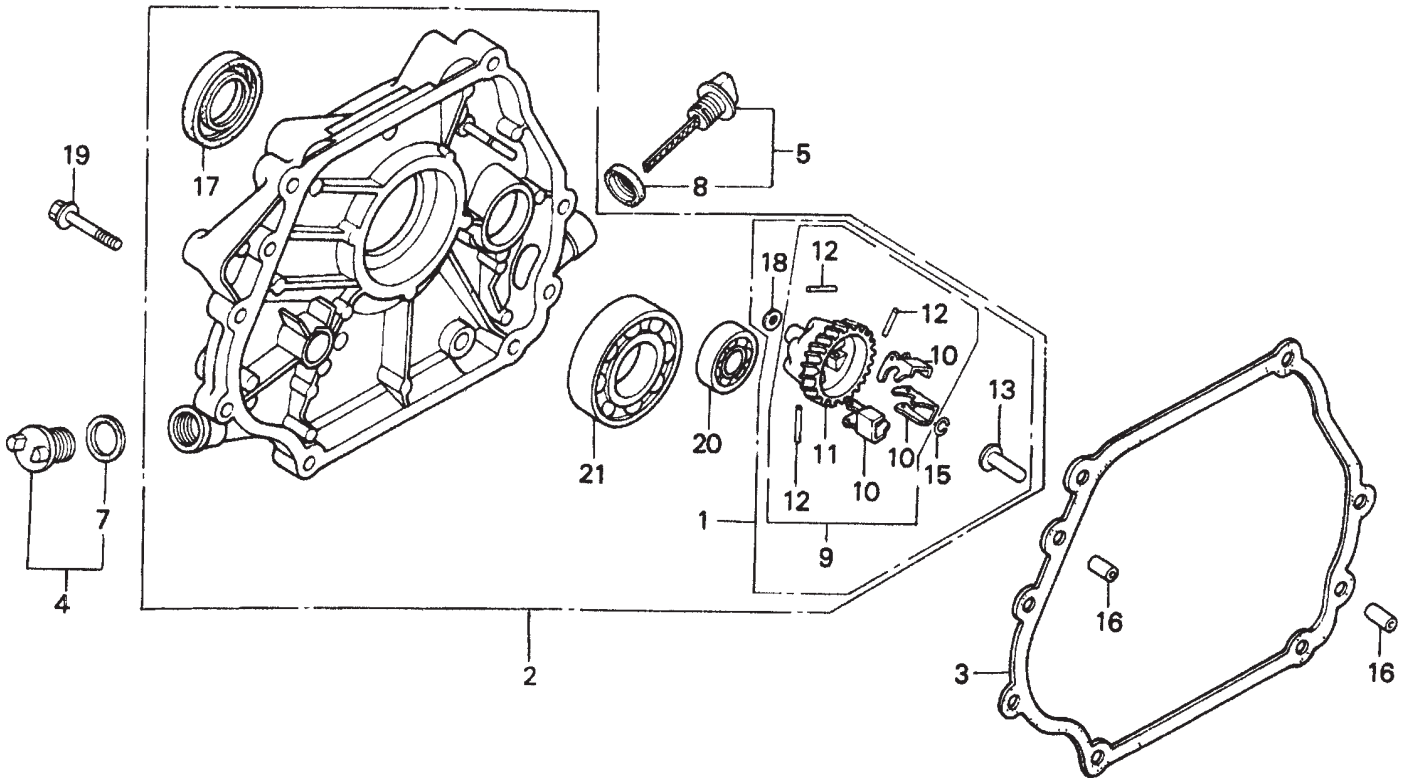

HONDA GX340K1QA2 — CRANKCASE COVER ASSY.

<u>NO.</u>	<u>PART NO.</u>	<u>PART NAME</u>	<u>QTY.</u>	<u>REMARKS</u>
1+	06165ZE3000	GOVERNOR KIT,	1	INCLUDES ITEMS W/*
2	11300ZE3602	COVER ASSEMBLY, CRANKCASE Q- TYPE ...	1	INCLUDES ITEMS W/+
3	11381ZE3801	GASKET, CASE COVER	1	
4	15600ZG4003	CAP ASSEMBLY, OIL FILLER	1	INCLUDES ITEMS W/\$
5	15600735003	CAP ASSEMBLY, OIL FILLER	1	INCLUDES ITEMS W/■
7\$	15625ZE1003	GASKET, OIL FILLER CAP	1	
8■	15625ZE1003	GASKET, OIL FILLER CAP	1	
9+	16510ZE3000	GOVERNOR ASSEMBLY	1	INCLUDES ITEMS W/%
10*+%	16511ZE8000	WEIGHT, GOVERNOR	3	
11*+%	16512ZE3000	HOLDER, GOVERNOR WEIGHT	1	
12*+%	16513ZE2000	PIN, GOVERNOR WEIGHT	3	
13*+	16531ZE2000	SLIDER, GOVERNOR	1	
15*+	90602ZE1000	CLIP, GOVERNOR HOLDER	1	
16	90701HC4000	PIN, DOWEL 8X12	2	
17+	91201ZE3004	OIL SEAL 35X52X8	1	
18*+	9410106800	WASHER, PLAIN 6MM	1	
19	957010804000	BOLT, FLANGE 8X40	7	
20+	961006202000	BEARING, RADIAL BALL 6202	1	
21+	961006207000	BEARING, RADIAL BALL 6207	1	

HONDA GX340K1QA2 — CRANKSHAFT ASSY.

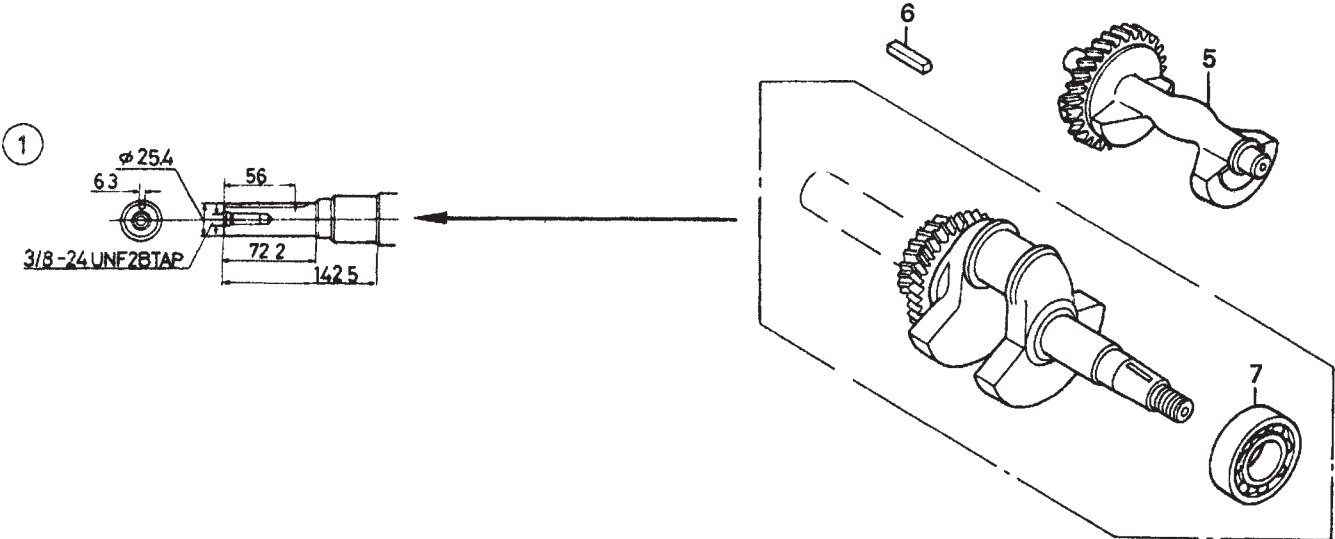

HONDA GX340K1QA2 — CRANKSHAFT ASSY.

<u>NO.</u>	<u>PART NO.</u>	<u>PART NAME</u>	<u>QTY.</u>	<u>REMARKS</u>
1	13310ZE3601	CRANKSHAFT Q- TYPE	1	INCLUDES ITEMS W/*
5	13351ZE3010	WEIGHT, BALANCER	1	
6	90756ZE2600	KEY 6.3X6.3X43	1	
7	961006207000	BEARING, RADIAL BALL 6207	1	

HONDA GX340K1QA2 — CYLINDER BARREL ASSY.

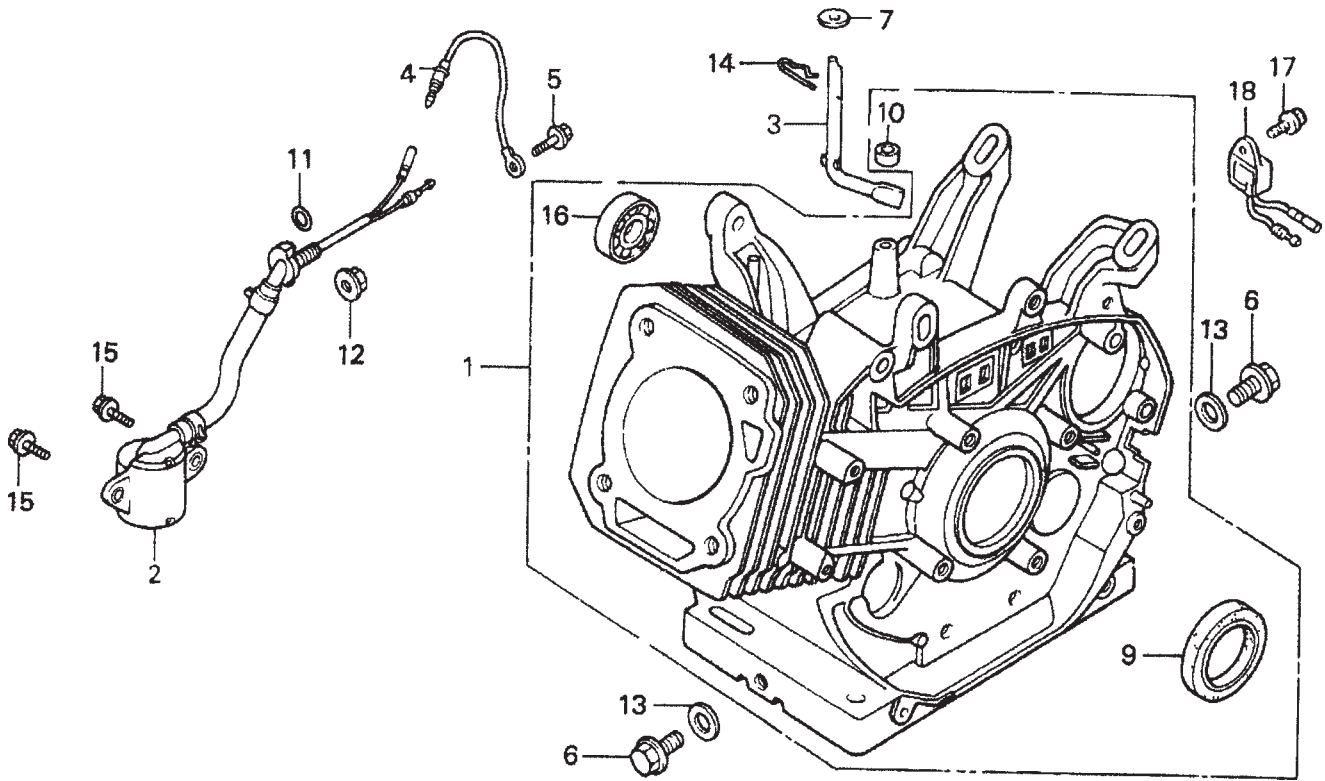

HONDA GX340K1QA2 — CYLINDER BARREL ASSY.

<u>NO.</u>	<u>PART NO.</u>	<u>PART NAME</u>	<u>QTY.</u>	<u>REMARKS</u>
1	12000ZE3816	CYLINDER ASSEMBLY	1	INCLUDES ITEMS W/*
2	15510ZE2043	SWITCH ASSEMBLY, OIL LEVEL	1	USE FROM ENGINE SN 2639738 TO 2786139
3	16541ZE3010	SHAFT, GOVERNOR ARM	1	
4	32197ZE2003	SUB- HARNESS	1	USE UP TO ENGINE SN 2639737
5	90013883000	BOLT,FLANGE 6X12 (CT200)	1	USE UP TO ENGINE SN 2639737
6	90131896650	BOLT, DRAIN PLUG	2	
7	90446KE1000	WASHER 8.2X17X0.8	1	
9*	91201ZE3004	OIL SEAL 35X52X8	1	
10*	91201ZE9003	OIL SEAL 8X14X5	1	
11	91353671003	O- RING 13.5X1.5	1	
12	9405010000	NUT, FLANGE 10MM	1	
13	9410912000	WASHER, DRAIN PLUG 12MM	2	
14	9425110000	PIN, LOCK 10MM	1	
15	957010601200	BOLT, FLANGE 6X12	2	
16*	961006202000	BEARING, RADIAL BALL 6202	1	
17	90013883000	BOLT, FLANGE 6X12 (CT200)	1	
18	34150ZH7003	ALERT UNIT, OIL	1	

HONDA GX340K1QA2 — CYLINDER HEAD ASSY.

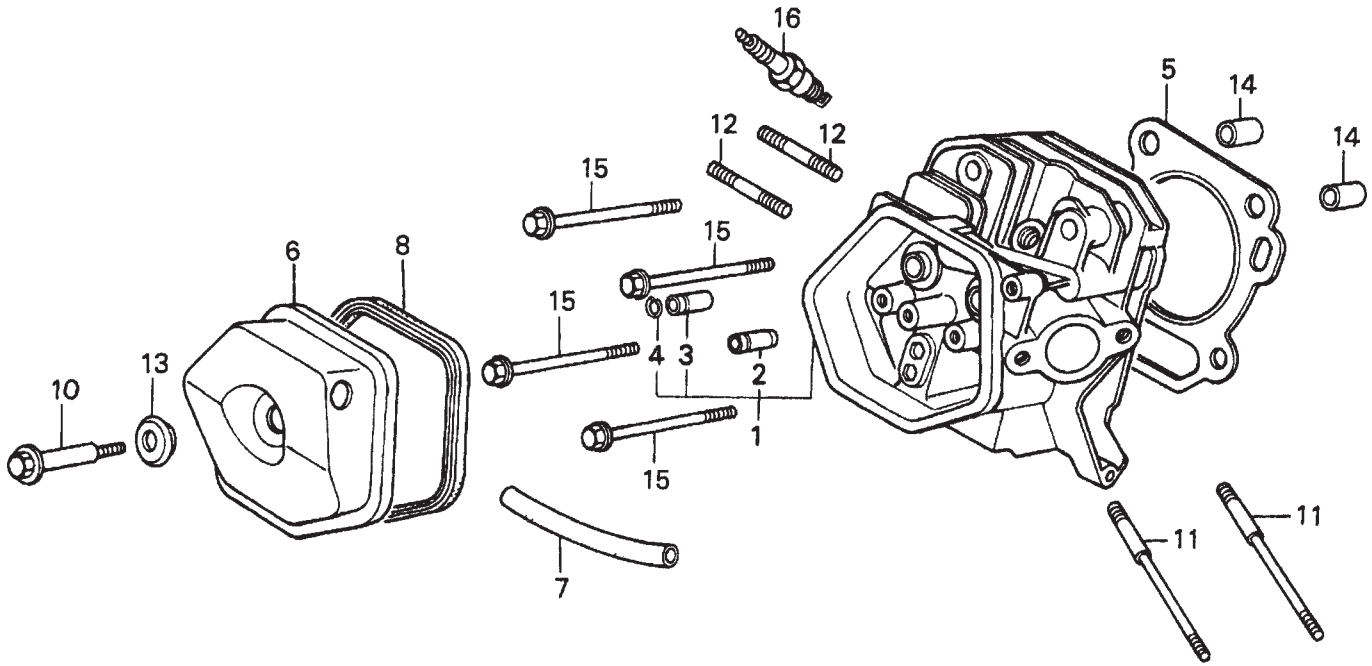

HONDA GX340K1QA2 — CYLINDER HEAD ASSY.

<u>NO.</u>	<u>PART NO.</u>	<u>PART NAME</u>	<u>QTY.</u>	<u>REMARKS</u>
1	12200ZF6W01	CYLINDER HEAD	1	INCLUDES ITEMS W/*
2*	12204ZE2306	GUIDE, EX. VALVE OS (OPTIONAL)	1	
3*	12205ZE2305	GUIDE, EX. VALVE OS (OPTIONAL)	1	
4*	12216ZE2300	CLIP, VALVE GUIDE	1	
5	12251ZE3W00	GASKET, CYLINDER HEAD	1	
6	12310ZE3791	COVER, HEAD	1	
7	12315ZE3840	TUBE, BREATHER	1	
8	12391ZE2020	GASKET, CYLINDER HEAD COVER	1	
10	90014ZE2000	BOLT, HEAD COVER	1	
11	90042ZE8000	BOLT, STUD 8X131.5	2	
12	90047ZE2000	BOLT, STUD 8X47	2	USE UP TO ENGINE SN 3033461
12	92900080320E	BOLT 2, STUD 8X32	2	USE FROM ENGINE SN 3033462
13	90441ZE2010	WASHER, HEAD COVER	1	
14	9430112200	PIN A, DOWEL 12X20	2	
15	957011008000	BOLT, FLANGE 10X80	4	
16	9807956846	SPARK PLUG, BPR6ES (NGK)	1	

HONDA GX340K1QA2 — FAN COVER ASSY.

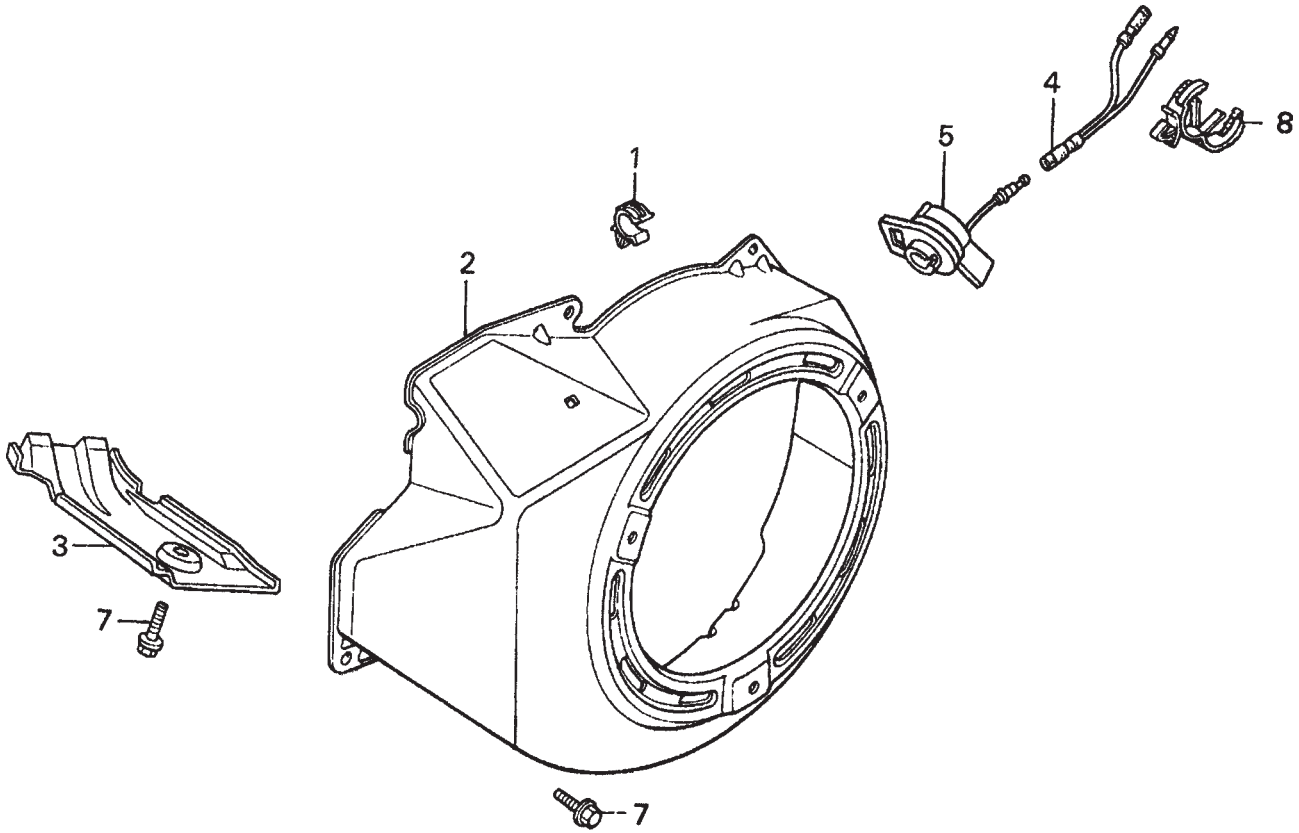

HONDA GX340K1QA2 — FAN COVER ASSY.

<u>NO.</u>	<u>PART NO.</u>	<u>PART NAME</u>	<u>QTY.</u>	<u>REMARKS</u>
1	16731ZE2003	CLIP, TUBE	1	
2	19610ZE3010ZA	COVER, FAN *R8* (BRIGHT RED)	1	
3	19631ZE3W00	SHROUD	1	
4	32197ZH8003	SUB- HARNESS	1 USE UP TO ENGINE SN 2639737
5	36100ZE1015	SWITCH ASSEMBLY, ENGINE STOP	1 USE UP TO ENGINE SN 2639737
5	36100ZH7003	SWITCH ASSEMBLY, ENGINE STOP	1 USE FROM ENGINE SN 2639738
7	90013883000	BOLT, FLANGE 6X12 (CT200)	6	
8	90684ZA0601	CLIP, WIRE HARNESS	1	

HONDA GX340K1QA2 — FLYWHEEL ASSY.

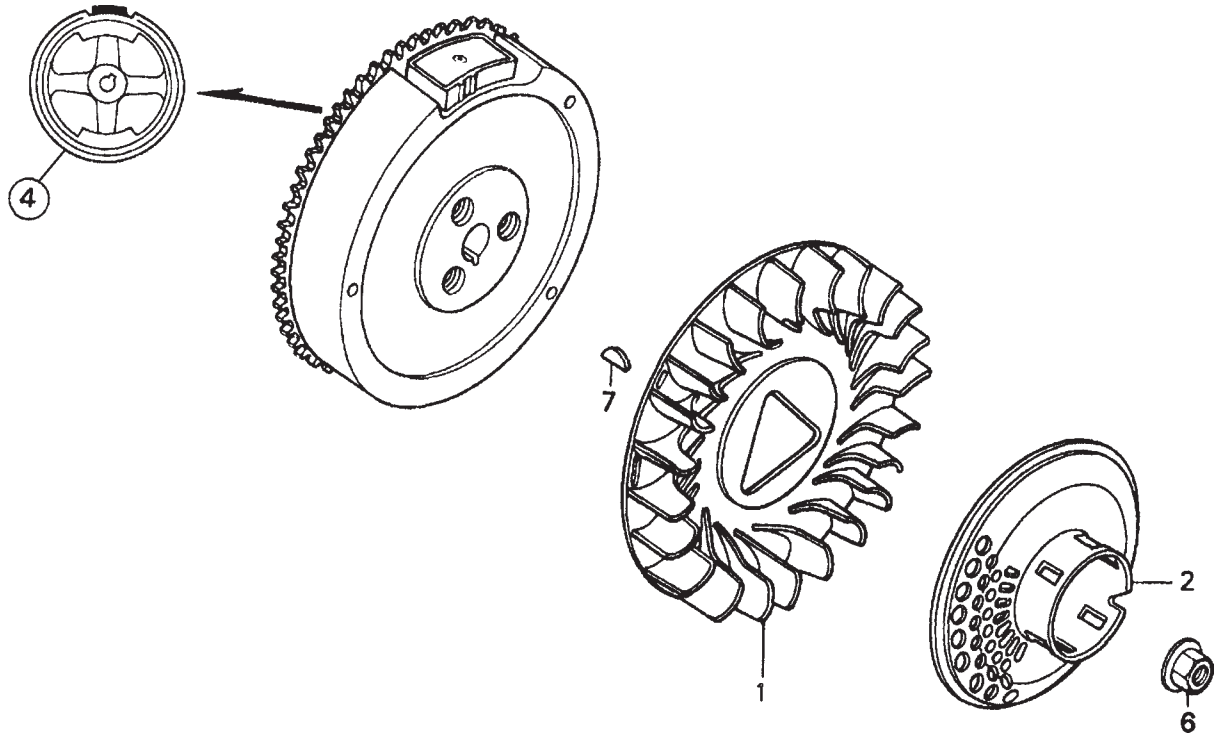

HONDA GX340K1QA2 — FLYWHEEL ASSY.

<u>NO.</u>	<u>PART NO.</u>	<u>PART NAME</u>	<u>QTY.</u>	<u>REMARKS</u>
1	19511ZE3000	FAN, COOLING	1	
2	28450ZE3W11	PULLEY, STARTER (SCREEN GRID)	1	
4	31100ZE3701	FLYWHEEL	1	
6	90201ZE3V00	NUT, SPECIAL 16MM (1)	1 USE FROM ENGINE SN 2536523
6	90201ZE3790	NUT, SPECIAL 16MM	1 USE UP TO ENGINE SN 2536522
7	90741ZE2000	KEY, SPECIAL WOODRUFF 25X18	1	

HONDA GX340K1QA2 — FUEL TANK ASSY.

<u>NO.</u>	<u>PART NO.</u>	<u>PART NAME</u>	<u>QTY.</u>	<u>REMARKS</u>
1	16854ZH8000	RUBBER, SUPPORTER 107MM	1	
2	16955ZE1000	JOINT, FUEL TANK	1	
3	17510ZE3010ZA	TANK, FUEL *NH31* (MCKINLEY WHITE)	1	
3	17510ZE3010ZD	TANK FUEL *T34* (SIMPSON BLUE)	1	
5	17620ZH7023	CAP, FUEL FILLER	1	INCLUDES ITEMS W/*
6*	17631ZH7003	GASKET, FUEL FILLER CAP	1	
7	17672ZE2W01	FILTER, FUEL	1	
10	91353671003	O- RING 13.5X1.5 (ARA)	1	
11	9405008000	NUT, FLANGE 8MM	2	
12	950014500360M	BULK HOSE, FUEL (4.5X3000) (4.5X235)	1	
13	9500202080	CLIP, TUBE B8	2	
14	957010802500	BOLT, FLANGE 8X25	2	

HONDA GX340K1QA2 — IGNITION COIL ASSY.

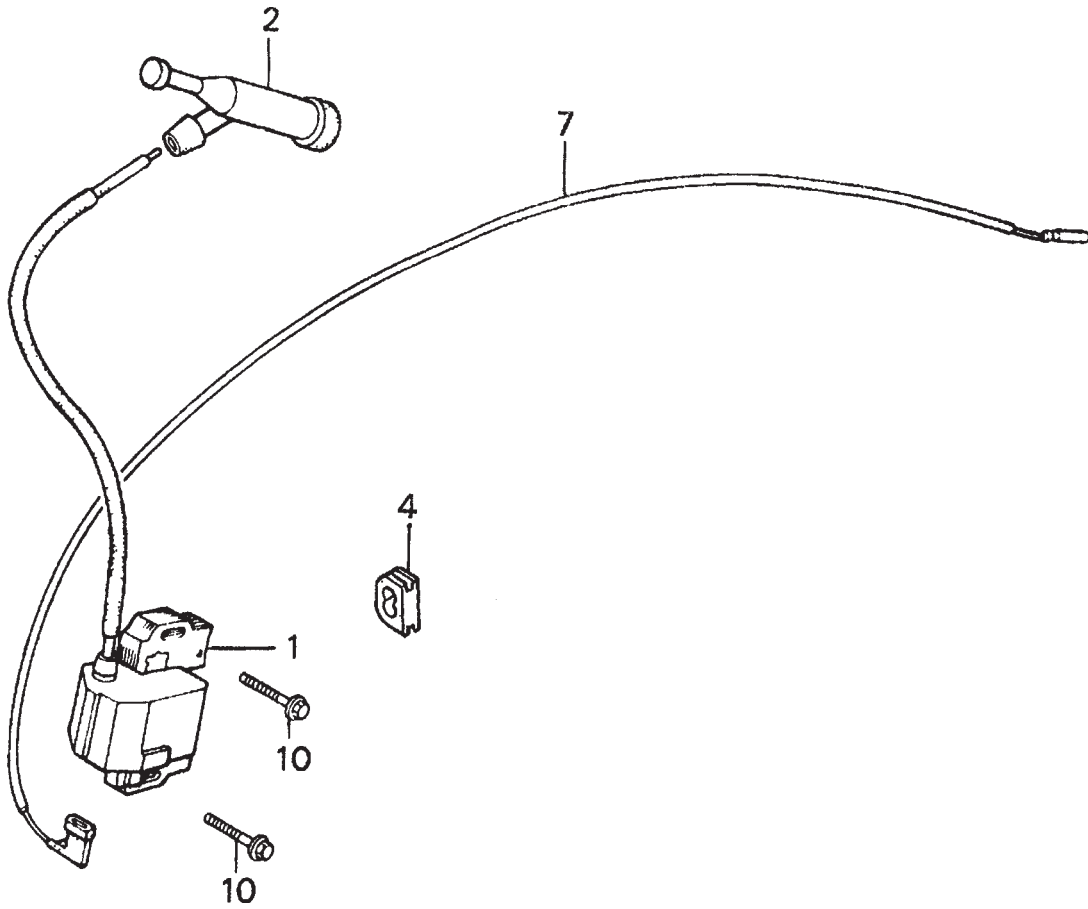

HONDA GX340K1QA2 — IGNITION COIL ASSY.

<u>NO.</u>	<u>PART NO.</u>	<u>PART NAME</u>	<u>QTY.</u>	<u>REMARKS</u>
1	30500ZE2023	COIL ASSEMBLY, IGNITION	1	
2	30700ZE1013	CAP ASSEMBLY, NOISE SUPPRESSOR	1	
4	31512ZE2000	GROMMET, WIRE	1	
7	36101ZE2701	WIRE, STOP SWITCH 430MM	1	
10	90015883000	BOLT, FLANGE 6X28	2	

HONDA GX340K1QA2 — CARBURETOR ASSY.

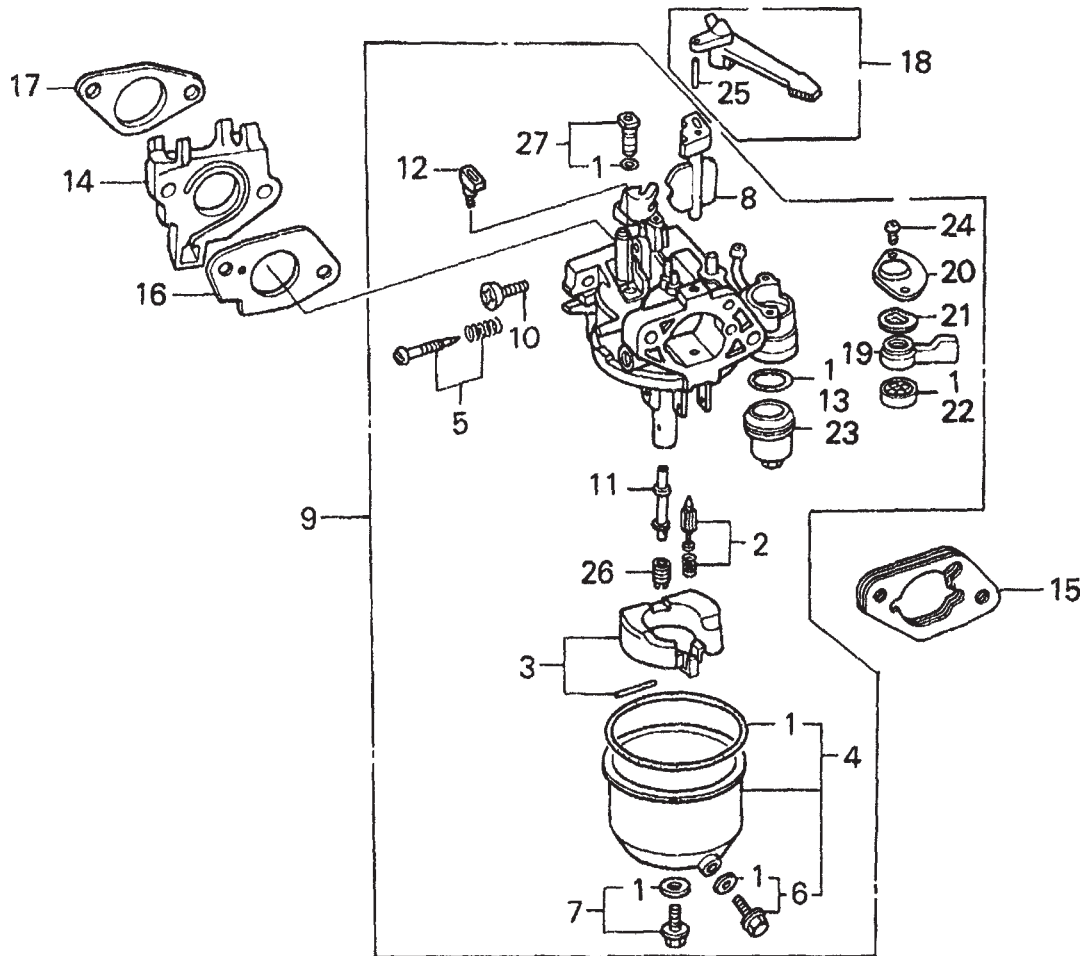

HONDA GX340K1QA2 — CARBURETOR ASSY.

<u>NO.</u>	<u>PART NO.</u>	<u>PART NAME</u>	<u>QTY.</u>	<u>REMARKS</u>
1*%	16010ZE2812	GASKET SET	1	
2*	16011ZA0931	VALVE SET, FLOAT	1	
3*	16013ZA0931	FLOAT SET	1	
4*	16015ZE2005	CHAMBER SET, FLOAT	1	INCLUDES ITEMS W/% USE UP TO ENGINE SN BE80B A
4*	16015ZE8005	CHAMBER SET, FLOAT	1	INCLUDES ITEMS W/% USE FROM ENGINE SN BE80B B
5*	16016ZH7W01	SCREW SET	1	
6*%	16024ZE1811	SCREW SET, DRAIN	1	
7*	16028ZE0005	SCREW SET B	1	
8*	16044ZE3811	CHOKE SET	1	
9	16100ZE3V00	CARBURETOR ASSEMBLY, BE85B A	1	INCLUDES ITEMS W/* USE UP TO ENGINE SN 2519695
9	16100ZE3V01	CARBURETOR ASSEMBLY, BE80B B	1	USEFROM ENGINE SN 2519696
9	16100ZE3V01	CARBURETOR ASSEMBLY, BE80B B	1	USE UP TO ENGINE SN 2519695
10*	16124ZE0005	SCREW, THROTTLE STOP	1	
11*	16166ZE3W50	NOZZLE, MAIN	1	
12*	16172ZE3W10	COLLAR, SET	1	
13	16173001004	GASKET, FUEL STRAINER CUP	1	
14	16211ZE3000	INSULATOR, CARBURETOR	1	
15	16220ZA0702	SPACER, CARBURETOR	1	
16	16221ZE3800	GASKET, CARBURETOR	1	
17	16223ZE3800	GASKET, INSULATOR	1	
18	16610ZE1000	LEVER, CHOKE (STANDARD)	1	INCLUDES ITEMS W/+
19	16953ZE1812	LEVER, VALVE	1	USE FROM ENGINE SN BE80B B
20	16954ZE1812	PLATE, LEVER SETTING	1	USE FROM ENGINE SN BE80B B
21*	16956ZE1811	SPRING, VALVE LEVER	1	
22*	16957ZE1812	GASKET, VALVE	1	
23*	16967ZE0811	CUP, FUEL STRAINER	1	
24*	93500030060H	SCREW, PAN (3X6)	2	USE FROM ENGINE SN BE80B B
25+	9430520122	PIN, SPRING (2X12)	1	
26	99101ZH80880	JET, MAIN #88 (OPTIONAL)	1	
26	99101ZH80900	JET, MAIN #90 (OPTIONAL)	1	
26	99101ZH80920	JET, MAIN #92 (OPTIONAL)	1	
27	99204ZE00350	JET SET, PILOT #35	1	

HONDA GX340K1QA2 — CARBURETOR ASSY.

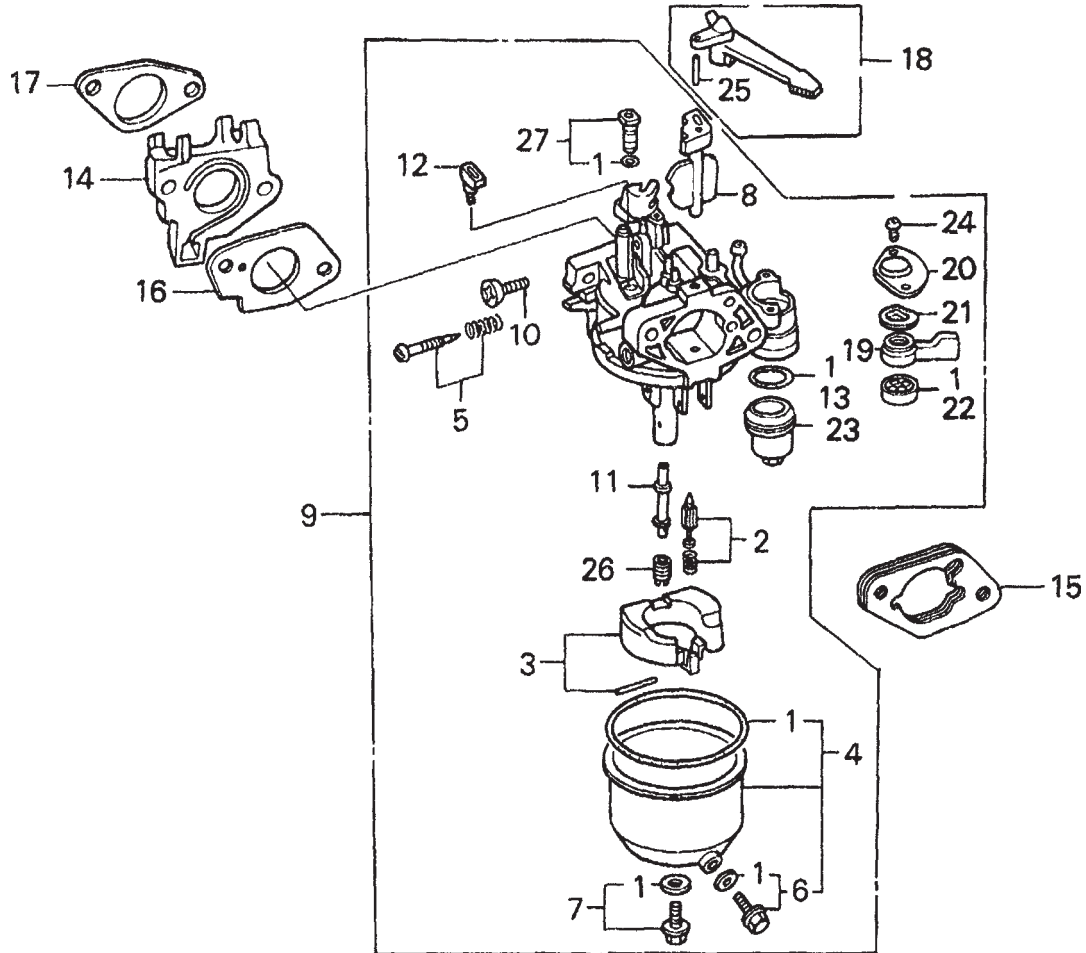

HONDA GX340K1QA2 — CARBURETOR ASSY.

<u>NO.</u>	<u>PART NO.</u>	<u>PART NAME</u>	<u>QTY.</u>	<u>REMARKS</u>
21*	16956ZE1811	SPRING, VALVE LEVER	1	
22*	16957ZE1812	GASKET, VALVE	1	
23*	16967ZE0811	CUP, FUEL STRAINER	1	
24*	93500030060H	SCREW, PAN (3X6)	2 USE FROM ENGINE SN BE80B B
25+	9430520122	PIN, SPRING (2X12)	1	
26	99101ZH80880	JET, MAIN #88 (OPTIONAL)	1	
26	99101ZH80900	JET, MAIN #90 (OPTIONAL)	1	
26	99101ZH80920	JET, MAIN #92 (OPTIONAL)	1	
27	99204ZE00350	JET SET, PILOT #35	1	

HONDA GX340K1QA2 — MUFFLER ASSY.

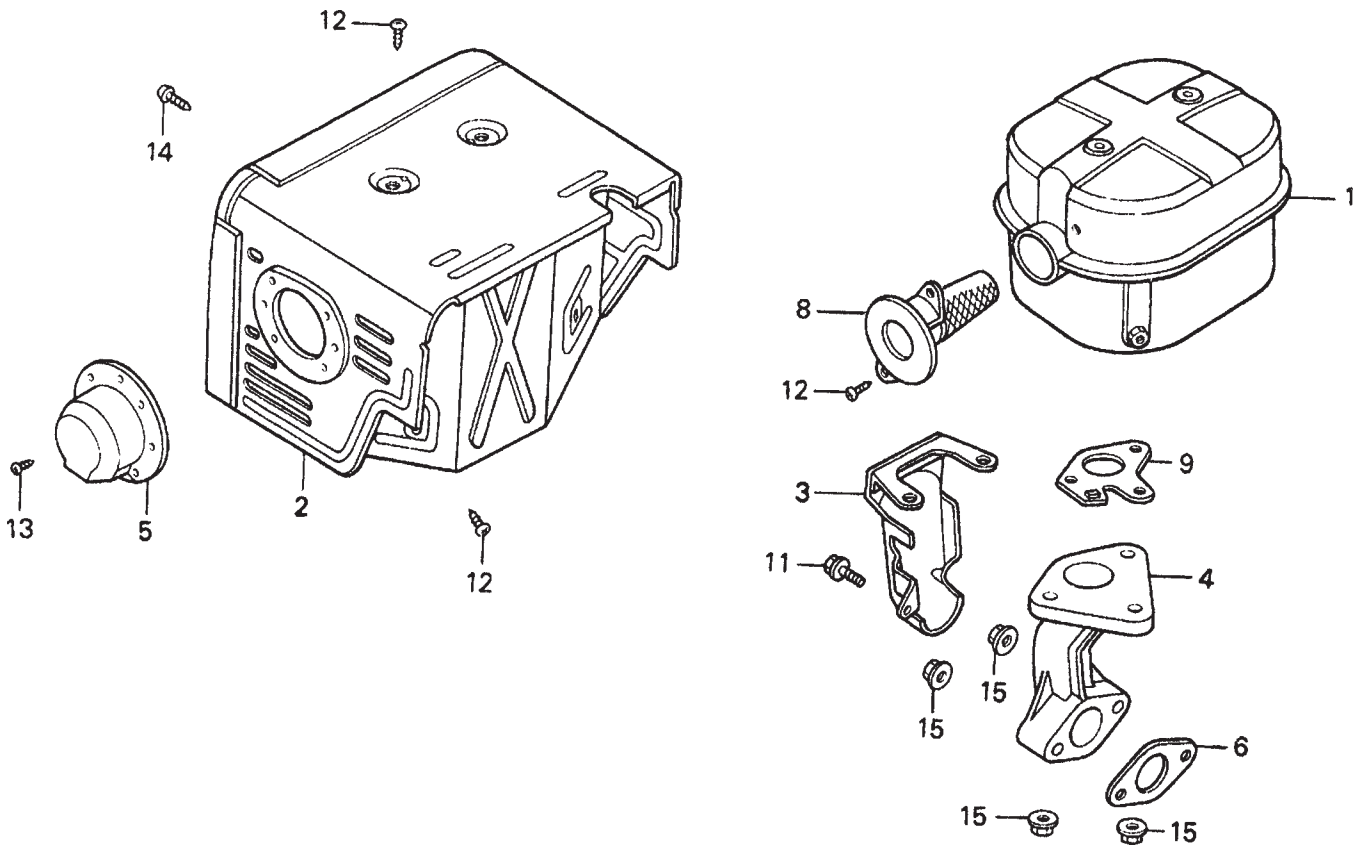

HONDA GX340K1QA2 — MUFFLER ASSY.

<u>NO.</u>	<u>PART NO.</u>	<u>PART NAME</u>	<u>QTY.</u>	<u>REMARKS</u>
1	18310ZE3W00	MUFFLER	1	
2	18320ZE3W01	PROTECTOR, MUFFLER	1	
3	18323ZE3W40	PROTECTOR, EX. PIPE	1	
4	18330ZE2W00	PIPE, EX.	1	
5	18331ZE3810	CAP, MUFFLER	1	
6	18333ZF6W01	GASKET, EX. PIPE	1	
6	18333ZK6Y00	GASKET, EX. PIPE (WACKER)	1	
8	18355ZE3010	ARRESTER, SPARK	1	
9	18381ZE2W10	GASKET, MUFFLER (ARRESTER)	1	
11	90013883000	BOLT, FLANGE 6X12 (CT200)	1	
12	90050ZE1000	SCREW, TAPPING 5X8	6	
13	90055ZE1000	SCREW, TAPPING 4X6	3	
14	93500060060B	SCREW, PAN 6X6	1	
15	9405008000	NUT, FLANGE 8MM	5	

HONDA GX340K1QA2 — RECOIL STARTER ASSY.

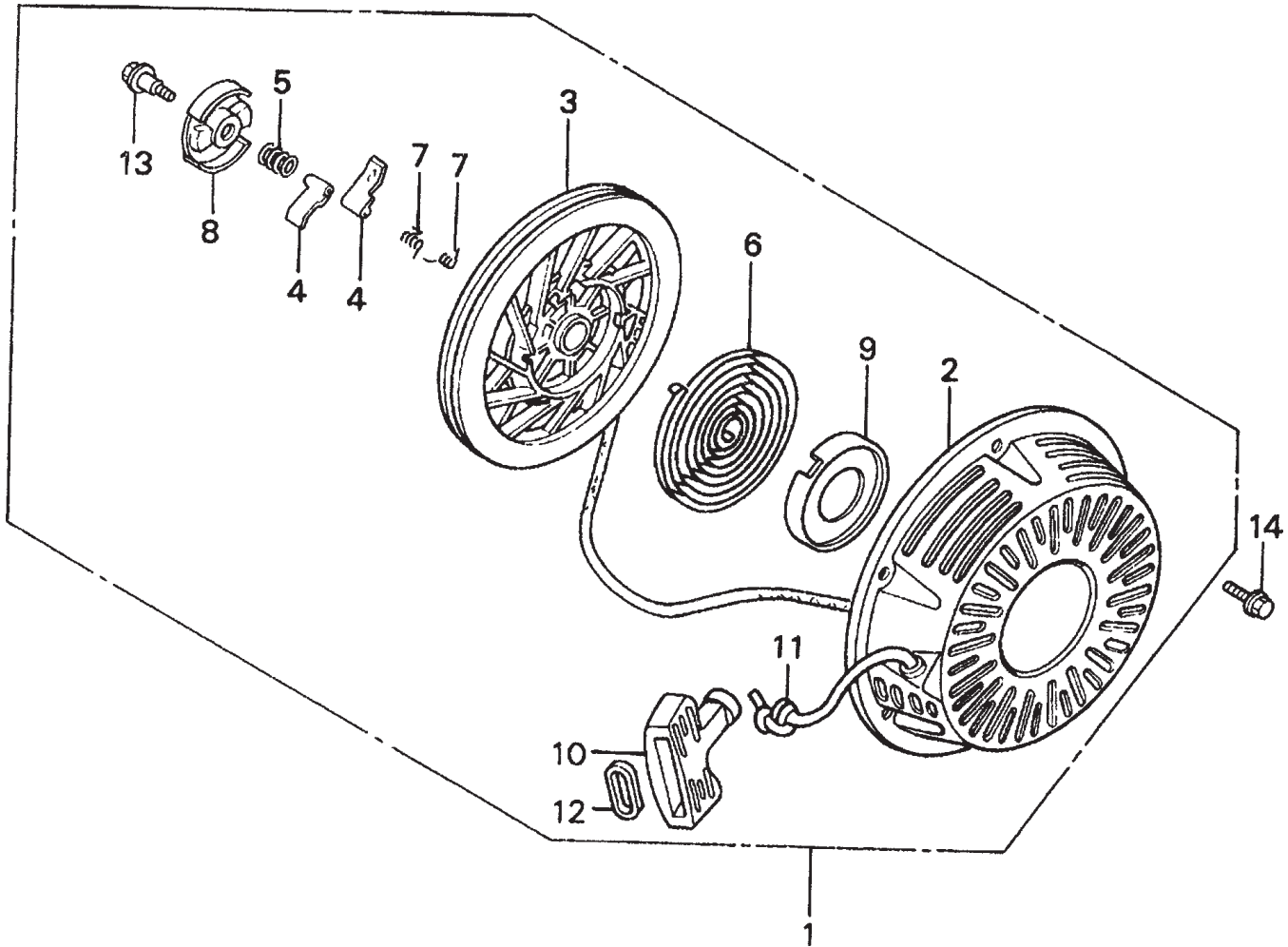

HONDA GX340K1QA2 — RECOIL STARTER ASSY.

<u>NO.</u>	<u>PART NO.</u>	<u>PART NAME</u>	<u>QTY.</u>	<u>REMARKS</u>
1	28400ZEW01ZA	STARTER ASSY., RECOIL *R8* BGHT RED	1	INCLUDES ITEMS W/*
2*	28410ZE3W01ZA	CASE, RECOIL STARTER *R8* BGHT RED	1	
3*	28421ZE3W01	PULLEY, RECOIL STARTER	1	
4*	28422ZE2W01	RATCHET, STARTER	2	
5*	28441ZE2W01	SPRING, FRICTION	1	
6*	28442ZE2W01	SPRING, STARTER RETURN	1	
7*	28443ZE2W01	SPRING, RATCHET	2	
8*	28444ZE2W01	RETAINER, SPRING	1	
9*	28445ZE2W01	HOLDER, SPRING	1	
10*	28461ZE2W02	GRIP, STARTER	1	
11*	28462ZE3W01	ROPE, RECOIL STARTER	1	
12*	28469ZE2W01	GRIP, REINFORCEMENT	1	USE UP TO ENG. SN 2935312
13*	90004ZE2W01	SCREW, CENTER	1	
14	957010600800	BOLT, FLANGE 6X8	3	

NO ART WORK

HONDA GX340K1QA2 — CONTROL ASSY.

<u>NO.</u>	<u>PART NO.</u>	<u>PART NAME</u>	<u>QTY.</u>	<u>REMARKS</u>
2	16551ZE3000	ARM, GOVERNOR	1	
3	16555ZE3000	ROD, GOVERNOR	1	
4	16561ZE3000	SPRING, GOVERNOR	1	
5	16562ZE3000	SPRING, THROTTLE RETURN	1	
7	16570ZE3W20	CONTROL ASSEMBLY, REMOTE	1	
8	16571ZE3W00	LEVER, CONTROL	1	
9	16574ZE1000	SPRING, LEVER	1	
10	16575ZE2W00	WASHER, CONTROL LEVER	1	
11	16576891000	HOLDER, CABLE	1	
12	16589ZE1000	SPACER, CONTROL LEVER	1	
14	16584883300	SPRING, CONTROL ADJUSTING	1	
15	16592883310	SPRING, CABLE RETURN	1	
17	90013883000	BOLT, FLANGE 6X12 (CT200)	2	
18	90015ZE5010	BOLT, GOVERNOR ARM	1	
19	90114SA0000	NUT, SELF- LOCK 6MM	1	
22	93500050320A	SCREW, PAN 5X32	1	
23	93500050160A	SCREW, PAN 5X16	1	
24	9405006000	NUT, FLANGE 6MM	1	

HONDA GX340K1QA2 — LABELS ASSY.

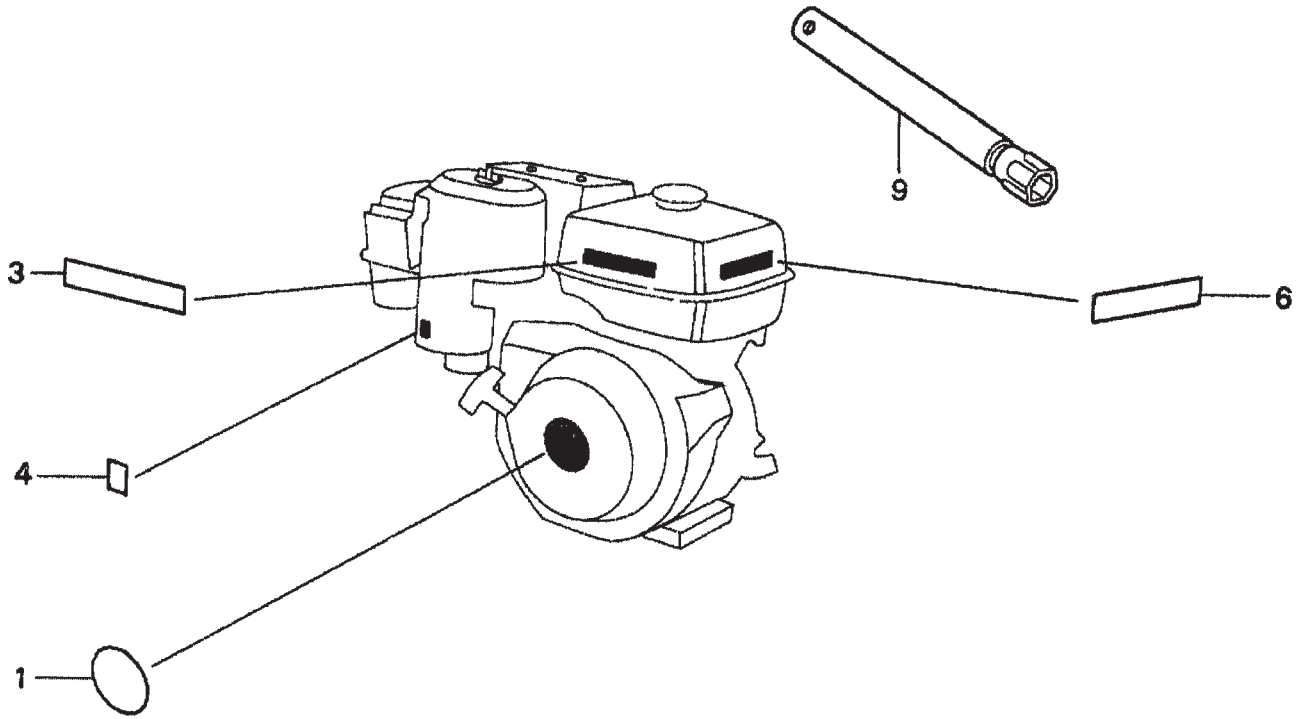

HONDA GX340K1QA2 — LABELS ASSY.

<u>NO.</u>	<u>PART NO.</u>	<u>PART NAME</u>	<u>QTY.</u>	<u>REMARKS</u>
1	87521ZE3W01	EMBLEM	1	
3	87522ZH9000	LABEL, CAUTION	1	
4	87528ZE2810	MARK, CHOKE (EXTERNAL)	1	
6	87532ZH8810	MARK, OIL ALERT (E)	1	
9	89218ZE1000	WRENCH, SPARK PLUG	1	

HONDA GX390K1QA2— AIR CLEANER ASSY.

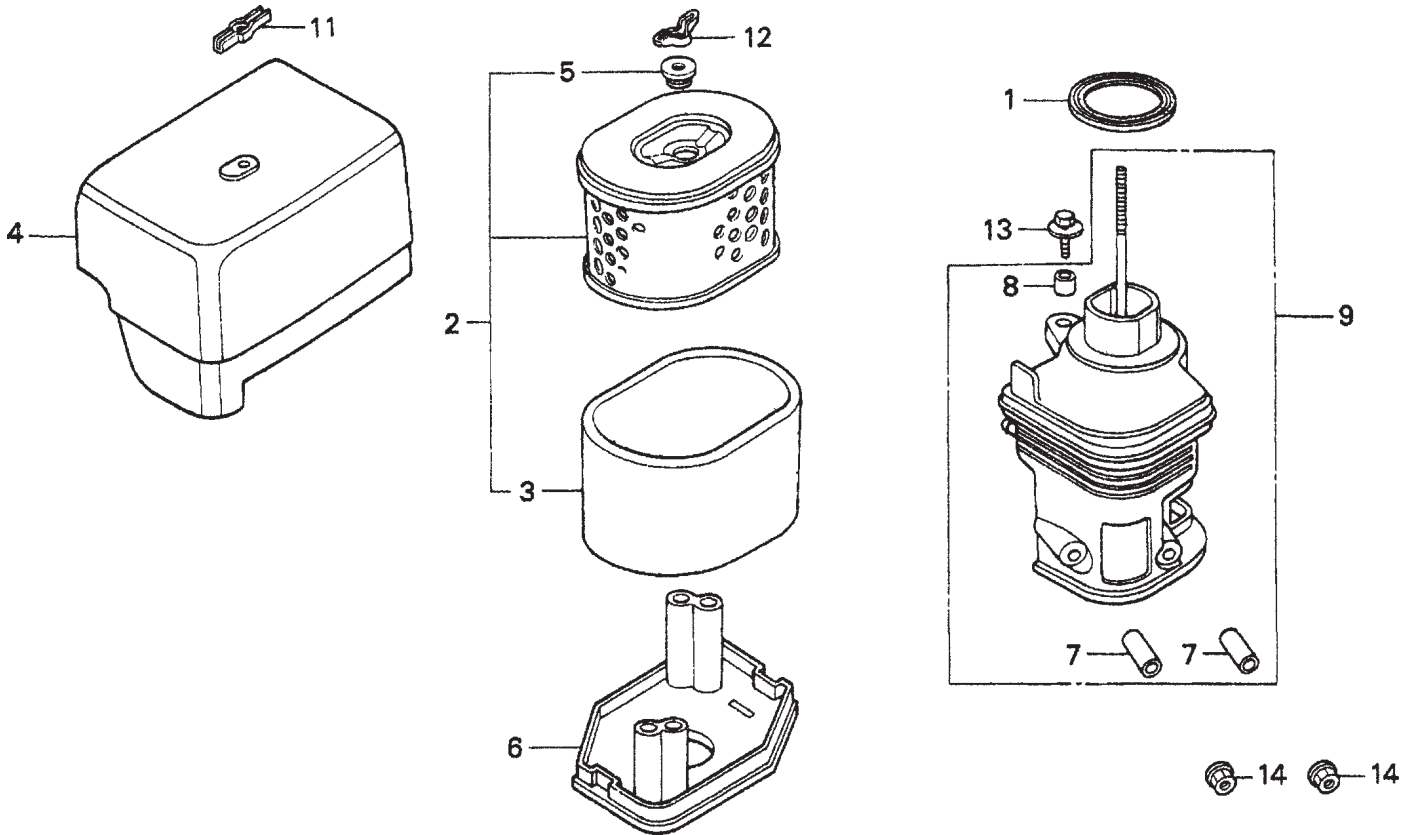

HONDA GX390K1QA2— AIR CLEANER ASSY.

<u>NO.</u>	<u>PART NO.</u>	<u>PART NAME</u>	<u>QTY.</u>	<u>REMARKS</u>
1	16271ZE2000	GASKET, ELBOW	1	
2	17210ZE3505	ELEMENT, AIR CLEANER	1	INCLUDES ITEMS W/#
3#	17218ZE3505	FILTER, OUTER	1	
4	17231ZE3W00	COVER, AIR CLEANER	1	USE UP TO ENGINE SN3125749
4	17231ZE3W01	COVER, AIR CLEANER	1	
5#	17232891000	GROMMET, AIR CLEANER	1	
7*	17238ZE2310	COLLAR, AIR CLEANER	2	
8*	17239ZE1000	COLLAR B, AIR CLEANER	1	
9	17410ZH9N00	ELBOW, AIR CLEANER	1	INCLUDES ITEMS W/*
11	90203ZA0800	WINGNUT, 6MM	1	
12	90325044000	WINGNUT, TOOL BOX SETTING	1	
13	90009ZE2003	BOLT- WASHER 6X22	1	
14	9405006000	NUT, FLANGE 6MM	2	

HONDA GX390K1QA2— CAMSHAFT ASSY.

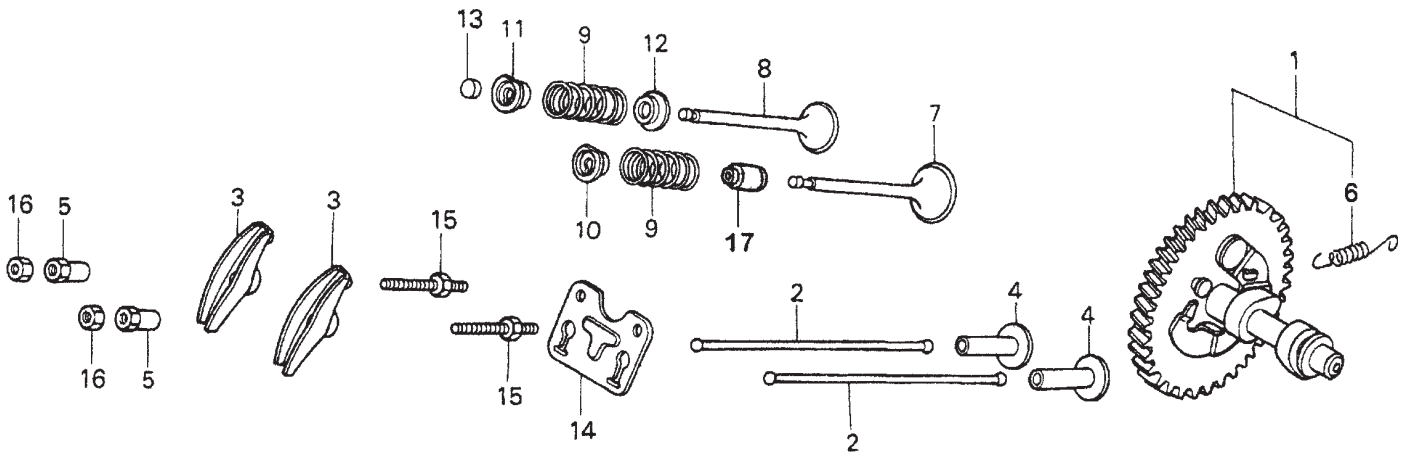

HONDA GX390K1QA2— CAMSHAFT ASSY.

<u>NO.</u>	<u>PART NO.</u>	<u>PART NAME</u>	<u>QTY.</u>	<u>REMARKS</u>
1	14100ZF6W01	CAMSHAFT ASSEMBLY	1	INCLUDES ITEMS W/* USE FROM ENGINE SN 2391940
1	14100ZF6305	CAMSHAFT	1	INCLUDES ITEMS W/* USE UP TO ENGINE SN 2391939
2	14410ZE3013	ROD, PUSH	2	
3	14431ZE2000	ARM, VALVE ROCKER	2	
3	14431ZE2010	ARM, VALVE ROCKER	2	
4	14441ZE2000	LIFTER, VALVE	2	
5	14451ZE1013	PIVOT, ROCKER ARM	2	
6*	14568ZE1000	SPRING, WEIGHT RETURN	1	
7	14711ZE3000	VALVE, INTAKE	1	
8	14721ZE3000	VALVE, EXHAUST	1	
9	14751ZE2003	SPRING, VALVE	2	
10	14771ZE2000	RETAINER, INTAKE VALVE SPRING	1	
11	14773ZE2000	RETAINER, EXHAUST VALVE SPRING	1	
12	14775ZE2010	SEAT, VALVE SPRING	1	
13	14781ZE2000	ROTATOR, VALVE	1	
14	14791ZE2010	PLATE, PUSH ROD GUIDE	1	
15	90012ZE0010	BOLT, PIVOT 8MM	2	
16	90206ZE1000	NUT, PIVOT ADJ.	2	
17	12209ZE8003	SEAL, VALVE STEM	1	USE FROM ENGINE SN 3065844

HONDA GX390K1QA2— PISTON ASSY.

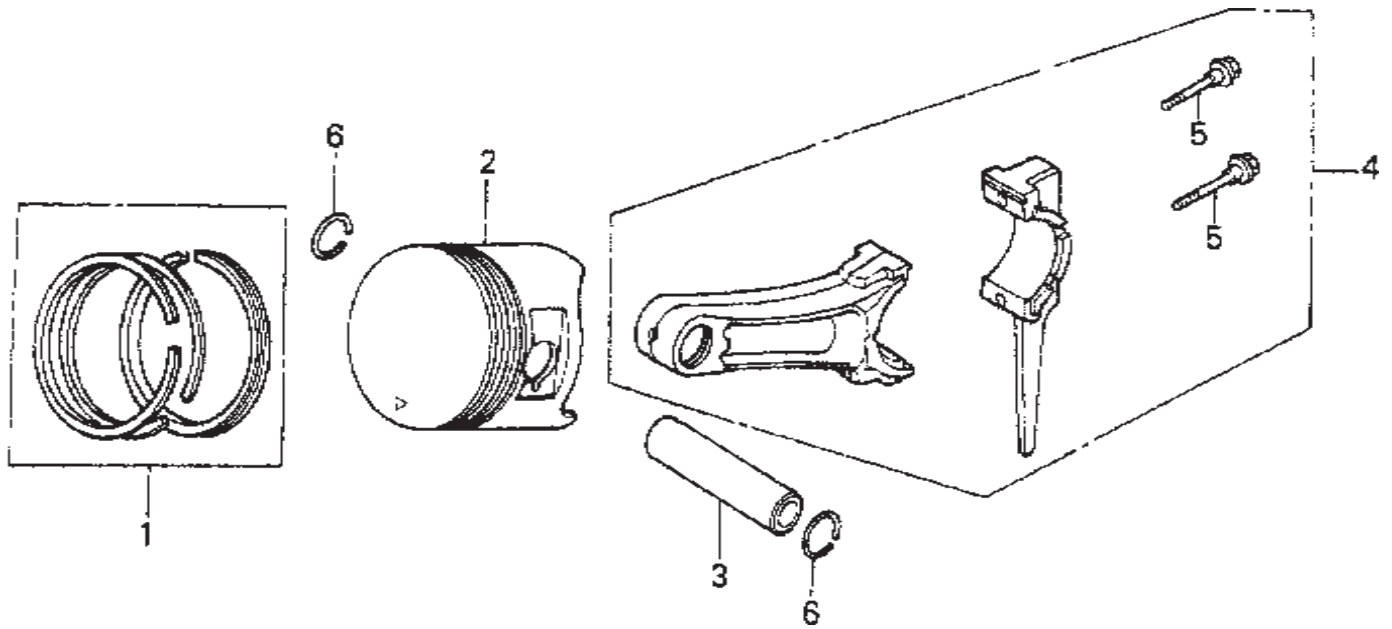

HONDA GX390K1QA2— PISTON ASSY.

<u>NO.</u>	<u>PART NO.</u>	<u>PART NAME</u>	<u>QTY.</u>	<u>REMARKS</u>
1	13010ZF6003	RING SET, PISTON (STD.)	1	
1	13011ZF6003	RING SET, PISTON (OS 0.25), OPT.	1	
1	13012ZF6003	RING SET, PISTON (OS 0.50), OPT.	1	
1	13012ZF6005	RING SET, PISTON (OS 0.50), OPT.	1	
1	13013ZF6003	RING SET, PISTON (0.75) NIPPON, OPT.	1	
2	13101ZF6W00	PISTON (STANDARD)	1	
2	13102ZF6W00	PISTON (OS 0.25), OPTIONAL	1	
2	13103ZF6W00	PISTON (OS 0.50), OPTIONAL	1	
2	13104ZF6W00	PISTON (0.75), OPTIONAL	1	
3	13111ZF6W00	PIN, PISTON	1	
4	13200ZE3010	ROD ASSEMBLY, CONNECTING (STD.)	1	INCLUDES ITEMS W/* USE UP TO ENGINE SN 3177434
4	13200ZE3020	ROD ASSEMBLY, CONNECTING (STD.)	1	INCLUDES ITEMS W/* USE FROM SN 3177435
4	13200ZE3315	ROD ASSY., CONNECTING (US 0.25), OPT. .	1	INCLUDES ITEMS W/*
5*	90001ZE8000	BOLT, CONNECTING ROD	2	
6	90601ZE3000	CLIP, PISTON PIN 20MM	2	

HONDA GX390K1QA2— CRANKCASE COVER ASSY.

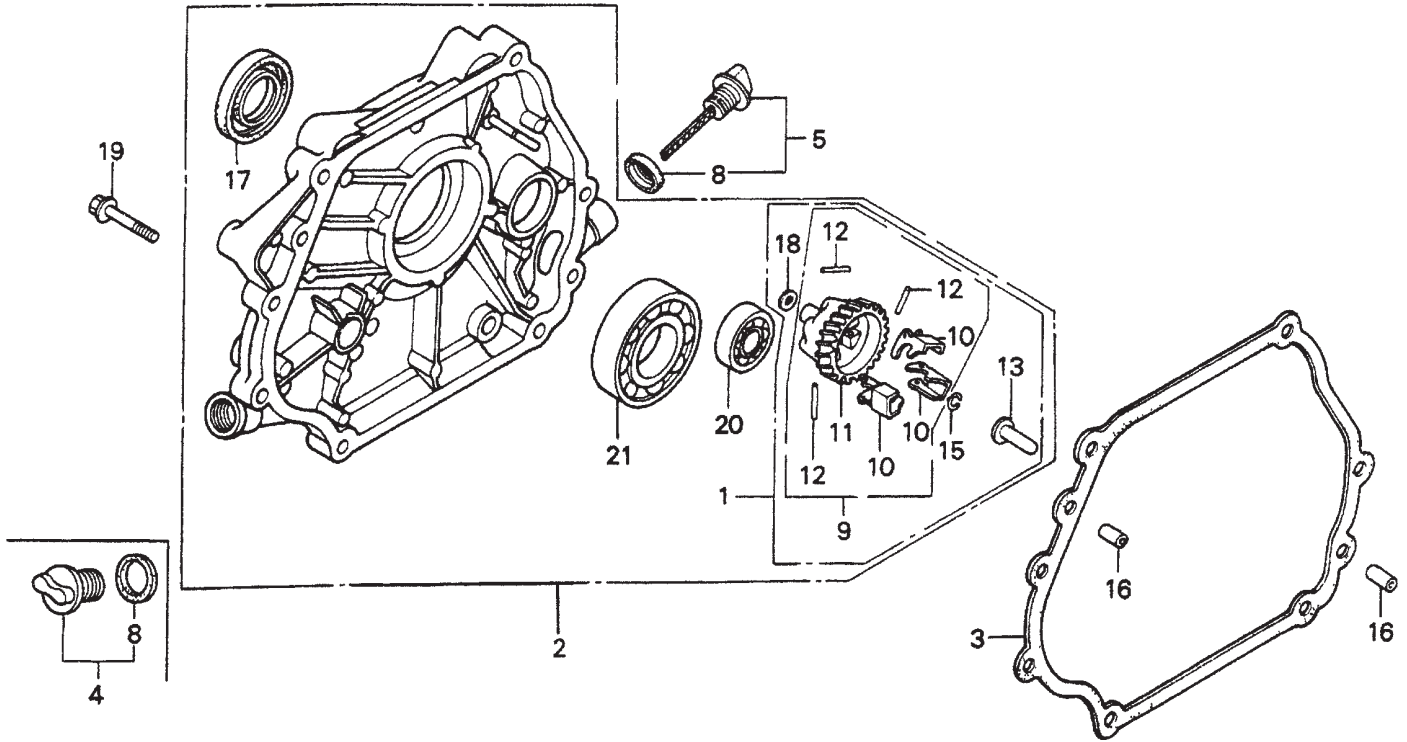

HONDA GX390K1QA2— CRANKCASE COVER ASSY.

<u>NO.</u>	<u>PART NO.</u>	<u>PART NAME</u>	<u>QTY.</u>	<u>REMARKS</u>
1*	06165ZE3000	GOVERNOR KIT (OPIONAL)	1	INCLUDES ITEMS W/#
2	11300ZE3602	COVER ASSY., CRANKCASE (Q TYPE)	1	INCLUDES ITEMS W/*
3	11381ZE3801	GASKET, CASE COVER	1	
4	15600ZG4003	CAP ASSEMBLY, OIL FILLER	1	INCLUDES ITEMS W/%
5	15600735003	CAP ASSEMBLY, OIL FILLER	1	INCLUDES ITEMS W/%
8%	15625ZE1003	GASKET, OIL FILLER CAP	2	
9*#	16510ZE3000	GOVERNOR ASSEMBLY	1	INCLUDES ITEMS W/+
10*#+	16511ZE8000	WEIGHT, GOVERNOR	3	
11*#+	16512ZE3000	HOLDER, GOVERNOR WEIGHT	1	
12*#+	16513ZE2000	PIN, GOVERNOR WEIGHT	3	
13*#+	16531ZE2000	SLIDER, GOVERNOR	1	
15*#	90602ZE1000	CLIP, GOVERNOR HOLDER	1	
16	90701HC4000	PIN, DOWEL 8X12	2	
17*	91201ZE3004	OIL SEAL 36X52X8	1	
18*#	9410106800	WASHER, PLAIN 6MM	1	
19	957010804000	BOLT, FLANGE 8X40	7	
20*	961006202000	BEARING, RADIAL BALL 6202	1	
21*	961006207000	BEARING, RADIAL BALL 6207	1	

HONDA GX390K1QA2— CRANKSHAFT ASSY.

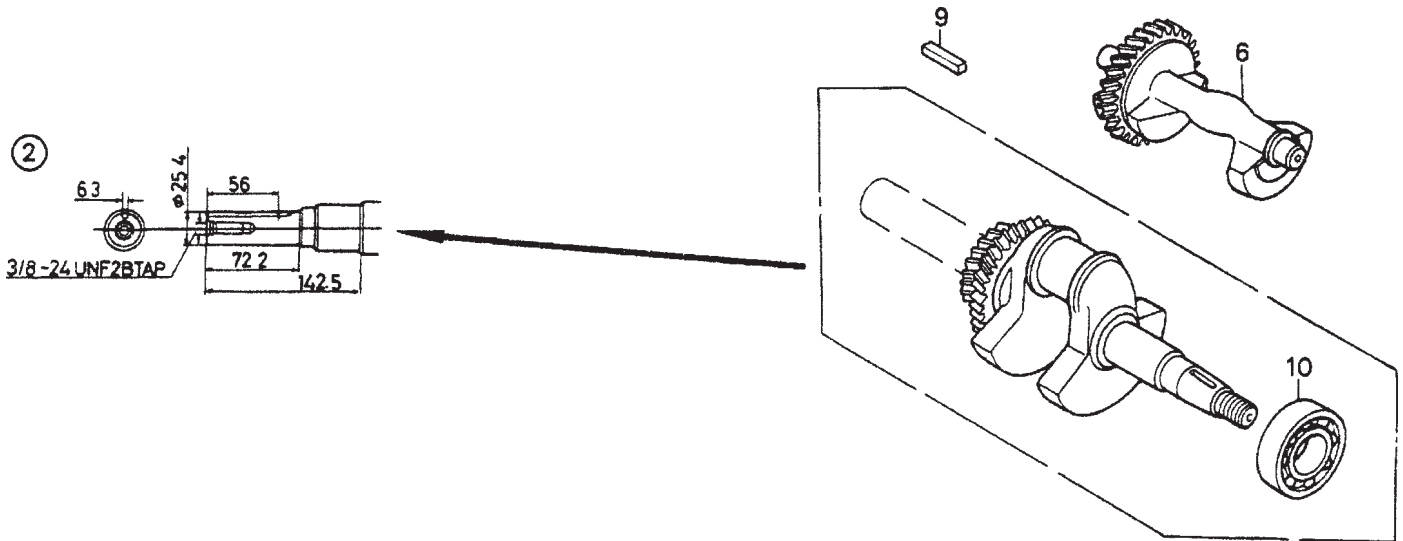

HONDA GX390K1QA2— CRANKSHAFT ASSY.

<u>NO.</u>	<u>PART NO.</u>	<u>PART NAME</u>	<u>QTY.</u>	<u>REMARKS</u>
2	13310ZF6W10	CRANKSHAFT, Q-TYPE	1	INCLUDES ITEMS W/*
6	13351ZE3010	WEIGHT, BALANCER	1	
9	90745ZE2600	KEY 6.3X6.3X43	1	
10*	91001ZF6003	BEARING, RADIAL BALL 6207S	1	

HONDA GX390K1QA2— CYLINDER BARREL ASSY.

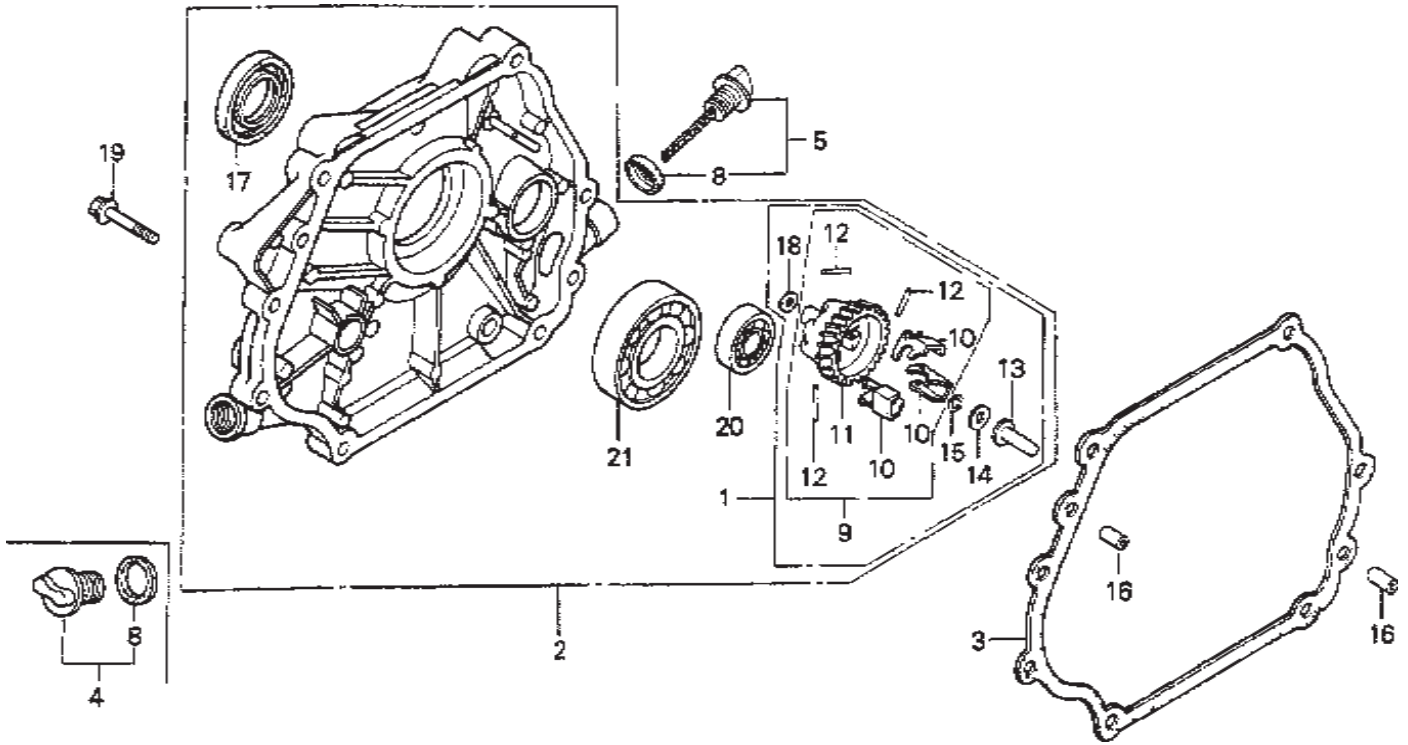

HONDA GX390K1QA2— CYLINDER BARREL ASSY.

<u>NO.</u>	<u>PART NO.</u>	<u>PART NAME</u>	<u>QTY.</u>	<u>REMARKS</u>
1	12000ZF6W12	CYLINDER ASSEMBLY, ALERT	1	INCLUDES ITEMS W/* USE UP TO ENGINE SN 3020570
1	12000ZF6W13	CYLINDER ASSEMBLY, ALERT	1	INCLUDES ITEMS W/* USE FROM ENGINE SN 3020571
2	15510ZE2033	SWITCH ASSEMBLY, OIL LEVEL	1	USE UP TO ENGINE SN 2334667
2	15510ZE2043	SWITCH ASSEMBLY, OIL LEVEL	1	USE FROM ENGINE SN 2334668
3	16541ZE3010	SHAFT, GOVERNOR ARM	1	
4	32197ZE2003	SUB-HARNESS	1	USE UP TO ENGINE SN 2334667
5	90013883000	BOLT, FLANGE 6X12 (CT200	1	USE UP TO ENGINE SN 2334667
6	90131896650	BOLT, DRAIN PLUG	2	
7	90446KE1000	WASHER 8.2X17X0.8	1	
9*	91201ZE3004	OIL SEAL 35X52X8	1	
10*	91201ZE9003	OIL SEAL 8X14X5	1	
10*	91203952771	OIL SEAL 8X14X5	1	
11	91353671003	O- RING 13.5X1.5 (ARAI)	1	
12	9405010000	NUT, FLANGE 10MM	1	
13	9410912000	WASHER, DRAIN PLUG 12MM	2	
14	9425110000	PIN,LOCK 10MM	1	
15	957010601200	BOLT, FLANGE 6X12	2	
16*	961006202000	BEARING, RADIAL BALL 6202	1	
17	90013883000	BOLT, FLANGE 6X12 (CT200)	1	USE FROM ENGINE SN 2468555
18	3415ZH7003	ALERT UNIT, OIL	1	USE FROM ENGINE SN 2468555

HONDA GX390K1QA2— CYLINDER HEAD ASSY.

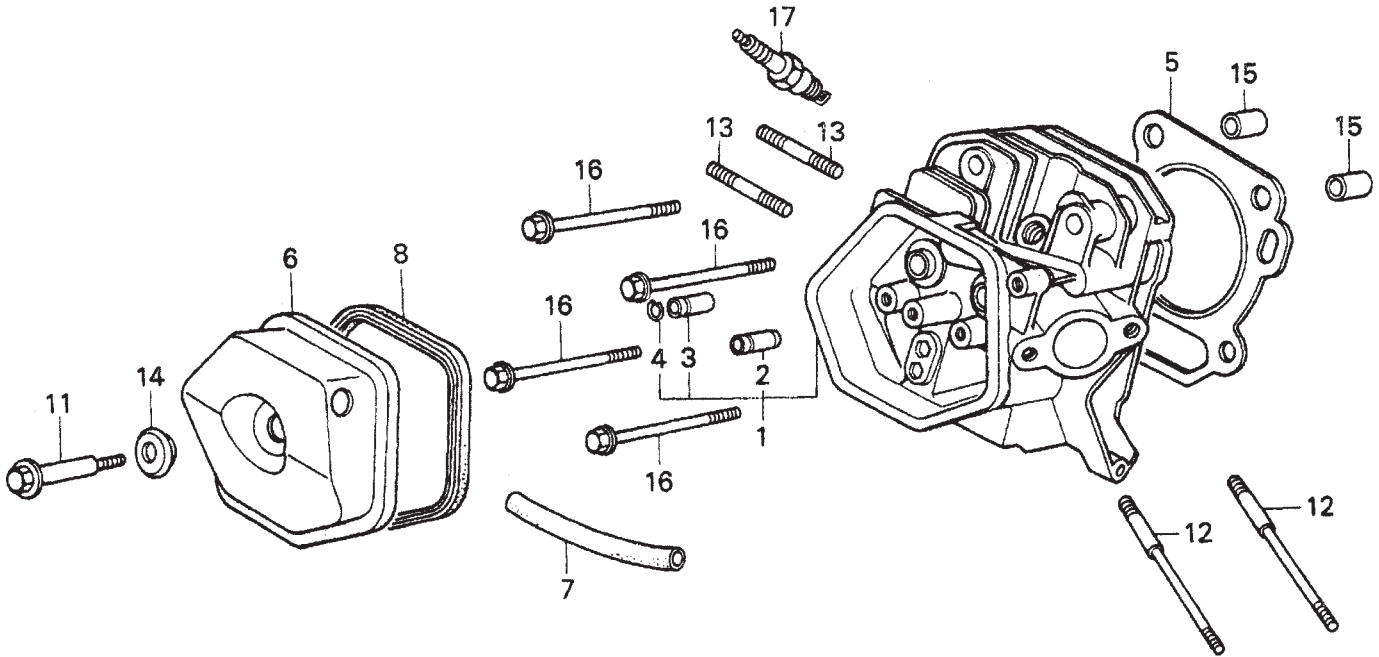

HONDA GX390K1QA2— CYLINDER HEAD ASSY.

<u>NO.</u>	<u>PART NO.</u>	<u>PART NAME</u>	<u>QTY.</u>	<u>REMARKS</u>
1	12200ZF6W01	CYLINDER HEAD	1	INCLUDES ITEMS W/*
2*	12204ZE2306	GUIDE, VALVE OS (OPTIONAL)	1	
3*	12205ZE2305	GUIDE, EX. VALVE OS (OPTIONAL)	1	
4*	12216ZE2300	CLIP, VALVE GUIDE	1	
5	12251ZF6W00	GASKET, CYLINDER HEAD	1	
6-1	12310ZE2020	COVER, HEAD	1	USE FROM ENGINE SN 2378737
6-2	12310ZE3791	COVER, HEAD	1	USE UP TO ENGINE SN 2378736
7-1	12315ZE3840	TUBE, BREATHER	1	USE FROM ENGINE SN 2368042
7-2	950051100130M	BULK HOSE, VACUUM (11X1000) (11X105) ...	1	USE UP TO ENGINE SN 2368041
8	12391ZE2020	GASKET, CYLINDER HEAD COVER	1	
11	90014ZE2000	BOLT, HEAD COVER	1	
12	90042ZE8000	BOLT, STUD 8X131.5	2	
13-1	90047ZE2000	BOLT, STUD 8X47	2	USE UP TO ENGINE SN 2638033
13-2	92900080320E	BOLT 2, STUD 8X32	2	USE FROM ENGINE SN 2638034
14	90441ZE2010	WASHER, HEAD COVER	1	
15	9430112200	PIN A, DOWEL 12X20	2	
16-1	957011008000	BOLT, FLANGE 10X80	4	
16-2	957251008000	BOLT, FLANGE 10X80	4	
17-1	9807955846	SPARK PLUG BPR5ES (NGK), OPT.	1	
17-2	9807955855	SPARK PLUG W16EPR-U (DENSO), OPT.	1	
17-3	9807956846	SPARK PLUG BPR6ES (NGK)	1	
17-4	9807956855	SPARK PLUG W20EPR-U (DENSO)	1	

HONDA GX390K1QA2— FAN COVER ASSY.

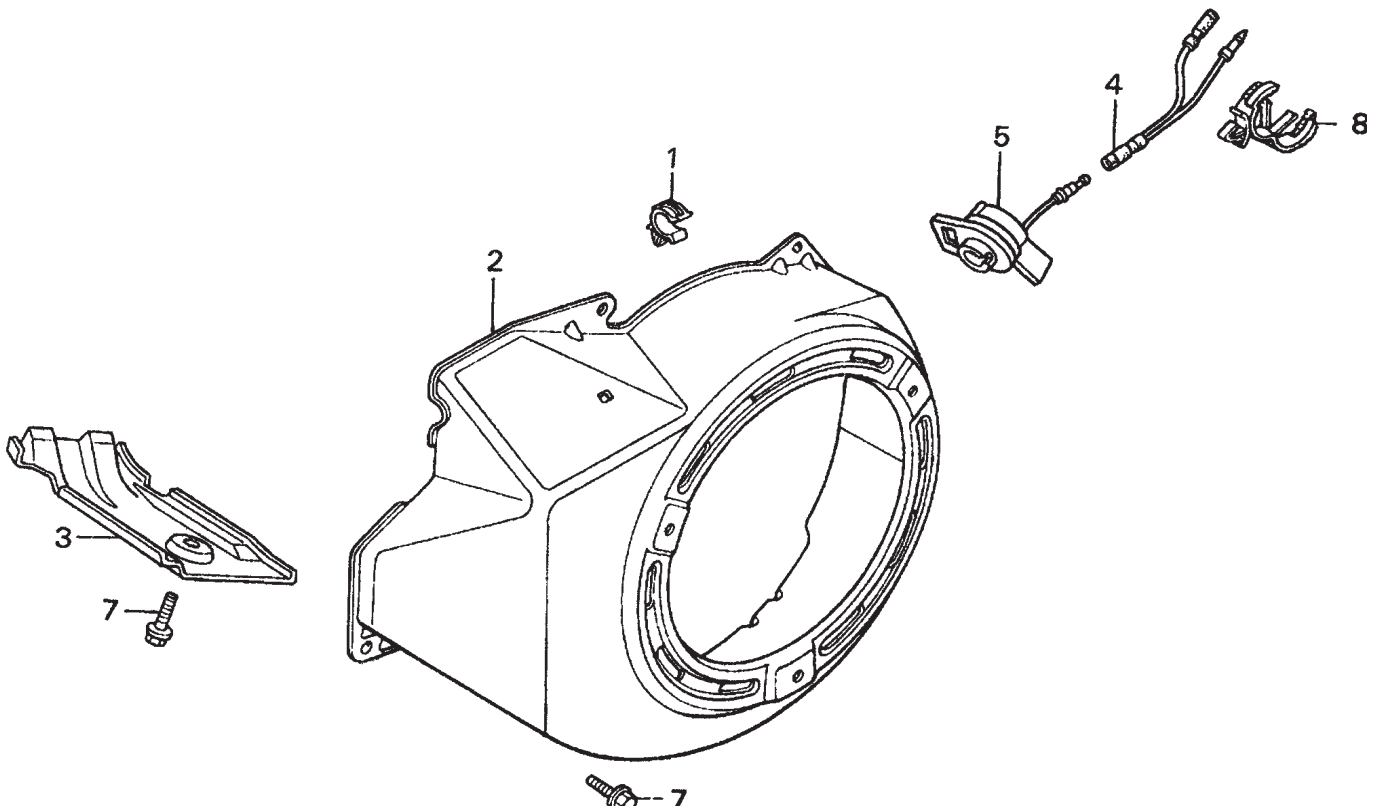

HONDA GX390K1QA2— FAN COVER ASSY.

<u>NO.</u>	<u>PART NO.</u>	<u>PART NAME</u>	<u>QTY.</u>	<u>REMARKS</u>
1	16731ZE2003	CLIP, TUBE	1	
2	19610ZE3010ZB	COVER, FAN *NH1*, BLACK	1	
3	19631ZE3W00	SHROUD	1	
4	32197ZH8003	SUB-HARNESS	1 USE UP TO ENGINE SN 2334667
5	36100ZE1015	SWITCH ASSEMBLY, ENGINE STOP	1 USE UP TO ENGINE SN 2334667
5	36100ZH7003	SWITCH ASSEMBLY, ENGINE STOP	1 USE FROM ENGINE SN 2334668
7	90013883000	BOLT, FLANGE 6X12 (CT200)	6	
9	90684ZA0601	CLIP, WIRE HARNESS	1	

HONDA GX390K1QA2— FLYWHEEL ASSY.

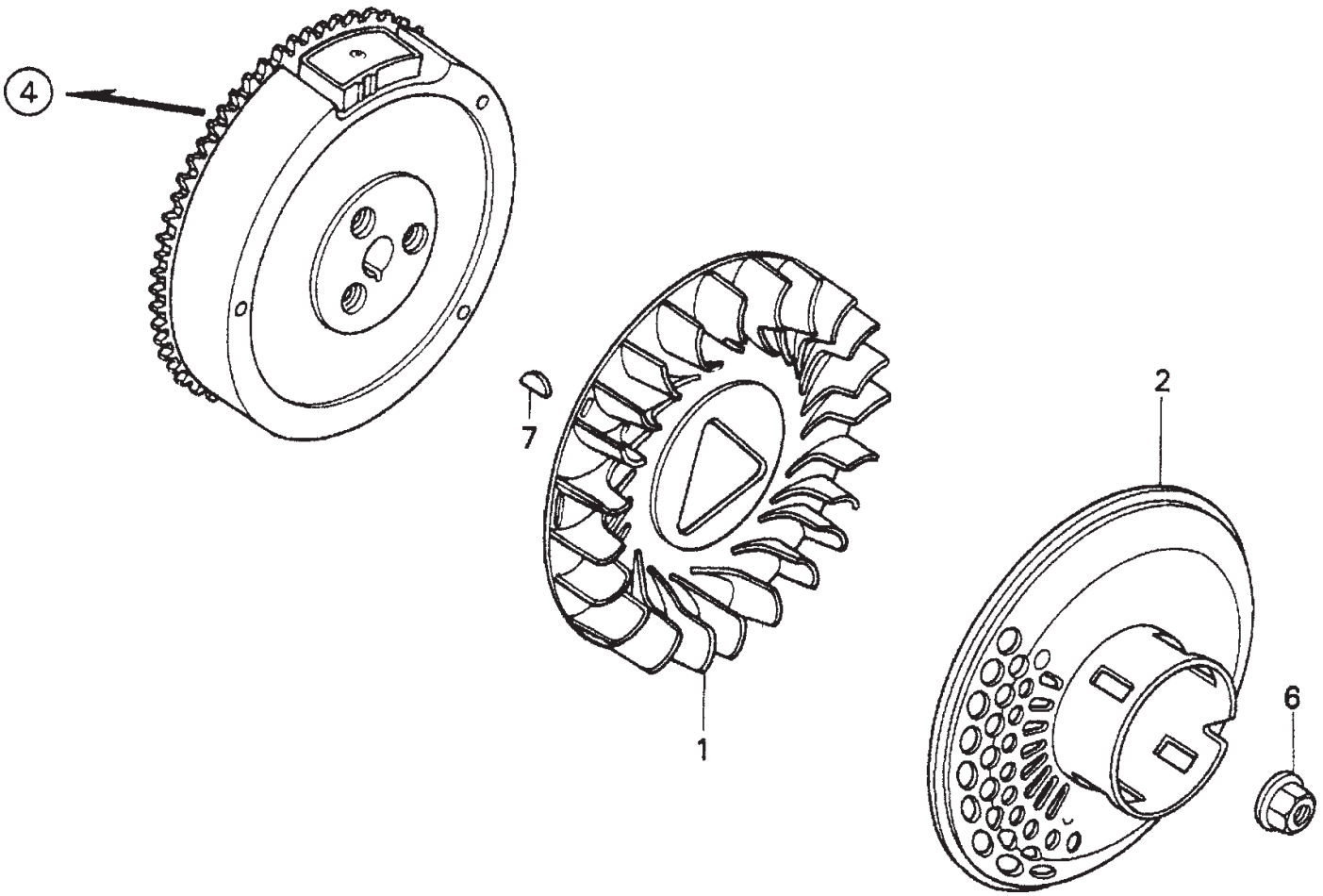

HONDA GX390K1QA2— FLYWHEEL ASSY.

<u>NO.</u>	<u>PART NO.</u>	<u>PART NAME</u>	<u>QTY.</u>	<u>REMARKS</u>
1	19511ZE3000	FAN, COOLING	1	
2	28450ZE3W11	PULLEY, STARTER (SCREEN GRID)	1	
4	31100ZE3701	FLYWHEEL	1	
6-1	90201ZE3V00	NUT, SPECIAL 16MM (1)	1 USE FROM ENGINE SN 2263435
6-2	90201ZE3790	NUT, SPECIAL 16MM	1 USE UP TO ENGINE SN 2263434
7	90741ZE2000	KEY, SPECIAL WOODRUFF 25X18	1	

HONDA GX390K1QA2— FUEL TANK ASSY.

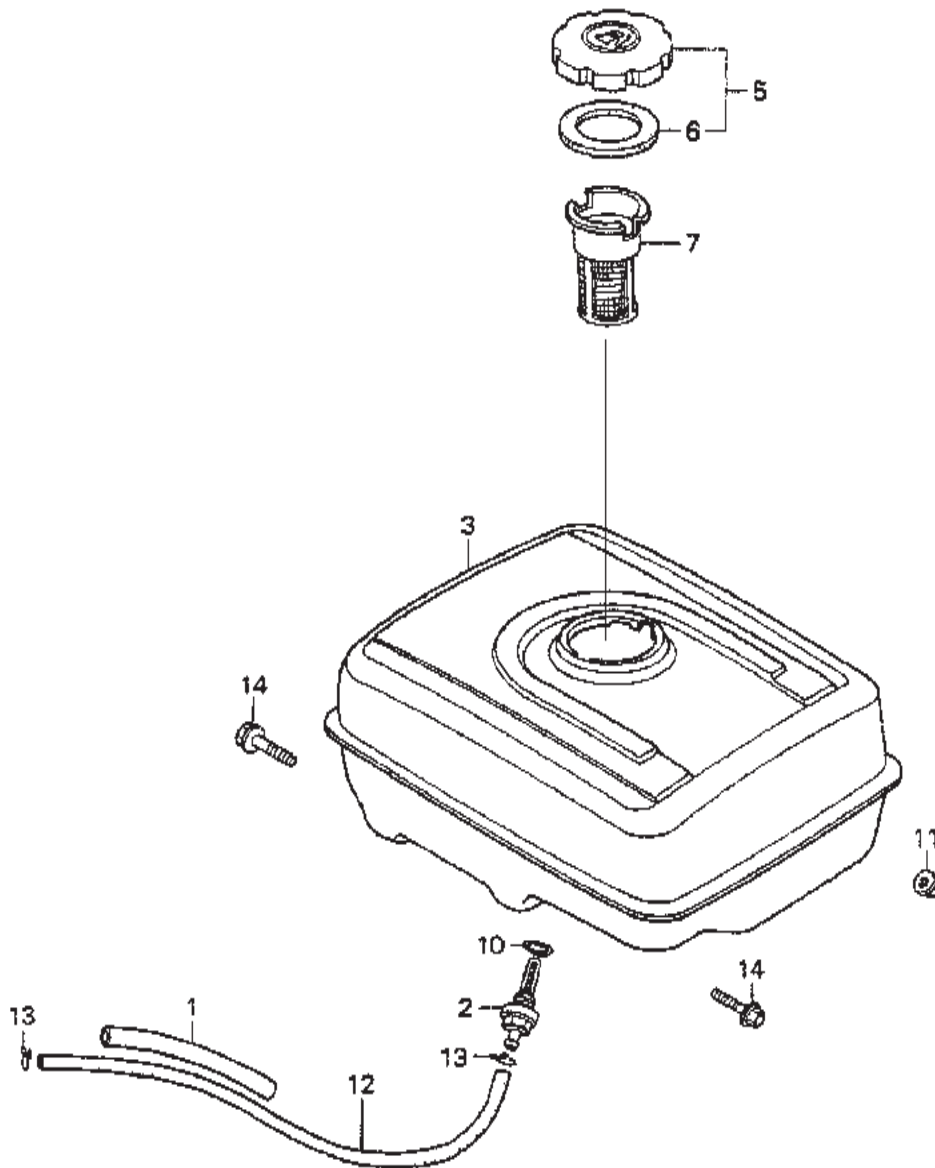

HONDA GX390K1QA2— FUEL TANK ASSY.

<u>NO.</u>	<u>PART NO.</u>	<u>PART NAME</u>	<u>QTY.</u>	<u>REMARKS</u>
1	16854ZH8000	RUBBER, SUPPORTER 107 MM	1	
2	16955ZE1000	JOINT, FUEL TANK	1	
3	17510ZE3010ZB	TANK, FUEL *NH1* (BLACK)	1	
5	17620ZH7023	CAP, FUEL FILLER.....	1	INCLUDES ITEM W/*
6*	17631ZH7003	GASKET, FUEL FILLER CAP	1	
7	17672ZE2W01	FILTER, FUEL	1	
10	91353671003	O- RING 13.5X1.5 (ARAI)	1	
11	9405008000	NUT, FLANGE 8MM	2	
12	950014500360M	BULK HOSE, FUEL (4.5X3000) (4.5X235)	1	
13	9500202080	CLIP, TUBE B8	2	
14	957010802500	BOLT, FLANGE 8X25	2	

HONDA GX390K1QA2— IGNITION COIL ASSY.

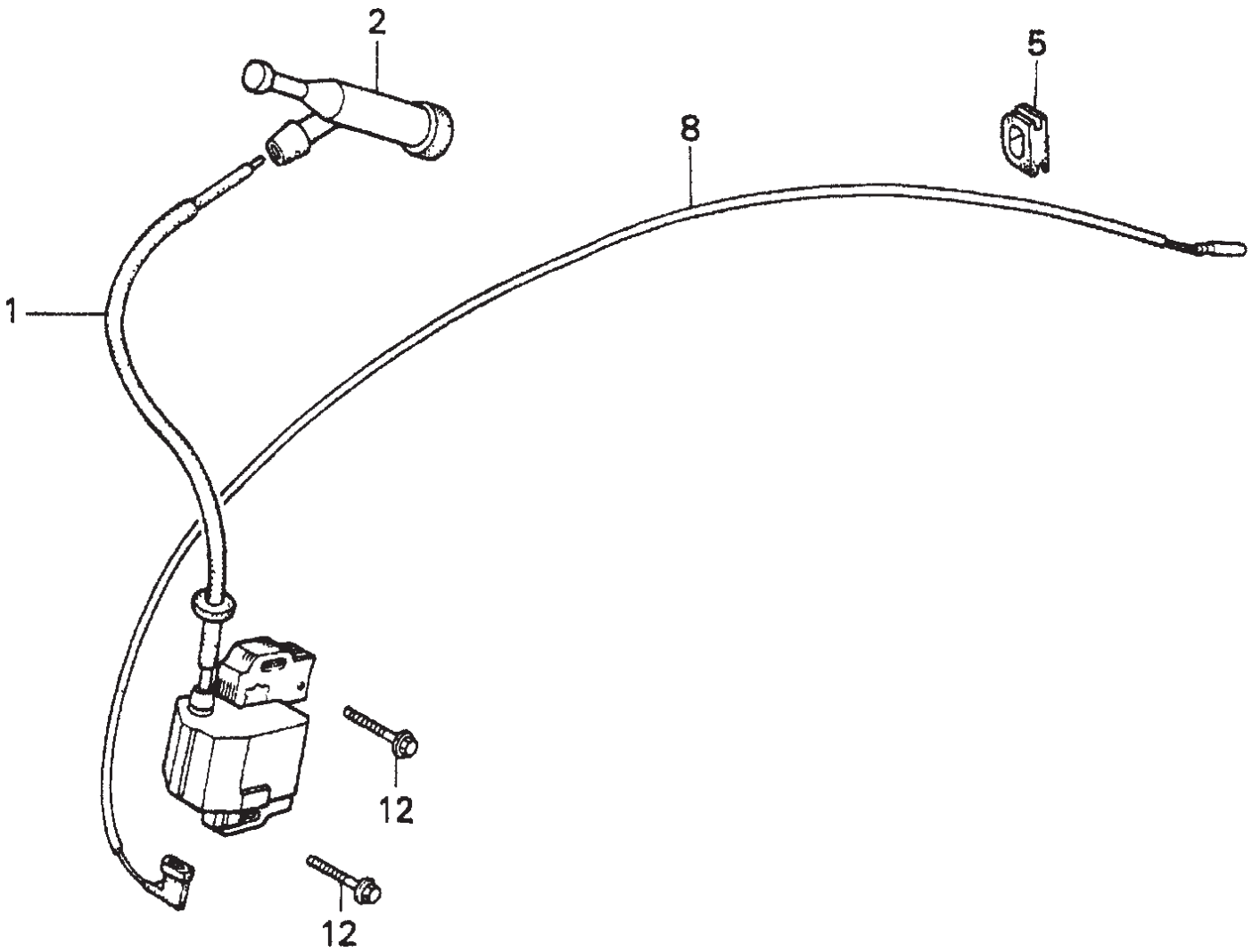

HONDA GX390K1QA2— IGNITION COIL ASSY.

<u>NO.</u>	<u>PART NO.</u>	<u>PART NAME</u>	<u>QTY.</u>	<u>REMARKS</u>
1	30500ZE2023	COIL ASSEMBLY, IGNITION	1	USE UP TO ENGINE SN 2108412
1	30500ZF6W01	COIL ASSEMBLY, IGNITION	1	USE FROM ENGINE SN 2108413
2	30700ZE1013	CAP ASSEMBLY, NOISE SUPPRESSOR	1	
5	31512ZE2000	GROMMET, WIRE	1	
8	36101ZE2701	WIRE, STOP SWITCH 430MM	1	
12	90015883000	BOLT, FLANGE 6X28	2	

HONDA GX390K1QA2— CARBURETOR ASSY.

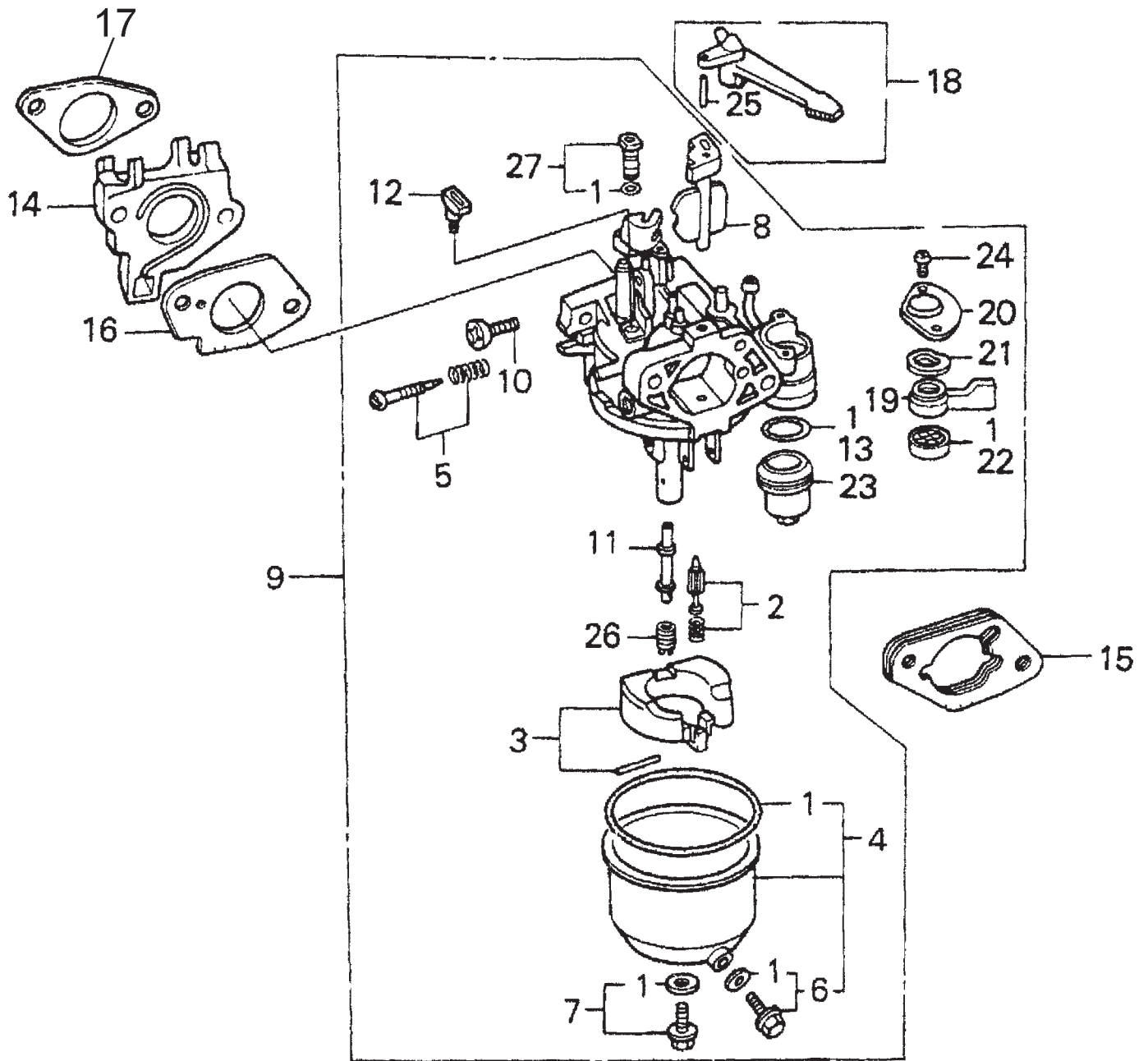

HONDA GX390K1QA2— CARBURETOR ASSY.

<u>NO.</u>	<u>PART NO.</u>	<u>PART NAME</u>	<u>QTY.</u>	<u>REMARKS</u>
1#%	16010ZE2812	GASKET SET	1	
2*	16011ZA0931	VALVE SET, FLOAT	1	
3*	16013ZA0931	FLOAT SET	1	
4*	16015ZE2005	CHAMBER SET, FLOAT	1	INCLUDES ITEMS W/% USE UP TO ENGINE SN BE85B A
4*	16015ZE8005	CHAMBER SET, FLOAT	1	INCLUDES ITEMS W/% USE FROM ENGINE SN BE85B B
5*	16016ZH7W01	SCREW SET	1	
6*%	16024ZE1811	SCREW SET, DRAIN	1	INCLUDES ITEMS W/#
7*	16028ZE0005	SCREW SET B	1	INCLUDES ITEMS W/#
8*	16044ZE3W20	CHOKE SET	1	
9	16100ZF6V01	CARBURETOR ASSEMBLY, BE85B B	1	INCLUDES ITEMS W/* USE UP TO ENGINE SN 2255423
10*	16124ZE0005	SCREW, THROTTLE STOP	1	
11*	16166ZF6V00	NOZZLE, MAIN	1	
12*	16172ZE3W10	COLLAR, SET	1	
13*	16173001004	GASKET, FUEL STRAINER CUP	1	
14	16211ZF6000	INSULATOR, CARBURETOR	1	
15	16220ZA0702	SPACER, CARBURETOR	1	
16	16221ZF6800	GASKET, CARBURETOR	1	
17	16223ZE3W00	GASKET, INSULATOR	1	
18	16610ZE1000	LEVER, CHOKE (STANDARD)	1	INCLUDES ITEMS W/+
19*	16953ZE1406	LEVER, VALVE	1	USE UP TO ENGINE SN BE85B A
19*	16953ZE1812	LEVER, VALVE	1	USE FROM ENIGNE SN BE85B B
20*	16954ZE1811	PLATE, LEVER SETTING	1	
20*	16954ZE1812	PLATE, LEVER SETTING	1	
21*	16956ZE1811	SPRING, VALVE LEVER	1	
22*	16957ZE1812	GASKET, VALVE	1	
23*	16967ZE0811	CUP, FUEL STRAINER	1	
24*	93500030060H	SCREW, PAN 3X6	2	USE FROM ENGINE SN BE85C B
24*	93500030080G	SCREW, PAN 3X8	2	USE UP TO ENGINE SN BE85C A
25+	9430520122	PIN, SPRING 2X12	1	
26	99101ZH80880	JET, MAIN #88 (OPTIONAL)	1	
26	99101ZH80900	JET, MAIN #90 (OPTIONAL)	1	
26*	99101ZH80920	JET, MAIN #92	1	
27*	99204ZA00450	JET SET, PILOT #45	1	INCLUDES ITEMS W/#

HONDA GX390K1QA2— MUFFLER ASSY.

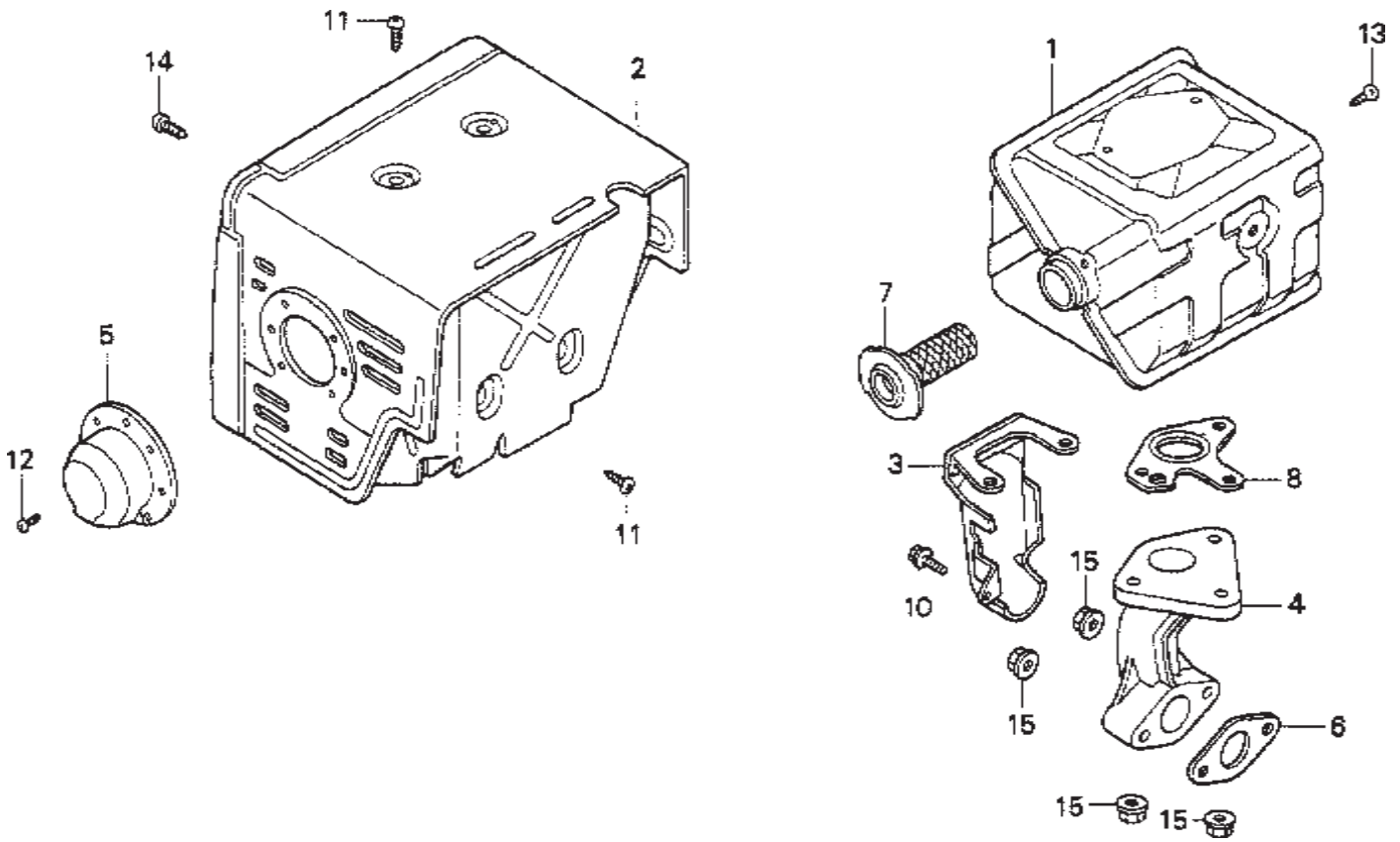

HONDA GX390K1QA2— MUFFLER ASSY.

<u>NO.</u>	<u>PART NO.</u>	<u>PART NAME</u>	<u>QTY.</u>	<u>REMARKS</u>
1	18310ZE2W51	MUFFLER 100DB (SILENT)	1	USE UP TO ENGINE SN 2638033
1	18310ZE2W61	MUFFLER 100DB	1	USE FROM ENGINE SN 2638034
2	18320ZE2W61	PROTECTOR, MUFFLER	1	
3	18323ZE3W40	PROTECTOR, EXHAUST PIPE	1	
4	18330ZE2W00	PIPE, EXHAUST	1	
5	18331ZE3810	CAP, MUFFLER	1	
6	18333ZK6Y00	GASKET, EXHAUST PIPE	1	USE UP TO ENGINE SN 2275744
6	18333ZF6W01	GASKET, EXHAUST PIPE	1	USE FROM ENGINE SN 2638034
7	18355ZE2W00	ARRESTER, SPARK	1	
8	18381ZE2W10	GASKET, MUFFLER (ARRESTER)	1	
10	90013883000	BOLT, FLANGE 6X12 (CT200)	1	
11	90050ZE1000	SCREW, TAPPING 5X8	4	
12	90055ZE1000	SCREW, TAPPING 4X6	3	
13	90055ZE1000	SCREW, TAPPING 4X6	1	
14	90006ZE2000	SCREW, TAPPING 6X10	1	
15	9405008000	NUT, FLANGE 8MM	5	

HONDA GX390K1QA2— RECOIL STARTER ASSY.

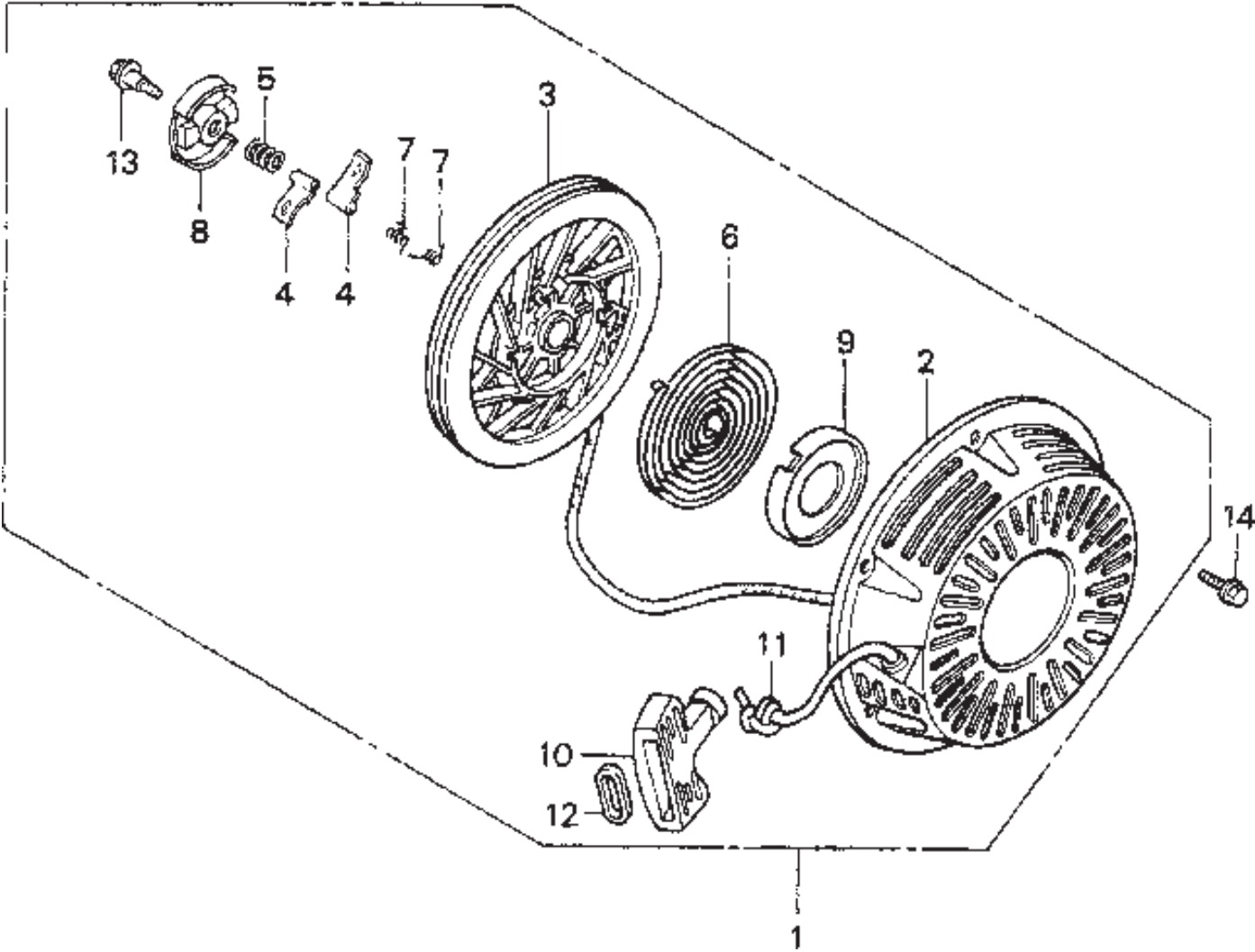

HONDA GX390K1QA2— RECOIL STARTER ASSY.

<u>NO.</u>	<u>PART NO.</u>	<u>PART NAME</u>	<u>QTY.</u>	<u>REMARKS</u>
1	28400ZE3W01ZB	STARTER ASSY., RECOIL *NH1*, BLACK.....	1	INCLUDES ITEMS W/*
2*	28410ZE3W01ZB	CASE, RECOIL STARTER *NH1*, BLACK	1	
3*	28421ZE3W01	PULLEY, RECOIL STARTER	1	
4*	28422ZE2W01	RATCHET, STARTER	2	
5*	28441ZE2W01	SPRING, FRICTION	1	
6*	28442ZE2W01	SPRING, STARTER RETURN	1	
7*	28443ZE2W01	SPRING, RATCHET	2	
8*	28444ZE2W01	RETAINER, SPRING	1	
9*	28445ZE2W01	HOLDER, SPRING	1	
10*	28461ZE2W02	GRIP, STARTER	1	
11*	28462ZV7003	ROPE, RECOIL STARTER	1	
12*	28469ZE2W01	GRIP, REINFORCEMENT	1	USE UP TO ENGINE SN 2584635
13*	90004ZE2W01	SCREW, CENTER	1	
14	90008ZE2003	BOLT, FLANGE 6X10	3	

NO ART WORK

HONDA GX390K1QA2— CONTROL ASSY.

<u>NO.</u>	<u>PART NO.</u>	<u>PART NAME</u>	<u>QTY.</u>	<u>REMARKS</u>
2	16551ZE3000	ARM, GOVERNOR	1	
3	16555ZE3000	ROD, GOVERNOR	1	
4	16561ZE3000	SPRING, GOVERNOR	1	
5	16562ZE3000	SPRING, THROTTLE RETURN	1	
8	16570ZE3W20	CONTROL ASSEMBLY, REMOTE	1	
11	16571ZE3W00	LEVER, CONTROL	1	
12	16574ZE1000	SPRING, LEVER	1	
13	1675ZE2W00	WASHER, CONTROL LEVER	1	
14	16576891000	HOLDER, CABLE	1	
15	16578ZE1000	SPACER, CONTROL LEVER	1	
1?	16581ZE3W00	BASE, CONTROL	1	
19	16584883300	SPRING, CONTROL ADJUSTING	1	
20	16592883310	SPRING, CABLE RETURN	1	
22	90013883000	BOLT, FLANGE (6X12) (CT200)	2	
23	90015ZE5010	BOLT, GOVERNOR ARM	1	
24	90114SA0000	NUT, SELF-LOCK (6MM)	1	
27	93500050320A	SCREW, PAN (5X32)	1	
30	93500050160A	SCREW, PAN (5X16)	1	
31	9405006000	NUT, FLANGE (6MM)	1	

NO ART WORK

HONDA GX390K1QA2— GASKET KIT ASSY.

<u>NO.</u>	<u>PART NO.</u>	<u>PART NAME</u>	<u>QTY.</u>	<u>REMARKS</u>
1	11381ZE3800	GASKET, CASE COVER	1	
3	12251ZF6W00	GASKET, CYLINDER HEAD	1	
4	12391ZE2020	GASKET, CYLINDER HEAD COVER	1	
5	16221ZF6800	GASKET, CARBURETOR	1	
6	16223ZE3W00	GASKET, INSULATOR	1	
7	18333ZE3800	GASKET, EXHAUST PIPE	1	
7	18333ZF6W01	GASKET, EXHAUST PIPE	1	
8	18381ZE2W10	GASKET, MUFFLER (ARRESTER)	1	
9	06111ZF6407	GASKET KIT	1	

HONDA GX390K1QA2— LABELS ASSY.

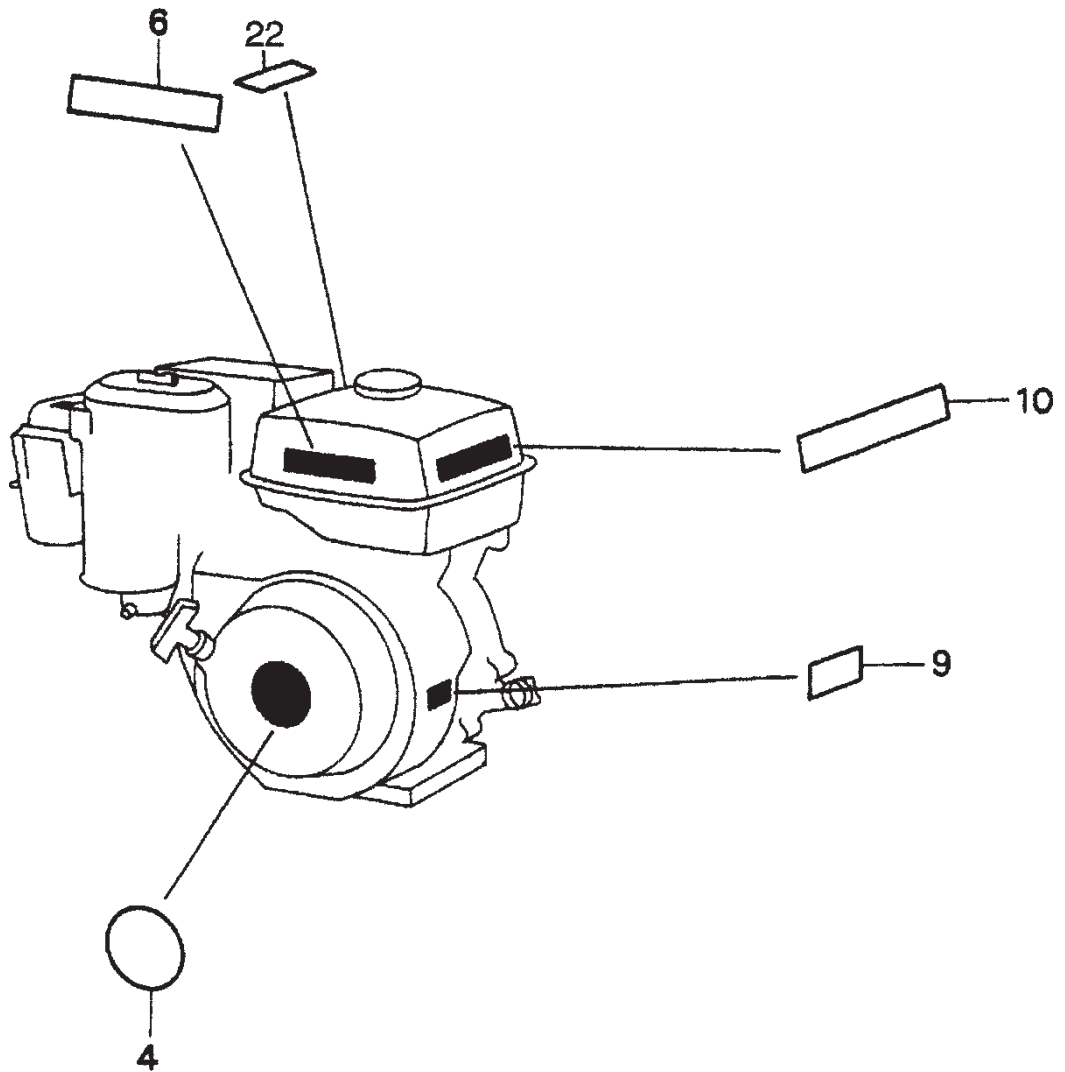

HONDA GX390K1QA2— LABELS ASSY.

<u>NO.</u>	<u>PART NO.</u>	<u>PART NAME</u>	<u>QTY.</u>	<u>REMARKS</u>
?	87521ZF6W01	EMBLEM	1	
6	87522ZH9000	LABEL, CAUTION	1	
9	87530ZF6W10	LABEL, SPECIFICATION	1 USE UP TO ENGINE SN 2172909
10	87532ZH8810	MARK, OIL ALERT (E)	1	
16	89218ZE1000	WRENCH, SPARK PLUG	1	
22	87576ZH7W00	LABEL, FUEL CAUTION	1	

TERMS AND CONDITIONS OF SALE — PARTS

PAYMENT TERMS

Terms of payment for parts are net 30 days.

FREIGHT POLICY

All parts orders will be shipped collect or prepaid with the charges added to the invoice. All shipments are F.O.B. point of origin. Multiquip's responsibility ceases when a signed manifest has been obtained from the carrier, and any claim for shortage or damage must be settled between the consignee and the carrier.

MINIMUM ORDER

The minimum charge for orders from Multiquip is \$15.00 net. Customers will be asked for instructions regarding handling of orders not meeting this requirement.

RETURNED GOODS POLICY

Return shipments will be accepted and credit will be allowed, subject to the following provisions:

1. A Returned Material Authorization must be approved by Multiquip prior to shipment.
2. To obtain a Return Material Authorization, a list must be provided to Multiquip Parts Sales that defines item numbers, quantities, and descriptions of the items to be returned.
 - a. The parts numbers and descriptions must match the current parts price list.
 - b. The list must be typed or computer generated.
 - c. The list must state the reason(s) for the return.
 - d. The list must reference the sales order(s) or invoice(s) under which the items were originally purchased.
 - e. The list must include the name and phone number of the person requesting the RMA.
3. A copy of the Return Material Authorization must accompany the return shipment.
4. Freight is at the sender's expense. All parts must be returned freight prepaid to Multiquip's designated receiving point.

5. Parts must be in new and resalable condition, in the original Multiquip package (if any), and with Multiquip part numbers clearly marked.
6. The following items are not returnable:
 - a. Obsolete parts. (If an item is in the price book and shows as being replaced by another item, it is obsolete.)
 - b. Any parts with a limited shelf life (such as gaskets, seals, "O" rings, and other rubber parts) that were purchased more than six months prior to the return date.
 - c. Any line item with an extended dealer net price of less than \$5.00.
 - d. Special order items.
 - e. Electrical components.
 - f. Paint, chemicals, and lubricants.
 - g. Decals and paper products.
 - h. Items purchased in kits.
7. The sender will be notified of any material received that is not acceptable.
8. Such material will be held for five working days from notification, pending instructions. If a reply is not received within five days, the material will be returned to the sender at his expense.
9. Credit on returned parts will be issued at dealer net price at time of the original purchase, less a 15% restocking charge.
10. In cases where an item is accepted, for which the original purchase document can not be determined, the price will be based on the list price that was effective twelve months prior to the RMA date.
11. Credit issued will be applied to future purchases only.

PRICING AND REBATES

Prices are subject to change without prior notice. Price changes are effective on a specific date and all orders received on or after that date will be billed at the revised price. Rebates for price declines and added charges for price increases will not be made for stock on hand at the time of any price change.

Multiquip reserves the right to quote and sell direct to Government agencies, and to Original Equipment Manufacturer accounts who use our products as integral parts of their own products.

SPECIAL EXPEDITING SERVICE

A \$35.00 surcharge will be added to the invoice for special handling including bus shipments, insured parcel post or in cases where Multiquip must personally deliver the parts to the carrier.

LIMITATIONS OF SELLER'S LIABILITY

Multiquip shall not be liable hereunder for damages in excess of the purchase price of the item with respect to which damages are claimed, and in no event shall Multiquip be liable for loss of profit or good will or for any other special, consequential or incidental damages.

LIMITATION OF WARRANTIES

No warranties, express or implied, are made in connection with the sale of parts or trade accessories nor as to any engine not manufactured by Multiquip. Such warranties made in connection with the sale of new, complete units are made exclusively by a statement of warranty packaged with such units, and Multiquip neither assumes nor authorizes any person to assume for it any other obligation or liability whatever in connection with the sale of its products. Apart from such written statement of warranty, there are no warranties, express, implied or statutory, which extend beyond the description of the products on the face hereof.

Effective: February 22, 2006

OPERATION AND PARTS MANUAL

HERE'S HOW TO GET HELP

PLEASE HAVE THE MODEL AND SERIAL
NUMBER ON-HAND WHEN CALLING

UNITED STATES

Multiquip Corporate Office

18910 Wilmington Ave. Tel. (800) 421-1244
Carson, CA 90746 Fax (800) 537-3927
Contact: mq@multiquip.com

Mayco Parts

800-306-2926 Fax: 800-672-7877
310-537-3700 Fax: 310-637-3284

Service Department

800-421-1244 Fax: 310-537-4259
310-537-3700

MQ Parts Department

800-427-1244 Fax: 800-672-7877
310-537-3700 Fax: 310-637-3284

Warranty Department

800-421-1244, Ext. 279 Fax: 310-537-1173
310-537-3700, Ext. 279

Technical Assistance

800-478-1244 Fax: 310-631-5032

MEXICO

MQ Cipsa

Carr. Fed. Mexico-Puebla KM 126.5 Tel: (52) 222-225-9900
Momoxpan, Cholula, Puebla 72760 Mexico Fax: (52) 222-285-0420
Contact: pmastretta@cipsa.com.mx

CANADA

Multiquip

4110 Industriel Boul. Tel: (450) 625-2244
Laval, Quebec, Canada H7L 6V3 Tel: (877) 963-4411
Contact: jmartin@multiquip.com Fax: (450) 625-8664

UNITED KINGDOM

Multiquip (UK) Limited Head Office

Unit 2, Northpoint Industrial Estate, Tel: 0161 339 2223
Global Lane, Fax: 0161 339 3226
Dukinfield, Cheshire SK16 4UJ
Contact: sales@multiquip.co.uk

© COPYRIGHT 2010, MULTIQUIP INC.

Multiquip Inc, the MQ logo and the Whiteman logo are registered trademarks of Multiquip Inc. and may not be used, reproduced, or altered without written permission. All other trademarks are the property of their respective owners and used with permission.

This manual **MUST** accompany the equipment at all times. This manual is considered a permanent part of the equipment and should remain with the unit if resold.

The information and specifications included in this publication were in effect at the time of approval for printing. Illustrations, descriptions, references and technical data contained in this manual are for guidance only and may not be considered as binding. Multiquip Inc. reserves the right to discontinue or change specifications, design or the information published in this publication at any time without notice and without incurring any obligations.

Your Local Dealer is:

